



Rolling Bearings

Technical principles and product data for
the design of rolling bearing arrangements

SCHAEFFLER



Although we have prepared and checked all of the data in this catalogue with a great deal of care, we cannot guarantee 100% accuracy. We reserve the right to make corrections.

This catalogue is intended for general information only, in order to make reference to our product range. In particular, it neither serves as technical advice nor as guidance, and the illustrations and descriptions contained herein should not be regarded as assured product characteristics.

The continuous availability of the described products cannot be guaranteed. We also reserve the right to deliver comparable products to those described herein, where there is a phase-out or changeover of production, provided that:

- There are only negligible technical deviations from the description provided here
- The other product is, in abstract terms, at least equivalent in quality
- The change is also reasonable to you as the customer in all other respects, taking account of our interests.

 *Issuer, copyright* © Schaeffler Technologies AG & Co. KG

All rights reserved.

Reproduction, distribution and translation of this publication – in whole or in part – are only permitted with the written permission of the issuer and if the source is indicated.

June 2018. Older catalogue versions will be completely replaced by this version.

 *Print* Printed in Germany by mohn



Rolling Bearings

Technical principles and product data
for the design of rolling bearing arrangements

Contents



	Foreword	6
1	X-life	10
2	medias professional	12
3	BEARINX	14
4	Criteria for bearing selection	17

Technical principles 32

1	Load carrying capacity and life	34
2	Rigidity	54
3	Friction and increases in temperature	56
4	Speeds	64
5	Noise	69
6	Lubrication	70
7	Bearing data	97
8	Design of bearing arrangements	139
9	Sealing of bearing positions	182
10	Mounting and dismounting	191

Product range A **208**

Deep groove ball bearings	208
Angular contact ball bearings	278
Four point contact bearings	346
Self-aligning ball bearings	366
Cylindrical roller bearings	408
Tapered roller bearings	554
Barrel roller bearings	638
Spherical roller bearings	662
Toroidal roller bearings	796
Needle roller and cage assemblies	852
Drawn cup needle roller bearings	882
Needle roller bearings	910
Drawn cup roller clutches	1006
Sealing rings	1024

Product range B **1038**

Axial deep groove ball bearings	1038
Axial cylindrical roller bearings	1072
Axial needle roller bearings	1096
Axial spherical roller bearings	1114
Crossed roller bearings	1138
Super precision bearings	1172
Track rollers	1376
Radial insert ball bearings	1448
Bearing housings	1566
Fasteners and retainers	1690
Rolling elements	1748
Other products	1756
Product index	1802

Foreword

🔗 *Schaeffler provides trendsetting solutions for Industrial and Automotive applications*

🔗 *Keys to success*

Schaeffler is a leading worldwide supplier of rolling bearings, spherical plain bearings, plain bearings, linear products, accessories specific to bearings and comprehensive maintenance products and services. We have in excess of 40 000 catalogue products manufactured as standard, providing an extremely wide portfolio that gives secure coverage of applications from all 60 designated industrial market sectors.

The central factors responsible for this success are our outstanding strength in innovation, our global focus on local customer proximity, highly developed manufacturing methods, extremely high quality standards in all processes and our ability to transform specific customer requirements quickly and accurately into cost-effective solutions. Against this background of expertise, knowledge and experience together with our wide range of catalogue items, we see ourselves as a high performance, customer focussed partner.

Research and development

🔗 *Research and development as a global approach*

As a company looking to the future, we are especially active in the field of research and development. The key areas in this respect include not only research into fundamental principles, materials technology, tribology and calculation but also extensive inspection and test methods as well as activities to optimise manufacturing technology. This is oriented towards ensuring the continuous development, improvement and application of our products in the long term. We carry out research and development on a global basis. Our development centres are linked with each other worldwide and are thus in a position to exchange current information on a very short timescale as well as access and communicate the most recent data. This ensures that a uniform level of knowledge and information is available worldwide.

🔗 *Innovations – progressive and future-oriented*

With more than 2 300 patent applications a year and over 24 000 active patents and patent applications, Schaeffler ranks second among Germany's most innovative companies, according to the German Patent and Trademark Office. This makes us one of the most innovative leaders in the industry.

 **1**
Rolling bearings for the machine generation Industry 4.0 – measurable added value through the digital functional expansion of products



000A6684

Quality

 *Quality – precise and reliable*

Our manufacturing expertise and holistic quality management system ensure a level of product quality that far exceeds the industry average. “Zero defects” is our objective. We have matched all our processes to this target. In addition, our many years of experience in forming, forging, heat treatment, surface technologies, grinding, honing and assembly ensure that our products fulfil the high quality level.

 *Numerous awards for Schaeffler products*

Ongoing quality inspections are a defined component of the manufacturing process. These are integrated as a feedback function in the manufacturing process. As a result, all products continuously fulfil the same high standard of quality. This high standard of quality is verified by numerous awards and certificates to international standards.



All Schaeffler locations worldwide are certified in accordance with DIN EN ISO 9001:2008, ISO/TS 16949:2009. With the validation and certification of our manufacturing sites, we are taking a pioneering role in environmental protection. All larger manufacturing sites are certified to ISO 14001 and are also validated in accordance with the more stringent EC ECO Management and Audit Scheme (EMAS).

 *Inner ring of a spherical roller bearing under quality control*



Worldwide presence

 *Close proximity to the customer worldwide in engineering and production*

Close proximity to our customers is just one of the defining characteristics of Schaeffler. With around 170 locations worldwide, we are right there where our customers need us. We offer engineering, production and service on the ground, in the region and for the region. Together with our customers, we develop exactly those solutions that precisely fulfil the necessary functions and thus contribute to perfect meshing of all the components. In this way, our individually applied know-how sustainably supports the valuable brand promise of our customers. Our manufacturing locations provide seamless supply through short response times and customer-oriented service.

 *Schaeffler locations worldwide*



Product Catalogue HR 1

Rolling Bearing Catalogue HR 1 – the Engineering Compendium

Catalogue HR 1 is a fundamental information, selection and advisory tool for technical issues relating to the wide-ranging field of rotary rolling bearings. Since its first appearance, it has become established worldwide as an important engineering compendium for the calculation and design of rolling bearing arrangements. It describes the rolling bearings in accordance with DIN EN ISO that are required for original equipment manufacture, distribution and the aftermarket, specific rolling bearing accessories and further rolling bearing types and design variants. It shows which products can be considered for a bearing arrangement, the factors that must be taken into consideration in the design, the tolerances required on the adjacent construction and how the bearing arrangement is sealed. It gives detailed information on the calculation of bearing rating life, on temperatures and loads, on the lubricants that are most suitable for the bearing arrangement and, last but not least, on the correct mounting and maintenance of the products.

The catalogue has been completely revised

The catalogue has been completely revised in comparison with the previous valid edition. The emphasis in this revision was not simply on the updating of technical information and the inclusion of new products, but also on achieving the best possible ease of use for our customers. Among the volume of changes, the following examples can be given: as far as possible, the chapters now have the same structure. As a result, information applicable to multiple chapters is easier to find. Pictograms give simpler navigation within the book and contribute to better understanding of the data and descriptions. Selection matrices at the start of the product chapters provide clear and concise information on specific product features, thus allowing the designer to quickly make a preliminary assessment of whether the bearing is fundamentally suitable for the envisaged application. In terms of the sequence of information, the structure of the dimension tables now follows standard practice in the design of a rolling bearing arrangement. Links make reference to relevant electronic media and lead directly there.

Current level of technology and manufacture

The data in the catalogue represent the current level of technology and manufacture as of June 2018. They reflect not only progress in rolling bearing technology but also the experience gathered from numerous applications. Any data in earlier publications that do not correspond to the data in this catalogue are therefore invalid.

Benefits to you

Catalogue HR 1 stands for pioneering bearing arrangement technology, application-focussed representation, the highest product and performance density and continuous development. The benefits to you:

- Selection of products from a vast product range
- Maximum benefit, since the most suitable product is used in the right place
- Extensive worldwide product availability
- Short delivery times
- Long-term supply capability
- Security of planning for the long view
- Simplified stockholding
- Market-competitive prices
- Global service
- Comprehensive, application-focussed advice.



This catalogue essentially describes standard products. Since these are used in numerous applications, we cannot make a judgement as to whether any malfunctions will cause harm to persons or property. It is always and fundamentally the responsibility of the designer and user to ensure that all specifications are observed and that all necessary information is communicated to the end user. This applies in particular to applications in which product failure and malfunction may constitute a hazard to human life.

Other product publications

Other technical publications

This catalogue contains a large proportion of the core rotary rolling bearing range of the brands INA and FAG. Furthermore, we develop and manufacture many other products and systems that are of significant interest in terms of technical progress and cost-effectiveness for rotary and linear bearing arrangements as well as for the automotive sector. These are covered in separate technical publications that can be obtained upon request.

Product ranges for specific market sectors

Special product ranges are available for specific market sectors. In addition to standard products, these also include special solutions. The range extends from simple, application-specific bearings via complete, ready-to-fit systems to special solutions that can be used to fulfil the most complex bearing technology requirements with high functional security and cost-effectiveness. Contact our Application Support Service at the earliest possible stage and benefit from the broad knowledge and considerable experience of these specialists for your projects.

Mobility for Tomorrow

Our objective: to fulfil tomorrow's challenges in partnership with you

Globalisation, urbanisation, digitalisation, scarcity of resources and the growing demand for affordable mobility are leading to increasingly dynamic market requirements. As a leader in innovation and technology, we have been making an important contribution to the mobility of the future for many years. With our products and our knowledge, we can continue to fulfil the challenges of your market in relation to rolling bearing arrangements in partnership with you. To this end, this catalogue is an important instrument.

Mobility of the future



1 X-life

X-life

Schaeffler X-life rolling bearings of the brands INA and FAG are products with a particularly high performance density, which are identified by the premium brand XL. Their enhanced quality and performance are not, however, a special additional technical feature, which is available as an optional addition to a standard bearing design, but are fundamentally the Schaeffler standard for these products.

 **World leader**

With its extensive range of X-life bearings, Schaeffler is a leader in the premium products segment over comparable competitors.

 **The success of X-life is signified by four factors**

The high performance standard of rolling bearings is achieved through the systematic use of state-of-the-art production techniques and extensive changes to the internal construction of the bearing **► 10 |  1.**

 **1**
X-life premium quality, achieved by means of extensive technical enhancements to the products



 **The more favourable load distribution in the bearing results in a higher dynamic load carrying capacity**

These design and production engineering measures lead to better and more uniform surfaces and contact zones, resulting in a considerable improvement in load distribution within the bearing and a significant reduction in frictional torque. This in turn leads to higher basic dynamic load ratings compared to the previous standard and thus to a longer bearing operating life **► 10 |  2.**

 **2**
Cylindrical roller bearing with cage: comparison of basic dynamic load rating C_r with bearings without X-life quality

C_r = radial basic dynamic load rating

- ① Bearing without X-life quality
- ② X-life cylindrical roller bearing

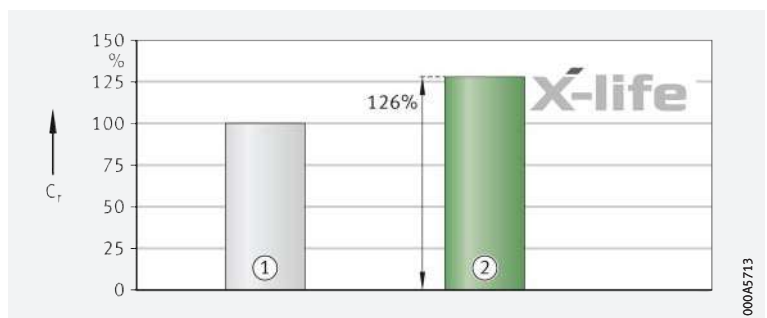

1.1 Advantages for the user

Significantly increased customer benefits due to X-life

If a current standard bearing is substituted for an X-life bearing, this will give the designer a completely new level of design ► 10 | 3 and ► 11 | 3:

- First of all, he will benefit from the longer bearing rating life and the extension of the maintenance intervals. This in turn improves the “Total Cost of Ownership” and the reliability of the specific machine or equipment.
- However, he can also use the higher basic load rating to place higher loads on the bearings, while achieving the same rating life.
- If he keeps to the old load and rating life, he can use a smaller bearing in place of the previous size and thus make the overall design more compact and lower in mass.

Additional advantages

Other arguments in favour of using X-life bearings are their lower friction and lower noise levels, properties that are of central importance for many applications.

Lower operating costs, higher machine availability

In conclusion, X-life characteristics improve the overall cost-efficiency of a bearing position significantly and thus bring about a sustainable increase in the efficiency of the machine and equipment ► 11 | 3.



X-life rolling bearings in this catalogue include the suffix XL in the designation. The bearings are described in detail in the specific product chapters.

Extensive customer benefits of X-life

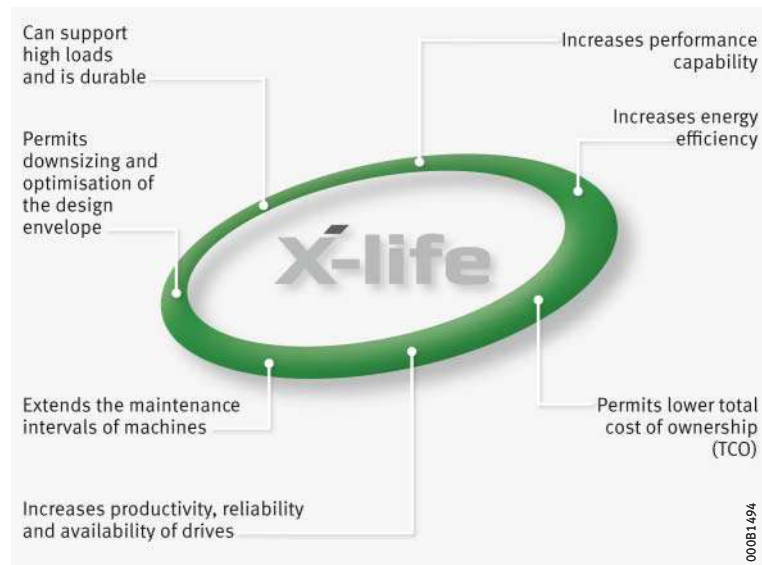

2 medias professional

🔗 *medias can be used for dynamic selection of bearings for an application*

🔗 *The link to the program*

🔗 *medias address*

🔗 *Expanded area of application*

🔗 *Calculations can be carried out quickly with BEARINX*

🔗 *Comprehensive, reliable, fast, digital*

medias professional, the proven selection and information system, presents the INA and FAG catalogue products in electronic format. As with the printed catalogue, this gives our customers product information on both brands in a single data source. This saves time and gives easier handling.

medias professional is available online; see link. The program is available in several languages, is easy to navigate and is particularly clear thanks to the use of numerous pictures, diagrams and models. There are also highly representative application examples, classified by market sector.

medias ► <https://medias.schaeffler.com>

Datasheets on the bearing series can be generated as PDF files. It includes a lubricant database and also the web2CAD link for direct download and inclusion of 3D models.

medias professional focusses on the individual bearing. The complete shaft can be simulated and any influences arising from its deformation on the bearings can be determined using the calculation program BEARINX. This program can also be made available to direct customers as BEARINX-online via the Internet (for conditions, see the INA/FAG homepage).

In conclusion, **medias professional** is a comprehensive, reliable system to help you help yourself answer many questions on rolling bearing technology by electronic means, quickly and at any location.

2.1 medias

🔗 *Product characteristics, design envelope and basic load ratings*

The **medias** homepage guides the user dynamically by means of the product characteristics to delimitation according to design envelope and/or basic load ratings through to selection of the suitable rolling bearing from predetermined designs ► 12 | 1 to ► 13 | 4.

1 medias homepage

Rapid bearing selection by means of dynamic method

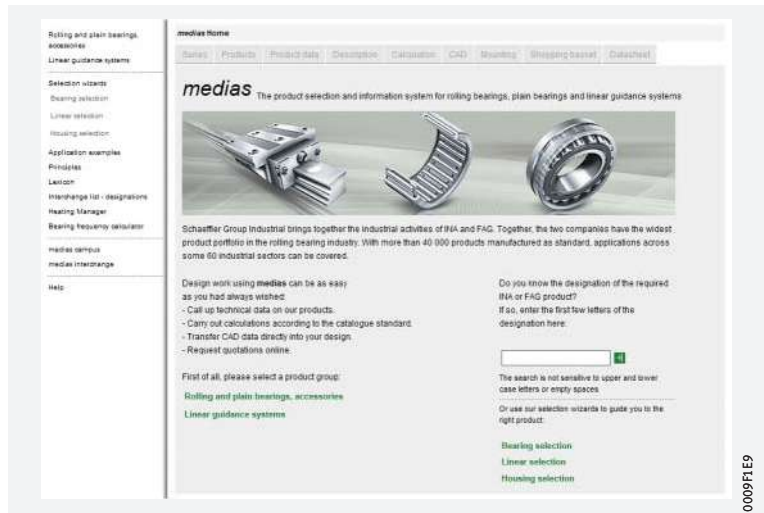



Bearing selection in accordance with product characteristics

Load directions, angular defects and misalignments (dynamic, static), sealing, corrosion protection etc.

Bearing selection

Characteristics, types | Design envelope, load ratings | Hits per page: 10 50 100 | Hits: 12255

Select one or more bearing characteristics:

- Radial load
- Axial load in one direction
- Axial load in two directions
- Moments about all axes
- Static angular error and misalignment
- Dynamic angular error and misalignment
- Sealed on one side
- Sealed on both sides
- Not sealed
- Protected against rust
- Lifetime lubrication, freedom from maintenance
- Grease lubrication
- Oil lubrication
- Small design envelope
- One way chain
- Split
- Large bearing

Select one or more bearing types:

- Deep groove ball bearings
- Radial insert ball bearings
- Angular contact ball bearings
- Spindle bearings
- Four point contact bearings
- Self-aligning ball bearings
- Thin section bearings
- Cylindrical roller bearings
- Needle roller and cage assemblies
- Drawn cup needle roller bearings with open ends
- Drawn cup needle roller bearings with closed end
- Needle roller bearings (machined)
- Aligned needle roller bearings
- Tapered roller bearings
- Spherical roller bearings
- Barrel roller bearings
- Toroidal roller bearings
- Axial deep groove ball bearings
- Axial angular contact ball bearings
- Axial cylindrical roller bearings
- Axial needle roller bearings
- Axial spherical roller bearings
- Axial angular contact roller bearings
- Angular contact ball bearings
- Needle roller/cylindrical roller bearings
- Needle roller/cylindrical roller bearings
- Axial/hybrid roller bearings
- Axial conical thrust cage needle roller bearings
- Crossed roller bearings
- Bearings for screw drives
- Rotary table bearings
- Slowing rings
- Roller clutches
- Vial type track rollers
- Stud type track rollers
- Track rollers
- Stud type track rollers
- Plan bushes
- Washers, strips
- Spherical plain bearings
- Rod ends

0009F1FB



Input of data relating to dimensions and basic load ratings

Bore diameter, outside diameter, width, basic load ratings

Bearing selection

Characteristics, types | Design envelope, load ratings | Hits per page: 10 50 100 | Hits: 2534

Restriction by means of design envelope and basic load ratings

Basic dynamic load rating C_2 or C_1 N
 Basic static load rating C_0 or C_0 N

Minimum mm mm
 Maximum mm mm

[Control] [Reset] [Back] [Search]

0009F20D



Input of data relating to dimensions and basic load ratings

Stepwise process with the aid of wizards leads to the required bearing

Bearing selection

Characteristics, types | Design envelope, load ratings | Hits per page: 10 50 100 | Hits: 2308

Restriction by means of design envelope and basic load ratings

Basic dynamic load rating C_2 or C_1 N
 Basic static load rating C_0 or C_0 N

Minimum mm mm
 Maximum mm mm

[Control] [Reset] [Back] [Search]

Page | 1 | 2 | 3 | 4 | 5 | 6 | 7 | 8 | 9 | 10 | ... | 231 |

Product	d mm	D mm	B mm	C_2 N	C_0 N	C_1 N	C_1 N	f_0 1/min	f_0 1/min	f_0 green 1/min	f_0 oil 1/min	Product description
545024X013	40	45	13	19000	25000	115000	6600					[View] [Add] [Remove]
545024X017	40	45	17	21400	41500	115000	8700					[View] [Add] [Remove]
545024X027	40	45	27	33000	73000	115000	8500					[View] [Add] [Remove]
HS6012	40	47	12	14000	24200	86000	5200					[View] [Add] [Remove]
HS6016-2RS	40	47	16	14000	24200	86000	5	3950				[View] [Add] [Remove]
HS6016	40	47	16	20000	39000	86000	1000					[View] [Add] [Remove]
TK6018-2RS	40	47	18	20000	38000		8	3950				[View] [Add] [Remove]
545024X18	40	47	18	25000	50000	115000	8300					[View] [Add] [Remove]
HS6025-2RS	40	47	25	26000	38500		8	3850				[View] [Add] [Remove]
BS6025	40	47	25	25500	52000	86000	4900					[View] [Add] [Remove]

Page | 1 | 2 | 3 | 4 | 5 | 6 | 7 | 8 | 9 | 10 | ... | 231 |

0009F21F

3 BEARINX



BEARINX is one of the leading programs for the calculation of rolling bearings. The program was developed at Schaeffler at the beginning of the 1990s and is a powerful tool for the design of rolling bearing arrangements in complex systems, starting from shaft and linear guidance systems through to sophisticated gearboxes ▶14|📄 1 and ▶15|📄 2. The bearings are not considered in a simple rigid, isolated form using reference conditions but at the location in the calculation model with the elasticities, loads and displacements that the complete system exerts on the bearing position.



In the in-house version, the detailed analysis options are available worldwide to every Schaeffler engineer. In line with the current status of standardisation, the adjusted reference rating life is calculated in accordance with ISO/TS 16281 and DIN 26281.

📄 Values taken into consideration in calculation using BEARINX

The calculation models take account of factors including:

- the nonlinear, elastic deflection behaviour of every individual rolling contact
- the elastic behaviour of shafts and housings (FE influencing factor matrices can be incorporated)
- the influences of fit, temperature and speed on the operating clearance or preload of the bearings and on contact angle
- the profiles of rollers and raceways or raceway oscillations
- the actual contact pressure taking account of the misalignment and profiling of rolling elements
- the influence of lubrication, contamination and actual contact pressure on the fatigue life.



Manual automotive gearbox in elastic housing

Source: General Motors

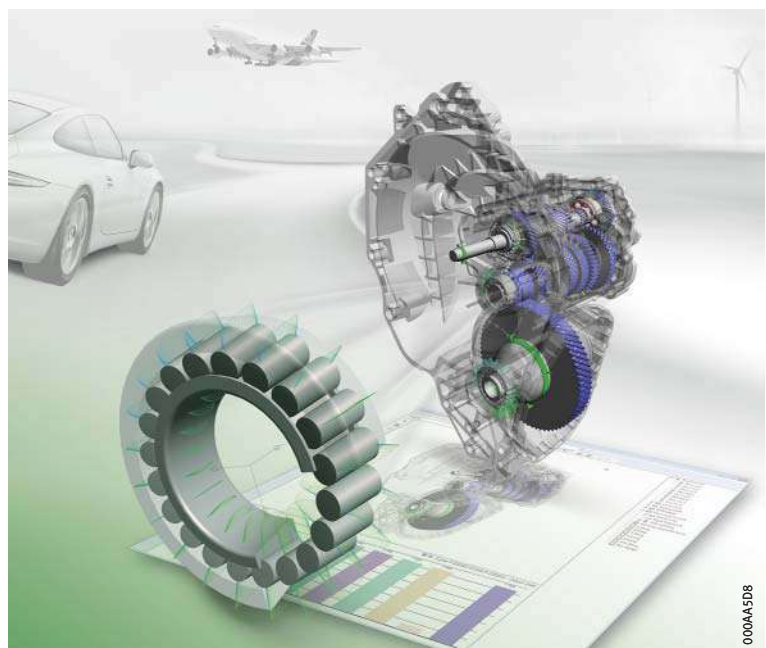

000AA5D8

🔗 *Further calculation possibilities with BEARINX*

Optional calculation options, including:

- frictional torque calculation
- rotor dynamics
- export options, for example to BEARINX-MAP (three-dimensional bearing maps for further processing in MBS programs).

🔗 *Documentation of the results*

Comprehensive documentation of results with diagrams, tables, graphics and animations of the model allow appropriate presentation of the design to the customer.

3.1 BEARINX customer versions

🔗 *Customer versions: calculation modules derived from the in-house version*

In order that selected customer groups can assure themselves of our calculation possibilities in BEARINX and can be included intensively and at an early stage as a development partner in product development, Schaeffler makes available calculation modules derived from the in-house version

➤ <https://www.schaeffler.de/Calculation>:

🔗 *Calculation possibilities matched to various target groups*

- BEARINX-online Easy Module for “everyone”
 - BEARINX-online Easy Linear
 - BEARINX-online Easy Friction
 - BEARINX-online Easy Linearsystem
 - BEARINX-online Easy Ballscrew
 - BEARINX-online Easy RopeSheave
 - BEARINX-online Easy EMachine
 - BEARINX-online Easy Pump
- BEARINX-online calculations for Schaeffler customers, sales partners and colleges
 - BEARINX-online Shaft Calculation
 - BEARINX-online Spindle Calculation
 - BEARINX-online Linear Calculation
- BEARINX-VIP as a local version for development partners.



When finalising the design, it is recommended that the in-house version should be used in order to benefit from the advisory and calculation services of Schaeffler.



Calculation of a planetary gearbox for a wind turbine using BEARINX

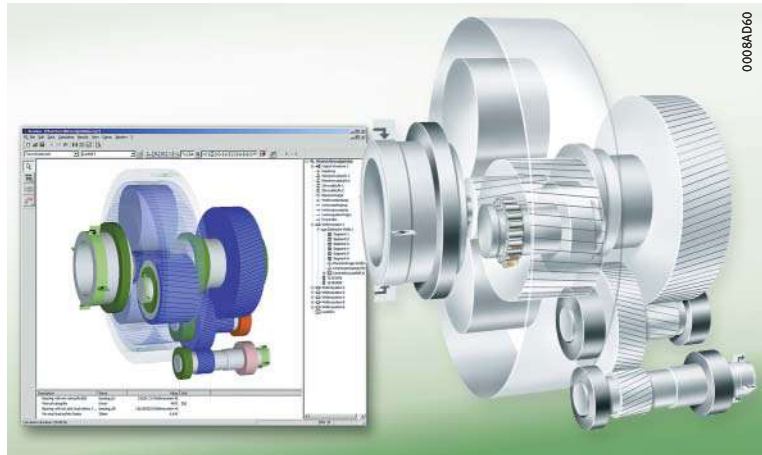

🔗 *Can be used free-of-charge by colleges*

Colleges in particular can benefit from our offering, since BEARINX-online calculations can be made available free of charge for educational purposes.



Information about the customer versions and the possibility of applying for registration/usage can be found on the Schaeffler Internet portal at:

➤ <https://www.schaeffler.de/Calculation>

3.2 BEARINX-online Shaft Calculation

The customer himself can model and investigate complex shaft systems

The customer version used most often is the BEARINX-online Shaft Calculation ▶16| 3. It is derived from the system level of the in-house version and offers the customer the possibility of modelling coaxially nested shaft systems himself online and analysing variants.



As in the case of the in-house version, BEARINX-online Shaft Calculation makes it possible to determine precisely the load distribution in the rolling bearing, taking account of shaft deflection and the nonlinear deflection behaviour of the rolling contacts.

3
Shaft calculation and bearing selection with BEARINX – screen representation

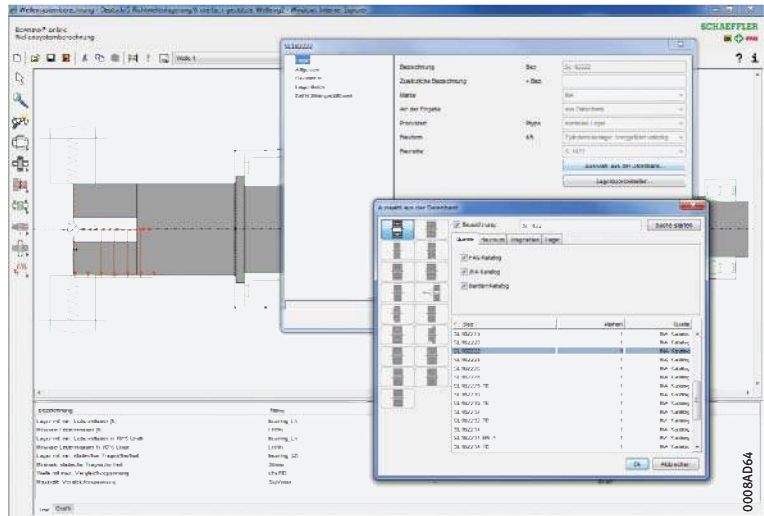

Bearing selection is carried out by means of a product database to which BEARINX is linked

The BEARINX customer versions access a bearing database which holds all catalogue bearings of the Schaeffler brands. Special bearings are available by agreement. The internal component data, which are stored in non-viewable form, are incorporated in the rating life calculation. As a result, the quality of the calculation results is significantly higher than those of a bearing approximation, since the profile data not only of the raceways but also of the rolling elements are taken into consideration. BEARINX-online Shaft Calculation – an overview:

Extract from the performance portfolio of online shaft calculation using BEARINX

- Simple modelling of shaft systems with the aid of wizards
- Calculation of the adjusted reference rating life in accordance with DIN 26281 (ISO/TS 16281)
- Results documentation can be stored locally
- Graphical representation of shaft reactions (shaft deflection and shaft inclination)
- Calculation of bearing rigidity at the operating point (optional)
- Rigid and elastic adjustment of bearings in the relevant shaft system
- Operating clearance calculation by means of wizards.



Use is regulated by contract and requires initial participation in a training course and payment of a fee to cover costs. No maintenance or licence fees are incurred.



The calculations are performed online. There is no need for installation at the customer. The application files are stored for each customer in a separate directory on a powerful calculation server. Where necessary, application files can be interchanged: the customer can request checking of his calculation model or, vice versa, the Schaeffler engineering service can provide an application file or a special bearing.

4 Criteria for bearing selection

4.1

Features of individual bearing types

📖 *HR 1 contains an extensive range of bearing types*

The Schaeffler catalogue HR 1 describes a multitude of bearing types, from which the designer can choose the one that best suits his needs. Due to the variety of applications and the different influences on the bearing position, it is not, however, possible to give generally applicable rules here for the selection of the bearing type. When deciding on a specific bearing type, it is often necessary to weigh up several criteria.

📖 *Factors that are usually important in the selection of bearings*

The aim of the following descriptions is to assist the designer. They make reference to factors that play a primary role in the selection of the bearing type. More precise data on the individual bearing types, their characteristics and the available designs can be found in the specific product chapters.

📖 *Product matrix*

Important features of the bearing types are described in an overview in the matrix [▶ 30](#)  1.

📖 *Criteria for selection of bearing type*

Product characteristics that can play a role in selection of the bearing type are, for example:

- the available design envelope [▶ 18](#)
- the load values, load directions and the bearing arrangement concept (arrangement of the bearings) [▶ 20](#)
- the speeds of the bearings [▶ 24](#)
- the accuracy of the bearings [▶ 24](#)
- the axial displacement capability of the bearing rings (non-locating bearing function) [▶ 25](#)
- the compensation of misalignments [▶ 26](#)
- quiet running [▶ 27](#)
- the rigidity of the bearing arrangement [▶ 28](#)
- the friction in the bearings [▶ 28](#)
- the mounting and dismounting of the bearings [▶ 28](#)
- the sealing of the bearings and of the bearing position
- the lubrication of the bearings.



This catalogue does not give the entire range of Schaeffler rolling bearings. Dedicated catalogues and technical descriptions are generally available for products which are not described here. These publications can be requested from Schaeffler: [▶ https://www.schaeffler.de/std/1D51](https://www.schaeffler.de/std/1D51).

4.2 Comparison of design envelope for particular bearing types

In many applications, it is frequently the case that one of the main dimensions of the rolling bearing is fixed by the overall design of the machine or piece of equipment. Due to the strength specifications of the shaft, this is generally the bore diameter of the bearing.

Bearings for small and large shaft diameters

For small shaft diameters, suitable bearings are ball bearings – especially deep groove ball bearings – and needle roller bearings. Where large diameters are present, the bearings available are cylindrical, tapered, spherical and toroidal roller bearings, as well as deep groove ball bearings, but not excluding needle roller bearings.

Comparison of cylindrical roller bearings

A load carrying capacity of approximately the same magnitude can be achieved both with bearings that are narrow and have a large outside diameter and also with bearings that are wide and have a smaller outside diameter.



1
Cylindrical roller bearings with approximately comparable basic load rating C_0

SL183026 has a full complement roller set

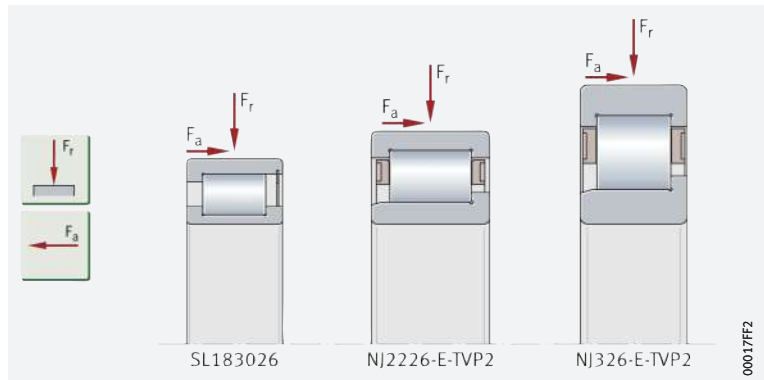

Low cross-sectional height and high load carrying capacity

Bearings with small cross-sectional height

If the design envelope is restricted in a radial direction – for example in high performance gearboxes for vehicles – bearings with a small cross-sectional height such as roller and needle roller and cage assemblies, drawn cup needle roller bearings with or without an inner ring, are particularly suitable [▶ 18](#) | [☞ 2](#). These bearings have high radial load carrying capacity due to the line contact with low section height.



2
Bearings with small cross-sectional height – comparison of radial section height

- ① Needle roller and cage assembly
- ② Drawn cup needle roller bearing with open ends
- ③ Needle roller bearing without inner ring
- ④ Needle roller bearing with inner ring

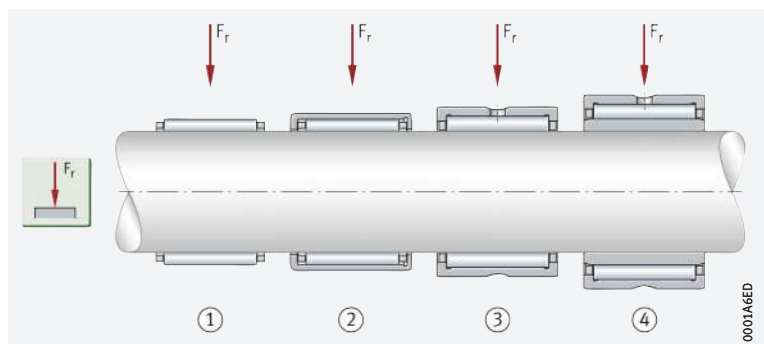

Bearings for small axial design envelope and combined load

Bearings with small axial design envelope and combined load

If the design envelope is small in an axial direction, the bearings suitable for bearing positions subjected to radial and axial load are certain series of cylindrical roller bearings – e.g. semi-locating bearings NJ in conjunction with deep groove ball bearings or combined needle roller bearings

► 19 | 3 and ► 19 | 4.



3
Semi-locating bearing for supporting axial forces in one direction in conjunction with a deep groove ball bearing

- ① Cylindrical roller bearing NJ (semi-locating bearing)
- ② Deep groove ball bearing (locating bearing, functioning here as a semi-locating bearing)

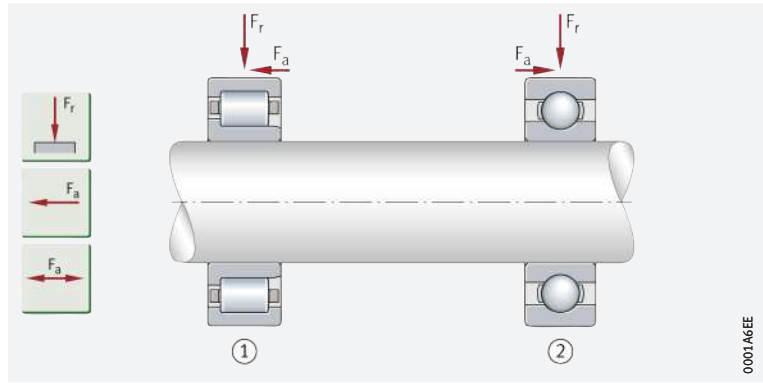

0001A6EE



4
Combined needle roller bearings for supporting high radial forces and axial forces in one or both directions

- ① Needle roller/axial deep groove ball bearing, without inner ring, without end cap for axial forces in one direction
- ② Needle roller/angular contact ball bearing with inner ring, for axial forces in both directions

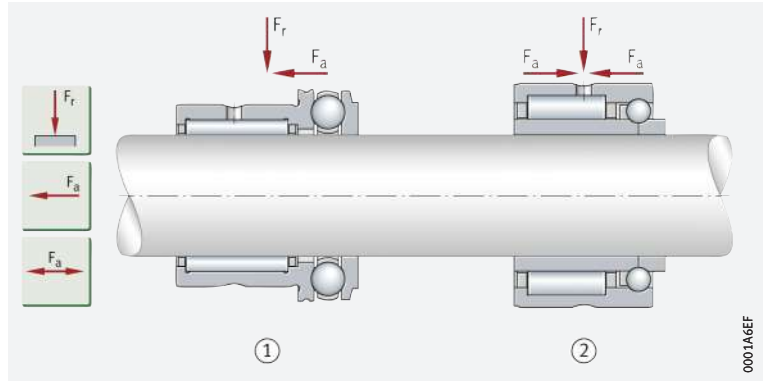

0001A6EF

Bearings with pure axial load carrying capacity

Bearings for bearing arrangements under axial load only

If the bearing arrangement is under axial load only, suitable bearings are axial needle roller and axial cylindrical roller and cage assemblies, axial needle roller and axial cylindrical roller bearings and axial deep groove ball bearings with a small axial section height



5
Axial bearings – comparison of cross-sections

- ① Axial needle roller and cage assembly
- ② Axial needle roller bearing
- ③ Axial deep groove ball bearing
- ④ Axial cylindrical roller bearing

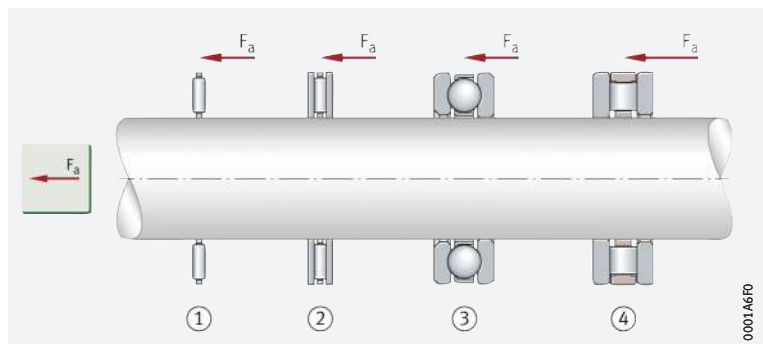

0001A6FD

4.3 Load value and load directions

The load determines the type and size of the bearing

Influence of load on bearing type and bearing size

The bearing size is normally determined by the external load $\blacktriangleright 20 | \text{ } \text{ } 6$. In selection of the bearing, it must be noted that roller bearings can be subjected to higher loads due to the line contact than ball bearings of the same size.

6
Radial load carrying capacity – comparison of deep groove ball bearing/cylindrical roller bearing

- ① Deep groove ball bearing – lower radial load carrying capacity
- ② Cylindrical roller bearing NU – higher radial load carrying capacity

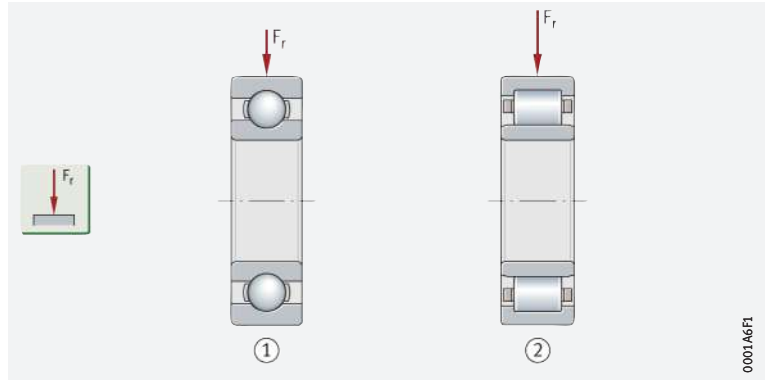

In the case of radial loads, the forces act perpendicular to the bearing axis

Bearings for predominantly radial loads

If radial loads (so-called transverse forces) are present – these are forces perpendicular to the longitudinal axis of the shaft – bearings are used that support exclusively or predominantly radial forces, which are therefore radial ball bearings and radial roller bearings.

Cylindrical roller bearings N and NU, needle roller and cage assemblies, drawn cup needle roller bearings with open ends, needle roller bearings and toroidal roller bearings can support radial forces only $\blacktriangleright 20 | \text{ } \text{ } 7$.

7
Radial bearings, bearings for predominantly radial load

- ① Deep groove ball bearing, open
- ② Angular contact ball bearing
- ③ Cylindrical roller bearing NU
- ④ Tapered roller bearing
- ⑤ Spherical roller bearing

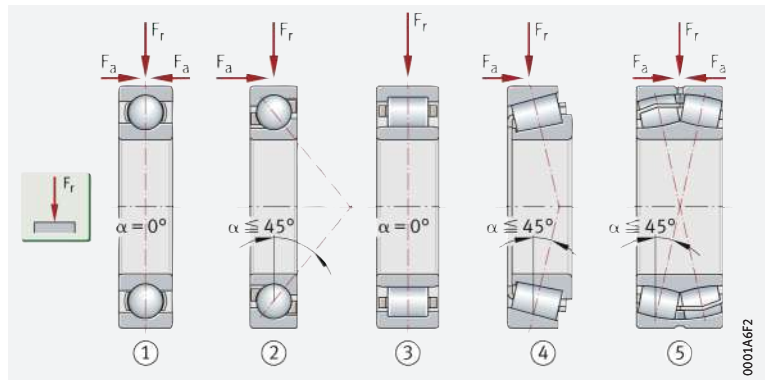

Bearings for predominantly axial loads

If mainly axial forces are present – these are forces in the direction of the longitudinal axis of the shaft – bearings are used that support exclusively or predominantly axial forces.

☞ *Low to moderate axial loads* If low to moderate pure axial loads are present, suitable bearings are axial deep groove ball bearings and four point contact bearings ▶ 21 | 8. If axial load in one direction is present, single direction axial deep groove ball bearings can be used.

☞ *Moderate to high axial loads* If moderate to high axial loads in one direction are present, the bearings available are axial needle roller bearings, axial cylindrical roller bearings, axial tapered roller bearings and axial spherical roller bearings ▶ 21 | 8. Axial cylindrical roller bearings or axial spherical roller bearings arranged adjacent to each other in pairs are suitable for high axial loads of alternating direction.

8 Bearings for predominantly axial load

- ① Axial deep groove ball bearing, single direction
- ② Axial angular contact ball bearing, double row, double direction
- ③ Axial needle roller bearing, single direction
- ④ Axial cylindrical roller bearing, single direction
- ⑤ Axial spherical roller bearing

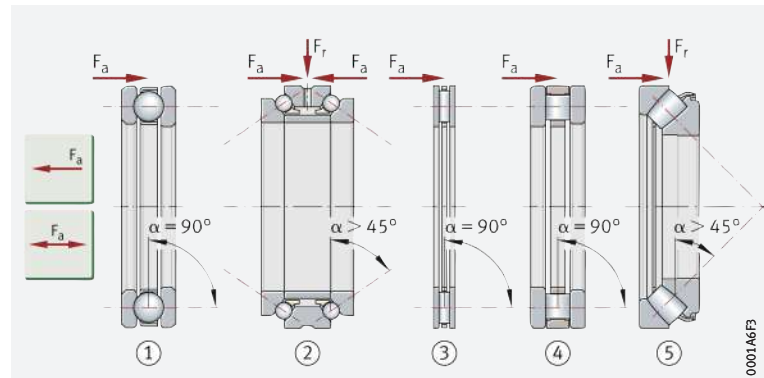

Bearings for combined loads

Certain rolling bearings can be subjected to combined loads (radial and axial).



The axial load carrying capacity of a bearing is determined by the nominal contact angle α . The greater this angle, the higher the axial load carrying capacity of the bearing. An indication of its axial load carrying capacity is also provided by the bearing-specific axial load factor Y in the product tables; the smaller this factor, the higher the axial load capacity.

☞ *Suitable bearings for combined load*

Suitable bearings are deep groove ball bearings, four point contact bearings, single and double row angular contact ball bearings, spherical roller bearings and single row tapered roller bearings ▶ 22 | 9. Self-aligning ball bearings and cylindrical roller bearings NJ (semi-locating bearing) and NU (locating bearing) + L-section ring HJ (= semi-locating bearing unit) ▶ 22 | 10 can also be used.



Axial loads present in one direction only can be supported by single row angular contact ball bearings and tapered roller bearings, cylindrical roller bearings NJ as well as NU + HJ and axial spherical roller bearings. For alternating load directions, these bearings must always be mounted with a second bearing (the second bearing must provide support in the opposing direction). For mounting in sets, single row angular contact ball bearings as universal bearings and matched tapered roller bearing sets comprising two single bearings are available.

9

Bearings for combined load

- ① Deep groove ball bearing
- ② Four point contact bearing
- ③ Single row angular contact ball bearing
- ④ Double row angular contact ball bearing
- ⑤ Tapered roller bearing
- ⑥ Spherical roller bearing

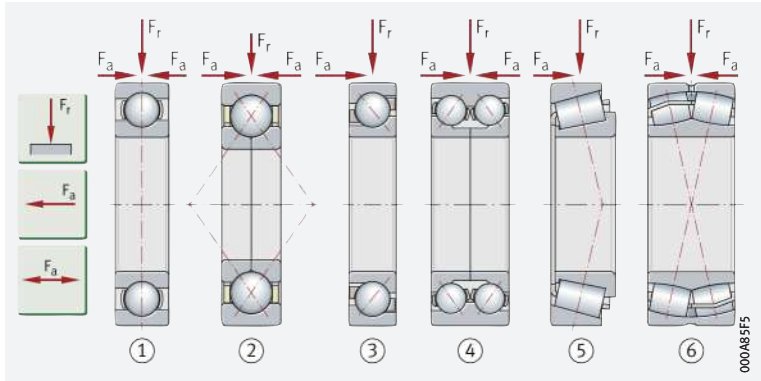

10

Bearings for combined load

- ① Self-aligning ball bearing (locating bearing)
- ② Cylindrical roller bearing NJ (semi-locating bearing)
- ③ Cylindrical roller bearing NUP (locating bearing)
- ④ Cylindrical roller bearing NJ + HJ (locating bearing)
- ⑤ Cylindrical roller bearing NU + HJ (semi-locating bearing)

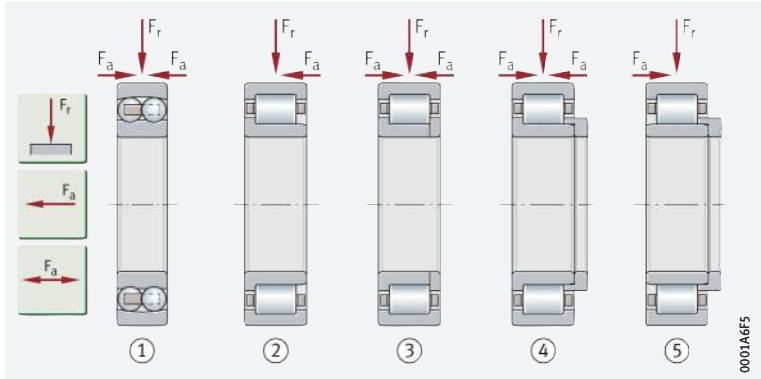

The axial load can also be supported by means of a separate bearing

If the axial load component is too high, the axial load can also be supported by means of a separate bearing. In addition to a pure axial bearing, radial bearings – e.g. deep groove ball bearings and cylindrical roller bearings ▶ 22 | **11** or four point contact bearings capable of supporting axial forces in both directions – can be used.



If the four point contact bearing is to be used as an axial bearing only, the outer ring must have radial clearance in the housing.

11

Cylindrical roller bearing and four point contact bearing for supporting combined load

- ① Cylindrical roller bearing NU, radial bearing
- ② Four point contact bearing, axial bearing (the outer ring must not be radially retained if the bearing is subjected to purely axial load)

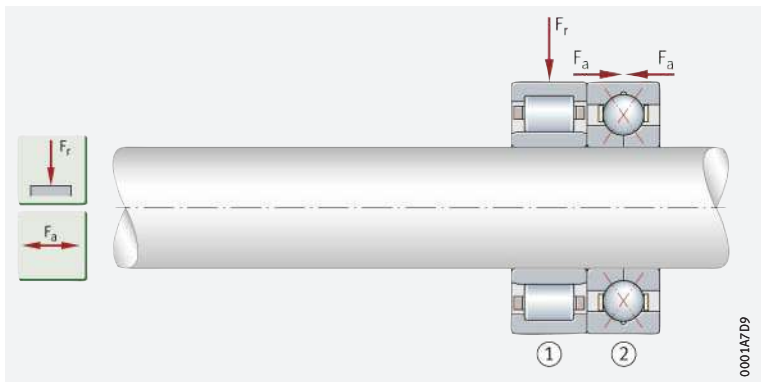

Moment load under eccentric force application

Bearings for supporting tilting moments

If a load acts eccentrically, the bearing is subjected to tilting moments. In addition to double row deep groove ball bearings and angular contact ball bearings, suitable bearings in this case are in particular the single row angular contact ball bearings or tapered roller bearings matched in and X or O arrangement **► 23** | **12**.

12

Bearings for supporting tilting moments

M = tilting moment

- ① Angular contact ball bearing, double row
- ② Angular contact ball bearing set, comprising two matched single row angular contact ball bearings, O arrangement
- ③ Tapered roller bearing set, comprising two matched single row tapered roller bearings, X arrangement

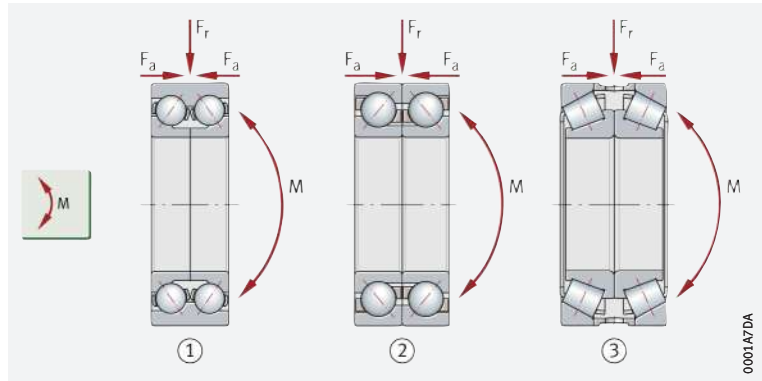

0001A7DA

Double row deep groove ball bearing

In **► 23** | **13**, the tilting moment produced by the eccentrically acting force F is supported by a double row deep groove ball bearing.

13

Unilateral bearing arrangement of shaft

M = tilting moment

F = eccentrically acting radial force

- ① Deep groove ball bearing, double row

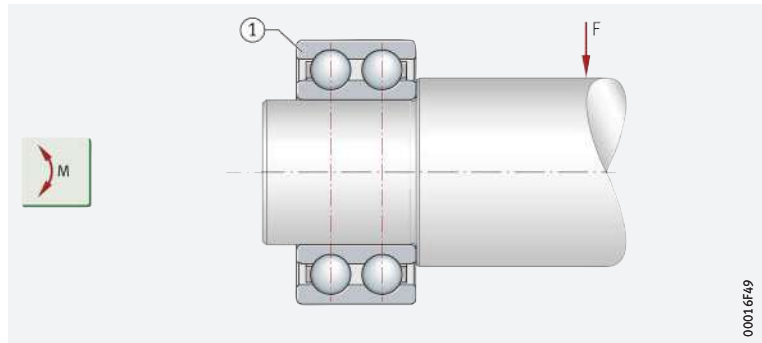

00016F49

4.4 Speed suitability

☞ *The permissible speed is restricted by the operating temperature*

☞ *Bearings for very high speeds*

Bearings for high and very high speeds

In general, the highest speed achievable by rolling bearings is determined by the permissible operating temperature. This is dependent on the frictional heat generated in the bearing, the heat introduced from external sources and the heat dissipated from the bearing arrangement. When conditions are in equilibrium, the bearing temperature is constant.

The highest speeds are achieved by single row bearings with particularly low friction. Under pure radial load, these are open deep groove ball bearings, while under combined load they are angular contact ball bearings ► 24 | ☞ 14.



Due to their design, the permissible speeds for axial bearings are generally lower than those for radial bearings.

☞ 14 Bearings for high and very high speeds

- ① Deep groove ball bearing, single row, open
- ② Angular contact ball bearing, single row, open

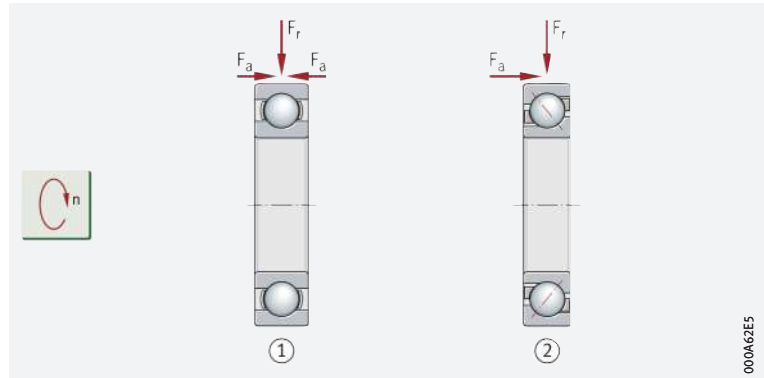

4.5 Accuracy

☞ *Bearings with increased accuracy*

For most applications, the normal dimensional and running accuracy of rolling bearings is sufficient (tolerance class Normal). Where there are increased demands on running accuracy and in bearing arrangements with very high speeds, such as in the case of main spindles for machine tools, bearings with increased accuracy are necessary ► 1172.

4.6 Axial displacement facility

☞ *Axial displacement occurs within the bearing*

Compensation within the bearing

A shaft is normally supported using a locating bearing and a non-locating bearing. The locating bearing gives tight axial guidance of the shaft in both directions. Non-locating bearings can be displaced in an axial direction and thus prevent the locating bearing and non-locating bearing from bracing against each other. In this way, non-locating bearings compensate for changes in axial length and thermal elongation ▶ 25 | ☞ 15.

☞ **15**

Cylindrical roller bearing NU, non-locating bearing, length compensation within bearing

s = axial displacement distance

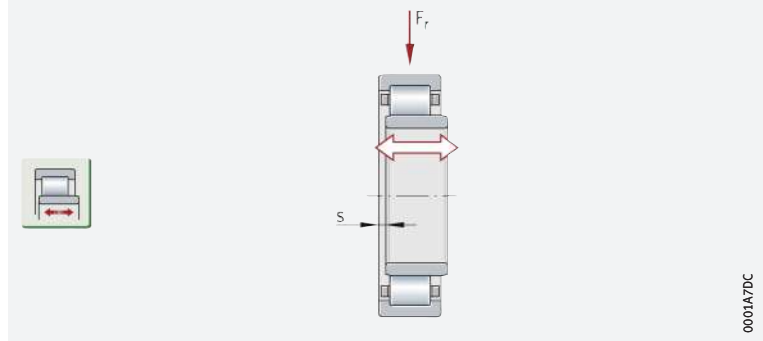

0001A7DC

☞ *Suitable non-locating bearings for compensation within the bearing*

Bearings suitable as non-locating bearings for compensations with the bearing include, in particular, cylindrical roller bearings NU and N with one ribless ring (inner or outer ring), cylindrical roller bearings NJ, some designs of full complement cylindrical roller bearings (SI bearings), needle roller bearings and toroidal roller bearings ▶ 25 | ☞ 16.

☞ **16**

Non-locating bearings for compensation within bearing

- ① Needle roller bearing
- ② Cylindrical roller bearing NU
- ③ Cylindrical roller bearing N
- ④ Cylindrical roller bearing SL0248
- ⑤ Toroidal roller bearing

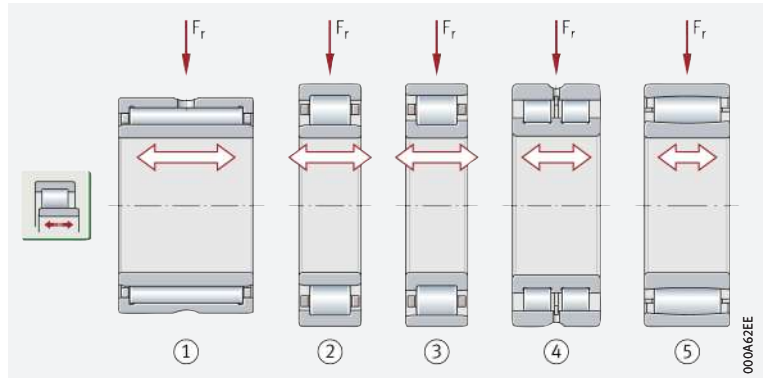

000A62EE

Compensation by means of sliding seat on a bearing ring

! Non-separable bearings such as deep groove ball bearings and spherical roller bearings can also be used as non-locating bearings. However, one of the two bearing rings must then have a loose fit and must not be in axial contact, so that the relevant ring can be displaced on the seating surface **► 26** | **17**.

17

Length compensation by means of sliding seat

s = axial displacement distance (loosely fitted bearing ring)

- ① Spherical roller bearing, outer ring capable of displacement (with loose fit)
- ② Deep groove ball bearing, inner ring capable of displacement (with loose fit)

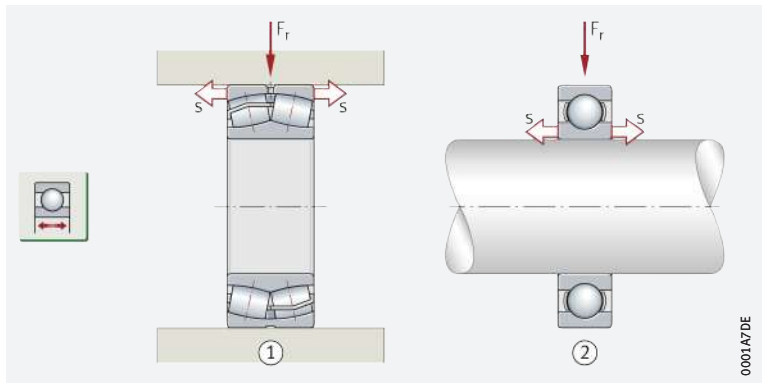

4.7 Compensation of misalignments

Skewing has a negative effect on bearing function and reduces the bearing operating life

If skewing occurs between the shaft and housing – for example if bearing seats are not aligned, the shaft deforms under load or the bearing positions are a considerable distance apart – this must be compensated by means of suitable bearings (self-aligning bearings). Misalignments should also be expected if individual housings, such as plummer block or flanged housings, are used. Similar effects (alignment inaccuracies of the bearing positions) are caused by angular defects between the radial seating surface and the lateral contact surface of a rolling bearing ring.

Dynamic and static compensation of misalignments and angular defects

Self-aligning rolling bearings

Misalignments and angular defects can be compensated within certain limits by means of self-aligning rolling bearings (see product chapter). These include bearings such as barrel roller bearings, spherical roller bearings, self-aligning ball bearings, toroidal roller bearings and axial spherical roller bearings **► 26** | **18**. These bearings have a concave outer ring raceway in which the inner ring together with the rolling element set can swivel.

! The rings may only be swivelled while being simultaneously rotated, otherwise the raceways will be damaged.

18

Bearings for static and dynamic adjustment motions

- ① Barrel roller bearing (non-locating bearing)
- ② Spherical roller bearing (locating bearing)
- ③ Self-aligning ball bearing (locating bearing)
- ④ Toroidal roller bearing (non-locating bearing)

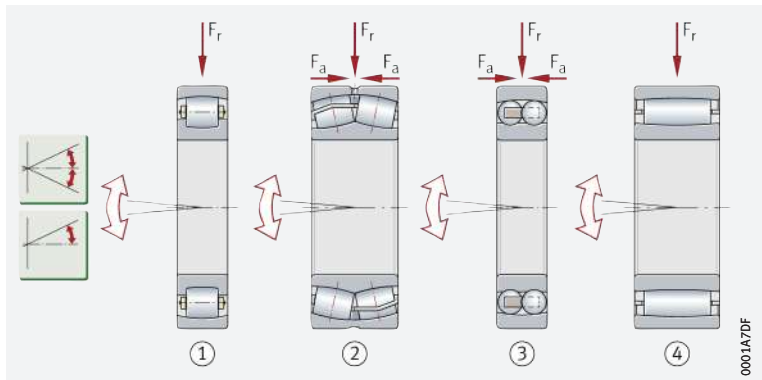

Radial insert ball bearings and aligning needle roller bearings are suitable for static adjustment motions

Bearings for compensation of static angular defects

Radial insert ball bearings and aligning needle roller bearings have a crowned (spherical) outer ring outside surface and can align themselves on the concave mating surface after mounting ▶ 27 | 19. These bearings are suitable for static adjustment motions. They must not, however, be used for dynamic adjustment motions, oscillating motions etc.



Axial deep groove ball bearings

Axial deep groove ball bearings cannot support tumbling motion of the shaft and therefore react with high sensitivity to angular defects.

Bearings with spherical housing locating washer

If the contact surface in the housing is not perpendicular to the rotational axis of the bearing, the angular defect can be compensated by means of axial deep groove ball bearings with a spherical housing locating washer and support washer ▶ 27 | 19.



19 Bearings for static angular defects (adjustment motions)

- 1 Radial insert ball bearing (radial bearing)
- 2 Aligning needle roller bearing (radial bearing)
- 3 Axial deep groove ball bearing with spherical housing locating washer and support washer

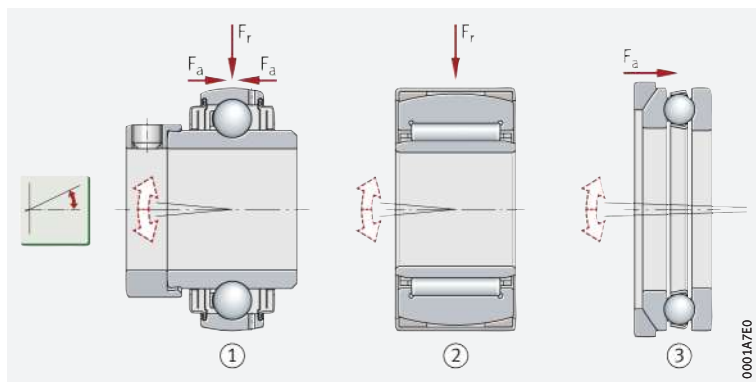

0001A7E0

Single row deep groove ball bearings have only a small self-alignment facility

Self-alignment facility of deep groove ball bearings

In deep groove ball bearings, misalignments lead to unfavourable running of the balls and induce additional loads in the bearing that shorten the operating life of the bearing. In order to keep these loads at a low level, only small adjustment angles are therefore permitted as a function of the load for single row deep groove ball bearings.



Double row deep groove ball bearings cannot undergo angular motion. When using these bearings, therefore, misalignments are not permissible.

Self-alignment facility of cylindrical roller bearings, tapered roller bearings, needle roller bearings

The self-alignment facility is smaller than in the case of deep groove ball bearings

The self-alignment facility of cylindrical, tapered and needle roller bearings is smaller than that of deep groove ball bearings. The transverse form of the rolling elements and raceways of these roller bearings is designed such that, at the stated adjustment angles, the load on the material at the rolling contact is still uniform enough that the basic rating life is not impaired.



Where angular defects are larger than those indicated in the product chapters, rollers and needle rollers are no longer subjected uniformly to load over their full length. As a result, unacceptably high edge pressures may occur.

4.8 Quiet running

Deep groove ball bearings have very low running noise

In small electrical devices, such as office equipment or household applications, low running noise is often required. Deep groove ball bearings are particularly suitable for such requirements ▶ 24 | 14. A noise evaluation of the series is permitted by means of the Schaeffler Noise Index ▶ 69. It is advantageous to apply axial adjustment to the bearings, for example by means of disc springs.

4.9 Rigidity

☞ *Roller bearings are more rigid than ball bearings*

The rigidity of a rolling bearing is determined by the type, bearing size and operating clearance. The rigidity increases with the number of rolling elements supporting the load. A particularly high level of system rigidity is the objective, for example in main spindle bearing arrangements and rotary table bearing arrangements in machine tools and in pinion bearing arrangements.



The rigidity of roller bearings is higher, due to the contact conditions between the rolling elements and raceways (line contact), than the rigidity of ball bearings.

4.10 Friction

☞ *Bearings with low bearing friction*

In addition to the introduction and dissipation of heat, the decisive factor for the operating temperature of a bearing arrangement is bearing friction. Bearings with particularly low friction include open deep groove ball bearings, single row angular contact ball bearings and cylindrical roller bearings with cage under radial load ▶ 20 | ☞ 7 and ▶ 24 | ☞ 14. Comparatively high friction is generated in bearings with contact seals, full complement cylindrical roller bearings and axial roller bearings.

4.11 Mounting and dismounting

☞ *In the case of separable bearings, the bearing rings can be mounted independently of each other*

Separable (non self-retaining) and non-separable bearings

Bearings that are not self-retaining simplify the mounting and dismounting of bearings, since the bearing parts can be mounted individually. This is also an advantage if both rings have a tight fit. Separable bearings include four point contact bearings, double row angular contact ball bearings with a split inner ring, certain cylindrical roller bearings, tapered roller bearings, axial deep groove ball bearings, axial spherical roller bearings, axial cylindrical roller bearings and certain needle roller bearings ▶ 28 | ☞ 20.



Separable bearings

- ① Cylindrical roller bearing NU
- ② Tapered roller bearing
- ③ Axial deep groove ball bearing

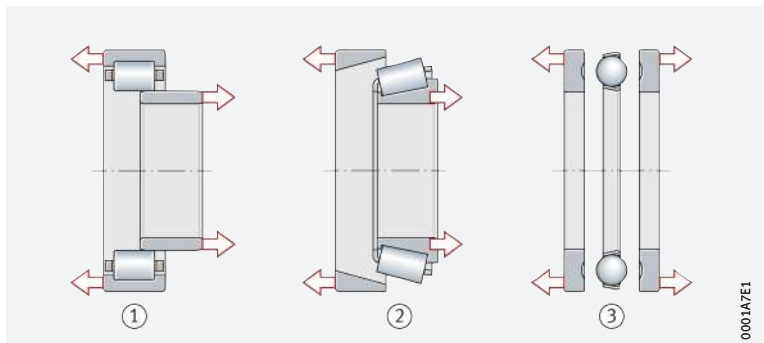

☞ *Non-separable bearings*

Deep groove ball bearings, single row angular contact ball bearings, self-aligning ball bearings, barrel roller bearings and spherical roller bearings are not generally separable.

☞ *With a tapered shaft seat, the radial internal clearance in the bearing can be set to a defined value*

☞ *Mounting and dismounting of bearings can be aided by means of adapter and withdrawal sleeves*

21

Bearings with tapered bore, adapter and withdrawal sleeve

- ① Cylindrical roller bearing, double row
- ② Self-aligning ball bearing with adapter sleeve
- ③ Spherical roller bearing with withdrawal sleeve

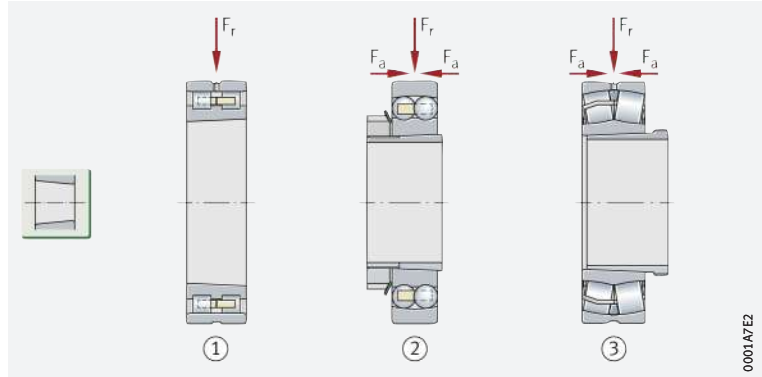

4.12

Matrix for preselection of bearing type

☞ *Suitable for an initial preliminary assessment*

☞ *Limits of the matrix*

The matrix shows the features and characteristics of common bearing types ▶30| 1. It can be used to make an initial preliminary assessment of whether the selected bearing is suitable for the application.

If the focus is on criteria that cannot be resolved using the matrix, technical advice should be sought from Schaeffler. This also covers new types of bearing arrangements where relevant experience is not available or is insufficient, or where applications run under extreme operating conditions, high safety requirements apply or a possible risk to personal safety is involved.

When using the matrix, it must also be taken into consideration that certain characteristics are not dependent exclusively on the bearing type. For example, the preload of a tapered roller bearing arrangement may influence the rigidity of the bearing arrangement. This cannot, however, be derived from the matrix. A similar situation is present in the case of spindle bearings for the support of main spindles in machine tools. Depending on whether the bearings are designed with steel or ceramic balls, the preload may increase at very high speeds due to the high centrifugal forces in the bearing – the centrifugal forces act on the rolling elements and change their position in the bearing. In hybrid bearings – bearings with ceramic balls – this effect is far less pronounced than in bearings with steel balls.

In selection of the bearing type, attention must also be paid to the work involved in mounting and dismounting of the bearings, the costs of the bearing arrangement and the availability of the bearings. Decisions cannot be made on these points by means of the matrix.

1
Bearing types, designs and characteristics

The matrix gives an overview of the types and design features of rolling bearings.

































It can be used to make a preliminary assessment of whether a bearing is fundamentally suitable for the envisaged application.

The additional information provided in the product chapter and in the Technical principles must, however, be observed in addition to this overview in selection of the bearing.

Design features and suitability			Radial bearings				
			Deep groove ball bearings	Angular contact ball bearings	Four point contact bearings	Self-aligning ball bearings	Cylindrical roller bearings, non-locating
+++ extremely suitable ++ highly suitable + suitable (+) suitable with restrictions - not suitable/not applicable ✓ available							
Load carrying capacity	radial		++	++	(+)	++	+++
	axial, one direction		++ ¹⁾	++	++	(+)	-
	axial, both directions		++ ¹⁾	++	++	(+)	-
	moments		+ ¹⁾	++ ¹⁾	(+)	-	-
Compensation of angular misalignments	static		(+) ¹⁾	-	-	+++	(+)
	dynamic		(+) ¹⁾	-	-	+++	(+)
Bearing design	cylindrical bore		✓	✓	✓	✓	✓
	tapered bore		-	-	-	✓	-
	separable		-	✓ ¹⁾	✓	-	✓ ¹⁾
Lubrication	greased		✓ ¹⁾	✓ ¹⁾	-	✓ ¹⁾	-
Sealing	open		✓	✓	✓	✓	✓
	non-contact		✓ ¹⁾	✓	-	-	-
	contact		✓ ¹⁾	✓	-	✓ ¹⁾	-
Suitability for	high speeds		+++ ¹⁾	+++ ¹⁾	(+)	+	++
	high running accuracy		++	++ ¹⁾	(+)	-	++
	low-noise running		+++	++	(+)	(+)	+
	high rigidity		+	++	+	(+)	+++ ¹⁾
	reduced friction		+++	++	+	++	++
	length compensation within bearing		-	-	-	-	+++
	non-locating bearing arrangement		+	+	-	+	+++
	locating bearing arrangement		++	+++ ¹⁾	++	+	-
X-life bearings			-	✓ ¹⁾	✓ ¹⁾	-	✓ ¹⁾
Bearing bore ^{1) 2)} d in mm		from to	2 260	5 180	17 200	5 150	15 710
Product chapter		from page ▶	208	278	346	366	408

¹⁾ Certain bearing designs.

²⁾ Alternatively, inside diameter in bearings without an inner ring.

	Radial bearings									Axial bearings				
	Cylindrical roller bearings, semi-locating 	Cylindrical roller bearings, locating 	Tapered roller bearings 	Barrel roller bearings 	Spherical roller bearings 	Toroidal roller bearings 	Needle roller bearings: machined, drawn cup, cages 			Combined needle roller bearings 	Crossed roller bearings 	Axial deep groove ball bearings 	Axial cylindrical roller bearings 	
	+++	+++	+++	+++	+++	+++	+++	+++	++	-	-	-	+	
	+	+	+++	+	++	-	-	+++ ¹⁾	+++	++	++	++	+++	
	-	+	+++ ¹⁾	+	++	-	-	++ ¹⁾	+++	++ ¹⁾	-	-	-	
	-	-	(+)	-	-	-	-	-	++	-	-	-	-	
	(+)	(+)	(+)	+++	+++	+++	++ ¹⁾	-	-	(+) ¹⁾	-	-	+++	
	(+)	(+)	(+)	+	+	++	-	-	-	-	-	-	+	
	✓	✓	✓	✓	✓	✓	✓	✓	✓	✓	✓	✓	✓	
	-	-	-	✓	✓	✓	-	-	-	-	-	-	-	
	✓ ¹⁾	✓ ¹⁾	✓ ¹⁾	-	-	-	✓ ¹⁾	✓ ¹⁾	-	✓	✓	✓	✓	
	-	✓ ¹⁾	✓ ¹⁾	-	✓ ¹⁾	-	✓ ¹⁾	✓ ¹⁾	✓	-	-	-	-	
	✓	✓	✓ ¹⁾	✓	✓	✓	✓	✓	✓	✓	✓	✓	✓	
	-	-	-	-	-	-	-	-	-	-	-	-	-	
	-	✓ ¹⁾	✓ ¹⁾	-	✓ ¹⁾	-	✓ ¹⁾	-	-	-	-	-	-	
	++	++	+ ¹⁾	+	+	+ ¹⁾	+++	+++ ¹⁾	(+)	+	(+)	++	+	
	++	++	++	(+)	+ ¹⁾	++	++ ¹⁾	++ ¹⁾	++	+	++	-	+	
	(+)	(+)	(+)	(+)	+ ¹⁾	+	+	(+)	+	(+)	(+)	+	(+)	
	+++ ¹⁾	+++ ¹⁾	+++ ¹⁾	++	++	+++ ¹⁾	+++ ¹⁾	+++	+	++	++	+++	++	
	++	++	+	+	+	+ ¹⁾	++ ¹⁾	++ ¹⁾	+	+	(+)	+++	++	
	(+)	-	-	-	-	+++	+++ ¹⁾	(+)	-	-	-	(+)	-	
	+	-	(+) ¹⁾	+	+	+++	+++	-	-	-	-	-	-	
	+	++	+++	+	++	-	-	+ ¹⁾	+	+++	++	-	(+)	
	✓ ¹⁾	✓ ¹⁾	✓ ¹⁾	-	✓ ¹⁾	✓	✓ ¹⁾	✓	-	-	-	-	✓	X-life
	15 500	15 400	15 673,1	20 260	20 1800	70 900	2 415	7 70	70 500	10 260	15 320	4 160	60 1600	
	408	408	554	638	662	796	852	910	1138	1038	1072	1096	1114	

Technical principles

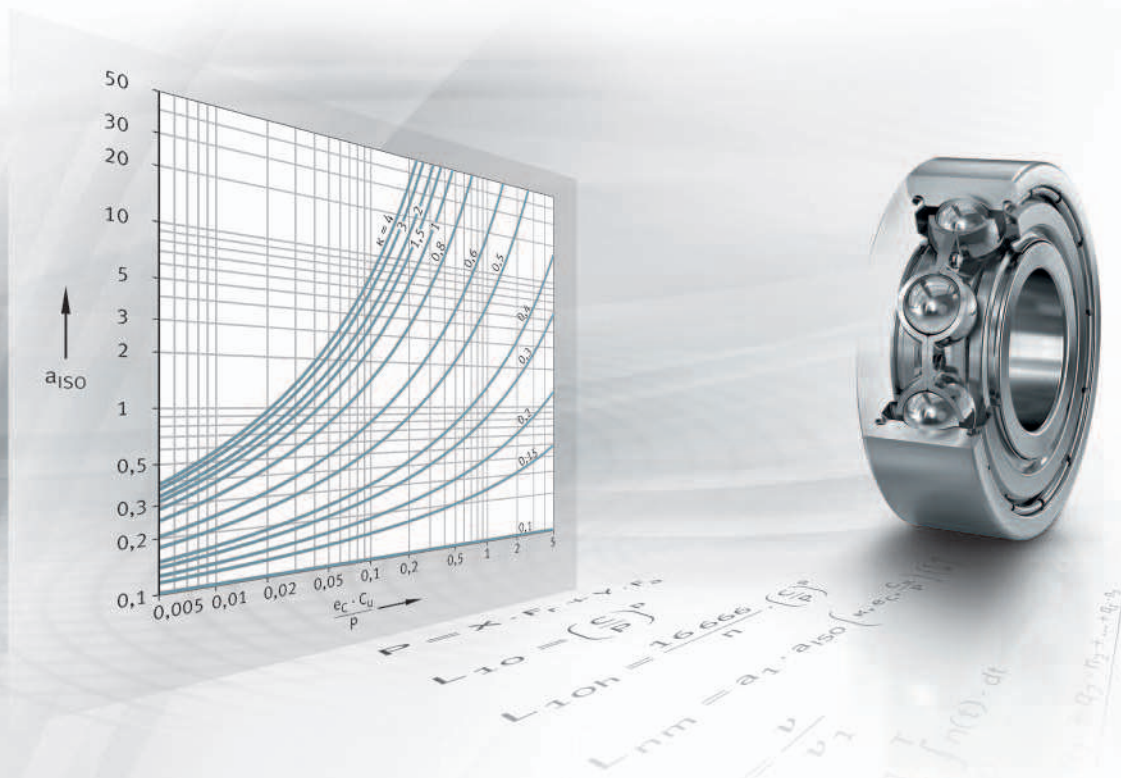

1 Load carrying capacity and life 34

- 1.1 Fatigue theory as a principle _____ 34
- 1.2 Dimensioning of rolling bearings _____ 34
- 1.3 Dynamic load carrying capacity and life _____ 34
- 1.4 Calculation of the rating life _____ 35
- 1.5 Basic rating life _____ 35
- 1.6 Equivalent dynamic bearing load _____ 36
- 1.7 Expanded adjusted rating life _____ 37
- 1.8 Requisite minimum load _____ 44
- 1.9 Equivalent operating values _____ 45
- 1.10 Guide values for dimensioning _____ 47
- 1.11 Static load carrying capacity _____ 52
- 1.12 Equivalent static bearing load _____ 53
- 1.13 Operating life _____ 53

2 Rigidity 54

- 2.1 Calculation of the radial or axial displacement _____ 54



3	Friction and increases in temperature	56	8	Design of bearing arrangements	139
3.1	Heat dissipation	56	8.1	Arrangement of bearings	139
3.2	Determining the friction values	56	8.2	Radial location of bearings	144
3.3	Load P_1 for ball bearings, tapered roller bearings, spherical roller bearings	61	8.3	Recommended fits	146
3.4	Frictional torque for axially loaded radial cylindrical roller bearings	62	8.4	Tables of fits	149
			8.5	Enveloping circle	167
			8.6	Dimensional, geometrical and running accuracy of mating parts	168
4	Speeds	64	8.7	Axial location of bearings	173
4.1	Limiting speed	64	8.8	Raceways with direct bearing arrangement	180
4.2	Thermal speed rating	64			
4.3	Thermally safe operating speed	65	9	Sealing of the bearing position	182
5	Noise	69	9.1	Non-contact seals	182
5.1	Schaeffler Noise Index	69	9.2	Contact seals	186
6	Lubrication	70	10	Mounting and dismounting	191
6.1	Basic principles	70	10.1	Handling	191
6.2	Grease lubrication	71	10.2	Guidelines for mounting	193
6.3	Oil lubrication	81	10.3	Accessories for mounting	194
6.4	Lubricating grease groups	90	10.4	Regulating the clearance during mounting	198
6.5	Arcanol rolling bearing greases	92	10.5	Accessories for dismounting	198
7	Bearing data	97	10.6	Special methods for mounting and dismounting	201
7.1	Main dimensions	97	10.7	Tools and methods for the mounting and dismounting of rolling bearings	205
7.2	Designation system	99			
7.3	Determining the bearing bore	103			
7.4	Radial internal clearance	103			
7.5	Operating clearance	104			
7.6	Axial internal clearance	106			
7.7	Bearing materials	108			
7.8	Cages	110			
7.9	Operating temperature	112			
7.10	Dimensional and running tolerances	114			
7.11	Chamfer dimensions	135			

1 Load carrying capacity and life

 “Expanded calculation of the adjusted rating life”

Schaeffler introduced the “Expanded calculation of the adjusted rating life” in 1997. This method was standardised for the first time in DIN ISO 281 Appendix 1 and has been a constituent part of the international standard ISO 281 since 2007. As part of the international standardisation work, the life adjustment factor a_{DIN} was renamed as a_{ISO} but without any change to the calculation method.

1.1 Fatigue theory as a principle



The basis of the rating life calculation in accordance with ISO 281 is Lundberg and Palmgren's fatigue theory which always gives a final rating life.

However, modern, high quality bearings can exceed by a considerable margin the values calculated for the basic rating life under favourable operating conditions. Ioannides and Harris have developed a further model for fatigue in rolling contact that expands on the Lundberg and Palmgren theory and gives a better description of the performance capability of modern bearings.

 Values which must be taken into account in the “Expanded calculation of the adjusted rating life”

The method “Expanded calculation of the adjusted rating life” takes account of the following influences:

- the bearing load
- the fatigue limit of the material
- the extent to which the surfaces are separated by the lubricant
- the cleanliness in the lubrication gap
- additives in the lubricant
- the internal load distribution and frictional conditions in the bearing.



The influencing factors, especially those relating to contamination, are extremely complex. A great deal of experience is essential for an accurate assessment. As a result, please consult Schaeffler for further advice.



The tables and diagrams in this chapter can only give guide values.

1.2 Dimensioning of rolling bearings

The required size of a rolling bearing is dependent on the demands made on its:

- rating life
- load carrying capacity
- operational reliability.

1.3 Dynamic load carrying capacity and life

 Basic dynamic load ratings

The dynamic load carrying capacity is described in terms of the basic dynamic load ratings. The basic dynamic load ratings are based on DIN ISO 281.

The basic dynamic load ratings for rolling bearings are matched to empirically proven performance standards published in previous FAG and INA catalogues.

The fatigue behaviour of the material determines the dynamic load carrying capacity of the rolling bearing.



- 📖 *Dynamic load carrying capacity*
- 📖 *Factors influencing the fatigue life*

The dynamic load carrying capacity is described in terms of the basic dynamic load rating and the basic rating life.

- 📖 *Basic dynamic load rating C*

The fatigue life is dependent on:

- the load
- the operating speed
- the statistical probability of the first appearance of failure.

The basic dynamic load rating C applies to rotating rolling bearings. It is:

- a constant radial load C_r for radial bearings
- a constant, concentrically acting axial load C_a for axial bearings.

The basic dynamic load rating C is that load of constant magnitude and direction which a sufficiently large number of apparently identical bearings can endure for a basic rating life of one million revolutions.

1.4 Calculation of the rating life

- 📖 *Calculation methods*

The methods for calculating the rating life are:

- basic rating life L_{10} and L_{10h} to ISO 281 ▶ 35 | f1 1 and ▶ 35 | f1 2
- expanded adjusted rating life L_{nm} to ISO 281 ▶ 37.

1.5 Basic rating life

- 📖 *L_{10} or L_{10h}*

The basic rating life in millions of revolutions (L_{10}) is determined in accordance with ▶ 35 | f1 1, the basic rating life in operating hours (L_{10h}) is determined in accordance with ▶ 35 | f1 2.

f1
Rating life
in revolutions

$$L_{10} = \left(\frac{C}{P} \right)^p$$

f2
Rating life
in operating hours

$$L_{10h} = \frac{16\,666}{n} \cdot \left(\frac{C}{P} \right)^p$$

Legend

L_{10}	10^6	The basic rating life in millions of revolutions, that is reached or exceeded by 90% of a sufficiently large number of apparently identical bearings before the first indications of material fatigue appear
L_{10h}	h	The basic rating life in operating hours, that is reached or exceeded by 90% of a sufficiently large number of apparently identical bearings before the first indications of material fatigue appear
C	N	Basic dynamic load rating, see product tables
P	N	Equivalent dynamic bearing load
p	–	Life exponent; for roller bearings: $p = 10/3$ for ball bearings: $p = 3$
n	min^{-1}	Operating speed (nominal speed).

1.6 Equivalent dynamic bearing load



The basic rating life L_{10} in accordance with ►35 | § 1 is defined for a load of constant magnitude acting in a constant direction. In the case of radial bearings, this is a purely radial load, while in the case of axial bearings it is a purely axial load.

☞ *Equivalent dynamic load P is identical to the combined load occurring in practice*

If the load and speed are not constant, equivalent operating values can be determined that induce the same fatigue as the actual loading conditions. Equivalent operating values for variable load and speed ►45 | 1.9.

Equivalent dynamic radial bearing load

The equivalent dynamic load P on a bearing subjected to combined load (with a radial and axial load) is calculated in accordance with ►36 | § 3.

§ 3
 Equivalent dynamic radial bearing load

$$P = X \cdot F_r + Y \cdot F_a$$

Legend

P	N	Equivalent dynamic radial bearing load
X	–	Radial load factor; see product tables
F_r	N	Radial load
Y	–	Axial load factor; see product tables
F_a	N	Axial load.



The calculation in accordance with ►36 | § 3 cannot be applied to radial needle roller bearings, axial needle roller bearings and axial cylindrical roller bearings. Combined loads are not permissible with these bearings. For radial needle roller bearings ►36 | § 4, for axial bearings ►36 | § 5.

§ 4
 Equivalent dynamic radial bearing load

$$P = F_r$$

Legend

P	N	Equivalent dynamic radial bearing load
F_r	N	Radial load.

Equivalent dynamic axial bearing load

☞ *In axial bearings with $\alpha = 90^\circ$, only axial loads are possible*

Axial deep groove ball bearings, axial cylindrical roller bearings, axial needle roller bearings and axial tapered roller bearings with the nominal contact angle $\alpha = 90^\circ$ can only support purely axial forces. For concentric axial load ►36 | § 5.

§ 5
 Equivalent dynamic axial bearing load

$$P_a = F_a$$

Legend

P_a	N	Equivalent dynamic axial bearing load
F_a	N	Axial load.

☞ *In axial bearings with $\alpha \neq 90^\circ$, axial and radial loads are possible*

Axial angular contact ball bearings, axial spherical roller bearings and axial tapered roller bearings with the nominal contact angle $\alpha \neq 90^\circ$ can support not only an axial force F_a but also a radial force F_r . The equivalent dynamic axial load P_a is thus determined in accordance with ►36 | § 6.

§ 6
 Equivalent dynamic axial bearing load

$$P_a = X \cdot F_r + Y \cdot F_a$$

Legend

P_a	N	Equivalent dynamic axial bearing load
X	–	Radial load factor; see product tables
F_r	N	Radial load
Y	–	Axial load factor; see product tables
F_a	N	Axial load.



1.7 Expanded adjusted rating life



The calculation of the expanded adjusted rating life L_{nm} was standardised for the first time in DIN ISO 281 Appendix 1 and included in the global standard ISO 281 in 2007. It replaces the previously used adjusted rating life L_{na} . Computer-aided calculation to DIN ISO 281 Appendix 4 has been specified since 2008 in ISO/TS 16281 and standardised in DIN 26281 since 2010.

The expanded adjusted rating life L_{nm} is calculated in accordance with [▶ 37 | 1.7](#).

 Expanded adjusted rating life

$$L_{nm} = a_1 \cdot a_{ISO} \left(\kappa, e_C, \frac{C_u}{P} \right) \cdot \left(\frac{C}{P} \right)^p$$

Legend

L_{nm}	10^6	Expanded adjusted rating life in millions of revolutions in accordance with ISO 281:2007
a_1	–	Life adjustment factor for a requisite reliability other than 90% ▶ 37 1.1
a_{ISO}	–	Life adjustment factor for operating conditions
κ	–	Viscosity ratio
e_C	–	Life adjustment factor for contamination
C_u	kN	Fatigue limit load; see product tables
C	kN	Basic dynamic load rating; see product tables
P	kN	Equivalent dynamic bearing load
p	–	Life exponent.

Fatigue limit load C_u



The fatigue limit load C_u in accordance with ISO 281 is defined as the load below which, under laboratory conditions, no fatigue occurs in the material. The fatigue limit load C_u serves as a calculation value for determining the life adjustment factor a_{ISO} and not as a design criterion. With poor lubrication or contamination of the lubricant in particular, it is also possible for the material to undergo fatigue at loads which are significantly below the fatigue limit load C_u .

Life adjustment factor a_1



The values for the life adjustment factor a_1 were redefined in ISO 281:2007 and differ from the previous data [▶ 37 | 1.1](#).

 Life adjustment factor a_1

Requisite reliability	Expanded adjusted rating life	Life adjustment factor
%	L_{nm}	a_1
90	L_{10m}	1
95	L_{5m}	0,64
96	L_{4m}	0,55
97	L_{3m}	0,47
98	L_{2m}	0,37
99	L_{1m}	0,25
99,2	$L_{0,8m}$	0,22
99,4	$L_{0,6m}$	0,19
99,6	$L_{0,4m}$	0,16
99,8	$L_{0,2m}$	0,12
99,9	$L_{0,1m}$	0,093
99,92	$L_{0,08m}$	0,087
99,94	$L_{0,06m}$	0,08
99,95	$L_{0,05m}$	0,077

Influences on the life adjustment factor

Life adjustment factor a_{ISO}

The standardised method for calculating the life adjustment factor a_{ISO} essentially takes account of:

- the load on the bearing
- the lubrication conditions (viscosity and type of lubricant, speed, bearing size, additives)
- the fatigue limit of the material
- the type of bearing
- the residual stress in the material
- the environmental conditions
- contamination of the lubricant.

f18
 Life adjustment factor for operating conditions

$$a_{ISO} = f \left[\frac{e_c \cdot C_u}{P}, \kappa \right]$$

Legend

a_{ISO}	–	Life adjustment factor for operating conditions ▶ 39 1 to ▶ 40 4
e_c	–	Life adjustment factor for contamination ▶ 43 2
C_u	N	Fatigue limit load; see product tables
P	N	Equivalent dynamic bearing load
κ	–	Viscosity ratio ▶ 41 For $\kappa > 4$ calculation should be carried out using $\kappa = 4$. This calculation method cannot be used for $\kappa < 0,1$.

Taking account of EP additives in the lubricant

In accordance with ISO 281, EP additives in the lubricant can be taken into consideration in the following way:

- For a viscosity ratio $\kappa < 1$ and a contamination factor $e_c \cong 0,2$, calculation can be carried out using the value $\kappa = 1$ for lubricants with EP additives that have proven effective. Under severe contamination (contamination factor $e_c < 0,2$), the effectiveness of the additives under these contamination conditions must be demonstrated. The effectiveness of the EP additives can be demonstrated in the actual application or on a rolling bearing test rig FE8 to DIN 51819-1.
- If the EP additives are proven effective and calculation is carried out using the value $\kappa = 1$, the life adjustment factor must be restricted to $a_{ISO} \cong 3$. If the value a_{ISO} calculated for the actual value κ is greater than 3, this value can be used in calculation.



For practical purposes, the life adjustment factor should be restricted to $a_{ISO} \cong 50$. This limit value also applies if $e_c \cdot C_u/P > 5$. For a viscosity ratio $\kappa > 4$, the value $\kappa = 4$ should be used; if $\kappa < 0,1$, the calculation is not valid.

The life adjustment factor a_{ISO} can – depending on the bearing type – be determined from ▶ 39 | 1 to ▶ 40 | 4.



1

Life adjustment factor a_{ISO} for radial roller bearings

- a_{ISO} = life adjustment factor
- C_u = fatigue limit load
- e_c = contamination factor
- P = equivalent dynamic bearing load
- κ = parameter for the lubrication regime (viscosity ratio)

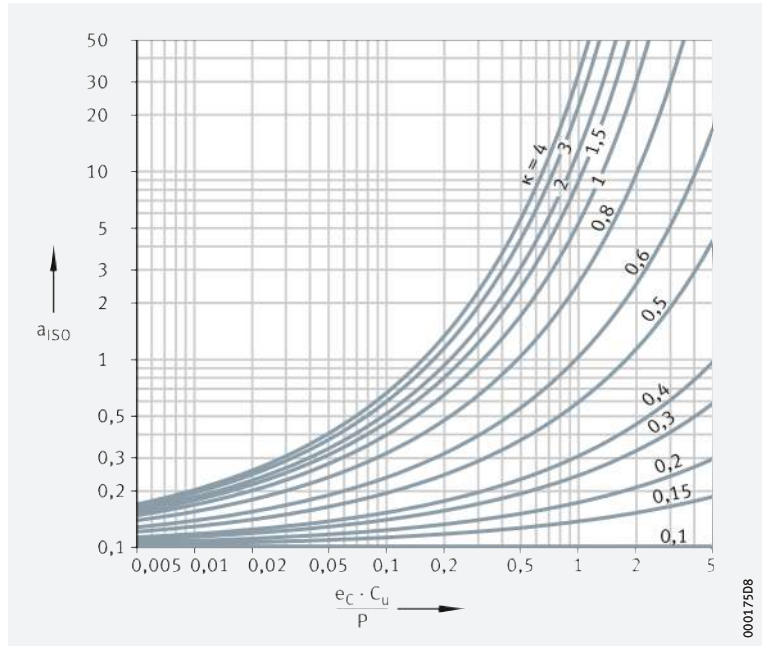

000175D8

2

Life adjustment factor a_{ISO} for axial roller bearings

- a_{ISO} = life adjustment factor
- C_u = fatigue limit load
- e_c = contamination factor
- P = equivalent dynamic bearing load
- κ = parameter for the lubrication regime (viscosity ratio)

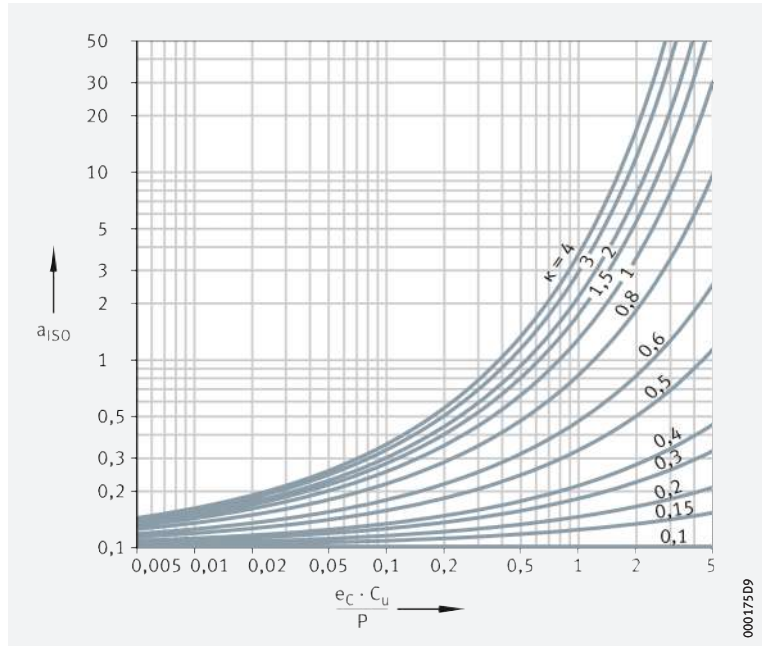

000175D9

3

Life adjustment factor a_{ISO} for radial ball bearings

- a_{ISO} = life adjustment factor
- C_u = fatigue limit load
- e_c = contamination factor
- P = equivalent dynamic bearing load
- κ = parameter for the lubrication regime (viscosity ratio)

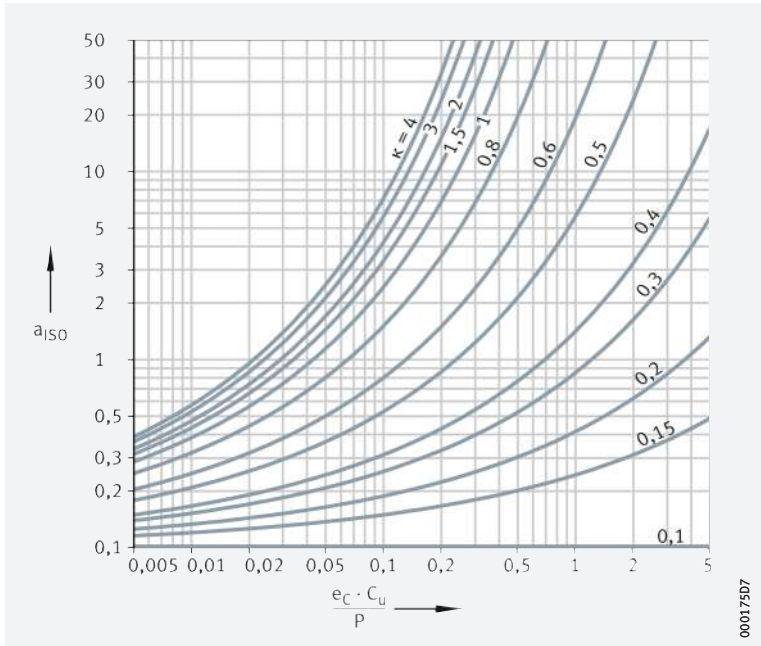

000175D7

4

Life adjustment factor a_{ISO} for axial ball bearings

- a_{ISO} = life adjustment factor
- C_u = fatigue limit load
- e_c = contamination factor
- P = equivalent dynamic bearing load
- κ = parameter for the lubrication regime (viscosity ratio)

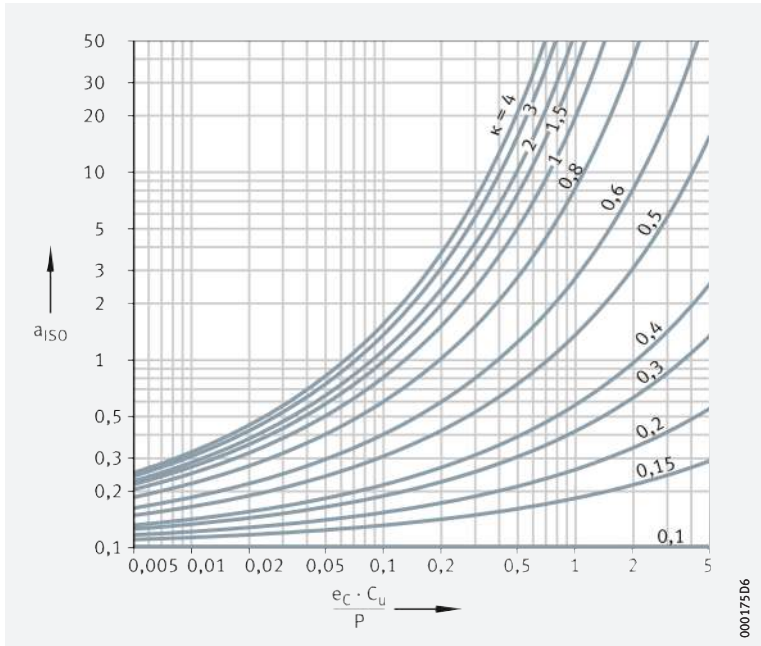

000175D6



Viscosity ratio κ

The viscosity ratio κ is an indication of the quality of lubricant film formation ▶ 41 | § 9.

§ 9
Viscosity ratio

$$\kappa = \frac{\nu}{\nu_1}$$

Legend

κ	–	Viscosity ratio
ν	mm ² /s	Kinematic viscosity of the lubricant at operating temperature
ν_1	mm ² /s	Reference viscosity of the lubricant at operating temperature.

☞ **Reference viscosity** The reference viscosity ν_1 is determined from the mean bearing diameter $d_M = (D + d)/2$ and the operating speed n ▶ 42 | § 5.

☞ **Nominal viscosity** The nominal viscosity of the oil at +40 °C is determined from the required operating viscosity ν and the operating temperature ϑ , ▶ 42 | § 6.
In the case of greases, ν is the operating viscosity of the base oil.

In the case of heavily loaded bearings with a high proportion of sliding contact, the temperature in the contact area of the rolling elements may be up to 20 K higher than the temperature measured on the stationary ring (without the influence of any external heat sources).



Taking account of EP additives in calculation of the expanded adjusted rating life L_{nm} ▶ 38.

☞ ν_1 for $n < 1000 \text{ min}^{-1}$ or $n \geq 1000 \text{ min}^{-1}$

The reference viscosity ν_1 is calculated for $n < 1000 \text{ min}^{-1}$ in accordance with ▶ 41 | § 10, for $n \geq 1000 \text{ min}^{-1}$ in accordance with ▶ 41 | § 11.
By differentiating between these cases, the effect of starvation at high speeds is taken into account.

§ 10
Reference viscosity

$$\nu_1 = 45\,000 \cdot n^{-0,83} \cdot d_M^{-0,5}$$

§ 11
Reference viscosity

$$\nu_1 = 4\,500 \cdot n^{-0,5} \cdot d_M^{-0,5}$$

Legend

ν_1	mm ² /s	Reference viscosity of the lubricant at operating temperature
n	min ⁻¹	Operating speed
d_M	mm	Mean bearing diameter $d_M = (D + d)/2$.

☞ ν_1 for synthetic oils In accordance with ISO 281:2007, the equations ▶ 41 | § 10 and ▶ 41 | § 11 can also be used in approximate terms for synthetic oils, such as oils based on synthetic hydrocarbons (SHC) for example.

5

Reference viscosity ν_1

- ν_1 = reference viscosity
- d_M = mean bearing diameter;
($d + D$)/2
- n = operating speed

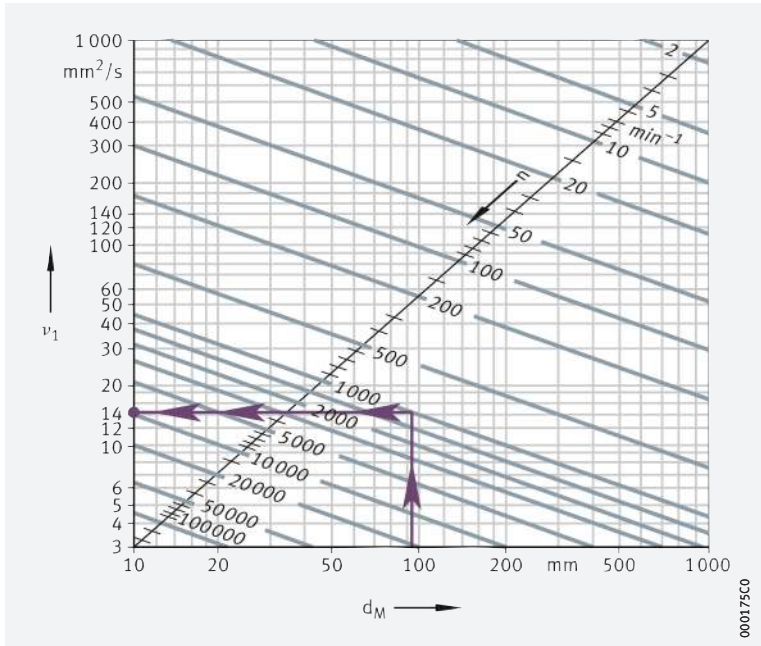

6

ν/ϑ diagram for mineral oils

- ν = operating viscosity
- ϑ = operating temperature
- ν_{40} = viscosity at +40 °C

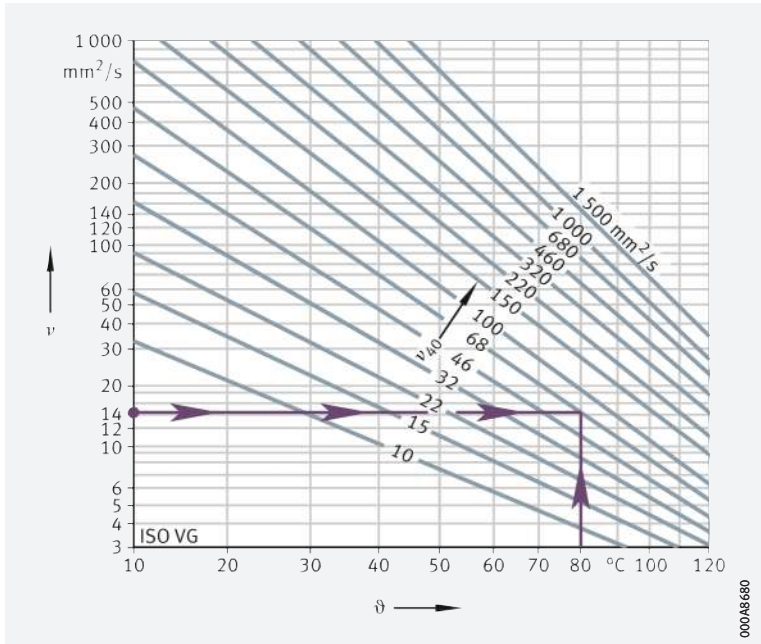



Contamination factor e_C

Life adjustment factor for contamination

The life adjustment factor for contamination e_C takes account of the influence of contamination in the lubrication gap on the rating life $\gg 43 \text{ | } \text{2}$.

The rating life is reduced by solid particles in the lubrication gap and is dependent on:

- the type, size, hardness and number of particles
- the relative lubrication film thickness
- the bearing size.



Due to the complex interactions between these influencing factors, it is only possible to give approximate guide values. The values in the tables are valid for contamination by solid particles (factor e_C). No account is taken of other contamination such as that caused by water or other fluids. Under severe contamination ($e_C \rightarrow 0$) the bearings may fail due to wear. In this case, the operating life is substantially less than the calculated life.



$\gg 43 \text{ | } \text{2}$ shows guide values for the contamination factor e_C . The values are given in DIN ISO 281. An aid to selecting the appropriate cleanliness class is given in DIN ISO 281 Appendix 3. This appendix also gives guidance on achieving the individual cleanliness classes.



Guide values
for the contamination factor e_C

$d_M = \text{mean bearing diameter}$
 $(d + D)/2$

Contamination	Contamination factor e_C			
	$d_M < 100 \text{ mm}$		$d_M \geq 100 \text{ mm}$	
	from	to	from	to
Very high cleanliness: ■ Particle size within the order of magnitude of the lubricant film thickness ■ Laboratory conditions.	1		1	
High cleanliness: ■ Oil filtered through extremely fine filter ■ Sealed, greased bearings.	0,8	0,6	0,9	0,8
Standard cleanliness: ■ Oil filtered through fine filter.	0,6	0,5	0,8	0,6
Slight contamination: ■ Slight contamination of oil.	0,5	0,3	0,6	0,4
Typical contamination: ■ Bearing contaminated by wear debris from other machine elements.	0,3	0,1	0,4	0,2
Heavy contamination: ■ Bearing environment is heavily contaminated ■ Bearing environment inadequately sealed.	0,1	0	0,1	0
Very heavy contamination	0		0	

1.8 Requisite minimum load



In order to prevent damage due to slippage, a minimum radial or axial load must be applied to the bearings ▶44 | 3.



3
 Recommended minimum radial and axial load for rolling bearings

Bearing type	Recommended minimum load
Deep groove ball bearings	$P > C_0/100$
Angular contact ball bearings	$P > C_0/100$
Self-aligning ball bearings	$P > C_0/100$
Cylindrical roller bearings	$P > C_0/60$
Tapered roller bearings	$P > C_0/60$
Barrel roller bearings	$P > C_0/60$
Spherical roller bearings	$P > C_0/100$
Toroidal roller bearings, full complement or with cage	$P > C_0/75$
Needle roller bearings	$P > C_0/60$
Axial deep groove ball bearings	$F_{a\min} = 1000 \cdot A \cdot \left(\frac{n_{\max}}{1000}\right)^2$
Axial cylindrical roller bearings ¹⁾	$F_{a\min} = 0,0005 \cdot C_{0a} + k_a \left(\frac{C_{0a} \cdot n}{10^8}\right)^2$
Axial needle roller bearings	$F_{a\min} = 0,0005 \cdot C_{0a} + 3 \cdot \left(\frac{C_{0a} \cdot n}{10^8}\right)^2$
Axial spherical roller bearings ²⁾	$F_{a\min} = 0,0005 \cdot C_{0a} + k_a \left(\frac{C_{0a} \cdot n}{10^8}\right)^2$

¹⁾ Factor k_a ▶44 | 4

²⁾ Factor k_a ▶44 | 5



4
 Factor k_a
 for axial cylindrical roller bearings

Series	Factor k_a
K811	1,4
K812	0,9
K893	0,7
K894	0,5



5
 Factor k_a
 for axial spherical roller bearings

Series	Factor k_a
292...E	0,6
293...E1(E)	0,9
294...E1(E)	0,7



1.9 Equivalent operating values

Equivalent operating values for non-constant loads and speeds

The rating life equations assume a constant bearing load P and constant bearing speed n . If the load and speed are not constant, equivalent operating values can be determined that induce the same fatigue as the actual loading conditions.



The operating values calculated here already take account of the life adjustment factors a_{ISO} . They must not be applied again when calculating the adjusted rating life.

Variable load and speed

If the load and speed vary over a time period T , the speed n and the equivalent bearing load P ▶45| f12 and ▶45| f13 are calculated as follows. If only a basic rating life is to be calculated, the terms $1/a_{ISO}$ can be omitted from the equations ▶45| f12 to ▶46| f19.

f12
Equivalent speed

$$n = \frac{1}{T} \int_0^T n(t) \cdot dt$$

f13
Equivalent bearing load

$$P = \sqrt[p]{\frac{\int_0^T \frac{1}{a_{ISO}(t)} \cdot n(t) \cdot F^P(t) \cdot dt}{\int_0^T n(t) \cdot dt}}$$

Variation in steps

If the load and speed vary in steps over a time period T , n and P are calculated as follows ▶45| f14 and ▶45| f15.

f14
Equivalent speed

$$n = \frac{q_1 \cdot n_1 + q_2 \cdot n_2 + \dots + q_z \cdot n_z}{100}$$

f15
Equivalent bearing load

$$P = \sqrt[p]{\frac{\frac{1}{a_{ISO i}} \cdot q_i \cdot n_i \cdot F_i^P + \dots + \frac{1}{a_{ISO z}} \cdot q_z \cdot n_z \cdot F_z^P}{q_i \cdot n_i + \dots + q_z \cdot n_z}}$$

Variable load at constant speed

If the function F describes the variation in the load over a time period T and the speed is constant, P is calculated as follows ▶45| f16.

f16
Equivalent bearing load

$$P = \sqrt[p]{\frac{1}{T} \int_0^T \frac{1}{a_{ISO}(t)} \cdot F^P(t) \cdot dt}}$$

Load varying in steps at constant speed

If the load varies in steps over a time period T and the speed is constant, P is calculated as follows ▶45| f17.

f17
Equivalent bearing load

$$P = \sqrt[p]{\frac{\frac{1}{a_{ISO i}} \cdot q_i \cdot F_i^P + \dots + \frac{1}{a_{ISO z}} \cdot q_z \cdot F_z^P}{100}}$$

Constant load at variable speed

If the speed varies but the load remains constant, the following applies
 ▶ 46 | f18.

f18
 Equivalent speed

$$n = \frac{1}{T} \int_0^T \frac{1}{a_{ISO}(t)} \cdot n(t) \cdot dt$$

Constant load with speed varying in steps

If the speed varies in steps, the following applies ▶ 46 | f19.

f19
 Equivalent speed

$$n = \frac{\frac{1}{a_{ISO i}} \cdot q_i \cdot n_i + \dots + \frac{1}{a_{ISO z}} \cdot q_z \cdot n_z}{100}$$

Swivel motion

The equivalent speed is calculated in accordance with ▶ 46 | f20.
 If the swivel angle is smaller than twice the pitch angle of the rolling elements, there is a risk of false brinelling.



f20
 Equivalent speed

$$n = n_{osc} \cdot \frac{\varphi}{180^\circ}$$

Legend

n	min ⁻¹	Equivalent speed
T	min	Time period under consideration
P	N	Equivalent bearing load
p	-	Life exponent; for roller bearings: p = 10/3 for ball bearings: p = 3
a _{ISO i} , a _{ISO t}	-	Life adjustment factor a _{ISO} for current operating condition
n _i , n(t)	min ⁻¹	Bearing speed for current operating condition
q _i	%	Duration of operating condition as a proportion of the total operating period; q _i = (Δt _i /T) · 100
F _i , F(t)	N	Bearing load during the current operating condition
n _{osc}	min ⁻¹	Frequency of swivel motion
φ	°	Swivel angle ▶ 46 f7.



Swivel motion, swivel angle

Complete swivel motion = 2 · φ_s
 φ_s = swivel angle of the bearing
 φ_a = swivel angle at which every point on the outer raceway is overrolled

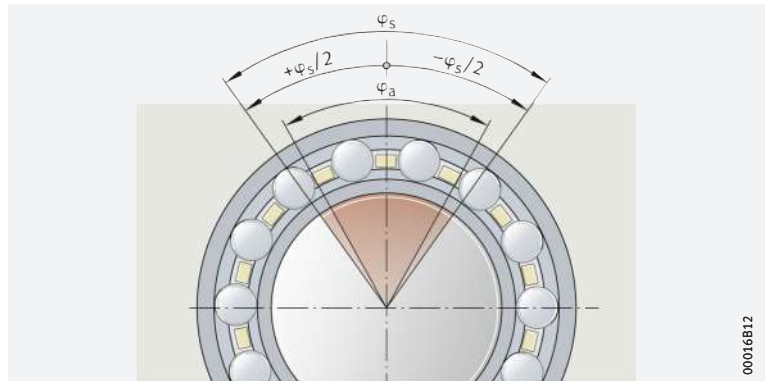

00016B12



1.10 Guide values for dimensioning

Guide values for rating life

The values for the recommended rating life are guide values for normal operating conditions ▶ 47 | 6 to ▶ 51 | 22. In addition, the tables give the operating life values that are usually achieved in practice at various mounting locations.



Do not overspecify the bearings, otherwise it may not be possible to observe the requisite minimum load. Recommended minimum load ▶ 44 | 1.8 and product chapter.

6 Motor vehicles

Mounting location	Recommended rating life h			
	Ball bearings		Roller bearings	
	from	to	from	to
Motorcycles	400	2 000	400	2 400
Passenger car powertrains	500	1 100	500	1 200
Passenger car gearboxes protected against contamination	200	500	200	500
Passenger car wheel bearings	1 400	5 300	1 500	7 000
Light commercial vehicles	2 000	4 000	2 400	5 000
Medium commercial vehicles	2 900	5 300	3 600	7 000
Heavy commercial vehicles	4 000	8 800	5 000	12 000
Buses	2 900	11 000	3 600	16 000
Internal combustion engines	900	4 000	900	5 000

7 Rail vehicles

Mounting location	Operating life Millions of kilometres	
	from	to
Wheelset bearings for freight wagons	0,1	0,1
Urban transport vehicles	1	2
Passenger carriages	2	3
Goods wagons	1	2
Tipper wagons	1	2
Powered units	2	3
Locomotives, external bearings	2	4
Locomotives, internal bearings	2	4
Shunting and industrial locomotives	0,5	1
Gearboxes for rail vehicles	0,5	2

8 Shipbuilding

Mounting location	Recommended rating life h				Operating life h	
	Ball bearings		Roller bearings		from	to
	from	to	from	to		
Marine thrust bearings	–	–	20 000	50 000	30 000	80 000
Marine shaft bearings	–	–	50 000	200 000	30 000	80 000
Large marine gearboxes	14 000	46 000	20 000	75 000	30 000	80 000
Small marine gearboxes	4 000	14 000	5 000	20 000	5 000	20 000
Boat propulsion systems	1 700	7 800	2 000	10 000	2 000	10 000

9
 Agricultural machinery

Mounting location	Recommended rating life h				Operating life h			
	Ball bearings		Roller bearings		from		to	
	from	to	from	to				
Tractors	1 700	4 000	2 000	5 000	5 000	10 000		
Self-propelled machinery	1 700	4 000	2 000	5 000	2 000	6 000		
Seasonal machinery	500	1 700	500	2 000	500	2 000		

10
 Construction machinery

Mounting location	Recommended rating life h				Operating life h			
	Ball bearings		Roller bearings		from		to	
	from	to	from	to				
Dozers, loaders	4 000	7 800	5 000	10 000	5 000	10 000		
Excavators, travelling gear	500	1 700	500	2 000	500	2 000		
Excavators, slewing gear	1 700	4 000	2 000	5 000	2 000	5 000		
Vibratory road rollers, unbalance generators	1 700	4 000	2 000	5 000	5 000	30 000		
Vibrator bodies	500	1 700	500	2 000	500	2 000		

11
 Electric motors

Mounting location	Recommended rating life h				Operating life h			
	Ball bearings		Roller bearings		from		to	
	from	to	from	to				
Electric motors for household appliances	1 700	4 000	–	–	500	1 000		
Series motors	21 000	32 000	35 000	50 000	20 000	30 000		
Large motors	32 000	63 000	50 000	110 000	40 000	50 000		
Wind energy generators	–	–	–	–	100 000	200 000		
Generators	–	–	–	–	40 000	50 000		

continued ▼

11
 Electric motors

Mounting location	Recommended rating life h				Operating life km			
	Ball bearings		Roller bearings		from		to	
	from	to	from	to				
Electric traction motors for	14 000	21 000	20 000	35 000	–			
mainline operation	–	–	–	–	2 000 000	2 500 000		
trams	–	–	–	–	1 000 000	1 000 000		
suburban and underground trains	–	–	–	–	1 500 000	1 500 000		

continued ▲

12
 Rolling mills, steelworks equipment

Mounting location	Recommended rating life h				Operating life h			
	Ball bearings		Roller bearings		from		to	
	from	to	from	to				
Rolling mill frames	500	14 000	500	20 000	2 000	10 000		
Rolling mill gearboxes	14 000	32 000	20 000	50 000	20 000	40 000		
Roller tables	7 800	21 000	10 000	35 000	20 000	40 000		
Centrifugal casting machines	21 000	46 000	35 000	75 000	30 000	60 000		

13
 Machine tools

Mounting location	Recommended rating life h				Operating life h	
	Ball bearings		Roller bearings		from to	
	from	to	from	to		
Headstock spindles, milling spindles	14 000	46 000	20 000	75 000	10 000	30 000
Drilling spindles	14 000	32 000	20 000	50 000	1 000	20 000
External grinding spindles	7 800	21 000	10 000	35 000	10 000	20 000
Hole grinding spindles	–				500	2 000
Workpiece spindles in grinding machines	21 000	63 000	35 000	110 000	20 000	30 000
Machine tool gearboxes	14 000	32 000	20 000	50 000	10 000	20 000
Presses, flywheels	21 000	32 000	35 000	50 000	20 000	30 000
Presses, eccentric shafts	14 000	21 000	20 000	35 000	10 000	20 000
Electric tools and compressed air tools	4 000	14 000	5 000	20 000	100	200

14
 Woodworking machinery

Mounting location	Recommended rating life h				Operating life h	
	Ball bearings		Roller bearings		from to	
	from	to	from	to		
Milling spindles and cutter blocks	14 000	32 000	20 000	50 000	10 000	20 000
Saw frames, main bearings	–	–	35 000	50 000	–	
Saw frames, connecting rod bearings	–	–	10 000	20 000	–	
Circular saws	4 000	14 000	5 000	20 000	10 000	20 000

15
 Gearboxes in general machine building

Mounting location	Recommended rating life h				Operating life h	
	Ball bearings		Roller bearings		from to	
	from	to	from	to		
Universal gearboxes	4 000	14 000	5 000	20 000	5 000	20 000
Geared motors	4 000	14 000	5 000	20 000	5 000	20 000
Large gearboxes, stationary	14 000	46 000	20 000	75 000	20 000	80 000

16
 Conveying equipment

Mounting location	Recommended rating life h				Operating life h	
	Ball bearings		Roller bearings		from	to
	from	to	from	to		
Belt drives, mining	–	–	75 000	150 000	10 000	30 000
Conveyor belt rollers, mining	46 000	63 000	75 000	110 000	10 000	30 000
Conveyor belt rollers, general	7 800	21 000	10 000	35 000	10 000	30 000
Belt drums	–	–	50 000	75 000	10 000	30 000
Bucket wheel excavators, travel drive	7 800	21 000	10 000	35 000	5 000	15 000
Bucket wheel excavators, bucket wheel	–	–	75 000	200 000	30 000	50 000
Bucket wheel excavators, bucket wheel drive	46 000	83 000	75 000	150 000	30 000	50 000
Winding cable sheaves	32 000	46 000	50 000	75 000	50 000	80 000
Sheaves	7 800	21 000	10 000	35 000	8 000	30 000
Tunnel-boring machines: drill head main bearings	–	–	–	–	5 000	10 000

17
 Pumps, fans, compressors

Mounting location	Recommended rating life h				Operating life h	
	Ball bearings		Roller bearings		from	to
	from	to	from	to		
Ventilators, fans	21 000	46 000	35 000	75 000	20 000	100 000
Large fans	32 000	63 000	50 000	110 000	10 000	–
Piston pumps	21 000	46 000	35 000	75 000	20 000	50 000
Centrifugal pumps	14 000	46 000	20 000	75 000	20 000	50 000
Hydraulic axial and radial piston engines	500	7 800	500	10 000	1 000	20 000
Gear pumps	500	7 800	500	10 000	1 000	20 000
Compressors	4 000	21 000	5 000	35 000	30 000	80 000

18
 Centrifuges, stirrers

Mounting location	Recommended rating life h				Operating life h	
	Ball bearings		Roller bearings		from	to
	from	to	from	to		
Centrifuges	7 800	14 000	10 000	20 000	40 000	60 000
Large stirrers	21 000	32 000	35 000	50 000	40 000	50 000

19
 Textile machinery

Mounting location	Recommended rating life h				Operating life h	
	Ball bearings		Roller bearings		from	to
	from	to	from	to		
Spinning machines, spinning spindles	21 000	46 000	35 000	75 000	10 000	50 000
Weaving and knitting machines	14 000	32 000	20 000	50 000		



20
Plastics processing

Mounting location	Recommended rating life h				Operating life h	
	Ball bearings		Roller bearings		from	to
	from	to	from	to		
Plastics worm extruders	14 000	21 000	20 000	35 000	20 000	100 000
Rubber and plastics calenders	21 000	46 000	35 000	75 000		

21
Crushers, mills, screens

Mounting location	Recommended rating life h				Operating life h	
	Ball bearings		Roller bearings		from	to
	from	to	from	to		
Jaw crushers	–	–	20 000	35 000	25 000	40 000
Gyratory crushers, roll crushers	–	–	20 000	35 000		
Rigid hammer mills, hammer mills, impact crushers	–	–	50 000	110 000	40 000	40 000
Tube mills	–	–	50 000	100 000	100 000	100 000
Vibration grinding mills	–	–	5 000	20 000	30 000	60 000
Grinding track mills	–	–	50 000	110 000	60 000	100 000
Vibrating screens	–	–	10 000	20 000	10 000	30 000
Briquette presses	–	–	35 000	50 000	40 000	40 000
Rotary kiln radial support rollers	–	–	50 000	110 000	100 000	–
Roller presses	–	–	–	–	40 000	40 000

22
Paper and printing machinery

Mounting location	Recommended rating life h				Operating life h	
	Ball bearings		Roller bearings		from	to
	from	to	from	to		
Paper machinery, wet section	–	–	110 000	150 000	50 000	100 000
Paper machinery, dry section	–	–	150 000	250 000	–	
Guide rolls					50 000	120 000
Dryer rolls					50 000	150 000
M.G. cylinders					50 000	200 000
Paper machinery, refiners	–	–	80 000	120 000	50 000	100 000
Paper machinery, calenders	–	–	80 000	110 000	50 000	100 000
Printing machinery	32 000	46 000	50 000	75 000	30 000	60 000

1.11 Static load carrying capacity

 *Plastic deformation limits the static load carrying capacity*

If high, static or shock loads occur, the raceways and rolling elements may undergo plastic deformation. This deformation limits the static load carrying capacity of the rolling bearing with respect to the permissible noise level during operation of the bearing.

 *Basic static load rating*

If a rolling bearing operates with only infrequent rotary motion or completely without rotary motion, its size is determined in accordance with the basic static load rating C_0 .

In accordance with DIN ISO 76, this is:

- a constant radial load C_{0r} for radial bearings
- a constant, concentrically acting axial load C_{0a} for axial bearings.

The basic static load rating C_0 is that load under which the Hertzian pressure at the most heavily loaded point between the rolling elements and raceways reaches the following values:

- for roller bearings, 4 000 N/mm²
- for ball bearings, 4 200 N/mm²
- for self-aligning ball bearings, 4 600 N/mm².

Under normal contact conditions, this load causes a permanent deformation at the contact points of approx. 1/10 000 of the rolling element diameter.

Static load safety factor





In addition to dimensioning on the basis of the fatigue life, it is advisable to check the static load safety factor. Guide values and shock loads occurring during operation in accordance with ► 52 |  23 must be taken into consideration.

 **21**
 Static load safety factor

$$S_0 = \frac{C_0}{P_0}$$

Legend

S_0	–	Static load safety factor; guide values ► 52  23
C_{0r}, C_{0a}	N	Basic radial or axial static load rating; see product tables
P_{0r}, P_{0a}	N	Radial or axial equivalent static bearing load ► 53  22.

Guide values for static load safety factor



Guide values for the requisite static load safety factor S_0 are given in DIN ISO 76:2009-01 and in ► 52 |  23. Guide values for axial spherical roller bearings and high precision bearings: see corresponding product description. For drawn cup needle roller bearings, $S_0 \geq 3$ is necessary.

 **23**
 Static load safety factor S_0 for ball and roller bearings – guide values

Operating conditions and application	Static load safety factor S_0 min.	
	Ball bearings	Roller bearings
Low-noise, smooth running, free from vibrations, high rotational accuracy	2	3
Normal, smooth running, free from vibrations, normal rotational accuracy	1	1,5
Pronounced shock loading ¹⁾	1,5	3

¹⁾ If the order of magnitude of the shock loading is not known, the values used for S_0 should be at least 1,5. If the order of magnitude of the shock loading is known precisely, lower values are possible.



1.12 Equivalent static bearing load

The equivalent static load P_0 is a calculated value. It corresponds to a radial load in radial bearings and a concentric axial load in axial bearings.

P_0 induces the same load at the centre point of the most heavily loaded contact point between the rolling element and raceway as the combined load occurring in practice.

f122
Equivalent static bearing load

Legend

$$P_0 = X_0 \cdot F_r + Y_0 \cdot F_a$$

P_0	N	Equivalent static bearing load
X_0	N	Radial load factor; see product tables or product description
F_r, F_a	N	Largest radial or axial load present
Y_0	N	Axial load factor; see product tables or product description.



The calculation cannot be applied to radial needle roller bearings, axial needle roller bearings and axial cylindrical roller bearings. Combined loads are not permissible with these bearings.

In the case of radial needle roller bearings and all radial cylindrical roller bearings:

$$P_0 = F_{0r}$$

For axial needle roller bearings and axial cylindrical roller bearings:

$$P_0 = F_{0a}$$

1.13 Operating life



The operating life is defined as the life actually achieved by the bearing. It may differ significantly from the calculated life.

Possible factors
influencing the operating life

This may be due to wear or fatigue as a result of:

- deviating operating data
- misalignments between the shaft and housing
- insufficient or excessive operating clearance
- contamination
- insufficient lubrication
- excessive operating temperature
- oscillating bearing movement with very small swivel angles (false brinelling)
- high vibration and false brinelling
- very high shock loads (static overloading)
- prior damage during mounting.

The operating life cannot
be calculated

Due to the wide variety of possible installation and operating conditions, it is not possible to precisely predetermine the operating life. The most reliable way of arriving at a close estimate is by comparison with similar applications.

2 Rigidity

Roller bearings are more rigid than ball bearings

The rigidity of a rolling bearing is dependent on the bearing type, size and operating clearance. The rigidity increases with the number of rolling elements supporting the load. Due to the line contact between the rolling elements and raceways, it is higher in roller bearings than in ball bearings. **► 54 | 1** shows typical characteristic curves for the radial deflection of various bearings with the same bore diameter.

1
 Radial deflection of various radial bearings of bore diameter $d = 50 \text{ mm}$

δ_r = radial deflection
 F_r = radial load

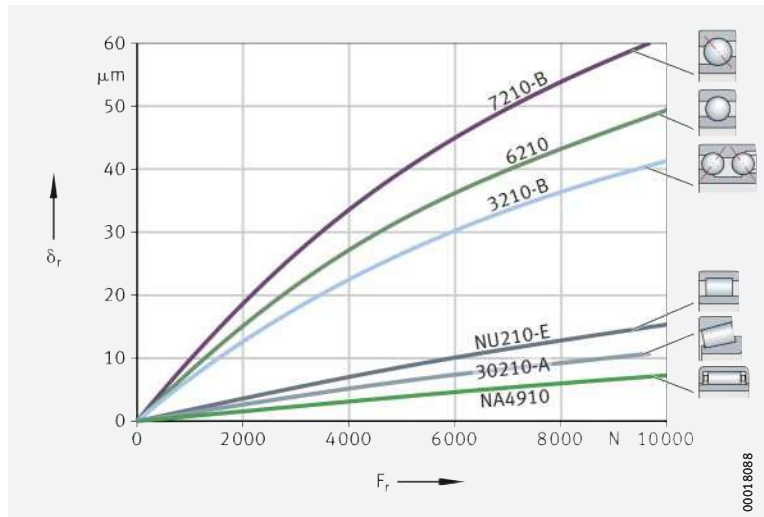

2.1 Calculation of the radial or axial displacement

Progressive deflection rate

Rolling bearings have a progressive deflection rate. The displacement values for needle and cylindrical roller bearings can be determined using approximation equations **► 54 | 1** and **► 54 | 2**.



The equations are valid for bearings without misalignment and with a rigid surrounding structure. In axial bearings, a concentrically acting load is assumed.

1
 Radial displacement

$$\delta_r = \frac{1}{c_s} \cdot F_r^{0,84} + \frac{s}{2}$$

2
 Axial displacement

$$\delta_a = \frac{1}{c_s} \cdot \left[(F_{aV} + F_a)^{0,84} - F_{aV}^{0,84} \right]$$

3
 Rigidity parameter

$$c_s = K_c \cdot d^{0,65}$$

Legend

c_s	$\text{N}^{0,84}/\mu\text{m}$	Rigidity parameter
d	mm	Bearing bore diameter
δ_r	μm	Radial displacement between shaft axis and centre of bore ► 55 2
δ_a	μm	Axial displacement between shaft locating washer and housing locating washer ► 55 3
s	μm	Radial operating clearance of fitted, unloaded bearing
F_r	N	Radial load
F_a	N	Axial load
F_{aV}	N	Axial preload force
K_c	-	Factor for determining the rigidity parameter ► 55 1 .



2

Radial cylindrical roller bearings, radial displacement

δ_r = radial displacement
 F_r = radial load

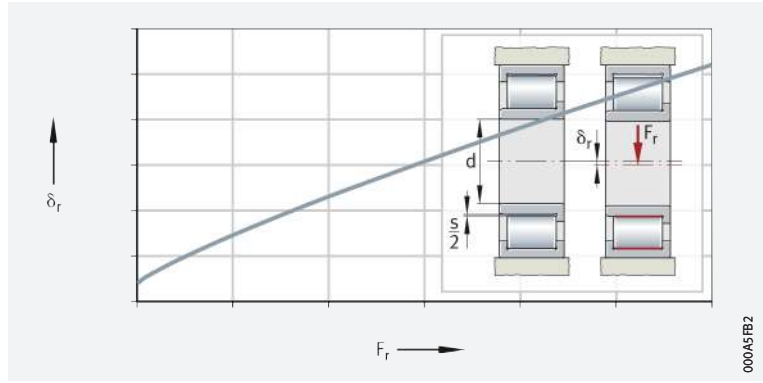

000A5FB2

3

Axial cylindrical roller bearing, axial displacement

δ_a = axial displacement
 F_a = axial load
 F_{aV} = axial preload force

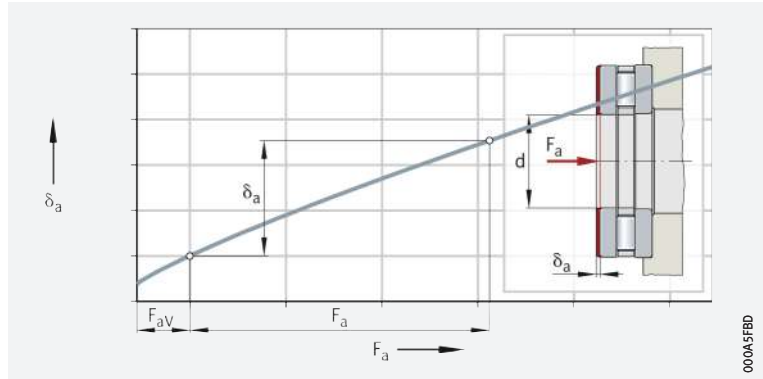

000A5FB3

1
Factor K_c

Bearing series	Factor K_c	Series	Factor K_c
SL1818	12,8	K811, 811, K812, 812	36,7
SL1829, SL1830, SL1923	16	K893, 893, K894, 894	59,7
SL1850, SL0148, SL0248, SL0249	29,2	NJ2..-E	11,1
NA48	24,9	NJ3..-E	11,3
NA49	23,5	NJ22..-E	15,4
NA69	37,3	NJ23..-E	16,9
NKIS	21,3	NU10	9,5
NKI	$4,4 \cdot B^{0,8}/d^{0,2}$	NU19	11,3
HK, BK	$4,2 \cdot C^{0,8}/d^{0,2}$	NN30..-AS-K	18,6



This simplified calculation cannot be applied to other bearing types. The displacement and rigidity at the operating point can be determined using the calculation program BEARINX-online.

3 Friction and increases in temperature

Frictional components

The friction in a rolling bearing is made up of several components **► 56** | **1**. Due to the large number of influencing factors, such as dynamics in speed and load, tilting and skewing resulting from installation, actual frictional torques and frictional power may deviate significantly from the calculated values.



If the frictional torque is an important design criterion, please consult Schaeffler.



The calculation module BEARINX-online Easy Friction, which is available from Schaeffler free of charge, can be used to calculate and analyse the frictional torque.

1 Frictional component and influencing factor

Frictional component	Influencing factor
Rolling friction	Magnitude of load
Sliding friction of rolling elements Sliding friction of cage	Magnitude and direction of load Speed and lubrication conditions, running-in condition
Fluid friction (flow resistance)	Type and speed Type, quantity and operating viscosity of lubricant
Seal friction	Type and preload of seal

Influencing factors on idling friction

The idling friction is dependent on the lubricant quantity, speed, operating viscosity of the lubricant, seals and the running-in condition of the bearing.

3.1 Heat dissipation

Friction is converted into heat. This must be dissipated from the bearing. The equilibrium between the frictional power and heat dissipation allows calculation of the thermally safe operating speed n_{θ} **► 65** | 4.3.

Lubricant

Lubricating oil dissipates a portion of the heat. Recirculating oil lubrication with additional cooling is particularly effective. Grease does not give dissipation of heat.

Shaft and housing

Heat dissipation via the shaft and housing is dependent on the temperature difference between the bearing and the surrounding structure. Any additional adjacent sources of heat or thermal radiation must be taken into consideration.

3.2 Determining the friction values

The speed and load must also be known. The type of lubrication, lubrication method and viscosity of the lubricant at operating temperature are further important factors in calculation.

1 Total frictional torque

$$M_R = M_0 + M_1$$

2 Frictional power

$$N_R = M_R \cdot \frac{n}{9550}$$



For $v \cdot n \geq 2\,000$:

f13
Frictional torque
as a function of speed

$$M_0 = f_0 \cdot (v \cdot n)^{2/3} \cdot d_M^3 \cdot 10^{-7}$$

For $v \cdot n < 2\,000$:

f14
Frictional torque
as a function of speed

$$M_0 = f_0 \cdot 160 \cdot d_M^3 \cdot 10^{-7}$$

Frictional torque as a function of load for needle roller and cylindrical roller bearings:

f15
Frictional torque
as a function of load

$$M_1 = f_1 \cdot F \cdot d_M$$

Frictional torque as a function of load for ball bearings, tapered roller bearings and spherical roller bearings:

f16
Frictional torque
as a function of load

$$M_1 = f_1 \cdot P_1 \cdot d_M$$

Legend

M_R	Nmm	Total frictional torque
M_0	Nmm	Frictional torque as a function of speed
M_1	Nmm	Frictional torque as a function of load
N_R	W	Frictional power
n	min ⁻¹	Operating speed
f_0	–	Bearing factor for frictional torque as a function of speed ► 58 1 and ► 58 2 to ► 61 14
f_1	–	Bearing factor for frictional torque as a function of load ► 58 2 to ► 61 14
ν	mm ² /s	Kinematic viscosity of lubricant at operating temperature. In the case of grease, the decisive factor is the viscosity of the base oil at operating temperature
F_r, F_a	N	Radial load for radial bearings, axial load for axial bearings
P_1	N	Decisive load for frictional torque. For ball bearings, tapered roller bearings and spherical roller bearings ► 61 3.3
d_M	mm	Mean bearing diameter $(d + D)/2$.

Bearing factors



The bearing factors f_0 and f_1 are mean values from series of tests and correspond to the data in accordance with ISO 15312. They are valid for bearings after running-in and with uniform distribution of lubricant. In the freshly greased state, the bearing factor f_0 can be two to five times higher.



If oil bath lubrication is used, the oil level must reach the centre of the lowest rolling element. If the oil level is higher, f_0 may be up to three times the value given in the table ➤ 58 | 1.

1

Increase in the bearing factor f_0 , as a function of the oil level

h = oil level

d_M = mean bearing diameter $(d+D)/2$

① Increase in the bearing factor f_0

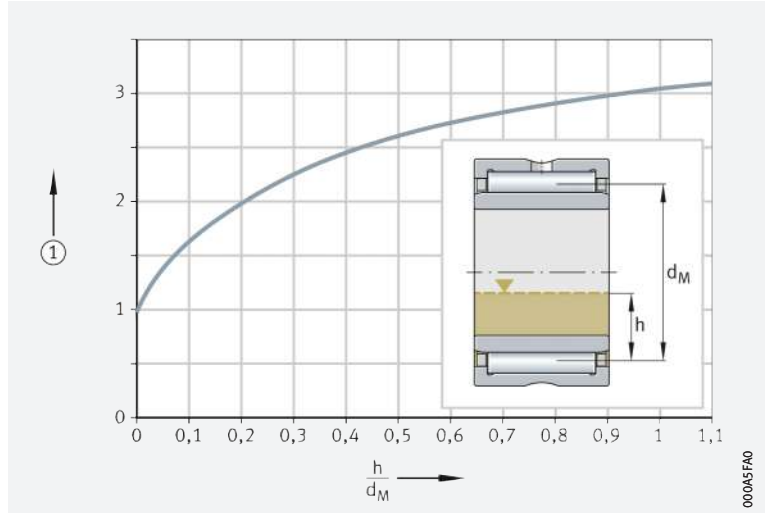

2

Bearing factor f_0, f_1 for needle roller bearings, drawn cup needle roller bearings with open ends or with closed end, needle roller and cage assemblies

Series	Bearing factor f_0		Bearing factor f_1
	Grease and oil mist	Oil bath and recirculating oil	
NA48	3	5	0,0005
NA49	4	5,5	
RNA48	3	5	
RNA49	4	5,5	
NA69	7	10	
RNA69			
NKI, NK, NKIS, NKS, NAO, RNO, RNAO, K	$(12 \cdot B)/(33 + d)$	$(18 \cdot B)/(33 + d)$	
NK...-TW, NKI...-TW, NK...-D	$(10 \cdot B)/(33 + d)$	$(15 \cdot B)/(33 + d)$	
HK, BK	$(24 \cdot B)/(33 + d)$	$(36 \cdot B)/(33 + d)$	
HN	$(30 \cdot B)/(33 + d)$	$(45 \cdot B)/(33 + d)$	

3

Bearing factor f_0, f_1 for cylindrical roller bearings, full complement

Series	Bearing factor f_0		Bearing factor f_1
	Grease and oil mist	Oil bath and recirculating oil	
SL1818	3	5	0,00055
SL1829	4	6	
SL1830	5	7	
SL1822	5	8	
SL0148, SL0248	6	9	
SL0149, SL0249	7	11	
SL1923	8	12	
SL1850	9	13	



4
 Bearing factor f_0, f_1
 for cylindrical roller bearings with
 cage

Series	Bearing factor f_0		Bearing factor f_1
	Grease and oil mist	Oil bath and recirculating oil	
LSL1923	1	3,7	0,00020
ZSL1923	1	3,8	0,00025
NU2..-E, NNU41	1,3	2	0,00030
NU3..-E			0,00035
NU4			0,00040
NU10, NU19			0,00020
NU22..-E			2
NU23..-E	2,7	4	0,00040
NU30..-E, NN30..-E	1,7	2,5	0,00040

5
 Bearing factor f_0, f_1
 for axial roller bearings

Series	Bearing factor f_0		Bearing factor f_1
	Grease and oil mist	Oil bath and recirculating oil	
AXK, AXW	3	4	0,0015
810, K810, 811, K811	2	3	
812, K812			
893, K893			
894, K894			

6
 Bearing factor f_0, f_1
 for combined bearings

Series	Bearing factor f_0		Bearing factor f_1
	Grease and oil mist	Oil bath and recirculating oil	
ZARN, ZARF	3	4	0,0015
NKXR	2	3	
NX, NKX	2	3	$0,001 \cdot (P_0/C_0)^{0,33}$
ZKLN, ZKLF	4	6	
NKIA, NKIB	3	5	0,0005

7
 Bearing factor f_0, f_1
 for tapered roller bearings

Series	Bearing factor f_0		Bearing factor f_1
	Grease and oil mist	Oil bath and recirculating oil	
302, 303, 329, 320, 330, JK0S, T4CB, T4DB, T7FC	2	3	0,0004
313, 322, 323, 331, 332, T2EE, T2ED, T5ED	3	4,5	

8
 Bearing factor f_0, f_1
 for axial and
 radial spherical roller bearings

Series	Bearing factor f_0		Bearing factor f_1
	Grease and oil mist	Oil bath and recirculating oil	
213..-E1	2,3	3,5	$0,0005 \cdot (P_0/C_0)^{0,33}$
222..-E1		4	
223	3	4,5	$0,0008 \cdot (P_0/C_0)^{0,33}$
238, 239, 230			$0,00075 \cdot (P_0/C_0)^{0,5}$
231	3,7	5,5	$0,0012 \cdot (P_0/C_0)^{0,5}$
232	4	6	$0,0016 \cdot (P_0/C_0)^{0,5}$
240	4,3	6,5	$0,0012 \cdot (P_0/C_0)^{0,5}$
248, 249, 241	4,7	7	$0,0022 \cdot (P_0/C_0)^{0,5}$
292..-E	1,7	2,5	0,00023
293..-E	2	3	0,00030
294..-E	2,2	3,3	0,00033

9
 Bearing factor f_0, f_1
 for toroidal roller bearings

Series	Bearing factor f_0		Bearing factor f_1
	Grease and oil mist	Oil bath and recirculating oil	
C22..-K	3,7	5,5	$0,0012 \cdot (P_0/C_0)^{0,5}$
C22..-V	4	6	
C23..-K	3,8	5,7	
C23..-V	4,3	6,5	
C30..-K	3,3	5	
C30..-V, C31..-V	4	6	
C31..-K	3,7	5,5	
C32..-K	3,8	5,7	$0,0016 \cdot (P_0/C_0)^{0,5}$
C39..-K	3,3	5	$0,0014 \cdot (P_0/C_0)^{0,5}$
C40..-K, C41..-K	5	7,5	$0,0018 \cdot (P_0/C_0)^{0,5}$
C40..-V, C41..-V	6	9	

10
 Bearing factor f_0, f_1
 for deep groove ball bearings

Series	Bearing factor f_0		Bearing factor f_1
	Grease and oil mist	Oil bath and recirculating oil	
618	1,1	1,7	$0,0005 \cdot (P_0/C_0)^{0,5}$
160, 60, 619	1,1	1,7	$0,0007 \cdot (P_0/C_0)^{0,5}$
622, 623	1,1	1,7	$0,0009 \cdot (P_0/C_0)^{0,5}$
62	1,3	2	
63, 630, 64	1,5	2,3	$0,0006 \cdot (P_0/C_0)^{0,5}$
60..-C	1,1	1,5	
62..-C	1,3	1,7	
63..-C	1,5	2	$0,0007 \cdot (P_0/C_0)^{0,5}$
42..-B	2,3	3,5	
43..-B	4	6	$0,0010 \cdot (P_0/C_0)^{0,5}$

11
 Bearing factor f_0, f_1
 for angular contact ball bearings

Series	Bearing factor f_0		Bearing factor f_1
	Grease and oil mist	Oil bath and recirculating oil	
708, 719, 70..-B	1,3	2	$0,001 \cdot (P_0/C_0)^{0,33}$
718..-B			
72..-B			
73..-B	2	3	
74..-B	2,5	4	
30..-B	2,3	3,5	
32..-B			
38..-B			
33..-B	4	6	
32..-BD	2	3	
33..-BD	3,5	5	

12
 Bearing factor f_0, f_1
 for self-aligning ball bearings

Series	Bearing factor f_0		Bearing factor f_1
	Grease and oil mist	Oil bath and recirculating oil	
10, 112	1,7	2	$0,0003 \cdot (P_0/C_0)^{0,4}$
12	1,7	2,5	
13	2,3	3,5	
22	2	3	
23	2,7	4	



13
 Bearing factor f_0, f_1
 for four point contact bearings

Series	Bearing factor f_0		Bearing factor f_1
	Grease and oil mist	Oil bath and recirculating oil	
QJ2	1,3	2	$0,001 \cdot (P_0/C_0)^{0,33}$
QJ3	2	3	
QJ10	1,3	2	

14
 Bearing factor f_0, f_1
 for axial deep groove ball bearings

Series	Bearing factor f_0		Bearing factor f_1
	Grease and oil mist	Oil bath and recirculating oil	
511, 512, 513, 514, 532, 533, 534	1	1,5	$0,0012 \cdot (F_a/C_0)^{0,33}$
522, 523, 524, 542, 543, 544	1,3	2	

3.3 Load P_1 for ball bearings, tapered roller bearings, spherical roller bearings

P_1 for single bearings and bearing pairs

The calculation equations for load value P_1 , which is the decisive load for frictional torque as a function of load M_1 , are dependent on the bearing type ▶ 61 | 15. If $P_1 \leq F_r$, then $P_1 = F_r$.

15
 Decisive load P_1

Bearing type	Decisive load P_1	
	for single bearings	for bearing pairs
Deep groove ball bearings	$3,3 \cdot F_a - 0,1 \cdot F_r$	–
Angular contact ball bearings, single row	$F_a - 0,1 \cdot F_r$	$1,4 \cdot F_a - 0,1 \cdot F_r$
Angular contact ball bearings, double row	$1,4 \cdot F_a - 0,1 \cdot F_r$	–
Four point contact bearings	$1,5 \cdot F_a + 3,6 \cdot F_r$	–
Tapered roller bearings	$2 \cdot Y \cdot F_a$ or F_r use the larger value	$1,21 \cdot Y \cdot F_a$ or F_r use the larger value
Spherical roller bearings	$1,6 \cdot F_a / e$ if $F_a / F_r > e$ $F_r \cdot \{1 + 0,6 \cdot [F_a / (e \cdot F_r)]^3\}$ if $F_a / F_r \leq e$	
Cylindrical roller bearings	F_r , the frictional component of axial load F_a must be taken into account using M_2	

3.4 Frictional torque for axially loaded radial cylindrical roller bearings

$M_2 =$ frictional torque as a function of axial load

In radial cylindrical roller bearings under axial load, sliding friction between the end faces of the rolling elements and the ribs on the rings leads to an additional frictional torque M_2 . The total frictional torque M_R is calculated in accordance with [▶62|f17](#), the frictional torque as a function of the axial load M_2 is calculated in accordance with [▶62|f18](#).

[f17](#)
Total frictional torque

$$M_R = M_0 + M_1 + M_2$$

Legend

M_R	Nmm	Total frictional torque for axially loaded cylindrical roller bearings
M_0	Nmm	Frictional torque as a function of speed
M_1	Nmm	Frictional torque as a function of radial load
M_2	Nmm	Frictional torque as a function of axial load ▶62 f18 .

[f18](#)
Frictional torque as a function of axial load

$$M_2 = f_2 \cdot F_a \cdot d_M$$

Legend

f_2	-	Bearing factor as a function of the bearing series and of operating parameter $v \cdot n \cdot d_M$ ▶63 q2 and ▶63 q3
F_a	N	Axial dynamic bearing load
d_M	mm	Mean bearing diameter $(d + D)/2$.

Higher axial load carrying capacity and lower axial frictional torque in bearings of TB design

Bearings in TB design

In the case of bearings of TB design (rollers with a toroidal roller end), the axial load carrying capacity was significantly improved through the use of new calculation and manufacturing methods. Optimum contact conditions between the roller and rib are ensured by means of a special curvature of the roller end faces. As a result, axial surface pressures on the rib are significantly reduced and a lubricant film with improved load carrying capacity is achieved. Under normal operating conditions, wear and fatigue at the rib contact running and roller end faces is completely eliminated. In addition, axial frictional torque is reduced by up to 50%. The bearing temperature during operation is therefore significantly lower.

Bearing factor k_B

The bearing factor k_B in the equations takes into consideration the size and thus the load carrying capacity of the hydrodynamic contacts at the bearing ribs [▶62|t16](#).

[t16](#)
Bearing factor k_B

Series	Factor k_B
SL1818, SL0148	4,5
SL1829, SL0149	11
SL1830, SL1850	17
SL1822	20
LSL1923, ZSL1923	28
SL1923	30
NJ2..-E, NJ22..-E, NUP2..-E, NUP22..-E	15
NJ3..-E, NJ23..-E, NUP3..-E, NUP23..-E	20
NJ4	22



Bearing factor f_2 for cylindrical roller bearings



The bearing factor f_2 can vary significantly. The values in the diagrams are valid for recirculating oil lubrication with an adequate quantity of oil
 ▶ 63 | 2 and ▶ 63 | 3; the curves should not be extrapolated.

f_2 as a function of operating parameter and series

▶ 63 | 2 gives the values for bearings without toroidal end face,
 ▶ 63 | 3 gives the factors for cylindrical roller bearings with toroidal end face (TB design).



Radial cylindrical roller bearing in standard design, bearing factor f_2 as a function of the operating parameter $\nu \cdot n \cdot d_M$

- f_2 = bearing factor
- ν = operating viscosity
- n = operating speed
- d_M = mean bearing diameter
- $\nu \cdot n \cdot d_M$ = operating parameter
- F_a = axial dynamic bearing load
- A = bearing parameter

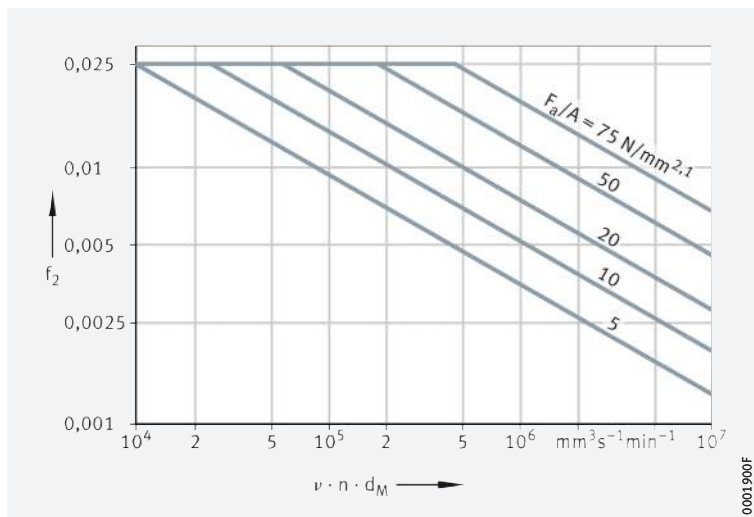

Radial cylindrical roller bearing in TB design, bearing factor f_2 as a function of the operating parameter $\nu \cdot n \cdot d_M$

- f_2 = bearing factor
- ν = operating viscosity
- n = operating speed
- d_M = mean bearing diameter
- $\nu \cdot n \cdot d_M$ = operating parameter
- F_a = axial dynamic bearing load
- A = bearing parameter

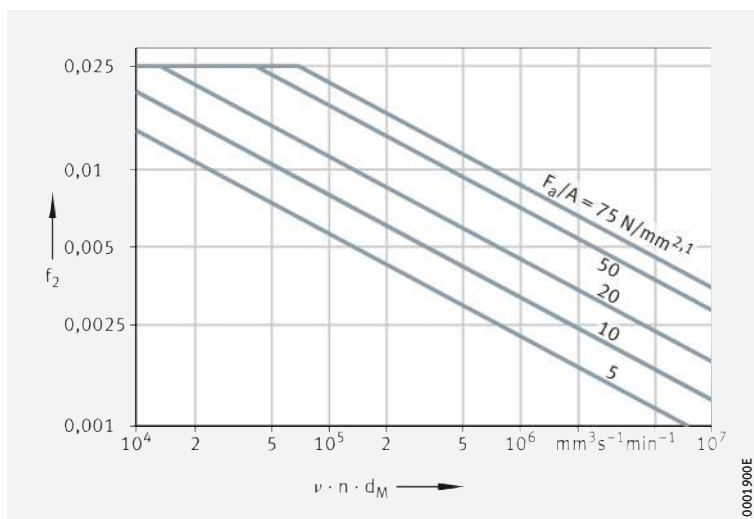

Bearing parameter A for calculating M_2

In order that the bearing factor f_2 can be determined for the calculation of M_2 in ▶ 63 | 2 and ▶ 63 | 3, bearing parameter A must be obtained in accordance with ▶ 63 | 9.



Bearing parameter

$$A = k_B \cdot 10^{-3} \cdot d_M^{2,1}$$

Legend

A	–	Bearing parameter
k_B	–	Bearing factor as a function of the bearing series ▶ 62 16
d_M	mm	Mean bearing diameter $(d + D)/2$.

4 Speeds



The calculation of reference speeds is standardised in ISO 15312. The stated reference speeds have been calculated in accordance with this standard.

4.1 Limiting speed

The limiting speed n_G is based on practical experience and takes account of additional criteria such as smooth running, sealing function and centrifugal forces.



The limiting speeds indicated in the product tables must not be exceeded even under favourable operating conditions without prior consultation with Schaeffler.

4.2 Thermal speed rating

$n_{\vartheta r}$ is used to calculate n_{ϑ}

The thermal speed rating $n_{\vartheta r}$ is used as an ancillary value when calculating the thermally safe operating speed n_{ϑ} . This is the speed at which, under defined reference conditions, a bearing operating temperature of +70 °C is achieved.

The thermal speed rating is not a speed limit for the application of a bearing. It is primarily for the purpose of comparing the speed suitability of different bearing types under defined reference conditions.

A speed limit taking account of the thermal balance can be calculated using the thermally safe operating speed.

Reference conditions

The reference conditions are based on the normal operating conditions of the most significant bearing types and sizes.



They are defined as follows in ISO 15312:

- mean ambient temperature $\vartheta_{Ar} = +20$ °C
- mean bearing temperature at the outer ring $\vartheta_r = +70$ °C
- load on radial bearings $P_1 = 0,05 \cdot C_{0r}$
- load on axial bearings $P_1 = 0,02 \cdot C_{0a}$
- heat dissipation via the bearing seating surfaces
 ➤ 64 | f1 to ➤ 64 | f4:

for radial bearings, bearing seat $A_r \leq 50\,000$ mm² ➤ 64 | f1:

f1
Heat flow density

$$q_r = 0,016 \text{ W/mm}^2$$

for radial bearings, bearing seat $A_r > 50\,000$ mm² ➤ 64 | f2:

f2
Heat flow density

$$q_r = 0,016 \cdot \left(\frac{A_r}{50\,000} \right)^{-0,34} \text{ W/mm}^2$$

for axial bearings, bearing seat $A_r \leq 50\,000$ mm² ➤ 64 | f3:

f3
Heat flow density

$$q_r = 0,020 \text{ W/mm}^2$$

for axial bearings, bearing seat $A_r > 50\,000$ mm² ➤ 64 | f4:

f4
Heat flow density

$$q_r = 0,020 \cdot \left(\frac{A_r}{50\,000} \right)^{-0,16} \text{ W/mm}^2$$



The following lubricants and lubrication methods are suitable:

- conventional mineral oils without EP additives and with the following kinematic viscosity ν_r at $\vartheta_r = +70\text{ °C}$,
 - for radial rolling bearings $\nu_r = 12\text{ mm}^2/\text{s}$ (ISO VG 32)
 - for axial rolling bearings $\nu_r = 24\text{ mm}^2/\text{s}$ (ISO VG 68)
- oil bath lubrication with an oil level up to the centre of the lowest rolling element
- lubricant contamination within the permissible values
- grease lubrication of radial bearings using a lithium soap grease with a mineral oil base and no EP additives (base oil viscosity $22\text{ mm}^2/\text{s}$ at $+70\text{ °C}$); grease filling corresponds to 30% of the free bearing cavity.

4.3 Thermally safe operating speed



The thermally safe operating speed n_{ϑ} is calculated in accordance with DIN 732:2010. The basis for the calculation is the heat balance in the bearing, the equilibrium between the frictional power as a function of speed and the heat dissipation as a function of temperature. When conditions are in equilibrium, the bearing temperature is constant.

Preconditions for calculation

The permissible operating temperature determines the thermally safe operating speed n_{ϑ} of the bearing. The preconditions for calculation are correct mounting, normal operating clearance and constant operating conditions.

Calculation not applicable

The calculation method is not valid for:

- sealed bearings with contact seals, since the maximum speed is restricted by the permissible sliding speed at the seal lip
- yoke and stud type track rollers
- aligning needle roller bearings
- axial deep groove and axial angular contact ball bearings.

Limiting speed n_G

The limiting speed n_G must always be observed.

Precondition

In order to calculate the thermally safe operating speed n_{ϑ} at a constant operating temperature ϑ , the frictional power generated and the total dissipated heat flow of the rolling bearing must be in equilibrium ► 65 | f1 5, Parameters ► 68.

f1 5 Equilibrium

$$N_R = \dot{Q}$$

Equilibrium between frictional power and heat flow

The generated frictional power of the rolling bearing is calculated using the total frictional torque ► 65 | f1 6. The total dissipated heat flow \dot{Q} is calculated in accordance with ► 65 | f1 7.

The frictional power is equal to the dissipated heat flow ► 65 | f1 8.

f1 6 Frictional power

$$N_R = M_R \cdot \omega = \left[10^{-7} \cdot f_0 \cdot (\nu \cdot n_{\vartheta})^2 \cdot d_M^3 + f_1 \cdot P_1 \cdot d_M \right] \cdot \frac{\pi \cdot n_{\vartheta}}{30 \cdot 10^3}$$

f1 7 Total dissipated heat flow

$$\dot{Q} = \dot{Q}_S + \dot{Q}_L + \dot{Q}_E$$

f1 8 Equilibrium between frictional power and heat flow

$$\left[10^{-7} \cdot f_0 \cdot (\nu \cdot n_{\vartheta})^2 \cdot d_M^3 + f_1 \cdot P_1 \cdot d_M \right] \cdot \frac{\pi \cdot n_{\vartheta}}{30 \cdot 10^3} = \dot{Q}_S + \dot{Q}_L + \dot{Q}_E$$

Conversion to more manageable form

►65| §8 can only be solved iteratively. The introduction of the lubricant parameter K_L , the load parameter K_P and the speed ratio f_n has made this more manageable ►66| §9.

§9
 Equilibrium in more manageable form

$$K_L \cdot f_n^3 + K_P \cdot f_n = 1$$

Speed ratio f_n

The speed ratio f_n can be calculated by means of iteration or in the normal operating range of $0,01 \leq K_L \leq 10$ and $0,01 \leq K_P \leq 10$ ►66| §10 and ►66| □1.

§10
 Speed ratio

$$f_n = \frac{490,77}{1 + 498,78 \cdot K_L^{0,599} + 852,88 \cdot K_P^{0,963} - 504,5 \cdot K_L^{0,055} \cdot K_P^{0,832}}$$

□1

Speed ratio f_n as a function of lubricant parameter and load parameter

- f_n = speed ratio
- K_L = lubricant parameter
- K_P = load parameter

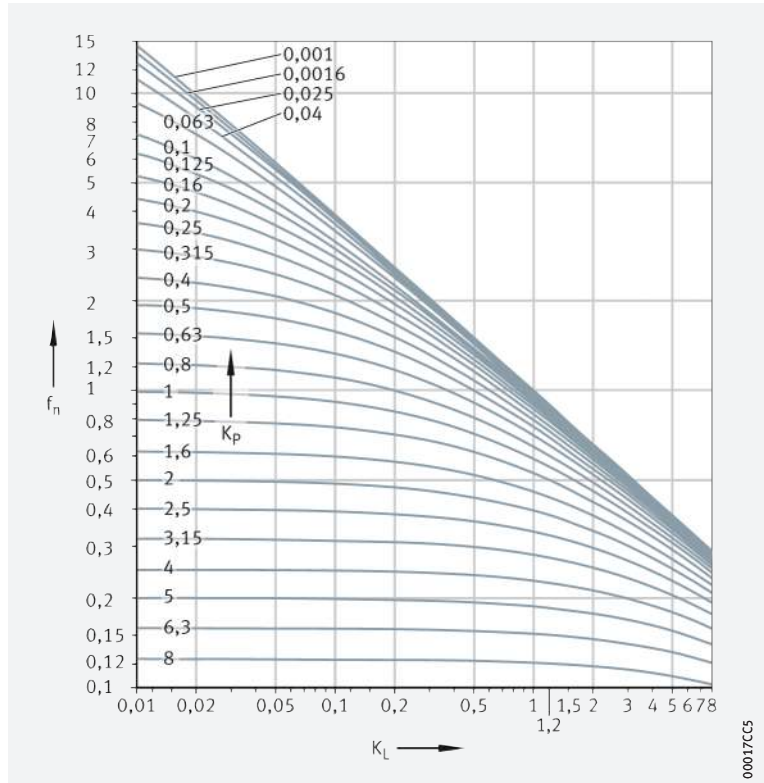



Thermally safe operating speed

The thermally safe operating speed n_{ϑ} is calculated by multiplying the thermal speed rating $n_{\vartheta r}$ by the speed ratio f_n ►67| f11.

f11
Thermally safe operating speed

$$n_{\vartheta} = n_{\vartheta r} \cdot f_n$$

Lubricant parameter K_L

The lubricant parameter K_L is calculated in accordance with ►67| f12.

f12
Lubricant parameter

$$K_L = 10^{-6} \cdot \frac{\pi}{30} \cdot n_{\vartheta r} \cdot \frac{10^{-7} \cdot f_0 \cdot (v \cdot n_{\vartheta r})^2 \cdot d_M^3}{\dot{Q}}$$

Load parameter K_P

The load parameter K_P is calculated in accordance with ►67| f13.

f13
Load parameter

$$K_P = 10^{-6} \cdot \frac{\pi}{30} \cdot n_{\vartheta r} \cdot \frac{f_1 \cdot P_1 \cdot d_M}{\dot{Q}}$$

Heat dissipation via the bearing seating surfaces

Heat dissipation via the bearing seating surfaces is calculated in accordance with ►67| f14.

f14
Heat dissipation via the bearing seating surfaces

$$\dot{Q}_S = k_q \cdot A_S \cdot \Delta\vartheta_A$$

Heat transfer coefficient k_q as a function of the bearing seating surface

k_q = heat transfer coefficient, as a function of the bearing seating surface

A_S = heat-dissipating bearing seating surface

- ① Reference condition for axial bearings
- ② Reference condition for radial bearings

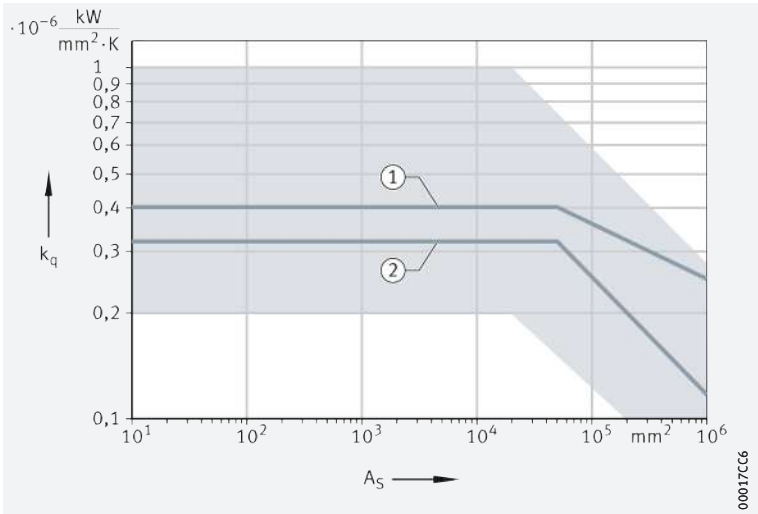



Heat dissipation via the lubricant

Heat dissipation via the lubricant is calculated in accordance with ►67| f15.

f15
Heat dissipation via the lubricant

$$\dot{Q}_L = 0,0286 \frac{\text{kW}}{\text{l/min} \cdot \text{K}} \cdot \dot{V}_L \cdot \Delta\vartheta_L$$

Legend			
N_R		W	Frictional power
\dot{Q}		kW	Total dissipated heat flow
M_R		Nmm	Total frictional torque
f_0		–	Bearing factor for frictional torque as a function of speed
ν		mm ² /s	Kinematic viscosity of the lubricant at operating temperature
n_{θ}		min ⁻¹	Thermally safe operating speed
d_M		mm	Mean bearing diameter $(D + d)/2$
d		mm	Bearing bore diameter
D		mm	Bearing outside diameter
f_1		–	Bearing factor for frictional torque as a function of load
P_1		N	Decisive load: radial load for radial bearings, axial load for axial bearings.
\dot{Q}_S		kW	Heat flow dissipated via the bearing seating surfaces
\dot{Q}_L		kW	Heat flow dissipated by the lubricant
\dot{Q}_E		kW	Heat flow. For heating by external source (+), for cooling by external source (–)
K_L		–	Lubricant parameter
f_n		–	Speed ratio
K_P		–	Load parameter
$n_{\theta r}$		min ⁻¹	Thermal speed rating; see product tables
k_q		10 ⁻⁶ kW/(mm ² · K)	Heat transfer coefficient, as a function of the bearing seating surface  67  2. This is dependent on the housing design and size, the housing material and the installation position. For normal installation, the coefficient of heat transition for bearing seating surfaces up to 25 000 mm ² is between 0,2 · 10 ⁻⁶ kW/(mm ² · K) and 1,0 · 10 ⁻⁶ kW/(mm ² · K)
A_S		mm ²	Heat-dissipating bearing seating surface: In general, $A_S = A_r$
A_r		mm ²	Heat-dissipating bearing seating surface under reference conditions. Radial bearings: $A_r = \pi \cdot B \cdot (D + d)$ Axial bearings: $A_r = \pi/2 \cdot (D^2 - d^2)$ Tapered roller bearings: $A_r = \pi \cdot T \cdot (D + d)$ Axial spherical roller bearings: $A_r = \pi/4 \cdot (D^2 + d_1^2 - D_1^2 - d^2)$
$\Delta\theta_A$		K	Difference between mean bearing temperature and ambient temperature
\dot{V}_L		l/min	Oil flow
$\Delta\theta_L$		K	Difference between oil inlet temperature and oil outlet temperature



5 Noise

5.1 Schaeffler Noise Index

The Schaeffler Noise Index (SGI) has been developed as a new feature for comparing the noise level of different bearing types and series. As a result, a noise evaluation of rolling bearings can now be carried out for the first time.

The SGI value is based on the maximum permissible noise level of a bearing in accordance with internal standards, which is calculated on the basis of ISO 15242. In order that different bearing types and series can be compared, the SGI value is plotted against the basic static load rating C_0 .

This permits direct comparisons between bearings with the same load carrying capacity. The upper limit value is given in each of the diagrams. This means that the average noise level of the bearings is lower than illustrated in the diagram.

! The Schaeffler Noise Index is an additional performance characteristic in the selection of bearings for noise-sensitive applications. The specific suitability of a bearing for an application in terms of installation space, load carrying capacity or speed limit for example, must be checked independently of this.

👁 Until now, the Noise Index has only been available for the main series of radial deep groove ball bearings, radial angular contact ball bearings, tapered roller bearings and cylindrical roller bearings. Additional bearing types and series will be updated and introduced in subsequent publications.

Further information:

■ **medias** ► <https://medias.schaeffler.com>.

Example of Noise Index calculation

If the requisite basic load rating is known for an application, the bearing arrangement can also be designed using the Noise Index as an additional performance characteristic. If the requisite basic static load rating is $C_0 = 20\,300\text{ N}$ for example, various ball bearings are available with a different SGI value ► 69 | 1. As a result, the calculation can be carried out for the bearing application using the smallest SGI value. Bearings of Generation C offer a particular advantage here.



1
 Example: comparison of deep groove ball bearings using the Schaeffler Noise Index

SGI = Schaeffler Noise Index

C_0 = basic static load rating

① = standard series 62

② = series 62...-C (Generation C)

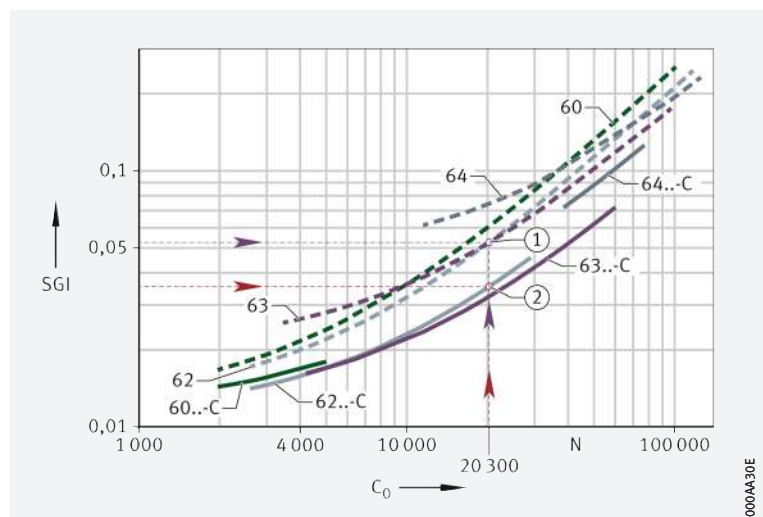

000AA30E

6 Lubrication

6.1 Basic principles



Lubrication and maintenance are important for the reliable operation and long operating life of rolling bearings.

Functions of the lubricant

The lubricant should:

- form a lubricant film on the contact surfaces that is sufficiently capable of supporting loads and thus preventing wear and premature fatigue
- dissipate heat in the case of oil lubrication
- give additional sealing of the bearing, in the case of grease lubrication, against the entry of both solid and fluid contaminants
- dampen running noise
- give protection against corrosion.

Selection of the type of lubrication

Oil or grease lubrication

It should be determined as early as possible in the design process whether bearings should be lubricated using grease or oil.

The following factors are decisive in determining the type of lubrication and quantity of lubricant:

- the operating conditions
- the type and size of the bearing
- the adjacent construction
- the lubricant feed.

Grease lubrication

Criteria for grease lubrication

In the case of grease lubrication, the following criteria must be considered:

- very little design work required
- the sealing action
- the reservoir effect
- long operating life with little maintenance work (lifetime lubrication possible in certain circumstances)
- if relubrication is required, it may be necessary to provide collection areas for old grease and feed ducts
- no heat dissipation by the lubricant
- no rinsing out of wear debris and other particles.

Oil lubrication

Criteria for oil lubrication

In the case of oil lubrication, the following criteria must be considered:

- good lubricant distribution and supply to contact areas
- dissipation of heat possible from the bearing (significant principally at high speeds and/or loads)
- rinsing out of wear debris
- very low friction losses with minimal quantity lubrication
- more work required on feed and sealing.



Under extreme operating conditions (such as very high temperatures, vacuum, aggressive media), it may be possible to use special lubrication methods, such as solid lubricants, in consultation with Schaeffler.



Observe guidelines

Design of lubricant feeds

The feed lines and lubrication holes in the housings and shafts ▶ 71 | 1 and ▶ 71 | 2

- should lead directly to the lubrication hole in the rolling bearing
- should be as short as possible.



A separate feed must be provided for each bearing.

Ensure that the feed lines are filled ▶ 71 | 1; the feed line should be bled if necessary. Follow the instructions provided by the lubrication device manufacturer.

1 Lubricant feed lines

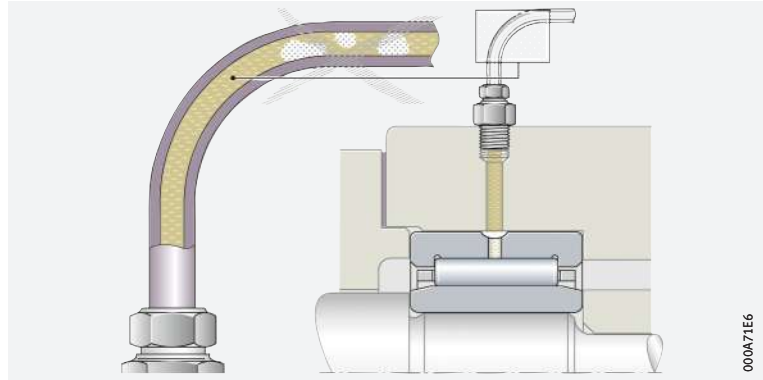

000A71E6

2 Arrangement of feed lines to more than one bearing on a shaft

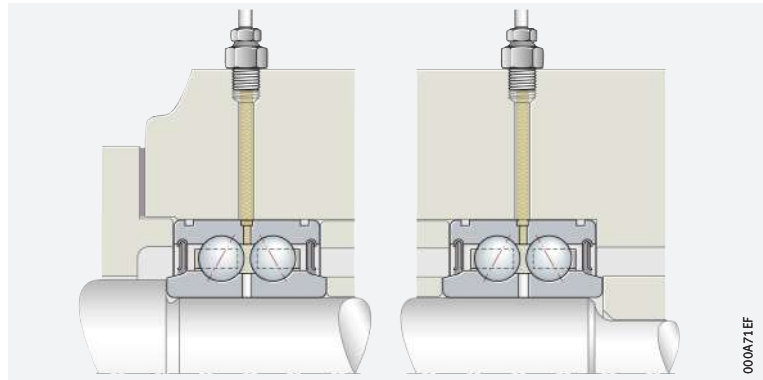

000A71EF

Further information



Comprehensive information on the lubrication of rolling bearings is contained in Technical Product Information ▶ TPI 176. This publication can be requested from Schaeffler.

6.2 Grease lubrication

Composition of a grease

Greases can be differentiated in terms of their thickeners of varying composition and base oils. The base oils of greases are covered by the information in the section Oil lubrication ▶ 81.

Conventional greases have metal soaps as thickeners and a mineral base oil ▶ 72 | 3. They also contain additives. These have a specific influence on, for example, the characteristics in relation to wear prevention, corrosion prevention or resistance to ageing. These combinations of additives are not, however, fully effective across every temperature and load range.

Greases exhibit widely varying behaviour in response to environmental influences such as temperature and moisture.

3
 Type of grease

- ① Thickener
- ② Additives
- ③ Base oil
- ④ Grease

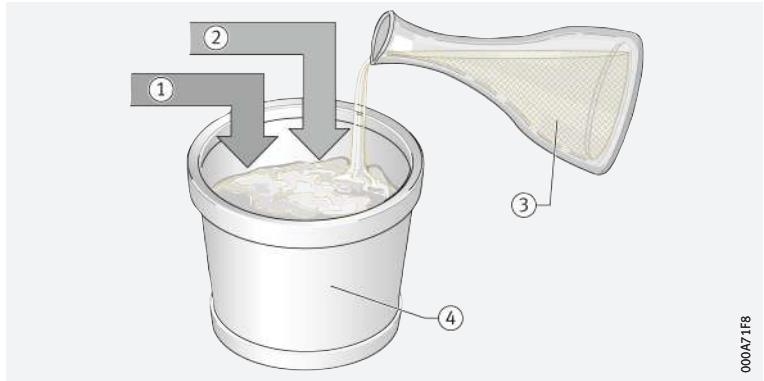

Lubricants must always be checked for their compatibility with:

- other lubricants
- anti-corrosion agents
- thermoplastics, thermosets and elastomers
- light and non-ferrous metals
- coatings
- colouring agents and paints
- and the environment. When considering compatibility with the environment, attention must be paid to toxicity, biodegradability and water pollution class.

Type of grease

The characteristics of a grease are dependent on:

- the base oil
- the viscosity of the base oil (this is significant for the speed range)
- the thickener (the shear strength is significant for the speed range)
- the additives.

Consistency of greases

Greases are subdivided into consistency classes (NLGI classes to DIN 51818). For rolling bearings, classes 1, 2, 3 should be used in preference ➤ 72 | 4.

4

Consistency of greases

NLGI classes

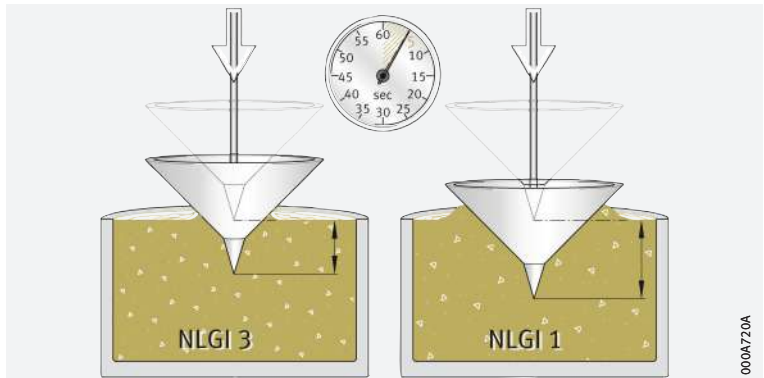

Selection of suitable grease

The grease is determined by the operating conditions

Rolling bearing greases K to DIN 51825 are suitable.

Greases should be selected in accordance with the operating conditions of the bearing:

- temperature
- pressure conditions ➤ 74
- speed ➤ 74
- water and moisture ➤ 74.



The grease must correspond to the operating temperatures

Operating temperature range

The operating temperature range of the grease must correspond to the range of possible operating temperatures in the rolling bearing.

Grease manufacturers indicate an operating temperature range for their rolling bearing greases K to DIN 51825.

The upper value is determined in accordance with DIN 51821 by means of testing on the FAG rolling bearing grease test rig FE9. At the upper operating temperature, a 50% failure probability rate (F_{50}) of at least 100 hours must be achieved in this test.

The lower value is defined in accordance with DIN 51825 by means of flow pressure. The flow pressure of a grease is the pressure required to press a stream of grease through a defined nozzle. For greases of type K, the flow pressure at the lower operating temperature must be less than 1 400 mbar.

The use of flow pressure in determining the lower operating temperature only indicates, however, whether the grease can be moved at this temperature. This cannot be used to give an indication of its suitability for use in rolling bearings at low temperatures.

In addition to the lower operating temperature of a grease, therefore, the low temperature frictional torque is also determined in accordance with ASTM D 1478 or IP 186/93. At the lower operating temperature, the starting torque must not exceed 1 000 Nmm and the running torque must not exceed 100 Nmm.

Schaeffler recommends that greases should be used in accordance with the bearing temperature normally occurring in the standard operating range, in order to achieve a reliable lubricating action and an acceptable grease operating life [▶ 73](#) | [□ 5](#).

At low temperatures, greases release very little base oil. This can result in lubricant starvation. Schaeffler therefore recommends that greases are not used below the lower continuous limit temperature $\vartheta_{\text{lower limit}}$ on a permanent basis [▶ 73](#) | [□ 5](#). This is approx. 20 K above the lower operating temperature of the grease as stated by the grease manufacturer.

The upper continuous limit temperature $\vartheta_{\text{upper limit}}$ must not be exceeded if a temperature-induced reduction in the grease operating life is to be avoided; see Grease operating life [▶ 75](#).



At consistently low temperatures (for example in cold store applications), it must be ensured that the grease releases sufficient oil in relation to the bearing type.



Operating temperature range

ϑ = operating temperature
 ΔT = temperature difference

- ① Upper operating temperature according to grease manufacturer
- ② $\vartheta_{\text{upper limit}}$
- ③ $\vartheta_{\text{lower limit}}$
- ④ Lower operating temperature according to grease manufacturer
- ⑤ Standard operating range

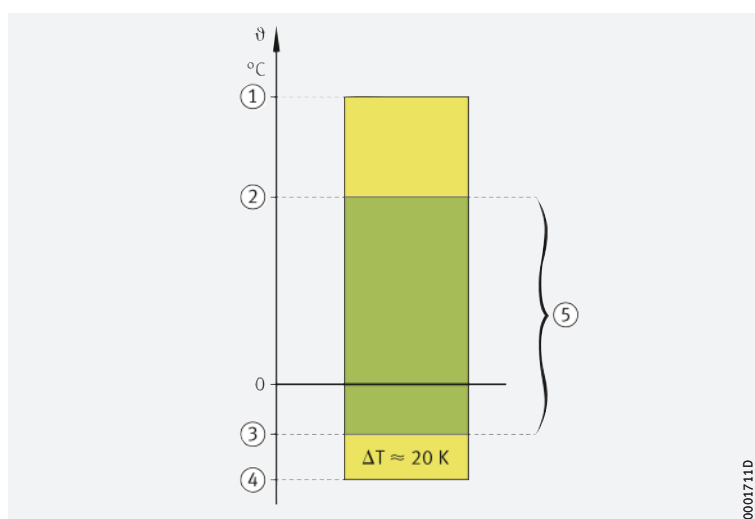

0001711D

The pressure properties are dependent on the viscosity

Pressure properties

The viscosity at operating temperature must be sufficiently high for the formation of a lubricant film capable of supporting loads. At high loads, greases with EP characteristics (“extreme pressure”) and high base oil viscosity should be used (KP grease to DIN 51825). Such greases should also be used for bearings with substantial sliding or line contact.

Silicone greases should only be used at low loads ($P \leq 0,03 \cdot C$).



Greases with solid lubricants should preferably be used for applications with mixed or boundary friction conditions. The solid lubricant particle size must not exceed 5 µm.

Speed

Speed parameter $n \cdot d_M$ is a criterion for grease selection

Greases should be selected in accordance with the speed parameter $n \cdot d_M$ for grease $\blacktriangleright 90 | \text{6}$:

- For rolling bearings running at high speeds or with a low starting torque, greases with a high speed parameter should be used
- For bearings running at low speeds, greases with a low speed parameter should be used.

Under centrifugal accelerations $> 500 \cdot g$, separation (of the thickener and base oil) may occur. In this case, please consult the lubricant manufacturer.



The consistency of polycarbamide greases can be altered by shear stresses to a greater extent than that of metal soap greases.

Water and moisture

Water reduces the operating life

Water in the grease has a highly detrimental effect on the operating life of bearings:

- the static behaviour of greases in the presence of water is assessed in accordance with DIN 51807 $\blacktriangleright 74 | \text{6}$
- the anti-corrosion characteristics can be tested according to DIN 51802 (Emcor test) – information is given in the grease manufacturer’s data sheets.



Behaviour in the presence of water in accordance with DIN 51807

- ① Blank
- ② Grease sample
- ③ Glass slide

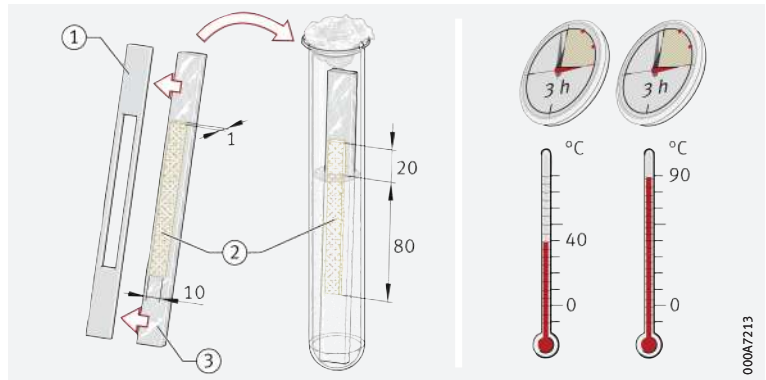



Grease operating life

The grease operating life t_{FG} applies where this is below the calculated bearing life and the bearings are not lubricated.

A guide value can be determined in approximate terms in accordance with **►75|f1**:

f1
Guide value
for grease operating life

$$t_{FG} = t_f \cdot K_T \cdot K_P \cdot K_R \cdot K_U$$

Legend

t_{FG}	h	Guide value for grease operating life
t_f	h	Basic grease operating life
K_T, K_P, K_R, K_U	-	Correction factors for temperature, load, oscillation and environment.



If a grease operating life > 3 years is required, this must be agreed in consultation with the lubricant manufacturer.

Guidelines on calculating the grease operating life **►76**.

Basic grease operating life

This applies under the preconditions according to **►75|g1**.

g1
Preconditions
for the basic grease operating life

	Precondition
Bearing temperature	< upper continuous limit temperature $\vartheta_{upper\ limit}$
Load ratio	$C_0/P = 20$
Speed and load	Constant
Load in main direction	Radial in radial bearings, axial in axial bearings
Axis of rotation	Horizontal for radial bearings
Inner ring	Rotating
Environmental influences	No disruptive influences

The basic grease operating life t_f is dependent on the bearing-specific speed parameter $k_f \cdot n \cdot d_M$ and is calculated using **►75|g7**.

Legend

k_f	-	Bearing type factor ►76 g2
n	min^{-1}	Operating speed or equivalent speed
d_M	mm	Mean bearing diameter $(d + D)/2$.

Calculation of basic grease operating life



Calculation
of basic grease operating life

t_f = basic grease operating life
 $k_f \cdot n \cdot d_M$ = bearing-specific speed parameter

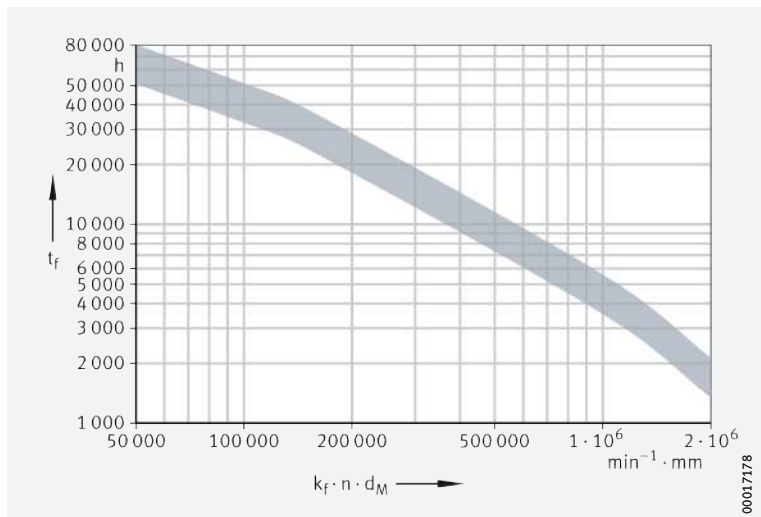

00017178

2
 Factor k_f – as a function
 of bearing type

Bearing type	Factor k_f
Deep groove ball bearings, single row, Generation C	0,8
Deep groove ball bearings, single row	1
Deep groove ball bearings, double row	1,5
Angular contact ball bearings, single row	1,6
Angular contact ball bearings, single row, X-life	1,3
Angular contact ball bearings, double row	2
Angular contact ball bearings, double row, X-life	1,6
Spindle bearings, $\alpha = 15^\circ$	0,75
Spindle bearings, $\alpha = 25^\circ$	0,9
Four point contact bearings	1,6
Four point contact bearings, X-life	1,3
Self-aligning ball bearings	1,45
Axial deep groove ball bearings	5,5
Axial angular contact ball bearings, single row	1,8
Axial angular contact ball bearings, double row	2
Cylindrical roller bearings, single row	2
Cylindrical roller bearings LSL, ZSL	3
Cylindrical roller bearings, double row	3
Cylindrical roller bearings, full complement	6
Tapered roller bearings	4
Spherical roller bearings	8
Toroidal roller bearings TORB	8
Needle roller and cage assemblies, needle roller bearings	3,6
Drawn cup needle roller bearings	4,2
Yoke type track rollers, stud type track rollers with cage, stud type track rollers with full complement cylindrical roller set	20
Yoke type track rollers, stud type track rollers, full complement needle roller set	40
Ball bearing type track rollers, single row	1
Ball bearing type track rollers, double row	2
Yoke type track rollers PWTR, stud type track rollers PWKR	6
Crossed roller bearings	4,4
Axial needle roller bearings, axial cylindrical roller bearings	58
Radial insert ball bearings, housing units	1

Guidelines on calculating the grease operating life

Combined rolling bearings

The radial and axial bearing components must be calculated separately; the decisive value is the shorter grease operating life.

Rotating outer ring

If the outer ring rotates, there may be a reduction in the grease operating life.

In the case of yoke and stud type track rollers:

- the angular misalignment must be zero
- the effect of the rotating outer ring on the grease operating life is taken into consideration in the bearing type factor k_f .



Restrictions of the calculation

The grease operating life cannot be determined using the method described in the following cases:

- if the grease can leave the bearing arrangement
 - there is excessive evaporation of the base oil
 - in bearing positions without seals
 - in axial bearings with a horizontal axis of rotation
- if air is sucked into the rolling bearing during operation
 - this can cause the grease to oxidise
- for bearing arrangements that have a vertical shaft
- in combined rotary and linear motion (the grease is distributed over the whole stroke length)
- if contamination, water or other fluids enter the bearing
- for spindle bearings
- for drawn cup roller clutches
- for screw drive bearings
- for high precision bearings for combined loads
- for super precision cylindrical roller bearings NN30.

The additional guidelines on lubrication in the product chapters must be observed.

Correction factors for determining the grease operating life

Temperature factor K_T

If the bearing temperature is higher than the continuous limit temperature $\vartheta_{\text{upper limit}}$, K_T must be determined from the diagram [77](#) | [8](#).



The diagram must not be used if the bearing temperature is higher than the upper operating temperature of the grease used [90](#) | [6](#). If necessary, a different grease must be selected or contact must be made with Schaeffler.

Temperature factor [8](#)

K_T = temperature factor

① K above $\vartheta_{\text{upper limit}}$

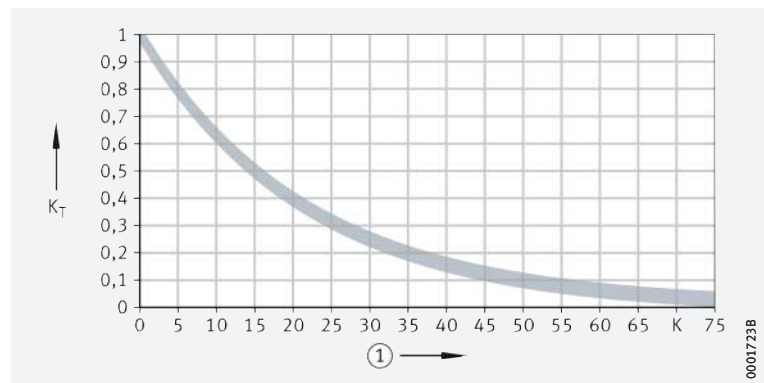

Load factor K_P

The factor K_P is dependent on the bearing and describes the reduction at higher load (this places greater strain on the grease) [78](#) | [9](#) and [78](#) | [3](#).

9
 Load correction factor K_p

K_p = load correction factor
 C_0/P = ratio between basic static load rating and equivalent dynamic bearing load

①, ②, ③, ④ ▶ 78 | 3

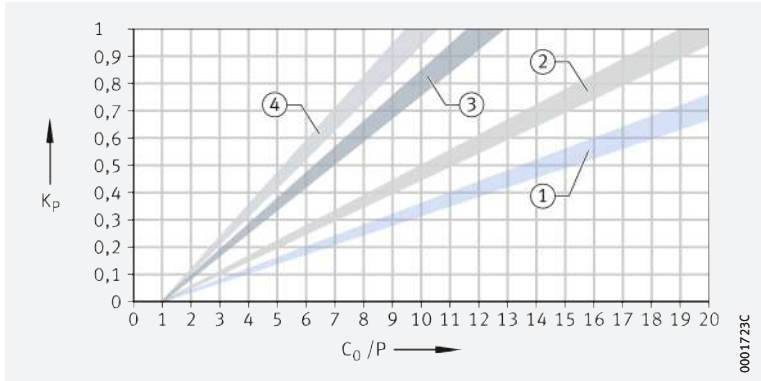

3
 Correction factor for load K_p

Curve ▶ 78 9	Bearing type
①	Axial angular contact ball bearings, double row
	Axial deep groove ball bearings
	Axial needle roller bearings, axial cylindrical roller bearings
	Crossed roller bearings
②	Spherical roller bearings with central rib
	Needle roller and cage assemblies, needle roller bearings
	Drawn cup needle roller bearings
	Cylindrical roller bearings, double row (excluding NN30)
	Yoke type track rollers PWTR, stud type track rollers PWKR
	Yoke and stud type track rollers with cage, full complement cylindrical roller set
③	Yoke and stud type track rollers, full complement needle roller set
	Four point contact bearings
	Cylindrical roller bearings LSL, ZSL
	Cylindrical roller bearings, full complement
	Cylindrical roller bearings, single row (constant or alternating load)
	Tapered roller bearings
	Barrel roller bearings
	Spherical roller bearings without central rib (E1)
Toroidal roller bearings	
④	Deep groove ball bearings (single or double row)
	Angular contact ball bearings (single or double row)
	Self-aligning ball bearings
	Ball bearing track rollers (single or double row)
	Radial insert ball bearings, housing units.

Oscillation factor K_R The factor K_R applies for an angle of oscillation $\varphi < 180^\circ$ ▶ 79 | 10.
 Oscillating motion places a greater strain on the grease than does rotating motion.



In order to reduce fretting corrosion, the lubrication interval should be reduced.

If the rolling elements do not undergo complete rotation, please consult Schaeffler.



10

Correction factor for oscillation K_R

K_R = correction factor for oscillation
 φ = angle of oscillation

① Angle of oscillation $\varphi < 5^\circ$ requires special lubricants

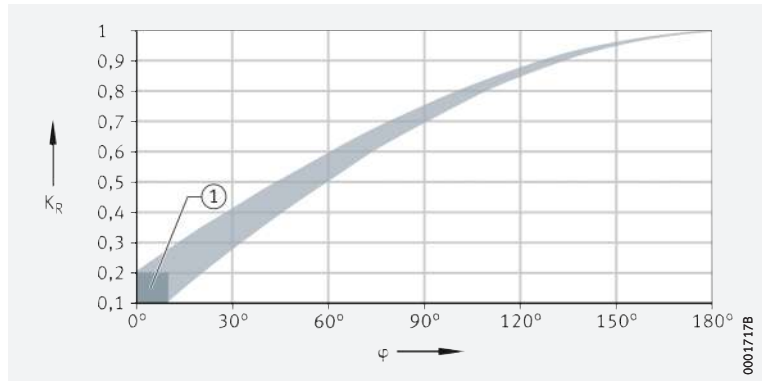

Environmental factor K_U

The factor K_U takes account of the influences of moisture, shaking forces, slight vibration (leading to fretting corrosion) and shocks **79** **4**. It does not take account of extreme environmental influences such as water, aggressive media, contamination, radiation and extreme vibrations such as those occurring in vibratory machines. In relation to contamination, the influence of contamination on rating life calculation must also be noted.

4

Environment factor K_U

Environmental influence	Factor K_U
Slight (e.g. test rig)	1
Moderate (standard)	0,8
Heavy (e.g. outdoor application)	0,5

Relubrication intervals

Observe lubrication intervals



Where rolling bearings are relubricated, attention must be paid to the lubrication interval in order to ensure reliable function of the bearings. The precise lubrication interval should be determined by tests conducted under application conditions. To do this:

- sufficiently long observation periods must be used
- the condition of the grease must be checked at regular intervals.

For reasons of operational reliability, relubrication intervals of > 1 year are not recommended.

Lubrication interval guide value

Experience shows that the guide value for most applications is **79** **f1 2**.

f2

Guide value for relubrication interval

$$t_{FR} = 0,5 \cdot t_{FG}$$

Legend

t_{FR}	h	Guide value for relubrication interval
t_{FG}	h	Guide value for grease operating life 75 .

Relubrication conditions

The grease used for relubrication must be the same as that used in initial greasing. If other greases are used, the miscibility and compatibility of the greases must be checked **80**.

Relubrication quantity

Due to the compact construction of the bearings, relubrication should be carried out using 50% to 80% of the initial greasing quantity (recommendation).

If feed lines filled with air are present, the filling volume of the feed lines should be included in calculation of the relubrication quantity.

Relubrication

Relubrication should always be carried out as follows:

- with the bearing still warm from operation and rotating if safe to do so
- before the bearing comes to rest if safe to do so
- before extended breaks in operation.

Relubrication should continue until a fresh collar of grease appears at the seal gaps. Old grease must be allowed to leave the bearing unhindered.

Grease reservoir

The initial greasing quantity is between 30% and 100% of the available volume in the bearing, dependent on the bearing type and operating conditions.

A grease reservoir can extend the grease operating life. The grease in the reservoir must be in constant contact with the grease on the raceway. The grease operating life does not increase proportionally with the size of the grease reservoir.

The volume of the grease reservoir should correspond to the volume in the bearing between the inner and outer ring (not taking account of the cage and rolling elements) ➤ 80 | 11 and ➤ 80 | 12.

Evaporation of the base oil should be prevented by design measures, for example by sealing shields ➤ 80 | 11 and ➤ 80 | 12.

11
 Grease reservoir on one side

- ① Sealing washer
- ② Grease reservoir

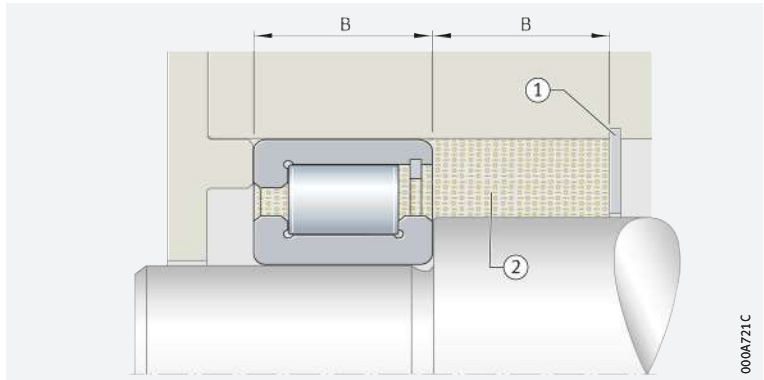

12
 Grease reservoir on both sides

- ① Sealing washer
- ② Grease reservoir

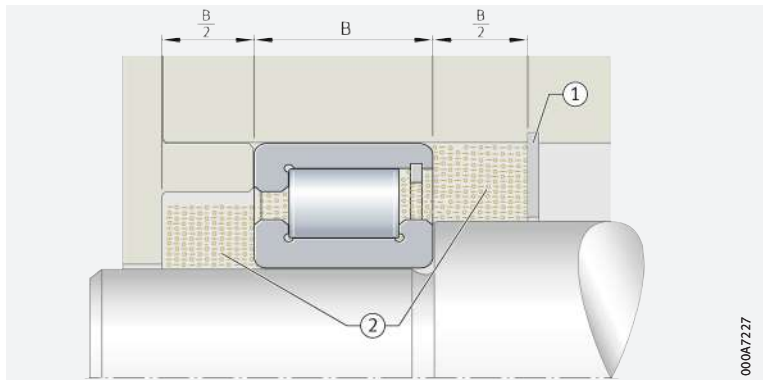

Miscibility

Preconditions

Mixtures of greases should be avoided if at all possible. If they are unavoidable, the following preconditions must be fulfilled:

- The base oil must be the same
- The thickener types must match
- The base oil viscosities must be similar (they must not differ by more than one ISO VG class)
- The consistency must be identical (NLGI class).



Miscibility of greases must always be agreed in consultation with the lubricant manufacturer.

Even when these preconditions are fulfilled, impairment of the performance capability of the mixed grease cannot be ruled out. If a decision is taken to change to a different grease grade, the grease should be rinsed out if this is possible. Further relubrication should be carried out after a shortened period.



If incompatible greases are mixed, this can lead to considerable structural changes. Substantial softening of the grease mixture may also occur. Definite statements on miscibility can only be obtained by means of suitable tests.

Storage life

In general, the greases can be stored for 3 years.

Preconditions

The preconditions are:

- a closed room or store
- temperatures between 0 °C and +40 °C
- relative humidity no more than 65%
- no influence of chemical agents (vapours, gases, fluids)
- the rolling bearings are sealed.

Lubricants age due to environmental influences. The information provided by lubricant manufacturers must always be observed.



After long periods of storage, the start-up frictional torque of greased bearings can be temporarily higher than normal. The lubricity of the grease may also have deteriorated.

Since the lubrication characteristics of greases vary and different raw materials may be used for greases of the same name, Schaeffler cannot offer any guarantees either for the lubricants used by customers for relubrication or for their characteristics.

6.3 Oil lubrication

Mineral oils or synthetic oils are suitable

For the lubrication of rolling bearings, mineral oils and synthetic oils are essentially suitable. Oils with a mineral oil base are used most frequently. They must, as a minimum, fulfil the requirements in accordance with DIN 51517 or DIN 51524.



Special oils, often synthetic oils, are used under extreme operating conditions or where there are special requirements relating to oil resistance. In these cases, please consult the lubricant manufacturers or Schaeffler.

Operating temperatures

The information provided by the lubricant manufacturer should be taken as authoritative.

Selection of suitable oil

The achievable bearing life and security against wear are higher with better separation of the contact surfaces by a lubricant film ► 81 | 13.



Lubricant film in the contact zones

h_{\min} = minimum lubricant film thickness

- ① Entry zone
- ② Pressure curve according to EHD theory
- ③ Exit zone
- ④ Lubricant

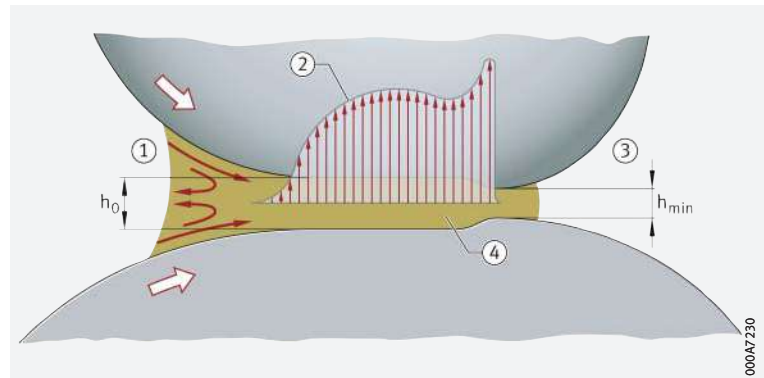

000A7230

Reference viscosity for mineral oils

Guide value for ν_1

The guide value for ν_1 is dependent on the mean bearing diameter d_M and the speed n . It takes account of the EHD theory of lubricant film formation and practical experience.

Depending on the operating speed, the oil at operating temperature must have at least the reference viscosity $\nu_1 \geq 82$ for $n \leq 14$ and $\nu_1 \geq 82$ for $n \leq 15$.

14
 Calculating
 the reference viscosity ν_1

- ν_1 = reference viscosity
- d_M = mean bearing diameter
- n = speed

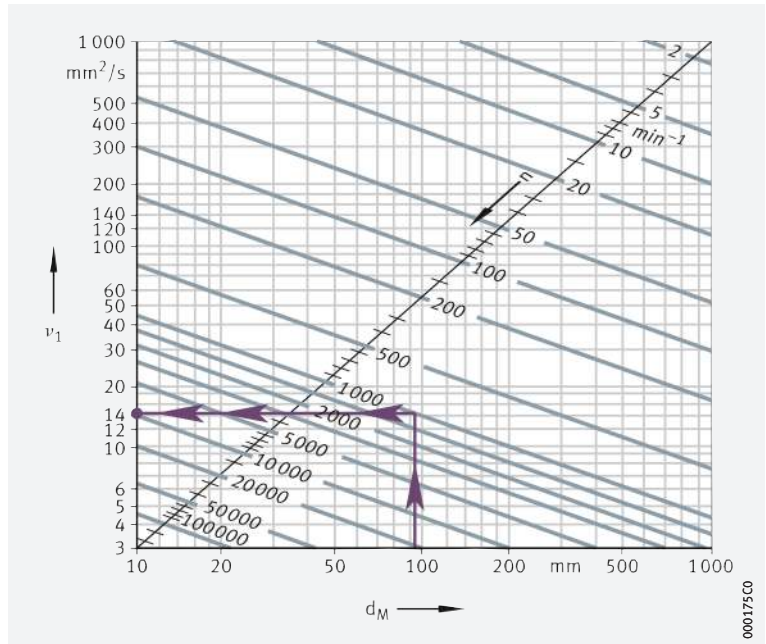

15
 ν/ϑ diagram for mineral oils

- ν = operating viscosity
- ϑ = operating temperature
- ν_{40} = viscosity at +40 °C

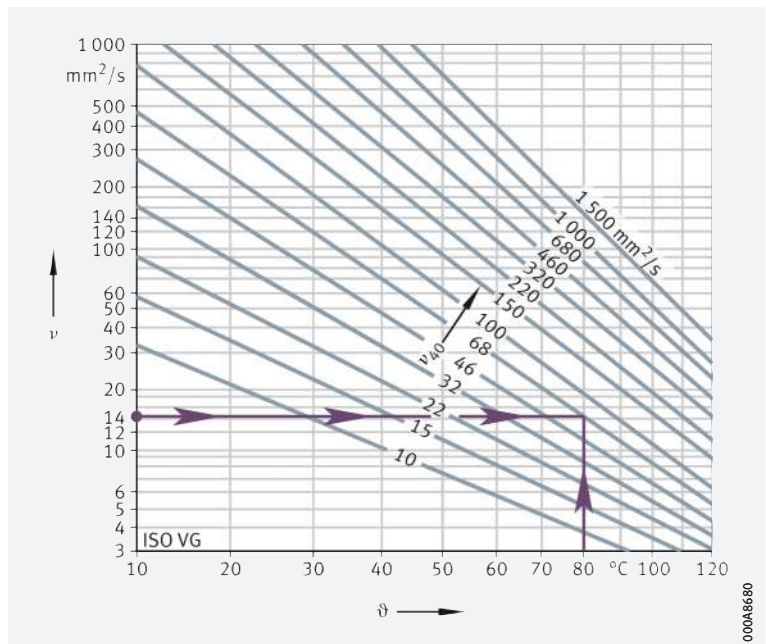



- Calculation of reference viscosity**
- ☞ *Determine ν_1* The reference viscosity ν_1 is calculated as follows:
 - Allocate ν_1 to a nominal viscosity between ISO VG 10 and ISO VG 1500 (mid-point viscosity in accordance with ISO 3448)
 - Round intermediate values to the nearest ISO VG (due to the steps between groups).



This method cannot be used for synthetic oils, since these have different V/P (viscosity/pressure) and V/T (viscosity/temperature) characteristics. In these cases, please consult Schaeffler.

- Influence of temperature on viscosity**
- ☞ *Aim for VI of 95* As the temperature increases, the viscosity of the oil decreases. This temperature-dependent change in the viscosity is described using the viscosity index VI. For mineral oils, the viscosity index should be at least 95.
- When selecting the viscosity, the lower operating temperature must be taken into consideration, since the increasing viscosity will reduce the flowability of the lubricant. As a result, the level of power losses may increase.

- ☞ *Viscosity ratio κ* A very long life can be achieved with a viscosity ratio $\kappa = \nu/\nu_1 = 3$ to 4 ($\nu =$ operating viscosity). Highly viscous oils do not, however, bring only advantages. In addition to the power losses arising from lubricant friction, there may be problems with the feed and removal of oil at low or even at normal temperatures.
- ☞ *Aim for long fatigue life* The oil selected must be sufficiently viscous that it gives the highest possible fatigue life. It must also be ensured that the bearings are always supplied with adequate quantities of oil.

- Pressure properties and anti-wear additives**
- ☞ *Oils with wear additives* If the bearings are subjected to high loads or if the operating viscosity ν is less than the reference viscosity ν_1 , oils with anti-wear additives (type P in accordance with DIN 51502) should be used. Such oils are also necessary for rolling bearings with a substantial proportion of sliding contact (for example, bearings with line contact). These additives form boundary layers to reduce the harmful effects of metallic contact occurring at various points (wear).



The suitability of these additives varies and is normally heavily dependent on temperature. Their effectiveness can only be assessed by means of testing in the rolling bearing (for example on our test rig FE8 to DIN 51819).

Silicone oils should only be used for low loads ($P \leq 0,03 \cdot C$).

- Compatibility**
- ☞ *Check compatibility prior to use* Before an oil is used, its behaviour must be checked in relation to plastics, seal materials (elastomers) and light and non-ferrous metals. This must always be checked under dynamic loading and at operating temperature. Synthetic oils must always be checked for their compatibility. The lubricant manufacturer must be consulted on this at the same time.

- Miscibility**
- ☞ *Avoid mixing different oils* The mixing of different oils should be avoided wherever possible. In particular, the presence of different additive packages may lead to undesirable interactions.
- In general, oils with a mineral oil base and the same classification are miscible, for example type HLP with type HLP. The viscosities should vary by no more than one ISO VG class.



Synthetic oils must always be checked for their compatibility. The lubricant manufacturer must be consulted on this at the same time. Miscibility must be checked in advance for each individual case.

☞ *An oil filter should be used*

Cleanliness

The cleanliness of the oil has a considerable influence on the rating life of the bearings ➤ 34. Schaeffler therefore recommends that an oil filter should be provided; attention must be paid to the filtration rate. The filter mesh should be $< 25 \mu\text{m}$.

☞ *Proven methods*

Lubrication methods

The essential lubrication methods are:

- drip feed oil lubrication
- pneumatic oil lubrication (to protect the environment, this should be used as a substitute for oil mist lubrication)
- oil bath lubrication (immersion or sump lubrication)
- recirculating oil lubrication.

☞ *Drip feed oil lubrication*

This is suitable for bearings running at high speeds ➤ 84 | ☞ 16. The oil quantity required is dependent on the type and size of bearing, the operating speed and the load. The guide value is between 3 drops/min and 50 drops/min for each rolling element raceway (one drop weighs approx. 0,025 g).

Excess oil must be allowed to flow out of the bearing arrangement.

☞ 16
Drip feed oil lubrication

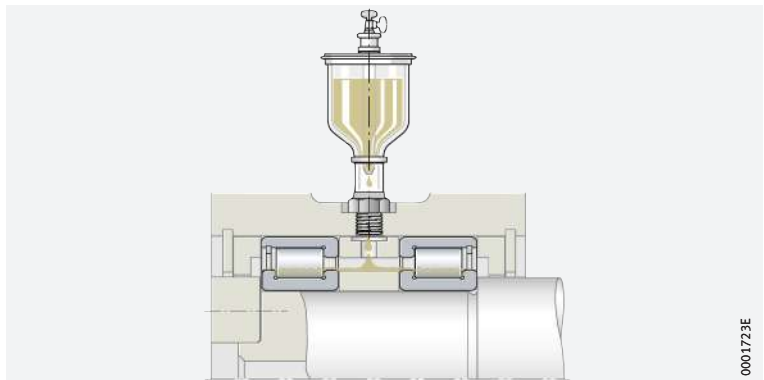

☞ *Pneumatic oil lubrication*

This method is particularly suitable for radial bearings running at high speeds and under low loads ($n \cdot d_M = 800\,000$ to $3\,000\,000 \text{ min}^{-1} \cdot \text{mm}$) ➤ 85 | ☞ 17. Clean compressed air free from moisture feeds oil to the bearing. This generates an excess pressure, which prevents contaminants from entering the bearing.

With a pneumatic oil lubrication system designed for minimal quantity lubrication, low frictional torque and a low operating temperature can be achieved.

☞ *Parameters*

Parameters for design of the lubrication system should be requested from the equipment manufacturers.



Pneumatic oil lubrication of axial bearings should be avoided if possible. The oil quantity required for adequate supply is dependent on the bearing type.

Pneumatic oil lubrication has little cooling effect.

Follow the instructions provided by the manufacturers of the lubrication systems.



17

Pneumatic oil lubrication

- ① To the pneumatic oil unit

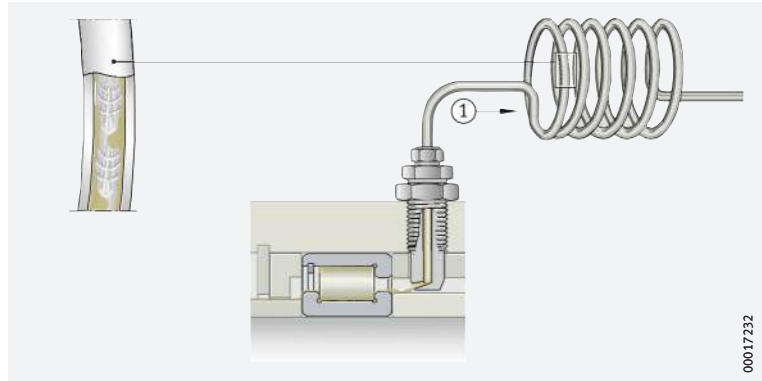

00017232

Oil bath lubrication

The oil level should reach the centre line of the lowest rolling element ➤ 85 | 18. If the oil level is higher than this, the bearing temperature may increase at high circumferential velocities (with losses due to splashing). Furthermore, foaming of the oil may occur.

$n \cdot d_M$ values

In general, it is suitable for speeds up to $n \cdot d_M = 300\,000 \text{ min}^{-1} \cdot \text{mm}$. At $n \cdot d_M < 150\,000 \text{ min}^{-1} \cdot \text{mm}$, the bearing may be completely immersed.

Axial bearings

In bearings with an asymmetrical cross-section, oil return ducts must be provided due to the pumping effect so that recirculation can be achieved. In axial bearings, the oil level must cover the inside diameter of the axial cage.

Proportion oil quantity adequately

The oil quantity in the housing must be adequately proportioned, as otherwise very short oil change intervals will be necessary.

18

Oil bath lubrication

- ① Oil sump

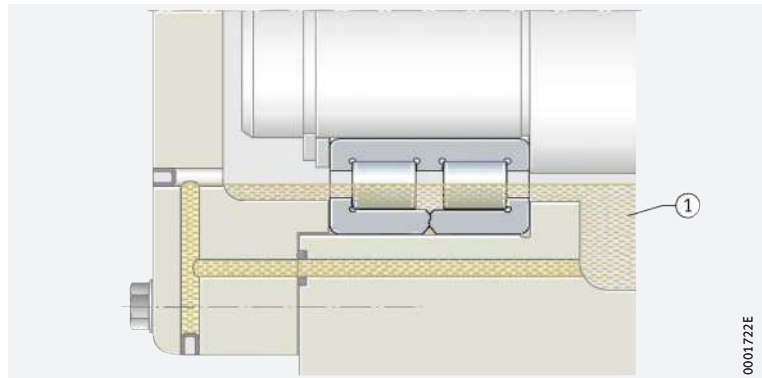

0001722E

Recirculating oil lubrication

In recirculating oil lubrication, the oil is subjected to additional cooling ➤ 85 | 19. The oil can therefore dissipate heat from the bearing. The quantity of oil required for heat dissipation is dependent on the cooling conditions.

19

Recirculating oil lubrication

- ① Filter
② Pump
③ Cooling system

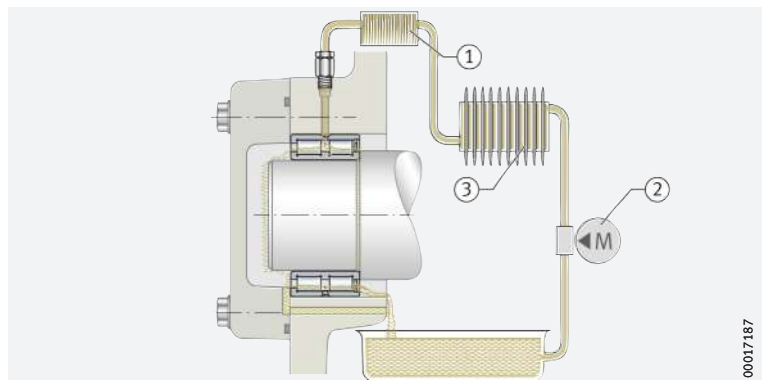

00017187

Oil quantity The oil quantities are matched to the operating conditions **► 86** | **☐ 20**. The diagram indicates oil quantities that can be fed through the bearing without pressure with a side feed arrangement and banking up to the lower edge of the shaft.

Bearings with asymmetrical cross-section For bearings with an asymmetrical cross-section (such as angular contact ball bearings, tapered roller bearings, axial spherical roller bearings), larger throughput quantities are permissible due to the pumping effect than for bearings with a symmetrical cross-section. Large quantities can be used to dissipate wear debris or heat.

☐ 20
 Oil quantities

- \dot{V} = oil quantity
- D = outside bearing diameter
- a = oil quantity sufficient for lubrication
- b = upper limit for bearings of symmetrical design
- c = upper limit for bearings of asymmetrical design
- $a_1; b_1; c_1: D/d > 1,5$
- $a_2; b_2; c_2: D/d \leq 1,5$
- ① Increasing oil quantity required for heat dissipation
- ② No heat dissipation required

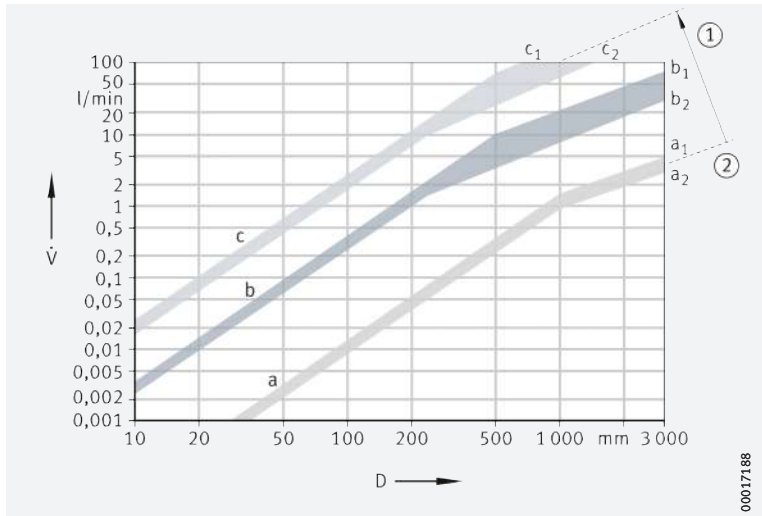

Design of adjacent construction for oil lubrication



The lubrication holes in the housing and shaft must align with those in the rolling bearings. Adequate cross-sections must be provided for annular slots, pockets, etc. The oil must be able to flow out without pressure (this prevents oil build-up and additional heating of the oil).

- Axial bearings**
- Guide values**

In axial bearings, the oil must always be fed from the inside to the outside. The cross-section of the oil outlet hole should be significantly larger than that of the inlet **► 86** | **☐ 21**.

The cross-section A_{rab} is dependent on the oil quantity and the viscosity **► 86** | **f 3**.

f 3
 Outlet cross section

$$A_{rab} = K_{ab} \cdot A_{ab}$$

Legend

A_{rab}	mm ²	Outlet cross-section taking account of viscosity
K_{ab}	-	Correction factor for viscosity ► 87 ☐ 5
A_{ab}	mm ²	Outlet cross-section ► 86 ☐ 21 .

☐ 21
 Outlet cross-section (guide values)

- A_{ab} = cross-section for pressure-free oil runout
- \dot{V} = oil quantity

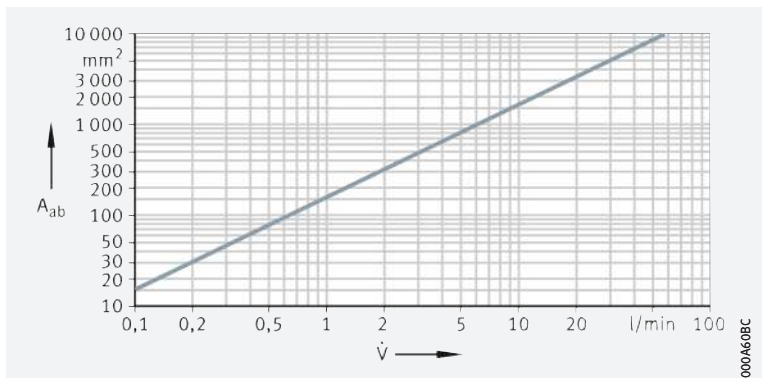



5
Correction factor K_{ab}

Viscosity ν mm ² /s		Factor K_{ab}	
from	to	from	to
–	30	1	–
30	60	1,2	1,6
60	90	1,8	2,2
90	120	2,4	2,8
120	150	3	3,4

Oil injection lubrication

Advantages and disadvantages

In bearings running at high speeds, the oil is injected into the gap between the cage and bearing ring ➤ 87 | 22. Injection lubrication using large recirculation quantities is associated with high power loss.

Heating of the bearings can only be held within limits with a considerable amount of effort. The appropriate upper limit for the speed parameter $n \cdot d_M = 1\,000\,000 \text{ min}^{-1} \cdot \text{mm}$ for recirculating lubrication with suitable bearings (for example spindle bearings) can be exceeded to a considerable degree when using injection lubrication.

22
Oil injection lubrication

- ① Angular contact ball bearing
- ② Tapered roller bearing
- ③ Oil outlet holes

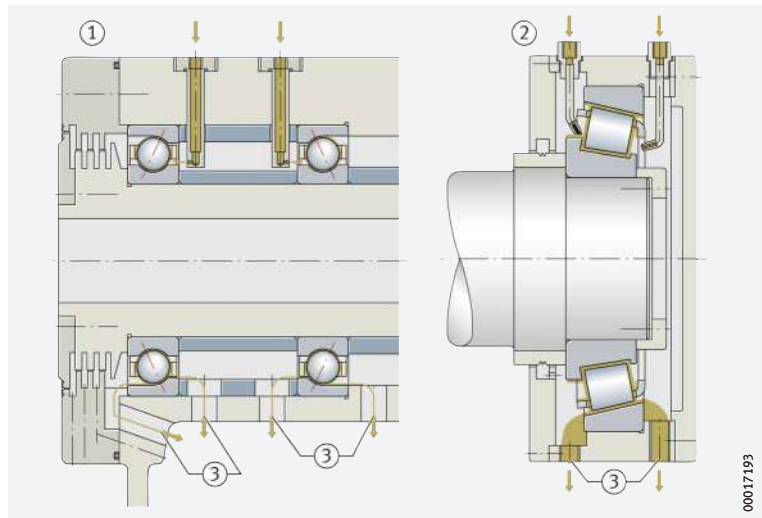

Heat dissipation by the lubricant

Values \dot{Q}_L and \dot{V}_L can be calculated

Oil can dissipate frictional heat from the bearing. It is possible to calculate the heat flow \dot{Q}_L that is dissipated with the lubricant and the necessary lubricant volume flow \dot{V}_L .

Heat flow

The total dissipated heat flow due to possible heating by an external source can be calculated using ➤ 87 | 4, while the heat flow dissipated by the lubricant can be calculated using ➤ 87 | 5.

4
Total dissipated heat flow

$$\dot{Q} = 10^{-6} \cdot \frac{\pi}{30} \cdot n \cdot (M_0 + M_1) + \dot{Q}_E$$

5
Heat flow dissipated by the lubricant

$$\dot{Q}_L = \dot{Q} - \dot{Q}_S$$

Legend

\dot{Q}	kW	Total dissipated heat flow
n	min ⁻¹	Operating speed or equivalent speed
M_0	Nmm	Frictional torque as a function of speed
M_1	Nmm	Frictional torque as a function of load
\dot{Q}_E	kW	Heat flow due to heating by external source
\dot{Q}_L	kW	Heat flow dissipated by the lubricant
\dot{Q}_S	kW	Heat flow dissipated via the bearing seating surfaces.

Lubricant volume flow The lubricant volume flow can be calculated approximately **► 88 | f. 6.**

f. 6
 Lubricant volume flow

$$\dot{V}_L = \frac{\dot{Q}_L}{0,0286 \cdot \Delta\vartheta_L}$$

Legend

\dot{V}_L	l/min	Lubricant volume flow
\dot{Q}_L	kW	Heat flow dissipated by the lubricant
$\Delta\vartheta_L$	K	Difference between oil inlet temperature and oil outlet temperature.

Guide values If these values cannot be calculated, the guide values according to **► 88 | 23** apply for the temperature difference of $\Delta\vartheta_L = 10$ K.

23
 Guide values for the oil quantity in cooling and lubrication

N_R = frictional power

\dot{V} = oil quantity

- ① No account is taken of thermal conduction, radiation or convection
- ② Empirical values for normal cooling conditions
- ③ Empirical values for very good cooling conditions

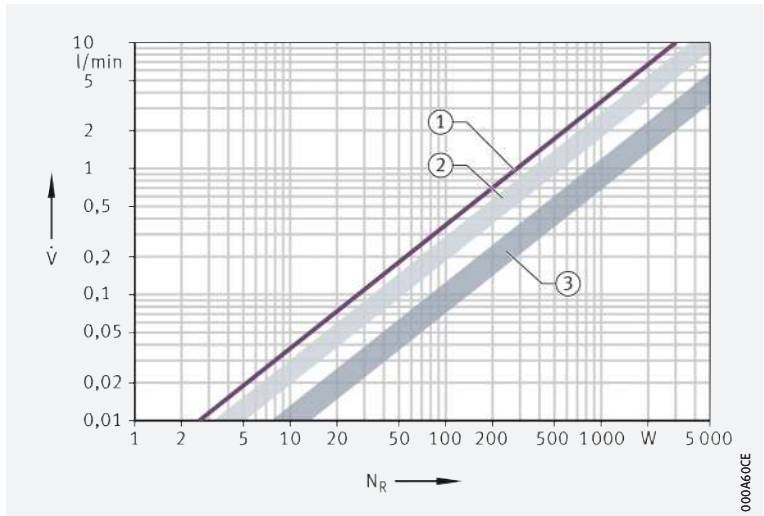

Oil changes

One oil change per year is usually sufficient

At temperatures in the bearing of less than +50 °C and with only slight contamination, an oil change once per year is generally sufficient. Guide values for oil change intervals are given in **► 88 | 24**. The precise oil change intervals should be agreed in consultation with the oil manufacturer.

Severe operating conditions

Under severe conditions, the oil should be changed more frequently. This applies, for example, in the case of higher temperatures and low oil quantities with a high circulation index. The circulation index indicates how often the entire oil volume available is recirculated or pumped per hour **► 88 | f. 7.**

f. 7
 Circulation index

$$\text{Circulation index} = \frac{\text{Pump displacement m}^3 / \text{h}}{\text{Container volume m}^3}$$

24
 Oil change intervals

ϑ = oil sump temperature
 t = oil change interval

- ① Synthetic gearbox oils
- ② Mineral gearbox oils

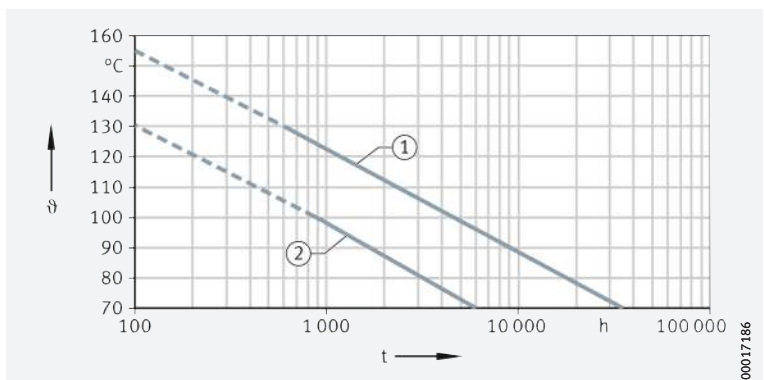



6.4 Lubricating grease groups

6
 Greases

Designation ³⁾	Classification	Type of grease
GA01	Ball bearing grease for $\vartheta < +180$ °C	Polycarbamide Ester oil
GA02	Ball bearing grease for $\vartheta < +160$ °C	Polycarbamide SHC
GA13	Standard ball bearing and insert bearing grease for $D > 62$ mm	Lithium soap Mineral oil
GA14	Low-noise ball bearing grease for $D \cong 62$ mm	Lithium soap Mineral oil
GA15	Low-noise ball bearing grease for high speeds	Lithium soap Ester oil/SHC
GA22	Free-running grease with low frictional torque	Lithium soap Ester oil, mineral oil
L069	Radial insert ball bearing grease for wide temperature range	Polycarbamide Ester oil
GA08	Grease for line contact	Lithium complex soap Mineral oil
GA26	Standard grease for drawn cup roller clutches	Calcium/ lithium soap Mineral oil
GA28	Screw drive bearing grease	Lithium soap Synthetic oil/mineral oil
GA11	Rolling bearing grease resistant to media for temperatures up to +250 °C	PTFE Alkoxyfluoroether
GA47	Rolling bearing grease resistant to media for temperatures up to +140 °C	Barium complex soap Mineral oil

¹⁾ The upper continuous limit temperature $\vartheta_{upperlimit}$ must not be exceeded if a reduction in the grease operating life due to temperature is to be avoided.

²⁾ Dependent on bearing type.

³⁾ **GA..** Stands for **Grease Application Group..**, based on Grease Spec 00.



Operating temperature range °C		Upper continuous limit temperature $\vartheta_{\text{upper limit}}^{1)}$ °C	NLGI class		Speed parameter $n \cdot d_M$ min ⁻¹ · mm	ISO VG class (base oil) ²⁾		Designation ³⁾	Recommended Arcanol grease for relubrication
from	to		from	to		from	to		
-30	+180	+125	2	3	600 000	68	220	GA01	-
-40	+160	+90	2	3	500 000	68	220	GA02	-
-20	+120	+75	3	-	500 000	68	150	GA13	MULTI3
-30	+120	+75	2	-	500 000	68	150	GA14	MULTI2
-40	+120	+75	2	3	1 000 000	22	32	GA15	-
-50	+120	+70	2	-	1 500 000	10	22	GA22	-
-40	+180	+120	2	-	700 000	68	220	L069	-
-20	+140	+95	2	3	500 000	150	320	GA08	LOAD150
-20	+80	+60	2	-	500 000	10	22	GA26	-
-30	+140	+80	2	-	800 000	15	100	GA28	MULTITOP
-30	+260	+200	2	-	300 000	460	680	GA11	TEMP200
-20	+130	+70	1	2	350 000	150	320	GA47	-

6.5 Arcanol rolling bearing greases



Arcanol rolling bearing greases

+++ = extremely suitable

++ = highly suitable

+ = suitable

- = less suitable

-- = not suitable

Available containers ▶ 96 | 8

Grease	Characteristic applications	Operating temperature		Continuous limit temperature °C
		°C from	°C to	
Multi-purpose greases	MULTITOP <ul style="list-style-type: none"> Ball and roller bearings in rolling mills Construction machinery Spinning and grinding spindles Automotive engineering 	-50 ¹⁾	+140	+80
	MULTI2 <ul style="list-style-type: none"> Ball bearings up to $D \leq 62$ mm in electric motors Agricultural and construction machinery Household appliances 	-30	+120	+75
	MULTI3 <ul style="list-style-type: none"> Ball bearings from $D > 62$ mm in electric motors Agricultural and construction machinery Fans 	-30	+120	+75
High loads	LOAD150 <ul style="list-style-type: none"> Ball, roller and needle roller bearings Linear guidance systems in machine tools 	-20	+140	+95
	LOAD220 <ul style="list-style-type: none"> Ball and roller bearings in rolling mill plant Paper machinery Rail vehicles 	-20	+140	+80
	LOAD400 <ul style="list-style-type: none"> Ball/roller bearings in mining machinery Construction machinery Wind turbine main bearings 	-40 ¹⁾	+130	+80
	LOAD460 <ul style="list-style-type: none"> Ball/roller bearings Wind turbines Bearings with pin cage 	-40 ¹⁾	+130	+80
	LOAD1000 <ul style="list-style-type: none"> Ball/roller bearings in mining machinery Construction machinery Cement plant 	-30 ¹⁾	+130	+80

¹⁾ Measurement values according to Schaeffler FE8 low temperature test.



Thickener	Base oil	Consistency NLGI	Base oil viscosity at +40 °C mm ² /s	Tempera- tures		Low friction, high speed	High load, low speed	Vibra- tions	Support for seals	Relubri- cation facility
				Low	High					
Lithium soap	Partially synthetic oil	2	82	+++	++	++	+++	++	+	+++
Lithium soap	Mineral oil	2	110	++	+	+	+	+	+	+++
Lithium soap	Mineral oil	3	80	++	+	+	+	++	++	++
Lithium complex soap	Mineral oil	2	160	+	++	-	+++	++	++	++
Lithium/ calcium soap	Mineral oil	2	245	+	+	-	+++	++	++	++
Lithium/ calcium soap	Mineral oil	2	400	+	+	-	+++	++	++	++
Lithium/ calcium soap	Mineral oil	1	400	++	+	-	+++	++	-	++
Lithium/ calcium soap	Mineral oil	2	1 000	+	+	--	+++	++	++	++

continued ▼



Arcanol rolling bearing greases

- +++ = extremely suitable
- ++ = highly suitable
- + = suitable
- = less suitable
- = not suitable

Available containers > 96 | 8

Grease	Characteristic applications	Operating temperature		Continuous limit temperature	
		°C			
		from	to	°C	
High temperatures	TEMP90	<ul style="list-style-type: none"> ■ Ball and roller bearings in couplings ■ Electric motors ■ Automotive engineering 	-40	+160	+90
	TEMP110	<ul style="list-style-type: none"> ■ Ball and roller bearings in electric motors ■ Automotive engineering 	-35	+160	+110
	TEMP120	<ul style="list-style-type: none"> ■ Ball and roller bearings in continuous casting plant ■ Paper machinery 	-30	+180	+120
	TEMP200	<ul style="list-style-type: none"> ■ Ball and roller bearings in guide rollers for baking machinery ■ Kiln trucks and chemical plant ■ Piston pins in compressors 	-30	+260	+200
Special requirements	SPEED2,6	<ul style="list-style-type: none"> ■ Ball bearings in machine tools ■ Spindle bearings ■ Rotary table bearings ■ Instrument bearings 	-40	+120	+80
	VIB3	<ul style="list-style-type: none"> ■ Ball and roller bearings in rotors for wind turbines (blade adjustment) ■ Packaging machinery ■ Rail vehicles 	-30	+150	+90
	FOOD2	<ul style="list-style-type: none"> ■ Ball and roller bearings in applications with food contact (NSF-H1 registration, kosher and halal certification) 	-30	+120	+70
	CLEAN-M	<ul style="list-style-type: none"> ■ Ball, roller and needle roller bearings as well as linear guidance systems in clean room applications 	-30	+180	+90
	MOTION2	<ul style="list-style-type: none"> ■ Ball and roller bearings in oscillating operation ■ Slewing rings in wind turbines 	-40	+130	+75



Thickener	Base oil	Consistency NLGI	Base oil viscosity at +40 °C mm ² /s	Tempera- tures		Low friction, high speed	High load, low speed	Vibra- tions	Support for seals	Relubri- cation facility
				Low	High					
Polycarbamide	Partially synthetic oil	3	148	+++	++	+	+	+	++	++
Lithium complex soap	Partially synthetic oil	2	130	+++	+++	++	+	+	+	+
Polycarbamide	Alkoxyfluoro oil	2	400	++	+++	-	+++	+	++	+
PTFE	Fluoridated polyether oil	2	550	++	+++	--	++	+	+	+
Lithium complex soap	Synthetic oil	2 – 3	25	+++	+	+++	--	-	+	+
Lithium complex soap	Mineral oil	3	170	++	++	-	++	+++	++	-
Aluminium complex soap	Synthetic oil	2	150	++	-	+	+	+	+	+++
Polycarbamide	Ester	2	103	+++	+++	+	+	+	+	++
Lithium soap	Synthetic oil	2	50	+++	+	-	++	+++	++	+

continued ▲

Available containers

 Grease container sizes

Arcanol grease ¹⁾	Tube		Cartridge	Can	Bucket		Hobbock		Drum
	70 g	250 g	400 g	1 kg	5 kg	12,5 kg	25 kg	50 kg	180 kg
MULTITOP	-	●	●	●	●	●	●	-	●
MULTI2	-	●	●	●	●	●	●	-	●
MULTI3	-	●	●	●	●	●	-	-	●
LOAD150	-	-	●	●	-	●	-	●	-
LOAD220	-	-	●	●	-	●	●	-	●
LOAD400	-	-	●	●	●	●	●	●	●
LOAD460	-	-	●	●	●	●	-	●	●
LOAD1000	-	-	-	-	●	-	●	●	●
TEMP90	-	-	●	●	●	-	●	-	●
TEMP110	-	-	●	●	-	-	-	●	-
TEMP120	-	-	●	●	●	-	●	-	-
TEMP200	●	-	-	●	-	-	-	-	-
SPEED2,6	-	●	●	●	-	-	●	-	-
VIB3	-	-	●	●	●	-	●	●	-
FOOD2	-	-	●	●	-	●	●	-	-
CLEAN-M	-	●	●	●	-	-	-	-	-
MOTION2	-	●	●	●	●	●	●	●	-

¹⁾ Other containers are available by agreement.



7 Bearing data

7.1 Main dimensions



The main dimensions are the key dimensions of a rolling bearing. They include ▶97|☐1:

- the bore diameter (d)
- the outside diameter (D)
- the width or height (B , C , T or H)
- the chamfer dimensions (r).



Main dimensions

- ① Deep groove ball bearing (radial bearing)
- ② Axial deep groove ball bearing (axial bearing)

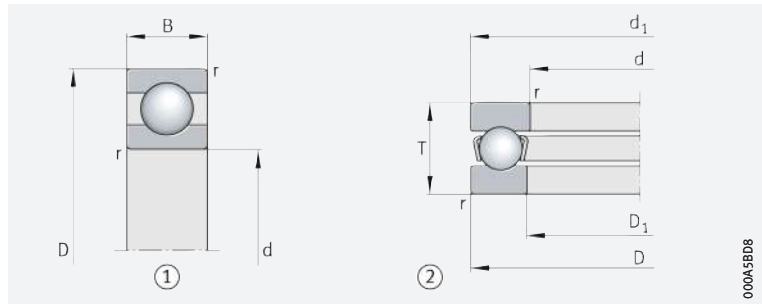

Standardised and non-standardised dimensions

☞ External dimensions are standardised

The dimensions which determine the installation space are standardised. Standardisation is not, however, applied to the internal dimensions, such as the size and quantity of the rolling elements for example. The main dimensions of metric rolling bearings are defined in the following ISO dimension plans:

- ISO 15:2017 for radial rolling bearings, excluding single row needle roller bearings, insert bearings and tapered roller bearings
- ISO 355:2007 for tapered roller bearings
- ISO 104:2015 for axial bearings.



DIN 616 describes dimension plans for radial and axial bearings. An overview of ISO and DIN rolling bearing standards is given in DIN 611:2010-05.

ISO dimension plans

☞ Standard dimensions

Experience has shown that the predominant proportion of all bearing arrangement tasks can be fulfilled using bearings with standard dimensions, which are contained in ISO dimension plans.

☞ Advantages of dimension plans

The dimension plans are valid for different bearing types. Standard rolling bearings of different types can thus be manufactured to the same external dimensions. As a result, a designer working on the same design envelope can make a selection between bearings of several types with the same external dimensions.



☞ Several outside diameters/width dimensions are assigned to one bearing bore

In the dimension plans, one bearing bore is allocated several outside diameters and width dimensions ▶102|☐10. In this way, it is possible to design several bearings of the same type that, for the same bore, exhibit different load carrying capacities. The development of new bearing series and individual new rolling bearings in accordance with the dimension plans has considerable advantages for users and manufacturers.

Bearing series are described using numbers

Width and diameter series

Width and diameter series are described using numbers. In the case of radial bearings in accordance with DIN 616 and ISO 15, these are as follows:

- for width series, the numbers 8, 9, 0, 1, 2, 3, 4, 5, 6, 7 ➤ 98| 2
- for the identification of diameter series, the numbers 7, 8, 9, 0, 1, 2, 3, 4, 5 ➤ 98| 3.



Identification of width series

For radial bearings to DIN 616 and ISO 15

① Width series

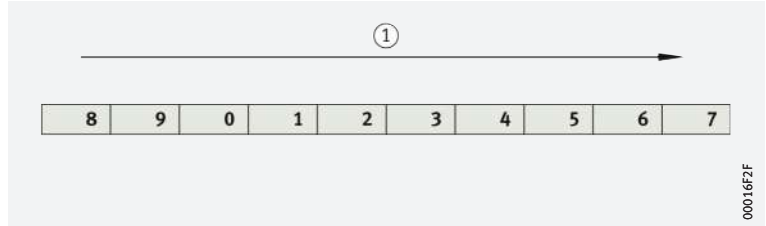

00016FZF



Identification of diameter series

For radial bearings to DIN 616 and ISO 15

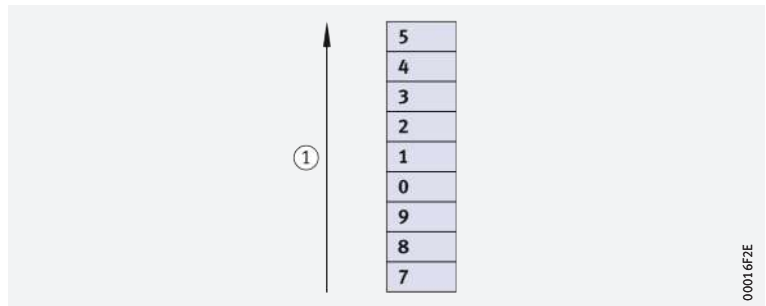

① Diameter series



00016FZE

The dimension series is created from the width series and the diameter series

Dimension series

The specific number of the width and diameter series, when combined, identifies the dimension series ➤ 98| 1. When this table is used, for example, for a radial bearing of the width series 2 and the diameter series 3, this gives the dimension series 23 ➤ 98| 1 and ➤ 99| 4. If the bearing bore code is then added, ➤ 103|7.3, the bearing size is completely defined.



Dimension series for radial bearings (excluding tapered roller and needle roller bearings)

		Width series – increase in cross-sectional width									
		8	9	0	1	2	3	4	5	6	7
Diameter series – increase in cross-sectional height	5	–	–	–	–	–	–	–	–	–	–
	4	–	–	04	–	24	–	–	–	–	–
	3	83	–	03	12	23	33	–	–	–	–
	2	82	–	02	12	22	32	42	52	62	–
	1	–	–	01	11	21	31	41	51	61	–
	0	–	–	00	10	20	30	40	50	60	–
	9	–	–	09	19	29	39	49	59	69	–
	8	–	–	08	18	28	38	48	58	68	–
	7	–	–	–	17	27	37	47	–	–	–



4
Generation
of the dimension series

- ① Width series
- ② Diameter series
- ③ Dimension series

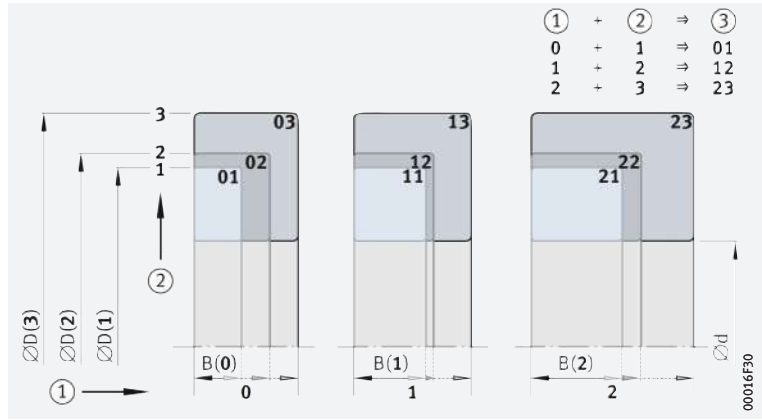

Dimension plan for metric tapered roller bearings to ISO 355



Tapered roller bearings can generally also be classified in the dimension plans to ISO 355 ▶99| 5. The dimension series are designated in these by a combination of three symbols, e.g. 3FE ▶99| 5.

5
Dimension plan for tapered
roller bearings (excerpt)
to ISO 355

- ① Contact angle series
(range of contact angles)
- ② Diameter series
- ③ Width series

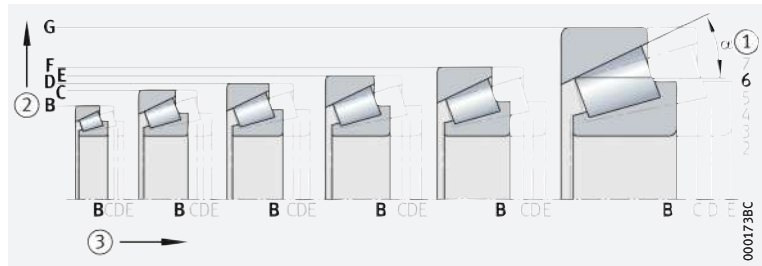

7.2 Designation system

Clear designation

Each rolling bearing has a designation that clearly indicates the type, dimensions, tolerances and internal clearance, if necessary with other important features.

Interchangeability

Bearings that have the same standardised designation are interchangeable with each other. In the case of separable bearings, it cannot always be ensured that individual parts with the same origin can be interchanged with each other.



In Germany, the bearing designations are standardised in DIN 623-1. These designations are also used in many other countries.

Designation

The designation is a code comprising numbers and letters

The designation for the bearing series comprises numbers and letters and, in many cases, the diameter series too ▶100| 6, ▶100| 7 and ▶102| 10. The diameter and width series are described in ▶97|7.1.

Basic designation, prefix and suffix

Basic designation

The basic designation contains the symbols for the bearing series and the bearing bore ▶100| 6, ▶100| 7 and ▶102| 10.

Prefix

The prefix normally identifies individual bearing parts of complete bearings (in certain cases, this may also be part of the basic designation) ▶100| 6 and ▶100| 7.

Suffix

The suffix defines special designs and features ▶100| 6 and ▶100| 7. The prefix and suffix describe other features of the bearing but are not standardised in all cases and may vary in use depending on the manufacturer.

Designations – examples

Examples of the composition of designations on the basis of their definition in accordance with ►101|6 are shown on ►101|7.

6
 Composition of designations

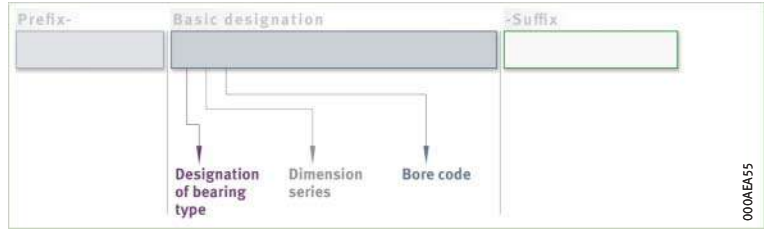

7
 Examples of bearing designations, constructed in accordance with ►6

- ① Spherical roller bearing
- ② Deep groove ball bearing
- ③ Axial cylindrical roller bearing

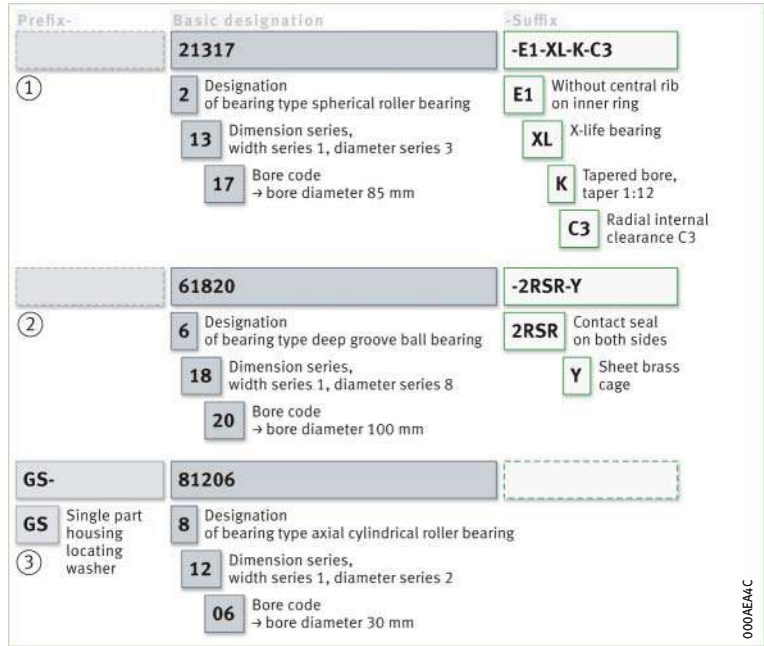

Designations of metric tapered roller bearings according to ISO 355 and ISO 10317

Structure of bearing designation for metric tapered roller bearings

►101|8 describes as an example the structure of the designation for a metric tapered roller bearing (dimension series to ISO 355, designation to ISO 10317). The 3 indicates the contact angle range. The first letter (F in this case) indicates a diameter series. Each diameter series has a certain ratio D/d (outside diameter to bore diameter). The second letter (E in this case) indicates a width series. Each width series has a certain ratio of bearing width T to the height of the bearing cross-section. The addition of the letter T (for tapered roller bearing) at the start and a three-digit number at the end for the bearing bore diameter in mm (in this case 120) gives the complete designation of a tapered roller bearing (e.g. T3FE 120 ►101|8).



DIN 720 Appendix 1 gives an interchange table for DIN and ISO designations.



8

Composition of designation for metric tapered roller bearings to ISO 10317

Dimension series to ISO 355, designation to ISO 10317

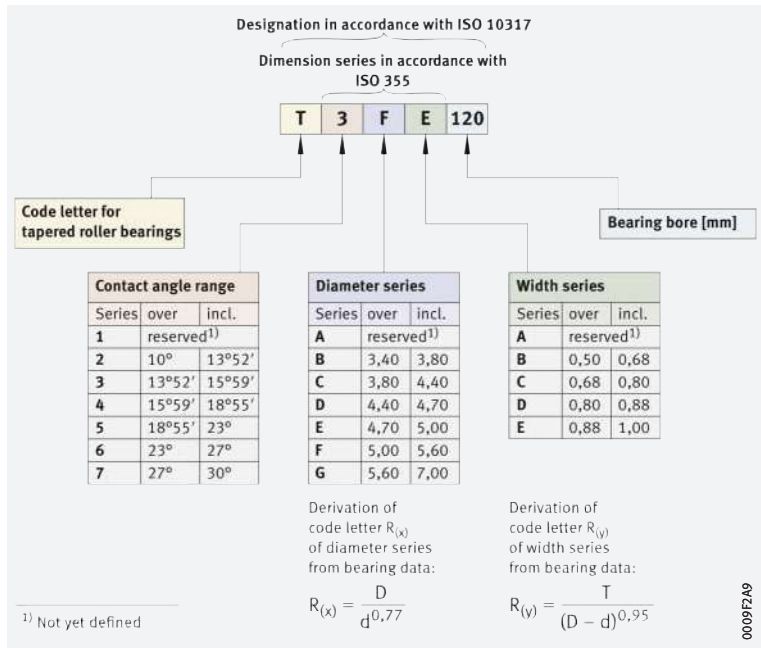

9

Example designation for metric tapered roller bearings to DIN 720

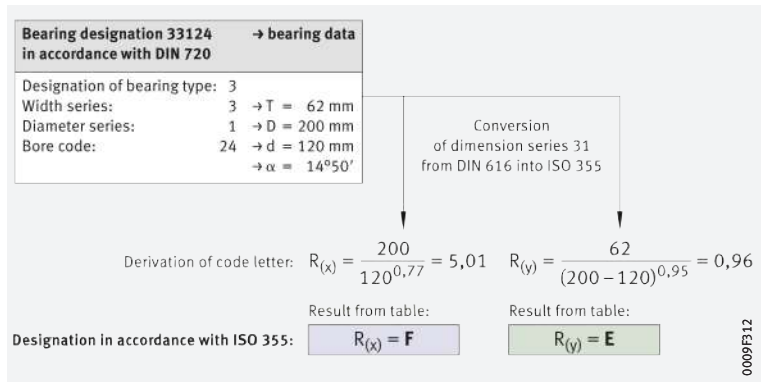

10 Bearing designations in accordance with DIN 623-1:1993 – basic designation structure

The bore code is derived from the diameter d of the bearing bore: with a factor of 5 or the addition of an oblique

d ≤ 9 mm										/+d = bore code												
Bore code	/0,6	1	/1,5	2	/2,5	3	4	5	6	7	8	9										
Bearing bore d	0,6	1	1,5	2	2,5	3	4	5	6	7	8	9										

10 mm ≤ d ≤ 32 mm										d calculated by different means												
Bore code	00	01	02	03	04	/22	05	/28	06	/32												
Bearing bore d	10	12	15	17	20	22	25	28	30	32												

35 mm ≤ d < 500 mm										d = 5 · bore code												
Bore code	07	08	09	10	11	12	...	80	84	88	92	96										
Bearing bore d	35	40	45	50	55	60	...	400	420	440	460	480										

d ≥ 500 mm										/+d = bore code												
Bore code	/500	/530	/560	/600	/630	/670	/710	/750	/800	/850	/900	...										
Bearing bore d	500	530	560	600	630	670	710	750	800	850	900	...										

Basic designation

Bearing series
Bore code

Dimension series

Diameter series
Series of various outside diameters D , which are assigned to each bore diameter d

Width series
For radial bearings: series of various bearing widths B , which are assigned to each bearing bore diameter d and each diameter series

Height series
For axial bearings: series of various bearing heights H , which are assigned to each bearing bore diameter d and each diameter series

Bearing type

	0	1	2	3	4	5	6	7	8	C	N	NN	QJ
Bearing series	(0)38 (0)30 (0)32 (0)33	1(0)0 1(0)2	238 248 239 249 1(0)3 (1)23	329 320 330 331 302 302	4(2)2 4(2)3	511 512 513 514 532 533	6(0)8 618 6(0)9 619 16(0)0 6(1)0	718 7(1)0 7(0)2 7(0)3 7(0)4	893 894 811 812	C39 C30 C40 C31 C41 C22 C32 C23	..19 ..10 ..(0)2 ..22 ..(0)3 ..23 ..(0)4	..48 ..49 ..30 ..41	QJ10 QJ(0)2 QJ(0)3
Bearing type	Double row angular contact ball bearing	Self-aligning ball bearing	Spherical roller bearing, barrel roller bearing, axial spherical roller bearing	Tapered roller bearing	Double row deep groove ball bearing	Axial deep groove ball bearing	Single row deep groove ball bearing	Single row angular contact ball bearing	Axial cylindrical roller bearing	Toroidal roller bearing	Single row cylindrical roller bearing	Double row cylindrical roller bearing	Four point contact bearing

000AE93A



7.3 Determining the bearing bore

For $d < 10$ mm, the bore diameter is stated in the basic designation

For certain bearing types, the bearing bores are stated directly or in an encoded form in accordance with DIN 623-1. Up to $d < 10$ mm, the bearing bore diameter is specified in the dimension-specific part of the designation (basic designation) directly as a number indicating the diameter ▶ 102 | 10.

Example Deep groove ball bearing 623, bore diameter = 3 mm.

Bore code

The bore code describes the bearing bore from $d \geq 10$ mm

For nominal dimensions $d \geq 10$ mm to $d < 500$ mm, the diameter is described by means of a bore code ▶ 102 | 10.

For bores from 10 mm to 17 mm, the following applies:

$d = 10$ mm, bore code 00

$d = 12$ mm, bore code 01

$d = 15$ mm, bore code 02

$d = 17$ mm, bore code 03.



For all rolling bearings in the range from $d = 20$ mm to $d = 480$ mm (excluding double direction axial bearings), the bore code is formed by dividing the dimension of the bearing bore by 5.

Example Bearing bore $d = 360$ mm divided by 5 ($360 : 5$), bore code = 72.

From $d > 480$ mm

From $d > 480$ mm, the unencoded bore diameter is given with an oblique after the bearing series, e.g. 618/500 with bore diameter $d = 500$ mm.

Intermediate sizes

The intermediate sizes, such as bore diameter $d = 22$, 28 and $d = 32$ mm for example, are also given with an oblique as /22, /28 and /32.

Magneto bearings

In the case of magneto bearings, the unencoded nominal bore dimension is given.

7.4 Radial internal clearance

The radial internal clearance is determined on the dismounted bearing

The radial internal clearance applies to bearings with an inner ring and is determined on the unmounted bearing. It is defined as the amount by which the inner ring can be moved in a radial direction from one extreme position to the other in relation to the outer ring ▶ 103 | 11.



The radial internal clearance groups are defined in DIN 620-4 and ISO 5753-1 and are described in DIN 620-4 by means of codes that comprise the capital letter C and a number. ISO 5753-1 designates the groups by the word "Group" and a number ▶ 103 | 11 and ▶ 104 | 2.



Internal clearance groups

C2, CN, C3, C4, C5 = radial internal clearance groups according to DIN 620-4

Group 2, N, 3, 4, 5 = radial internal clearance groups according to ISO 5753-1

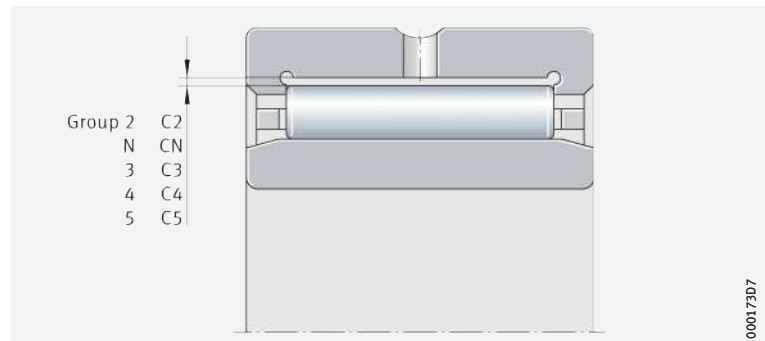

2
 Radial internal clearance groups

Internal clearance group		Description	Application
DIN 620-4	ISO 5753-1		
C2	Group 2	Internal clearance < CN	For heavy alternating loads combined with swivel motion
CN	Group N	Normal internal clearance, CN is not included in bearing designations	For normal operating conditions with shaft and housing tolerances
C3	Group 3	Internal clearance > CN	For bearing rings with press fits and large temperature differential between the inner and outer ring
C4	Group 4	Internal clearance > C3	
C5	Group 5	Internal clearance > C4	

Enveloping circle For bearings without an inner ring, the enveloping circle F_w is used. This is the inner inscribed circle of the rolling elements in clearance-free contact with the outer raceway **104** | **12**.

12
 Enveloping circle

F_w = enveloping circle diameter

- ① Rolling element
- ② Outer raceway

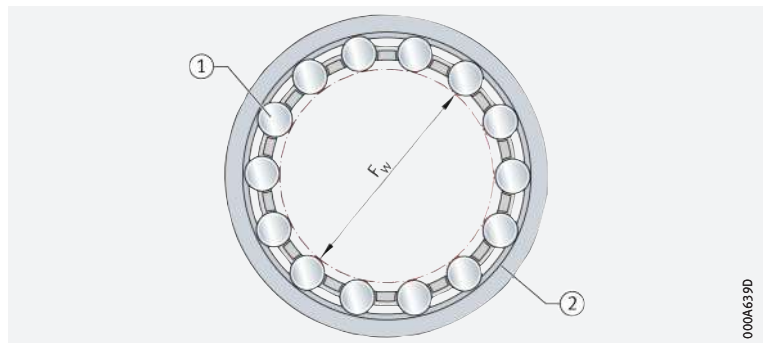

7.5 Operating clearance

The operating clearance is determined on a bearing still warm from operation

A normal operating clearance is usually achieved with internal bearing clearance CN

The operating clearance is determined on a mounted bearing still warm from operation. It is defined as the amount by which the shaft can be moved in a radial direction from one extreme position to the other. The operating clearance is derived from the radial internal clearance and the change in the radial internal clearance as a result of interference fit and thermal influences in the mounted condition.

The operating clearance value is dependent on the operating and installation conditions of the bearing. A larger operating clearance is, for example, necessary if heat is transferred via the shaft, the shaft undergoes deflection or if misalignment occurs. An operating clearance smaller than CN should only be used in special cases, for example in high precision bearing arrangements. Normal operating clearance is achieved with an internal clearance of CN or, for larger bearings, more usually C3 if the recommended shaft and housing tolerances are maintained.

Calculation of operating clearance

The operating clearance is determined in accordance with **104** | **1**.

1
 Operating clearance

Legend

$$s = s_r - \Delta s_p - \Delta s_T$$

s	μm	Radial operating clearance of mounted bearing warm from operation
s_r	μm	Radial internal clearance
Δs_p	μm	Reduction in radial internal clearance due to fit
Δs_T	μm	Reduction in radial internal clearance due to temperature.



Reduction in radial internal clearance due to fit

The radial internal clearance is reduced due to the fit as a result of expansion of the inner ring and contraction of the outer ring ► 105 | f.2.

f.2
Reduction in radial internal clearance

$$\Delta s_p = \Delta d + \Delta D$$

Legend

Δs_p	μm	Reduction in radial internal clearance due to fit
Δd	μm	Expansion of the inner ring
ΔD	μm	Contraction of the outer ring.

The expansion of the inner ring is calculated in accordance with ► 105 | f.3.

f.3
Expansion of the inner ring

$$\Delta d \approx 0,9 \cdot U \cdot d/F \approx 0,8 \cdot U$$

Legend

d	mm	Bore diameter of the inner ring
U	μm	Theoretical interference of the fitted parts with firm seating. The theoretical oversize of the fitted parts with a firm seating is determined from the mean deviations and the upper and lower deviations of the tolerance zones of the fitted parts reduced by $1/3$ of their acceptable value. The amount of surface smoothing during assembly must be subtracted from this.
F	mm	Raceway diameter of the inner ring.



For very thin-walled housings and light metal housings, the reduction in the radial internal clearance must be determined by mounting trials. The contraction of the outer ring is calculated in accordance with ► 105 | f.4.

f.4
Contraction of the outer ring

$$\Delta D \approx 0,8 \cdot U \cdot E/D \approx 0,7 \cdot U$$

Legend

ΔD	μm	Contraction of the outer ring
E	mm	Raceway diameter of the outer ring
D	mm	Outside diameter of the outer ring.

Reduction in radial internal clearance due to temperature

The radial internal clearance can alter considerably if there is a substantial temperature differential between the inner and outer ring ► 105 | f.5.

f.5
Reduction in radial internal clearance due to temperature

$$\Delta s_T = \alpha \cdot d_M \cdot 1\,000 \cdot (\vartheta_{IR} - \vartheta_{AR})$$

Legend

Δs_T	μm	Reduction in radial internal clearance due to temperature
α	K^{-1}	Coefficient of thermal expansion of steel: $\alpha = 0,000011 \text{ K}^{-1}$
d_M	mm	Mean bearing diameter $(d + D)/2$
ϑ_{IR}	$^{\circ}\text{C}, \text{K}$	Temperature of the inner ring
ϑ_{AR}	$^{\circ}\text{C}, \text{K}$	Temperature of the outer ring (usual temperature difference between inner and outer ring: 5 K to 10 K).



A larger radial internal clearance should be used for shafts running at high speeds, since adequate thermal compensation between the bearing, shaft and housing does not occur in this situation. Δs_T can, in this case, be significantly higher in this case than for continuous operation.

7.6 Axial internal clearance

The axial internal clearance s_a is defined as the amount by which one bearing ring can be moved relative to the other, without load, along the bearing axis ▶106|📐13.

📐13 Axial internal clearance in comparison with radial internal clearance

s_a = axial internal clearance
 s_r = radial internal clearance

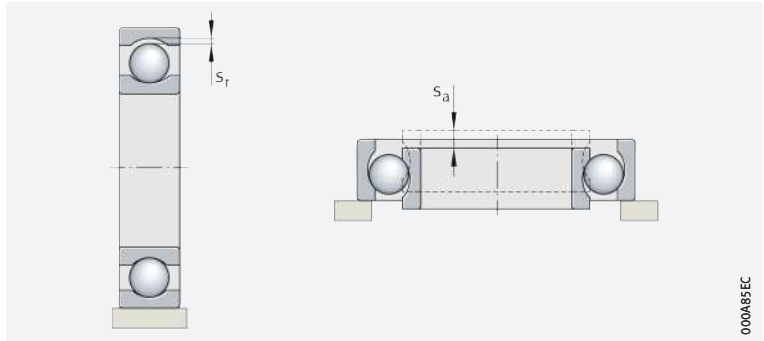

🔗 Relationship between radial and axial internal clearance

With various bearing types, the radial internal clearance s_r and the axial internal clearance s_a are dependent on each other. Guide values for the correlation between radial and axial internal clearance are shown for some bearing types ▶106|📊3.

📊3 Correlation between axial internal clearance and radial internal clearance

Bearing type		Ratio between axial and radial internal clearance s_a/s_r
Self-aligning ball bearings		$2,3 \cdot Y_0^1$
Spherical roller bearings		$2,3 \cdot Y_0^1$
Tapered roller bearings	Single row, arranged in pairs	$4,6 \cdot Y_0^1$
	Matched pairs (N11CA)	$2,3 \cdot Y_0^1$
Angular contact ball bearings	Double row, series 32 and 33	1,4
	Double row, series 32..-B and 33..-B	2
Four point contact bearings		1,4

¹⁾ Y_0 = axial load factor in accordance with product table.



If the operating clearance is an important design criterion, please consult Schaeffler.



The calculation module BEARINX-online Shaft Calculation, which is available from Schaeffler free of charge, can be used to calculate and analyse the operating clearance.

Calculation example

🔗 Example: deep groove ball bearing 6008-C3

For deep groove ball bearings, the calculation of the axial internal clearance is shown in the following example:

Deep groove ball bearing	6008-C3
Bore diameter d	40 mm
Radial internal clearance before fitting	15 μm to 33 μm
Actual radial internal clearance	24 μm
Mounting tolerance Shaft	k5
Housing	J6
Reduction in radial internal clearance during fitting	14 μm
Radial internal clearance after fitting	24 μm - 14 μm = 10 μm
Ratio s_a/s_r ▶107 📐14	13

🔗 Axial internal clearance

$$s_a = 13 \cdot 10 \mu\text{m} = 130 \mu\text{m}.$$



14

Approximate calculation of the ratio of radial to axial internal clearance for deep groove ball bearings

s_a = axial internal clearance
 s_r = radial internal clearance
 d = bearing bore diameter

① Bearing series

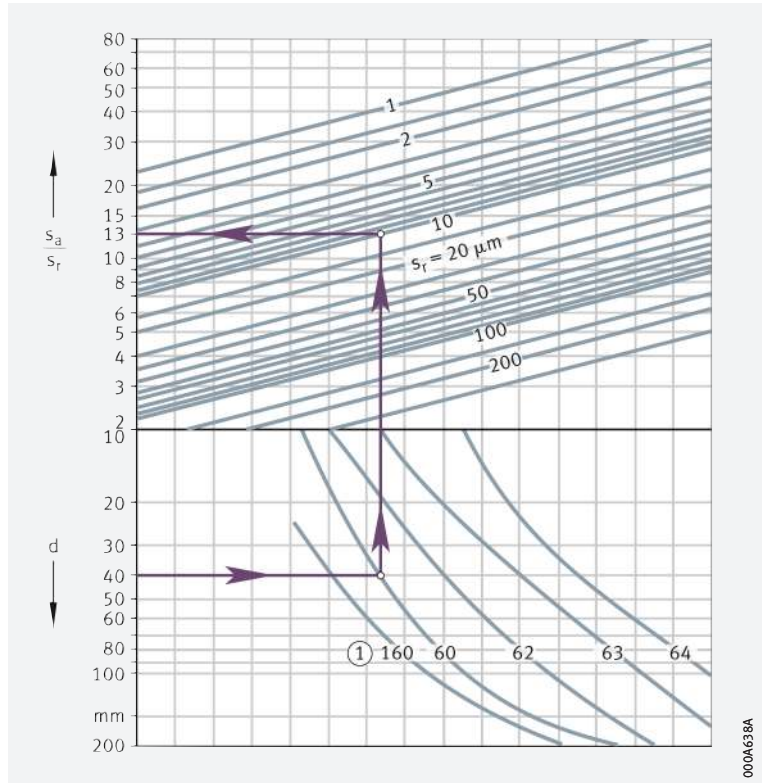

0004638A

7.7

Bearing materials

Standard steels

Schaeffler rolling bearings fulfil the requirements for fatigue strength, wear resistance, hardness, toughness and structural stability. The material used for the rings and rolling elements is generally a low-alloy, through hardening chromium steel of high purity. For bearings subjected to considerable shock loads and reversed bending stresses, case hardening steel is also used (supplied by agreement). The results of research as well as practical experience confirm that bearings made from the steel currently used as standard can achieve their endurance limit if loads are not excessively high and the lubrication and cleanliness conditions are favourable.

For the most challenging conditions

High Nitrogen Steel

Through the use of special bearings made from HNS (High Nitrogen Steel, supplied by agreement), it is possible to achieve adequate service life even under the most challenging conditions (high temperatures, moisture, contamination).

Steels for increased requirements

High performance steels Cronidur and Cronitect

For increased performance requirements, highly corrosion-resistant, nitrogen-alloyed martensitic HNS steels are available, such as Cronidur and Cronitect.

In contrast to Cronidur, the more economical alternative Cronitect has nitrogen introduced into the structure by means of a surface layer hardening process.

Both steels are clearly superior to conventional corrosion-resistant steels for rolling bearings in terms of corrosion resistance and fatigue strength.

Hybrid bearings

Ceramic materials

Ceramic hybrid spindle bearings contain balls made from silicon nitride. These ceramic balls are substantially lighter than steel balls. The centrifugal forces and friction are significantly lower.

Hybrid bearings allow very high speeds, even with grease lubrication, as well as long operating life and low operating temperatures.

Materials and bearing components

Suitable materials and their use in rolling bearing technology ► 108 | 4.

4
 Materials and bearing components

Material	Bearing components (example)
Through hardening chromium steel – rolling bearing steel in accordance with ISO 683-17	Outer and inner ring, axial washer
HNS – High Nitrogen Steel	Outer and inner ring
Corrosion-resistant steel – rolling bearing steel in accordance with ISO 683-17	Outer and inner ring
Case hardening steel	For example, outer ring of yoke type track rollers
Flame or induction hardening steel	Roller stud of stud type track rollers
Steel strip to EN 10139, SAE J403	Outer ring for drawn cup needle roller bearings
Silicon nitride	Ceramic balls
Brass alloy	Cage
Aluminium alloy	Cage
Polyamide (thermoplastic)	Cage
NBR, FKM, TPU	Sealing ring



Corrosion protection by Corrotect

! Rolling bearings are not resistant to corrosion by water or agents containing alkalis or acids but are often exposed to these corrosion-inducing agents. In these applications, corrosion protection is therefore a decisive factor in achieving a long operating life of the bearings.

DIN ISO In principle, corrosion-resistant steels to ISO 683-17 can be used. These bearings have the prefix S. For higher requirements, it may be advisable to use the high performance steels Cronidur and Cronitect.

Corrotect coating

Special coatings An extensive modular coating concept currently offers a wide range of surface improvements aimed at increasing the performance and rating life of bearing components. The “added value in the form of coatings” thus provided, is now established as a standard procedure for a wide variety of Schaeffler components.

Various coating variants and coating thicknesses Thin anti-corrosion coating systems of 0,5 µm – 3 µm and 2 µm – 5 µm are available for bearing applications. Various Corrotect variants with coating thicknesses > 5 µm also exist, which can be applied as necessary. The Corrotect coatings thus offer corrosion protection times – as a function of the coating variant and coating thickness – of ≥ 720 h against base metal corrosion (in accordance with DIN EN ISO 9227).

Cr(VI)-free coatings Systems are free from Cr(VI), provide effective protection against corrosion and, as result, extend the useful life of Schaeffler components. In isolated cases, the dimensional changes brought about by the coating must be taken into account in a further processing operation.

📖 Detailed information on the modular coating concept and individual coating systems can be found in Technical Product Information **►** **□ TPI 186** “Higher Performance Capacity Through the Use of Coatings”. This publication can be requested from Schaeffler.

Advantages of Corrotect thin coating The advantages of the special coating Corrotect are all-round corrosion protection, including the turned surfaces of chamfers and radi **► 109 | □ 15**. It also gives long-term prevention of rust penetration beneath seals and smaller bright spots are protected against corrosion by the cathodic protection effect. In comparison with uncoated parts, operating life is significantly increased by the corrosion protection. There is no decrease in load carrying capacity (such as occurs in the use of corrosion-resistant steels). It is therefore theoretically possible to replace uncoated bearings by coated bearings of the same dimensions. However, it is advisable to check the suitability for the specific application in advance since, for example, abrasion may occur. During storage, there is no need to use organic preservatives.

Mounting of Corrotect-coated bearings

! Before bearings with Corrotect coating are mounted, compatibility with the media should always be checked.

For lower press-in forces, the surface of the parts should be lightly greased, the tolerances are increased by the thickness of the coating.

□ 15

Coated and uncoated part after a salt spray test

Test time 24 h in salt spray

- ① With Corrotect coating
- ② Uncoated



7.8 Cages

The functions of cages

☞ *Cage is a retainer with pockets for the rolling elements*

Cage pockets, which are separated from each other by bars and are uniformly distributed around the circumference of the cage, maintain the spacing of the rolling elements relative to each other and ensure the distribution of load. In addition, the bars prevent sliding friction between adjacent rolling elements and guide the rolling elements parallel to the bearing axis in the load-free zone. In the case of cylindrical and needle roller bearings, they additionally prevent skewing of the rolling elements by guiding the rolling elements parallel to the bearing axis.

☞ *Cages ensure spacing between the rolling elements, even in the load-free zone*

In the load-free zone, the rolling elements are no longer driven by the inner or outer ring. As a result, they fall behind relative to the direction of rotation of the rings. Cages ensure that the spacing between the rolling elements is maintained, even in the load-free zone.

☞ *Where bearings are separable and can be swivelled, the rolling elements cannot escape from the bearing*

In the case of bearings that are separable and can be swivelled, such as tapered roller, spherical roller and some cylindrical roller bearings, cages prevent rolling elements from falling out of the bearing. The rolling element set and cage can thus be mounted and dismounted as a complete unit.

Sheet metal or solid cages

☞ *Sheet metal cages*

Rolling bearing cages are subdivided into sheet metal and solid cages. The cages are predominantly made from steel and, for some bearings, from brass ► 111 | ☞ 16. In comparison with solid cages made from metal, sheet metal cages are of lower mass. Since a sheet metal cage only fills a small proportion of the gap between the inner and outer ring, lubricant can easily reach the interior of the bearing and is held on the cage. In general, a sheet steel cage is only included in the bearing designation if it is not defined as a standard version of the bearing.

☞ *Solid cages*

These cages are made from metal, laminated fabric or plastic ► 111 | ☞ 17. They can be identified from the bearing designation.

☞ *Solid cages made from metal or laminated fabric*

Solid cages made from metal are used where there are requirements for high cage strength and at high temperatures. Solid cages are also used if the cage must be guided on ribs. Rib-guided cages for bearings running at high speeds are made in many cases from light materials, such as light metal or laminated fabric, in order to achieve low inertia forces.

☞ *Solid cages made from polyamide PA66*

Solid cages made from polyamide PA66 are produced using the injection moulding process ► 111 | ☞ 18. As a result, cage types can generally be realised that allow designs with particularly high load carrying capacity. The elasticity and low mass of polyamide are favourable under shock type bearing loads, high accelerations and decelerations and tilting of the bearing rings in relation to each other. Polyamide cages have very good sliding and emergency running characteristics.



Cages made from glass fibre reinforced polyamide PA66 are suitable for continuous temperatures up to +120 °C. For higher operating temperatures, plastics such as PA46 or PEEK can be used.



When using oil lubrication, additives in the oil can impair the cage operating life. Aged oil can also impair the cage operating life at high temperatures, so attention must be paid to compliance with the oil change intervals.



Cage designs

Proven cage designs ► 111 |  16 to ► 111 |  18.

16 Sheet steel cages

- ① Riveted cage for deep groove ball bearings
- ② Window cage for needle roller bearings
- ③ Window cage for spherical roller bearings



00048E70

17 Solid brass cages

- ① Riveted solid cage for deep groove ball bearings
- ② Window cage for angular contact ball bearings
- ③ Riveted cage with crosspiece rivets for cylindrical roller bearings



00016FF0

18 Solid cages made from glass fibre reinforced polyamide

- ① Window cage for single row angular contact ball bearings
- ② Window cage for cylindrical roller bearings
- ③ Window cage for needle roller bearings



0001701A

The cages are guided by rolling elements or ribs

Standard cages are suitable under normal operating conditions

Guidance of cages

A further means of distinguishing between cages is their guidance method ► 112 | 19. Most cages are guided by the rolling elements and do not have a suffix for the guidance method. If guidance is by the bearing outer ring, the suffix A is used. Cages that are guided on the inner ring have the suffix B.

Under normal operating conditions, the cage design defined as the standard cage is generally suitable. Standard cages, which may differ within a bearing series according to the bearing size, are described in the product chapters. Under special operating conditions, a cage that is suitable for the specific conditions must be selected.

19 Guidance of cages

- ① Guided by rolling elements
- ② Guided by ribs

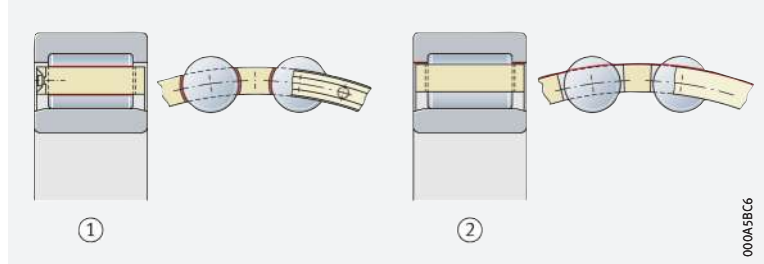

7.9 Operating temperature

Standard rolling bearings can be used up to +120 °C

Rolling bearings are heat treated such that, depending on the bearing type, they are generally dimensionally stable up to +120 °C (certain bearings up to +150 °C). Operating temperatures above +150 °C require special heat treatment. Bearings treated in this way are available by agreement and are identified by the suffix S1, S2, S3 or S4 to DIN 623-1 ► 112 | 5.



Above S1, there is a reduction in hardness that must be taken into consideration in the rating life calculation.

5 Operating temperature and suffixes for dimensionally stabilised bearings

¹⁾ Inner ring and outer ring stabilised for stated operating temperature

²⁾ Inner ring stabilised up to +150 °C

Maximum operating temperature °C	Suffix for dimensionally stabilised bearings
+120	SN ¹⁾ (suffix SN not stated)
+150	S0 ¹⁾
+150	S0B ²⁾ (suffix B not stated)
+200	S1 ¹⁾
+250	S2 ¹⁾
+300	S3 ¹⁾
+350	S4 ¹⁾

Track rollers

Normal operating temperature = +70 °C

An operating temperature of +70 °C is regarded as a normal operating temperature. Further temperature data in the product descriptions must be observed.



Sealed bearings

Temperature limits

The permissible temperature for sealed bearings is dependent on the requirements for the operating life of the grease filling and on the action of the contact seals. Sealed bearings are greased with specially tested, high performance, high quality greases. These greases can withstand +120 °C for short periods. At or above continuous temperatures of +70 °C, a reduction in the operating life of standard greases with a lithium soap base must be expected.

Special greases are often required for high temperatures

In many cases, adequate operating life values are only achieved at high temperatures through the use of special greases. In these cases, it must also be checked whether seals made from especially heat-resistant materials must be used. The operating limit of normal contact seals is +100 °C.



If high temperature synthetic materials are used for seals and greases, it must be noted that the particularly high performance materials containing fluoride may give off harmful gases and vapours when heated to approx. +300 °C and above. This may occur, for example, if a welding torch is used in the dismantling of a bearing.

Observe safety data sheets at high temperatures

High temperatures are critical especially in the case of seals made from fluoro rubber (FKM, FPM, e.g. Viton®) or greases containing fluoride, such as the rolling bearing greases Arcanol TEMP200 and greases to GA11. If high temperatures are unavoidable, attention must be paid to the valid safety data sheet for the specific fluoride-containing material, which can be obtained upon request.

7.10 Dimensional and running tolerances



International standards are usually valid for the main dimensions and running accuracy of rolling bearings. Unless specified otherwise, the tolerances for radial rolling bearings correspond to ISO 492:2014 and, for axial rolling bearings, to ISO 199:2014. Information on which bearings are supplied with which tolerances is provided in the relevant product chapters.

Main dimensions Main dimensions of bearings ► 114 | 20.

20
 Main dimensions of bearings

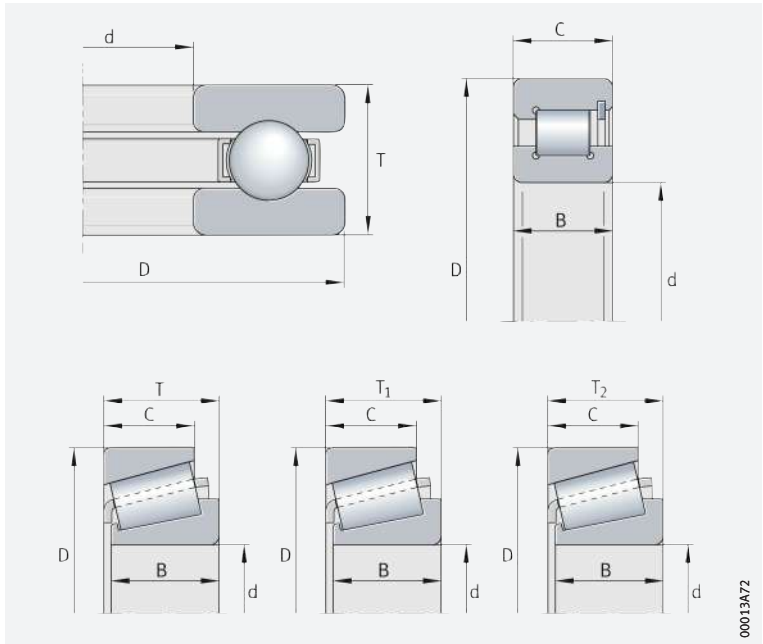

00013A72

Accuracy (tolerance classes)

Tolerance class Normal

The dimensional and running accuracy of rolling bearings corresponds to tolerance class Normal. For bearings with increased accuracy, the tolerances are restricted to values in the classes 6, 5, 4 and 2. Tolerance tables for the individual tolerance classes ► 122 | 8 to ► 135 | 28.

Super precision bearings

In addition to the standardised tolerance classes, super precision bearings are also produced to the tolerance classes P4S, SP and UP. These tolerances are listed in the relevant product descriptions.

Tolerance symbols, tolerated characteristics, deviations for radial and axial rolling bearings





The following restrictions apply to the stated specification modifiers in ► 115 | 6 and ► 120 | 7:

- The specification modifier **(LP)** is not indicated on a drawing if the two-point size is defined as the default specification.
- The specification modifier **(GN)** is not suitable for cases where there is no material with mating contact, for example the outer ring of a tapered roller bearing with significant edge rounding on the back face and small front face. Solutions must be developed within the framework of the GPS system and taken into consideration in the future.



6

Symbols for nominal dimensions, characteristics and specification modifiers for radial rolling bearings in accordance with ISO 492:2014

Symbol for nominal dimension¹⁾2) Tolerance symbol for characteristic ²⁾	GPS symbol and specification modifier	Description for radial bearings	Old term
	Symbols in accordance with ISO 1101 and ISO 14405-1	In accordance with ISO 492:2014 (based on ISO 1101, ISO 5459 and ISO 14405-1)	In accordance with ISO 1132-1: 2000
Width			
B	–	Nominal inner ring width	Nominal inner ring width
$t_{\Delta Bs}$	LP	Symmetrical rings Deviation of a two-point size of inner ring width from its nominal size $\Delta Bs = Bs - B$ Bs = single two-point size of inner ring width	Deviation of a single inner ring width
	GNALS  LP	Asymmetrical rings, upper limit Deviation of a minimum circumscribed size of inner ring width, between two opposite lines, in any longitudinal section which includes the inner ring bore axis, from its nominal size Asymmetrical rings, lower limit Deviation of a two-point size of inner ring width from its nominal size	
t_{VBs}	LP SR	Symmetrical rings Range of two-point sizes of inner ring width $VBs = Bs_{max} - Bs_{min}$	Variation of inner ring width
	GNALS SR 	Asymmetrical rings Range of minimum circumscribed sizes of inner ring width, between two opposite lines, obtained from any longitudinal section which includes the inner ring bore axis	
C	–	Nominal outer ring width	Nominal outer ring width
$t_{\Delta Cs}$	LP	Symmetrical rings Deviation of a two-point size of outer ring width from its nominal size $\Delta Cs = Cs - C$ Cs = single two-point size of inner ring width	Deviation of a single outer ring width
	GNALS  LP	Asymmetrical rings, upper limit Deviation of a minimum circumscribed size of outer ring width, between two opposite lines, in any longitudinal section which includes the outer ring outside surface axis, from its nominal size Asymmetrical rings, lower limit Deviation of a two-point size of outer ring width from its nominal size	
			continued ▼

1) Symbols for the nominal dimension are printed in bold; they indicate size dimensions and spacings.

2) Symbols in accordance with ISO 15241 (exception: font).

6

Symbols for nominal dimensions, characteristics and specification modifiers for radial rolling bearings in accordance with ISO 492:2014

Symbol for nominal dimension ¹⁾²⁾ Tolerance symbol for characteristic ²⁾	GPS symbol and specification modifier	Description for radial bearings	Old term
	Symbols in accordance with ISO 1101 and ISO 14405-1	In accordance with ISO 492:2014 (based on ISO 1101, ISO 5459 and ISO 14405-1)	In accordance with ISO 1132-1:2000
t_{VCs}	$\textcircled{LP} \textcircled{SR}$	Symmetrical rings Range of two-point sizes of outer ring width $VCs = Cs_{max} - Cs_{min}$	Variation of outer ring width
	$\textcircled{GN} \textcircled{ALS} \textcircled{SR} \leftarrow \text{=}$	Asymmetrical rings Range of minimum circumscribed sizes of outer ring width, between two opposite lines, obtained from any longitudinal section which includes the outer ring outside surface axis	
C_1	–	Nominal outer ring flange width	Nominal outer ring flange width
$t_{\Delta C1s}$	\textcircled{LP}	Deviation of a two-point size of outer ring flange width from its nominal size	Deviation of a single outer ring flange width
t_{VC1s}	$\textcircled{LP} \textcircled{SR}$	Range of two-point sizes of outer ring flange width $VC1s = C1s_{max} - C1s_{min}$	Variation of outer ring flange width
Diameter			
d	–	Nominal bore diameter of a cylindrical bore or at the theoretical small end of a tapered bore	Nominal bore diameter
$t_{\Delta ds}$	\textcircled{LP}	Deviation of a two-point size of bore diameter from its nominal size $\Delta ds = ds - d$	Deviation of a single bore diameter
t_{Vdsp}	$\textcircled{LP} \textcircled{SR} \textcircled{ACS}$	Range of two-point sizes of bore diameter in any cross-section of a cylindrical or tapered bore $Vdsp = ds_{max} - ds_{min}$	Variation of bore diameter in a single plane
$t_{\Delta dmp}$	$\textcircled{LP} \textcircled{SD} \textcircled{ACS}$	Cylindrical bore Deviation of a mid-range size (out of two-point sizes) of bore diameter in any cross-section from its nominal size $dmp = (d_{max} + d_{min})/2$ $\Delta dmp = dmp - d$	Deviation of mean bore diameter in a single plane
	$\textcircled{LP} \textcircled{SD} \textcircled{SCS}$	Tapered bore Deviation of a mid-range size (out of two-point sizes) of bore diameter at the theoretical small end of a tapered bore from its nominal size	
			continued ▲▼

¹⁾ Symbols for the nominal dimension are printed in bold; they indicate size dimensions and spacings.
²⁾ Symbols in accordance with ISO 15241 (exception: font).



6

Symbols for nominal dimensions, characteristics and specification modifiers for radial rolling bearings in accordance with ISO 492:2014

Symbol for nominal dimension ¹⁾²⁾ Tolerance symbol for characteristic ²⁾	GPS symbol and specification modifier	Description for radial bearings	Old term
	Symbols in accordance with ISO 1101 and ISO 14405-1	In accordance with ISO 492:2014 (based on ISO 1101, ISO 5459 and ISO 14405-1)	In accordance with ISO 1132-1: 2000
t_{Vdmp}	ⓁⓅ ⓈⓉ Ⓜ ⓐ ⓐ Ⓢ Ⓢ Ⓡ	Range of mid-range sizes (out of two-point sizes) of bore diameter obtained from any cross-section of a cylindrical bore $Vdmp = dmp \text{ max} - dmp \text{ min}$	Variation of mean bore diameter
d_1	–	Nominal diameter at the theoretical large end of a tapered bore	–
$t_{\Delta d1mp}$	ⓁⓅ ⓈⓉ Ⓢ ⓐ Ⓢ Ⓢ	Deviation of a mid-range size (out of two-point sizes) of bore diameter at the theoretical large end of a tapered bore from its nominal size	–
D	–	Nominal outside diameter	Nominal outside diameter
$t_{\Delta Ds}$	ⓁⓅ	Deviation of a two-point size of outside diameter from its nominal size	Deviation of a single outside diameter
t_{VDsp}	ⓁⓅ Ⓢ Ⓡ Ⓜ ⓐ ⓐ Ⓢ	Range of two-point sizes of outside diameter in any cross-section	Variation of outside diameter in a single plane
$t_{\Delta Dmp}$	ⓁⓅ ⓈⓉ Ⓜ ⓐ ⓐ Ⓢ	Deviation of a mid-range size (out of two-point sizes) of outside diameter in any cross-section from its nominal size $Dmp = (D \text{ max} + D \text{ min})/2$ $\Delta Dmp = Dmp - D$	Deviation of mean outside diameter in a single plane
t_{VDmp}	ⓁⓅ ⓈⓉ Ⓜ ⓐ ⓐ Ⓢ Ⓢ Ⓡ	Range of mid-range sizes (out of two-point sizes) of outside diameter obtained from any cross-section $VDmp = Dmp \text{ max} - Dmp \text{ min}$	Variation of mean outside diameter
D₁	–	Nominal outside diameter of outer ring flange	–
$t_{\Delta D1s}$	ⓁⓅ	Deviation of a two-point size of outside diameter of outer ring flange from its nominal size	–









continued ▲▼

1) Symbols for the nominal dimension are printed in bold; they indicate size dimensions and spacings.

2) Symbols in accordance with ISO 15241 (exception: font).

6

Symbols for nominal dimensions, characteristics and specification modifiers for radial rolling bearings in accordance with ISO 492:2014

Symbol for nominal dimension¹⁾²⁾		GPS symbol and specification modifier	Description for radial bearings	Old term
Tolerance symbol for characteristic²⁾		Symbols in accordance with ISO 1101 and ISO 14405-1	In accordance with ISO 492:2014 (based on ISO 1101, ISO 5459 and ISO 14405-1)	In accordance with ISO 1132-1:2000
Running accuracy				
t_{Kea}	 ³⁾		Circular radial run-out of outer ring outside surface of assembled bearing with respect to datum, i.e. axis, established from the inner ring bore surface	Radial run-out of outer ring of assembled bearing
t_{Kia}	 ³⁾		Circular radial run-out of inner ring bore surface of assembled bearing with respect to datum, i.e. axis, established from the outer ring outside surface	Radial run-out of inner ring of assembled bearing
t_{Sd}	 ³⁾		Circular axial run-out of inner ring face with respect to datum, i.e. axis, established from the inner ring bore surface	Perpendicularity of inner ring face with respect to the bore
t_{SD}			Perpendicularity of outer ring outside surface axis with respect to datum established from the outer ring face	Perpendicularity of outer ring outside surface with respect to the face
t_{SD1}			Perpendicularity of outer ring outside surface axis with respect to datum established from the outer ring flange back face	Perpendicularity of outer ring outside surface with respect to the flange back face
t_{Sea}	 ³⁾		Circular axial run-out of outer ring face of assembled bearing with respect to datum, i.e. axis, established from the inner ring bore surface	Axial run-out of outer ring of assembled bearing
t_{Sea1}	 ³⁾		Circular axial run-out of outer ring flange back face of assembled bearing with respect to datum, i.e. axis, established from the inner ring bore surface	Axial run-out of outer ring flange back face of assembled bearing
t_{Sia}	 ³⁾		Circular axial run-out of inner ring face of assembled bearing with respect to datum, i.e. axis, established from the outer ring outside surface	Axial run-out of inner ring of assembled bearing
Tapered bore				
SL	–		Taper slope: Taper slope is the difference between nominal diameters at the theoretical large end and small end of a tapered bore $SL = d_1 - d$ $SL = \text{spacing}$	–
$t_{\Delta SL}$	–		Deviation of taper slope of a tapered inner ring bore from its nominal size (description based on DIN EN ISO 1119) $\Delta SL = \Delta d1mp - \Delta dmp$	–
α	–		Frustum angle of tapered inner ring bore	–

continued 

¹⁾ Symbols for the nominal dimension are printed in bold; they indicate size dimensions and spacings.
²⁾ Symbols in accordance with ISO 15241 (exception: font).
³⁾ Specification modifiers for the direction of action of the mass, as well as fixed and movable parts necessary in accordance with ISO/TS 17863.

6

Symbols for nominal dimensions, characteristics and specification modifiers for radial rolling bearings in accordance with ISO 492:2014

Symbol for nominal dimension¹⁾²⁾ Tolerance symbol for characteristic ³⁾	GPS symbol and specification modifier	Description for radial bearings	Old term
	Symbols in accordance with ISO 1101 and ISO 14405-1	In accordance with ISO 492:2014 (based on ISO 1101, ISO 5459 and ISO 14405-1)	In accordance with ISO 1132-1:2000
Width of assembled bearing			
T	–	Nominal assembled bearing width	Nominal bearing width
$t_{\Delta T_s}$	$\textcircled{\text{GN}}^3)$	Deviation of minimum circumscribed size of assembled bearing width from its nominal size	Deviation of the actual bearing width
T₁	–	Nominal effective width of inner subunit assembled with a master outer ring	Nominal effective width of inner subunit
$t_{\Delta T_{1s}}$	$\textcircled{\text{GN}}^3)$	Deviation of minimum circumscribed size of effective width (inner subunit assembled with a master outer ring) from its nominal size	Deviation of the actual effective width of inner subunit
T₂	–	Nominal effective width of outer ring assembled with a master inner subunit	Nominal effective width of outer ring
$t_{\Delta T_{2s}}$	$\textcircled{\text{GN}}^3)$	Deviation of minimum circumscribed size of effective width (outer ring assembled with a master inner subunit) from its nominal size	Deviation of the actual effective width of outer ring
T_F	–	Nominal assembled flanged bearing width	–
$t_{\Delta T_{Fs}}$	$\textcircled{\text{GN}}^3)$	Deviation of minimum circumscribed size of assembled flange bearing width from its nominal size	–
T_{F2}	–	Nominal effective width of flanged outer ring assembled with a master inner subunit	–
$t_{\Delta T_{F2s}}$	$\textcircled{\text{GN}}^3)$	Deviation of minimum circumscribed size of effective width (flanged outer ring assembled with a master inner subunit) from its nominal size	–

continued ▲

1) Symbols for the nominal dimension are printed in bold; they indicate size dimensions and spacings.

2) Symbols in accordance with ISO 15241 (exception: font).

3) Specification modifiers for the direction of action of the mass, as well as fixed and movable parts necessary in accordance with ISO/TS 17863.



7
 Symbols for nominal dimensions,
 characteristics and
 specification modifiers
 for axial rolling bearings
 in accordance with ISO 199:2014

Symbol for nominal dimension ¹⁾²⁾ Tolerance symbol for characteristic ²⁾		GPS symbol and specification modifier	Description for axial bearings	Old term
		Symbols in accordance with ISO 1101 and ISO 14405-1	In accordance with ISO 199:2014 (based on ISO 1101, ISO 5459 and ISO 14405-1)	In accordance with ISO 1132-1:2000
Diameter				
d	–		Nominal bore diameter of shaft washer, single-direction bearing	Nominal bore diameter of shaft washer
$t_{\Delta dmp}$	(LP) (SD) ACS		Deviation of a mid-range size (out of two-point sizes) of shaft washer bore diameter in any cross-section from its nominal size $dmp = (d_{max} + d_{min})/2$ $\Delta dmp = dmp - d$	Deviation of mean bore diameter in a single plane
t_{Vdsp}	(LP) (SR) ACS		Range of two-point sizes of shaft washer bore diameter in any cross-section $Vdsp = d_{s\ max} - d_{s\ min}$	Variation of bore diameter in a single plane
d₂	–		Nominal bore diameter of central shaft washer, double-direction bearing	–
$t_{\Delta d2mp}$	(LP) (SD) ACS		Deviation of a mid-range size (out of two-point sizes) of central shaft washer bore diameter in any cross-section from its nominal size $d2mp = (d2_{max} + d2_{min})/2$	–
t_{Vd2sp}	(LP) (SR) ACS		Range of two-point sizes of central shaft washer bore diameter in any cross-section	Variation of bore diameter in a single plane
D	–		Nominal outside diameter of housing washer	Nominal outside diameter of bore (housing washer)
$t_{\Delta Dmp}$	(LP) (SD) ACS		Deviation of a mid-range size (out of two-point sizes) of housing washer outside diameter in any cross-section from its nominal size $Dmp = (D_{max} + D_{min})/2$ $\Delta Dmp = Dmp - D$	Deviation of mean outside diameter in a single plane
t_{VDsp}	(LP) (SR) ACS		Range of two-point sizes of housing washer outside diameter in any cross-section $VDsp = D_{s\ max} - D_{s\ min}$	Variation of outside diameter in a single plane
continued ▼				

¹⁾ Symbols for the nominal dimension are printed in bold; they indicate size dimensions and spacings.
²⁾ Symbols in accordance with ISO 1101 and ISO 14405-1.



7

Symbols for nominal dimensions, characteristics and specification modifiers for axial rolling bearings in accordance with ISO 199:2014

Symbol for nominal dimension¹⁾²⁾ Tolerance symbol for characteristic ²⁾	GPS symbol and specification modifier	Description for axial bearings	Old term
	Symbols in accordance with ISO 1101 and ISO 14405-1	In accordance with ISO 199:2014 (based on ISO 1101, ISO 5459 and ISO 14405-1)	In accordance with ISO 1132-1: 2000
Height			
T	–	Nominal assembled bearing height, single-direction bearing	Nominal bearing height
$t_{\Delta Ts}$	$\textcircled{\text{GN}}$ ³⁾	Deviation of minimum circumscribed size of assembled bearing height from its nominal size, single-direction bearing	Deviation of the actual bearing height
T₁	–	Nominal assembled bearing height, double-direction bearing	–
$t_{\Delta T1s}$	$\textcircled{\text{GN}}$ ³⁾	Deviation of minimum circumscribed size of assembled bearing height from its nominal size, double-direction bearing	–
t_{Se} ⁴⁾	$\textcircled{\text{LP}} \textcircled{\text{SR}}$	Axial cylindrical roller bearings Range of two-point sizes of thickness between housing washer raceway and the back face	Variation in thickness between housing washer raceway and back face
	$\textcircled{\text{LS}} \textcircled{\text{SN}} \text{ALS} \textcircled{\text{SR}} \triangleleft \text{=} \square$	Axial ball bearings Range of minimum spherical sizes between the raceway and the opposite back face of the housing washer, obtained from any longitudinal section which includes the housing washer outside surface axis	
t_{Si} ⁴⁾	$\textcircled{\text{LP}} \textcircled{\text{SR}}$	Axial cylindrical roller bearings Range of two-point sizes of thickness between shaft washer raceway and the back face	Variation in thickness between shaft washer raceway and back face
	$\textcircled{\text{LS}} \textcircled{\text{SN}} \text{ALS} \textcircled{\text{SR}} \triangleleft \text{=} \square$	Axial ball bearings Range of minimum spherical sizes between the raceway and the opposite back face of the shaft washer, obtained from any longitudinal section which includes the shaft washer bore axis	
			continued ▲

1) Symbols for the nominal dimension are printed in bold; they indicate size dimensions and spacings.
 2) Symbols in accordance with ISO 1101 and ISO 14405-1.
 3) Specification modifiers for the direction of action of the mass in accordance with ISO/TS 17863.
 4) Valid only for axial ball bearings and axial cylindrical roller bearings with a 90° contact angle.

Radial bearings, excluding tapered roller bearings

8
 Tolerance class Normal,
 inner ring

Tolerance symbols in accordance
 with ISO 492 ▶ 115 | 6

U = upper limit deviation
 L = lower limit deviation

Nominal bore diameter d		Bore deviation $t_{\Delta dmp}$		Variation				Radial runout t_{kia}
mm		μm		t_{Vdsp} μm max.			t_{Vdmp}	μm
				Diameter series			μm	μm
over	incl.	U	L	9	0, 1	2, 3, 4	max.	max.
-	2,5	0	-8	10	8	6	6	10
2,5	10	0	-8	10	8	6	6	10
10	18	0	-8	10	8	6	6	10
18	30	0	-10	13	10	8	8	13
30	50	0	-12	15	12	9	9	15
50	80	0	-15	19	19	11	11	20
80	120	0	-20	25	25	15	15	25
120	180	0	-25	31	31	19	19	30
180	250	0	-30	38	38	23	23	40
250	315	0	-35	44	44	26	26	50
315	400	0	-40	50	50	30	30	60
400	500	0	-45	56	56	34	34	65
500	630	0	-50	63	63	38	38	70
630	800	0	-75	-	-	-	-	80
800	1 000	0	-100	-	-	-	-	90
1 000	1 250	0	-125	-	-	-	-	100
1 250	1 600	0	-160	-	-	-	-	120
1 600	2 000	0	-200	-	-	-	-	140

9
 Tolerance class Normal,
 inner ring width tolerances

Tolerance symbols in accordance
 with ISO 492 ▶ 115 | 6

U = upper limit deviation
 L = lower limit deviation

Nominal bore diameter d		Deviation of inner ring width $t_{\Delta Bs}$			Variation of inner ring width t_{VBS}
mm		μm			μm
		All	Normal	Modified ¹⁾	max.
over	incl.	U	L	L	
-	2,5	0	-40	-	12
2,5	10	0	-120	-250	15
10	18	0	-120	-250	20
18	30	0	-120	-250	20
30	50	0	-120	-250	20
50	80	0	-150	-380	25
80	120	0	-200	-380	25
120	180	0	-250	-500	30
180	250	0	-300	-500	30
250	315	0	-350	-500	35
315	400	0	-400	-630	40
400	500	0	-450	-	50
500	630	0	-500	-	60
630	800	0	-750	-	70
800	1 000	0	-1 000	-	80
1 000	1 250	0	-1 250	-	100
1 250	1 600	0	-1 600	-	120
1 600	2 000	0	-2 000	-	140

¹⁾ Only for bearings manufactured specifically for use as matched pairs, with the exception of deep groove ball bearings.



10

Tolerance class Normal, outer ring¹⁾

Tolerance symbols in accordance with ISO 492 ▶ 115 | 6

U = upper limit deviation

L = lower limit deviation

Nominal size of outside diameter		Deviation of outside diameter		Variation					Radial runout
D		$t_{\Delta Dmp}$		t_{VDsp}				$t_{VDmp}^{2)}$	t_{Kea}
				μm max.					
mm		μm		Open bearings			Bearings with sealing shields or sealing washers	μm	μm
over	incl.	U	L	Diameter series				max.	max.
				9	0, 1	2, 3, 4			
-	6	0	-8	10	8	6	10	6	15
6	18	0	-8	10	8	6	10	6	15
18	30	0	-9	12	9	7	12	7	15
30	50	0	-11	14	11	8	16	8	20
50	80	0	-13	16	13	10	20	10	25
80	120	0	-15	19	19	11	26	11	35
120	150	0	-18	23	23	14	30	14	40
150	180	0	-25	31	31	19	38	19	45
180	250	0	-30	38	38	23	-	23	50
250	315	0	-35	44	44	26	-	26	60
315	400	0	-40	50	50	30	-	30	70
400	500	0	-45	56	56	34	-	34	80
500	630	0	-50	63	63	38	-	38	100
630	800	0	-75	94	94	55	-	55	120
800	1 000	0	-100	125	125	75	-	75	140
1 000	1 250	0	-125	-	-	-	-	-	160
1 250	1 600	0	-160	-	-	-	-	-	190
1 600	2 000	0	-200	-	-	-	-	-	220
2 000	2 500	0	-250	-	-	-	-	-	250

1) $t_{\Delta Cs}$, $t_{\Delta C1s}$, t_{VCs} and t_{VC1s} are identical to $t_{\Delta Bs}$ and t_{VBs} for the inner ring of the corresponding bearing ▶ 122 | 9

2) Applies before assembly of the bearing and after removal of internal and/or external snap rings.

Radial bearings, excluding tapered roller bearings

11
 Tolerance class 6,
 inner ring

Tolerance symbols in accordance
 with ISO 492 ▶ 115 | 6

U = upper limit deviation
 L = lower limit deviation

Nominal bore diameter d		Bore deviation $t_{\Delta dmp}$		Variation				Radial runout t_{kia}
mm		μm		t_{Vdsp} μm max.			t_{Vdmp}	μm
over	incl.	U	L	Diameter series			μm	μm
				9	0, 1	2, 3, 4	max.	max.
-	2,5	0	-7	9	7	5	5	5
2,5	10	0	-7	9	7	5	5	6
10	18	0	-7	9	7	5	5	7
18	30	0	-8	10	8	6	6	8
30	50	0	-10	13	10	8	8	10
50	80	0	-12	15	15	9	9	10
80	120	0	-15	19	19	11	11	13
120	180	0	-18	23	23	14	14	18
180	250	0	-22	28	28	17	17	20
250	315	0	-25	31	31	19	19	25
315	400	0	-30	38	38	23	23	30
400	500	0	-35	44	44	26	26	35
500	630	0	-40	50	50	30	30	40

12
 Tolerance class 6,
 inner ring width tolerances

Tolerance symbols in accordance
 with ISO 492 ▶ 115 | 6

U = upper limit deviation
 L = lower limit deviation

Nominal bore diameter d		Deviation of inner ring width $t_{\Delta Bs}$ μm			Variation of inner ring width t_{VBS}
mm		All	Normal	Modified ¹⁾	μm
over	incl.	U	L	L	max.
-	2,5	0	-40	-	12
2,5	10	0	-120	-250	15
10	18	0	-120	-250	20
18	30	0	-120	-250	20
30	50	0	-120	-250	20
50	80	0	-150	-380	25
80	120	0	-200	-380	25
120	180	0	-250	-550	30
180	250	0	-300	-500	30
250	315	0	-350	-500	35
315	400	0	-400	-630	40
400	500	0	-450	-	45
500	630	0	-500	-	50

¹⁾ Only for bearings manufactured specifically for use as matched pairs, with the exception of deep groove ball bearings.



13
Tolerance class 6,
outer ring¹⁾

Tolerance symbols in accordance
with ISO 492 ▶ 115 | 6

U = upper limit deviation

L = lower limit deviation

Nominal size of outside diameter		Deviation of outside diameter		Variation					Radial runout	
				t_{VDsp} μm max.				$t_{VDmp}^{2)}$	t_{Kea}	
mm		μm		Open bearings		Bearings with sealing shields or sealing washers		μm	μm	
over	incl.	U	L	Diameter series				max.	max.	
				9	0, 1	2, 3, 4				
-	6	0	-7	9	7	5	9	5	8	
6	18	0	-7	9	7	5	9	5	8	
18	30	0	-8	10	8	6	10	6	9	
30	50	0	-9	11	9	7	13	7	10	
50	80	0	-11	14	11	8	16	8	13	
80	120	0	-13	16	16	10	20	10	18	
120	150	0	-15	19	19	11	25	11	20	
150	180	0	-18	23	23	14	30	14	23	
180	250	0	-20	25	25	15	-	15	25	
250	315	0	-25	31	31	19	-	19	30	
315	400	0	-28	35	35	21	-	21	35	
400	500	0	-33	41	41	25	-	25	40	
500	630	0	-38	48	48	29	-	29	50	
630	800	0	-45	56	56	34	-	34	60	
800	1 000	0	-60	75	75	45	-	45	75	

¹⁾ $t_{\Delta Cs}$, $t_{\Delta C1s}$, t_{VCs} and t_{VC1s} are
identical to $t_{\Delta Bs}$ and t_{VBs} for the
inner ring of the corresponding
bearing ▶ 124 | 12

²⁾ Applies before assembly of
the bearing and after removal
of internal and/or external
snap rings.

Radial bearings, excluding tapered roller bearings

14
 Tolerance class 5,
 inner ring

Tolerance symbols in accordance
 with ISO 492 ▶ 115 | 6

U = upper limit deviation
 L = lower limit deviation

Nominal bore diameter		Bore deviation		Variation			Radial runout	Axial runout
d		$t_{\Delta dmp}$		t_{Vdsp}		t_{Vdmp}	t_{Kia}	t_{Sd}
mm		μm		Diameter series		μm	μm	μm
over	incl.	U	L	9	0, 1, 2, 3, 4	max.	max.	max.
-	2,5	0	-5	5	4	3	4	7
2,5	10	0	-5	5	4	3	4	7
10	18	0	-5	5	4	3	4	7
18	30	0	-6	6	5	3	4	8
30	50	0	-8	8	6	4	5	8
50	80	0	-9	9	7	5	5	8
80	120	0	-10	10	8	5	6	9
120	180	0	-13	13	10	7	8	10
180	250	0	-15	15	12	8	10	11
250	315	0	-18	18	14	9	13	13
315	400	0	-23	23	18	12	15	15

15
 Tolerance class 5,
 width tolerances, inner ring

Tolerance symbols in accordance
 with ISO 492 ▶ 115 | 6

U = upper limit deviation
 L = lower limit deviation

Nominal bore diameter		Deviation of inner ring width			Variation of inner ring width	Axial runout of lateral inner ring face
d		$t_{\Delta Bs}$			t_{VBs}	$t_{Sia}^{1)}$
mm		All	Normal	Modified ²⁾	μm	μm
over	incl.	U	L	L	max.	max.
-	2,5	0	-40	-250	5	7
2,5	10	0	-40	-250	5	7
10	18	0	-80	-250	5	7
18	30	0	-120	-250	5	8
30	50	0	-120	-250	5	8
50	80	0	-150	-250	6	8
80	120	0	-200	-380	7	9
120	180	0	-250	-380	8	10
180	250	0	-300	-500	10	13
250	315	0	-350	-500	13	15
315	400	0	-400	-630	15	20

¹⁾ Only for deep groove and angular contact ball bearings.

²⁾ Only for bearings manufactured specifically for use as matched pairs, with the exception of deep groove ball bearings.



16
Tolerance class 5,
outer ring¹⁾

Tolerance symbols in accordance
with ISO 492 ▶ 115 | 6

U = upper limit deviation

L = lower limit deviation

Nominal size of outside diameter		Deviation of outside diameter		Variation			Radial runout	Perpen- dicular- ity	Axial runout	
				$t_{VDsp}^{2)}$ μm max.	$t_{VDmp}^{3)}$	t_{VCs}				t_{Kea}
mm		μm		Diameter series		μm	μm	μm	μm	μm
over	incl.	U	L	9	0, 1, 2, 3, 4	max.	max.	max.	max.	max.
–	6	0	–5	5	4	3	5	5	4	8
6	18	0	–5	5	4	3	5	5	4	8
18	30	0	–6	6	5	3	5	6	4	8
30	50	0	–7	7	5	4	5	7	4	8
50	80	0	–9	9	7	5	6	8	4	10
80	120	0	–10	10	8	5	8	10	4,5	11
120	150	0	–11	11	8	6	8	11	5	13
150	180	0	–13	13	10	7	8	13	5	14
180	250	0	–15	15	11	8	10	15	5,5	15
250	315	0	–18	18	14	9	11	18	6,5	18
315	400	0	–20	20	15	10	13	20	6,5	20
400	500	0	–23	23	17	12	15	23	7,5	23
500	630	0	–28	28	21	14	18	25	9	25
630	800	0	–35	35	26	18	20	30	10	30

¹⁾ $t_{\Delta Cs}$ is identical to $t_{\Delta Bs}$ for the
inner ring of the corresponding
bearing ▶ 126 | 15

²⁾ No values are given for radial
ball bearings with sealing
shields or sealing washers.

³⁾ Applies before assembly
of the bearing and after
removal of internal and/or
external snap rings.

⁴⁾ Only for deep groove and
angular contact ball bearings.

Radial bearings, excluding tapered roller bearings

17
 Tolerance class 4,
 inner ring

Tolerance symbols in accordance
 with ISO 492 ▶ 115 | 6

U = upper limit deviation
 L = lower limit deviation

Nominal bore diameter		Bore deviation		Deviation of a single bore diameter		Variation			Radial runout
d		$t_{\Delta dmp}$ μm		$t_{\Delta ds}$ μm		t_{Vdsp} μm		t_{Vdmp}	t_{Kia}
mm		Diameter series				9	0, 1, 2, 3, 4	μm	μm
over	incl.	U	L	U	L	max.	max.	max.	max.
-	2,5	0	-4	0	-4	4	3	2	2,5
2,5	10	0	-4	0	-4	4	3	2	2,5
10	18	0	-4	0	-4	4	3	2	2,5
18	30	0	-5	0	-5	5	4	2,5	3
30	50	0	-6	0	-6	6	5	3	4
50	80	0	-7	0	-7	7	5	3,5	4
80	120	0	-8	0	-8	8	6	4	5
120	180	0	-10	0	-10	10	8	5	6
180	250	0	-12	0	-12	12	9	6	8

18
 Tolerance class 4,
 width tolerances, inner ring

Tolerance symbols in accordance
 with ISO 492 ▶ 115 | 6

U = upper limit deviation
 L = lower limit deviation

Nominal bore diameter		Deviation of inner ring width			Variation of inner ring width		Axial runout	
d		$t_{\Delta Bs}$ μm			t_{VBS}		$t_{Sia}^{1)}$	t_{Sd}
mm		All	Normal	Modified ²⁾	μm		μm	μm
over	incl.	U	L	L	max.		max.	max.
-	2,5	0	-40	-250	2,5		3	3
2,5	10	0	-40	-250	2,5		3	3
10	18	0	-80	-250	2,5		3	3
18	30	0	-120	-250	2,5		4	4
30	50	0	-120	-250	3		4	4
50	80	0	-150	-250	4		5	5
80	120	0	-200	-380	4		5	5
120	180	0	-250	-380	5		7	6
180	250	0	-300	-500	6		8	7

¹⁾ Only for deep groove and angular contact ball bearings.

²⁾ Only for bearings manufactured specifically for use as matched pairs, with the exception of deep groove ball bearings.



19

Tolerance class 4, outer ring

Tolerance symbols in accordance with ISO 492 ▶ 115 | 6

U = upper limit deviation

L = lower limit deviation

Nominal size of outside diameter		Deviation of outside diameter		Deviation of a single outside diameter		Variation			Radial runout
D		$t_{\Delta Dmp}$ μm		$t_{\Delta Ds}$ μm		$t_{VDsp}^{1)}$ μm max.		t_{VDmp}	t_{Kea}
mm		Diameter series						μm	μm
over	incl.	U	L	U	L	9	0, 1, 2, 3, 4	max.	max.
-	6	0	-4	0	-4	4	3	2	3
6	18	0	-4	0	-4	4	3	2	3
18	30	0	-5	0	-5	5	4	2,5	4
30	50	0	-6	0	-6	6	5	3	5
50	80	0	-7	0	-7	7	5	3,5	5
80	120	0	-8	0	-8	8	6	4	6
120	150	0	-9	0	-9	9	7	5	7
150	180	0	-10	0	-10	10	8	5	8
180	250	0	-11	0	-11	11	8	6	10
250	315	0	-13	0	-13	13	10	7	11
315	400	0	-15	0	-15	15	11	8	13

continued ▼

¹⁾ No values are given for bearings with sealing shields or sealing washers.

19

Tolerance class 4, outer ring

Nominal size of outside diameter		Perpendicularity	Axial runout	Deviation of a single outer ring width	Variation of outer ring width
D		t_{SD} t_{SD1} μm	$t_{Sea}^{1)}$ μm	$t_{\Delta Cs}$ μm	t_{VCs} μm
over	incl.	max.	max.		max.
-	6	2	5	$t_{\Delta Cs}$ is identical to $t_{\Delta Bs}$ for the inner ring of the corresponding bearing ▶ 128 18	2,5
6	18	2	5		2,5
18	30	2	5		2,5
30	50	2	5		2,5
50	80	2	5		3
80	120	2,5	6		4
120	150	2,5	7		5
150	180	2,5	8		5
180	250	3,5	10		7
250	315	4	10		7
315	400	5	13	8	

continued ▲

¹⁾ Only for deep groove and angular contact ball bearings.

Radial bearings, excluding tapered roller bearings

20
 Tolerance class 2,
 inner ring

Tolerance symbols in accordance
 with ISO 492 ▶ 115 | 6

U = upper limit deviation
 L = lower limit deviation

Nominal bore diameter d		Bore deviation $t_{\Delta dmp}$ μm		Deviation of a single bore diameter $t_{\Delta ds}$ μm		Variation		Radial runout $t_{\kappa ia}$
mm		Diameter series				t_{Vdsp}	t_{Vdmp}	
over	incl.	U	L	U	L	μm max.	μm max.	μm max.
-	2,5	0	-2,5	0	-2,5	2,5	1,5	1,5
2,5	10	0	-2,5	0	-2,5	2,5	1,5	1,5
10	18	0	-2,5	0	-2,5	2,5	1,5	1,5
18	30	0	-2,5	0	-2,5	2,5	1,5	2,5
30	50	0	-2,5	0	-2,5	2,5	1,5	2,5
50	80	0	-4	0	-4	4	2	2,5
80	120	0	-5	0	-5	5	2,5	2,5
120	150	0	-7	0	-7	7	3,5	2,5
150	180	0	-7	0	-7	7	3,5	5
180	250	0	-8	0	-8	8	4	5

21
 Tolerance class 2,
 width tolerances, inner ring

Tolerance symbols in accordance
 with ISO 492 ▶ 115 | 6

U = upper limit deviation
 L = lower limit deviation

Nominal bore diameter d		Deviation of inner ring width $t_{\Delta Bs}$ μm			Axial runout		Variation of inner ring width t_{VBs}
mm		All	Normal	Modified ²⁾	t_{Sd}	$t_{\zeta ia}^{1)}$	
over	incl.	U	L	L	μm max.	μm max.	μm max.
-	2,5	0	-40	-250	1,5	1,5	1,5
2,5	10	0	-40	-250	1,5	1,5	1,5
10	18	0	-80	-250	1,5	1,5	1,5
18	30	0	-120	-250	1,5	2,5	1,5
30	50	0	-120	-250	1,5	2,5	1,5
50	80	0	-150	-250	1,5	2,5	1,5
80	120	0	-200	-380	2,5	2,5	2,5
120	150	0	-250	-380	2,5	2,5	2,5
150	180	0	-250	-380	4	5	4
180	250	0	-300	-500	5	5	5

¹⁾ Only for deep groove and angular contact ball bearings.

²⁾ Only for bearings manufactured specifically for use as matched pairs, with the exception of deep groove ball bearings.



22
Tolerance class 2,
outer ring

Tolerance symbols in accordance
with ISO 492 ▶ 115 | 6

U = upper limit deviation
L = lower limit deviation

Nominal outside diameter		Deviation of outside diameter				Variation		Radial runout
D		$t_{\Delta Dmp}$ μm		$t_{\Delta Ds}$ μm		$t_{VDsp}^{1)}$	t_{VDmp}	t_{Kea}
mm		Diameter series						
over	incl.	U	L	U	L	μm max.	μm max.	μm max.
–	6	0	–2,5	0	–2,5	2,5	1,5	1,5
6	18	0	–2,5	0	–2,5	2,5	1,5	1,5
18	30	0	–4	0	–4	4	2	2,5
30	50	0	–4	0	–4	4	2	2,5
50	80	0	–4	0	–4	4	2	4
80	120	0	–5	0	–5	5	2,5	5
120	150	0	–5	0	–5	5	2,5	5
150	180	0	–7	0	–7	7	3,5	5
180	250	0	–8	0	–8	8	4	7
250	315	0	–8	0	–8	8	4	7
315	400	0	–10	0	–10	10	5	8

continued ▼

1) No values are given for bearings with sealing shields or sealing washers.

22
Tolerance class 2,
outer ring

Tolerance symbols in accordance
with ISO 492 ▶ 115 | 6

U = upper limit deviation
L = lower limit deviation

Nominal outside diameter		Perpendicularity	Axial runout	Deviation of a single outer ring width	Variation of outer ring width
D		t_{SD} t_{SD1} μm	$t_{Sea}^{1)}$ μm	$t_{\Delta Cs}$ μm	t_{VCs} μm
over	incl.	max.	max.	max.	max.
–	6	0,75	1,5	$t_{\Delta Cs}$ is identical to $t_{\Delta Bs}$ for the inner ring of the corresponding bearing ▶ 130 21	1,5
6	18	0,75	1,5		1,5
18	30	0,75	2,5		1,5
30	50	0,75	2,5		1,5
50	80	0,75	4		1,5
80	120	1,25	5		2,5
120	150	1,25	5		2,5
150	180	1,25	5		2,5
180	250	2	7		4
250	315	2,5	7		5
315	400	3,5	8	7	

continued ▲

1) Only for deep groove and angular contact ball bearings.

Bearings with tapered bore

23

Tolerances for tapered bores
 in accordance with ISO 492,
 taper 1:12,
 tolerance class Normal

Tolerance symbols in accordance
 with ISO 492 ▶ 130 | 21
 U = upper limit deviation
 L = lower limit deviation

Nominal bore diameter d mm		Bore deviation $t_{\Delta dmp}$ μm		Variation $t_{Vdsp}^{1)}$ μm	Deviation of taper slope $t_{\Delta SL}$ μm	
over	incl.	U	L	max.	U	L
18	30	+33	0	13	+21	0
30	50	+39	0	16	+25	0
50	80	+46	0	19	+30	0
80	120	+54	0	22	+35	0
120	180	+63	0	40	+40	0
180	250	+72	0	46	+46	0
250	315	+81	0	52	+52	0
315	400	+89	0	57	+57	0
400	500	+97	0	63	+63	0
500	630	+110	0	70	+70	0
630	800	+125	0	–	+80	0
800	1 000	+140	0	–	+90	0

¹⁾ Valid in any radial cross-section
 of the bore.

24

Tolerances for tapered bores,
 taper 1:30,
 tolerance class Normal

Tolerance symbols in accordance
 with ISO 492 ▶ 130 | 21
 U = upper limit deviation
 L = lower limit deviation

Nominal bore diameter d mm		Bore deviation $t_{\Delta dmp}$ μm		Variation $t_{Vdsp}^{1)}$ μm	Deviation of taper slope $t_{\Delta SL}$ μm	
over	incl.	U	L	max.	U	L
–	80	+15	0	19	+35	0
80	120	+20	0	25	+40	0
120	180	+25	0	31	+50	0
180	250	+30	0	38	+55	0
250	315	+35	0	44	+60	0
315	400	+40	0	50	+65	0
400	500	+45	0	56	+75	0
500	630	+50	0	63	+85	0
630	800	+75	0	–	+100	0
800	1 000	+100	0	–	+100	0

¹⁾ Valid in any radial cross-section
 of the bore.

Taper 1:12

*Taper 1:12
 is standardised*

For rolling bearings with a tapered bore, the standardised taper is 1:12. This corresponds to a half taper angle ($\alpha/2 = 2^\circ 23' 9,4''$); basic taper angle $\alpha = 4^\circ 46' 18,8''$. An exception is spherical roller bearings of the dimension series 40, 41 and 42 (the taper in this case is 1:30).

For the dimensions and tolerances defined in ISO 492:2014 for a tapered bore ▶ 132 | 21.



21

Tolerances for tapered bores

Taper 1:12
 Half of taper angle
 $\alpha/2 = 2^\circ 23' 9,4''$;
 theoretical large end diameter
 $d_1 = d + 1/12 \cdot B$
 $SL = d_1 - d = 2B \cdot \tan(\alpha/2)$
 $\Delta SL = \Delta d_{1mp} - \Delta d_{mp}$

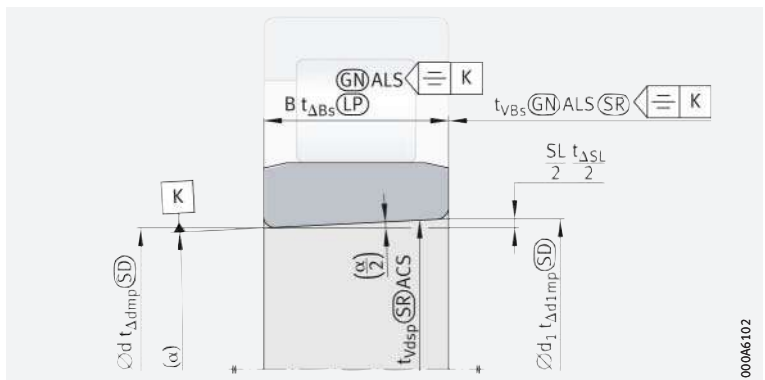

00046102



Axial bearings

25

Bore diameter tolerances
for shaft locating washers
to ISO 199:2014

Tolerance symbols in accordance
with ISO 199 ▶ 120 7

U = upper limit deviation

L = lower limit deviation

Nominal bore diameter		Tolerance class Normal, 6 and 5			Tolerance class 4		
d mm		Bore deviation $t_{\Delta dmp}$ μm		Variation t_{Vdsp} μm	Bore deviation $t_{\Delta dmp}$ μm		Variation t_{Vdsp} μm
over	incl.	U	L	max.	U	L	max.
–	18	0	–8	6	0	–7	5
18	30	0	–10	8	0	–8	6
30	50	0	–12	9	0	–10	8
50	80	0	–15	11	0	–12	9
80	120	0	–20	15	0	–15	11
120	180	0	–25	19	0	–18	14
180	250	0	–30	23	0	–22	17
250	315	0	–35	26	0	–25	19
315	400	0	–40	30	0	–30	23
400	500	0	–45	34	0	–35	26
500	630	0	–50	38	0	–40	30
630	800	0	–75	55	0	–50	40
800	1 000	0	–100	75	0	–	–
1 000	1 250	0	–125	95	0	–	–

26

Outside diameter tolerances
for housing locating washers
to ISO 199:2014

Tolerance symbols in accordance
with ISO 199 ▶ 120 7

U = upper limit deviation

L = lower limit deviation

Nominal outside diameter		Tolerance class Normal, 6 and 5			Tolerance class 4		
D mm		Deviation of outside diameter $t_{\Delta Dmp}$ μm		Variation t_{VDsp} μm	Deviation of outside diameter $t_{\Delta Dmp}$ μm		Variation t_{VDsp} μm
over	incl.	U	L	max.	U	L	max.
10	18	0	–11	8	0	–7	5
18	30	0	–13	10	0	–8	6
30	50	0	–16	12	0	–9	7
50	80	0	–19	14	0	–11	8
80	120	0	–22	17	0	–13	10
120	180	0	–25	19	0	–15	11
180	250	0	–30	23	0	–20	15
250	315	0	–35	26	0	–25	19
315	400	0	–40	30	0	–28	21
400	500	0	–45	34	0	–33	25
500	630	0	–50	38	0	–38	29
630	800	0	–75	55	0	–45	34
800	1 000	0	–100	75	0	–60	45
1 000	1 250	0	–125	95	–	–	–
1 250	1 600	0	–160	120	–	–	–

27
 Variation in washer thickness
 for shaft and housing locating
 washers to ISO 199:2014

Tolerance symbols in accordance
 with ISO 199 ▶ 120 | 7

Nominal bore diameter d		Tolerance class				Tolerance class Normal, 6, 5, 4
		Normal	6	5	4	
mm		Variation in thickness between shaft washer raceway and back face				Variation in thickness between housing washer raceway and back face
over		t_{Si}	t_{Se}	t_{Se}		
incl.		μm	μm	μm		
		max.	max.	max.		
–	18	10	5	3	2	Identical to t_{Si} for the shaft locating washer of the corresponding bearing
18	30	10	5	3	2	
30	50	10	6	3	2	
50	80	10	7	4	3	
80	120	15	8	4	3	
120	180	15	9	5	4	
180	250	20	10	5	4	
250	315	25	13	7	5	
315	400	30	15	7	5	
400	500	30	18	9	6	
500	630	35	21	11	7	
630	800	40	25	13	8	
800	1 000	45	30	15	–	
1 000	1 250	50	35	18	–	

Tolerances for nominal bearing height

Tolerances and symbols for nominal size

The tolerances for nominal height are given in ▶ 135 | 28.
 The corresponding symbols for nominal size are shown in ▶ 134 | 22.

22
 Nominal size symbols
 for nominal bearing height

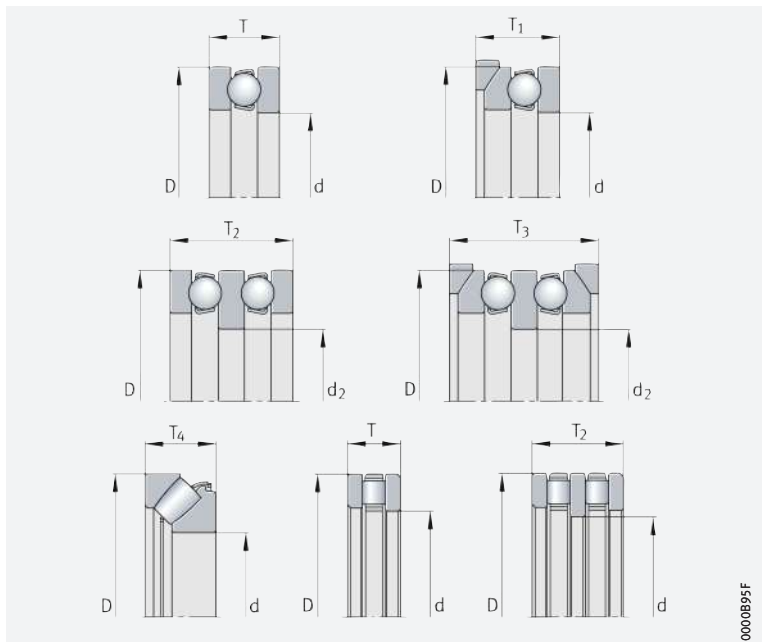



28

Tolerances for nominal bearing height

Tolerance symbols in accordance with ISO 199 ▶ 120 | 7

U = upper limit deviation
L = lower limit deviation

Nominal bore diameter d		t _{Ts}		t _{T1s}		t _{T2s}	
mm		μm		μm		μm	
over	incl.	U	L	U	L	U	L
–	30	20	–250	100	–250	150	–400
30	50	20	–250	100	–250	150	–400
50	80	20	–300	100	–300	150	–500
80	120	25	–300	150	–300	200	–500
120	180	25	–400	150	–400	200	–600
180	250	30	–400	150	–400	250	–600
250	315	40	–400	200	–400	350	–700
315	400	40	–500	200	–500	350	–700
400	500	50	–500	300	–500	400	–900
500	630	60	–600	350	–600	500	–1 100
630	800	70	–750	400	–750	600	–1 300
800	1 000	80	–1 000	450	–1 000	700	–1 500
1 000	1 250	100	–1 400	500	–1 400	900	–1 800

continued ▼

28

Tolerances for nominal bearing height

Tolerance symbols in accordance with ISO 199 ▶ 120 | 7

U = upper limit deviation
L = lower limit deviation

Nominal bore diameter d		t _{T3s}		t _{T4s}	
mm		μm		μm	
over	incl.	U	L	U	L
–	30	300	–400	20	–300
30	50	300	–400	20	–300
50	80	300	–500	20	–400
80	120	400	–500	25	–400
120	180	400	–600	25	–500
180	250	500	–600	30	–500
250	315	600	–700	40	–700
315	400	600	–700	40	–700
400	500	750	–900	50	–900
500	630	900	–1 100	60	–1 200
630	800	1 100	–1 300	70	–1 400
800	1 000	1 300	–1 500	80	–1 800
1 000	1 250	1 600	–1 800	100	–2 400

continued ▲

7.11

Chamfer dimensions

Radial bearings, excluding tapered roller bearings

Minimum and maximum values

The minimum and maximum values for the bearings are given in the table Limit values for chamfer dimensions to DIN 620-6 ▶ 136 | 29, ▶ 136 | 23.



For drawn cup needle roller bearings with open ends HK, drawn cup needle roller bearings with closed end BK and aligning needle roller bearings PNA and RPNA, the chamfer dimensions deviate from DIN 620-6. The lower limit values for r are given in the product tables.

Tapered roller bearings

Chamfer dimensions for tapered roller bearings ▶ 137 | 24 and ▶ 137 | 30, for axial bearings ▶ 138 | 25 and ▶ 138 | 31.

23

Chamfer dimensions for radial bearings (not including tapered roller bearings)

- ① Symmetrical ring cross-section with identical chamfers on both rings
- ② Symmetrical ring cross-section with different chamfers on both rings
- ③ Asymmetrical ring cross-section
- ④ Annular slot on outer ring, bearing with rib washer
- ⑤ L-section ring

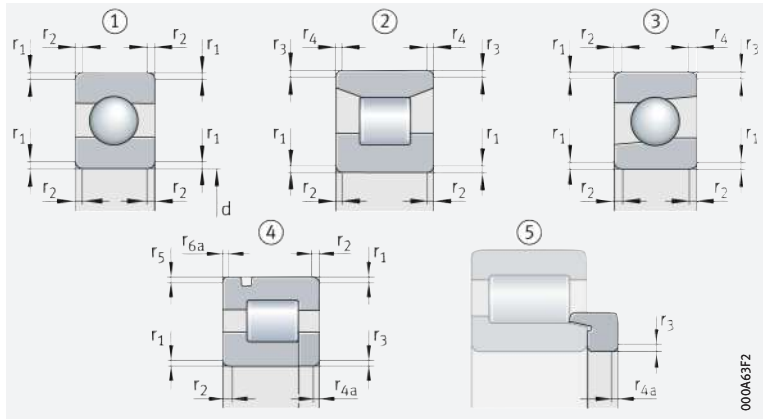

29

Limit values for chamfer dimensions to DIN 620-6

r ¹⁾ mm	d mm		r ₁ to r _{6a} mm	r ₁ , r ₃ , r ₅ mm	r ₂ , r ₄ , r ₆ ²⁾ mm	r _{4a} , r _{6a} mm
	over	incl.	min.	max.	max.	max.
0,05	–	–	0,05	0,1	0,2	0,1
0,08	–	–	0,08	0,16	0,3	0,16
0,1	–	–	0,1	0,2	0,4	0,2
0,15	–	–	0,15	0,3	0,6	0,3
0,2	–	–	0,2	0,5	0,8	0,5
0,3	–	40	0,3	0,6	1	0,8
	40	–	0,3	0,8	1	0,8
0,5	–	40	0,5	1	2	1,5
	40	–	0,5	1,3	2	1,5
0,6	–	40	0,6	1	2	1,5
	40	–	0,6	1,3	2	1,5
1	–	50	1	1,5	3	2,2
	50	–	1	1,9	3	2,2
1,1	–	120	1,1	2	3,5	2,7
	120	–	1,1	2,5	4	2,7
1,5	–	120	1,5	2,3	4	3,5
	120	–	1,5	3	5	3,5
2	–	80	2	3	4,5	4
	80	220	2	3,5	5	4
	220	–	2	3,8	6	4
2,1	–	280	2,1	4	6,5	4,5
	280	–	2,1	4,5	7	4,5
2,5	–	100	2,5	3,8	6	5
	100	280	2,5	4,5	6	5
	280	–	2,5	5	7	5
3	–	280	3	5	8	5,5
	280	–	3	5,5	8	5,5
4	–	–	4	6,5	9	6,5
5	–	–	5	8	10	8
6	–	–	6	10	13	10
7,5	–	–	7,5	12,5	17	12,5
9,5	–	–	9,5	15	19	15
12	–	–	12	18	24	18
15	–	–	15	21	30	21
19	–	–	19	25	38	25

¹⁾ The nominal chamfer dimension r is identical to the smallest permissible chamfer dimension r_{min}.

²⁾ For bearings with a width of 2 mm or less, the values for r₁ apply.



Tapered roller bearings

Minimum and maximum values

Minimum and maximum values for metric tapered roller bearings
 ▶ 137 | 24 and ▶ 137 | 30.

24
 Chamfer dimensions
 for metric tapered roller bearings

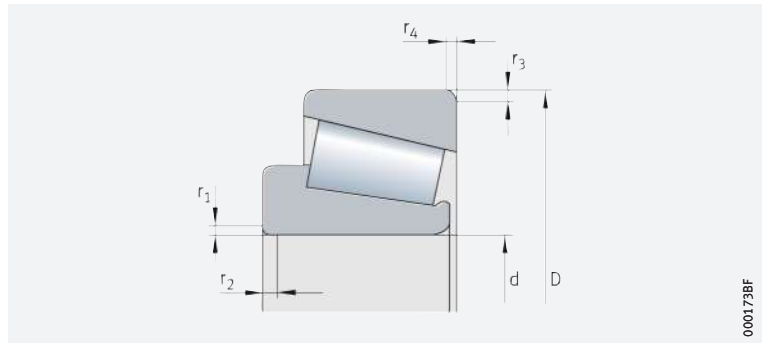

000173BF

30
 Limit values
 for chamfer dimensions

r ¹⁾ mm	d, D mm		r ₁ to r ₄ mm	r ₁ , r ₃ mm	r ₂ , r ₄ mm
	over	incl.	min.	max.	max.
0,3	–	40	0,3	0,7	1,4
	40	–	0,3	0,9	1,6
0,6	–	40	0,6	1,1	1,7
	40	–	0,6	1,3	2
1	–	50	1	1,6	2,5
	50	–	1	1,9	3
1,5	–	120	1,5	2,3	3
	120	250	1,5	2,8	3,5
	250	–	1,5	3,5	4
2	–	120	2	2,8	4
	120	250	2	3,5	4,5
	250	–	2	4	5
2,5	–	120	2,5	3,5	5
	120	250	2,5	4	5,5
	250	–	2,5	4,5	6
3	–	120	3	4	5,5
	120	250	3	4,5	6,5
	250	400	3	5	7
	400	–	3	5,5	7,5
4	–	120	4	5	7
	120	250	4	5,5	7,5
	250	400	4	6	8
	400	–	4	6,5	8,5
5	–	180	5	6,5	8
	180	–	5	7,5	9
6	–	180	6	7,5	10
	180	–	6	9	11

¹⁾ The nominal chamfer dimension r is identical to the smallest permissible chamfer dimension r_{min}.

Axial bearings

Minimum and maximum values

Minimum and maximum values for the bearings ▶ 138 | 25 and ▶ 138 | 31. The values in the table correspond to DIN 620-6. In the case of axial deep groove ball bearings, the tolerances for the chamfer dimensions are identical in both axial and radial directions.

25
 Chamfer dimensions for axial bearings

- ① Single direction axial deep groove ball bearing with flat housing locating washer
- ② Double direction axial deep groove ball bearing with spherical housing locating washers and seating washers
- ③ Single direction axial cylindrical roller bearing
- ④ Single direction axial spherical roller bearing

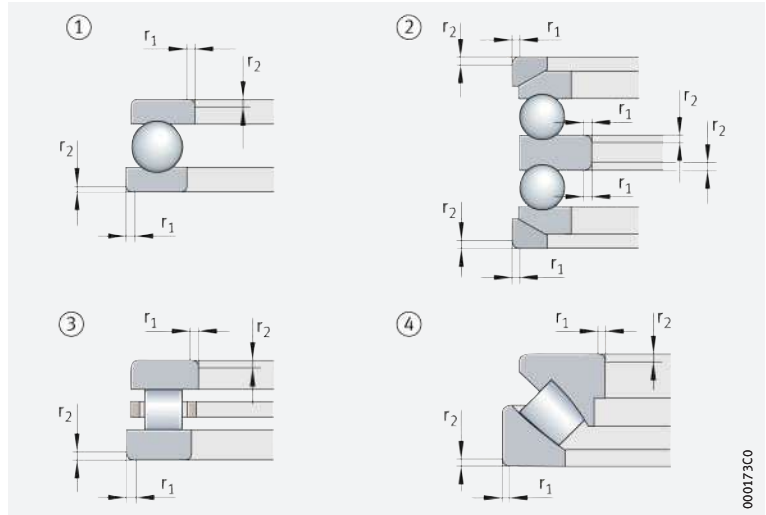

31
 Limit values for chamfer dimensions

r ¹⁾ mm	r ₁ , r ₂	
	mm min.	mm max.
0,05	0,05	0,1
0,08	0,08	0,16
0,1	0,1	0,2
0,15	0,15	0,3
0,2	0,2	0,5
0,3	0,3	0,8
0,6	0,6	1,5
1	1	2,2
1,1	1,1	2,7
1,5	1,5	3,5
2	2	4
2,1	2,1	4,5
3	3	5,5
4	4	6,5
5	5	8
6	6	10
7,5	7,5	12,5
9,5	9,5	15
12	12	18
15	15	21
19	19	25

¹⁾ The nominal chamfer dimension r is identical to the smallest permissible chamfer dimension r_{min}.



8 Design of bearing arrangements

8.1 Arrangement of bearings

☞ *Support of a shaft normally requires two bearings*

The guidance and support of a rotating machine part generally requires at least two bearings arranged at a certain distance from each other (exceptions: four point contact, crossed roller and slewing bearings). Depending on the application, a decision is made between a locating/non-locating bearing arrangement, an adjusted bearing arrangement and a floating bearing arrangement.

☞ *The non-locating bearing compensates for differences in distance*

Locating/non-locating bearing arrangement

On a shaft supported by two radial bearings, the distances between the bearing seats on the shaft and in the housing frequently do not coincide as a result of manufacturing tolerances. The distances may also change as a result of temperature increases during operation. These differences in distance are compensated in the non-locating bearing. Examples of locating/non-locating bearing arrangements ▶ 140 | ☞ 1.

☞ *Suitable non-locating bearings*

Non-locating bearings

Ideal non-locating bearings are cylindrical roller bearings with cage of series N and NU or needle roller bearings. In these bearings, the roller and cage assembly can be displaced on the raceway of the bearing ring without ribs. All other bearing types, for example deep groove ball bearings and spherical roller bearings, can only act as non-locating bearings if one bearing ring has a fit that allows displacement. The bearing ring subjected to point load therefore has a loose fit; this is normally the outer ring.

☞ *Suitable locating bearings*

Locating bearings

The locating bearing guides the shaft in an axial direction and supports external axial forces. In order to prevent axial bracing, shafts with more than two bearings have only one locating bearing. The type of bearing selected as a locating bearing depends on the magnitude of the axial forces and the accuracy with which the shafts must be axially guided.

A double row angular contact ball bearing, for example, will give closer axial guidance than a deep groove ball bearing or a spherical roller bearing. A pair of symmetrically arranged angular contact ball bearings or tapered roller bearings used as locating bearings will also provide extremely close axial guidance.

There are particular advantages in using angular contact ball bearings of the universal design. The bearings can be fitted in pairs in any O or X arrangement without shims. Angular contact ball bearings of the universal design are matched so that, in an X or O arrangement, they have a low axial internal clearance (design UA), zero clearance (UO) or slight preload (UL).

In gearboxes, a four point contact bearing is sometimes fitted directly adjacent to a cylindrical roller bearing to give a locating bearing arrangement. The four point contact bearing, without radial support of the outer ring, can only support axial forces. The radial force is supported by the cylindrical roller bearing.

If a lower axial force is present, a cylindrical roller bearing with cage of series NUP can also be used as a locating bearing.

🔗 *No adjustment or setting work with matched pairs of tapered roller bearings*

Fitting is also made easier when using matched pairs of tapered roller bearings as locating bearings (313...N11CA). They are matched with appropriate axial internal clearance so that no adjustment or setting work is required.

1
 Locating/non-locating bearing arrangements
 ⇔ = non-locating bearing

- ① Locating bearing: deep groove ball bearing
 Non-locating bearing: deep groove ball bearing
- ② Locating bearing: spherical roller bearing
 Non-locating bearing: spherical roller bearing
- ③ Locating bearing: deep groove ball bearing
 Non-locating bearing: cylindrical roller bearing NU
- ④ Locating bearing: spherical roller bearing
 Non-locating bearing: toroidal roller bearing
- ⑤ Locating bearing: double row angular contact ball bearing
 Locating bearing: cylindrical roller bearing NU
- ⑥ Locating bearing: four point contact bearing and cylindrical roller bearing NU (outer ring of four point contact bearing not radially retained)
 Non-locating bearing: cylindrical roller bearing NU
- ⑦ Locating bearing: tapered roller bearing
 Non-locating bearing: cylindrical roller bearing NU
- ⑧ Locating bearing: cylindrical roller bearing NUP
 Non-locating bearing: cylindrical roller bearing NU

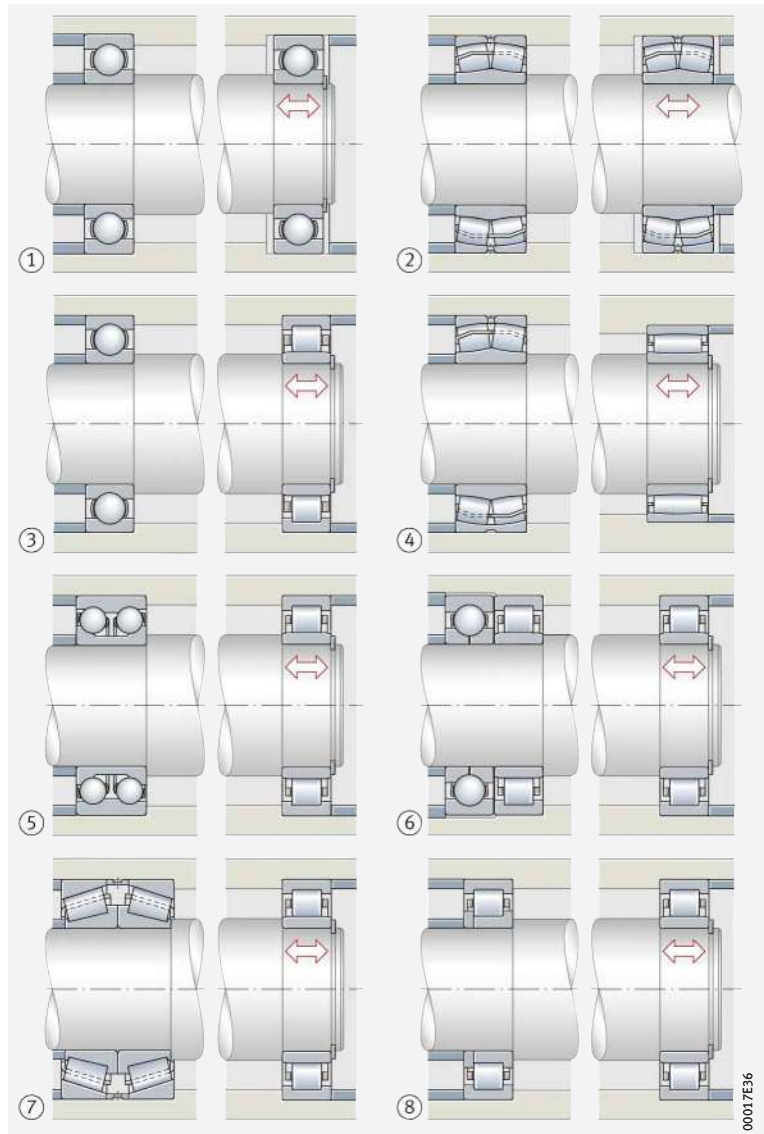

Adjusted bearing arrangement

🔗 *The “adjustment” process*

An adjusted bearing arrangement is generally constructed from two angular contact bearings (angular contact ball bearings, tapered roller bearings) in a mirror image arrangement ▶ 141| 2 and ▶ 141| 3. The inner and outer rings of the bearings are displaced relative to each other until the required clearance or the required preload is achieved. This process is known as “adjustment”.

Angular contact bearings and deep groove ball bearings suitable for adjusted bearing arrangements

🔗 *Angular contact bearings support radial and axial forces*

Angular contact bearings support forces comprising a radial and an axial component. These are thus a combination of a radial and an axial bearing. Depending on the size of the nominal contact angle α , angular contact bearings are classified as radial or axial bearings.



Deep groove ball bearings are also suitable

Deep groove ball bearings can also be used for an adjusted bearing arrangement; these are then angular contact ball bearings with a small nominal contact angle.

Due to the possibility of regulating the clearance, adjusted bearing arrangements are particularly suitable if close guidance is necessary.

O or X arrangement

Two arrangements

In an adjusted bearing arrangement, an O or X arrangement of the bearings is essentially possible.

The contact cone apexes point outwards or inwards

In the O arrangement, the cones and their apexes formed by the contact lines (the contact cone apexes S) point outwards, in the X arrangement, the cones point inwards ▶ 141 | 2.

In angular contact ball bearings and tapered roller bearings, the contact lines of the rolling element forces coincide at the contact cone apexes S ▶ 141 | 2 and ▶ 141 | 3. In adjusted bearing arrangements, the bearing spacing is therefore defined as the spacing of the contact cone apexes.

The support spacing is larger in an O arrangement

The resulting support spacing H is larger in an O arrangement than in an X arrangement. An O arrangement should be used in preference if the component with small bearing spacing must be guided with the smallest possible tilting clearance or tilting forces must be supported.



Adjusted bearing arrangement with angular contact ball bearings

S = contact cone apex
H = support spacing

- ① O arrangement
- ② X arrangement

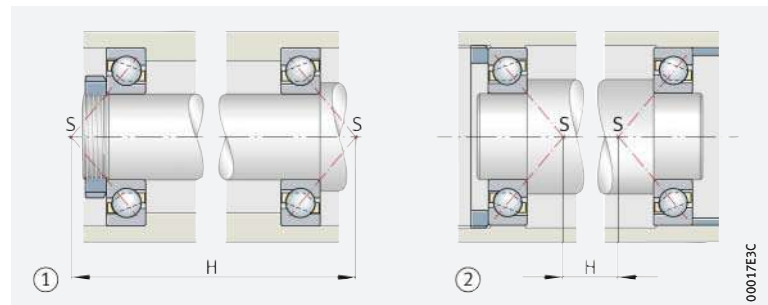

Influence of thermal expansion in O and X arrangements



When deciding between an O and X arrangement, attention must also be paid to the temperature conditions and thermal expansions. This is based on the position of the roller cone apexes R. The roller cone apex R represents the intersection point of the extended, inclined outer ring raceway with the bearing axis ▶ 141 | 3.

X arrangement

If the shaft is warmer than the housing ($T_W > T_G$), the shaft expands more than the housing in an axial and radial direction. As a result, the clearance set in an X arrangement decreases in every case (assuming the following precondition: shaft and housing of same material).



Adjusted bearing arrangement with tapered roller bearings

X arrangement

R = roller cone apex
S = contact cone apex

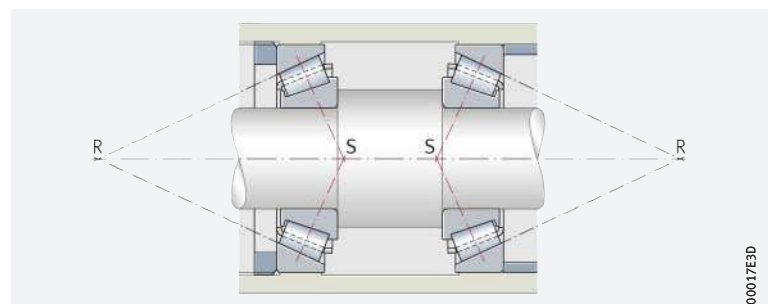

Temperature behaviour and thermal expansion in an O arrangement

The behaviour is different in an O arrangement. A distinction must be drawn between three cases here:

- If the roller cone apices R coincide at a point, the axial and radial thermal expansion cancel each other out and the clearance set is maintained ▶ 142 | 4
- If the roller cones overlap with a small bearing spacing, the radial expansion has a stronger effect than the axial expansion on the bearing clearance ▶ 142 | 5: the axial clearance is reduced. This must be taken into consideration in the adjustment of bearings
- In the third case, the roller cones do not overlap with a large bearing spacing ▶ 142 | 6. The radial expansion then has a weaker effect than the axial expansion on the bearing clearance: the axial clearance is increased.

4
 Adjusted bearings in an O arrangement, the roller cone apices coincide

R = roller cone apex
 S = contact cone apex

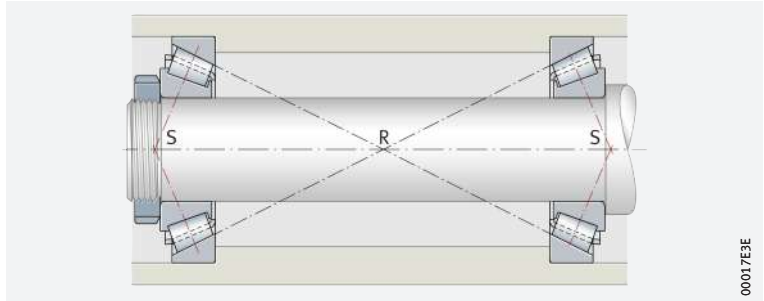

00017E3E

5
 Adjusted bearings in an O arrangement, the roller cone apices overlap

R = roller cone apex
 S = contact cone apex

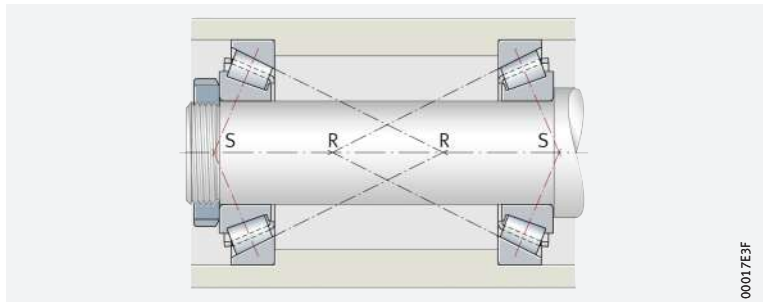

00017E3F

6
 Adjusted bearings in an O arrangement, the roller cone apices do not overlap

R = roller cone apex
 S = contact cone apex

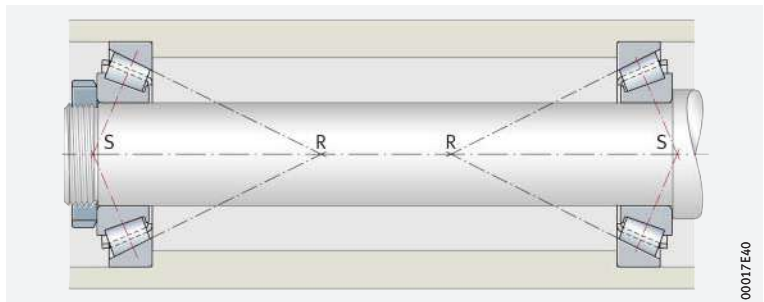

00017E40

Sliding seat in the bearing ring to be adjusted

Sliding seat only permissible on the bearing ring with point load

Whether the inner ring or outer ring is adjusted depends on the degree of accessibility of the adjustment elements, such as nuts and covers. Since the bearing ring to be adjusted must be easily displaced, attention must also be paid in these considerations to the fits of the bearing rings.



A sliding seat should fundamentally only be permitted on the ring that is subject to point load.



Preloading using springs

Elastic adjustment

Adjusted bearing arrangements can also be achieved by preloading using springs ▶143|☐7. This elastic adjustment method compensates for thermal expansion. It can also be used where bearing arrangements are at risk of vibration while stationary.



Bearing arrangement adjusted by means of spring washer

- ① Deep groove ball bearing
- ② Spring washer (spring preload)
- ③ Cover

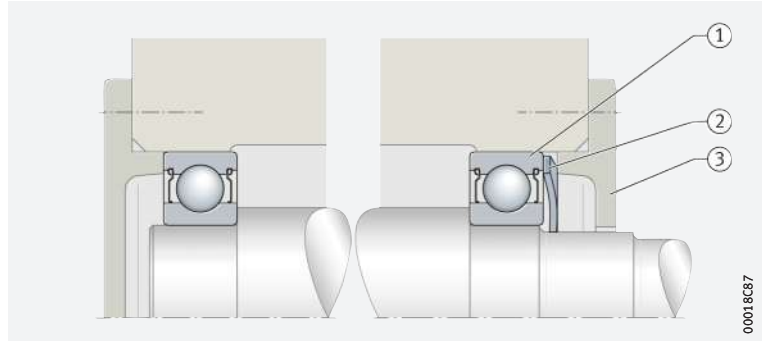

00018C87

Difference from the adjusted bearing arrangement: this does not give close axial guidance

Floating bearing arrangement

The floating bearing arrangement is essentially similar in its arrangement to the adjusted bearing arrangement. While freedom from clearance or even preload is desirable when warm from operation in the latter case, floating bearing arrangements always have an axial clearance s of several tenths of a millimetre depending on the bearing size ▶143|☐8. The value s is defined as a function of the required guidance accuracy such that the bearings are not axially stressed even under unfavourable thermal conditions.

A floating bearing arrangement is suitable for bearings that must not be adjusted

Suitable bearing types

For a floating bearing arrangement, almost all bearing types can be considered that must not be adjusted; examples ▶143|☐8. Floating arrangements are thus possible with, for example, deep groove ball bearings, self-aligning ball bearings and spherical roller bearings; one ring of each of the two bearings (usually the outer ring) then has a sliding seat. In the floating bearing arrangement with cylindrical roller bearings NJ, length compensation is possible within the bearing.



Tapered roller bearings and angular contact ball bearings are not suitable for a floating bearing arrangement, since these bearings must be adjusted in order to run correctly.



Floating bearing arrangements

s = axial displacement distance (axial clearance)

- ① Deep groove ball bearing
- ② Spherical roller bearing
- ③ Cylindrical roller bearing NJ

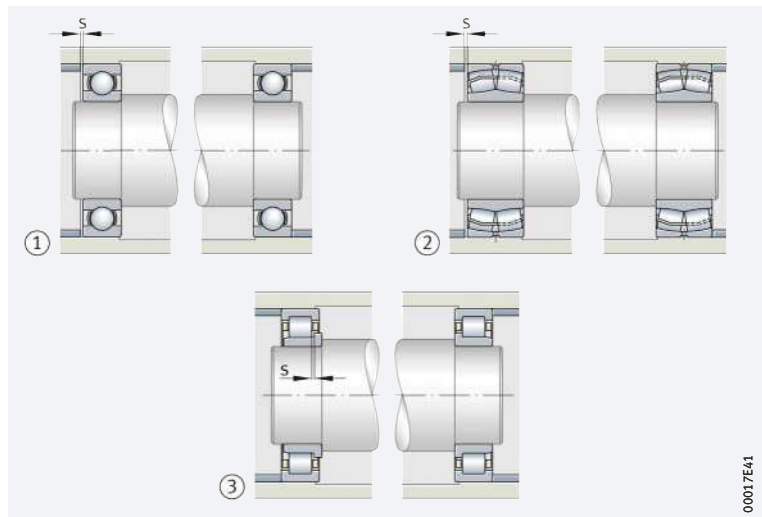

00017E41

8.2 Radial location of bearings

🔗 *Location of the bearing rings in a radial and tangential direction by fit, in an axial direction by form fit*

Rolling bearings must be located on the shaft and in the housing in a radial, axial and tangential direction in accordance with their function. In a radial and tangential direction, this occurs by means of a tight fit. However, this is only possible under certain conditions in an axial direction, therefore rolling bearings are generally axially located by means of form fit.

🔗 *Points to be observed in the selection of fits*

Criteria for selection of fits

The following must be taken into consideration in determining the fit:

- The rolling bearing rings must be well supported over their entire circumference in order to allow full utilisation of the load carrying capacity of the bearing
- The rings must not creep on their mating parts, otherwise the seating surfaces will be damaged
- The non-locating bearing must compensate changes in the length of the shaft and housing and one ring must therefore be axially adjustable
- Mounting and dismounting of the bearings should be possible without a large amount of work.

🔗 *Interference fits*

Interference fits lead to expansion of the inner ring raceway and contraction of the outer ring raceway. The resulting stresses occurring in the rings and the reduction in the radial internal clearance must be taken into consideration in the selection of the fit; see ► 146 and ► 149.

🔗 *Tight fit necessary*

Good support of the bearing rings on their circumference requires rigid seating. The requirement that rings must not creep on their mating parts also requires firm seating. If non-separable bearings must be mounted and dismounted, a tight fit can only be achieved for one bearing ring. In the case of cylindrical roller bearings N, NU and needle roller bearings, both rings can have tight fits, since the length compensation takes place within the bearing and since the rings can be mounted separately. With tight fits and a temperature differential between the inner and outer ring, the radial internal clearance of the bearing is reduced. This must be taken into consideration when selecting the radial internal clearance.

🔗 *Materials other than cast iron or steel*

If materials other than cast iron or steel are used for the adjacent construction, the modulus of elasticity and the differing coefficients of thermal expansion of the materials must also be taken into consideration to achieve rigid seating. For aluminium housings, thin-walled housings and hollow shafts, a closer fit should be selected if necessary in order to achieve the same force locking as with cast iron, steel or solid shafts.

🔗 *Higher loads*

Higher loads, especially shocks, require a fit with larger interference and narrower geometrical tolerances.

Bearing seat for axial bearings



Axial bearings, which support axial loads only, must not be guided radially (with the exception of axial cylindrical roller bearings which have a degree of freedom in the radial direction due to flat raceways). In the case of groove-shaped raceways this is not present and must be achieved by a loose seat for the stationary washer. A rigid seat is normally selected for the rotating washer.

Where axial bearings also support radial forces, such as in axial spherical roller bearings, fits should be selected in the same way as for radial bearings.

🔗 *Contact surfaces of the mating parts*

The contact surfaces of the mating parts must be perpendicular to the axis of rotation (total axial runout tolerance to IT5 or better), in order to ensure uniform load distribution over all the rolling elements.



Conditions of rotation

☞ *Point or circumferential load*

☞ *For point load, a loose fit is also possible*

☞ *For circumferential load, a firm bearing seat is necessary*

The conditions of rotation indicate the motion of one bearing ring with respect to the load direction and are expressed as either circumferential load or point load ▶ 145 | 1.

If the bearing ring is stationary relative to the load direction (point load on the ring), no forces occur that could cause creep of the ring. A tight fit would be desirable here in order to give better support, but a loose fit is also possible since there is no risk that the ring will undergo creep. There is essentially a risk, however, that fretting corrosion will occur.

A bearing ring that rotates relative to the load direction (circumferential load on the ring) will roll on its seat if a loose fit is present and will thus creep in a circumferential direction. If shock type load is present, the ring will slip. In both cases, there is a risk that the seats of the ring and mating part will be damaged by fretting corrosion and wear.



The possible creep or slippage of a bearing ring can only be effectively prevented by a firm bearing seat.

1
Differentiation
between point load and
circumferential load

Condition of rotation	Example	Schematic	Load case	Fit
Rotating inner ring, stationary outer ring	Shaft with weight load		Circumferential load on inner ring and point load on outer ring	Inner ring: tight fit necessary Outer ring: loose fit permissible
Constant load direction				
Stationary inner ring, rotating outer ring	Hub bearing arrangement with significant imbalance			
Load direction rotates with outer ring				
Stationary inner ring, rotating outer ring	Passenger car front wheel track roller (hub bearing arrangement)		Point load on inner ring and circumferential load on outer ring	Inner ring: loose fit permissible Outer ring: tight fit necessary
Constant load direction				
Rotating inner ring, stationary outer ring	Centrifuge, vibrating screen			
Load direction rotates with inner ring				

8.3 Recommended fits

Shaft and housing tolerances

ISO tolerance classes

The tolerances are defined in the form of ISO tolerance classes to ISO 286-1 and ISO 286-2. The designation of the tolerance classes, e.g. “E8”, comprises one or two upper case letters for housings or lower case letters for shafts (= fundamental deviation identifier, which defines the tolerance position relative to the zero line, e.g. “E”) and the grade number of the standard tolerance grade (this defines the tolerance quality, e.g. “8”). A schematic illustration of the most common rolling bearing fits is shown in ▶ 146 | 9.

9
 Shaft and housing fits for rolling bearings

- D = nominal bearing outside diameter
- d = nominal bearing bore diameter
- $t_{\Delta Dmp}$ = deviation of mean bearing outside diameter (in accordance with ISO 492)
- $t_{\Delta dmp}$ = deviation of mean bearing bore diameter (in accordance with ISO 492)

- ① Zero line
- ② Housing
- ③ Shaft
- ④ Clearance fit
- ⑤ Transition fit
- ⑥ Interference fit

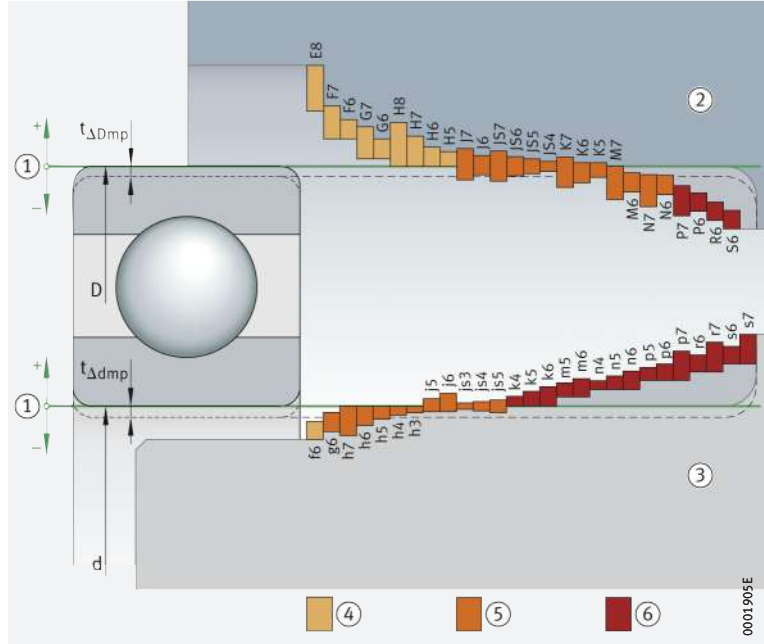

Recommendations for shaft and housing tolerances

The tables ▶ 147 | 2 to ▶ 148 | 5 contain recommendations for the selection of shaft and housing tolerances that are valid for normal mounting and operating conditions. Deviations are possible if particular requirements apply, for example in relation to running accuracy, smooth running or operating temperature. Increased running accuracies thus require closer tolerances such as standard tolerance grade 5 instead of 6. If the inner ring is warmer than the shaft during operation, the seating may loosen to an impermissible extent. A tighter fit must then be selected, for example m6 instead of k6.

Objective: the best overall solution

In some applications, the question of fits can only be resolved by a compromise. The individual requirements must be weighed against each other and those selected that give the best overall solution.



2
Tolerance classes
for cylindrical shaft seats
(radial bearings)

Condition of rotation ¹⁾	Bearing type	Shaft diameter mm		Displacement facility Load	Tolerance class ²⁾ of shaft
		over	incl.		
Point load on inner ring	Ball bearings, roller bearings	All sizes		Inner ring easily displaced	g6 (g5)
				Inner ring not easily displaced, angular contact ball bearings and tapered roller bearings with adjusted inner ring	h6 (j6)
	Needle roller bearings	Non-locating bearing	h6 (g6) ³⁾		
Circumferential load on inner ring or indeterminate load direction	Ball bearings	–	50	Normal loads ⁴⁾	j6 (j5)
			50	100	Low loads ⁵⁾
				Normal and high loads ⁶⁾	k6 (k5)
		100	200	Low loads ⁴⁾	k6 (m6)
				Normal and high loads ⁷⁾	m6 (m5)
		200	–	Low loads	m6 (m5)
	Normal and high loads			n6 (n5)	
	Roller bearings	–	60	Low loads	j6 (j5)
				Normal and high loads	k6 (k5)
		60	200	Low loads	k6 (k5)
				Normal loads	m6 (m5)
				High loads	n6 (n5)
		200	500	Normal loads	m6 (n6)
	High loads, shocks			p6	
	Needle roller bearings	–	50	Low loads	k6
				Normal and high loads	m6
		50	120	Low loads	m6
				Normal and high loads	n6
120		250	Low loads	n6	
			Normal and high loads	p6	
250	400	Low loads	p6		
		Normal and high loads	r6		
400	500	Low loads	r6		
		Normal and high loads	s6		
500	–	Low loads	r6		
		Normal and high loads	s6		

1) Condition of rotation
► 145 | 1.

2) The envelope requirement ©
► 168 | 11 applies.

3) For easy fitting.

4) $C_0/P_0 > 10$.

5) $C_0/P_0 > 12$.

6) $C_0/P_0 < 12$.

7) $C_0/P_0 < 10$.

3
Tolerance classes
for cylindrical shaft seats
(axial bearings)

Load	Bearing type	Shaft diameter mm		Operating conditions	Tolerance class ¹⁾ of shaft
		over	incl.		
Axial load	Axial deep groove ball bearings	All sizes		–	j6
	Axial deep groove ball bearings, double direction			–	k6
	Axial cylindrical roller bearings with shaft locating washer			–	h8
	Axial cylindrical roller and cage assemblies			–	h8
Combined load	Axial spherical roller bearings	All sizes		Point load on shaft locating washer	j6
		–	200	Circumferential load on shaft locating washer	j6 (k6)
		200	–		k6 (m6)

1) The envelope requirement ©
► 168 | 11 applies.

4
Tolerance classes
for bearing seats in housings
(radial bearings)

Condition of rotation ¹⁾	Displacement facility Load	Operating conditions	Tolerance class ²⁾ of bore
Point load on outer ring	Outer ring easily displaced, housing unsplit	The tolerance grade is determined by the running accuracy required	H7 (H6) ³⁾
	Outer ring easily displaced, housing split		H8 (H7)
	Outer ring not easily displaced, housing unsplit	High running accuracy required	H6 (I6)
	Outer ring not easily displaced, angular contact ball bearings and tapered roller bearings with adjusted outer ring, housing split	Normal running accuracy	H7 (I7)
	Outer ring easily displaced	Heat input via shaft	G7 ⁴⁾
Circumferential load on outer ring or indeterminate load direction	Low loads, outer ring cannot be displaced	High requirements for running accuracy: K6, M6, N6 and P6	K7 (K6)
	Normal loads, shocks, outer ring cannot be displaced		M7 (M6)
	High loads, shocks ($C_0/P_0 < 6$), outer ring cannot be displaced		N7 (N6)
	High loads, severe shocks, thin-walled housing, outer ring cannot be displaced		P7 (P6)

¹⁾ Condition of rotation
➤ 145 | 1.

²⁾ The envelope requirement ©
➤ 168 | 11 applies.

³⁾ G7 for housings made from flake graphite cast iron, with bearing outside diameter $D > 250$ mm and temperature differential between outer ring and housing > 10 K.

⁴⁾ F7 for housings made from flake graphite cast iron, with bearing outside diameter $D > 250$ mm and temperature differential between outer ring and housing > 10 K.

5
Tolerance classes
for bearing seats in housings
(axial bearings)

Load	Bearing type	Operating conditions	Tolerance class ¹⁾ of bore
Axial load	Axial deep groove ball bearings	Normal running accuracy	E8
		High running accuracy	H6
	Axial cylindrical roller bearings with housing locating washer	–	H9
	Axial cylindrical roller and cage assemblies	–	H10
Combined loads, point load on housing locating washer	Axial spherical roller bearings	Normal loads	E8
		High loads	G7
Combined loads, circumferential load on housing locating washer		–	H7
		–	K7

¹⁾ The envelope requirement ©
➤ 168 | 11 applies.



8.4 Tables of fits

☞ *Clearance, transition and interference fits for shafts and housing bores*

Machining tolerances for shafts and housing bores are shown in ▶146 | ☞ 9, ▶150 | ☞ 6 and ▶158 | ☞ 7. The values are valid for solid steel shafts and flake graphite cast iron housings. In the table header, below the nominal diameters, are the normal tolerances for the bore or outside diameter of radial bearings (excluding tapered roller bearings). Below these are the deviations for the most important tolerance classes for mounting of rolling bearings.

☞ *Example for shaft fit, tolerance class j5*

For the shaft $\varnothing 40$ j5 ☞, ▶150 | ☞ 6 gives an example of how to read the numerical values.

☞ *Example for housing fit, tolerance class K6*

For the housing bore $\varnothing 100$ K6 ☞, ▶158 | ☞ 7 gives an example explaining the group of numbers.

6
Shaft fits

		Nominal shaft diameter in mm											
		over incl.	3 6	6 10	10 18	18 30	30 50	50 65					
		Deviations of bearing bore diameter in μm (tolerance class Normal)											
$t_{\Delta\text{dmp}}$		0 -8	0 -8	0 -8	0 -10	0 -12	0 -15						
		Shaft deviation, fit interference or fit clearance in μm											
Clearance fit	f6	-10 -18	2 7 18	-13 -22	5 11 22	-16 -27	8 15 27	-20 -33	10 17 33	-25 -41	13 22 41	-30 -49	15 26 49
		Transition fit	g5	-4 -9	4 0 9	-5 -11	3 2 11	-6 -14	2 3 14	-7 -16	3 3 16	-9 -20	3 5 20
g6	-4 -12			4 1 12	-5 -14	3 3 14	-6 -17	2 4 17	-7 -20	3 5 20	-9 -25	3 6 25	-10 -29
	h5		0 -5	8 4 5	0 -6	8 3 6	0 -8	8 3 8	0 -9	10 4 9	0 -11	12 4 11	0 -13
h6			0 -8	8 3 8	0 -9	8 2 9	0 -11	8 2 11	0 -13	10 2 13	0 -16	12 3 16	0 -19
	j5		+3 -2	11 7 2	+4 -2	12 7 2	+5 -3	13 8 3	+5 -4	15 9 4	+6 -5	18 10 5	+6 -7
j6			+6 -2	14 8 2	+7 -2	15 9 2	+8 -3	16 10 3	+9 -4	19 11 4	+11 -5	23 14 5	+12 -7
	js5		+2,5 -2,5	11 6 3	+3 -3	11 6 3	+4 -4	12 6 4	+4,5 -4,5	15 9 5	+5,5 -5,5	18 10 6	+6,5 -6,5
js6			+4 -4	12 7 4	+4,5 -4,5	13 7 5	+5,5 -5,5	14 8 6	+6,5 -6,5	17 9 7	+8 -8	20 11 8	+9,5 -9,5
	Interference fit	k5	+6 +1	14 9 1	+7 +1	15 10 1	+9 +1	17 12 1	+11 +2	21 15 2	+13 +2	25 17 2	+15 +2
k6			+9 +1	17 11 1	+10 +1	18 12 1	+12 +1	20 14 1	+15 +2	25 17 2	+18 +2	30 21 2	+21 +2
		m5	+9 +4	17 13 4	+12 +6	20 15 6	+15 +7	23 18 7	+17 +8	27 21 8	+20 +9	32 24 9	+24 +11
m6			+12 +4	20 15 4	+15 +6	23 17 6	+18 +7	26 20 7	+21 +8	31 23 8	+25 +9	37 27 9	+30 +11

Example: shaft $\varnothing 40$ j5 $\text{\textcircled{C}}$

Maximum material value	+6	18	Interference or fit clearance if the maximum material values are combined.
		10	Probable interference or fit clearance.
Minimum material value	-5	5	Interference or fit clearance if the minimum material values are combined.

Values in **bold type** in the group of three indicate fit interference, values in normal type indicate fit clearance.



65		80		100		120		140		160		180		200		220	
80		100		120		140		160		180		200		220		250	
0		0		0		0		0		0		0		0		0	
-15		-20		-20		-25		-25		-25		-30		-30		-30	
-30	15	-36	16	-36	16	-43	18	-43	18	-43	18	-50	20	-50	20	-50	20
-49	26	-58	30	-58	30	-68	34	-68	34	-68	34	-79	40	-79	40	-79	40
	49		58		58		68		68		68		79		79		79
-10	5	-12	8	-12	8	-14	11	-14	11	-14	11	-15	15	-15	15	-15	15
-23	4	-27	4	-27	4	-32	3	-32	3	-32	3	-35	2	-35	2	-35	2
	23		27		27		32		32		32		35		35		35
-10	5	-12	8	-12	8	-14	11	-14	11	-14	11	-15	15	-15	15	-15	15
-29	6	-34	6	-34	6	-39	6	-39	6	-39	6	-44	5	-44	5	-44	5
	29		34		34		39		39		39		44		44		44
0	15	0	20	0	20	0	25	0	25	0	25	0	30	0	30	0	30
-13	6	-15	8	-15	8	-18	11	-18	11	-18	11	-20	13	-20	13	-20	13
	13		15		15		18		18		18		20		20		20
0	15	0	20	0	20	0	25	0	25	0	25	0	30	0	30	0	30
-19	4	-22	6	-22	6	-25	8	-25	8	-25	8	-29	10	-29	10	-29	10
	19		22		22		25		25		25		29		29		29
+6	21	+6	26	+6	26	+7	32	+7	32	+7	32	+7	37	+7	37	+7	37
-7	12	-9	14	-9	14	-11	18	-11	18	-11	18	-13	20	-13	20	-13	20
	7		9		9		11		11		11		13		13		13
+12	27	+13	33	+13	33	+14	39	+14	39	+14	39	+16	46	+16	46	+16	46
-7	16	-9	19	-9	19	-11	22	-11	22	-11	22	-13	26	-13	26	-13	26
	7		9		9		11		11		11		13		13		13
+6,5	22	+7,5	28	+7,5	28	+9	34	+9	34	+9	34	+10	40	+10	40	+10	40
-6,5	13	-7,5	16	-7,5	16	-9	20	-9	20	-9	20	-10	23	-10	23	-10	23
	7		8		8		9		9		9		10		10		10
+9,5	25	+11	31	+11	31	+12,5	38	+12,5	38	+12,5	38	+14,5	45	+14,5	45	+14,5	45
-9,5	13	-11	17	-11	17	-12,5	21	-12,5	21	-12,5	21	-14,5	25	-14,5	25	-14,5	25
	10		11		11		13		13		13		15		15		15
+15	30	+18	38	+18	38	+21	46	+21	46	+21	46	+24	54	+24	54	+24	54
+2	21	+3	26	+3	26	+3	32	+3	32	+3	32	+4	37	+4	37	+4	37
	2		3		3		3		3		3		4		4		4
+21	36	+25	45	+25	45	+28	53	+28	53	+28	53	+33	63	+33	63	+33	63
+2	25	+3	31	+3	31	+3	36	+3	36	+3	36	+4	43	+4	43	+4	43
	2		3		3		3		3		3		4		4		4
+24	39	+28	48	+28	48	+33	58	+33	58	+33	58	+37	67	+37	67	+37	67
+11	30	+13	36	+13	36	+15	44	+15	44	+15	44	+17	50	+17	50	+17	50
	11		13		13		15		15		15		17		17		17
+30	45	+35	55	+35	55	+40	65	+40	65	+40	65	+46	76	+46	76	+46	76
+11	34	+13	42	+13	42	+15	48	+15	48	+15	48	+17	56	+17	56	+17	56
	11		13		13		15		15		15		17		17		17

6
Shaft fits

		Nominal shaft diameter in mm									
		over incl.	250 280	280 315	315 355	355 400	400 450				
		Deviations of bearing bore diameter in μm (tolerance class Normal)									
$t_{\Delta\text{dmp}}$		0 -35	0 -35	0 -35	0 -40	0 -40	0 -40	0 -40	0 -45		
		Shaft deviation, fit interference or fit clearance in μm									
Clearance fit	f6	-56 -88	21 44 88	-56 -88	21 44 88	-62 -98	22 47 98	-62 -98	22 47 98	-68 -108	23 51 108
Transition fit	g5	-17 -40	18 1 40	-17 -40	18 1 40	-18 -43	22 0 43	-18 -43	22 0 43	-20 -47	25 1 47
	g6	-17 -49	18 4 49	-17 -49	18 4 49	-18 -54	22 3 54	-18 -54	22 3 54	-20 -60	25 3 60
	h5	0 -23	35 16 23	0 -23	35 16 23	0 -25	40 18 25	0 -25	40 18 25	0 -27	45 21 27
	h6	0 -32	35 13 32	0 -32	35 13 32	0 -36	40 15 36	0 -36	40 15 36	0 -40	45 17 40
	j5	+7 -16	42 23 16	+7 -16	42 23 16	+7 -18	47 25 18	+7 -18	47 25 18	+7 -20	52 28 20
	j6	+16 -16	51 29 16	+16 -16	51 29 16	+18 -18	58 33 18	+18 -18	58 33 18	+20 -20	65 37 20
	js5	+11,5 -11,5	47 27 12	+11,5 -11,5	47 27 12	+12,5 -12,5	53 32 13	+12,5 -12,5	53 32 13	+13,5 -13,5	59 35 14
	js6	+16 -16	51 29 16	+16 -16	51 29 16	+18 -18	58 33 18	+18 -18	58 33 18	+20 -20	65 37 20
Interference fit	k5	+27 +4	62 43 4	+27 +4	62 43 4	+29 +4	69 47 4	+29 +4	69 47 4	+32 +5	77 53 5
	k6	+36 +4	71 49 4	+36 +4	71 49 4	+40 +4	80 55 4	+40 +4	80 55 4	+45 +5	90 62 5
	m5	+43 +20	78 59 20	+43 +20	78 59 20	+46 +21	86 64 21	+46 +21	86 64 21	+50 +23	95 71 23
	m6	+52 +20	87 65 20	+52 +20	87 65 20	+57 +21	97 72 21	+57 +21	97 72 21	+63 +23	108 80 23

Values in bold type in the group of three indicate fit interference, values in normal type indicate fit clearance.



450 500		500 560		560 630		630 710		710 800		800 900	
0 -45		0 -50		0 -50		0 -75		0 -75		0 -100	
-68 -108	23 51 108	-76 -120	26 58 120	-76 -120	26 58 120	-80 -130	5 47 130	-80 -130	5 47 130	-86 -146	14 39 146
-20 -47	25 1 47	-	-	-	-	-	-	-	-	-	-
-20 -60	25 3 60	-22 -66	28 4 66	-22 -66	28 4 66	-24 -74	51 9 74	-24 -74	51 9 74	-26 -82	74 24 82
0 -27	45 21 27	0 -32	50 23 32	0 -32	50 23 32	0 -36	75 38 36	0 -36	75 38 36	0 -40	100 53 40
0 -40	45 17 40	0 -44	50 18 44	0 -44	50 18 44	0 -50	75 33 50	0 -50	75 33 50	0 -56	100 48 56
+7 -20	52 28 20	-	-	-	-	-	-	-	-	-	-
+20 -20	65 37 20	-	-	-	-	-	-	-	-	-	-
+13,5 -13,5	59 35 14	+16 -16	65 38 16	+16 -16	65 38 16	+18 -18	91 55 18	+18 -18	91 55 18	+20 -20	118 72 20
+20 -20	65 37 20	+22 -22	72 40 22	+22 -22	72 40 22	+25 -25	100 58 25	+25 -25	100 58 25	+28 -28	128 76 28
+32 +5	77 53 5	-	-	-	-	-	-	-	-	-	-
+45 +5	90 62 5	+44 0	94 62 0	+44 0	94 62 0	+50 0	125 83 0	+50 0	125 83 0	+56 0	156 104 0
+50 +23	95 71 23	-	-	-	-	-	-	-	-	-	-
+63 +23	108 80 23	+70 +26	120 88 26	+70 +26	120 88 26	+80 +30	155 113 30	+80 +30	155 113 30	+90 +34	190 138 34

6
Shaft fits

Nominal shaft diameter in mm													
over incl.	3 6	6 10	10 18	18 30	30 50	50 65							
Deviations of bearing bore diameter in μm (tolerance class Normal)													
$t_{\Delta\text{dmp}}$	0 -8	0 -8	0 -8	0 -10	0 -12	0 -15							
Shaft deviation, fit interference or fit clearance in μm													
Interference fit	n5	+13 +8	21 17 8	+16 +10	24 19 10	+20 +12	28 23 12	+24 +15	34 28 15	+28 +17	40 32 17	+33 +20	48 39 20
	n6	+16 +8	24 19 8	+19 +10	27 21 10	+23 +12	31 25 12	+28 +15	38 30 15	+33 +17	45 36 17	+39 +20	54 43 20
	p6	+20 +12	28 23 12	+24 +15	32 26 15	+29 +18	37 31 18	+35 +22	45 37 22	+42 +26	54 45 26	+51 +32	66 55 32
	p7	+24 +12	32 25 12	+30 +15	38 30 15	+36 +18	44 35 18	+43 +22	53 43 22	+51 +26	63 51 26	+62 +32	77 62 32
	r6	+23 +15	31 25 15	+28 +19	36 30 19	+34 +23	42 35 23	+41 +28	51 44 28	+50 +34	62 53 34	+60 +41	75 64 41
	r7	+27 +15	35 28 15	+34 +19	42 34 19	+41 +23	49 40 23	+49 +28	59 49 28	+59 +34	71 59 34	+71 +41	86 71 41
	s6	+27 +19	35 30 19	+32 +23	40 34 23	+39 +28	47 41 28	+48 +35	58 50 35	+59 +43	71 62 43	+72 +53	87 76 53

Values in **bold type** in the group of three indicate fit interference, values in normal type indicate fit clearance.



	65	80	100	120	140	160	180	200	220
	80	100	120	140	160	180	200	220	250
	0	0	0	0	0	0	0	0	0
	-15	-20	-20	-25	-25	-25	-30	-30	-30
+33	48	58	58	70	70	70	81	81	81
+20	39	46	46	56	56	56	64	64	64
	20	23	23	27	27	27	31	31	31
+39	54	65	65	77	77	77	90	90	90
+20	43	51	51	60	60	60	70	70	70
	20	23	23	27	27	27	31	31	31
+51	66	79	79	93	93	93	109	109	109
+32	55	65	65	76	76	76	89	89	89
	32	37	37	43	43	43	50	50	50
+62	77	92	92	108	108	108	126	126	126
+32	62	73	73	87	87	87	101	101	101
	32	37	37	43	43	43	50	50	50
+62	77	93	96	113	115	118	136	139	143
+43	66	79	82	97	99	102	116	119	123
	43	51	54	63	65	68	77	80	84
+73	88	106	109	128	130	133	153	156	160
+43	73	87	90	107	109	112	128	131	135
	43	51	54	63	65	68	77	80	84
+78	93	113	121	142	150	158	181	189	199
+59	82	99	107	125	133	141	161	169	179
	59	71	79	92	100	108	122	130	140

6
Shaft fits

Nominal shaft diameter in mm											
over incl.	250 280	280 315	315 355	355 400	400 450						
Deviations of bearing bore diameter in μm (tolerance class Normal)											
$t_{\Delta\text{dmp}}$	0 -35	0 -35	0 -40	0 -40	0 -45						
Shaft deviation, fit interference or fit clearance in μm											
Interference fit	n5	+57 +34	92 73 34	+57 +34	92 73 34	+62 +37	102 80 37	+62 +37	102 80 37	+67 +40	112 88 40
		+66 +34	101 79 34	+66 +34	101 79 34	+73 +37	113 88 37	+73 +37	113 88 37	+80 +40	125 97 40
	+88 +56	123 101 56	+88 +56	123 101 56	+98 +62	138 113 62	+98 +62	138 113 62	+108 +68	153 125 68	
	+108 +56	143 114 56	+108 +56	143 114 56	+119 +62	159 127 62	+119 +62	159 127 62	+131 +68	176 139 68	
	+126 +94	161 138 94	+130 +98	165 142 98	+144 +108	184 159 108	+150 +114	190 165 114	+166 +126	211 183 126	
	+146 +94	181 152 94	+150 +98	185 156 98	+165 +108	205 173 108	+171 +114	211 179 114	+189 +126	234 198 126	
	+190 +158	225 203 158	+202 +170	237 215 170	+226 +190	266 241 190	+244 +208	284 259 208	+272 +232	317 289 232	

Values in **bold type** in the group of three indicate fit interference, values in normal type indicate fit clearance.



450 500		500 560		560 630		630 710		710 800		800 900	
0 -45		0 -50		0 -50		0 -75		0 -75		0 -100	
+67 +40	112 88 40	-	-	-	-	-	-	-	-	-	-
+80 +40	125 97 40	+88 +44	138 106 44	+88 +44	138 106 44	+100 +50	175 133 50	+100 +50	175 133 50	+112 +56	212 160 56
+108 +68	153 125 68	+122 +78	172 140 78	+122 +78	172 140 78	+138 +88	213 171 88	+138 +88	213 171 88	+156 +100	256 204 100
+131 +68	176 139 68	+148 +78	198 158 78	+148 +78	198 158 78	+168 +88	243 199 88	+168 +88	243 199 88	+190 +100	290 227 100
+172 +132	217 189 132	+194 +150	244 212 150	+199 +155	249 217 155	+225 +175	300 258 175	+235 +185	310 268 185	+266 +210	366 314 210
+195 +132	240 204 132	+220 +150	270 230 150	+225 +155	275 235 155	+255 +175	330 278 175	+265 +185	340 288 185	+300 +210	400 337 210
+292 +252	337 309 252	+324 +280	374 343 280	+354 +310	404 373 310	+390 +340	465 423 340	+430 +380	505 463 380	+486 +430	586 534 430

7
Housing fits

Nominal housing bore diameter in mm							
over incl.	6 10	10 18	18 30	18 30	18 30	18 30	
Deviations of bearing outside diameter in μm (tolerance class Normal)							
$t_{\Delta\text{Dmp}}$	0 -8	0 -8	0 -8	0 -8	0 -8	0 -8	
Housing deviation, fit interference or fit clearance in μm							
Clearance fit	E8	+47 +25	25 35 55	+59 +32	32 44 67	+73 +40	40 54 82
	F7	+28 +13	13 21 36	+34 +16	16 25 42	+41 +20	20 30 50
	G6	+14 +5	5 11 22	+17 +6	6 12 25	+20 +7	7 14 29
	G7	+20 +5	5 13 28	+24 +6	6 15 32	+28 +7	7 17 37
	H6	+9 0	0 6 17	+11 0	0 6 19	+13 0	0 7 22
	H7	+15 0	0 8 23	+18 0	0 9 26	+21 0	0 10 30
	H8	+22 0	0 10 30	+27 0	0 12 35	+33 0	0 14 42
	Transition fit	J6	+5 -4	4 2 13	+6 -5	5 1 14	+8 -5
J7		+8 -7	7 1 16	+10 -8	8 1 18	+12 -9	9 1 21
JS6		+4,5 -4,5	4,5 2 12,5	+5,5 -5,5	5,5 1 13,5	+6,5 -6,5	6,5 0 15,5
JS7		+7,5 -7,5	7,5 1 15,5	+9 -9	9 0 17	+10,5 -10,5	10,5 1 19,5
K6		+2 -7	7 1 10	+2 -9	9 3 10	+2 -11	11 4 11
K7		+5 -10	10 2 13	+6 -12	12 3 14	+6 -15	15 5 15

Example: housing $\varnothing 100$ K6 \oplus

Minimum material value	+4	18	Interference or fit clearance if the maximum material values are combined.
		6	Probable interference or fit clearance.
Maximum material value	-18	19	Interference or fit clearance if the minimum material values are combined.

Values in **bold type** in the group of three indicate fit interference, values in normal type indicate fit clearance.



30 50		50 80		80 120		120 150		150 180	
0 -11		0 -13		0 -15		0 -18		0 -25	
+89 +50	50 67 100	+106 +60	60 79 119	+126 +72	72 85 141	+148 +85	85 112 166	+148 +85	85 114 173
+50 +25	25 37 61	+60 +30	30 44 73	+71 +36	36 53 86	+83 +43	43 62 101	+83 +43	43 64 108
+25 +9	9 18 36	+29 +10	10 21 42	+34 +12	12 24 49	+39 +14	14 28 57	+39 +14	14 31 64
+34 +9	9 21 45	+40 +10	10 24 53	+47 +12	12 29 62	+54 +14	14 33 72	+54 +14	14 36 79
+16 0	0 9 27	+19 0	0 11 32	+22 0	0 12 37	+25 0	0 14 43	+25 0	0 17 50
+25 0	0 12 36	+30 0	0 14 43	+35 0	0 17 50	+40 0	0 19 58	+40 0	0 22 65
+39 0	0 17 50	+46 0	0 20 59	+54 0	0 23 69	+63 0	0 27 81	+63 0	0 29 88
+10 -6	6 3 21	+13 -6	6 5 26	+16 -6	6 6 31	+18 -7	7 7 36	+18 -7	7 10 43
+14 -11	11 1 25	+18 -12	12 2 31	+22 -13	13 4 37	+26 -14	14 5 44	+26 -14	14 8 51
+8 -8	8 1 19	+9,5 -9,5	9,5 0 22,5	+11 -11	11 1 26	+12,5 -12,5	12,5 1 30,5	+12,5 -12,5	12,5 3 37,5
+12,5 -12,5	12,5 1 23,5	+15 -15	15 1 28	+17,5 -17,5	17,5 1 32,5	+20 -20	20 1 38	+20 -20	20 1 45
+3 -13	13 4 14	+4 -15	15 4 17	+4 -18	18 6 19	+4 -21	21 7 22	+4 -21	21 4 29
+7 -18	18 6 18	+9 -21	21 7 22	+10 -25	25 8 25	+12 -28	28 9 30	+12 -28	28 6 37

 7
Housing fits

Nominal housing bore diameter in mm							
over incl.	180 250	250 315	315 400	400 500	500 630	630 800	
Deviations of bearing outside diameter in μm (tolerance class Normal)							
$t_{\Delta\text{Dmp}}$	0 -30	0 -35	0 -40	0 -45	0 -50	0 -55	
Housing deviation, fit interference or fit clearance in μm							
Clearance fit	E8	+172 +100	100 134 202	+191 +110	110 149 226	+214 +125	125 168 254
	F7	+96 +50	50 75 126	+108 +56	56 85 143	+119 +62	62 94 159
	G6	+44 +15	15 35 74	+49 +17	17 39 84	+54 +18	18 43 94
	G7	+61 +15	15 40 91	+69 +17	17 46 104	+75 +18	18 50 115
	H6	+29 0	0 20 59	+32 0	0 22 67	+36 0	0 25 76
	H7	+46 0	0 25 76	+52 0	0 29 87	+57 0	0 32 97
	H8	+72 0	0 34 102	+81 0	0 39 116	+89 0	0 43 129
	Transition fit	J6	+22 -7	7 13 52	+25 -7	7 15 60	+29 -7
J7		+30 -16	16 9 60	+36 -16	16 13 71	+39 -18	18 14 79
JS6		+14,5 -14,5	14,5 5 44,5	+16 -16	16 7 51	+18 -18	18 6 58
JS7		+23 -23	23 2 53	+26 -26	26 3 61	+28,5 -28,5	28,5 3 68,5
K6		+5 -24	24 4 35	+5 -27	27 5 40	+7 -29	29 4 47
K7		+13 -33	33 8 43	+16 -36	36 7 51	+17 -40	40 8 57

Values in **bold type** in the group of three indicate fit interference, values in normal type indicate fit clearance.



400 500		500 630		630 800		800 1000		1000 1250	
0 -45		0 -50		0 -75		0 -100		0 -125	
+232 +135	135 182 277	+255 +145	145 199 305	+285 +160	160 227 360	+310 +170	170 250 410	+360 +195	195 292 485
+131 +68	68 104 176	+146 +76	76 116 196	+160 +80	80 132 235	+176 +86	86 149 276	+203 +98	98 175 328
+60 +20	20 48 105	+66 +22	22 54 116	+74 +24	24 66 149	+82 +26	26 78 182	+94 +28	28 93 219
+83 +20	20 56 128	+92 +22	22 62 142	+104 +24	24 76 179	+116 +26	26 89 216	+133 +28	28 105 258
+40 0	0 28 85	+44 0	0 32 94	+50 0	0 42 125	+56 0	0 52 156	+66 0	0 64 191
+63 0	0 36 108	+70 0	0 40 120	+80 0	0 52 155	+90 0	0 63 190	+105 0	0 77 230
+97 0	0 47 142	+110 0	0 54 160	+125 0	0 67 200	+140 0	0 80 240	+165 0	0 97 290
+33 -7	7 21 78	-	-	-	-	-	-	-	-
+43 -20	20 16 88	-	-	-	-	-	-	-	-
+20 -20	20 8 65	+22 -22	22 10 72	+25 -25	25 17 100	+28 -28	28 24 128	+33 -33	33 31 158
+31,5 -31,5	31,5 4 76,5	+35 -35	35 5 85	+40 -40	40 12 115	+45 -45	45 18 145	+52,5 -52,5	52 24 177
+8 -32	32 4 53	0 -44	44 12 50	0 -50	50 8 75	0 -56	56 4 100	0 -66	66 2 125
+18 -45	45 9 63	0 -70	70 30 50	0 -80	80 28 75	0 -90	90 27 100	0 -105	105 28 125

7
Housing fits

Nominal housing bore diameter in mm							
over incl.	6 10	10 18	18 30				
Deviations of bearing outside diameter in μm (tolerance class Normal)							
$t_{\Delta\text{Dmp}}$	0 -8	0 -8	0 -8	0 -9			
Housing deviation, fit interference or fit clearance in μm							
Transition fit	M6	-3 -12	12 6 5	-4 -15	15 9 4	-4 -17	17 10 5
	M7	0 -15	15 7 8	0 -18	18 9 8	0 -21	21 11 9
	N6	-7 -16	16 10 1	-9 -20	20 14 1	-11 -24	24 17 2
	N7	-4 -19	19 11 4	-5 -23	23 14 3	-7 -28	28 18 2
Interference fit	P6	-12 -21	21 15 4	-15 -26	26 20 7	-18 -31	31 24 9
	P7	-9 -24	24 16 1	-11 -29	29 20 3	-14 -35	35 25 5

Values in **bold type** in the group of three indicate fit interference, values in normal type indicate fit clearance.



30		50		80		120		150	
50		80		120		150		180	
0		0		0		0		0	
-11		-13		-15		-18		-25	
-4	20	-5	24	-6	28	-8	33	-8	33
-20	11	-24	13	-28	16	-33	19	-33	16
	7		8		9		10		17
0	25	0	30	0	35	0	40	0	40
-25	13	-30	16	-35	18	-40	21	-40	18
	11		13		15		18		25
-12	28	-14	33	-16	38	-20	45	-20	45
-28	19	-33	22	-38	26	-45	31	-45	28
	1		1		1		2		5
-8	33	-9	39	-10	45	-12	52	-12	52
-33	21	-39	25	-45	28	-52	33	-52	30
	3		4		5		3		13
-21	37	-26	45	-30	52	-36	61	-36	61
-37	28	-45	34	-52	40	-61	47	-61	44
	10		13		15		18		11
-17	42	-21	51	-24	59	-28	68	-28	68
-42	30	-51	37	-59	42	-68	49	-68	46
	6		8		9		10		3

7
Housing fits

Nominal housing bore diameter in mm							
over incl.	180 250	250 315	315 400	400 500	500 630	630 800	
Deviations of bearing outside diameter in μm (tolerance class Normal)							
$t_{\Delta\text{Dmp}}$	0 -30	0 -35	0 -41	0 -46	0 -52	0 -60	
Housing deviation, fit interference or fit clearance in μm							
Transition fit	M6	-8 -37	37 17 22	-9 -41	41 19 26	-10 -46	46 21 30
	M7	0 -46	46 21 30	0 -52	52 23 35	0 -57	57 25 40
	N6	-22 -51	51 31 8	-25 -57	57 35 10	-26 -62	62 37 14
	N7	-14 -60	60 35 16	-14 -66	66 37 21	-16 -73	73 41 24
Interference fit	P6	-41 -70	70 50 11	-47 -79	79 57 12	-51 -87	87 62 11
	P7	-33 -79	79 54 3	-36 -88	88 59 1	-41 -98	98 66 1

Values in **bold type** in the group of three indicate fit interference, values in normal type indicate fit clearance.



400		500		630		800		1000	
500		630		800		1000		1250	
0		0		0		0		0	
-45		-50		-75		-100		-125	
-10	50	-26	70	-30	80	-34	90	-40	106
-50	22	-70	38	-80	38	-90	38	-106	45
	35		24		45		66		85
0	63	-26	96	-30	110	-34	124	-40	145
-63	27	-96	56	-110	58	-124	61	-145	68
	45		24		45		66		85
-27	67	-44	88	-50	100	-56	112	-66	132
-67	39	-88	56	-100	58	-112	60	-132	67
	18		6		25		44		59
-17	80	-44	114	-50	130	-56	146	-66	171
-80	44	-114	74	-130	78	-146	83	-171	94
	28		6		25		44		59
-55	95	-78	122	-88	138	-100	156	-120	186
-95	67	-122	90	-138	96	-156	104	-186	121
	10		28		13		0		5
-45	108	-78	148	-88	168	-100	190	-120	225
-108	72	-148	108	-168	126	-190	127	-225	148
	0		28		13		0		5

Shaft tolerances for adapter sleeves and withdrawal sleeves are shown in **▶ 166** | **8**.

8
Shaft tolerances
for adapter sleeves and
withdrawal sleeves

The numbers printed in italics
give guide values
for the cylindricity tolerance t_1
(DIN EN ISO 1101) **▶ 168** | **11**.

Nominal shaft diameter		Shaft tolerance					
		$h7 / \frac{IT5}{2}$		$h8 / \frac{IT5}{2}$		$h9 / \frac{IT6}{2}$	
mm		μm		μm		μm	
over	incl.						
3	6	0 -12	2,5	0 -18	2,5	0 -30	4
6	10	0 -15	3	0 -22	3	0 -36	4,5
10	18	0 -18	4	0 -27	4	0 -43	5,5
18	30	0 -21	4,5	0 -33	4,5	0 -52	6,5
30	50	0 -25	5,5	0 -39	5,5	0 -62	8
50	65	0 -30	6,5	0 -46	6,5	0 -74	9,5
65	80	0 -30	6,5	0 -46	6,5	0 -74	9,5
80	100	0 -35	7,5	0 -54	7,5	0 -87	11
100	120	0 -35	7,5	0 -54	7,5	0 -87	11
120	140	0 -40	9	0 -63	9	0 -100	12,5
140	160	0 -40	9	0 -63	9	0 -100	12,5
160	180	0 -40	9	0 -63	9	0 -100	12,5
180	200	0 -46	10	0 -72	10	0 -115	14,5
200	220	0 -46	10	0 -72	10	0 -115	14,5
220	250	0 -46	10	0 -72	10	0 -115	14,5
250	280	0 -52	11,5	0 -81	11,5	0 -130	16
280	315	0 -52	11,5	0 -81	11,5	0 -130	16
315	355	0 -57	12,5	0 -89	12,5	0 -140	18
355	400	0 -57	12,5	0 -89	12,5	0 -140	18
400	450	0 -63	13,5	0 -97	13,5	0 -155	20
450	500	0 -63	13,5	0 -97	13,5	0 -155	20
500	560	0 -70	16	0 -110	16	0 -175	22
560	630	0 -70	16	0 -110	16	0 -175	22
630	710	0 -80	18	0 -125	18	0 -200	25
710	800	0 -80	18	0 -125	18	0 -200	25
800	900	0 -90	20	0 -140	20	0 -230	28



8.5 Enveloping circle

For bearings without an inner ring, the enveloping circle F_w ▶ 167 | 10 is used. This is the inner inscribed circle of the rolling elements in clearance-free contact with the outer raceway. The enveloping circle for unfitted machined needle roller bearings is in the tolerance class F6 and for drawn cup needle roller bearings in the tolerance class F8. Deviations for F6 and F8 ▶ 167 | 9.

10 Enveloping circle

F_w = enveloping circle diameter

- ① Rolling element
- ② Outer raceway

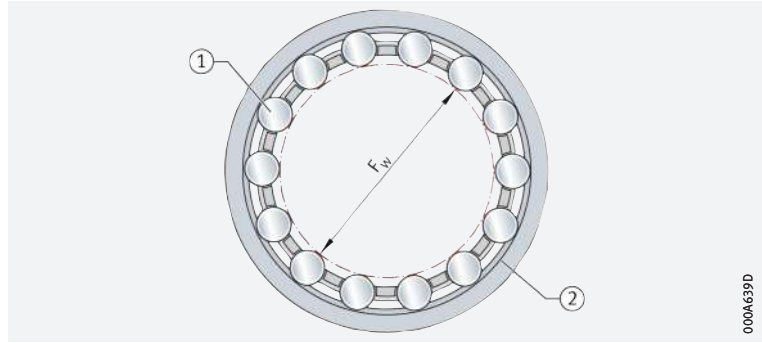

000A639D

9 Deviations for the enveloping circle diameter

Enveloping circle diameter F_w mm		Tolerance class F6		Tolerance class F8	
		Tolerance for enveloping circle diameter F_w		Tolerance for enveloping circle diameter F_w	
over	incl.	Upper deviation μm	Lower deviation μm	Upper deviation μm	Lower deviation μm
3	6	+18	+10	+28	+10
6	10	+22	+13	+35	+13
10	18	+27	+16	+43	+16
18	30	+33	+20	+53	+20
30	50	+41	+25	+64	+25
50	80	+49	+30	+76	+30
80	120	+58	+36	+90	+36
120	180	+68	+43	+106	+43
180	250	+79	+50	+122	+50
250	315	+88	+56	+137	+56
315	400	+98	+62	+151	+62
400	500	+108	+68	+165	+68

8.6 Dimensional, geometrical and running accuracy of mating parts



In order to achieve the required fit, the bearing seats and fit surfaces of the shaft and housing bore must conform to certain tolerances
 ➤ 168 | □ 11 and ➤ 169 | ▨ 10.

11

Guide values for the geometrical and positional tolerances of bearing seating surfaces

- t_1 = roundness tolerance
- t_2 = parallelism tolerance
- t_3 = total axial runout tolerance of abutment shoulders
- t_4 = coaxiality tolerance

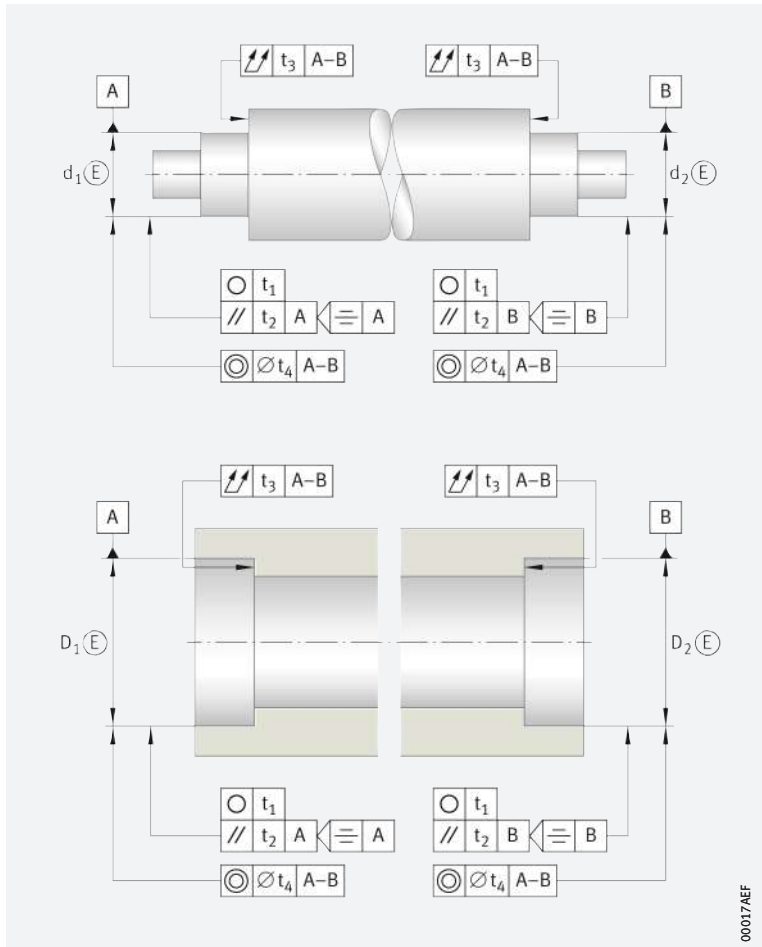

Accuracy of bearing seating surfaces

- ISO fundamental tolerances
 The degree of accuracy for the bearing seat tolerances on the shaft and in the housing, as well as the ISO fundamental tolerances, are shown in ➤ 169 | ▨ 10 (DIN ISO 286-1:2010).
- Second bearing seat
 The positional tolerances t_4 for a second bearing seat on the shaft (d_2) or in the housing (D_2) are dependent on the types of bearings used and the operating conditions. For the values required in the specific application, please consult Schaeffler.
- Housings
 In split housings, the joints must be free from burrs. The accuracy of the bearing seats is determined as a function of the accuracy of the bearing selected.



10

Guide values for the geometrical and positional tolerances of bearing seating surfaces

Bearing tolerance class		Bearing seating surface	Fundamental tolerance grades ¹⁾			
to ISO 492	to DIN 620		Diameter tolerance	Roundness tolerance	Parallelism tolerance	Total axial runout tolerance of abutment shoulder
				t ₁	t ₂	t ₃
Normal 6X	PN (P0) P6X	Shaft	IT6 (IT5)	Circumferential load IT4/2	Circumferential load IT4/2	IT4
				Point load IT5/2	Point load IT5/2	
		Housing	IT7 (IT6)	Circumferential load IT5/2	Circumferential load IT5/2	IT5
				Point load IT6/2	Point load IT6/2	
6	P6	Shaft	IT5	Circumferential load IT3/2	Circumferential load IT3/2	IT3
				Point load IT4/2	Point load IT4/2	
		Housing	IT6	Circumferential load IT4/2	Circumferential load IT4/2	IT4
				Point load IT5/2	Point load IT5/2	
5	P5	Shaft	IT5	Circumferential load IT2/2	Circumferential load IT2/2	IT2
				Point load IT3/2	Point load IT3/2	
		Housing	IT6	Circumferential load IT3/2	Circumferential load IT3/2	IT3
				Point load IT4/2	Point load IT4/2	
4	P4 P4S ²⁾ SP ²⁾	Shaft	IT4	Circumferential load IT1/2	Circumferential load IT1/2	IT1
				Point load IT2/2	Point load IT2/2	
		Housing	IT5	Circumferential load IT2/2	Circumferential load IT2/2	IT2
				Point load IT3/2	Point load IT3/2	
	UP ²⁾	Shaft	IT3	Circumferential load IT0/2	Circumferential load IT0/2	IT0
				Point load IT1/2	Point load IT1/2	
		Housing	IT4	Circumferential load IT1/2	Circumferential load IT1/2	IT1
				Point load IT2/2	Point load IT2/2	

¹⁾ ISO fundamental tolerances (IT grades) in accordance with DIN ISO 286. Values for IT grades ▶ 170 | 12.

²⁾ Not included in DIN 620.

Roughness of bearing seats

Ra must not be too high

The roughness of the bearing seats must be matched to the tolerance class of the bearings. The mean roughness value Ra must not be too high, in order to maintain the interference loss within limits. Shafts must be ground, while bores must be precision turned. For further information on this subject ▶ 170 | 11 and product chapter.

11
 Roughness values
 for cylindrical bearing seating
 surfaces – guide values

¹⁾ For the mounting of bearings using the hydraulic method, a value $Ra = 1,6 \mu\text{m}$ must not be exceeded

Nominal diameter of bearing seat d (D) mm		Recommended mean roughness value for ground bearing seats Ramax			
		μm			
		Diameter tolerance (IT grade)			
over	incl.	IT7	IT6	IT5	IT4
–	80	1,6	0,8	0,4	0,2
80	500	1,6	1,6	0,8	0,4
500	1 250	3,2 ¹⁾	1,6	1,6	0,8

Numerical values for IT grades



► 170 | **12** shows numerical values for the ISO fundamental tolerances (IT grades) in accordance with DIN ISO 286-1:2010.

12
 IT grades and values

IT grade	Nominal dimension in mm							
	over –	3	6	10	18	30	50	80
	incl. 3	6	10	18	30	50	80	120
Values in μm								
IT01	0,3	0,4	0,4	0,5	0,6	0,6	0,8	1
IT0	0,5	0,6	0,6	0,8	1	1	1,2	1,5
IT1	0,8	1	1	1,2	1,5	1,5	2	2,5
IT2	1,2	1,5	1,5	2	2,5	2,5	3	4
IT3	2	2,5	2,5	3	4	4	5	6
IT4	3	4	4	5	6	7	8	10
IT5	4	5	6	8	9	11	13	15
IT6	6	8	9	11	13	16	19	22
IT7	10	12	15	18	21	25	30	35
IT8	14	18	22	27	33	39	46	54
IT9	25	30	36	43	52	62	74	87
IT10	40	48	58	70	84	100	120	140
IT11	60	75	90	110	130	160	190	220
IT12	100	120	150	180	210	250	300	350

continued ▼

12
 IT grades and values

IT grade	Nominal dimension in mm							
	over 120	180	250	315	400	500	630	800
	incl. 180	250	315	400	500	630	800	1 000
Values in μm								
IT01	1,2	2	2,5	3	4	–	–	–
IT0	2	3	4	5	6	–	–	–
IT1	3,5	4,5	6	7	8	9	10	11
IT2	5	7	8	9	10	11	13	15
IT3	8	10	12	13	15	16	18	21
IT4	12	14	16	18	20	22	25	28
IT5	18	20	23	25	27	32	36	40
IT6	25	29	32	36	40	44	50	56
IT7	40	46	52	57	63	70	80	90
IT8	63	72	81	89	97	110	125	140
IT9	100	115	130	140	155	175	200	230
IT10	160	185	210	230	250	280	320	360
IT11	250	290	320	360	400	440	500	560
IT12	400	460	520	570	630	700	800	900

continued ▲



Seats for adapter sleeves and withdrawal sleeves

☞ *Seat diameter tolerances for adapter sleeves and withdrawal sleeves*

Adapter and withdrawal sleeves are used if increased requirements are not made on the running accuracy of the bearing. For the seats, diameter tolerances corresponding to the IT grades 7 to 9 are possible, while the geometrical deviation can be 50% of this value.

Tapered bearing seats for radial bearings

☞ *Geometrical and positional tolerances of the shaft*

Guide values for the machining of tapered bearing seats on shafts are shown in ► 171 | 12, ► 171 | 13.



This information does not apply to super precision cylindrical roller bearings in machine tools (spindle bearing arrangement). For information on this subject, see the catalogue Super Precision Bearings ► SP 1.

☞ *Taper gauges*

Schaeffler taper gauges can be used to check for adherence to the recommended tolerances.



12
Guide values for the geometrical and positional tolerances of tapered bearing seats

- B = bearing width
- SL = L · taper ratio (1:12, 1:30)
- $t_{\Delta SL}'$ = taper angle tolerance
- t_1 = roundness tolerance
► 169 | 10
- t_6 = perpendicularity tolerance
= $2/3 \cdot t_2$;
values for t_2 ► 169 | 10
- z = recommended mean roughness ► 170 | 11

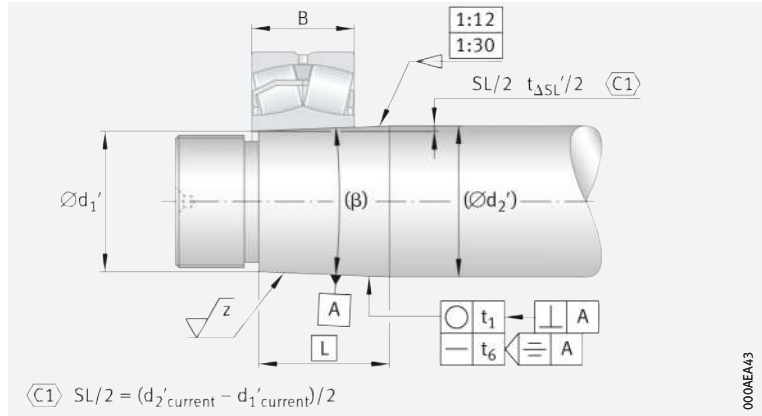

000ME43

The tolerances for taper angle $t_{\Delta SL}$ relative to the bearing width B can be found in the table ► 171 | 13.



13
Taper angle tolerance of tapered bearing seats, relative to bearing width

Bearing width B (nominal dimension)		Taper angle tolerance $t_{\Delta SL}$			
		from		to	
mm		Deviations			
over	incl.	upper μm	lower μm	upper μm	lower μm
16	25	+8	0	+12,5	0
25	40	+10	0	+16	0
40	63	+12,5	0	+20	0
63	100	+16	0	+25	0
100	160	+20	0	+32	0
160	250	+25	0	+40	0
250	400	+32	0	+50	0
400	630	+40	0	+63	0

☞ *Determine $t_{\Delta SL}$ by means of interpolation*

For bearing widths with nominal dimensions between the values listed in the table, the taper angle tolerance $t_{\Delta SL}$ should be determined by means of interpolation of the upper deviations ► 171 | f1.



f1
Interpolation of the taper angle tolerance

$$t_{\Delta SL} = \frac{\Delta t_{\Delta SL}}{\Delta B} \cdot B$$

For a taper of length L, the taper angle tolerance $t_{\Delta SL}'$ of the entire taper applies ► 171 | f2.



f2
Taper angle tolerance of the entire taper

$$t_{\Delta SL}' = \frac{t_{\Delta SL}}{B} \cdot L = \frac{\Delta t_{\Delta SL}}{\Delta B} \cdot L$$

Example of tolerance calculation

Given:

- bearing width B = 90 mm
- taper ratio 1:12
- taper length L = 100 mm.



$$t_{\Delta SL}' = \frac{25 \mu\text{m} - 16 \mu\text{m}}{100 \text{ mm} - 63 \text{ mm}} \cdot 100 \text{ mm} = \frac{9 \mu\text{m}}{37 \text{ mm}} \cdot 100 \text{ mm} \approx 24 \mu\text{m}$$

The tolerance $t_{\Delta SL}'/2$ is thus 0 to +12 μm .

In order to calculate the taper slope SL (nominal dimension), the taper length L is multiplied by the taper ratio (1:12) ► 172 | f13.

f13
Taper slope

$$SL = L \cdot \frac{1}{12}$$



$$SL = 100 \text{ mm} \cdot \frac{1}{12} = 8,333 \text{ mm}$$

The nominal dimension for SL/2 is thus 4,166 mm; SL/2 = 4,166 +0,012/0.

The data can then be entered in the drawing as follows ► 172 | 13.

13
Example of drawing entry
for dimensional tolerances

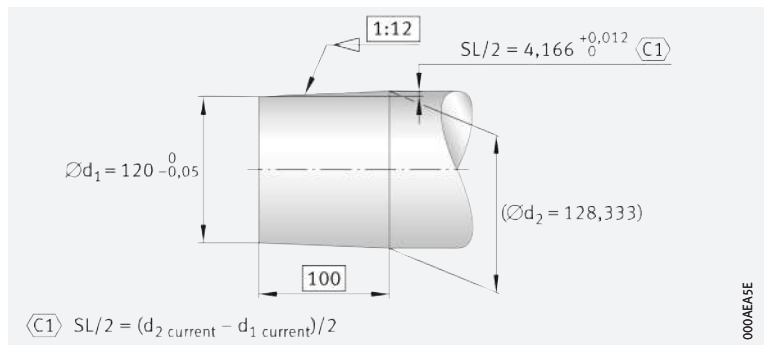

Checking of a shaft

Measured values:

- $d_1' = 120 \text{ mm}$
- $d_2' = 128,345 \text{ mm}$.

The taper slope is calculated from the measured values using ► 172 | f14.

f14
Taper slope

$$\frac{SL}{2} = \frac{d_2' - d_1'}{2}$$



$$\frac{SL}{2} = \frac{128,345 \text{ mm} - 120 \text{ mm}}{2} = 4,173 \text{ mm}$$

The value for SL/2 is thus within tolerance.



8.7 Axial location of bearings

Securing the bearing rings against axial creep by means of form fit

In order to prevent the bearing rings co-rotating, they are radially fixed by means of a tight fit. At the same time, the rings must be axially located in both directions so that they cannot undergo lateral creep. Axial creep cannot be prevented solely by a tight fit, especially not if a radial bearing must support large axial forces. For axial location, the bearing rings must therefore be connected by form fit to the shaft or the housing.

Examples

Solutions proven in practice for individual bearing arrangements (locating bearing arrangement, non-locating bearing arrangement, adjusted/floating bearing arrangement) and the axial location of bearing rings in certain bearing types are described below. Specific features of the individual bearing types are covered in the product chapters.

Guidelines for axial location of bearing rings

Locating bearing arrangement

Locating bearings can support axial forces in both directions

Locating bearings must in general also support axial forces. For the axial location of bearing rings, form fit elements such as shoulders, snap rings, covers, caps, nuts etc. have proved effective.

► 173 | 14 shows bearing types that can be used as locating bearings and can support axial forces in both directions. The arrows in ► 173 | 14 to ► 175 | 16 indicate what task the axial location methods perform in the various types of mounting and types of bearing, such as axial location on both sides of the outer and inner ring of the deep groove ball bearing.



In locating bearing arrangements, both bearing rings must always be abutted on both sides. The fasteners must be matched to the magnitude of the axial forces present.



14 Axial location of bearing rings in locating bearings

↔ = the means of location must support significant axial forces

- ① Cylindrical roller bearing NUP
- ② Deep groove ball bearing
- ③ Spherical roller bearing
- ④ Angular contact ball bearing pair
- ⑤ Double direction axial deep groove ball bearing

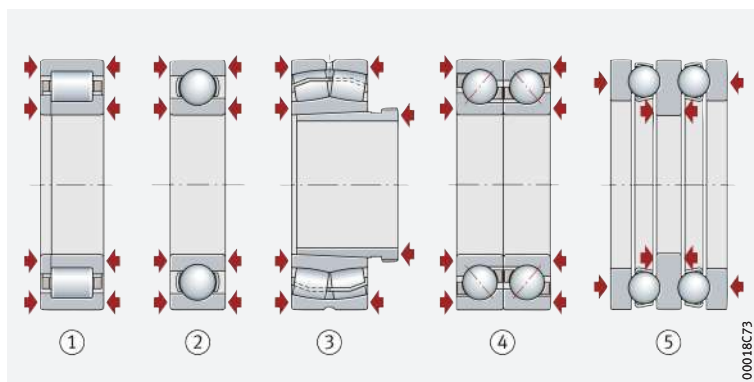

Cylindrical roller bearing, deep groove ball bearing

The cylindrical roller bearing NUP and deep groove ball bearing support alternating axial forces. Both rings must therefore be axially located on both sides.

Spherical roller bearing

The spherical roller bearing must, as a locating bearing, support axial forces from alternating directions. In this example, the inner ring is located by means of a withdrawal sleeve.

Angular contact ball bearings

The pair of angular contact ball bearings forms a locating bearing in which the two single row bearings are adjusted against each other in mounting. For location on the shaft, readjustable fasteners, such as nuts, are suitable.

Double direction axial deep groove ball bearing

The double direction axial deep groove ball bearing should be seen as a closed bearing group. The shaft locating washer is axially located on both sides, while the housing locating washers are each located on one side. In order that the ball and cage assemblies are guided correctly in the raceway grooves, the bearing is mounted clearance-free by adjustment of the housing locating washers.

The means of axial location only needs to prevent lateral creep of the bearing rings

Non-locating bearing arrangement

Non-locating bearings must only support slight axial forces. The axial location method only needs to prevent lateral creep of the rings. The simplest way of achieving this is by a tight fit. In the case of non-separable bearings, the rotating bearing ring has a tight fit. The other ring is axially retained by the rolling elements. ▶ 174 | 15 shows rolling bearings that can be used as non-locating bearings.

15

Axial location of bearing rings in non-locating bearings

- ↔ = the means of location must prevent axial creep of the ring
- ← = the means of location must support significant axial forces

- 1 Cylindrical roller bearing NU
- 2 Deep groove ball bearing
- 3 Spherical roller bearing
- 4 Barrel roller bearing
- 5 Two single row angular contact ball bearings, adjusted in a pair

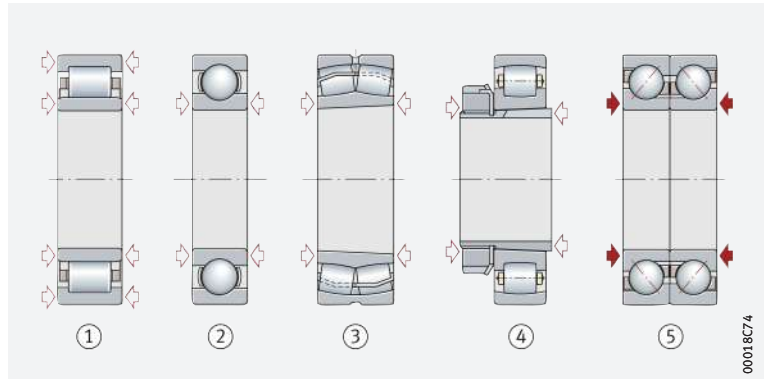

Cylindrical roller bearing NU

The cylindrical roller bearing NU is designed such that the inner ring can be displaced relative to the roller and cage assembly. For this reason, both bearing rings must also be secured against axial creep on both sides.

Deep groove ball bearing

In the deep groove ball bearing, only the inner ring is located, while the outer ring is axially retained by the rolling elements.

Spherical roller bearing, barrel roller bearing, angular contact ball bearings

In the spherical roller bearing and barrel roller bearing, as well as in the angular contact ball bearing pair, the outer ring is guided axially by the rolling elements. The inner ring of the barrel roller bearing is located on the shaft with or without an adapter sleeve. Location by means of an adapter sleeve secures the bearing against lateral creep.

Adjusted single row angular contact ball bearings

In the adjusted pair of single row angular contact ball bearings, the inner rings are clamped against each other so that they are not forced apart by the axial component of the radial force.

Adjusted or floating bearing arrangement

The bearings can support axial loads in one direction only

Bearings mounted in an adjusted and floating arrangement can support axial load in one direction only; this also applies to single direction axial bearings. The axial forces are supported by shaft or housing shoulders, snap rings, covers etc.

Angular contact ball bearing, cylindrical roller bearing

The angular contact ball bearing in ▶ 175 | 16 supports axial forces in one direction only. The bearing rings therefore only require abutment on one side each in accordance with the force pattern.

Axial deep groove ball bearing

The axial force component is supported by an additional bearing in a mirror image arrangement. Similar conditions are present in the cylindrical roller bearing NJ.

The balls in the axial deep groove ball bearing in ▶ 175 | 16 only roll correctly if the bearing runs clearance-free and with adequate minimum load.



If the shaft is horizontal, a further adjustable bearing must be provided. This is particularly important in the case of high speeds. If the shaft is vertical, the opposing bearing can be omitted if the bearing is adjusted clearance-free by the load in all operating states.



16

Axial location of the bearing rings in bearings in an adjusted or floating bearing arrangement

◄ = the means of location must support significant axial forces

- ① Angular contact ball bearing
- ② Cylindrical roller bearing NJ
- ③ Axial deep groove ball bearing

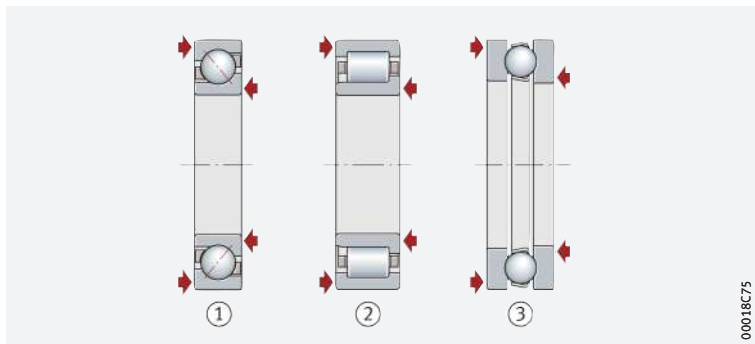

00018C75

Examples of the axial fixing of bearing rings

☞ *Axial location of bearing rings*

► 175 | 17 to ► 179 | 24 show possibilities for the location of bearing rings depending on the design of the bearing arrangement and the application.

☞ *Deep groove ball bearing and cylindrical roller bearing*

☞ *Locating bearing A*

Locating/non-locating bearing arrangement

► 175 | 17 shows the bearing arrangement of the shaft in an electric motor of medium power rating.

The locating bearing A is subjected not only to radial forces but also to axial forces of alternating direction. The axial forces are not very high and do not act in a shock type manner. For location of the deep groove ball bearing, rigid shoulders, covers, snap rings or other form fit elements are therefore normally used. The adjacent parts should require little production work and mounting and dismantling should be easy to perform.

☞ *Non-locating bearing B*

The non-locating bearing B must support radial forces only. The outer ring is clamped between the snap ring and cover, while the inner ring has a tight fit on the shaft.

17

Axial location of deep groove ball bearing and cylindrical roller bearing

A = locating bearing
B = non-locating bearing

- ① Deep groove ball bearing
- ② Cylindrical roller bearing NU
- ③ Snap ring
- ④ Spacer ring
- ⑤ Cover

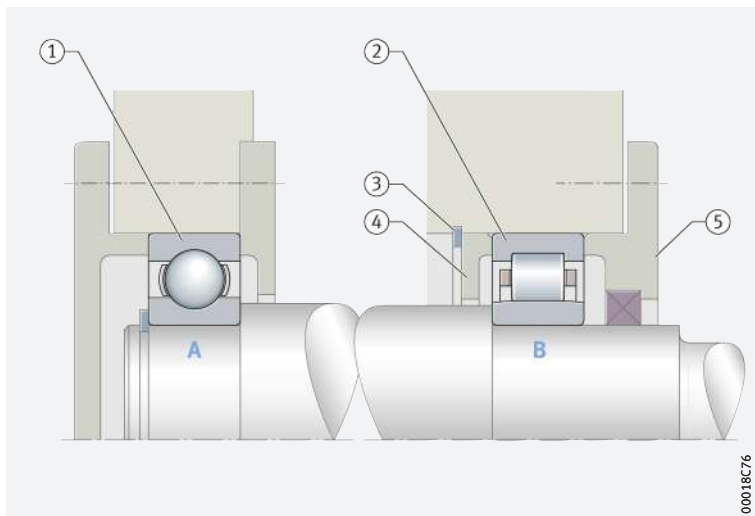

00018C76

🔧 *Tapered roller bearing pair and cylindrical roller bearing*

🔧 *Locating bearing A*

🔧 *Non-locating bearing B*

Locating/non-locating bearing arrangement

The bearing arrangement of a pinion shaft shown in ▶ 176 | 18 is subjected to high, occasionally shock type radial and axial forces. Due to the hypoid tooth set, precise axial adjustment of the pinion against the crown gear and rigid guidance are necessary.

The locating bearing A is formed by the tapered roller bearing pair clamped from within. Since spacer rings are arranged between the inner rings, the shaft nut can be tightened to a certain torque without leading to bracing of the bearing arrangement. The axial position of the pinion relative to the crown gear is set by means of shims at the time of mounting.

The non-locating bearing B must support radial forces only. Due to the magnitude of the forces, both rings have tight fits. A snap ring in one annular slot of the outer ring securely prevents creep of the bearing to the left. The ribs of the bearing rings represent additional security against creep to the right. In order to prevent jamming of the bearing arrangement, the non-locating bearing must have axial clearance between the inner ring rib and the rollers.

18
Axial location of tapered roller bearing pair and cylindrical roller bearing

A = locating bearing

B = non-locating bearing

- ① Pair of tapered roller bearings
- ② Cylindrical roller bearing
- ③ Snap ring
- ④ Spacer ring
- ⑤ Shims
- ⑥ Shaft nut

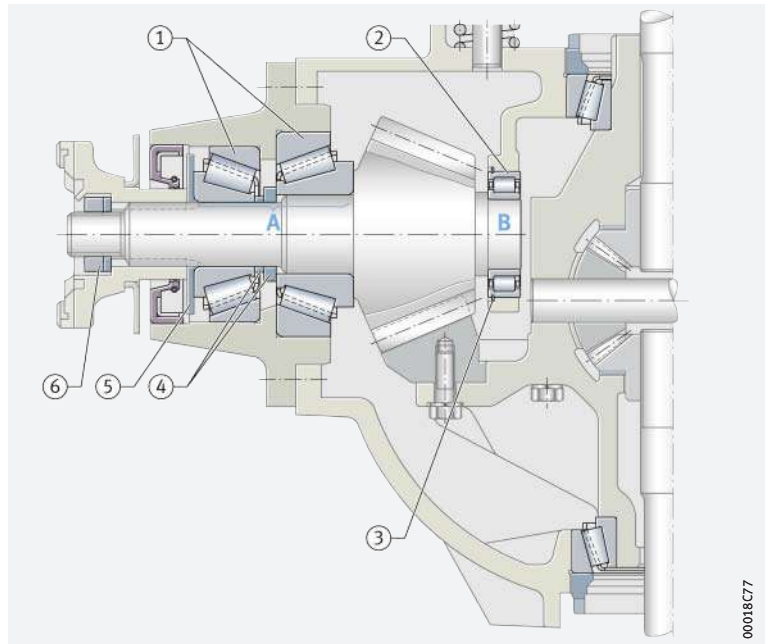

00018C77



🔗 Cylindrical roller bearing and axial deep groove ball bearing

Locating bearing arrangement

The locating bearing in ▶ 177 | 19 is subjected to high axial forces in both directions and the shaft must be guided axially clearance-free.

The shaft locating washer of the double direction axial deep groove ball bearing and the inner ring of the cylindrical roller bearing are axially clamped by means of an end washer. The axial deep groove ball bearing is adjusted clearance-free by means of the intermediate ring inserted with a fit.

19

Axial location of axial deep groove ball bearing and cylindrical roller bearing

- ① Housing locating washer of axial deep groove ball bearing, double direction
- ② Cylindrical roller bearing NU
- ③ Spacer ring
- ④ Intermediate ring inserted with fit
- ⑤ End washer
- ⑥ Shaft locating washer of axial deep groove ball bearing

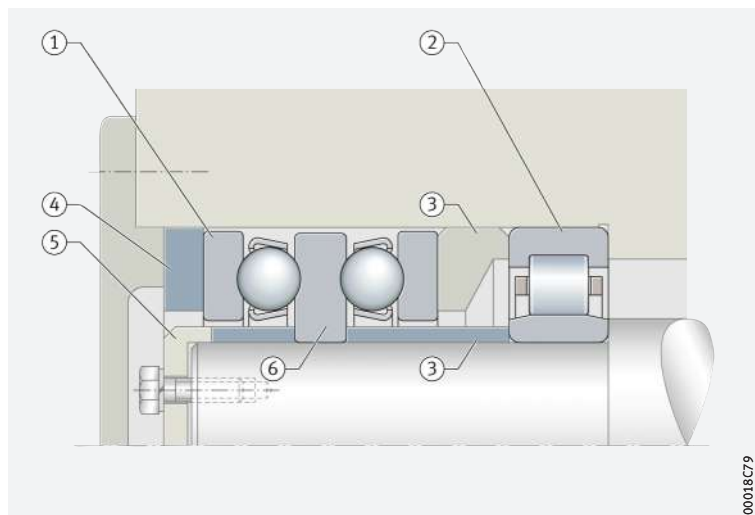

00018C79

🔗 Spherical roller bearing

Locating bearing arrangement

▶ 177 | 20 shows the locating bearing for a conveyor sheave. In order that the bearing can be mounted and dismantled with ease, a withdrawal sleeve is used to locate the inner ring, which is pressed in using a hydraulic mounting method. The taper on the withdrawal sleeve is self-retaining. The end cap serves as a retainer only.

20

Axial location of spherical roller bearing with withdrawal sleeve

- ① Spherical roller bearing
- ② Cover
- ③ Withdrawal sleeve
- ④ End cap
- ⑤ Spacer bush with labyrinth passages

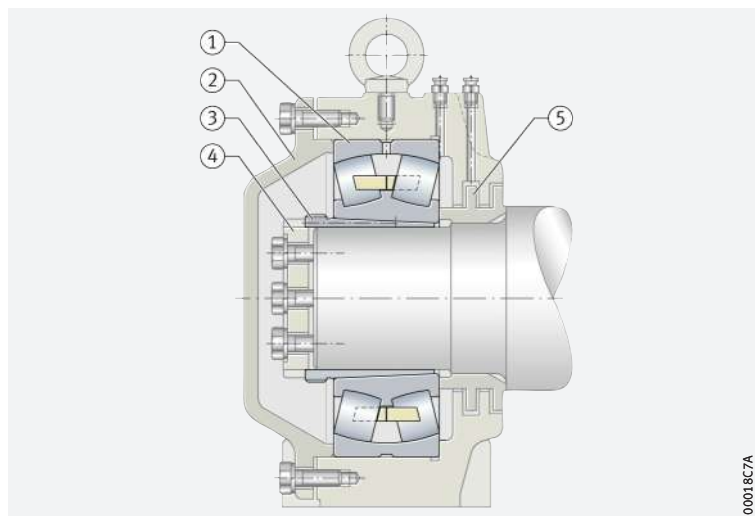

00018C7A

Radial deep groove ball bearing and axial deep groove ball bearing

Locating bearing arrangement for vertical shaft

The vertical shaft in ► 178 | 21 is radially guided by a radial deep groove ball bearing and axially supported by an axial deep groove ball bearing. Disc springs fixed by means of a snap ring give axial preload of the bearing, thus ensuring the minimum load for the guidance bearing. There is some axial clearance between the disc spring when pressed flat and the snap ring. This gives easier mounting of the snap ring. In order to ensure a minimum load for the axial bearing in the event of thrust reversal, biasing springs are attached to the housing locating washer.

21
Axial location of an axial and radial deep groove ball bearing with a vertical shaft

- ① Radial deep groove ball bearing
- ② Axial deep groove ball bearing
- ③ Snap ring
- ④ Disc spring
- ⑤ Helical compression spring

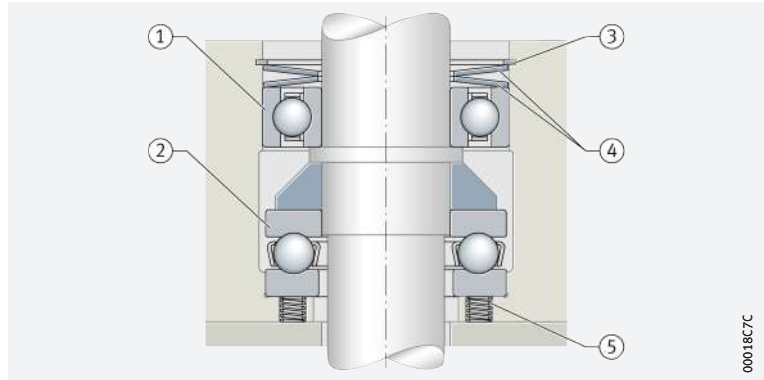

00018C7C

Spherical roller bearing, location by adapter sleeve

Non-locating bearing arrangement

The locating bearing in ► 178 | 22 must support high radial loads. When the adapter sleeve is tightened, this gives the bearing on the smooth shaft a tight fit, which prevents axial creep.

22
Axial location of spherical roller bearing with adapter sleeve

- ① Spherical roller bearing
- ② Locknut with tab washer
- ③ Adapter sleeve

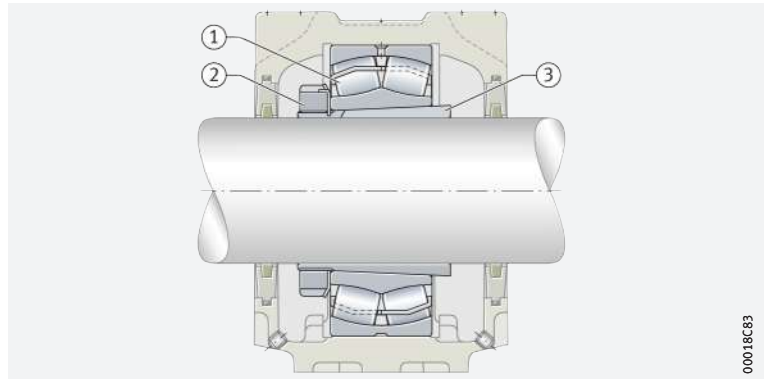

00018C83

Tapered roller bearing pair, bearings in O arrangement, outer rings with tight fit

Adjusted bearing arrangement

In wheel bearing arrangements with a rotating outer ring in accordance with ► 179 | 23, not only are high radial and axial forces present but tilting moments also occur. The outer rings have a tight fit. In these sorts of hub bearing arrangements, this is important due to the circumferential load acting on the outer rings. The axial clearance of the bearing group is set by means of the fixing nut, where the loosely fitted inner ring of the outer bearing undergoes displacement.



23

Axial location of tapered roller bearing pair

H = support spacing

- ① Tapered roller bearing pair, O arrangement
- ② Fixing nut

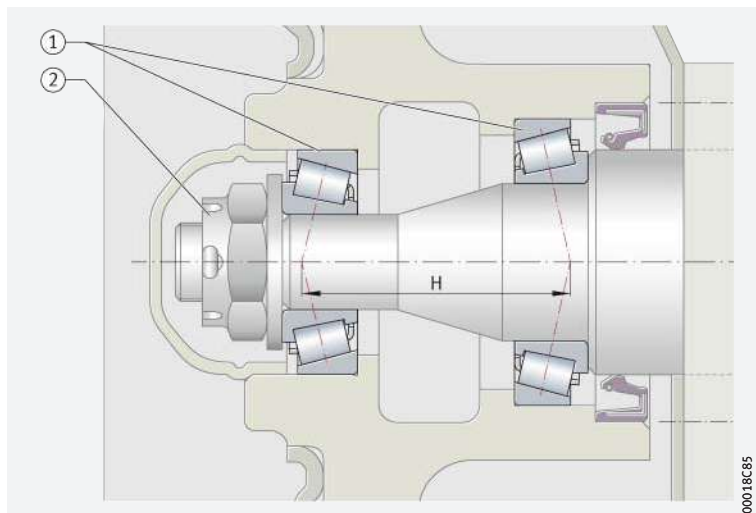

00018C85

Deep groove ball bearings

Inner rings with tight fit, outer rings with sliding seat, bearings adjusted by means of spring preload

Spherical roller bearings

Adjusted bearing arrangement with spring washer

The example in ▶143|② 7 shows a bearing arrangement that is commonly used in small electric motors. The bearings are not subjected to high loads, the speed is in the moderate range. The radial load is small and only guidance forces must be supported in an axial direction.

The inner rings of the deep groove ball bearings have a tight fit on the journal and are abutted on the shaft shoulders. The outer rings have a sliding seat. A spring washer is fitted between the outer ring of the right hand bearing and the cover collar. The bearings are axially adjusted by the tensioned springs. This achieves particularly smooth running.

Floating bearing arrangement

▶179|② 24 shows the bearing arrangement of a heavy support roller. The bearings are subjected to high radial loads. In addition, a frictional force acts axially on the outside surface of the support roller. Close axial guidance is not required and, as a result, a floating bearing arrangement can be selected. In the course of this, the lateral movement of the outer rings is restricted by the contact in the housing. Both housings are split. The axial displacement distance s can be measured with the upper section removed.

24

Axial location of two spherical roller bearings

s = axial displacement distance

- ① Spherical roller bearing
- ② Cover
- ③ Spacer bush with labyrinth passages

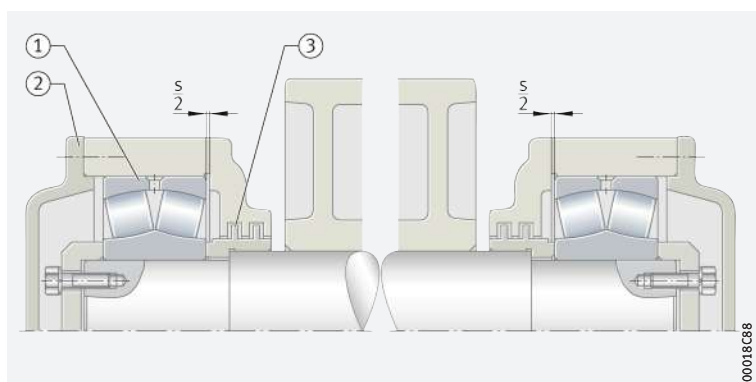

00018C88

8.8 Raceways with direct bearing arrangement

The raceways must be produced as a rolling bearing raceway

In rolling bearings without an inner ring, the rolling elements run directly on the shaft, while in bearings without an outer ring they run directly in the housing bore. The shaft and/or housing bore must therefore be produced as a rolling bearing raceway; steels, surface hardness and hardening depth \blacktriangleright 180.



The raceways must be free of waviness and precision machined (grinding and honing); for design of raceways see product chapter.

The fits have a major influence on the bearing clearance

The shaft and housing fits have a considerable influence on the bearing and operating clearance of the rolling bearing; this must be taken into consideration in determining the tolerances.

Steels for the raceways

Through hardening steels



Through hardening steels in accordance with ISO 683-17 (e.g. 100Cr6) are suitable as materials for rolling bearing raceways in direct bearing arrangements. These can also be surface layer hardened.

Case hardening steels



Case hardening steels must conform to DIN EN ISO 683-17 (e.g. 17MnCr5, 18CrNiMo7-6) or EN 10084 (e.g. 16MnCr5).

Steels for induction surface layer hardening



For flame and induction hardening, steels to DIN EN ISO 683-17 must be used (e.g. C56E2, 43CrMo4) or DIN 17212 (e.g. Cf53).

Surface hardness and hardening depth of raceways

Nominal surface hardness: ≥ 670 HV

The hardness values apply to raceways, axial washers and shaft shoulders. Steels hardened by means of case, flame or induction hardening must have a surface hardness of 670 HV to 840 HV and an adequate hardening depth CHD or SHD.

Determining CHD and SHD

The requisite case hardening depth CHD for case hardening steels is determined in accordance with \blacktriangleright 180 | f1 5, while the requisite surface hardening depth SHD for steels for induction surface layer hardening is determined in accordance with \blacktriangleright 181 | f1 6.

Nominal hardening depth $\geq 0,3$ mm

In accordance with DIN EN ISO 15787:2010, the hardening depth is the depth of the hardened surface zone at which there is still a hardness of 550 HV1. It is measured on the finish ground shaft and must correspond to the stated values, but must in any case be $\geq 0,3$ mm.

Determining the case hardening depth

Approximation value for case hardening depth

An approximation value for determining the minimum hardness depth can be found in \blacktriangleright 180 | f1 5. The reference value for the load present is the equivalent stress in accordance with the distortion energy hypothesis (DEH) as a function of the rolling element diameter D_w and the magnitude of the load.

f1 5
 Case hardening depth

$$CHD \geq 0,052 \cdot D_w$$

Legend

CHD	mm	Case hardening depth
D_w	mm	Rolling element diameter.

The local hardness must always be above the local requisite hardness, which can be calculated from the equivalent stress.



25

Case hardening depth and hardness profile

HV = hardness according to Vickers
 z = depth under the contact surface

- ① Requisite hardness (equivalent stress profile)
- ② Actual hardness profile

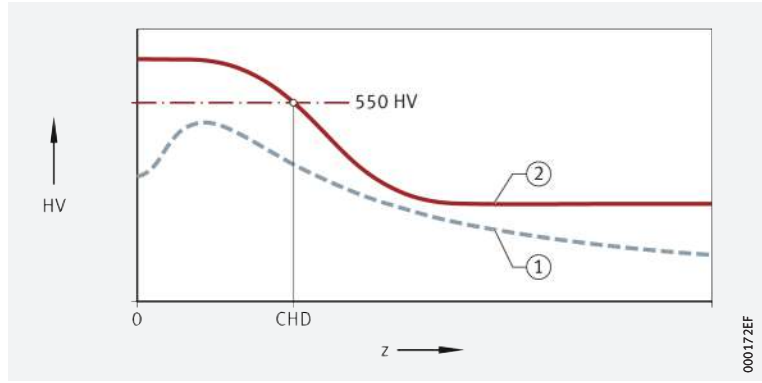

Determining the surface hardening depth

For the calculation of the surface hardening depth SHD >181| f16 applies.

f16

Surface hardening depth

$$SHD \geq 140 \cdot D_w / R_{p0,2}$$

Legend

SHD	mm	Surface hardening depth
D_w	mm	Rolling element diameter
$R_{p0,2}$	N/mm ²	Yield point of base material.

Raceway hardness less than 670 HV



If the raceway fulfils the requirements for rolling bearing materials but its hardness value is less than 670 HV (58 HRC), the static and dynamic load carrying capacity of the bearing will be reduced. In order to determine the load carrying capacity, the basic dynamic load rating C of the bearings must be multiplied by the reduction factor f_H and the basic static load rating C_{0r} by the reduction factor f_{H0} >181| 26 and >181| 27.

26

Dynamic hardness factor at reduced hardness of raceways

f_H = dynamic hardness factor
 HV, HRC = surface hardness

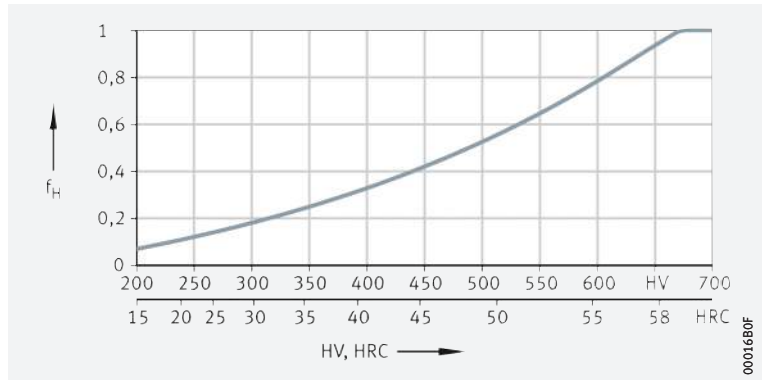

27

Static hardness factor at reduced hardness of raceways

f_{H0} = static hardness factor
 HV, HRC = surface hardness

- ① Roller
- ② Ball

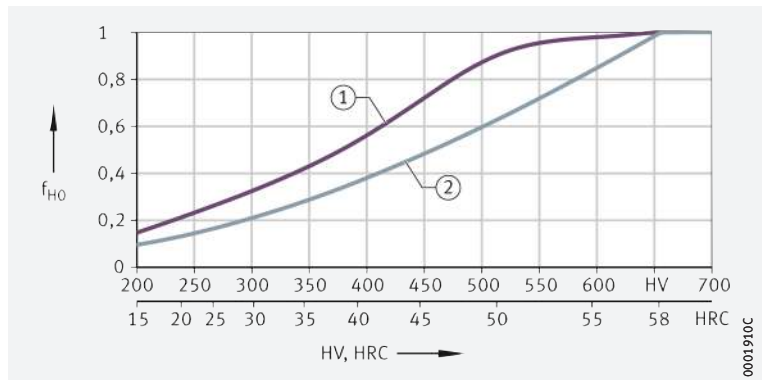

9 Sealing of bearing positions

Sealing has a decisive influence on the function and operating life of a bearing

In order to make optimum use of the potential life of a rolling bearing, the egress of lubricant (grease, oil) must be reliably prevented and the bearing must be securely protected against the ingress of solid and liquid contaminants (e.g. dust, sludge, water, cleaning liquid)
 ▶ 182 | 1.

1
 Principle of a sealing position

- ① Lubricant
- ② Seal
- ③ Contaminants

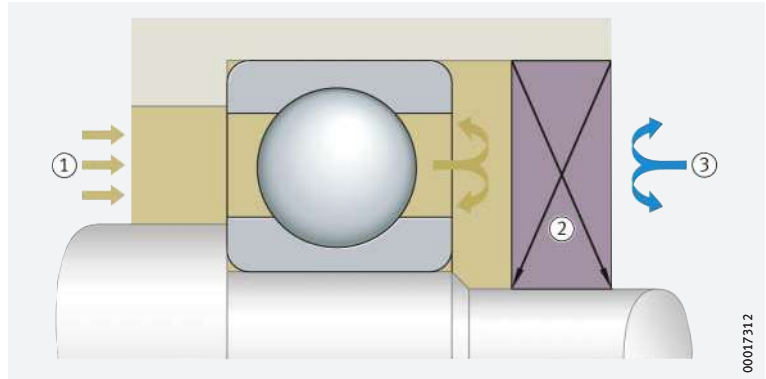

Contaminant particles can damage the bearing

If contaminant particles enter the bearing, overrolling of the particles at the rolling contact forms indentations that cause running noise and may constitute initial points for rapidly propagating material fatigue.

Contaminants with an abrasive action

Where contaminants that have an abrasive action are present in the bearing, the rolling contact surface partners undergo wear and there is a progressive increase in the bearing clearance. With an increasing operating duration, the running accuracy of the bearing in particular is reduced until it fails.

Liquid and vaporous media

If liquid or vaporous media enter the bearing, the lubrication conditions at the rolling contacts are disrupted. If corrosive media are present, oxidative damage of the surfaces will also occur. Both of these situations lead to a considerable reduction in the operating life of bearings.



Effective sealing of the bearing position is thus decisive for the long operating life of a rolling bearing.

Non-contact or contact seals

A basic distinction is made between contact and non-contact seals in the adjacent construction and the bearing.

9.1 Non-contact seals

Non-contact seals are free from friction

Non-contact seals are particularly suitable for applications with high speeds and high requirements for freedom from friction and low heat generation. They are free from friction, except for a small amount of lubricant friction in the sealing gap. In general, non-contact seals are free from wear and have an almost unlimited operating life.

Measures which prevent the ingress of liquids into the bearing while stationary

In order to prevent the ingress of liquids while stationary, additional sealing measures are necessary, such as the supply of barrier media. Where higher requirements for sealing integrity are present, a relatively large design envelope is required for labyrinth designs.



☞ *Stationary baffle plates prevent the egress of grease*

☞ *Compact solutions in the form of bearings with sealing shields integrated on one or both sides*

Grease sealing by means of baffle plates and sealing shields

In the case of grease-lubricated bearings, the egress of grease can be prevented in many cases on the stationary bearing ring by the use of simple baffle plates. Depending on the mounting and operating situation, the plates are braced on either their outer or inner edge ▶ 183 | ☐ 2. The grease collar that forms at the sealing gap gives protection against slight contamination impact from outside.

For designs in which there is no space adjacent to the bearing for a seal, there are rolling bearings with sealing shields integrated on both sides ▶ 183 | ☐ 2; see product chapter. These bearings are supplied with a grease charge. Bearings with only one sealing shield on one side are also commercially available.

☐ 2 Baffle plates and integrated sealing shields

- ① Baffle plate braced on outer edge
- ② Baffle plate braced on inner edge
- ③ Sealing shields integrated on both sides

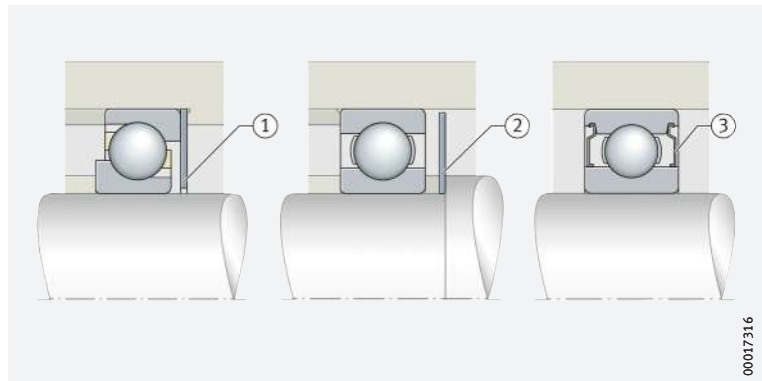

Gap seals

☞ *Narrow gap between shaft and housing*

☞ *Grooves in the housing increase the sealing action if grease lubrication is used*

☞ *Helical grooves are used for oil return*

A narrow gap between the shaft and housing is a simple and, in many cases, adequate means of sealing against the egress of grease and slight contamination impact from outside ▶ 183 | ☐ 3. The sealing gap can be held to a relatively narrow size.

If grease lubrication is used, the sealing action of the gap can be increased by several grooves in the through bore of the housing ▶ 183 | ☐ 3. The grooves act as storage chambers and hinder the ingress of contaminants as well as the egress of lubricant.

Where oil lubrication is used and the shaft is horizontal, the through bore in some housings has a helical groove ▶ 183 | ☐ 3. Depending on the spiral direction relative to the rotational direction of the shaft, oil creeping along the shaft is returned to the housing or contaminants are transported from the gap to the outside. A similar sealing action is achieved if the helical groove is located on the shaft.

☐ 3 Gap seals

- ① Gap seal
- ② Gap seal, grooves in the bore
- ③ Gap seal, helical grooves in the bore

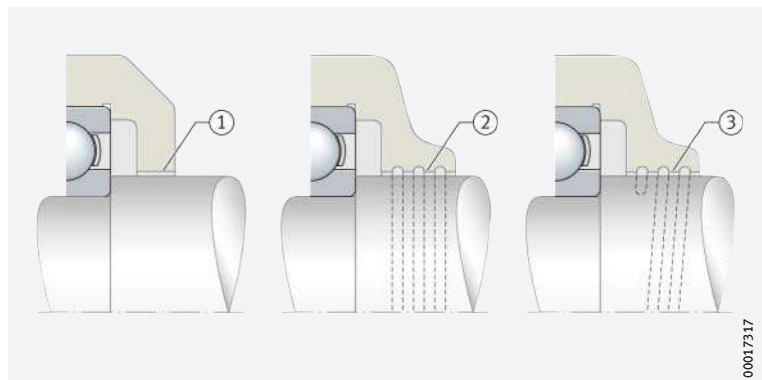

The sealing action is achieved by means of rotation and centrifugal force displacement

The sealing gap is protected by an outer flinger shield

Splash rings and flinger shields

In the case of splash rings and flinger shields, sealing action is achieved by means of rotation and centrifugal force displacement ▶ 184 | 4 and ▶ 184 | 5. Splash rings can give effective sealing, for example, where oil lubrication is used and the shaft is horizontal ▶ 184 | 4. The oil creeping along the bush is propelled away by the splash rings and flows back into the housing via a drain hole.

If heavy contamination impact or direct impact by liquids is expected at the sealing position, the sealing gap can be protected on the outside by means of a flinger shield ▶ 184 | 5. The same purpose is fulfilled by a simple rubber shield that – without additional means of location – is seated under tension on the shaft or shaft bush ▶ 184 | 5. At higher speeds, however, there is a risk that the rubber shield will become detached from the shaft under the influence of centrifugal force. For this reason, vulcanised flinger shields with sheet metal reinforcement are available that are used very effectively in, for example, passenger car wheel bearing units of the 1st Generation or shaft support bearings ▶ 184 | 5.

4 Splash rings

- ① Splash rings
- ② Housing with collector groove and drain hole

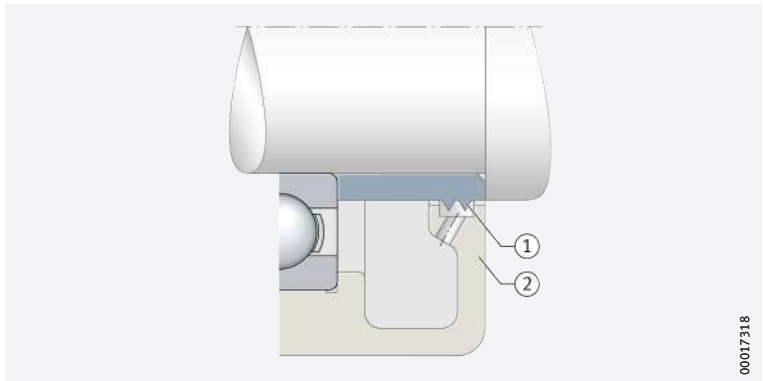

00017318

5 Flinger shields

- ① Sheet metal shield as flinger shield
- ② Simple rubber shield as flinger shield
- ③ Flinger shield with sheet metal reinforcement in bearing unit with sealing washer

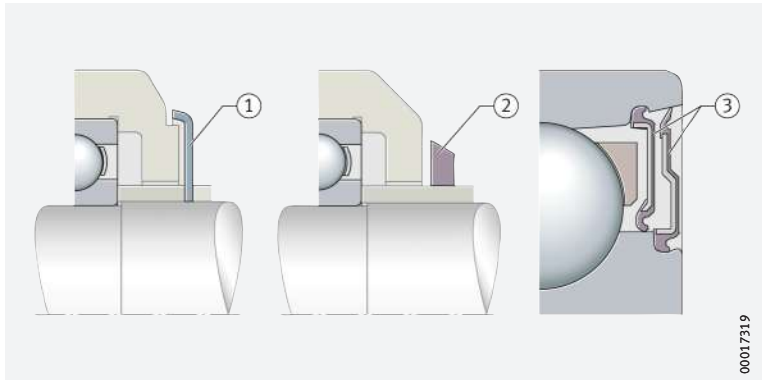

00017319

Labyrinth seals

Protective or collector labyrinths provide very good sealing results

Protective labyrinths

Collector labyrinths

A considerably greater sealing action than with gap seals is achieved by labyrinths incorporating gaps filled with grease. A distinction is made between protective labyrinths and collector labyrinths.

Protective labyrinths are centrifugal force seals. They protect sealing positions subjected to little external load due to liquids against the egress of grease and the ingress of contamination.

Collector labyrinths are labyrinths of highly complex design with collector grooves and drain holes in the housing that are also suitable for the sealing of sealing positions subjected to very high impact by liquids.



☞ *Labyrinths are configured with radially or axially aligned crosspieces*

Depending on the contamination load, labyrinths are configured with one crosspiece or several crosspieces ▶ 185 | 6. Labyrinths with several radially aligned crosspieces are only considered, for reasons of mounting, for split housings ▶ 185 | 6. Their advantage is that the grease propelled outwards is held in U-shaped housing slots, which thus improves the sealing action.

☞ *In order to improve sealing, labyrinths are frequently filled with grease*

In practice, labyrinths filled with grease are frequently used in order to achieve better sealing against contamination. In a highly contaminated environment, fresh grease is occasionally pressed into the sealing gap, which has the effect of pressing contaminated grease out of the sealing position.



If significant angular deviations of the shaft are expected in the case of spherical roller bearings, for example, there is a risk that grazing of the crosspieces will occur in labyrinths in accordance with ▶ 185 | 6. In this case, labyrinths with bevelled crosspieces are used. The bevel is matched to the motion about the centre point of the bearing ▶ 185 | 6.



Examples of labyrinth seals

- ① Labyrinth with axially aligned crosspieces
- ② Labyrinth with radially aligned crosspieces
- ③ Labyrinth with bevelled crosspieces
- ④ Taper type lubrication nipple to DIN 71512-A with integrated protective labyrinth

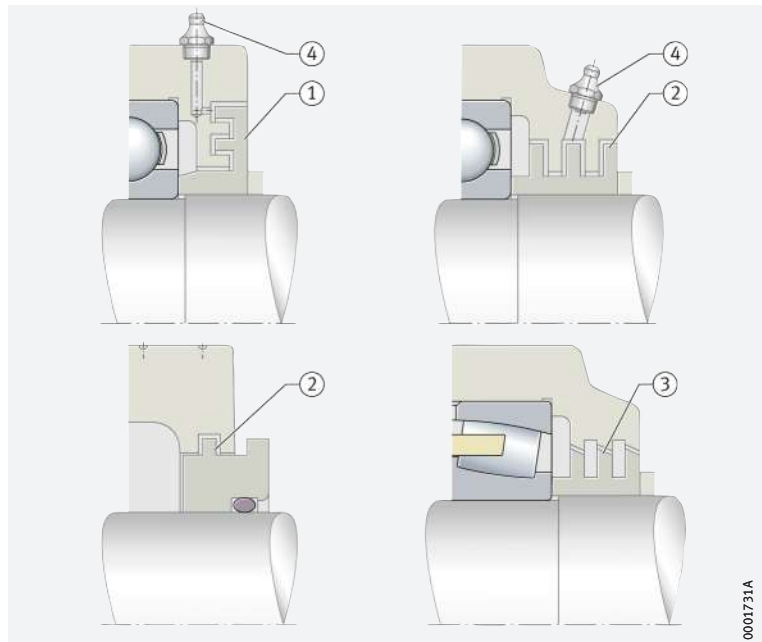

Labyrinth seals integrated in the bearing

- ① Bearing with integrated protective labyrinth
- ② Bearing with rubberised sealing shield as protective labyrinth

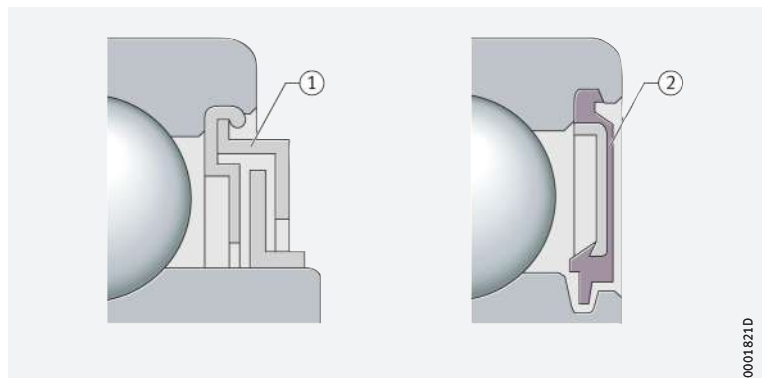

☞ *Collector labyrinths*

Where there is heavy liquid impact and sealing positions are inundated by surge flows, so-called collector labyrinths are used. These seals effectively repel liquids if the sealing position is not subjected to prolonged inundation while stationary.

9.2 Contact seals

☞ *The contact pressure at sliding contact causes friction in contact seals at the sliding surface*

☞ *Felt rings are simple sealing elements used with grease lubrication*

Contact seals are in contact at their sliding surface under a certain contact pressure. In many cases, they represent the most favourable solution in terms of design envelope and costs. The general disadvantage, however, is the loss of energy due to friction at the sealing contact.

Felt ring seals

Felt rings are simple sealing elements that have proved effective primarily with grease lubrication ► 186 | 8. After a short running-in time, the felt forms a sealing surface in preload-free contact with excellent sealing action against dust. Before mounting, the rings are soaked with oil.



Felt ring seals

① Felt rings, arranged individually or adjacent to each other

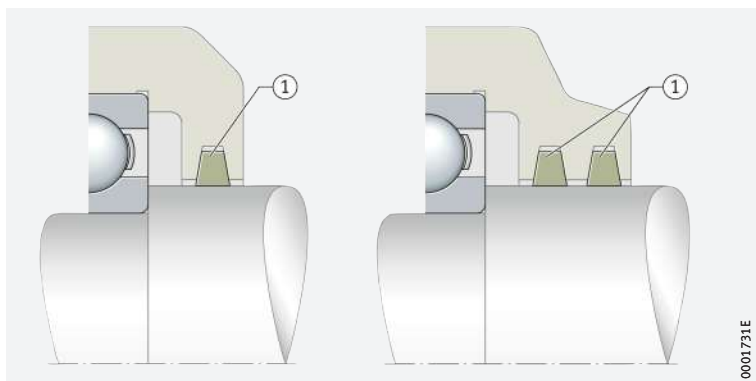

☞ *Several felt rings can also be arranged adjacent to each other*

A felt ring is sufficient if the level of contamination is not too high. If the environmental conditions are less favourable, several felt rings can be arranged adjacent to each other.

Operating temperatures up to +100 °C are possible. At higher temperatures, sealing rings made from wound yarns are required that comprise PTFE, graphite or aramide and glass fibres, and are impregnated with PTFE or graphite.



The dimensions of felt rings and annular slots are standardised and stated in DIN 5419.

☞ *Sealing washers made from thin sheet metal provide good sealing for grease lubrication*

☞ *Metallic sealing washers are suitable if no static or pressure-resistant sealing is required*

☞ *In washers in double arrangements, the intermediate space is filled with grease*

Metallic sealing washers

When using grease lubrication, effective sealing can also be achieved by axially sprung metallic sealing washers ► 187 | 9. These thin sheet metal seals are braced in the end face of the inner ring or outer ring and are in spring contact with the other bearing ring. In order to prevent fretting of the seal tongues during running-in, these washers are greased before mounting.

At the sealing contact, the sprung sealing washer beds into the bearing ring during the running-in process and the preload decreases. A groove is formed in the bearing ring that, together with the seal edge, forms a small "microlabyrinth" under light contact. Due to this principle, these seals are suitable for bearing positions that require no static or pressure-resistant sealing of the bearing.

In addition to simple sprung sealing washers, there are also washers in double arrangements. The intermediate space is additionally filled with grease at the mounting stage. Due to their small section width, these seals can normally be fitted retrospectively and without design modifications to the adjacent construction.



Metal sealing washers

- ① Sealing washers braced on inner ring
- ② Sealing washers braced on outer ring
- ③ Sealing washers in double arrangement

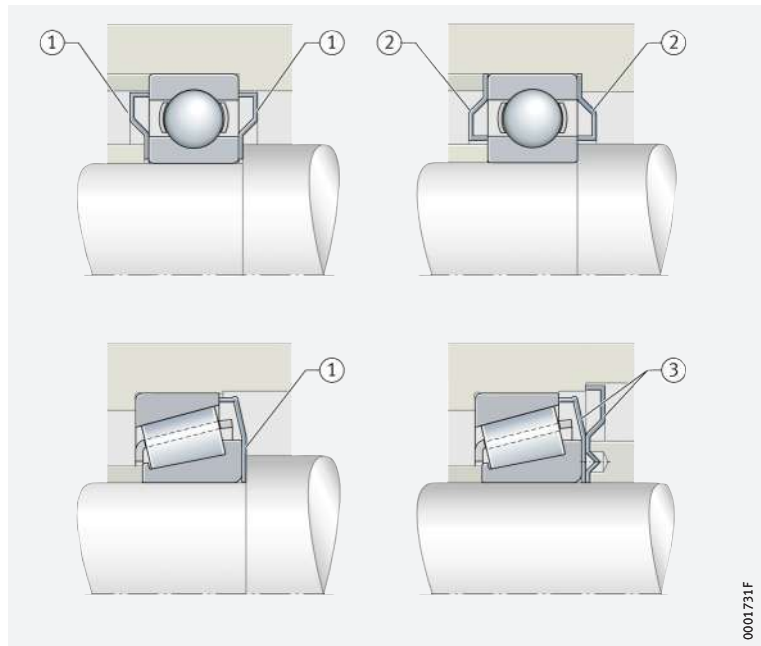

0001731F

Sealing washers with elastomer seal lip

 Sealing washers integrated in the bearing are used for small design envelopes

 Various elastomers are available for selection

 The seal lip can be in radial or axial contact

 Sealing washer RSD with radial sealing action

 Sealing washer RSR with radial contact

 Sealing washer for axial inward sealing

Where the design envelope is small, rolling bearings (e.g. ball bearings, roller bearings, spherical roller bearings, toroidal roller bearings) with integrated sealing washers are frequently used; see product chapter. These sealing washers comprise a sheet metal washer for reinforcement and have a vulcanised elastomer seal lip.

Various elastomers can be selected in accordance with the chemical and thermal requirements. In general, nitrile butadiene rubbers NBR are used. For applications with higher temperatures or speeds, sealing washers with lips made from fluoroelastomers FKM are frequently used.

Sealing washers are available with seal lips for radial or axial contact ►188|  10. They are suitable for sealing against loss of grease and ingress of contamination at low pressure differentials.

Sealing washers with one or more radial seal lips are also suitable for the sealing of rolling bearings with axial relative motion between the inner ring and outer ring (e.g. in spherical roller bearings or toroidal roller bearings).

Sealing washers with seal lips in axial running contact are used primarily in bearings with lower axial operating clearance (e.g. in deep groove ball bearings).

Sealing washers RSD have a seal lip with radial sealing action and are characterised by low seal friction ►188|  10. The seal lip is initially in very light contact with the shaft (little or no contact pressure). After running-in, a minimal sealing gap is created.

Seals RSR with radial contact are equipped with a seal lip geometry that is similar to a rotary shaft seal ►188|  10. The angles of the seal edge are selected such that the pumping action at the sealing contact repels liquids outwards and a small amount of grease is conveyed under the seal edge in order to lubricate the seal lip.

In the case of sealing washers for axial sealing, an additional outer seal lip is often provided ►188|  10. The outer seal lip (protective lip) is of a non-contact design and, together with the undercut on the inner ring, forms an additional protective labyrinth against the ingress of contamination.

Sealing washer for axial outward sealing

A seal geometry that is designed in particular for applications with a rotating outer ring and high requirements for retention of the grease is the sealing washer with a seal lip in axial contact in accordance with **►188** | **10**. This seal has increased sealing action against the egress of grease. An additional non-contact lip that repels the grease provides a grease chamber in front of the main seal lip for axial outward sealing.

10
Sealing washers with elastomer seal lips

- ① Sealing washer RSD
- ② Sealing washer RSR
- ③ Sealing washer for axial inward sealing with additional external seal lip
- ④ Sealing washer for axial outward sealing

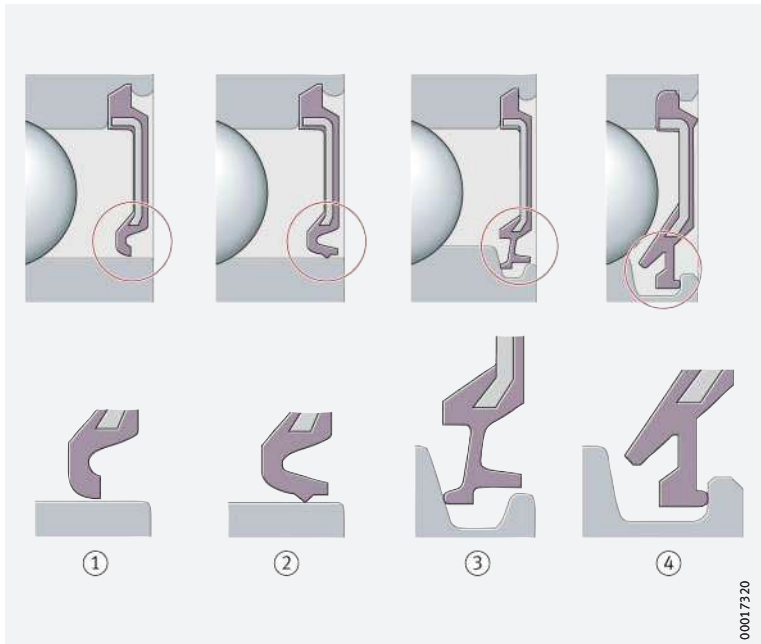

Lip seals

Lip seals provide radial or axial sealing

Lip seals are seals with one or more seal lips that give axial or radial sealing. These seals are predominantly elastomer seals. Typical designs are shown in **►188** | **11** to **►189** | **13**.

Double lip seal: the inner seal lip prevents egress of lubricant, the outer seal lip prevents ingress of contamination

►188 | **11** shows a double lip seal made from NBR for use in standard plummer block housings. The radially split seal can be easily inserted in the annular slot in the housing. Ingress of contamination is prevented by the outer seal lip, while the inner seal lip prevents the egress of lubricant. The grease between the two seal lips supports the sealing action.

11
Double lip seal for plummer block housings

- ① Radially split double lip seal

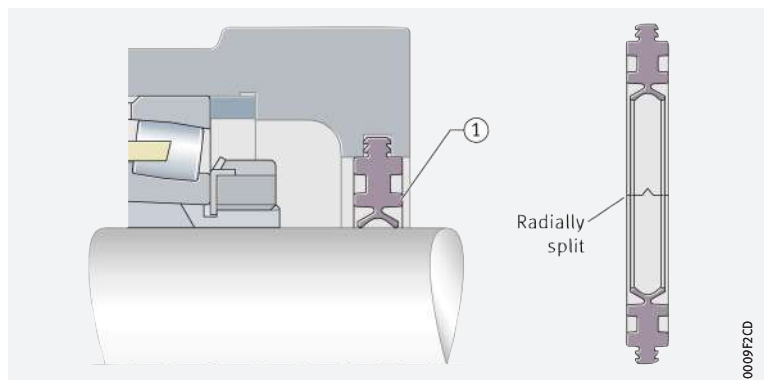



V-ring seals are lip seals with axial sealing action

The V-ring is a lip seal with axial sealing action ► 189 | 12. The ring is made from elastic rubber NBR. During mounting, it is stretched and slid onto the shaft so that the seal lip is in contact with the housing wall.



At circumferential velocities over 12 m/s, experience shows that the V-ring must be radially located so that it does not become detached due to centrifugal force. Precise circumferential velocities for specific applications must always be agreed in consultation with the sealing ring manufacturer.

12 V-ring seal

- ① V-ring seal as protective seal
- ② V-ring for grease sealing in labyrinth

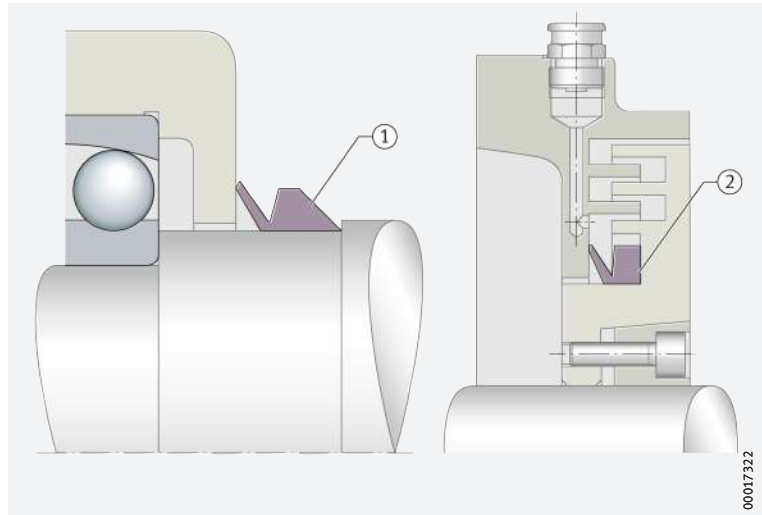

00017322

Lip seals of three-part construction

Lip seals of a three-part construction with single or multiple lips (comprising an NBR sealing element between two sheet steel washers) are used, for example, in radial insert ball bearings ► 189 | 13.

The outer sheet steel washer protects the seal lips against damage

During mounting, this sandwich construction allows concentric alignment of the rubber seal lip with the inner ring. The outer washer protects the seal lips effectively against damage caused by coarse contaminants.

13

Lip seals of sandwich construction with seal lip protection

- ① Axially preloaded seal lip
- ② Radially preloaded seal lip
- ③ Three radially preloaded seal lips

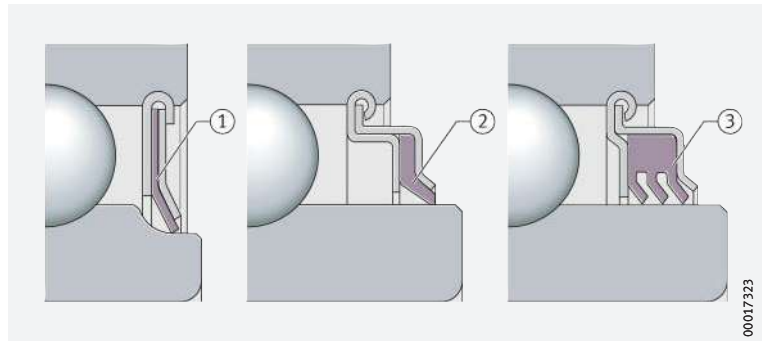

00017323

Rotary shaft seals



For oil sealing of rotating shafts, rotary shaft seals (RWDR) in accordance with DIN 3760 and DIN 3761 and with spring preload are suitable. Frequently used designs are shown in ► 190 | 14. The sealing rings are designed for applications with slight pressure differentials.

Speed limits for rotary shaft seals are given in DIN 3760.

With oil lubrication

Depending on the seal material and the surface structure of the shaft, the geometry of the seal lips generates a pumping action in the sealing gap towards the steep flank of the seal lip. The sealing ring is therefore mounted with the steep flank facing in the direction of the medium against which sealing is required.

With grease lubrication

In the case of grease lubrication, the steep flank of the RWDR is often placed in the direction of grease egress. As a result, some grease passes under the seal lip for lubrication of the sealing edge. The preload force of seal lips – in relation to their contact length – is normally 80 N/m to 150 N/m.

14

Rotary shaft seals

- ① Type A
- ② Type AS
- ③ Type B
- ④ Type C
- ⑤ Type D

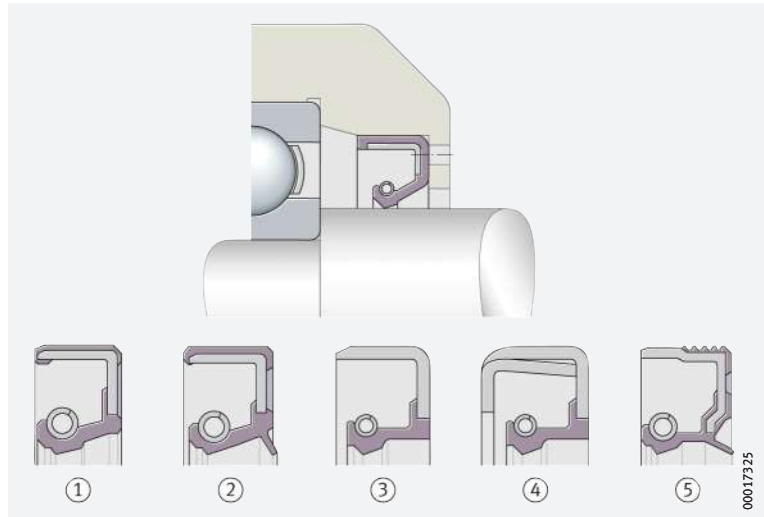

Schaeffler sealing rings are highly suitable for a small radial design envelope and in combination with needle roller bearings

Springless Schaeffler sealing rings G, GR, SD

Low-friction sealing of bearing positions with a small radial design envelope, such as bearing positions with needle roller bearings, can be effectively achieved using sealing rings G, GR and SD; see product chapter. These sealing rings can be used individually or in a double arrangement ▶ 190 | 15. In the double arrangement, one seal lip faces inwards to seal the lubrication medium, while the second seal lip faces outwards to give protection against contamination. In order to improve the protective function, the space between the seals can be filled with grease. With an extended inner ring, a sealing ring with the same outside diameter as the outer ring can be used, where the seal lip runs on the extended inner ring. Sealing rings give good protection against contamination and spray water as well as against the egress of oil and grease under slight pressure differentials. In order to reduce friction and protect the seal lip against damage, the sealing edge must be lubricated.

15

Schaeffler sealing rings

- ① Single arrangement, bearing with extended inner ring
- ② Double arrangement, bearing with inner ring
- ③ G sealing ring
- ④ GR sealing ring
- ⑤ SD sealing ring

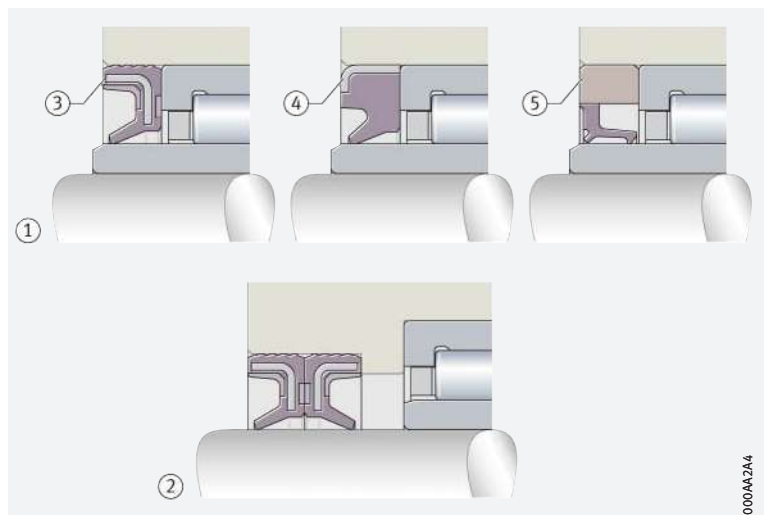



10 Mounting and dismounting

10.1 Handling

Rolling bearings, rolling bearing parts and Arcanol rolling bearing greases are high quality goods and must therefore be handled with care.

Storage of rolling bearings

The performance capability of modern rolling bearings lies at the boundaries of what is technically achievable. The materials, dimensional and running tolerances, surface quality and lubrication have been optimised for maximum levels of function, which means that even slight deviations in functional areas, such as those caused by corrosion, can impair the performance capacity. In order to realise the full performance capability of rolling bearings, it is essential to match the corrosion protection, packaging, storage and handling to each other.

Corrosion protection and packaging constitute part of the bearing and are optimised such that they preserve all characteristics of the product at the same time as far as possible. In addition to protecting the surface against corrosion, this includes emergency running lubrication, friction, lubricant compatibility, noise behaviour, resistance to ageing and compatibility with rolling bearing components (cage and seal material).

Storage conditions for rolling bearings



As a basic prerequisite, parts must be stored in a closed storage area which cannot be affected by any aggressive media, such as exhaust gases from vehicles or gases, mist or aerosols of acids, lyes or salts. Direct sunlight should be avoided since, apart from the harmful effects of UV radiation, it can lead to wide temperature fluctuations in the packaging. The temperature should be constant and air humidity should be as low as possible. Extreme shifts in temperature and increased humidity lead to condensation.

Conditions for storing rolling bearings

The following conditions must be fulfilled:

- frost-free storage, i. e. a temperature of $> +5\text{ °C}$
 (this prevents formation of white frost, a maximum of $+2\text{ °C}$ is permissible for up to 12 hours per day)
- maximum temperature $+40\text{ °C}$
 (to prevent excessive drainage of anti-corrosion oils)
- relative humidity $\leq 65\%$
 (with temperature changes, up to 70% permissible for up to 12 hours per day).



The temperature and humidity must be continuously monitored. This can be carried out using a datalogger. The measurements must be taken at intervals of no more than 2 hours. At least 2 measurement points must be selected: the highest point and the lowest point in the vicinity of an external wall at which the goods can be stored.

Storage periods for rolling bearings

Rolling bearings should not be stored for longer than 3 years. This applies both to open and to greased bearings with sealing shields or washers. In particular, specifically greased bearings should not be stored for too long, since the chemical-physical behaviour of greases may change during storage. Even if the minimum performance capacity remains, the safety reserves of the grease may have diminished.

Even slight deviations in functional areas will impair the performance capability of the bearings

Corrosion protection and packaging constitute part of the bearing

Maximum storage period of 3 years

☞ Check the bearings at the end of the storage period

In general, rolling bearings can be used even after their permissible storage period has been exceeded, if the storage conditions during storage and transport were observed. If the conditions are not fulfilled, shorter storage periods must be anticipated. If the periods are exceeded, it is recommended that the bearing be checked for corrosion, as well as for the condition of the anti-corrosion oil and the condition of the grease, before it is used. The aforementioned storage periods are empirical values based purely on practice and do not constitute an extension to the legal or, where applicable, contractually agreed warranty period.

Storage of Arcanol rolling bearing greases

The information on storage of rolling bearings applies as appropriate to Arcanol rolling bearing greases. The precondition is that the grease is stored in closed, completely filled original containers.

Storage periods for Arcanol rolling bearing greases

☞ Rolling bearing greases do not have unlimited stability

Rolling bearing greases are mixtures of oil, thickener and additives. Such mixtures of liquid and solid substances do not have unlimited stability. During storage, their chemical-physical characteristics may change and they should therefore be used up as soon as possible.

☞ The storage period for Arcanol greases is 3 years

If the storage conditions are observed, Arcanol greases can be stored without loss of performance for 3 years. As in the case of rolling bearings, however, the permissible storage period should not be seen as a rigid limit. If storage is carried out as prescribed, most greases can also be used after 3 years, if allowances are made for small changes. If there is any doubt when using older greases, random sample checking of chemical-physical characteristics is recommended in order to determine any changes in the grease. It is therefore not possible to state storage periods for containers that have been opened. If containers are to be stored after opening, the grease surface should always be brushed flat, the container should be sealed airtight and it should be stored such that the empty space is upwards. High temperatures should be avoided in all cases. The aforementioned storage periods are empirical values based purely on practice and do not constitute an extension to the legal or, where applicable, contractually agreed warranty period.

Unpacking of rolling bearings

☞ Observe guidelines on unpacking

Perspiration leads to corrosion. Hands should be kept clean and dry and protective gloves worn if necessary. Bearings should only be removed from their original packaging immediately before assembly. If bearings are removed from multi-item packaging with dry preservation, the package must be closed again immediately, since the protective vapour phase is only effective in closed packaging. Bearings should be oiled or greased immediately after unpacking.

Compatibility, miscibility

☞ Observe guidelines on compatibility and miscibility

The anti-corrosion agents in bearings with an oil-based preservative are compatible and miscible with oils and greases having a mineral oil base. Compatibility should be checked if synthetic lubricants or thickeners other than lithium or lithium complex soaps are used. If there is an incompatibility, the anti-corrosion oil should be washed out before greasing, especially in the case of lubricants with a PTFE/alkoxyfluoroether base and thickeners based on polycarbamide. Bearings should be washed out if the lubricant is changed or the bearings are contaminated.



 *Suitable agents for degreasing and washing*

Cleaning of rolling bearings

The following are suitable for degreasing and washing of rolling bearings:

- aqueous neutral, acidic or alkaline cleaning agents.
Check the compatibility of alkaline agents with aluminium components before cleaning
- organic cleaning agents such as paraffin oil free from water and acid, petroleum ether (not petrol), spirit, dewatering fluids, freon 12 substitutes, cleaning agents containing chlorinated hydrocarbons.



Cleaning should be carried out using brushes, paint brushes or lint-free cloths. In the case of resinous oil or grease residues, precleaning by mechanical means followed by treatment with an aqueous, strongly alkaline cleaning agent is recommended. Legal regulations relating to handling, environmental protection and health and safety at work must be observed. The specifications of cleaning agent manufacturers must be observed. Paraffin oil, petroleum ether, spirit and dewatering fluids are flammable, while alkaline agents are corrosive. The use of chlorinated hydrocarbons is associated with the risk of fire, explosion and decomposition as well as with health hazards. These hazards and appropriate protective measures are described comprehensively in Datasheet ZH1/425 of the Hauptverband der gewerblichen Berufsgenossenschaften (German Federation of Institutions for Statutory Accident Insurance and Prevention). Rolling bearings must be dried and preservative applied immediately after cleaning.

10.2 Guidelines for mounting



Comprehensive information on mounting and dismounting is given in the publications Mounting Handbook MH 1 and IS 1, Mounting and Maintenance of Rolling Bearings.

 *Observe guidelines*

The following guidelines must always be taken into account:

- The assembly area must be kept clean and free from dust
- Protect bearings from dust, contaminants and moisture.
Contaminants have a detrimental influence on the running and operating life of rolling bearings
- Before mounting work is started, familiarise yourself with the design by means of the final assembly drawing
- Before mounting, check whether the bearing presented for mounting corresponds to the data in the drawing
- Check the housing bore and shaft seat for dimensional, geometrical and positional accuracy and for cleanliness
- Check that the shaft and housing bore have a lead chamfer of 10° to 15°
- Wipe away any anti-corrosion agent from the seating and contact surfaces, wash anti-corrosion agent out of tapered bores
- Lightly oil the bearing ring seating surfaces or rub with solid lubricant
- Do not cool the bearings excessively. Moisture due to condensation can lead to corrosion in the bearings and bearing seats
- After mounting, provide the rolling bearings with lubricant
- Check the correct functioning of the bearing arrangement.

10.3 Accessories for mounting



Avoid applying direct blows to the bearing rings with a hammer.

Mounting of non-separable bearings

In the mounting of non-separable bearings, the mounting forces must always be applied to the ring with a tight fit ► 194 | 1. This ring is also mounted first. Forces acting on the ring with a loose fit are transmitted by the rolling elements. This can damage the raceways and rolling elements.



Non-separable bearing

Tight fit of the inner ring, mount this ring first

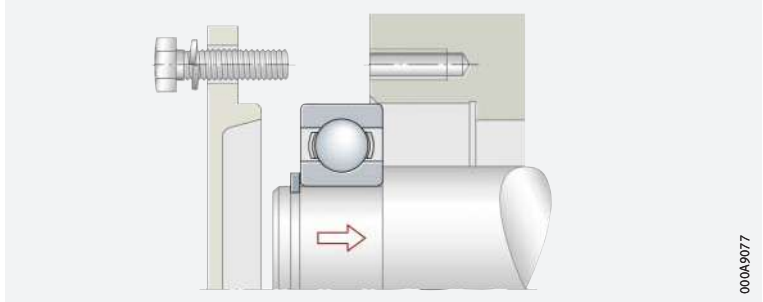

Mounting of separable bearings

Mounting is easier in the case of separable bearings; the two rings can be mounted individually ► 194 | 2. Rotating the ring while fitting to give a screwdriver effect will help to avoid scraping marks.



Separable bearing

Tight fit of the inner ring, individual fitting of rings

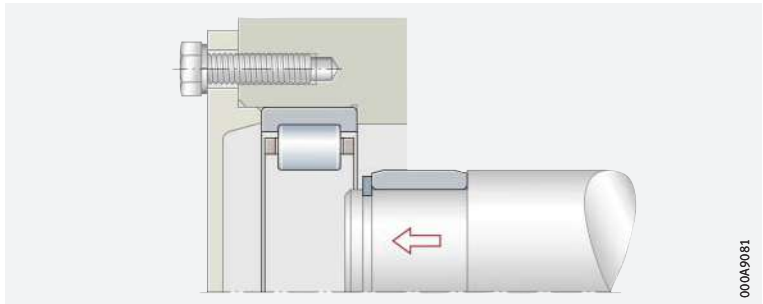

The mounting method is dependent on the bearing type and size

Mechanical, hydraulic and thermal accessories

Due to the different bearing types and sizes, rolling bearings cannot all be mounted and dismantled using the same method. An overview of suitable tools and methods for mounting and dismantling is shown in ► 206 | 1.

Cold fitting/driving on of bearings

Mechanical or hydraulic mounting

Where smaller bearings with cylindrical seats must have a tight fit on their mating parts and the interference values are not too large, they can be pressed onto the shaft or into the housing. Mechanical or hydraulic presses can be used for this purpose ► 194 | 3.



Hydraulic press for mounting

Direct pressing-in forces through the inner ring

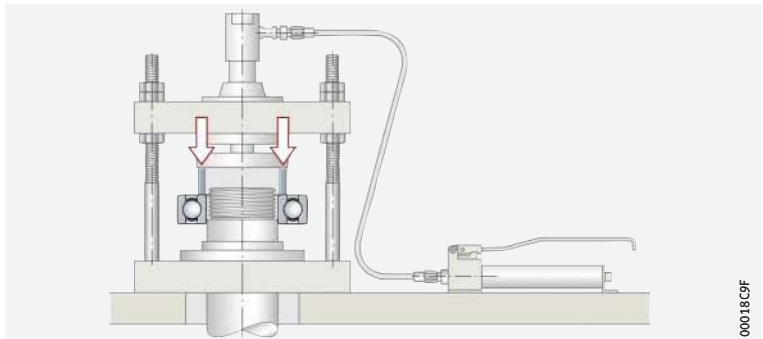



Mounting of small bearings

Small bearings can be driven onto the shaft using a mounting sleeve made from aluminium with a flat end face ▶195| 4. The mounting sleeve must be matched to the bearing ring to be mounted. During mounting, it must be ensured that no other bearing components, such as seals, are damaged.

4

Sleeve for driving up small bearings

① Aluminium mounting sleeve

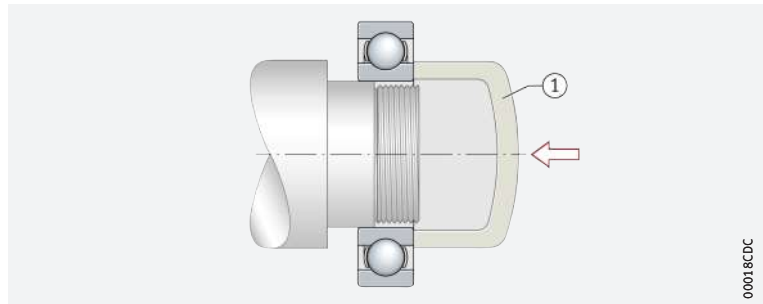

00018CDC

Thermal methods

Sliding on of warm bearings

Larger bearings, or bearings that must have a large interference fit, are generally mounted by means of thermal methods.

For the interference values normally used with rolling bearing seats, it is sufficient to heat the bearings to approx. +80 °C, with a maximum of +100 °C ▶195| 5.

Induction heating technology and electric ovens

Heating can be carried out using induction heating technology ▶204| 25. A distinction is made here between the low frequency technique (50 Hz to 60 Hz) and medium frequency technique (10 kHz to 25 kHz).

Induction heating devices

The induction heating devices described in ▶201|10.6 can be used to heat rolling bearings quickly, safely and, above all, cleanly to the correct temperature for mounting ▶203| 23 to ▶204| 25. The temperature is measured directly on the inner ring. Since the inner ring heats up more quickly than the outer ring, the bearing can be positioned on the shaft and in the housing at the same time with only slight heating of the outer ring.

Electric ovens, oil bath, heating plate

Furthermore, an electric oven, a clean oil bath or a thermostatically controlled heating plate, ▶195| 5, can be used. In the case of electric ovens and induction heating devices, the temperature is controlled by means of a temperature sensor or thermostat and is therefore held to very high accuracy. This is important since the hardness of the rings must not decrease due to the tempering effect.



When bearings are heated on a heating plate, all parts of the bearing must be protected against overheating (e.g. plastic parts, seals, lubricant) ▶195| 5.

5

Bearings with plastic cage: heating on a heating plate

① For standard bearings

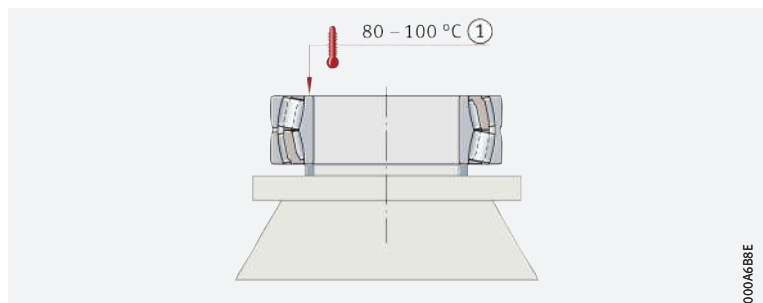

000AGBBE

In order to give a tight fit, the inner ring is pressed on axially

Mounting on tapered bearing seats

In the case of tapered seats, the tight fit required is achieved by pressing the inner ring on axially. Whether a sufficiently tight fit is achieved can be determined from the expansion of the inner ring and therefore the reduction in the radial internal clearance, or from the axial drive-up distance on the taper; see corresponding product chapters.

Checking of the clearance is necessary during mounting

Reduction in radial internal clearance

The reduction in radial internal clearance is the difference between the radial internal clearance before mounting and the bearing clearance after mounting of the bearing. The radial internal clearance must be measured first. During pressing on, the radial clearance (bearing clearance) must be checked until the necessary reduction in the radial internal clearance and thus the required tight fit is achieved.

Measuring the radial internal clearance of spherical roller bearings using a feeler gauge

The radial clearance of larger bearings is measured using a feeler gauge. In the case of spherical roller bearings, it must be ensured that both rows of rollers are measured at the same time ▶ 196 | 6.

It can only be ensured that the inner ring is not laterally offset relative to the outer ring when the internal clearance values are identical for both rows of rollers.



Radial internal clearance in spherical roller bearings

s_r = radial internal clearance

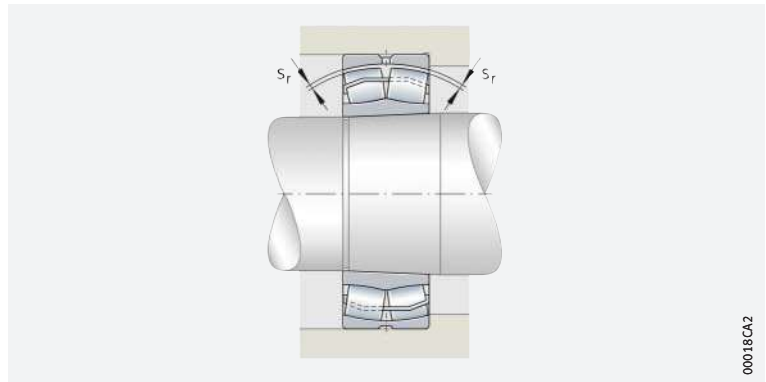

00018CA2

Measuring axial drive-up distance as an alternative to measuring radial internal clearance

Measuring the axial drive-up distance

Instead of reducing the radial internal clearance, the axial drive-up distance on the taper can be measured; see corresponding product chapters. For a shaft seat with a normal taper 1:12, the axial drive-up distance is approx. 15 times the reduction in radial internal clearance.

The mounting of small bearings with a tapered bore requires particular care. Since the radial internal clearance is often smaller than the thinnest measuring sheet, measurement using a feeler gauge is no longer possible. The bearing is therefore slid on, where possible, outside the housing. It may only be pressed on so far that the outer ring can still be rotated easily and, in the case of self-aligning bearings, can be swivelled out by hand under slight resistance. The shaft with the mounted bearing is inserted in the housing.

With large ring cross-sections, high forces are necessary for pressing-in

Mounting of withdrawal sleeves

Withdrawal sleeves are pressed on and secured between the inner ring and shaft by means of a nut seated on the shaft. For bearings with large ring cross-sections, considerable forces are necessary for pressing-in. In such cases, mounting is made easier by means of the nut with pressure screws shown in ▶ 197 | 7.



Pressure screws must always be tightened in a crosswise sequence

In order that the withdrawal sleeve is not pressed in skewed, the nut is first tightened so far that the pressure ring is fully in contact with the withdrawal sleeve. The pressure screws distributed uniformly around the circumference are then tightened uniformly in a crosswise sequence until the required reduction in radial internal clearance is achieved. Since the taper of the withdrawal sleeve is self-locking, the nut can then be removed; the position of the withdrawal sleeve is secured by the shaft nut.

7
Nut with pressure ring for pressing in large withdrawal sleeves, bearing with tapered bore

- ① Pressure screw
- ② Shaft nut
- ③ Pressure ring
- ④ Withdrawal sleeve

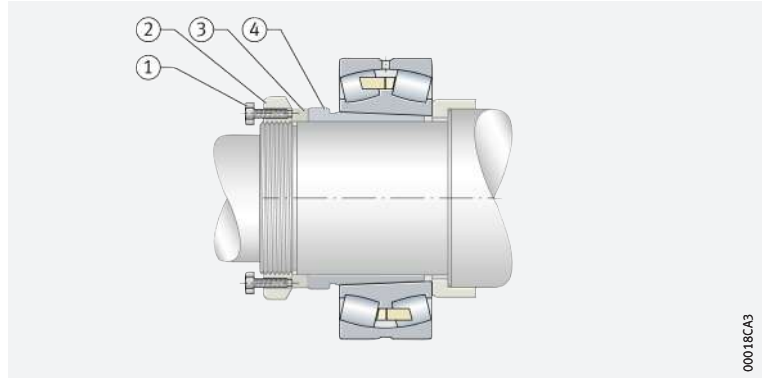

00018CA3



In the mounting of bearings with a tapered bore, it must be ensured that the seats of the sleeve connections are rubbed with a very thin layer of oil. Mounting pastes must not be used. While a thicker layer of lubricant would reduce the friction and thus allow easier mounting, the sleeves could however become loose when the nut with the pressure screws is removed after mounting. In operation, the lubricant would be gradually squeezed out of the fit joint and the tight fit of the bearing would be progressively lost.

Measures to be taken if the bearing is to be mounted again after dismounting

If the rolling bearing has been dismounted and is to be used again, it is not sufficient to move the retaining nut to its earlier position. After longer periods of operation, the fit loosens again since the thread undergoes settling and the surfaces become smoothed. In this case also, the reduction in radial internal clearance or the axial drive-up distance, or the expansion of the raceways in the case of cylindrical roller bearings, must be measured again.

Hydraulic nuts are available for all common sleeves and shaft threads

Mounting of large bearings using hydraulic nuts

For the mounting of large bearings, it is advisable to use a hydraulic nut in order to slide the bearing into place or press in the sleeve ► 197 | **8**. Hydraulic nuts are available for all common sleeves and shaft threads. The hydraulic method described not only gives easier mounting, but in particular easier dismounting.

8
Hydraulic nut for mounting of bearings with tapered bore

- ① Hydraulic nut

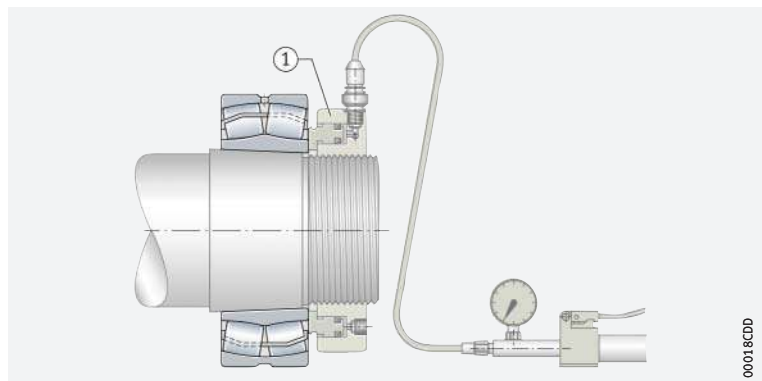

00018CDD

10.4 Regulating the clearance during mounting

The preset internal clearance gives the required bearing clearance after mounting

In some bearing arrangements, a certain radial and axial clearance necessitated by the design and temperature conditions is set during mounting which may also, if required, be zero clearance or light preload. In large volume situations, bearing units are increasingly fitted whose internal clearance has been preset such that the required bearing clearance is achieved when mounted; see product chapter and ►  MH 1.

10.5 Accessories for dismantling

Dismounting of bearings with a tight fit is more difficult

The removal of a rolling bearing mounted with a tight fit is not always easy, especially if fretting corrosion has formed. Defective rolling bearings can be dismantled by cutting or splitting of the rings.





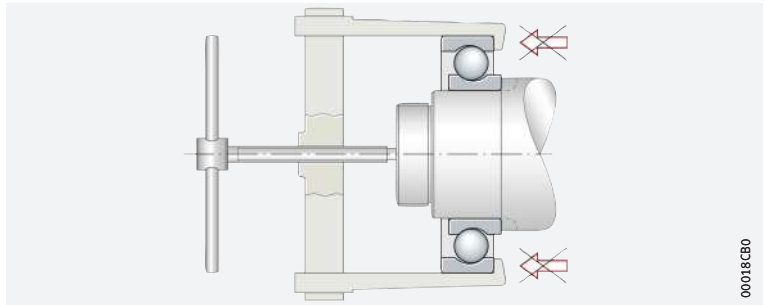

If the bearings are to be reused, the force used in pressing the bearing off must always be applied to the bearing ring with a tight fit ► 198 |  9.

 9
Incorrect dismantling: the rolling elements must support withdrawal forces



Dismounting of non-separable bearings: the tool must be applied to the ring with a tight fit

In the case of non-separable bearings, the ring fitted with a sliding seat must first be removed from its seat ► 198 |  10. The ring with a tight fit is then pressed off. The tools must be applied to the bearing ring with a tight fit ► 198 |  11 and ► 199 |  12. In order to apply the withdrawal device to the inner ring, extraction slots are provided in the shaft shoulder ► 199 |  12.

Simpler dismantling with fixed press

Dismounting of rolling bearings is a simpler operation if a fixed press is used for pressing off ► 199 |  13.

 10
Dismounting of non-separable bearings

① Bearing outer ring fitted with sliding seat

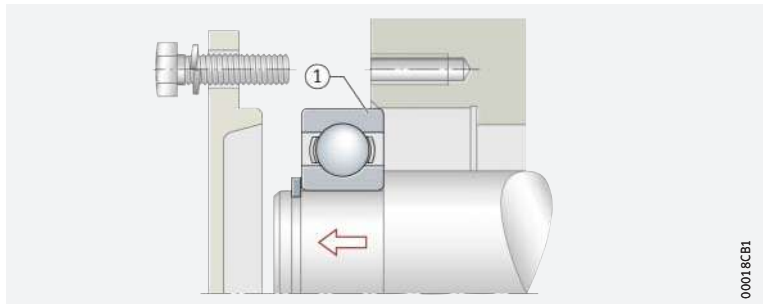

 11
Withdrawal device with tie rods

① Tie rod

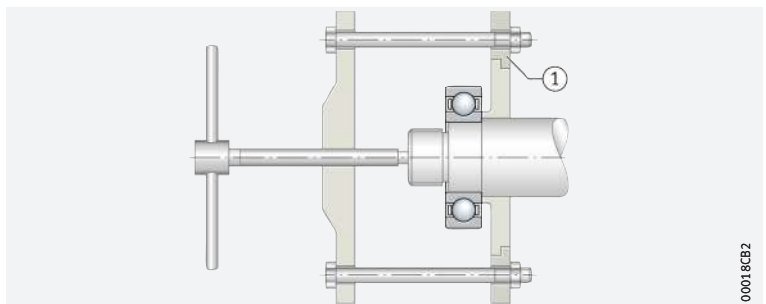



12
Withdrawal device
with adjustable arms

① Extraction slots in shaft shoulder

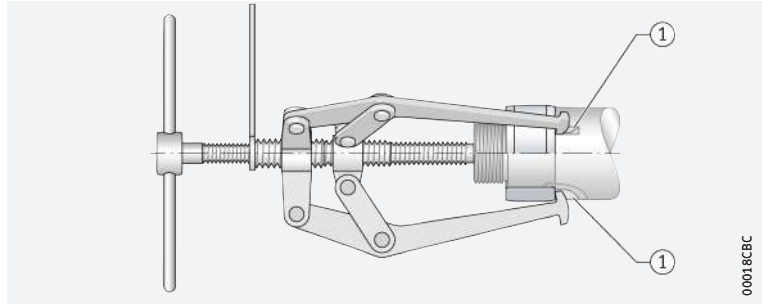

13
Pressing off a ball bearing using
a fixed (stationary) press

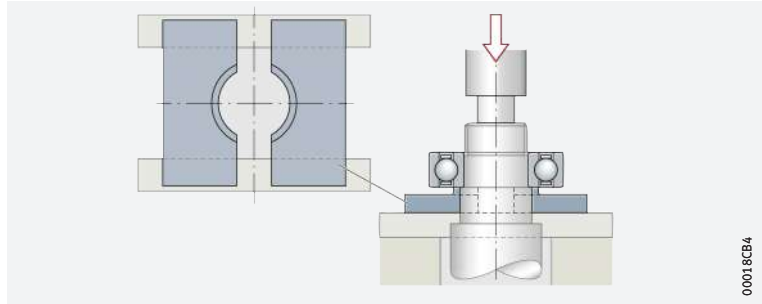

**Ball bearing extractor
with clamping tool**

In cases where the inner ring is in contact with the shaft shoulder and no extraction slots are present there, it is possible to remove ball bearings, tapered roller bearings and cylindrical roller bearings with the aid of an extractor with a clamping tool. In the case of the ball bearing extractor, the finger-shaped extensions of the clamping tool inserted in the extractor engage between the balls on the raceway edge of the inner ring
➤ 199 | ① 14.

The clamping tool is part of a collet that is clamped against the inner ring by means of a conical clamping ring. It is extracted by means of a tensioning spindle. The extractor can also be used to remove bearings, that are still mounted in the housing, from the shaft.

14
Ball bearing extractor
with clamping tool



**Further precautions
for the adjacent construction
when using dismounting
tools**

The examples show that consideration must be given in the design of the adjacent parts to the placement of extraction tools. If the inner ring has a tight fit, its end face must be accessible. This can be achieved, for example, by restricting the shaft shoulder diameter or providing slots in the shaft shoulder ➤ 198 | ① 11 and ➤ 199 | ① 12. Spacer rings or labyrinth rings must be designed such that they do not disrupt extraction.

☞ *Recesses or threaded holes must be provided for extraction screws*

The same applies to the design of the housing. Pot type housings with a rigid end wall are preferred for strength reasons, but cause difficulties in dismounting of the bearing outer ring. If rigid shoulders are present, recesses or threaded holes for extraction screws should be provided
 ► 200 | ☞ 15 and ► 200 | ☞ 16.

☞ **15**
 Slots in housing wall for placement of extraction tool

① Slot

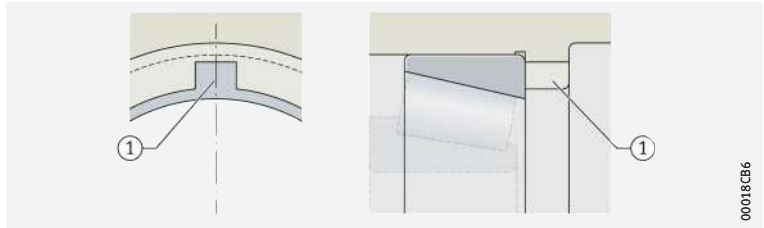

☞ **16**
 Pressure screws in housing wall for extraction of bearing ring

① Pressure screw

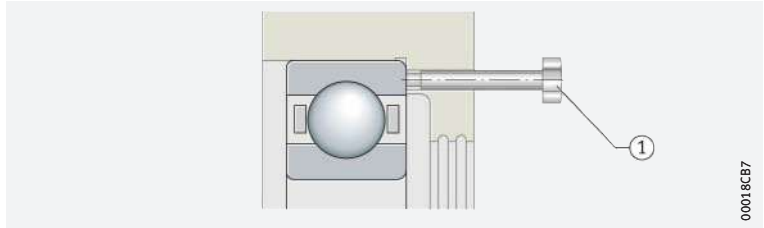

☞ *Separable bearings allow easier dismounting*

Separable bearings

The requirement for easy dismounting of bearings also influences bearing selection. Since they are easy to dismount, separable bearings such as magneto bearings, tapered roller bearings, cylindrical roller bearings and needle roller bearings are often used in preference to other bearing types.

☞ *Method for dismounting a withdrawal sleeve*

Withdrawal sleeve

The withdrawal sleeve is also an accessory to give easier dismounting. For dismounting of the sleeve, it is possible in difficult cases – principally in the case of large size bearings – to use a nut with quenched and tempered pressure screws or a hydraulic nut in place of the extraction nut that is otherwise normally used ► 200 | ☞ 17.

☞ **17**
 Dismounting of a withdrawal sleeve

- ① Extraction nut
- ② Quenched and tempered pressure screws
- ③ Hydraulic nut

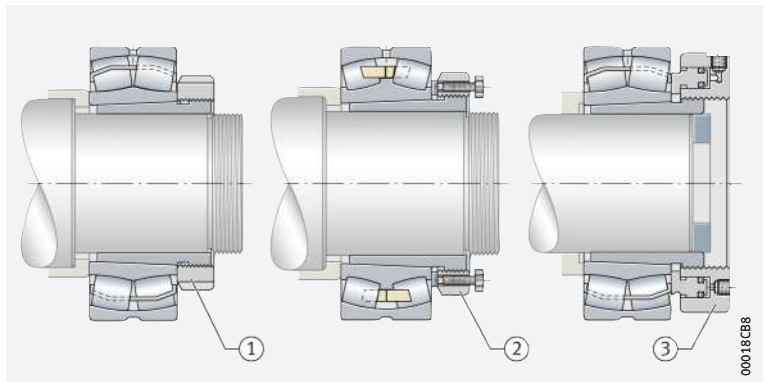



10.6 Special methods for mounting and dismounting

Hydraulic methods or induction heating are suitable for overcoming high adhesive friction

In practice, the high level of adhesive friction in the seating surfaces of tightly fitted bearings often causes problems in extraction. If fretting corrosion has formed in the fit joint, the fit surfaces often undergo fretting during extraction. This can be combatted by means of induction heating or – in the case of larger bearings – by means of hydraulic mounting methods.

Hydraulic methods

Oil between the seating surfaces causes slight expansion of the bearing ring

In hydraulic mounting methods, oil is pressed between the seating surfaces of the tight bearing fit, which slightly expands the bearing ring ▶201|☞ 18. The fluid film eliminates the contact between the fit parts to the point where these can be displaced with little application of force and without the risk of surface damage.

The hydraulic method is only suitable for dismounting in the case of cylindrical fit parts. Conical fit parts can, however, be mounted and removed using the hydraulic method ▶201|☞ 18.



During dismounting, the inner ring becomes loose abruptly. It must therefore be axially secured.

☞ 18

Principle of hydraulic mounting

- ① For cylindrical seating surfaces
- ② For tapered seating surfaces

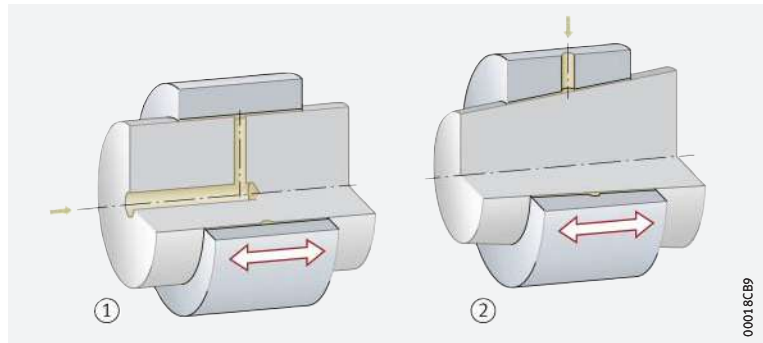

Oil grooves, feed ducts and threaded connectors are necessary

In order to press oil in, oil grooves and feed ducts as well as threaded connectors for the pressure generation devices must be provided ▶201|☞ 19. There are designs of adapter and withdrawal sleeves that already have these ducts ▶202|☞ 20.

☞ 19

Oil ducts and grooves in a tapered shaft

B = bearing width

- ① Oil groove

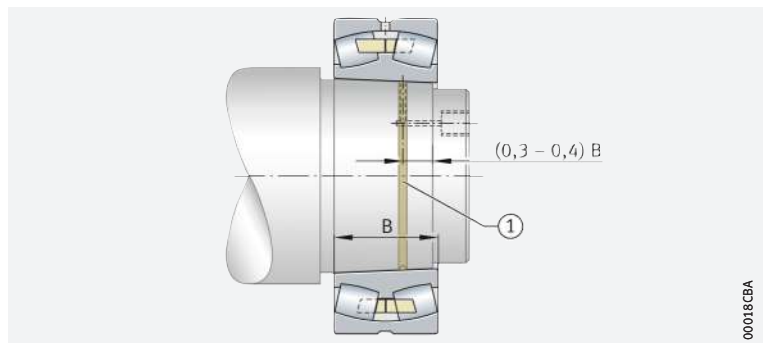

20
 Adapter and withdrawal sleeves
 with oil ducts

① Oil duct

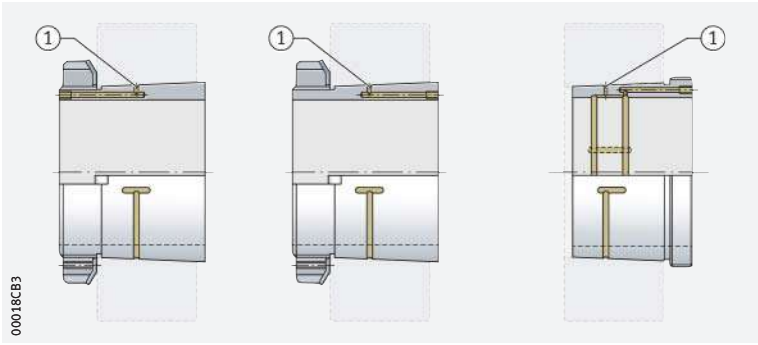

**Oil injector for bearings
 with tapered bore and
 tapered shaft journal**

In the mounting and dismounting of bearings with a tapered bore that are mounted on a tapered shaft journal, a simple oil injector is sufficient **▶ 202** | **21**. If cylindrical fit surfaces are present and adapter or withdrawal sleeves are used, more oil must be pressed in due to the oil loss that occurs at the edges of the fit surfaces. In this case, a twin-stage hand piston pump with an oil pressure of up to 1 600 bar can be used **▶ 202** | **22**.

21
 Oil injector and valve nipples



22
 Twin-stage hand piston pump
 Oil pressure of up to 1 600 bar





Expansion of the rings by induction heating

Induction heating

In addition to the hydraulic method, the expansion of bearing rings by means of induction heating has gained considerable importance for the mounting of rolling bearings and is currently the state of the art. ▶203 | 23 shows a portable device (rigid coil) that is used for the mounting and dismounting of cylindrical roller bearing inner rings. ▶204 | 24 shows the flexible inductor for medium frequency technology. These inductors give safe and reliable heating of rolling bearings or other ring-shaped steel parts even at locations with poor accessibility. Due to the targeted application of heat and the high energy density, medium frequency technology allows short heating times and environmentally acceptable heating.

As a result of rapid local heating, very little heat enters the shaft

If fixed coils are used, a separate device is necessary for each size of ring. Heating takes place so quickly that very little heat enters the shaft during dismounting and the inner rings that previously had a tight fit can easily be loosened from the shaft.

The method is economical if cylindrical roller bearing inner rings are mounted in large quantities or if large size bearings – such as in the replacement of rolls in a rolling mill – must be dismounted and mounted again frequently.

Induction heating devices for sealed and greased bearings

Two further induction heating devices which can be used to heat complete rolling bearings of any type for mounting are shown in ▶204 | 25. These devices can also be used to heat sealed and greased bearings.

The devices operate on the transformer principle, where the bearing acts as a short-circuited secondary winding. As long as the primary current is switched on, a short circuit current is induced in the bearing that heats the bearing to +80 °C or a preselectable temperature. Depending on size, the heating time is between a few seconds and a few minutes.

Heating devices are available for the normal mains voltages. Shrink fit and labyrinth rings or other ring-shaped metallic parts can therefore also be heated by this method.

23
Induction heating device with medium frequency technology

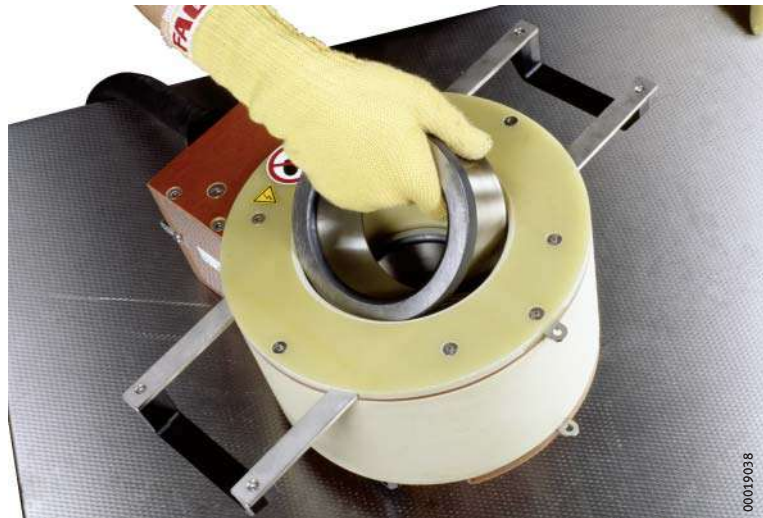

 **24**
*Induction device
with flexible inductor*



 **25**
*Induction heating devices
for the mounting
of complete rolling bearings*

- ① Table top device
for bearings of 10 mm
bore diameter and above
- ② Standalone device
for bearings up to 400 kg mass





































10.7 Tools and methods for the mounting and dismounting of rolling bearings

Whether a rolling bearing is mounted without heating, with heating or using the hydraulic method depends on various factors. The overview in ►206  1 shows which method is suitable in the specific circumstances.

1
 Mounting and dismounting
 methods for rolling bearings

Bearing type		Bearing bore	d mm		
	Deep groove ball bearings		Tapered roller bearings	Cylindrical	 < 80 80 – 200 > 200
	Angular contact ball bearings		Barrel roller bearings		
	Spindle bearings		Spherical roller bearings		
	Four point contact bearings		Self-aligning ball bearings		
	Self-aligning ball bearings		Toroidal roller bearings	Cylindrical	 < 80 80 – 200 > 200
	Cylindrical roller bearings		Needle roller bearings		
	Axial deep groove ball bearings		Axial angular contact ball bearings	Cylindrical	 < 80 80 – 200 > 200
	Axial cylindrical roller bearings		Axial spherical roller bearings		
	Self-aligning ball bearings		Self-aligning ball bearings with adapter sleeve		
	Toroidal roller bearings		Barrel roller bearings		
	Barrel roller bearings with adapter sleeve		Spherical roller bearings	Tapered	 < 80 80 – 200 > 200
	Spherical roller bearings with adapter sleeve		Spherical roller bearings with withdrawal sleeve		
	Adapter sleeve		Withdrawal sleeve		
	Cylindrical roller bearings, double row			Tapered	 < 80 80 – 200 > 200

Symbols



Induction heating device



Heating cabinet



Heating ring



Heating plate



Medium frequency technology



Mounting			Dismounting		
Thermal	Mechanical	Hydraulic	Thermal	Mechanical	Hydraulic

Hammer and mounting sleeve

Double hook wrench

Socket wrench

End cap

Hydraulic nut

Mechanical and hydraulic presses

Nut and hook wrench

Nut and mounting wrench

Withdrawal device

Hydraulic method

Deep groove ball bearings





Matrix for bearing preselection 211

1 Deep groove ball bearings **212**

- 1.1 Bearing design 212
- 1.2 Load carrying capacity 216
- 1.3 Compensation of angular misalignments 217
- 1.4 Lubrication 217
- 1.5 Sealing 218
- 1.6 Speeds 220



1.7	Noise	220	1.17	Mounting and dismounting	231
1.8	Temperature range	221	1.18	Legal notice regarding data freshness	231
1.9	Cages	222	1.19	Further information	231
1.10	Internal clearance	223	Product tables	232	
1.11	Dimensions, tolerances	224	 <i>Deep groove ball bearings, single row</i>	232	
1.12	Suffixes	225	 <i>Deep groove ball bearings, double row</i>	276	
1.13	Structure of bearing designation	226			
1.14	Dimensioning	226			
1.15	Minimum load	228			
1.16	Design of bearing arrangements	228			





Matrix for bearing preselection



The matrix gives an overview of the types and design features of deep groove ball bearings.

It can be used to make a preliminary assessment of whether a bearing is fundamentally suitable for the envisaged application.

The additional information provided in the product chapter (see column "detailed information") and in the Technical principles must, however, be observed in addition to this overview in selection of the bearing.

Design features and suitability			Deep groove ball bearings		
			single row	double row	detailed information
+++ extremely suitable ++ highly suitable + suitable (+) suitable with restrictions - not suitable/not applicable ✓ available					212
Load carrying capacity	radial		++	++	216 1.2
	axial, one direction		+	++	216 1.2
	axial, both directions		+	++	216 1.2
	moments		(+)	+	216 1.2
Compensation of angular misalignments	static		(+)	-	217 1.3
	dynamic		(+)	-	217 1.3
Bearing design	cylindrical bore		✓	✓	212 1.1
	tapered bore		-	-	
	separable		-	-	231 1.17
Lubrication	greased		✓ ¹⁾	✓	217 1.4
Sealing	open		✓	✓	218 1.5
	non-contact		✓	-	218 1.5
	contact		✓	-	218 1.5
Operating temperature in °C		from to	-30 +120 ²⁾	-30 +120	221 1.8
Suitability for	high speeds		+++	+	220 1.6
	high running accuracy		++	+	224 1.11 114
	low-noise running		+++	+++	220 1.7 228 1.16
	high rigidity		+	+	54
	reduced friction		+++	+++	56
	length compensation within bearing		-	-	
	non-locating bearing arrangement		+	+	139
	locating bearing arrangement		++	++	139
X-life bearings			-	-	
Bearing bore d in mm		from to	2 260 ³⁾	10 90	232 276
Product tables		from page	232	276	

1) For sealed bearings only
 2) Valid for bearings with sheet steel sealing shields
 3) Larger catalogue bearings
 GL 1

1 Deep groove ball bearings



Deep groove ball bearings are available in single row and double row designs.

Single row bearings are particularly suitable where:

- high and very high speeds are required
- the bearing arrangement must be operated with very low friction
- very low running noise is required, without reducing the speed, load carrying capacity and operating life of the bearing (Generation C) ▶213
- high demands are made on the sealing of the bearing, without increasing heat generation or limiting the speed (Generation C) ▶218|1.5
- the bearing position is to be designed particularly economically.

Double row bearings can be considered for bearing arrangements where:

- the load carrying capacity of single row deep groove ball bearings is no longer sufficient ▶216
- axial loads in both directions and/or tilting moments must be supported in addition to radial loads ▶216
- a high load carrying capacity is required and the design envelope available in a radial and axial direction is relatively small.

For an overview of other product-specific features, see the Matrix for bearing preselection ▶211.

1
Comparison of standard deep groove ball bearings with bearings of Generation C: running noise, frictional torque

C = bearings of Generation C
 M_R = frictional torque
 n_G = limiting speed

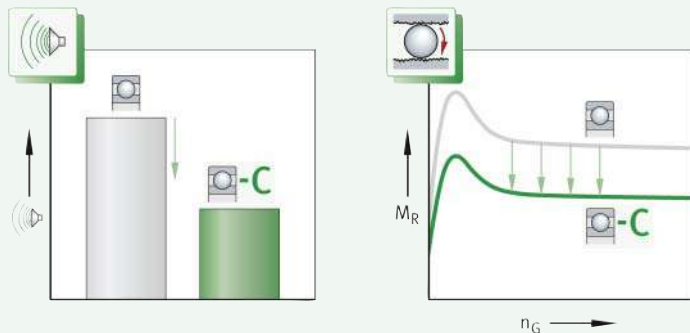

1.1 Bearing design

Design variants

Single row deep groove ball bearings are available as:

- standard bearings ▶213|☐2
- bearings of Generation C ▶214|☐3 and ▶214|☐4
- matched bearing sets ▶215|☐5
- corrosion-resistant bearings ▶215.

Double row deep groove ball bearings are available as:

- standard bearings ▶215|☐6.



Single row deep groove ball bearings are also available in many other designs and sizes, as well as for specific applications, by agreement. Corrosion-resistant bearings ➤ □ TPI 64, larger catalogue bearings ➤ □ GL 1.



☞ *Proven and versatile bearings with high market shares*

Standard bearings

Single row deep groove ball bearings are self-retaining units, which are part of the group of radial ball bearings. The solid outer and inner rings have deep raceway grooves, with shoulders which are not generally interrupted by filling slots ➤ 213 | □ 2. Solid cages made from polyamide PA66 or brass, and sheet metal cages made from steel or brass, are used as standard cages ➤ 222 | □ 4. The bearings are open or sealed. Due to the manufacturing processes used, open bearings, which are also available as sealed versions, can have turned recesses in the outer and inner ring for sealing washers or sealing shields.

Single row deep groove ball bearings are particularly versatile, robust in operation, easy to maintain and very economical. Due to their significant advantages, they are the most widely used rolling bearings worldwide. As a result, Schaeffler also manufactures these bearings in a large number of sizes and designs.

□ 2
Single row deep groove ball bearings, open or sealed

F_r = radial load
 F_a = axial load

- ① Open
- ② Sealing shield on both sides (non-contact)
- ③ Contact seal on both sides

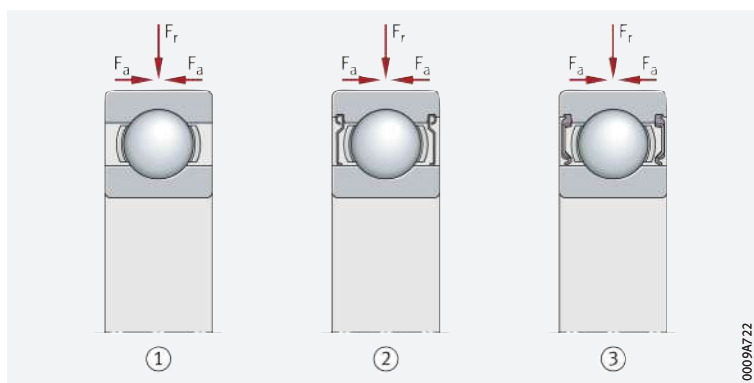

☞ *Gen. C = optimised design of standard bearings*

Deep groove ball bearings of Generation C

Deep groove ball bearings of Generation C correspond in their structure to single row standard deep groove ball bearings, but are specially optimised in relation to:

- significantly quieter running
- even more effective sealing
- a further reduction in the already very low frictional torque.

☞ *Measures to reduce noise*

Schaeffler has analysed the causes of noise generation in deep groove ball bearings using the most advanced methods. On the basis of the findings obtained from these analyses:

- The surface of the raceways has been improved
- The ball quality has been increased
- Osculation has been optimised
- The production tolerances have been reduced
- Deep groove ball bearings have been fitted with new riveted cages made from steel.



The result of this is a noise reduction in Generation C bearings over comparable standard deep groove ball bearings.

☞ *Gen. C = particularly high sealing effect due to new and improved seals*

The quality of the seal not only has a considerable influence on the rating life, but also on the efficiency of a rolling bearing. As a result, the seal must not only protect the running system reliably against contamination, the ingress of moisture and the loss of grease, but also ensure that the total frictional torque and heat generation in the bearing remain low despite the high sealing action. The new sealing shields, non-contact seals and contact seals of Generation C deep groove ball bearings (suffixes Z, BRS, HRS, ELS) demonstrate the success of Schaeffler in performing this difficult technical step effectively ▶ 214 | 3 and ▶ 214 | 4. Description of sealing shields and seals ▶ 218 | 1.5.

☞ *Gen. C = technical and economical advantages of very low friction*

Electric motors, electrical machinery, washing machines, ventilators and electric tools are the preferred application areas of single row deep groove ball bearings. However, in order to facilitate further increases in the efficiency of these motors, machines and tools, the power loss occurring in the bearing arrangements must be reduced.

The above-mentioned measures for reducing noise also resulted, for example, in an approximate reduction in friction of 35%, giving the designer a range of application-specific advantages:

- lower heat generation
- a longer grease operating life
- higher possible speeds
- a longer bearing operating life
- a reduced energy consumption
- lower energy costs
- lower overall cost of the bearing position.

☞ *Gen. C = a leading player among single row deep groove ball bearings*

In summary, this means that, in addition to their technical advantages, bearing positions with deep groove ball bearings of Generation C are also considerably more economical than bearing arrangements with single row standard deep groove ball bearings. Generation C is available in series 60, 62 and 63.



Single row deep groove ball bearings, Generation C, open or with non-contact seals

- ① Open
- ② Sealing shield on both sides (suffix 2Z)
- ③ Non-contact seal on both sides (suffix 2BRS)



Single row deep groove ball bearings, Generation C, contact seals

- ① Contact seal on both sides (suffix 2HRS)
- ② Contact seal on both sides (suffix 2ELS)



Bearing sets in O, X or tandem arrangements

Matched bearing sets

If the load carrying capacity of a single bearing is not sufficient, or the shaft is to be guided axially in both directions with a defined clearance, single row standard deep groove ball bearings are also available as matched bearing sets ▶ 215 | 5.



As the arrangement of the bearing pairs is specific to the application, Schaeffler supplies bearing sets by agreement.



5 Matched bearing sets

F_r = radial load
 F_a = axial load

- ① Set in O arrangement
- ② Set in X arrangement
- ③ Set in tandem arrangement

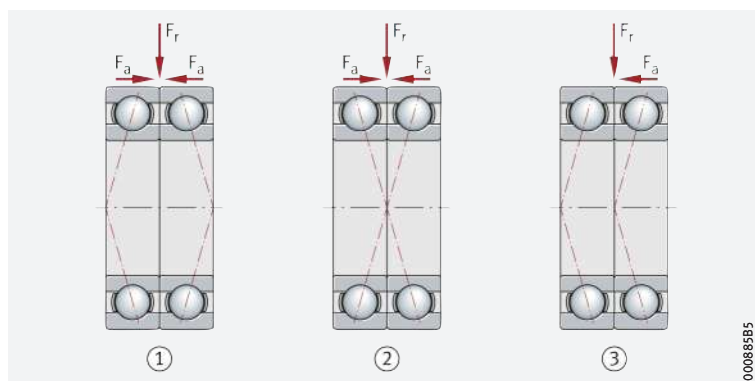

Wide product range

Corrosion-resistant bearings

Corrosion-resistant bearings are suitable where particular requirements for corrosion protection are present. Schaeffler supplies deep groove ball bearings of this type in open and sealed designs.



The load carrying capacity for bearings made from corrosion-resistant steel is slightly lower than for bearings made from rolling bearing steel.



The range of these bearings and housings is described in detail in Technical Product Information TPI 64 ▶ TPI 64.

Double row deep groove ball bearings



Double row deep groove ball bearings of series 42 and 43 correspond in their structure and function to single row deep groove ball bearings arranged in pairs ▶ 215 | 6. They have deep raceway grooves in the bearing rings and a narrow osculation between the raceway grooves and balls. However, they are slightly narrower than two single row deep groove ball bearings of the series 62 and 63 with the same bore and outside diameter.

6 Double row deep groove ball bearing, open

F_r = radial load
 F_a = axial load

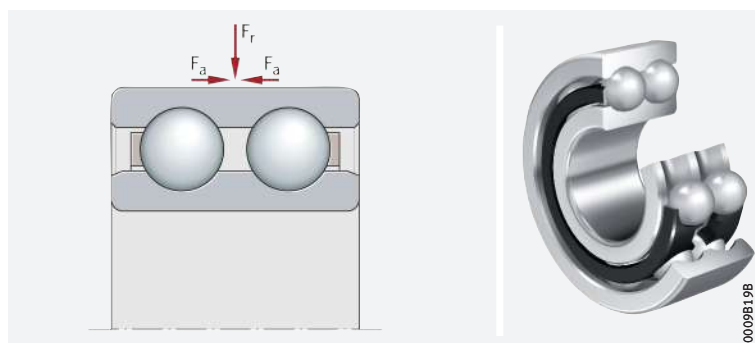

1.2 Load carrying capacity

☞ *Suitable for predominantly radial loads*

☞ *Larger bearing cross-sections permit higher loads*



Single row deep groove ball bearings, comparison of cross-section and load carrying capacity (radial load carrying capacity C_r) for bearings with $d = 40$ mm

C_r = basic dynamic load rating

Single row deep groove ball bearings – radial load carrying capacity

The balls are in contact with the raceways at one point only. Under purely radial load, the contact points between the rolling elements and raceways lie at the centre of the raceway. As a result, the connection between the contact points passes through the radial plane, i.e. the optimum load direction is a purely radial load ▶ 213 | ☞ 2.

The load carrying capacity is dependent on the bearing series. As a result, deep groove ball bearings of series 618 and 619, with their smaller bearing cross-sections, cannot support loads as high as series 60, 62 and 63 – with identical dimensions relative to bore diameter d – with their larger cross-sections ▶ 216 | ☞ 7.

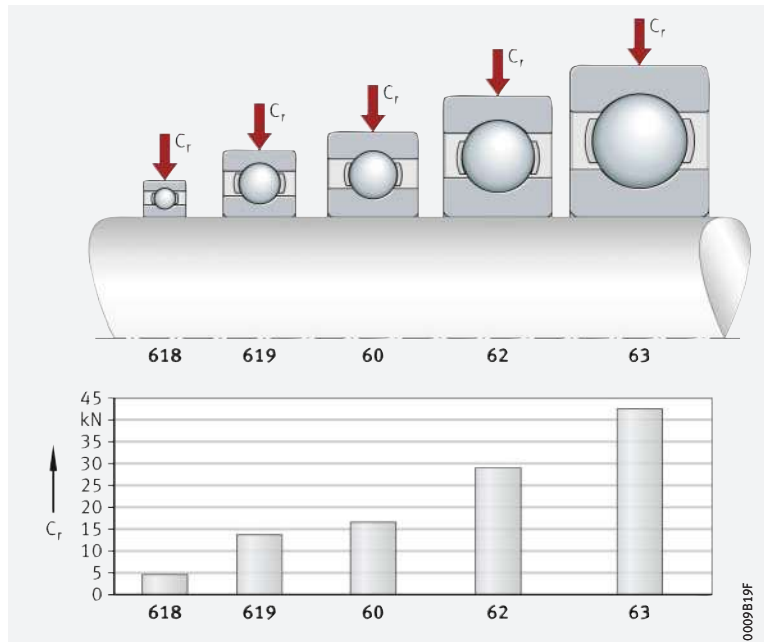

Single row deep groove ball bearings – axial load carrying capacity

☞ *Capable of supporting axial loads in both directions*

Due to the deep raceway grooves in the bearing rings and the narrow osculation between the raceway grooves and balls, single row deep groove ball bearings can support axial loads in both directions ▶ 213 | ☞ 2.

The axial load carrying capacity is dependent, for example, on the bearing size, the internal construction and the operating clearance.

If the axial load is too high, however, this can increase the running noise and considerably reduce the operating life of the bearings.



If there is any uncertainty regarding the axial load carrying capacity of the bearings, please consult Schaeffler.

Double row deep groove ball bearings

☞ *Considerably higher load carrying capacity than single row bearings*

Due to the larger number of rolling elements, double row deep groove ball bearings can be subjected to greater loads than single row deep groove ball bearings with an identical ball set. They can replace two single row deep groove ball bearings if a smaller design envelope width is required.

☞ *Also suitable for tilting moment loads*

Double row deep groove ball bearings can also support tilting moment loads in addition to radial and axial loads ▶ 217 | ☞ 8. They are therefore suitable for particularly short shafts that are supported by only one bearing.

8

Unilateral bearing arrangement of a shaft with a double row deep groove ball bearing (flying bearing arrangement)

F_r = radial load

F_a = axial load

M = tilting moment load

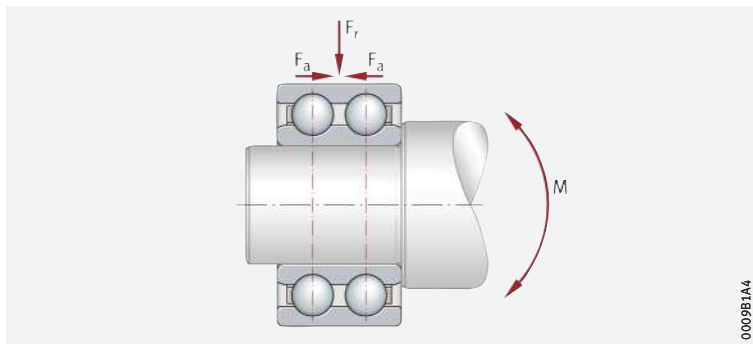

0009E1A4

1.3 Compensation of angular misalignments

The adjustment angle is dependent on the magnitude of the load

Single row deep groove ball bearings – permissible adjustment angle

Single row deep groove ball bearings are only suitable for compensating static angular misalignments to a very limited extent. As a result, the bearing positions must be well aligned. Misalignments shorten the operating life, as they place an additional strain on the bearing. In order to keep these loads at a low level, only small adjustment angles are permissible – dependent on the load – for deep groove ball bearings ▶ 217 | 1.

1

Permissible adjustment angles

Series	Adjustment angle for	
	low loads	high loads
62, 622, 63, 623, 64	5' to 10'	8' to 16'
618, 619, 160, 60	2' to 6'	5' to 10'

Double row deep groove ball bearings



Due to their internal construction, double row deep groove ball bearings do not have an angular adjustment facility. When using these bearings, therefore, misalignments are not permissible.

1.4 Lubrication

Greased bearings are maintenance-free

Single row deep groove ball bearings

Deep groove ball bearings sealed on both sides are lubricated with a high quality lithium soap grease with a mineral oil base, which has good anti-corrosion characteristics. The grease filling is measured so that it is sufficient for the entire life of the bearing. As a result, these bearings are generally maintenance-free.



Do not wash greased bearings out prior to mounting. If mounting is carried out using thermal tools, the bearings should not be heated to a temperature in excess of +80 °C, taking account of the grease filling and seal material. If higher heating temperatures are required, it must be ensured that the permissible upper temperature limits for grease and seals are not exceeded. Schaeffler recommends the use of induction heating devices for heating purposes ▶ 231.

Oil or grease lubrication is possible

Open bearings and bearings with seals on one side are not greased as standard. They must be lubricated with oil or grease. Lubrication is carried out via the end faces of the bearings.

Compatibility with plastic cages

When using bearings with plastic cages, compatibility between the lubricant and the cage material must be ensured if synthetic oils, lubricating greases with a synthetic oil base or lubricants containing a high proportion of EP additives are used.

Observe oil change intervals

Aged oil and additives in the oil can impair the operating life of plastics at high temperatures. As a result, stipulated oil change intervals must be strictly observed.

🔗 *Open bearings are greased*

Double row deep groove ball bearings

As standard, the bearings are lubricated with a high quality lithium soap grease with a mineral oil base and are maintenance-free for most applications.

1.5 Sealing

🔗 *The bearings are available in open and sealed designs*

Single row deep groove ball bearings

Single row deep groove ball bearings are available in open designs, as well as with seals on one or both sides ▶ 213 |  2. In the case of sealed bearings, either non-contact or contact seals are used.

🔗 *Provide seals in the adjacent construction*

In the case of unsealed bearings, sealing of the bearing position must be carried out by the adjacent construction. The sealing system should reliably prevent:

- moisture and contaminants from entering the bearing
- the egress of lubricant from the bearing.

🔗 *For bearing assemblies with high speeds and lower requirements for sealing*

Single row bearings with non-contact seals and sealing shields – standard bearings and Generation C

Non-contact seals are particularly suitable for applications with high speeds and high requirements for low inherent heat generation ▶ 219 |  2. They are free from friction, except for a small amount of lubricant friction in the sealing gap. As a rule, non-contact seals do not undergo wear and therefore have an unlimited operating life. Deep groove ball bearings with non-contact seals on one or both sides have the suffixes RZ and 2RZ, or BRS and 2BRS; the suffixes Z and 2Z indicate seals on one or both sides with sealing shields.

🔗 *Z sealing shields for standard bearings and for bearings of Gen. C*

Z sealing shields are made from sheet steel. They sit securely in the outer ring and form a narrow, non-contact seal gap relative to the surface of the inner ring ▶ 219 |  2. This sealing arrangement is particularly suitable for applications with a rotating inner ring, high to very high speeds and low contamination impact.

🔗 *RZ seals for standard bearings of series 618 and 619*

RZ seals are rubberised sealing washers with a sheet steel reinforcement, which sit securely in the outer ring and form a narrow, non-contact seal gap relative to the surface of the inner ring ▶ 219 |  2.

🔗 *BRS seals for bearings of Gen. C*

BRS seals are rubberised sealing washers with a sheet steel reinforcement, which sit securely in the outer ring and form a narrow, non-contact seal gap relative to the surface of the inner ring ▶ 219 |  2. The seal is securely anchored in the outer ring. A recess incorporated in the inner ring forms a labyrinth in conjunction with the seal lip, which is filled with grease. The frictional behaviour of this seal is comparable with that of the Z sealing shield, however, the protection against ingress of dust and egress of lubricant is higher.

🔗 *For lower speeds and higher requirements for sealing action*

Single row bearings with non-contact seals – standard bearings and Generation C

As these seals are in contact with a defined contact pressure against their sliding surface, they provide very good sealing action against the egress of lubricant and ingress of moisture and dust. Attention must, however, be paid to the loss of energy resulting from friction at the sealing contact. Furthermore, in bearings with contact seals, the bearing speed is restricted by the permissible sliding velocity at the seal lip, i.e. the speed suitability of these bearings is lower than for open bearings or bearings with non-contact seals.

🔗 *RSR seals, for standard bearings*

RSR seals are elastomer lip seals with a sheet steel reinforcement ▶ 219 |  2. One seal lip is in radial contact with the inner ring.

HRS and ELS seals for bearings of Gen. C

HRS and ELS seals are securely anchored in a recess in the outer ring. The sealing material is vulcanised onto a sheet steel reinforcement >219| 2. The sealing washer, together with the inner ring, forms an axial sealing system. In addition, the outer non-contact lip forms a protective labyrinth with the inner ring. An additional increase in the sealing action is also provided by the film of grease between the two seal lips. With this sealing arrangement, higher speeds can be achieved than with conventional RSR seals, as the frictional torque and thus the heat generation in the bearing is lower.











Generation C deep groove ball bearings with contact seals are supplied with HRS seals as standard. ELS seals are available for these bearings by agreement.



2
Seal characteristics – standard bearings and Generation C

- +++ = excellent
- ++ = very good
- + = good
- 0 = satisfactory
- = unsatisfactory

Suffix	Type of seal	Seal characteristic				
		low-friction running	high speeds	sealing integrity against ingress of water	sealing integrity against ingress of dust	sealing integrity against loss of grease
-	 open (without seals)	+++	+++	-	-	-
Z, 2Z	 non-contact (sheet metal), for standard bearings and Gen. C	++	+++	0	0	0
RZ, 2RZ	 non-contact (elastomer), for standard bearings	++	+++	0	0	0
BRS, 2BRS	 non-contact (elastomer), for Gen. C	++	+++	0	+	+
HRS, 2HRS	 contact (elastomer), for Gen. C	0	+	++	++	++
RSR, 2RSR	 contact (elastomer), for standard bearings	0	+	+	++	++
ELS, 2ELS	 contact (elastomer), for Gen. C	+	++	++	+++	+++

 *The bearings are of an open design*

Double row deep groove ball bearings

Double row deep groove ball bearings are not sealed. As a result, sealing of the bearing position must be carried out by the adjacent construction ► 218 | 1.5.

1.6 Speeds

 *Limiting speeds and reference speeds in the product tables*

Two speeds are generally indicated in the product tables ► 232 | :

- the kinematic limiting speed n_G
- the thermal speed rating $n_{\theta r}$.

Limiting speeds



The limiting speed n_G is the kinematically permissible speed of the bearing. Even under favourable mounting and operating conditions, this value should not be exceeded without prior consultation with Schaeffler ► 64.

The values given in the product tables are valid for oil lubrication in the case of bearings without seals or shields and for grease lubrication where bearings are supplied greased and with seals or shields.

 *Values for grease lubrication*

For grease lubrication, 85% of the value stated in the product tables is permissible in each case.

Reference speeds

 *$n_{\theta r}$ is used to calculate n_{θ}*

The thermal speed rating $n_{\theta r}$ is not an application-oriented speed limit, but is a calculated ancillary value for determining the thermally safe operating speed n_{θ} ► 64.

 *Bearings with contact seals*

For bearings with contact seals, no reference speeds are defined in accordance with DIN ISO 15312:2004. As a result, only the limiting speed n_G is given in the product tables for these bearings.

Speeds for bearing sets



For matched bearing pairs in an O, X or tandem arrangement, the speed must be limited to approx. 80% of the individual bearings. More accurate speed data for a specific application can be requested from Schaeffler.

1.7 Noise

The Schaeffler Noise Index (SGI) has been developed as a new feature for comparing the noise level of different bearing types and series. As a result, a noise evaluation of rolling bearings can now be carried out for the first time.

Schaeffler Noise Index

The SGI value is based on the maximum permissible noise level of a bearing in accordance with internal standards, which is calculated on the basis of ISO 15242. In order that different bearing types and series can be compared, the SGI value is plotted against the basic static load rating C_0 .

This permits direct comparisons between bearings with the same load carrying capacity. The upper limit value is given in each of the diagrams. This means that the average noise level of the bearings is lower than illustrated in the diagram.

! The Schaeffler Noise Index is an additional performance characteristic in the selection of bearings for noise-sensitive applications. The specific suitability of a bearing for an application in terms of installation space, load carrying capacity or speed limit for example, must be checked independently of this.

👁️ The Noise Index is currently available for the main series. Additional series will be updated and introduced in subsequent publications.

Further information:

■ **medias** ➤ <https://medias.schaeffler.com>.



9
Schaeffler Noise Index
for deep groove ball bearings

S_GI = Schaeffler Noise Index
C₀ = basic static load rating

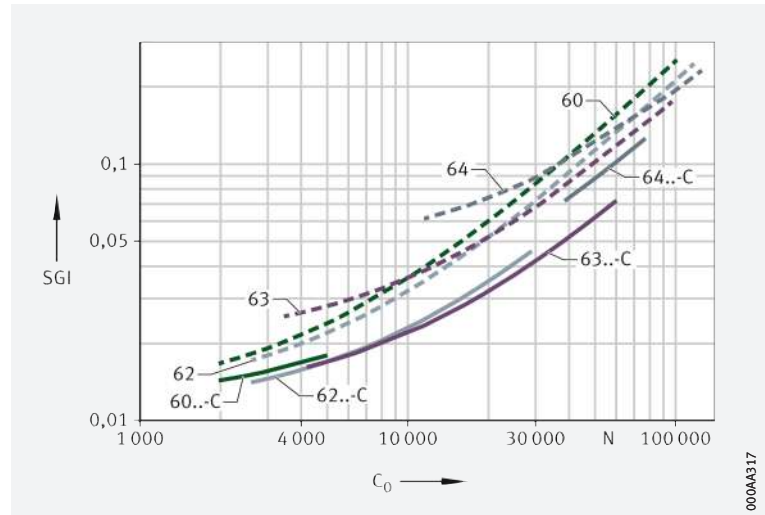

000AA317

1.8 Temperature range

👁️ Limiting values

The operating temperature of the bearings is limited by:

- the dimensional stability of the bearing rings and rolling elements
- the cage
- the lubricant
- the seals.

Possible operating temperatures of single row deep groove ball bearings ➤ 221 | 3.

3
Permissible temperature ranges

Operating temperature	Open deep groove ball bearings		Sealed deep groove ball bearings	
	with brass or sheet steel cage	with polyamide cage PA66	with seals BRS, 2BRS, ELS, 2ELS, HRS, 2HRS, RSR, 2RSR, RZ, 2RZ	with gap seals Z, 2Z
🌡️	D ≤ 90 mm, -30 °C to +120 °C ¹⁾	-30 °C to +120 °C	-30 °C to +110 °C, limited by the lubricant, cage material and seal material	-30 °C to +120 °C, limited by the lubricant, cage material and seal material
	90 mm < D ≤ 240 mm, -30 °C to +150 °C ¹⁾			
	D > 240 mm, -30 °C to +200 °C ¹⁾			

¹⁾ By agreement, dimensionally stabilised for higher temperatures.



In the event of anticipated temperatures which lie outside the stated values, please contact Schaeffler.

1.9 Cages

Single row bearings: sheet steel or solid brass cages are used as standard

Standard cages for single row deep groove ball bearings are made from sheet steel or brass ▶ 222| 4. Other cage designs are available ▶ 225| 8. With such cages, however, suitability for high speeds and temperatures as well as the basic load ratings may differ from the values for the bearings with standard cages.

 4
Cage, cage suffix, bore code for single row deep groove ball bearings

Bearing series	Sheet steel cage	Sheet brass cage	Solid brass cage
	Bore code		
60	up to 34	–	from 36
62	up to 30	–	from 32
63	up to 26, 30	–	28, from 32
64	up to 14	–	from 15
160	up to 52	–	from 56
618	up to 08, 26, 30 to 56	09 to 24, 28	from 60
619	up to 18, 21, 32 to 48	–	26
622	up to 12	–	–
623	up to 10	–	–

Double row bearings

Double row deep groove ball bearings have cages made from glass fibre reinforced polyamide PA66.



For high continuous temperatures and applications with difficult operating conditions, bearings with brass or sheet steel cages should be used. If there is any uncertainty regarding cage suitability, please consult Schaeffler.

Riveted sheet metal cages used as standard

Cages for bearings of Generation C

In bearings of Generation C, a noise-optimised, riveted sheet steel cage is used as the standard cage. This cage design does not have a cage suffix in the bearing designation.



The bearings are also available with cages made from glass fibre reinforced polyamide PA66 by agreement.

1.10 Internal clearance

 The standard is CN

Radial internal clearance

Deep groove ball bearings of basic design and bearings of Generation C are manufactured as standard with radial internal clearance CN (normal) ▶ 223  5. CN is not stated in the designation.

The bearings are also available with the smaller internal clearance C2 and with the larger internal clearance C3 and C4.

 CM also available for smaller bore diameters

Deep groove ball bearings with a bore diameter $10 \leq d \leq 50$ are also available with the more closely tolerated bearing internal clearance CM (specifically for use in electric motors) ▶ 223  6.



The values for radial internal clearance (not CM) correspond to DIN 620-4:2004 (ISO 5753-1:2009). They are valid for bearings which are free from load and measurement forces (without elastic deformation).

 5
Radial internal clearance of deep groove ball bearings – standard bearings and Gen. C

Nominal bore diameter d mm		Radial internal clearance							
		C2 (Group 2) μm		CN (Group N) μm		C3 (Group 3) μm		C4 (Group 4) μm	
over	incl.	min.	max.	min.	max.	min.	max.	min.	max.
1,5	6	0	7	2	13	8	23	–	–
6	10	0	7	2	13	8	23	14	29
10	18	0	9	3	18	11	25	18	33
18	24	0	10	5	20	13	28	20	36
24	30	1	11	5	20	13	28	23	41
30	40	1	11	6	20	15	33	28	46
40	50	1	11	6	23	18	36	30	51
50	65	1	15	8	28	23	43	38	61
65	80	1	15	10	30	25	51	46	71
80	100	1	18	12	36	30	58	53	84
100	120	2	20	15	41	36	66	61	97
120	140	2	23	18	48	41	81	71	114
140	160	2	23	18	53	46	91	81	130
160	180	2	25	20	61	53	102	91	147
180	200	2	30	25	71	63	117	107	163
200	225	2	35	25	85	75	140	125	195
225	250	2	40	30	95	85	160	145	225
250	280	2	45	35	105	90	170	155	245

 6
Radial internal clearance CM

Nominal bore diameter d mm		Radial internal clearance CM μm	
over	incl.	min.	max.
10	18	4	11
18	24	5	12
24	30	5	12
30	40	9	17
40	50	9	17

1.11 Dimensions, tolerances

Dimension standards



The main dimensions of single row deep groove ball bearings correspond to DIN 625-1:2011. Nominal dimensions of single row deep groove ball bearings ▶ 232 | .

The main dimensions of double row deep groove ball bearings correspond to DIN 625-3:2011. Nominal dimensions of double row deep groove ball bearings ▶ 276 | .

Chamfer dimensions



The limiting dimensions for chamfer dimensions correspond to DIN 620-6:2004. Overview and limiting values ▶ 135 | 7.11. Nominal value of chamfer dimension ▶ 232 | .

Tolerances for standard bearings



The tolerances for the dimensional and running accuracy of single and double row standard bearings correspond to tolerance class Normal in accordance with ISO 492:2014. Bearings with a higher accuracy are available by agreement. Tolerance values in accordance with ISO 492 ▶ 122 | 8.



The width tolerance of matched bearings deviates from the values in the above-mentioned standard ▶ 224 | 7.



Width tolerance of bearing rings in matched bearings

Tolerance symbols ▶ 122 |

U = upper limit deviation

L = lower limit deviation

Nominal bore diameter d mm		Width deviation $t_{\Delta Bs}$ μm	
over	incl.	U	L
–	18	0	–250
18	50	0	–300
50	80	0	–450
80	120	0	–550
120	180	0	–750
180	250	0	–950
250	315	0	–1050

Tolerances for bearings of Generation C



The dimensional and running tolerances correspond to tolerance class 6 in accordance with ISO 492:2014. Bearings with a higher accuracy are available by agreement. Tolerance values in accordance with ISO 492 ▶ 124 | 11.

1.12 Suffixes

For a description of the suffixes used in this chapter ▶ 225 | 8, ▶ 225 | 9 and **medias** interchange ▶ <https://www.schaeffler.de/std/1D52>.



Further special designs of deep groove ball bearings are available by agreement.



8
Suffixes and corresponding descriptions, single row deep groove ball bearings

Suffix	Description of suffix	
C	Deep groove ball bearing, Generation C	Standard
M	Solid brass cage, ball-guided	
MA	Solid brass cage, guided on outer ring rib	Available by agreement
MB	Solid brass cage, guided on inner ring rib	
C2	Radial internal clearance C2 (smaller than normal)	Available by agreement
C3	Radial internal clearance C3 (larger than normal)	
C4	Radial internal clearance C4 (larger than C3)	
CM	Radial internal clearance more closely toleranced than normal	
2BRS	Non-contact seal on both sides (labyrinth seal)	Standard for Generation C
2HRS	Contact seal on both sides (lip seal)	Standard for Generation C
2RSR	Contact seal on both sides (lip seal)	Standard
2RZ	Non-contact seal on both sides (rubberised gap seal)	Standard
2Z	Non-contact sealing shield on both sides (sheet metal gap seal)	Standard
BRS	Non-contact seal on one side (labyrinth seal)	Available by agreement
ELS	Contact seal on one side (lip seal)	Available by agreement for Generation C
2ELS	Contact seal on both sides (lip seal)	Available by agreement for Generation C
RSR	Contact seal on one side (lip seal)	Available by agreement
RZ	Non-contact seal on one side (rubberised gap seal)	Available by agreement
TVH	Solid cage made from glass fibre reinforced polyamide PA66	Available by agreement
Y	Sheet brass cage	Available by agreement
Z	Non-contact sealing shield on one side (sheet metal gap seal)	Available by agreement
S0	Dimensionally stabilised bearing for operating temperatures up to +150 °C	Available by agreement
S1	Dimensionally stabilised bearing for operating temperatures up to +200 °C	Available by agreement
S2	Dimensionally stabilised bearing for operating temperatures up to +250 °C	Available by agreement



9
Suffixes and corresponding descriptions, double row deep groove ball bearings

Suffix	Description of suffix	
B	Modified internal construction	Standard
TVH	Solid cage made from glass fibre reinforced polyamide PA66	Standard



1.13 Structure of bearing designation

Examples of composition of bearing designation

The designation of bearings follows a set model. Examples ▶ 226 | 10, ▶ 226 | 11 and ▶ 226 | 12. The composition of designations is subject to DIN 623-1 ▶ 102 | 10.

10
Single row deep groove ball bearing, open: designation structure

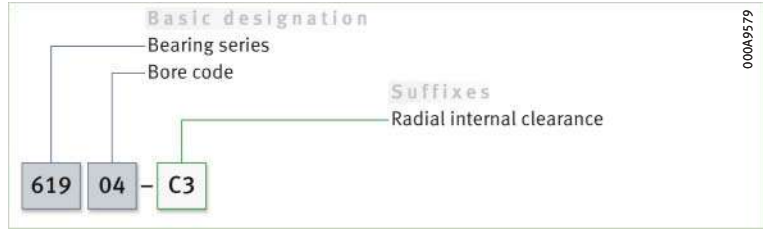

11
Single row deep groove ball bearing, sealed, Generation C: designation structure

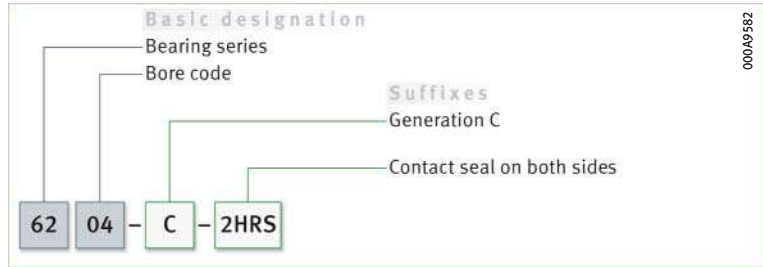

12
Double row deep groove ball bearing, open: designation structure

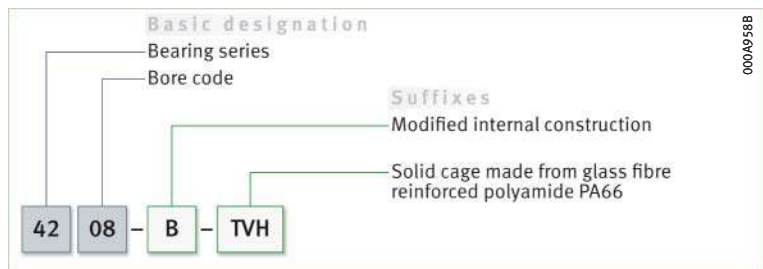

1.14 Dimensioning

Equivalent dynamic bearing load

$P = F_r$ under purely radial load of constant magnitude and direction

P is a substitute force for combined load and various load cases

$F_a/F_r \leq e$ or $F_a/F_r > e$

The basic rating life equation $L = (C_r/P)^P$ used in the dimensioning of bearings under dynamic load assumes a load of constant magnitude and direction. In radial bearings, this is a purely radial load F_r . If this condition is met, the bearing load F_r is used in the rating life equation for P ($P = F_r$). If this condition is not met, a constant radial force must first be determined for the rating life calculation that (in relation to the rating life) represents an equivalent load. This force is known as the equivalent dynamic bearing load P .

The calculation of P is dependent on the load ratio F_a/F_r and the calculation factor e ▶ 227 | 1 and ▶ 227 | 2.

f1 Equivalent dynamic load

$$\frac{F_a}{F_r} \leq e \Rightarrow P = F_r$$

f2 Equivalent dynamic load

$$\frac{F_a}{F_r} > e \Rightarrow P = X \cdot F_r + Y \cdot F_a$$

Legend

P	N	Equivalent dynamic bearing load
F_r	N	Radial load
F_a	N	Axial load
e, X, Y	-	Factors ▶ 227 10.



The values in accordance with ▶ 227 | 10 are valid for normal fits (shaft manufactured to j5 or k5, housing bore manufactured to J6). If the calculation values lie between the stated values (e.g. in the case of 0,4), then read off the table values for 0,3 and 0,5 and determine the intermediate values using linear interpolation.

10 Factors e, X and Y

$\frac{f_0 \cdot F_a}{C_{0r}}$	Factor for radial internal clearance CN		
	e	X	Y
0,3	0,22	0,56	2
0,5	0,24	0,56	1,8
0,9	0,28	0,56	1,58
1,6	0,32	0,56	1,4
3	0,36	0,56	1,2
6	0,43	0,56	1

Legend

C_{0r}	N	Basic static load rating ▶ 232 10
f_0	-	Factor ▶ 232 10
F_a	N	Axial load.

Equivalent static bearing load

For deep groove ball bearings under static load ▶ 227 | f3 and ▶ 227 | f4. The calculation of P_0 is dependent on the load ratio F_{0a}/F_{0r} and the factor 0,8.

f3 Equivalent static load

$$\frac{F_{0a}}{F_{0r}} \leq 0,8 \Rightarrow P_0 = F_{0r}$$

f4 Equivalent static load

$$\frac{F_{0a}}{F_{0r}} > 0,8 \Rightarrow P_0 = 0,6 \cdot F_{0r} + 0,5 \cdot F_{0a}$$

Legend

P_0	N	Equivalent static bearing load
F_{0r}, F_{0a}	N	Largest radial or axial load present (maximum load).

Static load safety factor

In addition to the basic rating life L_{10h} , it is also always necessary to check the static load safety factor S_0 ▶ 227 | f5.

f5 Static load safety factor

$$S_0 = \frac{C_0}{P_0}$$

Legend

S_0	-	Static load safety factor
C_0	N	Basic static load rating
P_0	N	Equivalent static bearing load.

1.15 Minimum load

In order to prevent damage due to slippage, a minimum radial load of $P > C_{0r}/100$ is required

In order that no slippage occurs between the contact partners, the deep groove ball bearings must be constantly subjected to a sufficiently high load. Based on experience, a minimum radial load of the order of $P > C_{0r}/100$ is thus necessary. In most cases, however, the radial load is already higher than the requisite minimum load due to the weight of the supported parts and the external forces.



If the minimum radial load is lower than indicated above, please consult Schaeffler.

1.16 Design of bearing arrangements

Support bearing rings over their entire circumference and width

In order to allow full utilisation of the load carrying capacity of the bearings and thus also achieve the requisite rating life, the bearing rings must be rigidly and uniformly supported by means of contact surfaces over their entire circumference and over the entire width of the raceway. The seating and contact surfaces should not be interrupted by grooves, holes or other recesses. The accuracy of mating parts must meet specific requirements [▶ 229 | 11](#) to [▶ 230 | 13](#).

For secure radial location, tight fits are necessary

Radial location of bearings – fit recommendations

In addition to supporting the rings adequately, the bearings must also be securely located in a radial direction, to prevent creep of the bearing rings on the mating parts under load. This is generally achieved by means of tight fits between the bearing rings and the mating parts. If the rings are not secured adequately or correctly, this can cause severe damage to the bearings and adjacent machine parts. Influencing factors, such as the conditions of rotation, magnitude of the load, internal clearance, temperature conditions, design of the mating parts and the mounting and dismantling options must be taken into consideration in the selection of fits.



If shock type loads occur, tight fits (transition fit or interference fit) are required to prevent the rings from coming loose at any point. Clearance, transition or interference fits [▶ 150 | 6](#) and [▶ 158 | 7](#).



The following information provided in Technical principles must be taken into consideration in the design of bearing arrangements:

- conditions of rotation [▶ 145](#)
- tolerance classes for cylindrical shaft seats (radial bearings) [▶ 147 | 2](#)
- shaft fits [▶ 150 | 6](#)
- tolerance classes for bearing seats in housings (radial bearings) [▶ 148 | 4](#)
- housing fits [▶ 158 | 7](#).

The bearings must also be securely located in an axial direction

Axial location of bearings – location methods

As a tight fit alone is not normally sufficient to also locate the bearing rings securely on the shaft and in the housing bore in an axial direction, this must usually be achieved by means of an additional axial location or retention method. The axial location of the bearing rings must be matched to the type of bearing arrangement. Shaft and housing shoulders, housing covers, nuts, spacer rings and retaining rings etc., are fundamentally suitable.

*Example:
single row deep groove
ball bearing,
bearing arrangement
in an electric motor*

Axial adjustment by means of spring element to reduce noise

If the bearing arrangement is to run particularly quietly, this can be achieved economically with commonly available spring elements ▶ 229 | 13. The bearings in the figure must only support guidance forces in an axial direction. The inner rings have a tight fit on the shaft and are abutted on the shaft shoulders. The outer rings are mounted with a sliding seat. A spring washer is fitted between the outer ring of the right hand bearing and the cover collar. The bearings are thus axially adjusted by the tensioned springs. This achieves particularly smooth running.



13

Bearing arrangement axially adjusted with a spring washer

- ① Deep groove ball bearing
- ② Spring washer
- ③ Cover

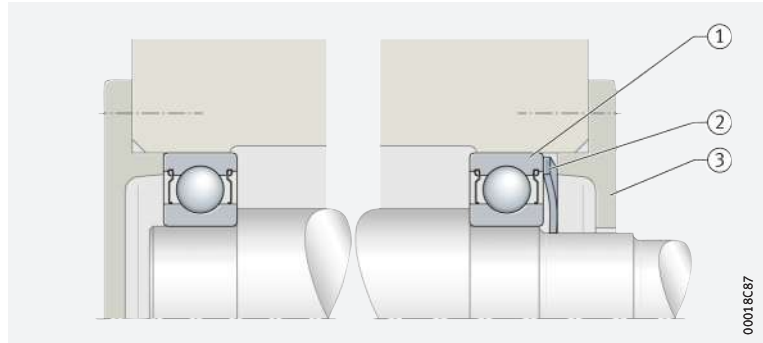

00018C87

For bearings with tolerance class Normal, a minimum of IT6 should be provided for the shaft seat and a minimum of IT7 for the housing seat

Dimensional, geometrical and running accuracy of the bearing seats

The accuracy of the cylindrical bearing seat on the shaft and in the housing should correspond to the accuracy of the bearing used. For deep groove ball bearings with the tolerance class Normal, the shaft seat should correspond to a minimum of standard tolerance grade IT6 and the housing seat to a minimum of IT7; with tolerance class 6, the shaft seat should correspond to a minimum of IT5 and the housing seat to a minimum of IT6. Guide values for the geometrical and positional tolerances of bearing seating surfaces ▶ 229 | 11, tolerances t_1 to t_3 in accordance with ▶ 168 | 11. Numerical values for IT grades ▶ 230 | 12.

11

Guide values for the geometrical and positional tolerances of bearing seating surfaces

Bearing tolerance class		Bearing seating surface	Standard tolerance grades to ISO 286-1 (IT grades)			
to ISO 492	to DIN 620		Diameter tolerance	Roundness tolerance	Parallelism tolerance	Total axial runout tolerance of abutment shoulder
				t_1	t_2	t_3
Normal	PN (P0)	Shaft	IT6 (IT5)	Circumferential load	Circumferential load	IT4
				IT4/2	IT4/2	
		Housing	IT7 (IT6)	Circumferential load	Circumferential load	IT5
				IT5/2	IT5/2	
6	P6	Shaft	IT5	Circumferential load	Circumferential load	IT3
				IT3/2	IT3/2	
		Housing	IT6	Circumferential load	Circumferential load	IT4
				IT4/2	IT4/2	

12
Numerical values
for ISO standard tolerances
(IT grades) to ISO 286-1:2010

IT grade	Nominal dimension in mm								
	over	–	3	6	10	18	30	50	80
	incl.	3	6	10	18	30	50	80	120
Values in μm									
IT3	2	2,5	2,5	3	4	4	5	6	
IT4	3	4	4	5	6	7	8	10	
IT5	4	5	6	8	9	11	13	15	
IT6	6	8	9	11	13	16	19	22	
IT7	10	12	15	18	21	25	30	35	
continued ▼									

12
Numerical values
for ISO standard tolerances
(IT grades) to ISO 286-1:2010

IT grade	Nominal dimension in mm								
	over	120	180	250	315	400	500	630	800
	incl.	180	250	315	400	500	630	800	1000
Values in μm									
IT3	8	10	12	13	15	16	18	21	
IT4	12	14	16	18	20	22	25	28	
IT5	18	20	23	25	27	32	36	40	
IT6	25	29	32	36	40	44	50	56	
IT7	40	46	52	57	63	70	80	90	
continued ▲									

Roughness of cylindrical bearing seating surfaces

☞ *Ra must not be too high*

The roughness of the bearing seats must be matched to the tolerance class of the bearings. The mean roughness value Ra must not be too high, in order to maintain the interference loss within limits. The shafts must be ground, while the bores must be precision turned. Guide values as a function of the IT grade of bearing seating surfaces ▶ 230 | 13.

13
Roughness values
for cylindrical bearing seating
surfaces – guide values

Nominal diameter of the bearing seat d (D) mm		Recommended mean roughness value for ground bearing seats Ramax			
		μm			
		Diameter tolerance (IT grade)			
over	incl.	IT7	IT6	IT5	IT4
–	80	1,6	0,8	0,4	0,2
80	500	1,6	1,6	0,8	0,4
500	1 250	3,2 ¹⁾	1,6	1,6	0,8

¹⁾ For the mounting of bearings using the hydraulic method, a value $Ra = 1,6 \mu\text{m}$ must not be exceeded.

Mounting dimensions for the contact surfaces of bearing rings

☞ *The contact surfaces for the rings must be of sufficient height*

The mounting dimensions of the shaft and housing shoulders, and spacer rings etc., must ensure that the contact surfaces for the bearing rings are of sufficient height. However, they must also reliably prevent rotating parts of the bearing from grazing stationary parts. Proven mounting dimensions for the radii and diameters of the abutment shoulders are given in the product tables. These dimensions are limiting dimensions (maximum or minimum dimensions); the actual values should not be higher or lower than specified.

1.17 Mounting and dismounting



The mounting and dismounting options for deep groove ball bearings, by thermal, hydraulic or mechanical methods, must be taken into consideration in the design of the bearing position.

☞ *Ensure that the bearings are not damaged during mounting.*

Deep groove ball bearings are not separable. In the mounting of non-separable bearings, the mounting forces must always be applied to the bearing ring with a tight fit.



☞ *Rolling bearings must be handled with great care*

Schaeffler Mounting Handbook

Rolling bearings are well-proven precision machine elements for the design of economical and reliable bearing arrangements, which offer high operational security. In order that these products can function correctly and achieve the envisaged operating life without detrimental effect, they must be handled with care.



The Schaeffler Mounting Handbook MH 1 gives comprehensive information about the correct storage, mounting, dismounting and maintenance of rotary rolling bearings ► <https://www.schaeffler.de/std/1D53>. It also provides information which should be observed by the designer, in relation to the mounting, dismounting and maintenance of bearings, in the original design of the bearing position. This book is available from Schaeffler on request.

1.18 Legal notice regarding data freshness

☞ *The further development of products may also result in technical changes to catalogue products*

Of central interest to Schaeffler is the further development and optimisation of its products and the satisfaction of its customers. In order that you, as the customer, can keep yourself optimally informed about the progress that is being made here and with regard to the current technical status of the products, we publish any product changes which differ from the printed version in our electronic product catalogue.



We therefore reserve the right to make changes to the data and illustrations in this catalogue. This catalogue reflects the status at the time of printing. More recent publications released by us (as printed or digital media) will automatically precede this catalogue if they involve the same subject. Therefore, please always use our electronic product catalogue to check whether more up-to-date information or modification notices exist for your desired product.

Link to electronic product catalogue



The following link will take you to the Schaeffler electronic product catalogue: ► <https://medias.schaeffler.com>.

1.19 Further information



In addition to the data in this chapter, the following chapters in Technical principles must also be observed in the design of bearing arrangements:

- Determining the bearing size ► 34
- Rigidity ► 54
- Friction and increases in temperature ► 56
- Speeds ► 64
- Bearing data ► 97
- Lubrication ► 70
- Sealing ► 182
- Design of bearing arrangements ► 139
- Mounting and dismounting ► 191.



Deep groove ball bearings

Single row

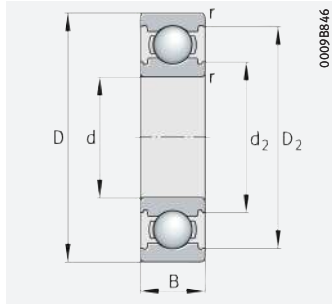

Generation C, open

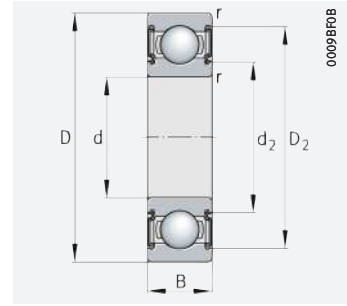

With seal 2BRS, 2HRS, 2Z

d = 2 – 9 mm

Main dimensions			Basic load ratings		Fatigue limit load C_{ur} N	Limiting speed n_G min ⁻¹	Speed rating n_{gr} min ⁻¹	Factor f_0	Mass m ≈ kg	Designation ▶ 225 1.12 ▶ 226 1.13
d	D	B	dyn. C_r N	stat. C_{0r} N						
2	5	2,3	180	49,5	1,26	137 000	114 000	12,9	0,001	682-2Z
	6	3	350	99	2,6	112 000	107 000	11,5	0,002	692-2Z
	7	3,5	410	128	7,3	102 000	89 000	12,7	0,001	602-2Z
3	7	3	330	112	2,9	103 000	79 000	14	0,001	683-2Z
	8	4	590	180	4,65	87 000	83 000	11,9	0,001	693-2Z
	10	4	670	218	11,1	84 000	80 000	12,3	0,002	623-2Z
4	9	4	680	225	5,8	81 000	71 000	12,7	0,002	684-2Z
	12	4	1 020	345	19,7	69 000	59 000	12,3	0,002	604-2Z
	13	5	1 380	485	24,6	61 000	53 000	12,2	0,003	624-2Z
	16	5	1 840	670	40,5	53 000	42 000	12,4	0,006	634-2Z
5	11	5	760	280	7,3	71 000	61 000	–	0,002	685-2Z
	14	5	1 410	510	29	58 000	49 000	12,9	0,004	605-2Z
	16	5	1 560	600	28,5	55 000	43 500	13,2	0,005	625-2Z
	19	6	2 600	1 050	53	45 000	34 000	13	0,009	635-2Z
6	13	5	1 150	440	11,4	61 000	49 000	13,8	0,003	686-2Z
	17	6	2 090	740	42	49 000	43 500	12,2	0,006	606-2Z
	19	6	2 600	1 050	53	45 000	35 000	13	0,008	626-2Z
7	14	5	1 250	510	13,2	58 000	43 500	14,2	0,003	687-2Z
	19	6	2 800	1 060	65	44 500	37 500	12,4	0,008	607-2Z
	22	7	3 500	1 360	69	40 500	35 000	12,3	0,014	627-2Z
8	16	5	1 330	590	15,2	53 000	37 000	14,8	0,004	688-2Z
	22	7	3 500	1 370	69	40 000	34 500	12,4	0,012	608-2Z
	24	8	3 550	1 410	89	38 500	34 500	12,8	0,018	628-2Z
9	17	5	1 410	660	17,1	51 000	33 500	15	0,005	689-2Z
	24	7	3 900	1 640	83	38 000	30 000	13	0,016	609-2Z
	26	8	5 000	1 970	133	44 500	29 500	12,4	0,019	629-C
	26	8	5 000	1 970	133	38 000	29 500	12,4	0,02	629-C-2BRS
	26	8	5 000	1 970	133	30 000	–	12,4	0,02	629-C-2HRS
	26	8	5 000	1 970	133	38 000	29 500	12,4	0,02	629-C-2Z

medias ▶ <https://www.schaeffler.de/std/1E28>

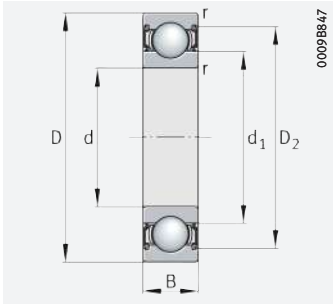

With seal 2Z

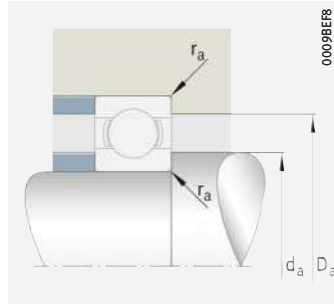

Mounting dimensions



Dimensions						Mounting dimensions		
d	r	D ₁	D ₂	d ₁	d ₂	d _a	D _a	r _a
	min.	≈	≈	≈		min.	max.	max.
2	0,08	–	4,4	2,7	–	2,52	4,48	0,08
	0,15	–	5,4	3	–	2,8	5,2	0,15
	0,15	–	6,2	–	3,2	2,8	6,2	0,15
3	0,1	–	6,4	–	3,9	3,6	6,4	0,1
	0,15	–	7,3	4,4	–	3,8	7,2	0,15
	0,15	–	8,3	–	4,7	4,4	8,6	0,2
4	0,1	–	8,1	5,2	–	4,6	8,77	0,1
	0,2	–	9,9	–	5,6	5,4	10,6	0,2
	0,2	–	11,4	–	6,3	5,8	11,2	0,2
	0,3	–	13,5	–	7,5	6,4	13,6	0,3
5	0,15	–	9,9	–	6,2	5,8	10,2	0,15
	0,2	–	12,2	–	6,9	6,4	12,6	0,2
	0,3	–	13,5	–	7,5	7,4	13,6	0,3
	0,3	–	16,7	–	9	7,4	16,6	0,3
6	0,15	–	11,8	7,9	–	6,8	12,2	0,15
	0,3	–	14,7	9	–	8	15	0,3
	0,3	–	16,7	–	9	8,4	16,6	0,3
7	0,15	–	12,7	–	8,5	7,8	13,2	0,15
	0,3	–	16,7	–	9,4	9	17	0,3
	0,3	–	19,3	–	11	9,4	19,6	0,3
8	0,2	–	14,2	–	9,7	9,4	14,6	0,2
	0,3	–	19,3	–	11	10	20	0,3
	0,3	–	20,1	–	12,7	10,4	21,6	0,3
9	0,2	–	15,2	–	10,7	10,4	15,6	0,2
	0,3	–	20,1	–	12,2	11	22	0,3
	0,3	–	23,3	–	13,6	11,4	23,6	0,3
	0,3	–	23,4	–	13,4	11,4	23,6	0,3
	0,3	–	21,4	–	13,6	11,4	23,6	0,3
	0,3	–	21,4	–	13,6	11,4	23,6	0,3



Deep groove ball bearings

Single row

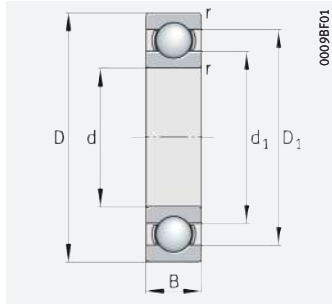

Open

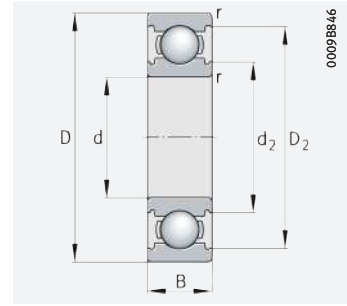

Generation C, open

d = 10 – 10 mm

Main dimensions			Basic load ratings		Fatigue limit load C_{ur} N	Limiting speed n_G min^{-1}	Speed rating $n_{\theta r}$ min^{-1}	Factor f_0	Mass m \approx kg	Designation ▶ 225 1.12 ▶ 226 1.13
d	D	B	dyn. C_r N	stat. C_{0r} N						
10	19	5	1 820	840	56	54 000	27 500	14,8	0,005	61800
	19	5	1 820	840	56	21 100	–	14,8	0,006	61800-2RSR
	19	5	1 820	840	56	46 000	27 500	14,8	0,006	61800-2Z
	22	6	2 850	1 270	65	48 000	27 000	14	0,01	61900
	22	6	2 850	1 270	65	19 200	–	14	0,012	61900-2RSR
	22	6	2 850	1 270	65	41 000	27 000	14	0,01	61900-2Z
	26	8	5 000	1 970	133	44 500	30 000	12,4	0,017	6000-C
	26	8	5 000	1 970	133	38 000	30 000	12,4	0,02	6000-C-2BRS
	26	8	5 000	1 970	133	30 000	–	12,4	0,018	6000-C-2HRS
	26	8	5 000	1 970	133	38 000	30 000	12,4	0,02	6000-C-2Z
	30	9	6 600	2 600	177	40 500	26 000	12	0,03	6200-C
	30	9	6 600	2 600	177	34 500	26 000	12	0,033	6200-C-2BRS
	30	9	6 600	2 600	177	27 000	–	12	0,032	6200-C-2HRS
	30	9	6 600	2 600	177	34 500	26 000	12	0,032	6200-C-2Z
	30	14	6 200	2 600	194	16 700	–	12	0,044	62200-2RSR
	35	11	8 600	3 450	174	31 000	21 100	11,3	0,055	6300
	35	11	8 600	3 450	174	9 500	–	11,3	0,057	6300-2RSR
35	11	8 600	3 450	174	26 500	21 100	11,3	0,057	6300-2Z	
35	17	8 500	3 450	265	14 900	–	11,3	0,06	62300-2RSR	

medias ▶ <https://www.schaeffler.de/std/1E29>

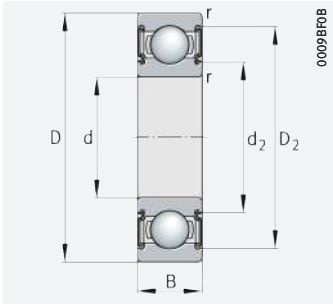

With seal 2BRS, 2HRS, 2RSR, 2Z

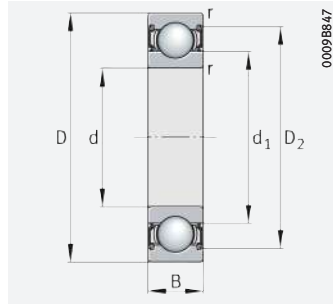

With seal 2RSR

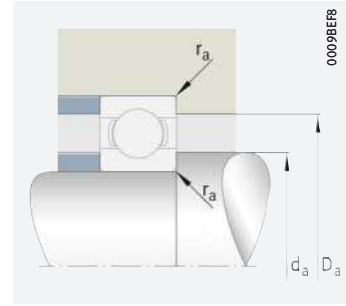

Mounting dimensions



Dimensions

d	r	D ₁	D ₂	d ₁	d ₂
	min.	≈	≈	≈	
10	0,3	16,3	–	12,7	–
	0,3	–	17,2	–	11,8
	0,3	–	17,2	–	11,8
	0,3	18,2	–	13,9	–
	0,3	–	19,4	–	13,2
	0,3	–	19,4	–	13,2
	0,3	–	23,3	–	13,6
	0,3	–	23,4	–	13,4
	0,3	–	23,4	–	13,4
	0,3	–	23,4	–	13,6
	0,6	–	25,8	–	14,9
	0,6	–	26	–	14,9
	0,6	–	25	–	15
	0,6	–	26	–	14,9
	0,6	–	25,8	16	–
	0,6	27	–	18,1	–
	0,6	–	28,6	18,1	–
	0,6	–	28,6	18,1	–
0,6	–	29,5	–	15,4	

Mounting dimensions

d _a	D _a	r _a
min.	max.	max.
12	17	0,3
12	17	0,3
12	17	0,3
12	20	0,3
12	20	0,3
12	20	0,3
12	24	0,3
12	24	0,3
12	24	0,3
12	24	0,3
12	24	0,3
14,2	25,8	0,6
14,2	26	0,6
14,2	25,8	0,6
14,2	25,8	0,6
14,2	25,8	0,6
14,2	30,8	0,6
14,2	30,8	0,6
14,2	30,8	0,6
14,2	30,8	0,6



Deep groove ball bearings

Single row

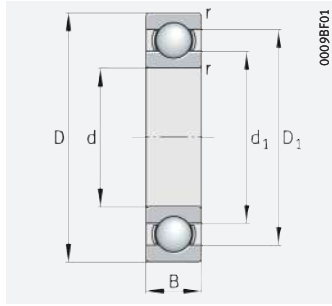

Open

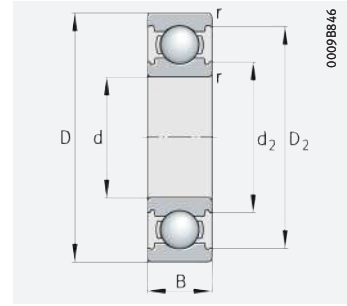

Generation C, open

d = 12 – 12 mm

Main dimensions			Basic load ratings		Fatigue limit load C_{ur} N	Limiting speed n_G min ⁻¹	Speed rating $n_{\theta r}$ min ⁻¹	Factor f_0	Mass m ≈ kg	Designation ▶ 225 1.12 ▶ 226 1.13
d	D	B	dyn. C_r N	stat. C_{0r} N						
12	21	5	1890	910	46	42 500	23 500	13,4	0,007	61801
	21	5	1890	910	46	18 100	–	13,4	0,007	61801-2RSR
	21	5	1890	910	46	42 500	23 500	13,4	0,006	61801-2Z
	24	6	3 050	1 460	75	45 000	23 300	14,5	0,012	61901
	24	6	3 050	1 460	75	16 700	–	14,5	0,012	61901-2RSR
	24	6	3 050	1 460	75	38 000	23 300	14,5	0,012	61901-2Z
	28	8	5 500	2 370	158	42 500	26 000	13,1	0,02	6001-C
	28	8	5 500	2 370	158	36 000	26 000	13,1	0,02	6001-C-2BRS
	28	8	5 500	2 370	158	26 000	–	13,1	0,02	6001-C-2HRS
	28	8	5 500	2 370	158	36 000	26 000	13,1	0,02	6001-C-2Z
	32	10	7 600	3 100	208	37 000	24 600	12,3	0,037	6201-C
	32	10	7 600	3 100	208	31 500	24 600	12,3	0,039	6201-C-2BRS
	32	10	7 600	3 100	208	23 400	–	12,3	0,039	6201-C-2HRS
	32	10	7 600	3 100	208	31 500	24 600	12,3	0,039	6201-C-2Z
	32	14	7 200	3 100	236	14 600	–	12,3	0,049	62201-2RSR
	37	17	10 300	4 200	320	13 900	–	11,1	0,07	62301-2RSR
	37	12	10 900	4 200	280	31 000	21 900	11,1	0,062	6301-C
	37	12	10 900	4 200	280	26 500	21 900	11,1	0,064	6301-C-2BRS
37	12	10 900	4 200	280	21 700	–	11,1	0,064	6301-C-2HRS	
37	12	10 900	4 200	280	26 500	21 900	11,1	0,061	6301-C-2Z	

medias ▶ <https://www.schaeffler.de/std/1E2A>

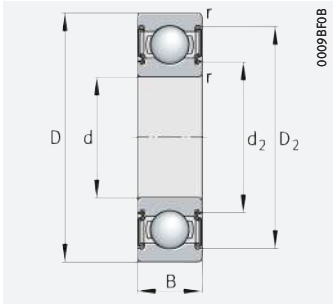

With seal 2BRS, 2HRS, 2RSR, 2Z

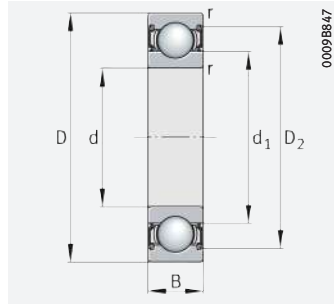

With seal 2RSR

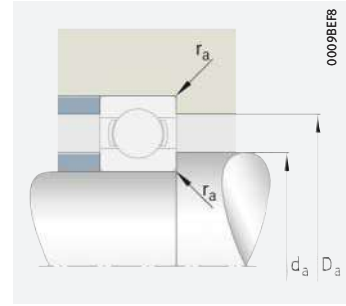

Mounting dimensions



Dimensions

d	r	D ₁	D ₂	d ₁	d ₂
	min.	≈	≈	≈	
12	0,3	18,3	–	14,8	–
	0,3	–	19,2	–	13,8
	0,3	–	19,2	–	13,8
	0,3	20,3	–	16	–
	0,3	–	21,4	–	15,4
	0,3	–	21,4	–	15,4
	0,3	–	25,3	–	15,6
	0,3	–	25,4	–	15,4
	0,3	–	24,5	–	15,6
	0,3	–	25,3	–	15,6
	0,6	–	28	–	17,2
	0,6	–	28,2	–	17
	0,6	–	27,4	–	17,2
	0,6	–	28,2	–	17,2
	0,6	–	27,9	18,3	–
	1	–	32,6	19,3	–
	1	–	32	–	18
	1	–	32	–	17,9
	1	–	32	–	18
	1	–	32	–	18

Mounting dimensions

d _a	D _a	r _a
min.	max.	max.
14	19	0,3
14	19	0,3
14	19	0,3
14	22	0,3
14	22	0,3
14	22	0,3
14	26	0,3
14	26	0,3
14	26	0,3
14	26	0,3
14	26	0,3
16,2	27,8	0,6
16,2	27,8	0,6
16,2	27,8	0,6
16,2	27,8	0,6
16,2	27,8	0,6
18,75	30,55	1
17,6	31,4	1
17,6	31,4	1
17,6	31,4	1
17,6	31,4	1



Deep groove ball bearings

Single row

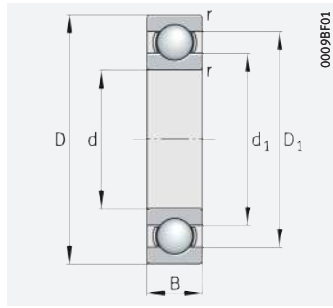

Open

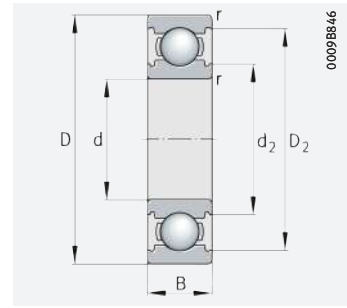

Generation C, open

d = 15 – 15 mm

Main dimensions			Basic load ratings		Fatigue limit load C_{ur} N	Limiting speed n_G min^{-1}	Speed rating $n_{\theta r}$ min^{-1}	Factor f_0	Mass m $\approx \text{kg}$	Designation ▶ 225 1.12 ▶ 226 1.13
d	D	B	dyn. C_r N	stat. C_{0r} N						
15	24	5	2 050	1 100	56	45 000	19 200	13,9	0,008	61802
	24	5	2 050	1 100	56	15 000	–	13,9	0,008	61802-2RSR
	24	5	2 050	1 100	56	38 000	19 200	13,9	0,008	61802-2Z
	28	7	4 600	2 260	128	38 000	20 600	14,3	0,019	61902
	28	7	4 600	2 260	128	14 200	–	14,3	0,019	61902-2RSR
	28	7	4 600	2 260	128	32 000	20 600	14,3	0,019	61902-2Z
	32	8	5 900	2 850	144	33 500	20 000	14	0,025	16002
	32	9	6 000	2 850	171	37 000	23 200	14	0,031	6002-C
	32	9	6 000	2 850	171	31 500	23 200	14	0,033	6002-C-2BRS
	32	9	6 000	2 850	171	21 000	–	14	0,028	6002-C-2HRS
	32	9	6 000	2 850	171	31 500	23 200	14	0,033	6002-C-2Z
	35	11	8 400	3 750	250	33 000	21 900	13	0,043	6202-C
	35	11	8 400	3 750	250	28 000	22 000	13	0,033	6202-C-2BRS
	35	11	8 400	3 750	250	20 000	–	13	0,045	6202-C-2HRS
	35	11	8 400	3 750	250	28 000	21 900	13	0,045	6202-C-2Z
	35	14	8 200	3 750	191	12 700	–	13	0,057	62202-2RSR
	42	17	11 900	5 300	410	11 500	–	12	0,106	62302-2RSR
	42	13	12 600	5 300	360	27 500	19 200	12	0,08	6302-C
42	13	12 600	5 300	360	23 500	19 200	12	0,083	6302-C-2BRS	
42	13	12 600	5 300	360	17 700	–	12	0,083	6302-C-2HRS	
42	13	12 600	5 300	360	23 500	19 200	12	0,082	6302-C-2Z	

medias ▶ <https://www.schaeffler.de/std/1E2B>

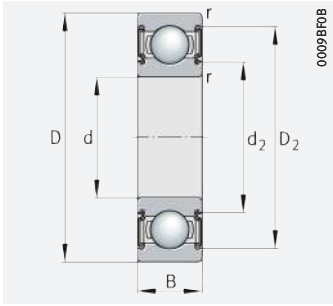

With seal 2BRS, 2HRS, 2RSR, 2Z

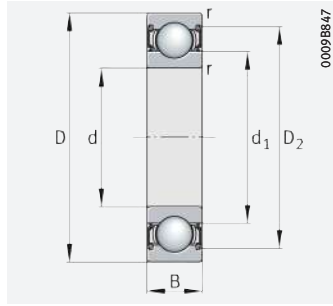

With seal 2RSR, 2Z

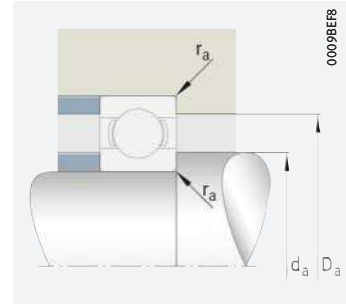

Mounting dimensions



Dimensions						Mounting dimensions			
d	r	D ₁	D ₂	d ₁	d ₂	d _a	D _a	r _a	
	min.	≈	≈	≈		min.	max.	max.	
15	0,3	21,3	–	17,8	–	17	22	0,3	
	0,3	–	22,2	–	16,8	17	22	0,3	
	0,3	–	22,2	–	16,8	17	22	0,3	
	0,3	24,2	–	18,8	–	17	26	0,3	
	0,3	–	25,3	18,8	–	17	26	0,3	
	0,3	–	25,3	18,8	–	17	26	0,3	
	0,3	26,8	–	20,5	–	17	30	0,3	
	0,3	–	28,9	–	19,1	–	17	30	0,3
	0,3	–	29	–	18,9	–	17	30	0,3
	0,3	–	28,4	–	19,1	–	17	30	0,3
	0,3	–	28,4	–	19,1	–	17	30	0,3
	0,6	–	31,2	–	15,6	–	19,2	30,8	0,6
	0,6	–	29	–	18,9	–	19,2	30,8	0,6
	0,6	–	29	–	20	–	19,2	30,8	0,6
	0,6	–	31,2	–	20	–	19,2	30,8	0,6
	0,6	–	30,6	21,1	–	–	19,2	30,8	0,6
	1	–	36,2	–	23,2	–	20,6	36,4	1
	1	–	34,1	–	22,9	–	20,6	36,4	1
1	–	34,1	–	22,9	–	20,6	36,4	1	
1	–	34,1	–	22,9	–	20,6	36,4	1	
1	–	34,1	–	22,9	–	20,6	36,4	1	



Deep groove ball bearings

Single row

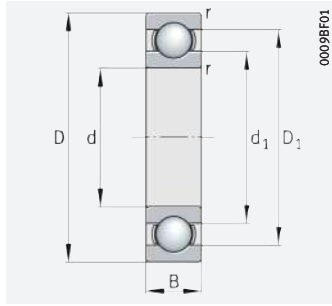

Open

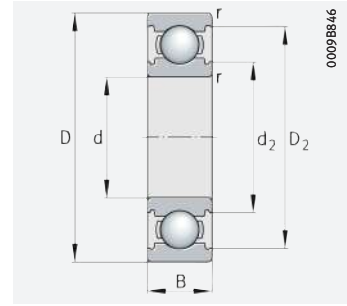

Generation C, open

d = 17 – 17 mm

Main dimensions			Basic load ratings		Fatigue limit load C_{ur} N	Limiting speed n_G min^{-1}	Speed rating $n_{\theta r}$ min^{-1}	Factor f_0	Mass m $\approx \text{kg}$	Designation ▶ 225 1.12 ▶ 226 1.13
d	D	B	dyn. C_r N	stat. C_{0r} N						
17	26	5	2 210	1 280	65	41 500	17 100	14,1	0,008	61803
	26	5	2 210	1 280	65	13 500	–	14,1	0,008	61803-2RSR
	26	5	2 210	1 280	65	35 000	17 100	14,1	0,008	61803-2Z
	30	7	4 900	2 550	146	34 500	17 800	14,7	0,014	61903
	30	7	4 900	2 550	146	12 700	–	14,7	0,02	61903-2RSR
	30	7	4 900	2 550	146	29 000	17 800	14,7	0,017	61903-2Z
	35	10	6 400	3 250	157	31 000	20 300	14,3	0,038	6003
	35	8	6 400	3 250	165	31 000	17 700	14,3	0,032	16003
	35	10	6 400	3 250	157	11 800	–	14,3	0,04	6003-2RSR
	35	10	6 400	3 250	157	26 000	20 300	14,3	0,04	6003-2Z
	40	12	10 400	4 750	320	29 000	20 100	13	0,062	6203-C
	40	12	10 400	4 750	320	24 600	20 100	13	0,065	6203-C-2BRS
	40	12	10 400	4 750	320	17 600	–	13	0,067	6203-C-2HRS
	40	12	10 400	4 750	320	24 600	20 100	13	0,067	6203-C-2Z
	40	16	10 000	4 750	345	11 100	–	13	0,085	62203-2RSR
	47	19	14 300	6 600	510	9 700	–	12,4	0,152	62303-2RSR
	47	14	15 000	6 500	440	24 500	17 400	12,2	0,107	6303-C
	47	14	15 000	6 500	440	20 800	17 400	12,2	0,111	6303-C-2BRS
47	14	15 000	6 500	440	15 700	–	12,2	0,111	6303-C-2HRS	
47	14	15 000	6 500	440	20 800	17 400	12,2	0,067	6303-C-2Z	
62	17	23 800	11 500	750	16 200	11 600	12,4	0,269	6403	

medias ▶ <https://www.schaeffler.de/std/1E2C>

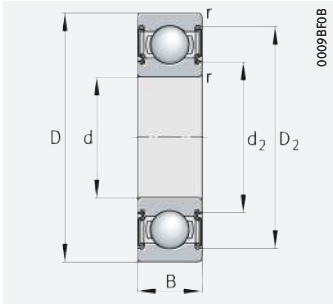

With seal 2BRS, 2HRS, 2RSR, 2Z

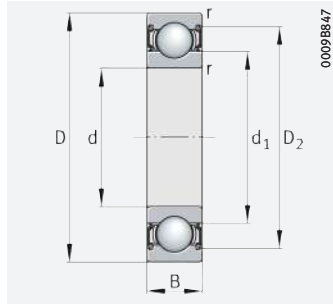

With seal 2RSR, 2Z

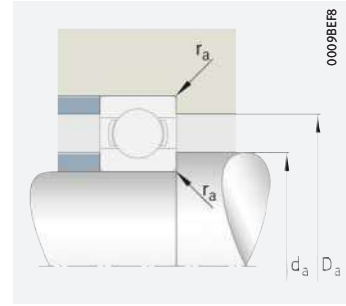

Mounting dimensions



Dimensions

d	r	D ₁	D ₂	d ₁	d ₂
	min.	≈	≈	≈	
17	0,3	23,3	–	19,8	–
	0,3	–	24,2	–	18,8
	0,3	–	24,2	–	18,8
	0,3	26,8	–	21	–
	0,3	–	27,8	21	–
	0,3	–	27,8	21	–
	0,3	29,5	–	22,7	–
	0,3	29,5	–	22,8	–
	0,3	–	30,8	22,7	–
	0,3	–	30,8	22,7	–
	0,6	–	35	–	22,8
	0,6	–	35,2	–	22,8
	0,6	–	34,4	–	22,8
	0,6	–	32,9	–	22,8
	0,6	–	35	24,1	–
	1	–	41,1	27,5	–
	1	–	40,2	–	25,9
	1	–	40,2	–	25,9
1	–	40,2	–	25,9	
1	–	35,2	–	22,6	
1,1	50,2	–	36,4	–	

Mounting dimensions

d _a	D _a	r _a
min.	max.	max.
19	24	0,3
19	24	0,3
19	24	0,3
19	28	0,3
19	28	0,3
19	28	0,3
19	33	0,3
19	33	0,3
19	33	0,3
19	33	0,3
21,2	35,8	0,6
21,2	35,8	0,6
21,2	35,8	0,6
21,2	35,8	0,6
21,2	35,8	0,6
22,6	41,4	1
22,6	41,4	1
22,6	41,4	1
22,6	41,4	1
22,6	41,4	1
26	53	1



Deep groove ball bearings

Single row

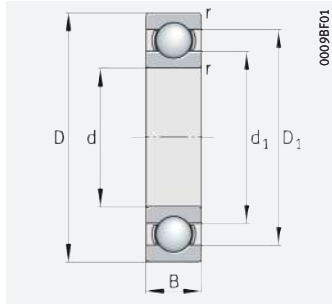

Open

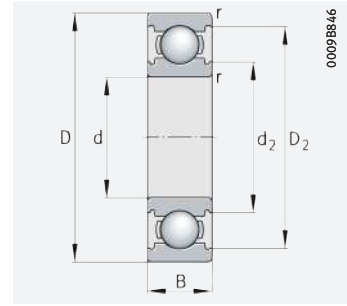

Generation C, open

d = 20 – 20 mm

Main dimensions			Basic load ratings		Fatigue limit load C_{ur} N	Limiting speed n_G min^{-1}	Speed rating $n_{\theta r}$ min^{-1}	Factor f_0	Mass m $\approx \text{kg}$	Designation ▶ 225 1.12 ▶ 226 1.13
d	D	B	dyn. C_r N	stat. C_{0r} N						
20	32	7	3 950	2 130	108	33 500	17 200	13,4	0,018	61804
	32	7	3 950	2 130	108	11 500	–	13,4	0,018	61804-2RSR
	32	7	3 950	2 130	108	28 500	17 200	13,4	0,018	61804-2Z
	37	9	6 800	3 700	226	28 500	17 000	14,8	0,04	61904
	37	9	6 800	3 700	226	10 600	–	14,8	0,037	61904-2RSR
	37	9	6 800	3 700	226	24 200	17 000	14,8	0,037	61904-2Z
	42	8	7 400	4 100	207	26 000	14 300	14,9	0,048	16004
	42	12	10 000	5 000	305	27 500	19 700	13,8	0,07	6004-C
	42	12	10 000	5 000	305	23 200	19 700	13,8	0,071	6004-C-2BRS
	42	12	10 000	5 000	305	15 800	–	13,8	0,069	6004-C-2HRS
	42	12	10 000	5 000	305	23 200	19 700	13,8	0,066	6004-C-2Z
	47	14	13 900	6 600	445	24 300	18 100	13,1	0,106	6204-C
	47	14	13 900	6 600	445	20 600	18 100	13,1	0,104	6204-C-2BRS
	47	14	13 900	6 600	445	15 000	–	13,1	0,11	6204-C-2HRS
	47	14	13 900	6 600	445	20 600	18 100	13,1	0,104	6204-C-2Z
	47	18	13 400	6 600	475	9 400	–	13,1	0,129	62204-2RSR
	52	15	16 900	7 900	530	19 800	14 400	12,4	0,151	6304
	52	21	16 900	7 900	540	8 900	–	12,4	0,2	62304-2RSR
	52	15	16 900	7 900	530	8 800	–	12,4	0,155	6304-2RSR
52	15	16 900	7 900	530	16 800	14 400	12,4	0,155	6304-2Z	
72	19	30 500	16 200	820	13 700	9 800	13	0,405	6404	

medias ▶ <https://www.schaeffler.de/std/1E2D>

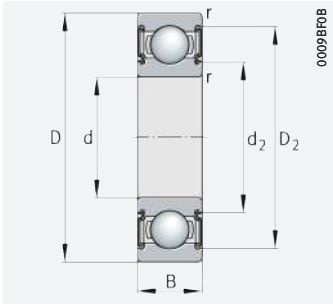

With seal 2BRS, 2HRS, 2RSR, 2Z

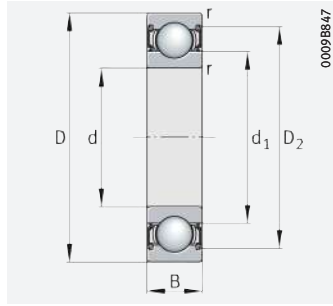

With seal 2RSR, 2Z

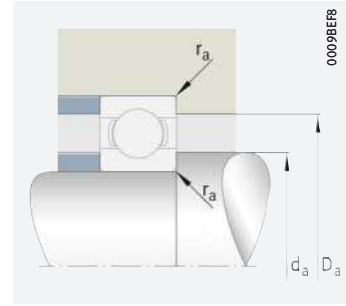

Mounting dimensions



Dimensions						Mounting dimensions		
d	r	D ₁	D ₂	d ₁	d ₂	d _a	D _a	r _a
	min.	≈	≈	≈		min.	max.	max.
20	0,3	28,2	–	23,2	–	22	30	0,3
	0,3	–	29,5	–	22,6	22	30	0,3
	0,3	–	29,5	–	22,6	22	30	0,3
	0,3	32	–	25,2	–	22	35	0,3
	0,3	–	33,5	–	23,7	22	35	0,3
	0,3	–	33,5	–	23,7	22	35	0,3
	0,3	35	–	28,4	–	22	40	0,3
	0,6	–	37,4	–	25,2	23,2	38,8	0,6
	0,6	–	37,7	–	25,1	23,2	38,8	0,6
	0,6	–	37,4	–	25,2	23,2	38,8	0,6
	0,6	–	37,4	–	25,2	23,2	38,8	0,6
	1	–	41,4	–	26,5	25,6	41,4	1
	1	–	41,4	–	26,6	25,6	41,4	1
	1	–	41,4	–	26,6	25,6	41,4	1
	1	–	41,4	–	26,6	25,6	41,4	1
	1	–	41,5	–	25,9	25,6	41,4	1
	1,1	41,9	–	30,3	–	27	45	1
	1,1	–	45,1	30	–	27	45	1
	1,1	–	44,4	30,3	–	27	45	1
	1,1	–	44,4	30,3	–	27	45	1
1,1	59,6	–	37,5	–	29	63	1	



Deep groove ball bearings

Single row

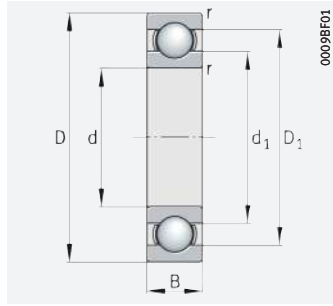

Open

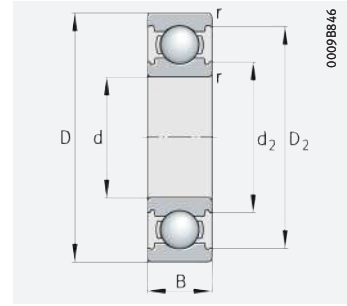

Generation C, open

d = 25 – 25 mm

Main dimensions			Basic load ratings		Fatigue limit load C_{ur} N	Limiting speed n_G min^{-1}	Speed rating $n_{\theta r}$ min^{-1}	Factor f_0	Mass m $\approx \text{kg}$	Designation ▶ 225 1.12 ▶ 226 1.13
d	D	B	dyn. C_r N	stat. C_{0r} N						
25	37	7	4 250	2 550	129	28 000	13 900	13,9	0,023	61805
	37	7	4 250	2 550	129	9 500	–	13,9	0,021	61805-2RSR
	37	7	4 250	2 550	129	24 000	13 900	13,9	0,02	61805-2Z
	42	9	7 400	4 550	280	24 200	13 500	15,4	0,042	61905
	42	9	7 400	4 550	280	8 700	–	15,4	0,047	61905-2RSR
	42	9	7 400	4 550	280	20 500	13 500	15,4	0,045	61905-2Z
	47	12	10 700	5 900	305	21 900	15 200	14,6	0,081	6005
	47	8	7 700	4 650	234	22 900	12 000	15,5	0,052	16005
	47	12	10 700	5 900	305	8 400	–	14,6	0,085	6005-2RSR
	47	12	10 700	5 900	305	18 600	15 200	14,6	0,083	6005-2Z
	52	15	15 000	7 800	485	21 600	16 000	13,8	0,129	6205-C
	52	15	15 000	7 800	485	18 400	16 000	13,8	0,133	6205-C-2BRS
	52	15	15 000	7 800	485	12 700	–	13,8	0,133	6205-C-2HRS
	52	15	15 000	7 800	485	18 400	16 000	13,8	0,133	6205-C-2Z
	52	18	14 900	7 900	530	7 900	–	13,9	0,155	62205-2RSR
	62	24	23 800	11 500	770	7 300	–	12,4	0,316	62305-2RSR
	62	17	24 700	11 500	780	17 800	13 500	12,4	0,215	6305-C
	62	17	24 700	11 500	780	15 100	13 500	12,4	0,242	6305-C-2BRS
	62	17	24 700	11 500	780	11 300	–	12,4	0,224	6305-C-2HRS
62	17	24 700	11 500	780	15 100	13 500	12,4	0,222	6305-C-2Z	
80	21	35 500	19 100	1 250	12 300	9 400	13,1	0,549	6405	

medias ▶ <https://www.schaeffler.de/std/1E2E>

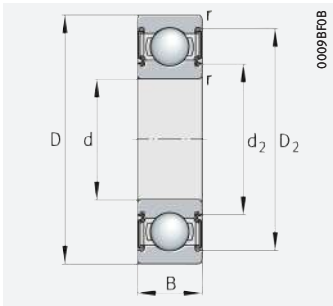

With seal 2BRS, 2HRS, 2RSR, 2Z

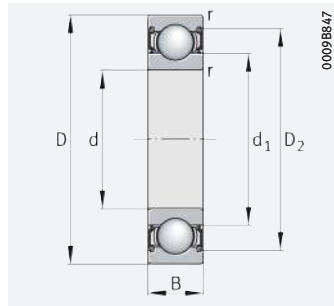

With seal 2RSR, 2Z

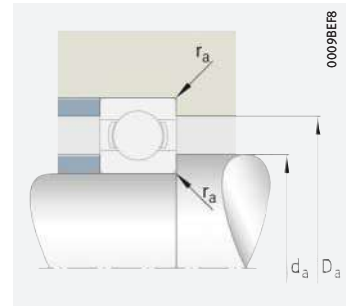

Mounting dimensions



Dimensions						Mounting dimensions		
d	r	D ₁	D ₂	d ₁	d ₂	d _a	D _a	r _a
	min.	≈	≈	≈		min.	max.	max.
25	0,3	33,2	–	28,2	–	27	35	0,3
	0,3	–	34,2	28,2	–	27	35	0,3
	0,3	–	34,2	28,2	–	27	35	0,3
	0,3	37,5	–	30,9	–	27	40	0,3
	0,3	–	39,5	30,9	–	27	40	0,3
	0,3	–	39,5	30,9	–	27	40	0,3
	0,6	40,2	–	32	–	28,2	43,8	0,6
	0,3	40	–	32,5	–	27	45	0,3
	0,6	–	42,5	32	–	28,2	43,8	0,6
	0,6	–	42,5	32	–	28,2	43,8	0,6
	1	–	46,4	–	31,4	30,6	46,4	1
	1	–	46,4	–	31,3	30,6	46,4	1
	1	–	46,4	–	31,4	30,6	46,4	1
	1	–	46,4	–	31,4	30,6	46,4	1
	1	–	46,3	–	31,8	30,6	46,4	1
	1,1	–	52,8	–	33,6	32	55	1
	1,1	–	54	–	34	32	55	1
	1,1	–	54	–	34	32	55	1
	1,1	–	54	–	34	32	55	1
	1,1	–	54	–	34	32	55	1
1,5	65,6	–	49,3	–	36	69	1,5	



Deep groove ball bearings

Single row

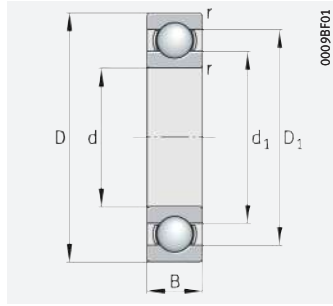

Open

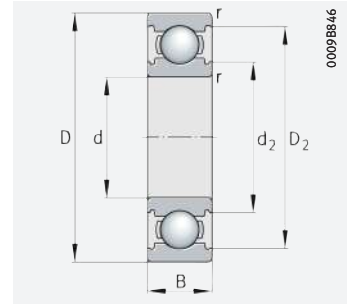

Generation C, open

d = 30 – 30 mm

Main dimensions			Basic load ratings		Fatigue limit load C_{ur} N	Limiting speed n_G min^{-1}	Speed rating $n_{\theta r}$ min^{-1}	Factor f_0	Mass m $\approx \text{kg}$	Designation ▶ 225 1.12 ▶ 226 1.13
d	D	B	dyn. C_r N	stat. C_{0r} N						
30	42	7	4 500	2 950	149	24 500	11 500	14,2	0,027	61806
	42	7	4 500	2 950	149	8 100	–	14,2	0,027	61806-2RSR
	42	7	4 500	2 950	149	20 800	11 500	14,2	0,027	61806-2Z
	47	9	7 700	5 000	310	21 700	11 900	15,7	0,051	61906
	47	9	7 700	5 000	310	7 600	–	15,7	0,053	61906-2RSR
	47	9	7 700	5 000	310	18 400	11 900	15,7	0,053	61906-2Z
	55	13	13 500	8 000	390	18 500	13 100	14,8	0,122	6006
	55	9	11 900	7 300	370	18 900	10 500	15,1	0,082	16006
	55	13	13 500	8 000	390	7 000	–	14,8	0,126	6006-2RSR
	55	13	13 500	8 000	390	15 700	13 100	14,8	0,126	6006-2Z
	62	16	20 800	11 300	700	17 800	13 400	13,8	0,195	6206-C
	62	16	20 800	11 300	700	15 100	13 400	13,8	0,201	6206-C-2BRS
	62	16	20 800	11 300	700	10 600	–	13,8	0,201	6206-C-2HRS
	62	16	20 800	11 300	700	15 100	13 400	13,8	0,201	6206-C-2Z
	62	20	20 700	11 300	570	6 700	–	13,8	0,243	62206-2RSR
	72	27	30 000	15 800	1 060	6 000	–	13	0,486	62306-2RSR
	72	19	32 000	16 200	1 090	15 100	11 500	13	0,328	6306-C
	72	19	32 000	16 200	1 090	12 800	11 500	13	0,339	6306-C-2BRS
	72	19	32 000	16 200	1 090	8 900	–	13	0,34	6306-C-2HRS
72	19	32 000	16 200	1 090	12 800	11 500	13	0,339	6306-C-2Z	
90	23	45 500	25 000	1 640	10 800	8 600	13	0,74	6406	

medias ▶ <https://www.schaeffler.de/std/1E2F>

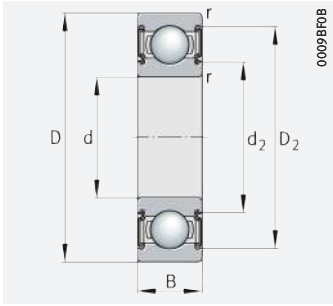

With seal 2BRS, 2HRS, 2RSR, 2Z

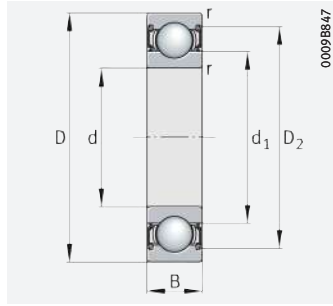

With seal 2RSR, 2Z

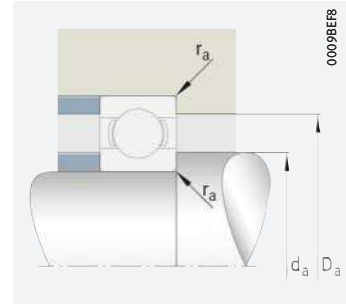

Mounting dimensions



Dimensions						Mounting dimensions		
d	r	D ₁	D ₂	d ₁	d ₂	d _a	D _a	r _a
	min.	≈	≈	≈		min.	max.	max.
30	0,3	38,2	–	33,1	–	32	40	0,3
	0,3	–	39,2	33,1	–	32	40	0,3
	0,3	–	39,2	33,1	–	32	40	0,3
	0,3	42	–	35,1	–	32	45	0,3
	0,3	–	44,1	35,1	–	32	45	0,3
	0,3	–	44,1	35,1	–	32	45	0,3
	1	47,2	–	38,3	–	34,6	50,4	1
	0,3	47,9	–	39,2	–	32	53	0,3
	1	–	49,2	38,3	–	34,6	50,4	1
	1	–	49,2	38,3	–	34,6	50,4	1
	1	–	55,4	–	37,5	35,6	56,4	1
	1	–	55,4	–	37,4	35,6	56,4	1
	1	–	55,4	–	37,5	35,6	56,4	1
	1	–	55,4	–	37,5	35,6	56,4	1
	1	–	55,4	–	37,5	35,6	56,4	1
	1	–	55,2	–	38	35,6	56,4	1
	1,1	–	62,5	–	41,7	37	65	1
	1,1	–	63,4	–	41,3	37	65	1
	1,1	–	63,4	–	41,3	37	65	1
	1,1	–	63,4	–	41,3	37	65	1
1,1	–	63,4	–	41,3	37	65	1	
1,5	74,6	–	55,6	–	41	79	1,5	



Deep groove ball bearings

Single row

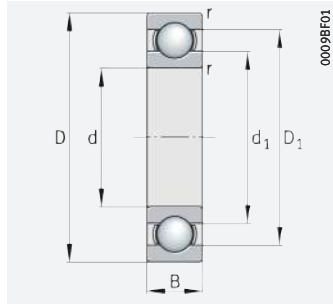

Open

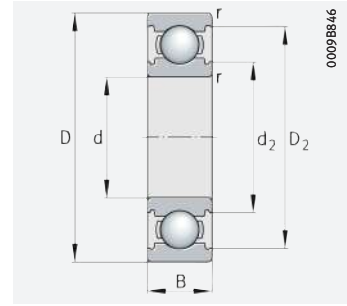

Generation C, open

d = 35 – 35 mm

Main dimensions			Basic load ratings		Fatigue limit load C_{ur} N	Limiting speed n_G min^{-1}	Speed rating $n_{\theta r}$ min^{-1}	Factor f_0	Mass m $\approx \text{kg}$	Designation ▶ 225 1.12 ▶ 226 1.13
d	D	B	dyn. C_r N	stat. C_{0r} N						
35	47	7	4 700	3 350	170	21 600	9 900	14,4	0,032	61807
	47	7	4 700	3 350	170	7 000	–	14,4	0,032	61807-2RSR
	47	7	4 700	3 350	170	18 300	9 900	14,4	0,032	61807-2Z
	55	10	10 100	6 800	410	18 300	10 500	15,7	0,076	61907
	55	10	10 100	6 800	345	6 500	–	15,7	0,076	61907-2RSR
	55	10	10 100	6 800	410	15 600	10 500	15,7	0,076	61907-2Z
	62	14	17 000	10 300	550	16 100	11 600	14,9	0,157	6007
	62	9	13 000	8 800	445	16 700	8 900	15,6	0,105	16007
	62	14	17 000	10 300	550	6 200	–	14,9	0,163	6007-2RSR
	62	14	17 000	10 300	550	13 700	11 700	14,9	0,163	6007-2Z
	72	17	28 000	15 400	1 030	15 000	11 300	13,9	0,262	6207-C
	72	17	28 000	15 400	1 030	12 700	11 300	13,9	0,274	6207-C-2BRS
	72	17	28 000	15 400	1 030	8 800	–	13,9	0,274	6207-C-2HRS
	72	17	28 000	15 400	1 030	12 700	11 300	13,9	0,273	6207-C-2Z
	72	23	27 500	15 300	770	5 700	–	13,8	0,384	62207-2RSR
	80	31	35 500	19 100	1 280	5 300	–	13,1	0,651	62307-2RSR
	80	21	37 000	19 100	1 290	13 600	10 900	13,1	0,434	6307-C
80	21	37 000	19 100	1 290	11 500	10 900	13,1	0,447	6307-C-2BRS	
80	21	37 000	19 100	1 290	8 300	–	13,1	0,449	6307-C-2HRS	
80	21	37 000	19 100	1 290	11 500	10 900	13,1	0,447	6307-C-2Z	
100	25	56 000	31 500	2 180	9 500	7 900	12,9	0,971	6407	

medias ▶ <https://www.schaeffler.de/std/1E30>

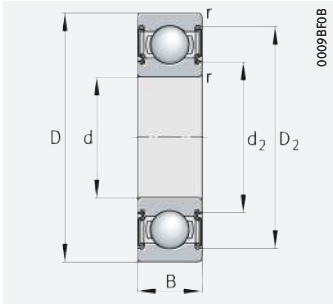

With seal 2BRS, 2HRS, 2RSR, 2Z

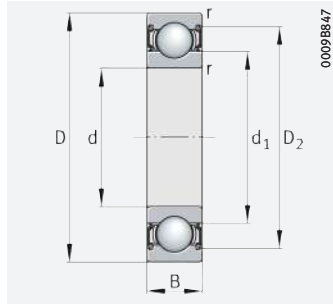

With seal 2RSR, 2Z

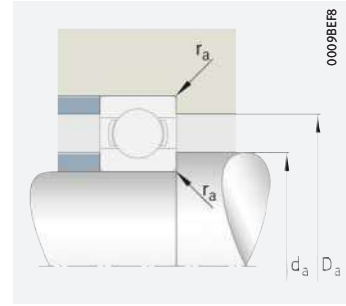

Mounting dimensions



Dimensions						Mounting dimensions		
d	r	D ₁	D ₂	d ₁	d ₂	d _a	D _a	r _a
	min.	≈	≈	≈		min.	max.	max.
35	0,3	42,8	–	38,2	–	37	45	0,3
	0,3	–	44	38,2	–	37	45	0,3
	0,3	–	44	38,2	–	37	45	0,3
	0,6	48,4	–	41,6	–	38,2	51,8	0,6
	0,6	–	50,6	41,1	–	38,2	51,8	0,6
	0,6	–	50,6	41,1	–	38,2	51,8	0,6
	1	53,3	–	43,2	–	39,6	57,4	1
	0,3	52,7	–	44,3	–	37	60	0,3
	1	–	55,4	43,2	–	39,6	57,4	1
	1	–	55,4	43,2	–	39,6	57,4	1
	1,1	–	64,7	–	44,5	42	65	1
	1,1	–	64,7	–	44,5	42	65	1
	1,1	–	64,7	–	44,5	42	65	1
	1,1	–	64,7	–	44,5	42	65	1
	1,1	–	62,9	–	44,1	42	65	1
	1,5	–	70,1	–	46,2	44	71	1,5
	1,5	–	69,8	–	46	44	71	1,5
	1,5	–	69,8	–	46	44	71	1,5
1,5	–	69,8	–	46	44	71	1,5	
1,5	–	69,8	–	46	44	71	1,5	
1,5	83,8	–	62,3	–	46	89	1,5	



Deep groove ball bearings

Single row

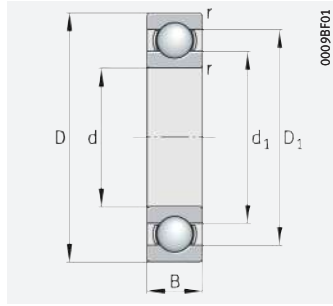

Open

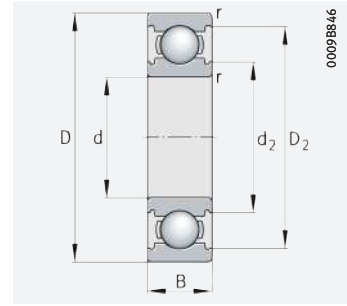

Generation C, open

d = 40 – 40 mm

Main dimensions			Basic load ratings		Fatigue limit load C_{ur} N	Limiting speed n_G min^{-1}	Speed rating $n_{\theta r}$ min^{-1}	Factor f_0	Mass m $\approx \text{kg}$	Designation ▶ 225 1.12 ▶ 226 1.13
d	D	B	dyn. C_r N	stat. C_{0r} N						
40	52	7	4 900	3 750	191	19 300	8 600	14,6	0,035	61808
	52	7	4 900	3 750	191	6 200	–	14,6	0,035	61808-2RSR
	52	7	4 900	3 750	191	16 400	8 600	14,6	0,034	61808-2Z
	62	12	14 500	9 900	580	15 800	10 000	15,5	0,117	61908
	62	12	14 500	9 900	580	5 700	–	15,5	0,11	61908-2RSR
	62	12	14 500	9 900	580	13 500	10 000	15,5	0,11	61908-2Z
	68	15	17 800	11 500	580	14 600	10 700	15,2	0,194	6008
	68	9	14 100	10 200	520	15 700	8 400	15,8	0,127	16008
	68	15	17 800	11 500	580	5 400	–	15,2	0,202	6008-2RSR
	68	15	17 800	11 500	580	12 400	10 600	15,2	0,2	6008-2Z
	80	18	31 500	17 800	1 200	13 600	10 500	14	0,345	6208-C
	80	18	31 500	17 800	1 200	11 600	10 500	14	0,359	6208-C-2BRS
	80	18	31 500	17 800	1 200	8 000	–	14	0,359	6208-C-2HRS
	80	18	31 500	17 800	1 200	11 600	10 500	14	0,359	6208-C-2Z
	80	23	31 000	17 800	1 200	5 000	–	14	0,462	62208-2RSR
	90	33	46 500	26 000	1 730	4 750	–	13	0,882	62308-2RSR
	90	23	47 000	25 000	1 690	11 800	9 900	13	0,6	6308-C
90	23	47 000	25 000	1 690	10 100	9 900	13	0,654	6308-C-2BRS	
90	23	47 000	25 000	1 690	7 400	–	13	0,622	6308-C-2HRS	
90	23	47 000	25 000	1 690	10 100	9 900	13	0,617	6308-C-2Z	
110	27	68 000	38 500	2 600	9 500	7 400	13,3	1,23	6408	

medias ▶ <https://www.schaeffler.de/std/1E31>

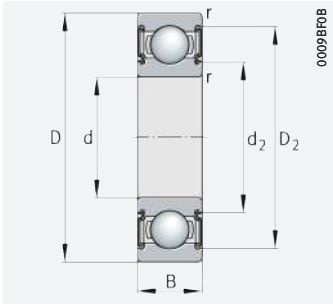

With seal 2BRS, 2HRS, 2RSR, 2Z

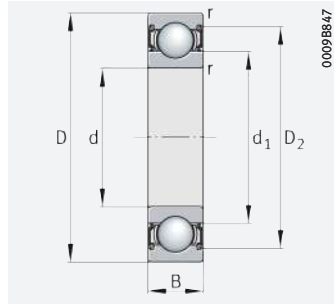

With seal 2RSR, 2Z

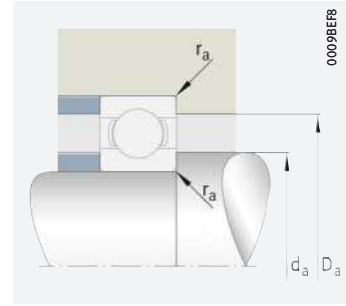

Mounting dimensions



Dimensions						Mounting dimensions		
d	r	D ₁	D ₂	d ₁	d ₂	d _a	D _a	r _a
	min.	≈	≈	≈		min.	max.	max.
40	0,3	48,1	–	43,2	–	42	50	0,3
	0,3	–	48,9	43,2	–	42	50	0,3
	0,3	–	48,9	43,2	–	42	50	0,3
	0,6	55,1	–	46,9	–	43,2	58,8	0,6
	0,6	–	57,3	46,6	–	43,2	58,8	0,6
	0,6	–	56,6	46,6	–	43,2	58,8	0,6
	1	59,1	–	49,3	–	44,6	63,4	1
	0,3	59,7	–	48,9	–	42	66	0,3
	1	–	61,6	49,3	–	44,6	63,4	1
	1	–	61,6	49,3	–	44,6	63,4	1
	1,1	–	70,7	–	49,2	47	73	1
	1,1	–	70,7	–	49,2	47	73	1
	1,1	–	70,7	–	49,2	47	73	1
	1,1	–	70,7	–	49,2	47	73	1
	1,1	–	70,6	–	50,4	47	73	1
	1,5	–	78	–	51	49	81	1,5
	1,5	–	78,8	–	52,1	49	81	1,5
	1,5	–	78,8	–	52,1	49	81	1,5
	1,5	–	78,8	–	52,1	49	81	1,5
	1,5	–	78,8	–	52,1	49	81	1,5
2	91,8	–	68	–	53	97	2	



Deep groove ball bearings

Single row

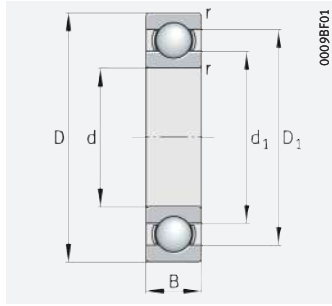

Open

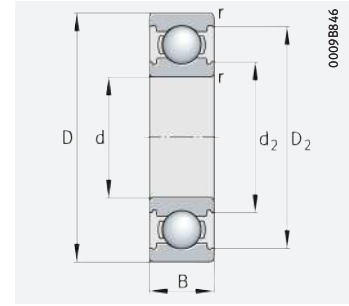

Generation C, open

d = 45 – 45 mm

Main dimensions			Basic load ratings		Fatigue limit load C_{ur} N	Limiting speed n_G min^{-1}	Speed rating $n_{\partial r}$ min^{-1}	Factor f_0	Mass m $\approx \text{kg}$	Designation ► 225 1.12 ► 226 1.13
d	D	B	dyn. C_r N	stat. C_{0r} N						
45	58	7	7 000	5 900	385	5 400	–	16,3	0,039	61809-2RSR-Y
	58	7	7 000	5 900	385	14 300	7 300	16,3	0,039	61809-2RZ-Y
	58	7	7 000	5 900	385	21 900	7 300	16,3	0,039	61809-Y
	68	12	15 000	10 900	630	14 400	8 800	16	0,135	61909
	68	12	15 000	10 900	630	5 100	–	16	0,13	61909-2RSR
	68	12	15 000	10 900	630	12 200	8 800	16	0,13	61909-2RZ
	75	16	21 200	14 400	730	13 100	9 700	15,3	0,247	6009
	75	10	16 500	12 300	700	13 100	6 900	16,1	0,16	16009
	75	16	21 200	14 400	730	4 950	–	15,3	0,257	6009-2RSR
	75	16	21 200	14 400	730	11 200	9 700	15,3	0,253	6009-2Z
	85	19	34 000	20 300	1 370	12 700	9 900	14,3	0,396	6209-C
	85	19	34 000	20 300	1 370	10 800	9 900	14,3	0,414	6209-C-2BRS
	85	19	34 000	20 300	1 370	7 100	–	14,3	0,413	6209-C-2HRS
	85	19	34 000	20 300	1 370	10 800	9 900	14,3	0,411	6209-C-2Z
	85	23	34 500	20 300	1 370	4 650	–	14	0,484	62209-2RSR
	100	36	56 000	31 500	2 180	4 300	–	12,9	1,2	62309-2RSR
	100	25	58 000	31 500	2 140	10 500	9 100	12,9	0,83	6309-C
100	25	58 000	31 500	2 140	8 900	9 100	12,9	0,85	6309-C-2BRS	
100	25	58 000	31 500	2 140	6 400	–	12,9	0,85	6309-C-2HRS	
100	25	58 000	31 500	2 140	8 900	9 100	12,9	0,84	6309-C-2Z	
120	29	83 000	47 500	3 150	8 500	6 800	12,9	1,55	6409	

medias ► <https://www.schaeffler.de/std/1E32>

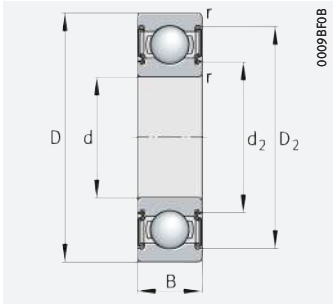

With seal 2BRS, 2HRS, 2RSR, 2Z

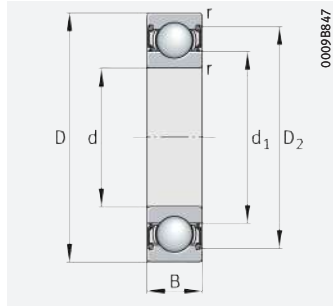

With seal 2RSR, 2RZ, 2Z

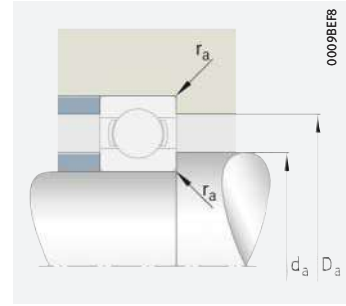

Mounting dimensions



Dimensions						Mounting dimensions		
d	r	D ₁	D ₂	d ₁	d ₂	d _a	D _a	r _a
	min.	≈	≈	≈		min.	max.	max.
45	0,3	–	55,4	49,1	–	47	56	0,3
	0,3	–	55,4	49,1	–	47	56	0,3
	0,3	54,1	–	49,1	–	47	56	0,3
	0,6	60,6	–	52,4	–	48,2	64,8	0,6
	0,6	–	62,1	52,1	–	48,2	64,8	0,6
	0,6	–	62,1	52,1	–	48,2	64,8	0,6
	1	65,5	–	54,2	–	49,6	70,4	1
	0,6	65,7	–	54,2	–	48,2	71,8	0,6
	1	–	68	54,2	–	49,6	70,4	1
	1	–	68	54,2	–	49,6	70,4	1
	1,1	–	75,5	–	53,9	52	78	1
	1,1	–	75,5	–	53,9	52	78	1
	1,1	–	75,5	–	53,9	52	78	1
	1,1	–	75,5	–	53,9	52	78	1
	1,1	–	75,6	–	54,4	52	78	1
	1,5	–	85,6	62	–	54	91	1,5
	1,5	–	86,4	–	60,3	54	91	1,5
	1,5	–	86,4	–	60,3	54	91	1,5
	1,5	–	86,4	–	60,3	54	91	1,5
	1,5	–	86,4	–	60,3	54	91	1,5
2	–	101,1	–	75,2	–	58	107	2



Deep groove ball bearings

Single row

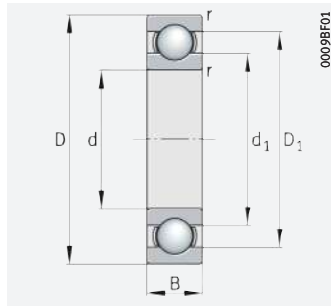

Open

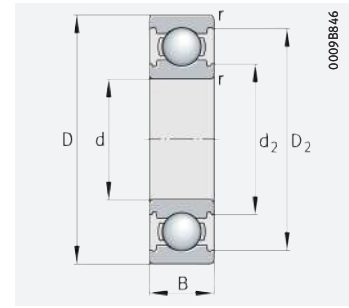

Generation C, open

d = 50 – 50 mm

Main dimensions			Basic load ratings		Fatigue limit load C_{ur} N	Limiting speed n_G min ⁻¹	Speed rating $n_{\partial r}$ min ⁻¹	Factor f_0	Mass m ≈ kg	Designation ► 225 1.12 ► 226 1.13
d	D	B	dyn. C_r N	stat. C_{0r} N						
50	65	7	7 200	6 300	425	4 850	–	16	0,052	61810-2RSR-Y
	65	7	7 200	6 300	425	12 900	6 400	16	0,052	61810-2RZ-Y
	65	7	7 200	6 300	425	19 700	6 400	16	0,052	61810-Y
	72	12	15 400	11 700	680	13 400	8 100	16,1	0,083	61910
	72	12	15 400	11 700	680	4 700	–	16,1	0,13	61910-2RSR
	72	12	15 400	11 700	680	11 400	8 100	16,1	0,13	61910-2RZ
	80	10	17 100	13 200	670	12 500	6 700	16,2	0,175	16010
	80	16	22 000	15 800	770	12 200	8 900	15,6	0,272	6010
	80	16	22 000	15 800	770	10 400	8 900	15,6	0,282	6010-2Z
	80	16	22 000	15 800	770	4 450	–	15,6	0,283	6010-2RSR
	90	20	38 000	23 200	1 540	11 700	9 200	14,4	0,431	6210-C
	90	20	38 000	23 200	1 540	9 900	9 200	14,4	0,48	6210-C-2BRS
	90	20	38 000	23 200	1 540	6 400	–	14,4	0,451	6210-C-2HRS
	90	20	38 000	23 200	1 540	9 900	9 200	14,4	0,448	6210-C-2Z
	90	23	37 500	23 200	1 560	4 250	–	14,4	0,53	62210-2RSR
	110	40	66 000	38 000	2 600	3 950	–	13,1	1,55	62310-2RSR
	110	27	68 000	38 000	2 550	9 500	8 400	13,1	1,1	6310-C
110	27	68 000	38 000	2 550	8 000	8 400	13,1	1,1	6310-C-2BRS	
110	27	68 000	38 000	2 550	5 800	–	13,1	1,12	6310-C-2HRS	
110	27	68 000	38 000	2 550	8 000	8 400	13,1	1,12	6310-C-2Z	
130	31	89 000	52 000	3 500	7 900	6 500	13,2	1,96	6410	

medias ► <https://www.schaeffler.de/std/1E33>

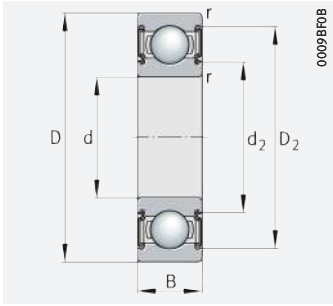

With seal 2BRS, 2HRS, 2RSR, 2Z

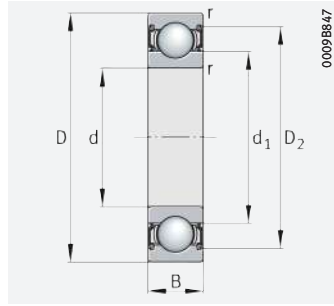

With seal 2RSR, 2RZ, 2Z

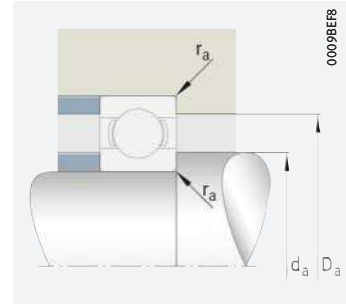

Mounting dimensions



Dimensions						Mounting dimensions		
d	r	D ₁	D ₂	d ₁	d ₂	d _a	D _a	r _a
	min.	≈	≈	≈		min.	max.	max.
50	0,3	–	61,8	55,1	–	52	63	0,3
	0,3	–	61,8	55,1	–	52	63	0,3
	0,3	60,1	–	55,1	–	52	63	0,3
	0,6	65,1	–	56,9	–	53,2	68,8	0,6
	0,6	–	68,6	56,6	–	53,2	68,8	0,6
	0,6	–	67,3	56,9	–	53,2	68,8	0,6
	0,6	71,3	–	59,7	–	53,2	76,8	0,6
	1	70,1	–	59,8	–	54,6	75,4	1
	1	–	72,9	59,8	–	54,6	75,4	1
	1	–	72,9	59,8	–	54,6	75,4	1
	1,1	–	81,8	–	59,1	57	83	1
	1,1	–	81,7	–	59,2	57	83	1
	1,1	–	81,8	–	59,1	57	83	1
	1,1	–	81,8	–	59,1	57	83	1
	1,1	–	82,1	–	58,8	57	83	1
	2	–	95,1	68	–	61	99	2
	2	–	95,2	–	66,7	61	99	2
	2	–	95,2	–	66,7	61	99	2
	2	–	95,2	–	66,7	61	99	2
	2	–	95,2	–	66,7	61	99	2
2,1	108,6	–	81,3	–	64	116	2,1	



Deep groove ball bearings

Single row

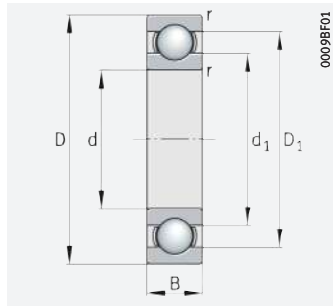

Open

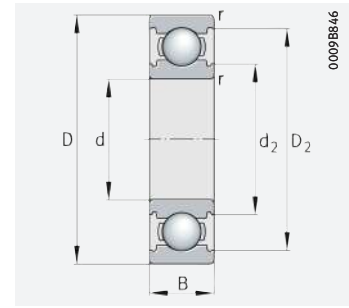

Generation C, open

d = 55 – 55 mm

Main dimensions			Basic load ratings		Fatigue limit load C_{ur} N	Limiting speed n_G min^{-1}	Speed rating $n_{\theta r}$ min^{-1}	Factor f_0	Mass m $\approx \text{kg}$	Designation ► 225 1.12 ► 226 1.13
d	D	B	dyn. C_r N	stat. C_{0r} N						
55	90	18	30 000	21 200	1 120	10 700	8 300	15,3	0,385	6011
	90	18	30 000	21 200	1 120	4 100	–	15,3	0,41	6011-2RSR
	90	18	30 000	21 200	1 120	9 100	8 300	15,3	0,409	6011-2Z
	72	9	9 600	8 500	510	4 400	–	16,3	0,084	61811-2RSR-Y
	72	9	9 600	8 500	510	11 500	6 600	16,3	0,084	61811-2RZ-Y
	72	9	9 600	8 500	510	17 500	6 600	16,3	0,085	61811-Y
	80	13	17 700	14 100	760	12 100	7 500	16,3	0,185	61911
	80	13	17 700	14 100	760	4 250	–	16,3	0,18	61911-2RSR
	80	13	17 700	14 100	760	10 300	7 500	16,3	0,18	61911-2RZ
	90	11	20 600	16 300	910	10 900	6 000	16,2	0,26	16011
	100	21	46 000	29 000	1 720	9 500	7 500	14,2	0,618	6211
	100	21	46 000	29 000	1 720	3 900	–	14,2	0,632	6211-2RSR
	100	21	46 000	29 000	1 720	8 000	7 500	14,2	0,632	6211-2Z
	100	25	44 500	29 000	1 720	3 900	–	14,2	0,737	62211-2RSR
	120	29	83 000	47 500	3 200	8 500	7 800	12,9	1,33	6311-C
	120	29	83 000	47 500	3 200	7 200	7 800	12,9	1,38	6311-C-2BRS
120	29	83 000	47 500	3 200	5 300	–	12,9	1,37	6311-C-2HRS	
120	29	83 000	47 500	3 200	7 200	7 800	12,9	1,37	6311-C-2Z	
140	33	100 000	60 000	3 900	7 300	6 200	13,2	2,29	6411	

medias ► <https://www.schaeffler.de/std/1E34>

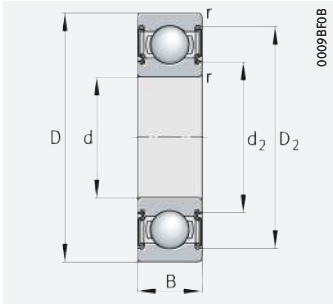

With seal 2BRS, 2HRS, 2RSR, 2Z

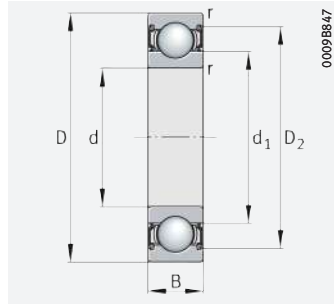

With seal 2RSR, 2RZ, 2Z

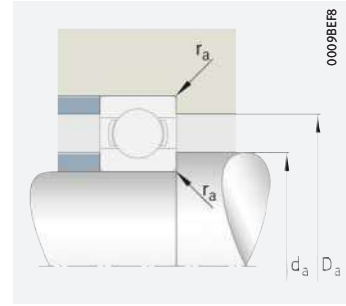

Mounting dimensions



Dimensions						Mounting dimensions			
d	r	D ₁	D ₂	d ₁	d ₂	d _a	D _a	r _a	
	min.	≈	≈	≈		min.	max.	max.	
55	1,1	78,9	–	66,2	–	61	84	1	
	1,1	–	81,5	66,2	–	61	84	1	
	1,1	–	81,5	66,2	–	61	84	1	
	0,3	–	68,6	60,6	–	57	70	0,3	
	0,3	–	68,6	60,6	–	57	70	0,3	
	0,3	66,5	–	60,6	–	57	70	0,3	
	1	71,8	–	63,2	–	59,6	75,4	1	
	1	–	74,2	62,6	–	59,6	75,4	1	
	1	–	74,2	63,2	–	59,6	75,4	1	
	0,6	79	–	65,6	–	58,2	86,8	0,6	
	1,5	86,2	–	68,9	–	64	91	1,5	
	1,5	–	88,2	68,7	–	64	91	1,5	
	1,5	–	88,2	68,7	–	64	91	1,5	
	1,5	–	88,2	68,7	–	64	91	1,5	
	2	–	105,3	–	72,5	72,5	66	109	2
	2	–	105,3	–	72,5	72,5	66	109	2
	2	–	105,3	–	72,5	72,5	66	109	2
	2	–	105,3	–	72,5	72,5	66	109	2
2,1	117,6	–	88,6	–	–	69	126	2,1	



Deep groove ball bearings

Single row

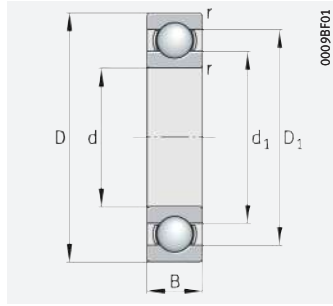

Open

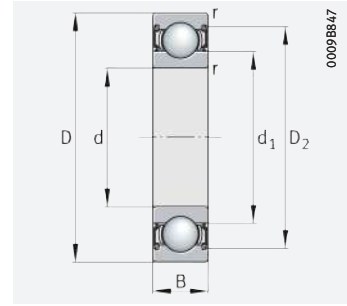

With seal 2RSR, 2RZ, 2Z

d = 60 – 60 mm

Main dimensions			Basic load ratings		Fatigue limit load C_{ur} N	Limiting speed n_G min ⁻¹	Speed rating $n_{\theta r}$ min ⁻¹	Factor f_0	Mass m ≈ kg	Designation ► 225 1.12 ► 226 1.13
d	D	B	dyn. C_r N	stat. C_{0r} N						
60	78	10	12 600	11 100	690	4 100	–	16,3	0,105	61812-2RSR-Y
	78	10	12 600	11 100	690	10 400	6 300	16,3	0,105	61812-2RZ-Y
	78	10	12 600	11 100	690	15 900	6 300	16,3	0,109	61812-Y
	85	13	17 400	14 300	770	11 300	6 900	16,5	0,206	61912
	85	13	17 400	14 300	770	3 950	–	16,5	0,19	61912-2RSR
	95	18	31 500	23 200	1 190	10 100	7 600	15,6	0,419	6012
	95	11	21 200	17 500	820	10 500	5 700	16,3	0,283	16012
	95	18	31 500	23 200	1 190	3 750	–	15,6	0,432	6012-2RSR
	95	18	31 500	23 200	1 190	8 500	7 600	15,6	0,431	6012-2Z
	110	22	57 000	36 500	2 470	9 300	6 800	14,5	0,791	6212
	110	22	57 000	36 500	2 470	3 550	–	14,5	0,809	6212-2RSR
	110	22	57 000	36 500	2 470	7 900	6 800	14,5	0,807	6212-2Z
	110	28	56 000	36 000	2 480	3 550	–	14,3	0,998	62212-2RSR
	130	31	89 000	52 000	3 500	7 900	7 400	13,2	1,71	6312-C
	130	31	89 000	52 000	3 500	6 700	7 400	13,2	1,75	6312-C-2BRS
	130	31	89 000	52 000	3 500	4 800	–	13,2	1,75	6312-C-2HRS
130	31	89 000	52 000	3 500	6 700	7 400	13,2	1,74	6312-C-2Z	
150	35	115 000	69 000	4 450	6 800	5 900	13,4	2,83	6412	

medias ► <https://www.schaeffler.de/std/1E35>

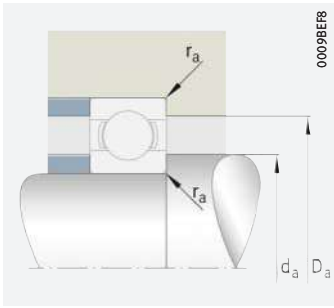

Mounting dimensions

Dimensions						Mounting dimensions			
d	r	D ₁	D ₂	d ₁	d ₂	d _a	D _a	r _a	
	min.	≈	≈	≈		min.	max.	max.	
60	0,3	–	75,3	65,6	–	62	76	0,3	
	0,3	–	74,5	65,6	–	62	76	0,3	
	0,3	72,6	–	65,6	–	62	76	0,3	
	1	76,8	–	68,2	–	64,6	80,4	1	
	1	–	79,2	67,6	–	64,6	80,4	1	
	1,1	83,9	–	71,3	–	66	89	1	
	0,6	83	–	72,1	–	63,2	91,8	0,6	
	1,1	–	86	71,3	–	66	89	1	
	1,1	–	86	71,3	–	66	89	1	
	1,5	95,8	–	75,8	–	69	101	1,5	
	1,5	–	97,7	75,8	–	69	101	1,5	
	1,5	–	97,7	75,8	–	69	101	1,5	
	1,5	–	97,7	75,8	–	69	101	1,5	
	2,1	–	112,1	–	79,6	–	72	118	2,1
	2,1	–	112,1	–	79,6	–	72	118	2,1
	2,1	–	112,1	–	79,6	–	72	118	2,1
	2,1	–	112,1	–	79,6	–	72	118	2,1
2,1	126,3	–	95,1	–	–	74	136	2,1	



Deep groove ball bearings

Single row

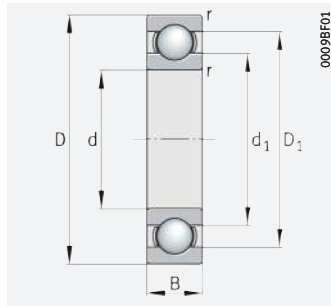

Open

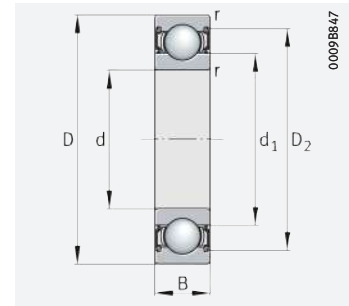

With seal 2RSR, 2RZ, 2Z

d = 65 – 65 mm

Main dimensions			Basic load ratings		Fatigue limit load C_{ur} N	Limiting speed n_G min^{-1}	Speed rating $n_{\theta r}$ min^{-1}	Factor f_0	Mass m \approx kg	Designation ► 225 1.12 ► 226 1.13
d	D	B	dyn. C_r N	stat. C_{0r} N						
65	85	10	13 000	12 000	760	3 750	–	16,2	0,13	61813-2RSR-Y
	85	10	13 000	12 000	760	9 600	5 700	16,2	0,13	61813-2RZ-Y
	85	10	13 000	12 000	760	14 700	5 700	16,2	0,136	61813-Y
	90	13	18 500	16 100	870	10 600	6 400	16,6	0,212	61913
	90	13	18 500	16 100	870	3 650	–	16,6	0,212	61913-2RSR
	90	13	18 500	16 100	810	9 000	6 400	16,6	0,212	61913-2RZ
	100	18	32 500	25 000	1 270	9 500	7 100	15,7	0,448	6013
	100	11	22 500	19 700	910	9 900	5 300	16,5	0,302	16013
	100	18	32 500	25 000	1 270	3 500	–	15,7	0,463	6013-2RSR
	100	18	32 500	25 000	1 270	8 100	7 100	15,7	0,464	6013-2Z
	120	23	63 000	41 500	2 750	8 600	6 300	14,4	1	6213
	120	23	63 000	41 500	2 750	3 250	–	14,4	1,03	6213-2RSR
	120	23	63 000	41 500	2 750	7 300	6 300	14,4	1,03	6213-2Z
	140	33	101 000	60 000	4 000	7 300	7 000	13,2	2,07	6313-C
	140	33	101 000	60 000	4 000	6 200	7 000	13,2	2,13	6313-C-2BRS
	140	33	101 000	60 000	4 000	4 500	–	13,2	2,13	6313-C-2HRS
140	33	101 000	60 000	4 000	6 200	7 000	13,2	2,12	6313-C-2Z	
160	37	123 000	77 000	4 750	6 300	5 600	13,2	3,49	6413	

medias ► <https://www.schaeffler.de/std/1E36>

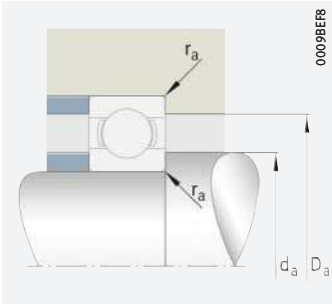

Mounting dimensions

Dimensions						Mounting dimensions		
d	r	D ₁	D ₂	d ₁	d ₂	d _a	D _a	r _a
	min.	≈	≈	≈		min.	max.	max.
65	0,6	–	80,5	71,6	–	68,2	81,8	0,6
	0,6	–	80,5	71,6	–	68,2	81,8	0,6
	0,6	78,6	–	71,6	–	68,2	81,8	0,6
	1	82,3	–	72,6	–	69,6	85,4	1
	1	–	84,2	73,2	–	69,6	85,4	1
	1	–	84,2	72,6	–	69,6	85,4	1
	1,1	88,8	–	76,2	–	71	94	1
	0,6	88	–	77,1	–	68,2	96,8	0,6
	1,1	–	91,5	76,2	–	71	94	1
	1,1	–	91,5	76,2	–	71	94	1
	1,5	103,2	–	82,3	–	74	111	1,5
	1,5	–	106,3	82	–	74	111	1,5
	1,5	–	106,3	82	–	74	111	1,5
	2,1	–	121,4	–	85,6	77	128	2,1
	2,1	–	121,4	–	85,6	77	128	2,1
	2,1	–	121,4	–	85,6	77	128	2,1
	2,1	–	121,4	–	85,6	77	128	2,1
	2,1	133,3	–	101,7	–	79	146	2,1



Deep groove ball bearings

Single row

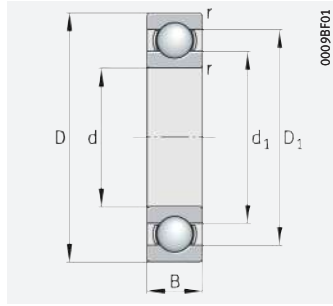

Open

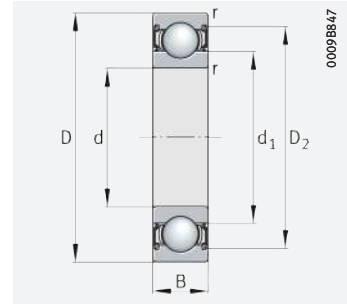

With seal 2RSR, 2RZ, 2Z

d = 70 – 75 mm

Main dimensions			Basic load ratings		Fatigue limit load C_{ur} N	Limiting speed n_G min^{-1}	Speed rating $n_{\theta r}$ min^{-1}	Factor f_0	Mass m $\approx \text{kg}$	Designation ► 225 1.12 ► 226 1.13
d	D	B	dyn. C_r N	stat. C_{0r} N						
70	90	10	13 200	12 400	800	3 500	–	16,1	0,14	61814-2RSR-Y
	90	10	13 200	12 400	800	9 000	5 300	16,1	0,14	61814-2RZ-Y
	90	10	13 200	12 400	800	13 800	5 300	16,1	0,138	61814-Y
	100	16	25 000	21 200	1 160	9 500	6 400	16,4	0,34	61914
	100	16	25 000	21 200	1 160	3 350	–	16,4	0,34	61914-2RSR
	100	16	25 000	21 200	1 160	8 100	6 400	16,4	0,34	61914-2RZ
	110	20	40 500	31 000	1 850	8 600	6 800	15,6	0,622	6014
	110	13	29 500	25 000	1 230	8 900	5 300	16,2	0,438	16014
	110	20	40 500	31 000	1 850	3 250	–	15,6	0,64	6014-2RSR
	110	20	40 500	31 000	1 850	7 300	6 800	15,6	0,642	6014-2Z
	125	24	66 000	44 000	2 950	8 200	6 100	14,4	1,09	6214
	125	24	66 000	44 000	2 950	3 100	–	14,4	1,11	6214-2RSR
	125	24	66 000	44 000	2 950	7 000	6 100	14,4	1,11	6214-2Z
	150	35	115 000	69 000	4 450	6 800	6 100	13,4	2,55	6314
	150	35	115 000	69 000	4 450	2 800	–	13,4	2,6	6314-2RSR
	150	35	115 000	69 000	4 450	5 700	6 100	13,4	2,6	6314-2Z
180	42	141 000	97 000	5 800	5 000	5 200	13,3	5,06	6414	
75	95	10	13 700	13 400	870	3 300	–	16,1	0,15	61815-2RSR-Y
	95	10	13 700	13 400	870	8 500	4 950	16,1	0,15	61815-2RZ-Y
	95	10	13 700	13 400	870	13 000	4 950	16,1	0,15	61815-Y
	105	16	26 000	22 600	1 240	9 000	6 000	16,5	0,36	61915
	115	20	42 000	33 500	1 960	8 100	6 300	15,8	0,654	6015
	115	13	30 500	27 000	1 290	8 400	4 900	16,5	0,463	16015
	115	20	42 000	33 500	1 960	3 050	–	15,8	0,678	6015-2RSR
	115	20	42 000	33 500	1 960	6 900	6 300	15,8	0,676	6015-2Z
	130	25	70 000	49 000	3 250	7 800	5 900	14,6	1,19	6215
	130	25	70 000	49 000	3 250	2 900	–	14,6	1,22	6215-2RSR
	130	25	70 000	49 000	3 250	6 600	5 900	14,6	1,21	6215-2Z
	160	37	123 000	77 000	4 750	6 300	5 800	13,2	3,18	6315
	160	37	123 000	77 000	4 750	2 650	–	13,2	3,18	6315-2RSR
	160	37	123 000	77 000	4 750	5 400	5 800	13,2	3,23	6315-2Z
	190	45	141 000	97 000	5 800	6 600	5 600	13,3	7	6415-M

medias ► <https://www.schaeffler.de/std/1E37>

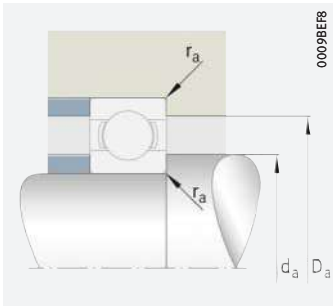

Mounting dimensions



Dimensions					Mounting dimensions		
d	r	D ₁	D ₂	d ₁	d _a	D _a	r _a
	min.	≈	≈	≈	min.	max.	max.
70	0,6	–	85,5	76,6	73,2	86,8	0,6
	0,6	–	85,5	76,6	73,2	86,8	0,6
	0,6	83,6	–	76,6	73,2	86,8	0,6
	1	90,3	–	79,7	74,6	95,4	1
	1	–	92,8	84,1	74,6	95,4	1
	1	–	93,3	79,7	74,6	95,4	1
	1,1	97,3	–	82,8	76	104	1
	0,6	96,2	–	83,7	73,2	106,8	0,6
	1,1	–	100	82,8	76	104	1
	1,1	–	100	82,8	76	104	1
	1,5	108,2	–	86,8	79	116	1,5
	1,5	–	110,7	86,8	79	116	1,5
	1,5	–	110,7	86,8	79	116	1,5
	2,1	126,3	–	95,1	82	138	2,1
	2,1	–	130,2	94,8	82	138	2,1
	2,1	–	130,2	94,8	82	138	2,1
3	151,6	–	114,4	86	164	2,5	
75	0,6	–	90,5	81,6	78,2	91,8	0,6
	0,6	–	90,5	81,6	78,2	91,8	0,6
	0,6	88,6	–	81,6	78,2	91,8	0,6
	1	95,3	–	84,7	79,6	100,4	1
	1,1	102,6	–	88,1	81	109	1
	0,6	101,2	–	88,7	78,2	111,8	0,6
	1,1	–	105,3	88,1	81	109	1
	1,1	–	105,3	88,1	81	109	1
	1,5	113	–	92,1	84	121	1,5
	1,5	–	115,5	92,1	84	121	1,5
	1,5	–	115,5	92,1	84	121	1,5
	2,1	133,3	–	101,8	87	148	2,1
	2,1	–	137,2	101,4	87	148	2,1
	2,1	–	137,2	101,4	87	148	2,1
	3	151,6	–	114,4	91	174	2,5

Deep groove ball bearings

Single row

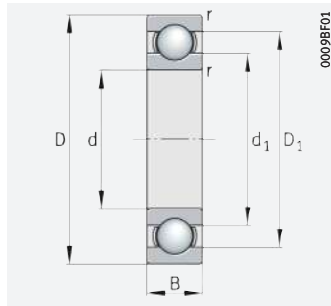

Open

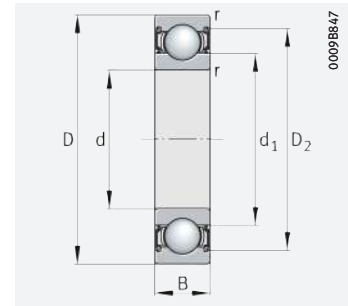

With seal 2RSR, 2RZ, 2Z

d = 80 – 85 mm

Main dimensions			Basic load ratings		Fatigue limit load C_{ur} N	Limiting speed n_G min^{-1}	Speed rating $n_{\theta r}$ min^{-1}	Factor f_0	Mass m $\approx \text{kg}$	Designation ► 225 1.12 ► 226 1.13
d	D	B	dyn. C_r N	stat. C_{0r} N						
80	100	10	13 800	13 800	900	3 100	–	16	0,17	61816-2RSR-Y
	100	10	13 800	13 800	900	8 000	4 600	16	0,155	61816-2RZ-Y
	100	10	13 800	13 800	900	12 300	4 600	16	0,163	61816-Y
	110	16	26 500	24 000	1 320	8 500	5 600	16,6	0,385	61916
	125	22	51 000	40 000	2 340	7 500	6 100	15,7	0,845	6016
	125	14	34 000	31 500	1 510	7 700	4 600	16,6	0,609	16016
	125	22	51 000	40 000	2 340	2 850	–	15,7	0,895	6016-2RSR
	125	22	51 000	40 000	2 340	6 300	6 100	15,7	0,893	6016-2Z
	140	26	77 000	55 000	3 550	7 300	5 500	15	1,46	6216
	140	26	77 000	55 000	3 550	2 700	–	15	1,49	6216-2RSR
	140	26	77 000	55 000	3 550	6 200	5 500	15	1,49	6216-2Z
	170	39	131 000	87 000	5 200	5 400	5 500	13,3	3,75	6316
	170	39	131 000	87 000	5 200	2 470	–	13,3	3,75	6316-2RSR
170	39	131 000	87 000	5 200	4 550	5 500	13,3	3,82	6316-2Z	
200	48	173 000	125 000	6 900	5 900	5 400	12,3	8,29	6416-M	
85	110	13	20 400	19 800	1 130	2 850	–	16,2	0,27	61817-2RSR-Y
	110	13	20 400	19 800	1 130	7 200	4 900	16,2	0,27	61817-2RZ-Y
	110	13	20 400	19 800	1 130	11 100	4 900	16,2	0,27	61817-Y
	120	18	34 000	31 500	1 650	7 700	5 400	16,6	0,557	61917
	130	22	53 000	43 000	2 430	7 100	5 800	15,7	0,917	6017
	130	14	36 000	33 500	1 840	7 400	4 400	16,6	0,666	16017
	130	22	53 000	43 000	2 430	2 700	–	15,7	0,917	6017-2RSR
	130	22	53 000	43 000	2 430	6 100	5 800	15,7	0,94	6017-2Z
	150	28	89 000	64 000	3 950	6 700	5 300	14,8	1,87	6217
	150	28	89 000	64 000	3 950	2 500	–	14,8	1,87	6217-2RSR
	150	28	89 000	64 000	3 950	5 700	5 300	14,8	1,91	6217-2Z
	180	41	141 000	97 000	5 800	5 000	5 300	13,3	4,25	6317
	180	41	141 000	97 000	5 800	2 350	–	13,3	4,25	6317-2RSR
180	41	141 000	97 000	5 800	4 300	5 300	13,3	4,33	6317-2Z	
210	52	184 000	136 000	7 500	5 600	5 300	12,3	9,6	6417-M	

medias ► <https://www.schaeffler.de/std/1E38>

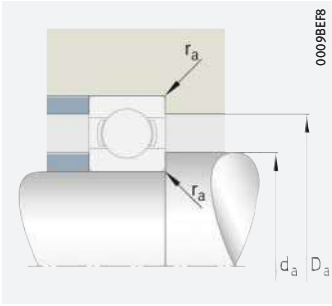

Mounting dimensions



Dimensions					Mounting dimensions		
d	r	D ₁	D ₂	d ₁	d _a	D _a	r _a
	min.	≈	≈	≈	min.	max.	max.
80	0,6	–	95,5	86,6	83,2	96,8	0,6
	0,6	–	95,5	86,6	83,2	96,8	0,6
	0,6	93,6	–	86,6	83,2	96,8	0,6
	1	100,5	–	89,7	84,6	105,4	1
	1,1	111	–	94	86	119	1
	0,6	110,7	–	96,8	83,2	121,8	0,6
	1,1	–	113,7	93,7	86	119	1
	1,1	–	113,7	93,7	86	119	1
	2	121,5	–	98,8	91	129	2
	2	–	124,4	98,5	91	129	2
	2	–	124,4	98,5	91	129	2
	2,1	141,9	–	108,6	92	158	2,1
	2,1	–	145,5	108,2	92	158	2,1
	2,1	–	145,5	108,2	92	158	2,1
85	1	–	104,2	93,2	89,6	105,4	1
	1	–	104,2	93,2	89,6	105,4	1
	1	102	–	93,2	89,6	105,4	1
	1,1	110	–	97,1	89,6	115,4	1
	1,1	116	–	99,6	91	124	1
	0,6	114,7	–	100,9	88,2	126,8	0,6
	1,1	–	119,2	99,2	91	124	1
	1,1	–	119,2	99,2	91	124	1
	2	129,8	–	106,6	96	139	2
	2	–	133,8	106,2	96	139	2
	2	–	133,8	106,2	96	139	2
	3	151,6	–	114,4	99	166	2,5
	3	–	154,9	114	99	166	2,5
	3	–	154,9	114	99	166	2,5
4	173	–	123,4	105	190	3	



Deep groove ball bearings

Single row

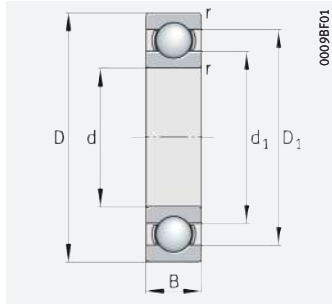

Open

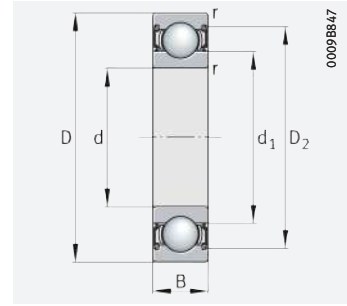

With seal 2RSR, 2RZ, 2Z

d = 90 – 95 mm

Main dimensions			Basic load ratings		Fatigue limit load C_{ur} N	Limiting speed n_G min^{-1}	Speed rating $n_{\theta r}$ min^{-1}	Factor f_0	Mass m $\approx \text{kg}$	Designation ▶ 225 1.12 ▶ 226 1.13
d	D	B	dyn. C_r N	stat. C_{0r} N						
90	115	13	20 700	20 600	1 170	2 700	–	16,1	0,28	61818-2RSR-Y
	115	13	20 700	20 600	1 170	6 900	4 600	16,1	0,28	61818-2RZ-Y
	115	13	20 700	20 600	1 170	10 500	4 600	16,1	0,28	61818-Y
	125	18	33 500	30 500	1 490	7 400	5 200	15,1	0,59	61918
	140	24	62 000	49 500	2 950	6 600	5 600	15,5	1,21	6018
	140	16	44 000	39 500	2 020	6 800	4 400	16,4	0,866	16018
	140	24	62 000	49 500	2 950	2 500	–	15,5	1,21	6018-2RSR
	140	24	62 000	49 500	2 950	5 600	5 600	15,5	1,23	6018-2Z
	160	30	102 000	74 000	4 400	6 300	5 100	14,6	2,21	6218
	160	30	102 000	74 000	4 400	2 380	–	14,6	2,21	6218-2RSR
	160	30	102 000	74 000	4 400	5 400	5 100	14,6	2,26	6218-2Z
	190	43	142 000	102 000	5 800	4 900	5 100	13,9	5,43	6318
	190	43	142 000	102 000	5 800	2 170	–	13,9	5,396	6318-2RSR
190	43	142 000	102 000	5 800	4 150	5 100	13,9	5,53	6318-2Z	
225	54	209 000	162 000	8 900	5 200	4 950	12,1	11,7	6418-M	
95	120	13	21 000	21 300	1 190	2 600	–	16,1	0,295	61819-2RSR-Y
	120	13	21 000	21 300	1 190	6 600	4 350	16,1	0,32	61819-2RZ-Y
	120	13	21 000	21 300	1 190	10 000	4 350	16,1	0,295	61819-Y
	145	24	64 000	54 000	3 050	6 300	5 300	15,8	1,27	6019
	145	16	42 500	41 000	1 990	6 600	4 150	16,6	0,922	16019
	145	24	64 000	54 000	3 050	2 420	–	15,8	1,27	6019-2RSR
	145	24	64 000	54 000	3 050	5 400	5 300	15,8	1,27	6019-2Z
	170	32	116 000	82 000	4 700	5 300	4 950	14,5	2,73	6219
	170	32	116 000	82 000	4 700	2 260	–	14,5	2,73	6219-2RSR
	170	32	116 000	82 000	4 700	4 550	4 950	14,5	2,79	6219-2Z
	200	45	154 000	113 000	6 400	4 600	4 950	13,8	6,23	6319
	200	45	154 000	113 000	6 400	2 080	–	13,8	6,317	6319-2RSR
200	45	154 000	113 000	6 400	3 900	4 950	13,8	6,2	6319-2Z	

medias ▶ <https://www.schaeffler.de/std/1E39>

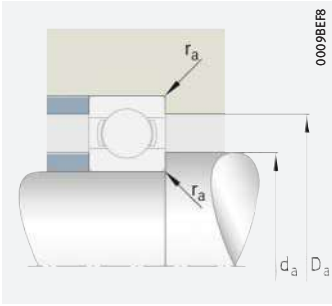

Mounting dimensions



Dimensions					Mounting dimensions		
d	r	D ₁	D ₂	d ₁	d _a	D _a	r _a
	min.	≈	≈	≈	min.	max.	max.
90	1	–	109,2	98,2	94,6	110,4	1
	1	–	109,2	98,2	94,6	110,4	1
	1	107	–	98,2	94,6	110,4	1
	1,1	113,8	–	101,6	96	119	1
	1,5	124,5	–	106,6	97	133	1,5
	1	122,7	–	107,6	94,6	135,4	1
	1,5	–	126,8	106,2	97	133	1,5
	1,5	–	126,8	106,2	97	133	1,5
	2	138,8	–	112,6	101	149	2
	2	–	143,4	112,3	101	149	2
	2	–	143,4	112,3	101	149	2
	3	157,2	–	123,7	104	176	2,5
	3	–	160,7	123,3	104	176	2,5
	3	–	160,7	123,3	104	176	2,5
95	1	–	114,2	103,2	99,6	115,4	1
	1	–	114,2	103,2	99,6	115,4	1
	1	112	–	103,2	99,6	115,4	1
	1,5	129,1	–	111	102	138	1,5
	1	128,4	–	113,8	99,6	140,4	1
	1,5	–	131,8	110,6	102	138	1,5
	1,5	–	131,8	110,6	102	138	1,5
	2,1	146,7	–	118,7	107	158	2,1
	2,1	–	150,9	118,3	107	158	2,1
	2,1	–	150,9	118,3	107	158	2,1
	3	166,9	–	129,1	109	186	2,5
	3	–	170,4	128,7	109	186	2,5
	3	–	170,4	128,7	109	186	2,5



Deep groove ball bearings

Single row

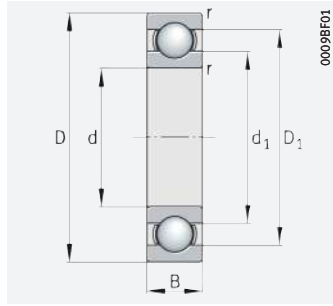

Open

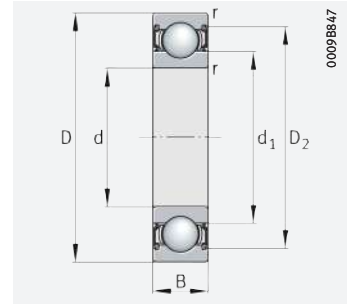

With seal 2RSR, 2RZ, 2Z

d = 100 – 105 mm

Main dimensions			Basic load ratings		Fatigue limit load C_{ur} N	Limiting speed n_G min^{-1}	Speed rating $n_{\partial r}$ min^{-1}	Factor f_0	Mass m $\approx \text{kg}$	Designation ► 225 1.12 ► 226 1.13
d	D	B	dyn. C_r N	stat. C_{0r} N						
100	125	13	21 300	22 100	1 210	2 470	–	16	0,31	61820-2RSR-Y
	125	13	21 300	22 100	1 210	6 300	4 150	16	0,31	61820-2RZ-Y
	125	13	21 300	22 100	1 210	9 600	4 150	16	0,31	61820-Y
	150	24	64 000	54 000	2 950	6 100	5 100	15,8	1,32	6020
	150	16	46 500	44 500	2 140	6 300	4 000	16,5	0,945	16020
	150	24	64 000	54 000	2 950	2 300	–	15,8	1,32	6020-2RSR
	150	24	64 000	54 000	2 950	5 200	5 100	15,8	1,35	6020-2Z
	180	34	130 000	93 000	5 400	5 000	4 800	14,4	3,3	6220
	180	34	130 000	93 000	5 400	2 140	–	14,4	3,3	6220-2RSR
	180	34	130 000	93 000	5 400	4 250	4 800	14,4	3,36	6220-2Z
	215	47	177 000	137 000	7 100	4 250	4 600	13,7	7,67	6320
215	47	177 000	137 000	7 100	1 940	–	13,7	7,78	6320-2RSR	
215	47	177 000	137 000	7 100	3 600	4 600	13,7	7,78	6320-2Z	
105	130	13	22 100	23 600	1 280	2 360	–	15,9	0,33	61821-2RSR-Y
	130	13	22 100	23 600	1 280	6 000	3 900	15,9	0,35	61821-2RZ-Y
	130	13	22 100	23 600	1 280	9 200	3 900	15,9	0,33	61821-Y
	145	20	46 500	44 500	2 140	6 300	4 600	16,5	0,87	61921
	160	26	75 000	64 000	3 450	5 700	4 950	15,7	1,67	6021
	160	18	57 000	54 000	2 390	5 900	3 950	16,5	1,244	16021
	160	26	75 000	64 000	3 450	2 200	–	15,7	1,6	6021-2RSR
	160	26	75 000	64 000	3 450	4 850	4 950	15,7	1,7	6021-2Z
	190	36	141 000	105 000	5 700	4 750	4 650	14,4	3,88	6221
	190	36	141 000	105 000	5 700	2 030	–	14,4	3,73	6221-2RSR
	190	36	141 000	105 000	5 700	4 000	4 650	14,4	3,99	6221-2Z
225	49	188 000	150 000	7 800	4 050	4 450	13,7	8,7	6321	

medias ► <https://www.schaeffler.de/std/1E3A>

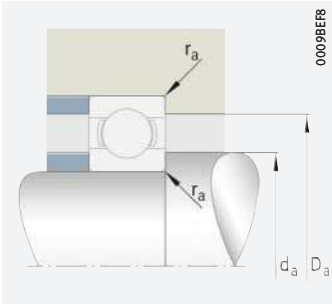

Mounting dimensions



Dimensions					Mounting dimensions		
d	r	D ₁	D ₂	d ₁	d _a	D _a	r _a
	min.	≈	≈	≈	min.	max.	max.
100	1	–	119,2	108,2	104,6	120,4	1
	1	–	119,2	108,2	104,6	120,4	1
	1	117,1	–	108,2	104,6	120,4	1
	1,5	134,1	–	116,6	107	143	1,5
	1	132,7	–	117,6	104,6	145,4	1
	1,5	–	137,3	116,2	107	143	1,5
	1,5	–	137,3	116,2	107	143	1,5
	2,1	155,5	–	125,1	112	168	2,1
	2,1	–	158,9	124,7	112	168	2,1
	2,1	–	158,9	124,7	112	168	2,1
	3	179	–	138,6	114	201	2,5
	3	–	184,6	138,1	114	201	2,5
3	–	184,6	138,1	114	201	2,5	
105	1	–	124,2	113,2	109,6	125,4	1
	1	–	124,2	113,2	109,6	125,4	1
	1	122,1	–	113,2	109,6	125,4	1
	1,1	132,7	–	117,6	111	139	1
	2	142,5	–	122,1	113,8	151,2	2
	1	141,2	–	124,2	109,6	155,4	1
	2	–	145,3	121,7	113,8	151,2	2
	2	–	145,3	121,7	113,8	151,2	2
	2,1	163,2	–	131,9	117	178	2,1
	2,1	–	168,1	131,5	117	178	2,1
	2,1	–	168,1	131,5	117	178	2,1
	3	187,9	–	144,3	119	211	2,5



Deep groove ball bearings

Single row

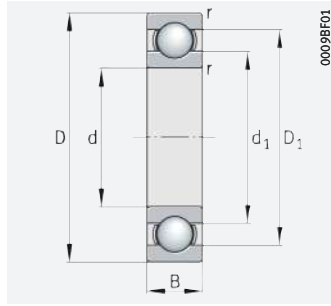

Open

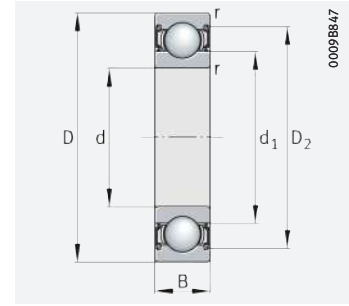

With seal 2RSR, 2RZ, 2Z

d = 110 – 130 mm

Main dimensions			Basic load ratings		Fatigue limit load C_{ur} N	Limiting speed n_G min^{-1}	Speed rating n_{0r} min^{-1}	Factor f_0	Mass m $\approx \text{kg}$	Designation ▶ 225 1.12 ▶ 226 1.13
d	D	B	dyn. C_r N	stat. C_{0r} N						
110	140	16	30 000	30 500	1 610	2 230	–	16	0,5	61822-2RSR-Y
	140	16	30 000	30 500	1 610	5 600	4 100	16	0,5	61822-2RZ-Y
	140	16	30 000	30 500	1 610	8 500	4 100	16	0,5	61822-Y
	170	28	85 000	71 000	3 450	5 300	4 850	15,7	2,06	6022
	170	19	61 000	57 000	2 800	5 500	3 850	16,4	1,52	16022
	170	28	85 000	71 000	3 450	2 080	–	15,7	2,06	6022-2RSR
	170	28	85 000	71 000	3 450	4 550	4 850	15,7	2,11	6022-2Z
	200	38	153 000	117 000	6 300	4 450	4 500	14,3	4,64	6222
	200	38	153 000	117 000	6 300	3 800	4 500	14,3	4,8	6222-2Z
	240	50	201 000	165 000	8 600	3 800	4 150	13,8	10,3	6322
240	50	201 000	165 000	8 600	1 750	–	13,8	10,5	6322-2RSR	
240	50	201 000	165 000	8 600	3 250	4 150	13,8	10,5	6322-2Z	
120	150	16	30 500	33 000	1 680	2 060	–	16	0,55	61824-2RSR-Y
	150	16	30 500	33 000	1 680	5 100	3 750	16	0,55	61824-2RZ-Y
	150	16	30 500	33 000	1 680	7 900	3 750	16	0,56	61824-Y
	180	28	88 000	77 000	3 550	5 000	4 450	15,8	2,18	6024
	180	19	65 000	64 000	3 000	5 200	3 550	16,5	1,62	16024
	180	28	88 000	77 000	3 550	1 920	–	15,8	2,18	6024-2RSR
	180	28	88 000	77 000	3 550	4 250	4 450	15,8	2,23	6024-2Z
	215	40	154 000	123 000	6 200	4 200	4 250	14,8	5,62	6224
	215	40	154 000	123 000	6 200	1 770	–	14,8	5,8	6224-2RSR
	215	40	154 000	123 000	6 200	3 600	4 250	14,8	5,8	6224-2Z
260	55	225 000	195 000	9 500	3 500	3 800	13,8	12,8	6324	
130	165	18	40 500	43 000	1 790	5 500	3 600	16,2	0,801	61826
	180	24	77 000	74 000	3 200	6 400	3 900	16,3	1,7	61926-M
	200	33	113 000	101 000	4 850	4 500	4 350	15,8	3,42	6026
	200	22	84 000	82 000	3 650	4 650	3 450	16,4	2,41	16026
	200	33	113 000	101 000	4 850	1 750	–	15,8	3,16	6026-2RSR
	200	33	113 000	101 000	4 850	3 800	4 350	15,8	3,16	6026-2Z
	230	40	177 000	146 000	7 500	3 850	3 900	14,5	6	6226
	230	40	177 000	146 000	7 500	3 250	3 900	14,5	6,24	6226-2Z
	280	58	244 000	214 000	9 800	3 200	3 500	13,5	15,3	6326

medias ▶ <https://www.schaeffler.de/std/1E3B>

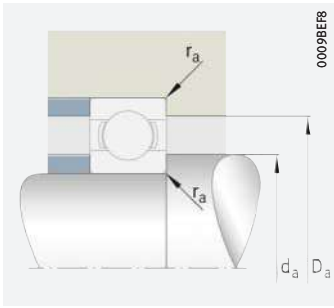

Mounting dimensions



Dimensions					Mounting dimensions		
d	r	D ₁	D ₂	d ₁	d _a	D _a	r _a
	min.	≈	≈	≈	min.	max.	max.
110	1	–	133,3	119,7	114,6	135,4	1
	1	–	133,3	119,7	114,6	135,4	1
	1	130,6	–	119,7	114,6	135,4	1
	2	150,9	–	129,2	118,8	161,2	2
	1	149,5	–	130,7	114,6	165,4	1
	2	–	155	128,7	118,8	161,2	2
	2	–	155	128,7	118,8	161,2	2
	2,1	171,7	–	138,4	122	188	2,1
	2,1	–	177,2	138	122	188	2,1
	3	197,4	–	153,3	124	226	2,5
	3	–	203,1	152,9	124	226	2,5
3	–	203,1	152,9	124	226	2,5	
120	1	–	143,3	129,7	124,6	145,4	1
	1	–	143,3	129,7	124,6	145,4	1
	1	140,6	–	129,7	124,6	145,4	1
	2	161,2	–	139,9	128,8	171,2	2
	1	159,5	–	140,7	124,6	175,4	1
	2	–	165,4	139,4	128,8	171,2	2
	2	–	165,4	139,4	128,8	171,2	2
	2,1	185	–	151,5	132	203	2,1
	2,1	–	190,5	151,1	132	203	2,1
	2,1	–	190,5	151,1	132	203	2,1
3	215	–	165	134	246	2,5	
130	1,1	154,7	–	140	136	159	1
	1,5	164,7	–	145,7	137	173	1,5
	2	177,9	–	153,3	138,8	191,2	2
	1,1	176,7	–	154,7	136	194	1
	2	–	182,1	152,9	138,8	191,2	2
	2	–	182,1	152,9	138,8	191,2	2
	3	198,6	–	161,4	144	216	2,5
	3	–	203,5	161	144	216	2,5
	4	231,3	–	178,9	147	263	3



Deep groove ball bearings

Single row

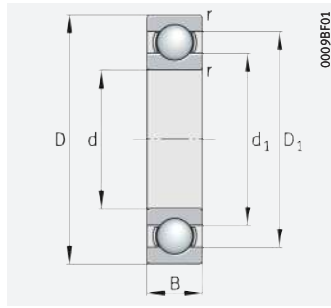

Open

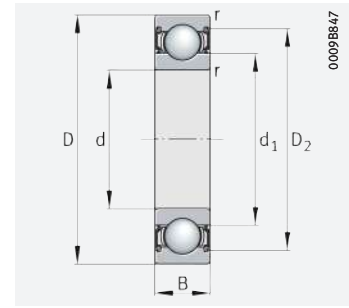

With seal 2RSR, 2RZ, 2Z

d = 140 – 170 mm

Main dimensions			Basic load ratings		Fatigue limit load C_{ur} N	Limiting speed n_G min^{-1}	Speed rating n_{gr} min^{-1}	Factor f_0	Mass m $\approx \text{kg}$	Designation ► 225 1.12 ► 226 1.13
d	D	B	dyn. C_r N	stat. C_{0r} N						
140	175	18	41 500	46 000	1 860	6 700	3 350	16	0,848	61828-Y
	210	33	117 000	109 000	5 000	4 250	4 050	16	3,6	6028
	210	22	86 000	87 000	3 700	4 400	3 200	16,5	2,55	16028
	210	33	117 000	109 000	5 000	1 650	–	16	3,58	6028-2RSR
	210	33	117 000	109 000	5 000	3 600	4 050	16	3,56	6028-2Z
	250	42	188 000	165 000	8 100	3 600	3 600	14,9	8,07	6228
	300	62	270 000	246 000	11 100	3 850	3 250	13,6	21,767	6328-M
150	190	20	54 000	60 000	2 420	4 700	3 200	16,1	1,18	61830
	225	35	131 000	124 000	5 400	3 950	3 850	16	4,32	6030
	225	24	98 000	99 000	4 250	4 050	3 100	16,5	3,17	16030
	225	35	131 000	124 000	5 400	1 540	–	16	4,34	6030-2RSR
	225	35	131 000	124 000	5 400	3 350	3 850	16	4,3	6030-2Z
	270	45	187 000	168 000	7 800	3 350	3 350	15,2	10,3	6230
	320	65	300 000	290 000	13 100	2 800	3 000	13,7	22,4	6330
160	200	20	55 000	62 000	2 430	4 450	3 000	16,1	1,25	61832
	220	28	98 000	99 000	4 250	4 050	3 450	16,5	2,71	61932
	240	38	142 000	136 000	5 800	3 700	3 750	16	5,2	6032
	240	25	109 000	114 000	4 600	3 800	2 950	16,5	3,8	16032
	240	38	142 000	136 000	5 800	1 440	–	16	6,16	6032-2RSR
	240	38	142 000	136 000	5 800	3 150	3 750	16	5	6032-2Z
	290	48	212 000	203 000	8 900	4 050	3 100	15,2	14,7	6232-M
170	215	22	65 000	73 000	2 850	4 100	2 950	16,1	1,63	61834
	230	28	109 000	114 000	4 600	3 800	3 150	16,4	2,83	61934
	260	42	179 000	172 000	7 400	3 400	3 550	15,7	7,13	6034
	260	28	131 000	136 000	5 400	3 500	2 850	16,5	5,15	16034
	260	42	179 000	172 000	7 400	1 340	–	15,7	7,3	6034-2RSR
	310	52	225 000	224 000	9 400	3 800	2 950	15,3	18,3	6234-M

medias ► <https://www.schaeffler.de/std/1E3C>

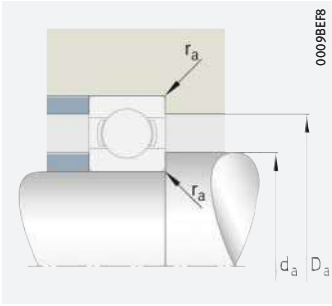

Mounting dimensions



Dimensions					Mounting dimensions		
d	r	D ₁	D ₂	d ₁	d _a	D _a	r _a
	min.	≈	≈	≈	min.	max.	max.
140	1,1	164	–	150,8	146	169	1
	2	187,5	–	162,3	148,8	201,2	2
	1,1	186,7	–	164,3	146	204	1
	2	–	191,3	161,9	148,8	201,2	2
	2	–	191,3	161,9	148,8	201,2	2
	3	213,8	–	175,9	154	236	2,5
	4	248,8	–	191,2	157	283	3
150	1,1	177,9	–	162,7	156	184	1
	2,1	201,4	–	174,4	160,2	214,8	2,1
	1,1	199	–	176	156	219	1
	2,1	–	206	173,9	160,2	214,8	2,1
	2,1	–	206	173,9	160,2	214,8	2,1
	3	229,1	–	191,6	164	256	2,5
	4	266,2	–	205,5	167	303	3
160	1,1	187,3	–	172,7	166	194	1
	2	199	–	176	168,8	211,2	2
	2,1	214,6	–	186,2	170,2	229,8	2,1
	1,5	212,4	–	187,3	167	233	1,5
	2,1	–	219,7	185,8	170,2	229,8	2,1
	2,1	–	219,7	185,8	170,2	229,8	2,1
	3	245	–	204,9	174	276	2,5
170	1,1	200,8	–	184,4	176	209	1
	2	212,6	–	187,2	178,8	221,2	2
	2,1	231,2	–	199,4	180,2	249,8	2,1
	1,5	228,6	–	202,3	177	253	1,5
	2,1	–	236,5	198,9	180,2	249,8	2,1
	4	260,8	–	219	187	293	3



Deep groove ball bearings

Single row

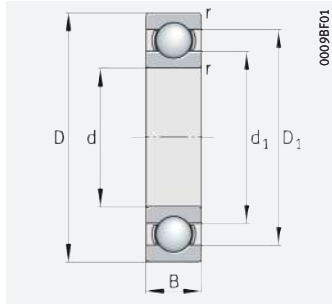

Open

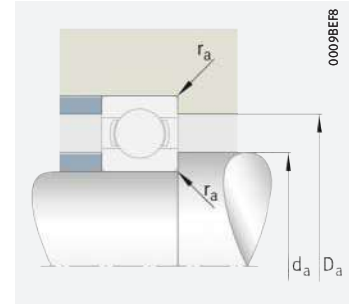

Mounting dimensions

d = 180 – 260 mm

Main dimensions			Basic load ratings		Fatigue limit load C_{ur} N	Limiting speed n_G min^{-1}	Speed rating $n_{\vartheta r}$ min^{-1}	Factor f_0	Mass m $\approx \text{kg}$	Designation ► 225 1.12 ► 226 1.13
d	D	B	dyn. C_r N	stat. C_{0r} N						
180	225	22	66 000	76 000	2 850	3 900	2 750	16,1	1,71	61836
	250	33	131 000	136 000	5 400	3 500	3 200	16,4	4,22	61936
	280	31	140 000	146 000	5 200	3 350	2 950	16,4	6,92	16036
	280	46	201 000	199 000	8 200	4 050	3 300	15,6	10,6	6036-M
	320	52	240 000	244 000	10 300	3 650	2 750	15,3	18,744	6236-M
190	240	24	73 000	85 000	3 300	3 650	2 700	16,1	2,24	61838
	260	33	140 000	146 000	5 200	3 350	3 000	16,4	4,39	61938
	290	31	158 000	168 000	6 300	3 100	2 650	16,5	7,04	16038
	290	46	216 000	220 000	9 100	3 850	3 100	15,6	11,3	6038-M
200	250	24	74 000	88 000	3 350	3 500	2 550	15,9	2,35	61840
	280	38	158 000	168 000	6 300	3 100	2 950	16,4	6,27	61940
	310	34	186 000	202 000	7 300	2 850	2 470	16,4	9	16040
	310	51	231 000	243 000	9 600	3 650	3 000	15,6	14,4	6040-M
220	270	24	78 000	97 000	3 550	3 200	2 320	15,9	2,62	61844
	300	38	186 000	202 000	6 900	2 850	2 600	16,4	6,372	61944
240	300	28	100 000	124 000	4 350	2 900	2 260	15,9	3,769	61848
	320	38	211 000	240 000	8 400	2 600	2 330	16,4	6,88	61948
260	320	28	102 000	132 000	4 550	2 700	2 070	15,9	4,31	61852

medias ► <https://www.schaeffler.de/std/1E3D>



Dimensions				Mounting dimensions		
d	r	D ₁	d ₁	d _a	D _a	r _a
	min.	≈	≈	min.	max.	max.
180	1,1	211,4	194,4	186	219	1
	2	228,9	202,2	188,8	241,2	2
	2	238,8	211,9	188,8	271,2	2
	2,1	249,3	211,8	190,2	269,8	2,1
	4	272,1	228,6	197	303	3
190	1,5	223,8	206,1	197	233	1,5
	2	238,8	211,9	198,8	251,2	2
	2	255,3	225,7	198,8	281,2	2
	2,1	260,3	220,8	200,2	279,8	2,1
200	1,5	233,8	216,7	207	243	1,5
	2,1	255,3	225,7	210,2	269,8	2,1
	2	276,4	244,5	208,8	301,2	2
	2,1	276,3	234,8	210,2	299,8	2,1
220	1,5	255	235,9	227	263	1,5
	2,1	276,4	244,6	230,2	289,8	2,1
240	2	281,6	259,3	248,8	291,2	2
	2,1	298	262,9	250,2	309,8	2,1
260	2	301,7	279,3	268,8	311,2	2



Deep groove ball bearings

Double row

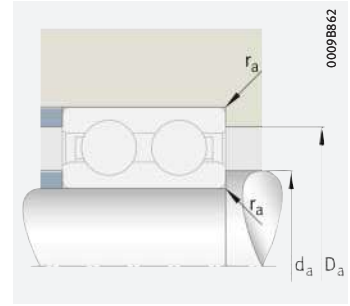
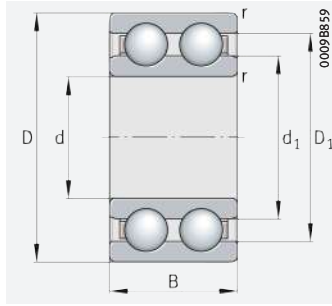

Mounting dimensions

d = 10 – 90 mm

Main dimensions			Basic load ratings		Fatigue limit load C_{Ur} N	Limiting speed n_G min^{-1}	Speed rating $n_{\partial r}$ min^{-1}	Factor f_0	Mass m $\approx \text{kg}$	Designation ▶ 225 1.12 ▶ 226 1.13
d	D	B	dyn. C_r N	stat. C_{Or} N						
10	30	14	8 300	4 750	240	21 800	21 600	13,1	0,051	4200-B-TVH
12	32	14	11 100	6 100	310	19 000	19 100	12,3	0,051	4201-B-TVH
15	35	14	12 400	7 400	375	17 100	16 400	13,1	0,08	4202-B-TVH
	42	17	15 600	9 500	480	14 900	11 600	13	0,125	4302-B-TVH
17	40	16	15 600	9 500	480	14 900	15 100	13	0,1	4203-B-TVH
	47	19	20 900	13 200	670	12 500	9 800	13,1	0,178	4303-B-TVH
20	47	18	20 900	13 200	670	12 500	13 300	13,1	0,14	4204-B-TVH
	52	21	26 000	16 800	850	11 100	9 300	13	0,19	4304-B-TVH
25	52	18	22 900	15 700	790	11 100	11 200	13,8	0,19	4205-B-TVH
	62	24	34 500	22 900	1 160	9 400	8 500	13	0,28	4305-B-TVH
30	62	20	29 000	21 600	1 100	9 400	9 600	14,2	0,28	4206-B-TVH
	72	27	44 000	30 000	1 530	8 000	7 500	13	0,5	4306-B-TVH
35	72	23	39 500	30 000	1 520	7 900	8 700	14,1	0,45	4207-B-TVH
	80	31	58 000	40 500	2 060	6 900	6 900	12,9	0,59	4307-B-TVH
40	80	23	42 000	34 500	1 740	7 200	7 500	14,7	0,45	4208-B-TVH
	90	33	67 000	48 000	2 430	6 100	6 300	13,2	0,83	4308-B-TVH
45	85	23	44 500	38 000	1 930	6 700	6 900	14,9	0,54	4209-B-TVH
	100	36	75 000	60 000	3 600	5 400	5 300	13,9	1,23	4309-B-TVH
50	90	23	46 500	42 000	2 130	6 300	6 300	15,2	0,68	4210-B-TVH
	110	40	92 000	76 000	4 450	4 800	5 000	13,8	1,62	4310-B-TVH
55	100	25	43 000	42 500	2 140	5 700	5 900	15,4	0,808	4211-B-TVH
	120	43	111 000	90 000	5 400	4 350	4 650	13,8	2,06	4311-B-TVH
60	110	28	56 000	56 000	2 850	5 000	5 400	15	1,09	4212-B-TVH
	130	46	128 000	106 000	6 200	3 950	4 350	13,8	2,58	4312-B-TVH
65	120	31	67 000	67 000	3 350	4 650	5 400	15,3	1,44	4213-B-TVH
	140	48	137 000	114 000	6 800	3 850	4 500	13,8	3,49	4313-B-TVH
70	125	31	70 000	71 000	3 600	4 300	4 800	15	1,5	4214-B-TVH
	150	51	156 000	131 000	7 700	3 550	4 200	13,7	3,99	4314-B-TVH
75	130	31	72 000	76 000	3 750	4 100	4 450	14,9	1,58	4215-B-TVH
80	140	33	81 000	90 000	4 350	3 800	4 200	15,7	1,98	4216-B-TVH
85	150	36	94 000	106 000	4 950	3 500	4 100	15,8	2,5	4217-B-TVH
90	160	40	113 000	123 000	5 900	3 300	4 100	15,5	3,15	4218-B-TVH

medias ▶ <https://www.schaeffler.de/std/1E3E>



Dimensions				Mounting dimensions		
d	r	D ₁	d ₁	d _a	D _a	r _a
	min.	≈	≈	min.	max.	max.
10	0,6	23	16,6	14,2	25,8	0,6
12	0,6	25,8	17,8	16,2	27,8	0,6
15	0,6	28,8	21,4	19,2	30,8	0,6
	0,6	32,9	23,8	20,6	36,4	0,6
17	0,6	32,9	23,8	21,2	35,8	0,6
	1	38,5	28,4	22,6	41,4	1
20	1	38,5	28,4	25,6	41,4	1
	1,1	42,3	31,5	27	45	1
25	1	43,6	33,6	30,6	46,4	1
	1,1	49,9	37	32	55	1
30	1	51,8	39,9	35,6	56,4	1
	1,1	59,4	42,6	37	65	1
35	1,1	60,4	46,3	42	65	1
	1,5	68	48,2	44	71	1,5
40	1,1	67,2	53	47	73	1
	1,5	75,6	54,5	49	81	1,5
45	1,1	72,2	58,1	52	78	1
	1,5	86,8	66,7	54	91	1,5
50	1,1	76,9	62,8	57	83	1
	2	96,2	73,6	61	99	2
55	1,5	84,7	71,4	64	91	1,5
	2	105,3	80,4	66	109	2
60	1,5	95,3	79,8	69	101	1,5
	2,1	113,8	87,7	72	118	2,1
65	1,5	101,9	84,2	74	111	1,5
	2,1	116,2	89,2	77	128	2,1
70	1,5	109,4	91,7	79	116	1,5
	2,1	127,1	97,3	82	138	2,1
75	1,5	115	97,6	84	121	1,5
80	2	124	105,2	91	129	2
85	2	132,8	112,7	96	139	2
90	2	140,2	117,6	101	149	2

Angular contact ball bearings



Matrix for bearing preselection280

1 Single row angular contact ball bearings **282**

- 1.1 Bearing design 282
- 1.2 Load carrying capacity 286
- 1.3 Compensation of angular misalignments 287
- 1.4 Lubrication 287
- 1.5 Sealing 288
- 1.6 Speeds 288
- 1.7 Noise 289
- 1.8 Temperature range 290
- 1.9 Cages 290
- 1.10 Internal clearance 291
- 1.11 Dimensions, tolerances 292



1.12	Suffixes	293
1.13	Structure of bearing designation	293
1.14	Dimensioning	294
1.15	Minimum load	298
1.16	Design of bearing arrangements	298
1.17	Mounting and dismounting	301
1.18	Legal notice regarding data freshness	301
1.19	Further information	302

Product table	304
---------------	-----

 Angular contact ball bearings, single row	304
---	-----

2 Double row angular contact ball bearings **314**

2.1	Bearing design	314
2.2	Load carrying capacity	317
2.3	Compensation of angular misalignments	317
2.4	Lubrication	317
2.5	Sealing	318
2.6	Speeds	318

2.7	Noise	318
2.8	Temperature range	319
2.9	Cages	320
2.10	Internal clearance	320
2.11	Dimensions, tolerances	321
2.12	Suffixes	322
2.13	Structure of bearing designation	322
2.14	Dimensioning	323
2.15	Minimum load	324
2.16	Design of bearing arrangements	325
2.17	Mounting and dismounting	327
2.18	Legal notice regarding data freshness	327
2.19	Further information	328

Product table	330
---------------	-----

 Angular contact ball bearings, double row	330
---	-----



Matrix for bearing preselection

The matrix gives an overview of the types and design features of angular contact ball bearings.

It can be used to make a preliminary assessment of whether a bearing is fundamentally suitable for the envisaged application.

The additional information provided in the product chapter (see column "detailed information") and in the Technical principles must, however, be observed in addition to this overview in selection of the bearing.

Design features and suitability			Single row angular contact ball bearings	
			single row	detailed information
+++ extremely suitable ++ highly suitable + suitable (+) suitable with restrictions - not suitable ✓ available				282
Load carrying capacity	radial		++	▶ 286 1.2
	axial, one direction		++	▶ 286 1.2
	axial, both directions		++ ¹⁾	▶ 286 1.2
	moments		++ ¹⁾	▶ 286 1.2
Compensation of angular misalignments	static		-	▶ 287 1.3
	dynamic		-	▶ 287 1.3
Bearing design	cylindrical bore		✓	▶ 282 1.1
	tapered bore		-	
	separable		-	▶ 301 1.17
Lubrication	greased		✓ ³⁾	▶ 287 1.4 ▶ 70
Sealing	open		✓	▶ 288 1.5 ▶ 182
	non-contact		✓	▶ 288 1.5
	contact		✓	▶ 288 1.5
Operating temperature in °C		from to	-30 +150 ⁴⁾	▶ 290 1.8
Suitability for	high speeds		+++	▶ 288 1.6
	high running accuracy		+	▶ 114
	low-noise running		++	▶ 289 1.7 ▶ 282
	high rigidity		++	▶ 54
	reduced friction		++	▶ 56
	length compensation within bearing		-	
	non-locating bearing arrangement		+ ¹⁾	▶ 139
locating bearing arrangement		+++ ¹⁾	▶ 139	
X-life design			✓	▶ 285
Bearing bore d in mm		from to	10 180 ⁵⁾	▶ 304
Product tables		from page	304	

1) For mounting in pairs only, O or X arrangement
 2) Valid for bearings with split inner ring
 3) Valid for bearings sealed on both sides
 4) Valid for open, ungreased bearings with sheet steel or brass cage
 5) Larger catalogue bearings
 ▶ GL 1



Double row angular contact ball bearings		
double row	detailed information	
	314	
++	317 2.2	
++	317 2.2	
++	317 2.2	
+	317 2.2	
-	317 2.3	
-	317 2.3	
✓	314 2.1	
-		
✓ ²⁾	327 2.17	
✓ ³⁾	317 2.4 70	
✓	318 2.5 182	
✓	318 2.5	
✓	318 2.5	
-30 +150 ⁴⁾	319 2.8	
+	318 2.6	
++	114	
++	318 2.7 315	
++	54	
++	56	
-		
+	139	
++	139	
✓	316	X-life
5 110 ⁵⁾	330	
330		



1 Single row angular contact ball bearings



Single row angular contact ball bearings are particularly suitable where:

- bearing arrangements must support combined loads, i. e. radial and axial loads acting simultaneously ▶ 283 | 2
- moderate to high axial loads are present on one side
- rigid axial guidance is required
- the bearing arrangement must be axially clearance-free or preloaded
- high speeds are required under higher radial and axial loads
- the bearing arrangement is to run quietly in addition to meeting the requirements stated above.

For an overview of other product-specific features, see the Matrix for bearing preselection ▶ 280.

 **1**
Angular contact ball bearings:
speed comparison
with tapered roller bearings
 $n_G = \text{limiting speed}$

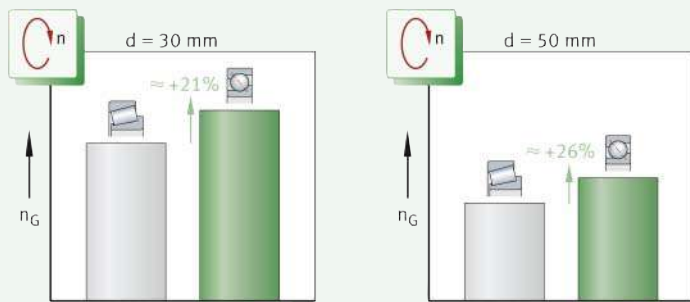

1.1 Bearing design

Design variants

The standard product range comprises bearings of series 718...-B, 70...-B(-2RS), 72...-B(-2RS), 73...-B(-2RS) and 74...-B.

These bearings are also available for various applications as:

- bearings of basic design for bearing arrangements with single bearings ▶ 283 | 2
- universal bearings for installation in sets in a tandem, O or X arrangement ▶ 284 | 3, ▶ 284 | 4, ▶ 285 | 5
- X-life bearings ▶ 285.



Single row angular contact ball bearings are also available in other dimension series, designs and sizes. Information on these bearings is available from Schaeffler on request. Larger catalogue bearings ▶ GL 1.

Bearings of basic design for bearing arrangements with single bearings

☞ *The forces are transmitted oblique to the radial plane*

Single row angular contact ball bearings are part of the group of radial ball bearings. These self-retaining units have solid outer and inner rings. The rolling elements are guided by cages made from polyamide, sheet steel, or brass. The bearing rings are designed with one high shoulder and one low shoulder ▶283|☐2. As a result of the different shoulder heights, the mounting method differs from that of deep groove ball bearings. The possible number of balls for angular contact ball bearings with identical dimensions is higher than for deep groove ball bearings. In contrast to deep groove ball bearings, the raceways on the inner and outer rings are arranged obliquely to each other in the direction of the bearing axis. As a result, the forces are transmitted from one raceway to the other at a defined contact angle (oblique to the radial plane) ▶287|☐7.



☞ *For bearing positions with only one bearing each*

These angular contact ball bearings can be considered when only one bearing is used per bearing position. As the bearings have standard bearing ring tolerances (they are manufactured to tolerance class Normal), they are not suitable for mounting directly adjacent to each other. In such cases, universal bearings should be used.

☐2
Single row angular contact ball bearing of basic design

F_r = radial load

F_a = axial load

α = nominal contact angle

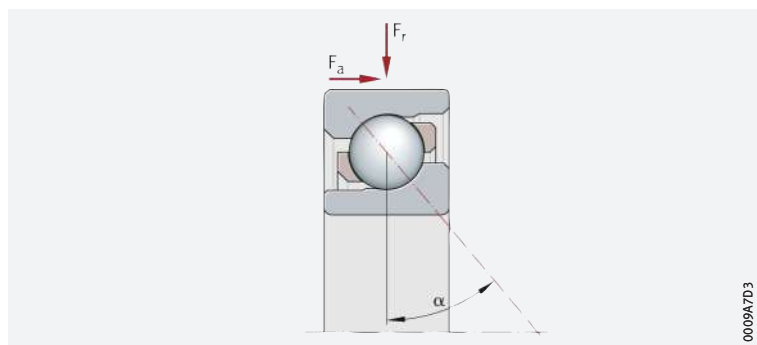

0009A7D3

☞ *Bearings can be mounted in pairs in any arrangement required*

Universal bearings for mounting in sets

Single row angular contact ball bearings, which are intended for mounting in pairs (in sets) directly adjacent to each other, are manufactured in the so-called universal design ▶284|☐3, ▶284|☐4, ▶285|☐5. These bearings can be used in pairs in any arrangement without shims. Depending on the design selected, the mounted bearing pair has the required axial clearance, freedom from clearance or preload. This gives easier design of the bearing arrangement and mounting of the bearings.



When ordering, please state the number of bearings, not the number of bearing pairs.

☞ *Suffixes: UA, UB, UO, UL, UM, UH*

Bearings of a universal design are indicated by the suffix UA, UB, UO, UL, UM or UH ▶293|☐6. If bearings of the universal design are arranged in sets, this gives a defined axial clearance or an axial preload:

- UA = bearing set with small axial internal clearance
- UB = bearing set with smaller axial internal clearance than UA
- UO = bearing set clearance-free in O or X arrangement
- UL = bearing set with light preload
- UM = bearing set with moderate preload
- UH = bearing set with high preload.

Reasons for mounting in sets

- Single row angular contact ball bearings are mounted in sets if:
- the load carrying capacity of one bearing is not sufficient (bearing set in a tandem arrangement)
 - combined or axial loads occur in both directions and the bearing arrangement must have a defined axial clearance (bearing set in O or X arrangement).

The following arrangements are possible for mounting in sets:

- tandem arrangement ▶ 284 | 3
- O arrangement ▶ 284 | 4
- X arrangement ▶ 285 | 5.

Bearing sets in tandem arrangement

Tandem arrangement

In a tandem arrangement, the contact lines run parallel to each other ▶ 284 | 3. Axial forces are distributed equally over both bearings, but can only be supported by the bearing set from one direction. In order to support axial forces from the opposing direction, as well as combined loads, the bearing set is always adjusted against a further bearing.



Universal bearings, mounted in set in a tandem arrangement

Bearing set in tandem arrangement

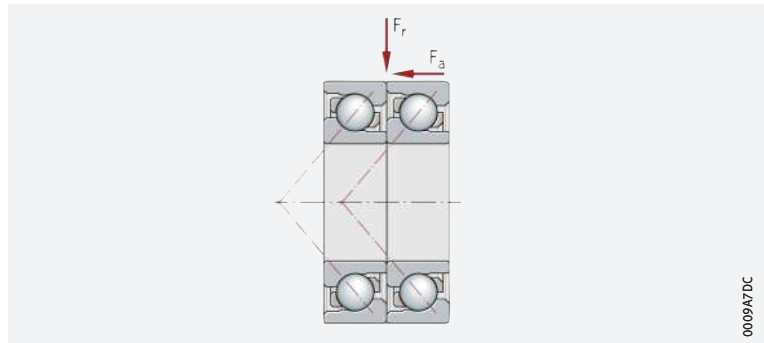

Bearing sets in O arrangement

O arrangement

In an O arrangement, the apexes of the cones formed by the contact lines point outwards, i.e. they diverge relative to the bearing axis ▶ 284 | 4. Bearing sets in an O arrangement support axial forces from both directions, but only ever with one bearing. Due to the large support spacing (i.e. the spacing between the contact cone apexes), these give relatively rigid bearing arrangements (small tilting clearance) and are also suitable for supporting tilting moments.



Universal bearings, mounted in set in an O arrangement

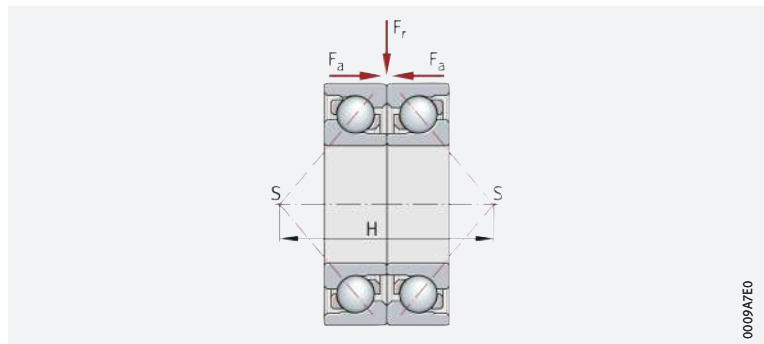

Bearing set in O arrangement

- S = contact cone apex
- H = support spacing



X arrangement

Bearing sets in X arrangement

In an X arrangement, the apexes of the cones formed by the contact lines point inwards, i. e. they converge relative to the bearing axis  285  5. Once again, bearing sets of this type support axial forces from both directions, but also only ever with one bearing. The support base is, however, smaller than in an O arrangement. As a result, the sets are not as rigid as in an O arrangement. Furthermore, they are less suitable for supporting tilting moments.

 5
Universal bearings,
mounted in set
in an X arrangement



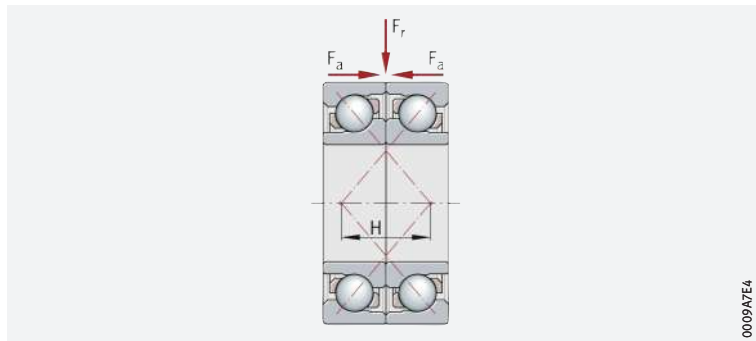

Bearing set in X arrangement

H = support spacing



X-life



X-life premium quality

Many sizes in series 70...-B, 72...-B, 73...-B and 74...-B are available as X-life bearings  304 . These bearings exhibit considerably higher performance than standard single row angular contact ball bearings  286  6. This is achieved, for example, through the modified internal construction, higher surface quality of the contact surfaces and optimised cage design, as well as through the improved quality of the steel and rolling elements.

Advantages

 Increased customer benefits due to X-life

The technical enhancements offer a range of advantages, such as:

- a more favourable load distribution in the bearing and thus a higher dynamic load carrying capacity of the bearings  286  6
- quieter running
- running with reduced friction and greater energy efficiency
- lower heat generation in the bearing
- higher possible speeds
- lower lubricant consumption and, consequently, longer maintenance intervals
- a measurably longer operating life of the bearings
- high operational security
- compact, environmentally-friendly bearing arrangements.

 Lower operating costs, higher machine availability

In conclusion, these advantages improve the overall cost-efficiency of the bearing position significantly and thus bring about a sustainable increase in the efficiency of the machine and equipment.

Suffix XL Single row X-life angular contact ball bearings include the suffix XL in the designation ➤ 293|⊕ 9, ➤ 294|⊕ 10 and ➤ 304|⊕ 11.

6
Comparison of basic dynamic load rating C_r – bearing series 73..-B-XL, bore code 05 to 26, with a bearing which is not of X-life quality (73..-B)

C_r = basic dynamic load rating

① Bore code

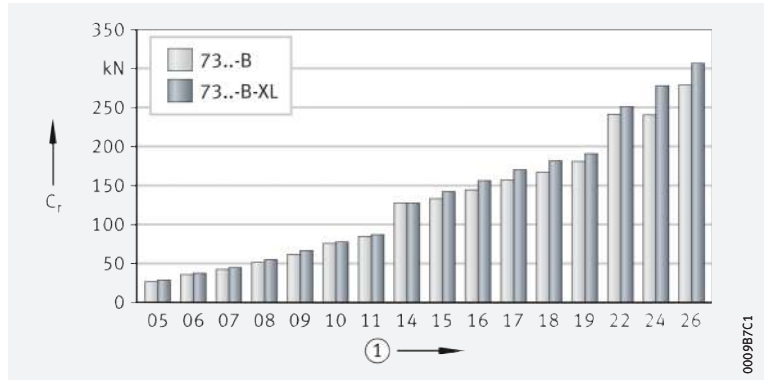

Areas of application

Wide application range

Due to their special technical features, single row X-life angular contact ball bearings are highly suitable for bearing arrangements in:

- compressors
- fluid and hydraulic pumps
- automotive chassis and gearboxes
- industrial gearboxes
- electric motors
- industrial ventilators
- machine tools
- textile machinery.



X-life indicates a high product performance density and thus a particularly significant benefit to the customer. Further information on X-life ➤ 10.

1.2 Load carrying capacity

Radial load

Single row angular contact ball bearings can support high radial forces. Pure radial loads are also possible, if the bearings are adjusted.

Axial loading is only possible on one side

Due to the geometry and position of the raceway shoulders, axial loads are only transmitted from one direction ➤ 283|⊕ 2. If these angular contact ball bearings are required to support axial forces from both directions, they are adjusted against a second bearing in a mirror image arrangement ➤ 295|⊕ 11 and ➤ 295|⊕ 12.

The axial load carrying capacity of the bearings increases with the size of the contact angle

The contact angle α is the angle encompassed by the contact line and the radial plane, under which the load is transmitted from one raceway to the other ➤ 287|⊕ 7. The axial load carrying capacity of the bearing increases with the value of α , i.e. the greater the angle, the higher the axial load to which the bearing can be subjected. As a result, angular contact ball bearings are more suitable than deep groove ball bearings for supporting higher axial forces. Due to the nominal contact angle of $\alpha = 40^\circ$, single row angular contact ball bearings can support high axial loads on one side.



For information on angular contact ball bearings available with contact angles other than $\alpha = 40^\circ$, please consult Schaeffler.

7 Contact angle and force flow

α = contact angle

- ① Contact line
- ② Force flow

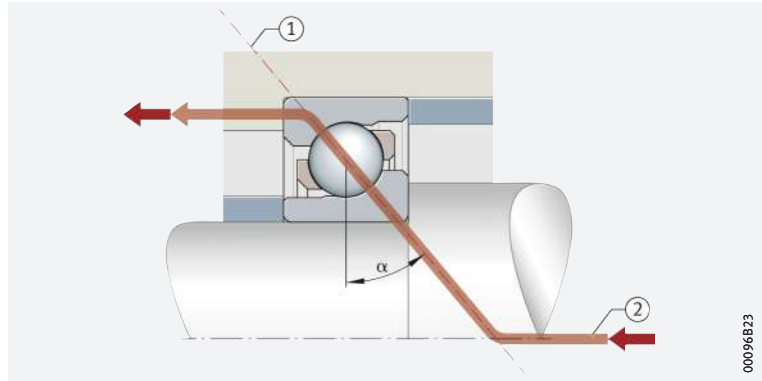

Load carrying capacity of bearing sets



The basic dynamic and static load ratings C_r and C_{0r} in the product tables always refer to the single bearing. If two bearings of the same size and design are arranged immediately adjacent to each other in an O or X arrangement, the following will apply to the bearing pairs:

- $C_r = 1,625 \cdot C_{r \text{ single bearing}}$
- $C_{0r} = 2 \cdot C_{0r \text{ single bearing}}$

1.3

Compensation of angular misalignments

The angular adjustment facility of the bearings is very limited

Single row angular contact ball bearings are not suitable for the compensation of angular misalignments. In addition, misalignments induce internal forces in the bearing, which not only lead to higher temperatures, but also to a reduction in the bearing rating life.

Angular contact ball bearings arranged in sets



Misalignments in angular contact ball bearings mounted in sets lead – particularly with a small internal clearance and an O arrangement – to increased loads on the balls and cage, as the angular misalignments are supported under constraint between the balls and raceways. This can, in turn, have a negative effect on the operating life of the bearings. In addition, it should be noted that running noise is increased by a misalignment of the bearing rings.

1.4

Lubrication

Greased bearings are maintenance-free

Angular contact ball bearings sealed on both sides are greased with a high quality grease and do not require relubrication.

Ungreased bearings must be lubricated

Open bearings and bearings with seals on one side are not greased. These bearings must be lubricated with oil or grease.

Compatibility with plastic cages

When using bearings with plastic cages, compatibility between the lubricant and the cage material must be ensured if synthetic oils, lubricating greases with a synthetic oil base or lubricants containing a high proportion of EP additives are used.

Observe oil change intervals

Aged oil and additives in the oil can impair the operating life of plastics at high temperatures. As a result, stipulated oil change intervals must be strictly observed.

1.5 Sealing

☞ *Sealing with contact seals 2RS*

Bearings with the suffix 2RS have lip seals on both sides ▶ 293 | 6. Due to their good sealing action, they are suitable for use in dusty, contaminated or damp environments.

☞ *Open bearings*

In the case of unsealed bearings, sealing of the bearing position must be carried out by the adjacent construction. The sealing system should reliably prevent:

- moisture and contaminants from entering the bearing
- the egress of lubricant from the bearing.

1.6 Speeds

☞ *Limiting speeds and reference speeds in the product tables*

Two speeds are generally indicated in the product tables ▶ 304 | 6:

- the kinematic limiting speed n_G
- the thermal speed rating n_{Dr} .

Limiting speeds



The limiting speed n_G is the kinematically permissible speed of the bearing. Even under favourable mounting and operating conditions, this value should not be exceeded without prior consultation with Schaeffler ▶ 64.

The values given in the product tables are valid for oil lubrication in the case of bearings without seals or shields and for grease lubrication where bearings are supplied greased and with seals or shields.

☞ *Values for grease lubrication*

For grease lubrication, 75% of the value stated in the product tables is permissible in each case.

Reference speeds

☞ *n_{Dr} is used to calculate n_D*

The thermal speed rating n_{Dr} is not an application-oriented speed limit, but is a calculated ancillary value for determining the thermally safe operating speed n_D ▶ 64.

☞ *Bearings with contact seals*

For bearings with contact seals, no reference speeds are defined in accordance with DIN ISO 15312:2004. As a result, only the limiting speed n_G is given in the product tables for these bearings.

Bearing sets of universal design

☞ *Bearing pairs usually operate at lower speeds than single bearings*

Angular contact ball bearings of universal design can be used in an X, O or tandem arrangement ▶ 284 | 3 to ▶ 285 | 5. The thermally safe operating speed of the bearing pair is then approximately 20% below the calculated permissible operating speed of the single bearing.

1.7 Noise

The Schaeffler Noise Index (SGI) has been developed as a new feature for comparing the noise level of different bearing types and series. As a result, a noise evaluation of rolling bearings can now be carried out for the first time.

Schaeffler Noise Index

The SGI value is based on the maximum permissible noise level of a bearing in accordance with internal standards, which is calculated on the basis of ISO 15242. In order that different bearing types and series can be compared, the SGI value is plotted against the basic static load rating C_0 .

This permits direct comparisons between bearings with the same load carrying capacity. The upper limit value is given in each of the diagrams. This means that the average noise level of the bearings is lower than illustrated in the diagram.

 The Schaeffler Noise Index is an additional performance characteristic in the selection of bearings for noise-sensitive applications. The specific suitability of a bearing for an application in terms of installation space, load carrying capacity or speed limit for example, must be checked independently of this.

 The Noise Index is currently available for the main series. Additional series will be updated and introduced in subsequent publications.

Further information:

■ **medias** ► <https://medias.schaeffler.com>.

 **Schaeffler Noise Index**
for single row angular contact
ball bearings

SGI = Schaeffler Noise Index
 C_0 = basic static load rating

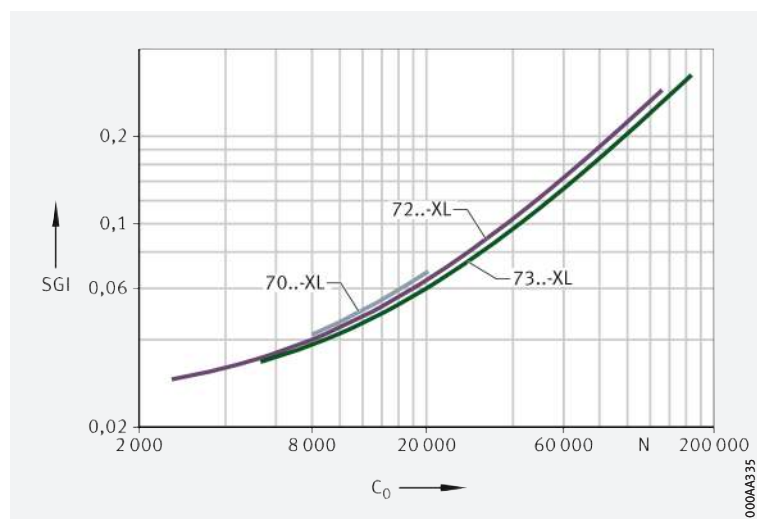

1.8 Temperature range

 **Limiting values**

- The operating temperature of the bearings is limited by:
- the dimensional stability of the bearing rings and rolling elements
 - the cage
 - the lubricant
 - the seals.

Possible operating temperatures of single row angular contact ball bearings **> 290** |  1.

 **1**
Permissible temperature ranges

Operating temperature	Single row angular contact ball bearings, open		Single row angular contact ball bearings, sealed
	with sheet steel or brass cage	with polyamide cage PA66	
	-30 °C to +150 °C, for D > 240 mm up to +200 °C	-30 °C to +120 °C	-30 °C to +110 °C, limited by the lubricant and seal material



In the event of anticipated temperatures which lie outside the stated values, please contact Schaeffler.

1.9 Cages

Solid cages made from brass and PA66, as well as sheet steel cages, are used as standard

Standard cages and additional cage designs for single row angular contact ball bearings are made from brass, polyamide or steel **> 290** |  2. Other cages are available by agreement. With such cages, however, suitability for high speeds and temperatures as well as the basic load ratings may differ from the values for the bearings with standard cages.



For high continuous temperatures and applications with difficult operating conditions, bearings with brass or sheet steel cages should be used. If there is any uncertainty regarding cage suitability, please consult Schaeffler.

 **2**
Cage, cage suffix, bore code

Bearing series	Solid cage made from polyamide PA66		Solid brass cage		Sheet steel cage
	TVH, TVP	MP	JP	also available for	
	standard	also available for	standard	also available for	also available for
Bore code					
718	06 to 16	-	-	-	-
70	04 to 08	-	-	-	-
72	up to 20, 22 to 26	-	21, from 28	00, 03, from 05	up to 20, 22
73	up to 20, 22 to 26	-	21, from 28	from 04	up to 20, 22
74	-	07 to 15	05 to 16	-	07 to 15

1.10 Internal clearance

Valid for bearing sets in O or X arrangement

Axial internal clearance, preload and preload force of bearing sets with universal bearings in O or X arrangement

Values for axial internal clearance, preload and preload force of bearings of universal design ▶ 291 | 3. The values for axial internal clearance are valid for unmounted bearing sets in an O or X arrangement, which are free from load and measurement forces (without elastic deformation).



The angular contact ball bearings can also be supplied with a different internal clearance. Please consult Schaeffler in this case.



Axial internal clearance, preload and preload force of bearing sets with universal bearings in O or X arrangement for tolerance classes Normal, 6, 5

UA = bearing with small axial internal clearance

UB = bearing with smaller axial internal clearance than UA

UO = bearing clearance-free in O or X arrangement

UL = bearing with light preload

Bore code	Axial internal clearance or preload of bearing pair										Preload force	
	Nominal dimension										$F_{V \max}$	
	μm										N	
	UA	UB	UO	UL							UL	
	Bearing series											
	70..-B, 72..-B, 73..-B, 74..-B	70..-B	72..-B	73..-B	74..-B	70..-B	72..-B	73..-B	74..-B			
00	22	14	0	-	-3	-	-	-	38	-	-	
01	24	15	0	-	-4	-5	-	-	53	82	-	
02	24	15	0	-	-4	-5	-	-	62	99	-	
03	24	15	0	-	-4	-6	-	-	77	123	-	
04	28	16	0	-4	-5	-6	-8	103	103	146	258	
05	34	19	0	-4	-4	-6	-8	115	112	200	300	
06	34	19	0	-5	-5	-7	-8	141	157	250	365	
07	40	22	0	-5	-6	-7	-9	172	208	300	462	
08	40	22	0	-5	-6	-8	-10	200	246	385	535	
09	44	24	0	-	-6	-9	-10	-	277	462	600	
10	44	24	0	-	-6	-10	-10	-	288	535	692	
11	46	25	0	-	-7	-10	-11	-	358	600	785	
12	46	25	0	-	-7	-10	-11	-	431	692	877	
13	46	25	0	-	-8	-11	-12	-	492	785	977	
14	50	27	0	-	-8	-11	-12	-	535	877	1154	
15	50	27	0	-	-8	-12	-13	-	523	977	1154	
16	50	27	0	-	-8	-12	-16	-	615	1077	1385	
17	54	31	0	-	-8	-13	-	-	692	1154	-	
18	54	31	0	-	-9	-13	-	-	815	1231	-	
19	54	31	0	-	-10	-14	-	-	892	1331	-	
20	54	31	0	-	-11	-14	-	-	992	1485	-	
21	58	34	0	-	-11	-14	-	-	1100	1538	-	
22	58	34	0	-	-12	-15	-	-	1177	1723	-	
24	58	34	0	-	-12	-16	-	-	1277	1923	-	
26	60	34	0	-	-12	-17	-	-	1431	2115	-	
28	60	34	0	-	-12	-17	-	-	1508	2308	-	
30	60	34	0	-	-13	-18	-	-	1723	2500	-	
32	60	34	0	-	-13	-18	-	-	1815	2769	-	
34	70	40	0	-	-14	-19	-	-	2038	3115	-	

Tolerances for axial internal clearance and preload

Tolerances for axial internal clearance and preload of bearing sets with universal bearings in O and X arrangement ▶ 292 | 4.

4
 Tolerances for axial internal clearance and preload of bearing sets with universal bearings in O or X arrangement

Bore code	Tolerances					
	μm					
	Bearing series					
	70..-B, 72..-B		73..-B		74..-B	
	Tolerance class					
	Normal, 6	5	Normal, 6	5	Normal, 6	5
00 to 07	+8 0	+6 0	+8 0	+6 0	+8 0	+6 0
08 to 09	+8 0	+6 0	+8 0	+6 0	+12 0	+10 0
10 to 11	+8 0	+6 0	+12 0	+10 0	+12 0	+10 0
12 to 34	+12 0	+10 0	+12 0	+10 0	+12 0	+10 0

1.11 Dimensions, tolerances

Dimension standards



The main dimensions of angular contact ball bearings of the basic design correspond to DIN 628-1:2008 and ISO 12044:2014. Nominal dimensions of angular contact ball bearings **▶ 304** | .

Chamfer dimensions



The limiting dimensions for chamfer dimensions correspond to DIN 620-6:2004. Overview and limiting values **▶ 135** | 7.11. Nominal value of chamfer dimension **▶ 304** | .

Tolerances



The tolerances for the dimensional and running accuracy of single row angular contact ball bearings correspond to tolerance class Normal in accordance with ISO 492:2014. Tolerance values in accordance with ISO 492 **▶ 122** | 8.

Tolerances for bearings of universal design

Single row bearings are also available in tolerance class 5

In addition to the tolerance class Normal (no tolerance suffix), angular contact ball bearings of universal designs UA, UB, UO and UL are also available by agreement in tolerance class 5 and, in some cases, in tolerance class 6. Tolerance values in accordance with ISO 492 **▶ 122** | 8 to **▶ 127** | 16. The tolerance suffix for bearings of universal design in tolerance class 5 is then:

- P5-UA, P5-UB, P5-UO, P5-UL.



The bores of bearings of universal design for all tolerance classes are uniformly toleranced to tolerance class 5 (no special suffix). The bearing width for universal bearings is toleranced to ISO 492:2014. For width tolerances **▶ 292** | 5.

5
 Tolerance for ring width in bearings of universal design

Tolerance symbols **▶ 122** |

U = upper limit deviation

L = lower limit deviation

Nominal bore diameter		Width deviation			
d		t _{ΔBs}			
mm		μm			
		Bearings in tolerance class			
		Normal, 6		5	
over	incl.	U	L	U	L
–	50	0	–250	0	–250
50	80	0	–380	0	–250
80	120	0	–380	0	–380
120	180	0	–500	0	–380
180	315	0	–500	0	–500

1.12 Suffixes

6
 Suffixes and corresponding descriptions

For a description of the suffixes used in this chapter ▶ 293|**6** and **medias** interchange ▶ <https://www.schaeffler.de/std/1D52>.

Suffix	Description of suffix	
B	Modified internal construction, nominal contact angle $\alpha = 40^\circ$	Standard
JP	Sheet steel cage	Standard, dependent on bore code
MP	Solid brass cage	
TVH, TVP	Solid cage made from glass fibre reinforced polyamide PA66	
P5	Bearing in tolerance class 5	Special design, available by agreement
2RS	Contact seal on both sides (lip seal)	Standard
UA	Universal design for fitting in pairs, bearing pair has a small axial internal clearance in O and X arrangement	
UB	Universal design for fitting in pairs, bearing pair has a smaller axial internal clearance in O and X arrangement than in UA	
UH	Universal design for fitting in pairs, bearing pair has a high preload in O and X arrangement	Available by agreement
UL	Universal design for fitting in pairs, bearing pair has a light preload in O and X arrangement	Standard
UM	Universal design for fitting in pairs, bearing pair has a moderate preload in O and X arrangement	Available by agreement
UO	Universal design for fitting in pairs, bearing pair is clearance-free in O and X arrangement	Standard
XL	X-life bearing, dependent on bore code and bearing type	Standard

1.13 Structure of bearing designation

9
 Examples of composition of bearing designation

The designation of bearings follows a set model. Examples ▶ 293|**9** and ▶ 294|**10**. The composition of designations is subject to DIN 623-1 ▶ 102|**10**.

9
 Single row angular contact ball bearing of basic design: designation structure

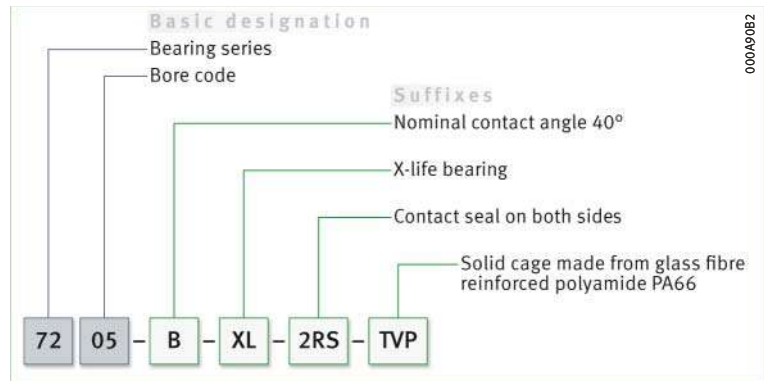

10
Single row angular contact ball bearing of universal design: designation structure

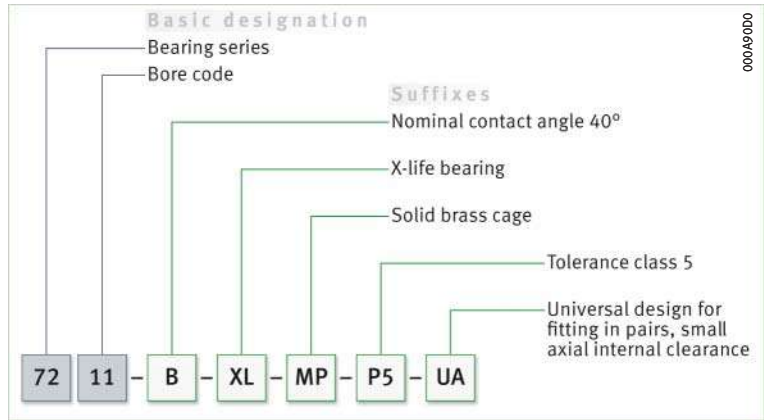

1.14 Dimensioning

$P = F_r$ under purely radial load of constant magnitude and direction

P is a substitute force for combined load and various load cases

$F_a/F_r \leq 1,14$ or $F_a/F_r > 1,14$

Tandem arrangement

Equivalent dynamic bearing load

The basic rating life equation $L = (C_r/P)^P$ used in the dimensioning of bearings under dynamic load assumes a load of constant magnitude and direction. In radial bearings, this is a purely radial load F_r . If this condition is met, the bearing load F_r is used directly in the rating life equation for P ($P = F_r$).

If this condition is not met, a constant radial force must first be determined for the rating life calculation that (in relation to the rating life) represents an equivalent load. This force is known as the equivalent dynamic bearing load P .

The calculation of P is dependent on the load ratio F_a/F_r and the factor 1,14.

For single bearings under dynamic load and bearing pairs in a tandem arrangement \blacktriangleright 294 | $f1$ 1 and \blacktriangleright 294 | $f1$ 2.

$f1$
Equivalent dynamic load

$$\frac{F_a}{F_r} \leq 1,14 \Rightarrow P = F_r$$

$f2$
Equivalent dynamic load

$$\frac{F_a}{F_r} > 1,14 \Rightarrow P = 0,35 \cdot F_r + 0,57 \cdot F_a$$

Legend

P	N	Equivalent dynamic bearing load
F_r	N	Radial load
F_a	N	Resulting axial force \blacktriangleright 295 $f1$ 7. The information in the section "Calculation of internal resulting axial force F_a for single bearings and for bearings in a tandem arrangement" must be taken into consideration when calculating F_a \blacktriangleright 295.

Bearing pairs in O or X arrangement

For bearing pairs under dynamic load in O or X arrangement \blacktriangleright 294 | $f1$ 3 and \blacktriangleright 294 | $f1$ 4.

$f3$
Equivalent dynamic load

$$\frac{F_a}{F_r} \leq 1,14 \Rightarrow P = F_r + 0,55 \cdot F_a$$

$f4$
Equivalent dynamic load

$$\frac{F_a}{F_r} > 1,14 \Rightarrow P = 0,57 \cdot F_r + 0,93 \cdot F_a$$

Legend

P	N	Equivalent dynamic bearing load
F_r	N	Radial load
F_a	N	Resulting axial force \blacktriangleright 294 $f1$ 2 and \blacktriangleright 295 $f1$ 7.

Calculation of internal resulting axial force F_a for single bearings and for bearings in a tandem arrangement

Equations for calculation of internal resulting axial force F_a

Single row angular contact ball bearings transmit radial forces from one raceway to the other oblique to the bearing axis. In the case of a shaft supported by two single row angular contact ball bearings of identical size, the radial load on bearing A therefore leads, due to the inclination of the raceways ($\alpha \neq 0^\circ$), to an axial load on bearing B. The radial load on bearing B also has the effect of an axial load on bearing A; external forces in bearing systems of this type ▶ 295 | 11 and ▶ 295 | 12. This internal resulting axial force F_a must be taken into consideration in the calculation of the equivalent dynamic bearing load P. Equations for calculation of resulting axial force F_a ▶ 295 | 7. The table shows the magnitude of the resulting axial force – that is the sum of or the difference between the internal and external axial force – for bearing arrangements in accordance with ▶ 295 | 11 and ▶ 295 | 12.

Preconditions for calculation

The following applies to the table: the bearing aligned to the external axial force K_a is marked A and the opposing bearing is marked B.

Bearing A is subjected to a radial load F_{rA} , bearing B to a radial load F_{rB} ▶ 295 | 11 and ▶ 295 | 12. F_{rA} and F_{rB} act at the central pressure points of the bearings (dimension a in the product tables) and are always regarded as positive. The bearings are clearance-free, but without preload.

7

Calculation of internal resulting axial force F_a

F_a = internal resulting axial force, which must be used in the calculation of the equivalent dynamic bearing load P.

$$Y_A = Y_B = 0,57$$

Case	Load ratio	External axial force	Resulting axial force F_a	
			Bearing A	Bearing B
1	$\frac{F_{rA}}{Y_A} \leq \frac{F_{rB}}{Y_B}$	$K_a \geq 0$	$F_a = K_a + 0,5 \cdot \frac{F_{rB}}{Y_B}$	F_a is not taken into consideration in the calculation
2	$\frac{F_{rA}}{Y_A} > \frac{F_{rB}}{Y_B}$	$K_a > 0,5 \cdot \left(\frac{F_{rA}}{Y_A} - \frac{F_{rB}}{Y_B} \right)$	$F_a = K_a + 0,5 \cdot \frac{F_{rB}}{Y_B}$	F_a is not taken into consideration in the calculation
3	$\frac{F_{rA}}{Y_A} > \frac{F_{rB}}{Y_B}$	$K_a \leq 0,5 \cdot \left(\frac{F_{rA}}{Y_A} - \frac{F_{rB}}{Y_B} \right)$	F_a is not taken into consideration in the calculation	$F_a = 0,5 \cdot \frac{F_{rA}}{Y_A} - K_a$

11

Adjusted bearing arrangement with two single row angular contact ball bearings in O arrangement, external forces

K_a = external axial force acting on the bearing

F_{rA} = radial load, bearing A

F_{rB} = radial load, bearing B

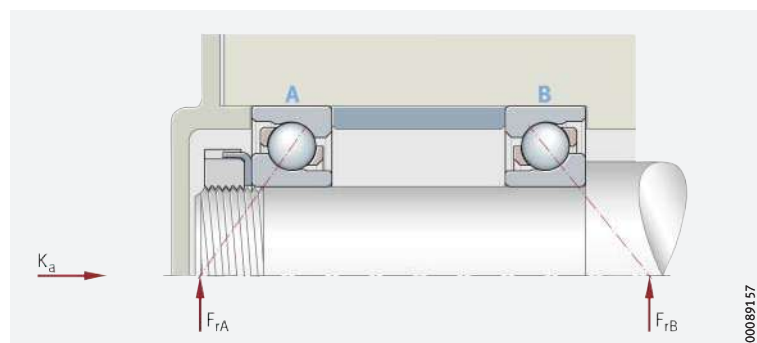

12

Adjusted bearing arrangement with two single row angular contact ball bearings in X arrangement, external forces

K_a = external axial force acting on the bearing

F_{rA} = radial load, bearing A

F_{rB} = radial load, bearing B

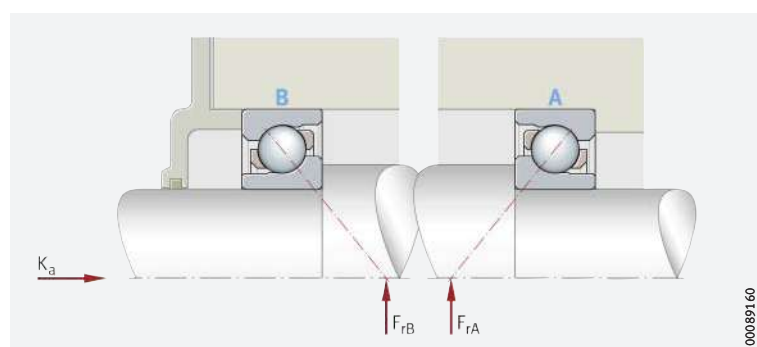

Bearing arrangement for pinion shaft

Example of calculation of internal resulting axial force F_a

Single row angular contact ball bearings are used for the bearing arrangement of a pinion shaft >296| 13. The bearing arrangement should be adjusted and in an O arrangement. In order to calculate the basic rating life, the equivalent dynamic bearing load P must be determined.



Load scheme for pinion shaft

- K_a = external axial force = 6,52 kN
- K_r = external radial force = 0,82 kN
- K_t = tangential force = 5,88 kN

- Resulting radial forces F_r
- Bearing A, F_{rA} = 7,30 kN
- Bearing B, F_{rB} = 2,20 kN

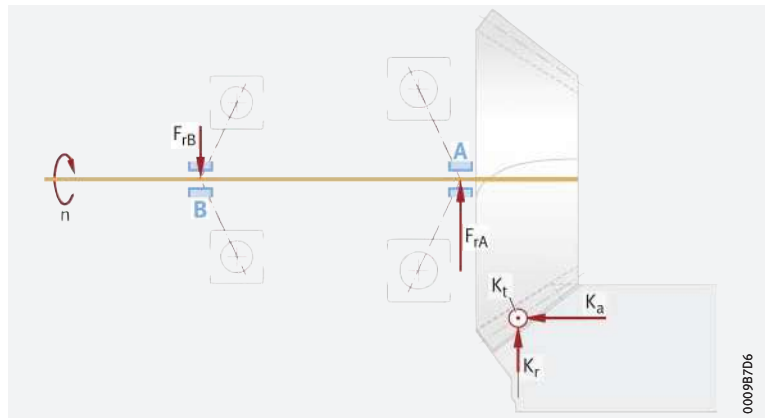

In a bearing arrangement with two single bearings, the resulting axial force F_a must be taken into consideration

Bearing A supports the external axial force K_a . Since this is an adjusted bearing arrangement with two single bearings, the internal resulting axial force F_a in the bearing system must be taken into consideration in the bearing calculation in accordance with >295| 7. For both angular contact ball bearings $Y_A = Y_B = 0,57$. Loads >296| 13.

Step 1

Calculate the load ratio using >296| 5.

5
Load ratio

$$\frac{F_{rA}}{Y_A} > \frac{F_{rB}}{Y_B}$$



$$\frac{7,30 \text{ kN}}{0,57} > \frac{2,20 \text{ kN}}{0,57}$$

Step 2

Compare the result with possible cases >295| 7. Case 2 or case 3 can be considered >296| 8.



8
Calculation of internal resulting axial force F_a

Parameters >294| 2
 $Y_A = Y_B = 0,57$

Case	Load ratio	External axial force	Resulting axial force F_a	
			Bearing A	Bearing B
2	$\frac{F_{rA}}{Y_A} > \frac{F_{rB}}{Y_B}$	$K_a > 0,5 \cdot \left(\frac{F_{rA}}{Y_A} - \frac{F_{rB}}{Y_B} \right)$	$F_a = K_a + 0,5 \cdot \frac{F_{rB}}{Y_B}$	-
3		$K_a \leq 0,5 \cdot \left(\frac{F_{rA}}{Y_A} - \frac{F_{rB}}{Y_B} \right)$	-	$F_a = 0,5 \cdot \frac{F_{rA}}{Y_A} - K_a$

Step 3

Using ▶ 297 | f1 6, check whether case 2 applies ▶ 296 | f1 8.

f1 6
External axial force
in relation to load ratio

$$K_a > 0,5 \left(\frac{F_{rA}}{Y_A} - \frac{F_{rB}}{Y_B} \right)$$



$$\begin{aligned} 6,52 \text{ kN} &> 0,5 \left(\frac{7,30 \text{ kN}}{0,57} - \frac{2,20 \text{ kN}}{0,57} \right) \\ &> 0,5 (12,807 \text{ kN} - 3,859 \text{ kN}) \\ 6,52 \text{ kN} &> 4,474 \text{ kN} \end{aligned}$$

If case 2 applies ▶ 296 | f1 8.

Step 4

Calculating F_a

Using ▶ 297 | f1 7, calculate the internal resulting axial force F_a for bearing A. The calculations are in accordance with ▶ 296 | f1 8, case 2.

f1 7
Internal resulting axial force

$$F_a = K_a + 0,5 \cdot \frac{F_{rB}}{Y_B}$$



$$\begin{aligned} F_a &= 6,52 \text{ kN} + 0,5 \cdot \frac{2,20 \text{ kN}}{0,57} \\ &= 8,45 \text{ kN} \end{aligned}$$

Using value F_a
in the calculation of P

For calculation of the equivalent dynamic bearing load P , the calculated value for F_a in ▶ 294 | f1 2 is then used for bearing A, since $F_a/F_{rA} > 1,14$ ($8,45 \text{ kN}/7,30 \text{ kN} > 1,14$).

Equivalent static bearing load

Tandem arrangement

For single bearings under static load and bearing pairs in a tandem arrangement ▶ 297 | f1 8 and ▶ 297 | f1 9.

f1 8
Equivalent static load

$$\frac{F_{0a}}{F_{0r}} \leq 1,9 \Rightarrow P_0 = F_{0r}$$

f1 9
Equivalent static load

$$\frac{F_{0a}}{F_{0r}} > 1,9 \Rightarrow P_0 = 0,5 \cdot F_{0r} + 0,26 \cdot F_{0a}$$

Legend

P_0	N	Equivalent static bearing load
F_{0r}, F_{0a}	N	Largest radial or axial load present (maximum load).

For bearing pairs under static load in an O or X arrangement ▶ 297 | f1 10.

f1 10
Equivalent static load

$$P_0 = F_{0r} + 0,52 \cdot F_{0a}$$

Legend

P_0	N	Equivalent static bearing load
F_{0r}, F_{0a}	N	Largest radial or axial load present (maximum load).

$$S_0 = C_0/P_0$$

Static load safety factor

In addition to the basic rating life L_{10h} , it is also always necessary to check the static load safety factor $S_0 > 298$ |  11.

 11
Static load safety factor

$$S_0 = \frac{C_0}{P_0}$$

Legend

S_0	–	Static load safety factor
C_0	N	Basic static load rating
P_0	N	Equivalent static bearing load.

1.15

Minimum load

 In order to prevent damage due to slippage, a minimum radial load of $P > C_{0r}/100$ is required

In order that no slippage occurs between the contact partners, the angular contact ball bearings must be constantly subjected to a sufficiently high load. Based on experience, a minimum radial load of the order of $P > C_{0r}/100$ is thus necessary. In most cases, however, the radial load is already higher than the requisite minimum load due to the weight of the supported parts and the external forces.







If the minimum radial load is lower than indicated above, please consult Schaeffler.

1.16

Design of bearing arrangements

 Support bearing rings over their entire circumference and width





In order to allow full utilisation of the load carrying capacity of the bearings and thus also achieve the requisite rating life, the bearing rings must be rigidly and uniformly supported by means of contact surfaces over their entire circumference and over the entire width of the raceway. Support can be provided by means of a cylindrical seating surface. The seating and contact surfaces should not be interrupted by grooves, holes or other recesses. The accuracy of mating parts must meet specific requirements  9 to  300 |  11.

 For secure radial location, tight fits are necessary

Radial location of bearings – fit recommendations







In addition to supporting the rings adequately, the bearings must also be securely located in a radial direction, to prevent creep of the bearing rings on the mating parts under load. This is generally achieved by means of tight fits between the bearing rings and the mating parts. If the rings are not secured adequately or correctly, this can cause severe damage to the bearings and adjacent machine parts. Influencing factors, such as the conditions of rotation, magnitude of the load, internal clearance, temperature conditions, design of the mating parts and the mounting and dismantling options must be taken into consideration in the selection of fits.



If shock type loads occur, tight fits (transition fit or interference fit) are required to prevent the rings from coming loose at any point. Clearance, transition or interference fits  150 |  6 and  158 |  7.





The following information provided in Technical principles must be taken into consideration in the design of bearing arrangements:

- conditions of rotation  145
- tolerance classes for cylindrical shaft seats (radial bearings)  147 |  2
- shaft fits  150
- tolerance classes for bearing seats in housings (radial bearings)  148 |  4
- housing fits  158



 *The bearings must also be securely located in an axial direction*

Axial location of bearings – location methods

As a tight fit alone is not normally sufficient to also locate the bearing rings securely on the shaft and in the housing bore in an axial direction, this must usually be achieved by means of an additional axial location or retention method. The axial location of the bearing rings must be matched to the type of bearing arrangement. Shaft and housing shoulders, housing covers, nuts, spacer rings and retaining rings etc., are fundamentally suitable  11 and  12.

 *A minimum of IT6 should be provided for the shaft seat and a minimum of IT7 for the housing seat*

Dimensional, geometrical and running accuracy of the bearing seats

The accuracy of the bearing seat on the shaft and in the housing should correspond to the accuracy of the bearing used. For single row angular contact ball bearings with the tolerance class Normal, the shaft seat should correspond to a minimum of standard tolerance grade IT6 and the housing seat to a minimum of IT7; with tolerance class 6, the shaft seat should correspond to a minimum of IT5 and the housing seat to IT6. Guide values for the geometrical and positional tolerances of bearing seating surfaces  9, tolerances t_1 to t_3 in accordance with  11. Numerical values for IT grades  10.

 **9**
Guide values for the geometrical and positional tolerances of bearing seating surfaces

Bearing tolerance class		Bearing seating surface	Standard tolerance grades to ISO 286-1 (IT grades)			
to ISO 492	to DIN 620		Diameter tolerance	Roundness tolerance t_1	Parallelism tolerance t_2	Total axial runout tolerance of abutment shoulder t_3
Normal	PN (P0)	Shaft	IT6 (IT5)	Circumferential load IT4/2	Circumferential load IT4/2	IT4
				Point load IT5/2	Point load IT5/2	
		Housing	IT7 (IT6)	Circumferential load IT5/2	Circumferential load IT5/2	IT5
				Point load IT6/2	Point load IT6/2	
6	P6	Shaft	IT5	Circumferential load IT3/2	Circumferential load IT3/2	IT3
				Point load IT4/2	Point load IT4/2	
		Housing	IT6	Circumferential load IT4/2	Circumferential load IT4/2	IT4
				Point load IT5/2	Point load IT5/2	

 **10**
Numerical values for ISO standard tolerances (IT grades) to ISO 286-1:2010

IT grade	Nominal dimension in mm							
	over 3	6	10	18	30	50	80	120
	incl. 6	10	18	30	50	80	120	180
Values in μm								
IT3	2,5	2,5	3	4	4	5	6	8
IT4	4	4	5	6	7	8	10	12
IT5	5	6	8	9	11	13	15	18
IT6	8	9	11	13	16	19	22	25
IT7	12	15	18	21	25	30	35	40



Ra must not be too high

Roughness of cylindrical bearing seats

The roughness of the bearing seats must be matched to the tolerance class of the bearings. The mean roughness value Ra must not be too high, in order to maintain the interference loss within limits. The shafts must be ground, while the bores must be precision turned. Guide values as a function of the IT grade of bearing seating surfaces **▶ 300** | **11**.

11
Roughness values
for cylindrical bearing seating
surfaces – guide values

Nominal diameter of the bearing seat d (D) mm		Recommended mean roughness value for ground bearing seats Ramax µm			
		Diameter tolerance (IT grade)			
over	incl.	IT7	IT6	IT5	IT4
–	80	1,6	0,8	0,4	0,2
80	500	1,6	1,6	0,8	0,4

Mounting dimensions for the contact surfaces of bearing rings

The contact surfaces for the rings must be of sufficient height

The mounting dimensions of the shaft and housing shoulders, and spacer rings etc., must ensure that the contact surfaces for the bearing rings are of sufficient height. However, they must also reliably prevent rotating parts of the bearing from grazing stationary parts. Proven mounting dimensions for the radii and diameters of abutment shoulders **▶ 304** | **11**. These dimensions are limiting dimensions (maximum or minimum dimensions); the actual values should not be higher or lower than specified.



If single row angular contact bearings are mounted in a tandem arrangement, it must be ensured that the end faces of the outer rings in contact with each other have sufficient overlap. In case of doubt, please consult Schaeffler.

Adjustment of bearings

Always adjust single bearings against a second bearing

Single row angular contact ball bearings must always be used with a second bearing or as a bearing set **▶ 300** | **14**. If two individual single row angular contact ball bearings are used, these must be adjusted against each other until the requisite preload or desired clearance is achieved.

Select the adjustment such that full function and operational reliability of the bearings is ensured

The correct adjustment of the bearings has a considerable influence on the function and operational reliability of the bearing arrangement. If the clearance is too large, the load carrying capacity of the bearings will not be fully utilised; if the preload is too high, the increased friction losses will give rise to higher operating temperatures, which will, in turn, have a negative effect on the rating life of the bearings.

14
Adjusted bearing arrangement with two single row angular contact ball bearings

① Angular contact ball bearings mounted in X arrangement

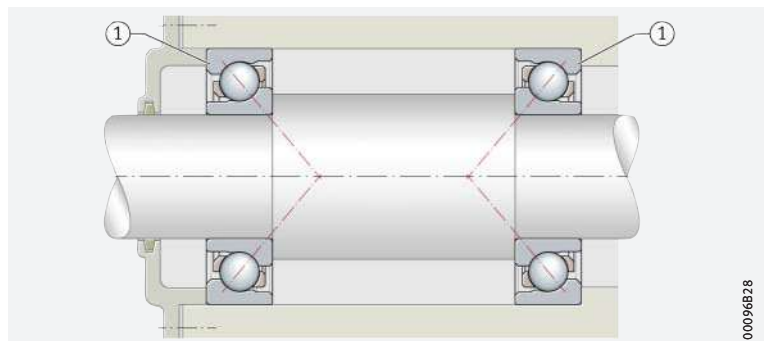

00096B28

☞ *Adjustment not required for bearing sets*

Universal bearings arranged immediately adjacent to each other, or matched bearings, do not need to be adjusted. In such cases, the desired operating clearance or required preload is achieved by selecting the internal clearance or preload class in conjunction with the suitable shaft and housing fits. As a result, particular attention must be paid to the correct selection of internal clearance or preload for these bearing sets.

1.17

Mounting and dismounting



The mounting and dismounting options for angular contact ball bearings, by thermal, hydraulic or mechanical methods, must be taken into consideration in the design of the bearing position.

☞ *Ensure that the bearings are not damaged during mounting*

Single row angular contact ball bearings are not separable. In the mounting of such bearings, the mounting forces must always be applied to the bearing ring with a tight fit.

☞ *Rolling bearings must be handled with great care*

Schaeffler Mounting Handbook

Rolling bearings are well-proven precision machine elements for the design of economical and reliable bearing arrangements, which offer high operational security. In order that these products can function correctly and achieve the envisaged operating life without detrimental effect, they must be handled with care.



The Schaeffler Mounting Handbook MH 1 gives comprehensive information about the correct storage, mounting, dismounting and maintenance of rotary rolling bearings ► <https://www.schaeffler.de/std/1D53>. It also provides information which should be observed by the designer, in relation to the mounting, dismounting and maintenance of bearings, in the original design of the bearing position. This book is available from Schaeffler on request.

1.18

Legal notice regarding data freshness

☞ *The further development of products may also result in technical changes to catalogue products*

Of central interest to Schaeffler is the further development and optimisation of its products and the satisfaction of its customers. In order that you, as the customer, can keep yourself optimally informed about the progress that is being made here and with regard to the current technical status of the products, we publish any product changes which differ from the printed version in our electronic product catalogue.



We therefore reserve the right to make changes to the data and illustrations in this catalogue. This catalogue reflects the status at the time of printing. More recent publications released by us (as printed or digital media) will automatically precede this catalogue if they involve the same subject. Therefore, please always use our electronic product catalogue to check whether more up-to-date information or modification notices exist for your desired product.

Link to electronic product catalogue



The following link will take you to the Schaeffler electronic product catalogue: ► <https://medias.schaeffler.com>.



1.19 Further information



In addition to the data in this chapter, the following chapters in Technical principles must also be observed in the design of bearing arrangements:

- Determining the bearing size ▶ 34
- Rigidity ▶ 54
- Friction and increases in temperature ▶ 56
- Speeds ▶ 64
- Bearing data ▶ 97
- Lubrication ▶ 70
- Sealing ▶ 182
- Design of bearing arrangements ▶ 139
- Mounting and dismounting ▶ 191.





Angular contact ball bearings

Single row

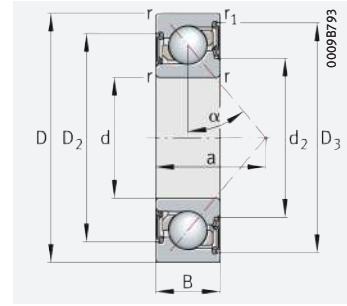
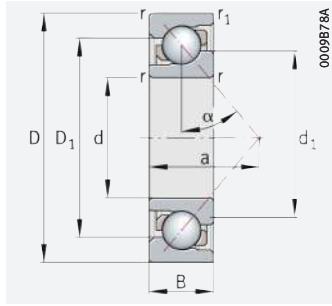

With seal 2RS

d = 10 – 20 mm

Main dimensions			Basic load ratings		Fatigue limit load C_{ur} N	Limiting speed n_G min^{-1}	Speed rating $n_{\partial r}$ min^{-1}	Mass m \approx kg	Designation ▶ 293 1.12 ▶ 293 1.13 X-life ▶ 285
d	D	B	dyn. C_r N	stat. C_{0r} N					
10	30	9	5 300	2 600	174	34 500	22 600	0,033	7200-B-XL-JP
	30	9	5 300	2 600	174	34 500	22 600	0,032	7200-B-XL-TVP
	30	9	5 300	2 600	174	16 100	–	0,037	7200-B-XL-2RS-TVP
12	32	10	7 400	3 550	241	30 000	21 100	0,037	7201-B-XL-JP
	32	10	7 400	3 550	241	30 000	21 100	0,038	7201-B-XL-TVP
	32	10	7 400	3 550	241	14 800	–	0,037	7201-B-XL-2RS-TVP
	37	12	11 400	5 300	355	25 500	16 300	0,066	7301-B-XL-JP
	37	12	11 400	5 300	355	25 500	16 300	0,06	7301-B-XL-TVP
15	35	11	8 400	4 450	300	27 000	19 100	0,045	7202-B-XL-JP
	35	11	8 400	4 450	300	27 000	19 100	0,044	7202-B-XL-TVP
	35	11	8 400	4 450	300	12 800	–	0,048	7202-B-XL-2RS-TVP
	42	13	14 200	7 200	485	22 200	14 200	0,084	7302-B-XL-JP
	42	13	14 200	7 200	485	22 200	14 200	0,081	7302-B-XL-TVP
17	42	13	14 200	7 200	485	11 100	–	0,082	7302-B-XL-2RS-TVP
	40	12	10 500	5 700	380	23 400	17 100	0,067	7203-B-XL-JP
	40	12	10 500	5 700	380	23 400	17 100	0,065	7203-B-XL-TVP
	40	12	10 500	5 700	380	11 100	–	0,068	7203-B-XL-2RS-TVP
	47	14	17 600	9 000	610	19 600	12 800	0,117	7303-B-XL-JP
20	47	14	17 600	9 000	610	19 600	12 800	0,11	7303-B-XL-TVP
	47	14	17 600	9 000	610	9 800	–	0,112	7303-B-XL-2RS-TVP
	42	12	14 500	8 000	540	20 500	14 400	0,061	7004-B-XL-TVP
20	42	12	14 500	8 000	540	9 800	–	0,061	7004-B-XL-2RS-TVP
	47	14	14 000	7 800	520	19 700	15 400	0,106	7204-B-XL-JP
	47	14	14 000	7 800	520	19 700	15 400	0,103	7204-B-XL-TVP
	47	14	14 000	7 800	520	9 500	–	0,107	7204-B-XL-2RS-TVP
	52	15	20 400	11 100	750	17 600	11 500	0,149	7304-B-XL-JP
	52	15	20 400	11 100	750	17 600	11 500	0,147	7304-B-XL-TVP
	52	15	20 400	11 100	750	8 600	–	0,147	7304-B-XL-2RS-TVP

medias ▶ <https://www.schaeffler.de/std/1DED>

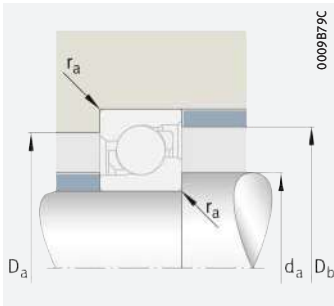

Mounting dimensions

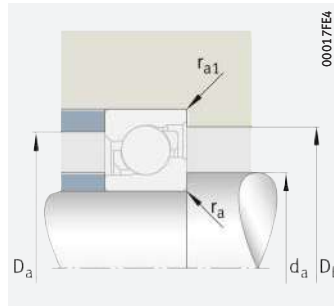

Mounting dimensions



Dimensions										Nominal contact angle	Mounting dimensions				
d	r	r ₁	D ₁	D ₂	D ₃	d ₁	d ₂	a	α		d _a	D _a	D _b	r _a	r _{a1}
	min.	min.	≈	≈	≈	≈	≈	≈	°	min.	max.	max.	max.	max.	
10	0,6	0,3	22	–	–	18,3	–	13	40	14,2	25,8	27,6	0,6	0,3	
	0,6	0,3	22	–	–	18,3	–	13	40	14,2	25,8	27,6	0,6	0,3	
	0,6	0,3	22	23,2	25,4	–	15,5	13	40	14,2	25,8	27,6	0,6	0,3	
12	0,6	0,3	24,6	–	–	19,8	–	14	40	16,2	27,8	29,6	0,6	0,3	
	0,6	0,3	24,6	–	–	19,8	–	14	40	16,2	27,8	29,6	0,6	0,3	
	0,6	0,3	24,6	25,9	28,8	–	17	14	40	16,2	27,8	29,6	0,6	0,3	
	1	0,6	27,2	–	–	22,3	–	16	40	17,6	31,4	32,8	1	0,6	
	1	0,6	27,2	–	–	22,3	–	16	40	17,6	31,4	32,8	1	0,6	
15	0,6	0,3	27,6	–	–	22,8	–	16	40	19,2	30,8	32,6	0,6	0,3	
	0,6	0,3	27,6	–	–	22,8	–	16	40	19,2	30,8	32,6	0,6	0,3	
	0,6	0,3	27,6	29,2	32,1	–	19,7	16	40	19,2	30,8	32,6	0,6	0,3	
	1	0,6	31,7	–	–	26	–	18	40	20,6	36,4	37,8	1	0,6	
	1	0,6	31,7	–	–	26	–	18	40	20,6	36,4	37,8	1	0,6	
	1	0,6	31,7	33,3	38,1	–	22,9	18	40	20,6	36,4	37,8	1	0,6	
17	0,6	0,3	31,5	–	–	26	–	18	40	21,2	35,8	37,6	0,6	0,6	
	0,6	0,3	31,5	–	–	26	–	18	40	21,2	35,8	37,6	0,6	0,6	
	0,6	0,3	31,5	33,1	36,3	–	22,9	18	40	21,2	35,8	37,6	0,6	0,6	
	1	0,6	35,5	–	–	29,2	–	20	40	22,6	41,4	42,8	1	0,6	
	1	0,6	35,5	–	–	29,2	–	20	40	22,6	41,4	42,8	1	0,6	
	1	0,6	35,5	37,2	42,6	–	26,1	20	40	22,6	41,4	42,8	1	0,6	
20	0,6	0,3	34,8	–	–	28,9	–	12	40	23,2	38,8	40	0,6	0,3	
	0,6	0,3	34,8	35,5	39,8	–	26,5	12	40	23,2	38,8	40	0,6	0,3	
	1	0,6	37	–	–	30,5	–	21	40	25,6	41,4	42,8	1	0,6	
	1	0,6	37	–	–	30,5	–	21	40	25,6	41,4	42,8	1	0,6	
	1	0,6	37	39,2	43	–	26,8	21	40	25,6	41,4	42,8	1	0,6	
	1,1	0,6	39,7	–	–	33	–	23	40	27	45	47,8	1	0,6	
	1,1	0,6	39,7	–	–	33	–	23	40	27	45	47,8	1	0,6	
	1,1	0,6	39,7	41,4	47,1	–	30	23	40	27	45	47,8	1	0,6	



Angular contact ball bearings

Single row

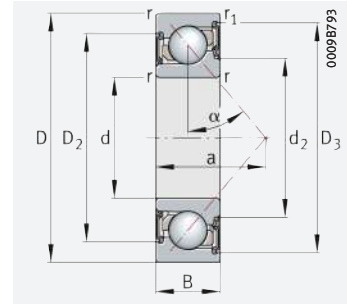
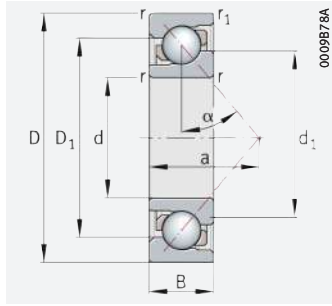

With seal 2RS

d = 25 – 35 mm

Main dimensions			Basic load ratings		Fatigue limit load C_{ur}	Limiting speed n_G	Speed rating n_{dr}	Mass m	Designation
d	D	B	dyn. C_r	stat. C_{0r}					
			N	N	N	min^{-1}	min^{-1}	≈ kg	
25	47	12	16 000	9 900	670	18 100	12 000	0,071	7005-B-XL-TVP
	47	12	16 000	9 900	670	7 900	–	0,071	7005-B-XL-2RS-TVP
	52	15	15 300	9 000	600	17 400	13 700	0,13	7205-B-XL-JP
	52	15	15 300	9 000	600	17 400	13 700	0,127	7205-B-XL-TVP
	52	15	15 300	9 000	600	8 000	–	0,132	7205-B-XL-2RS-TVP
	62	17	28 000	15 800	1 070	14 300	9 800	0,242	7305-B-XL-JP
	62	17	28 000	15 800	1 070	14 300	9 800	0,223	7305-B-XL-TVP
	62	17	28 000	15 800	1 070	7 100	–	0,231	7305-B-XL-2RS-TVP
	80	21	43 500	26 000	1 750	15 100	7 500	0,585	7405-B-XL-MP
30	42	7	5 600	4 550	295	20 600	9 600	0,026	71806-B-TVH
	55	13	19 900	13 400	900	15 200	10 200	0,109	7006-B-XL-TVP
	55	13	19 900	13 400	900	6 500	–	0,109	7006-B-XL-2RS-TVP
	62	16	21 700	14 100	950	14 400	11 200	0,203	7206-B-XL-JP
	62	16	21 700	14 100	950	14 400	11 200	0,197	7206-B-XL-TVP
	62	16	21 700	14 100	950	6 500	–	0,204	7206-B-XL-2RS-TVP
	72	19	35 500	22 100	1 490	12 300	8 600	0,362	7306-B-XL-JP
	72	19	35 500	22 100	1 490	12 300	8 600	0,341	7306-B-XL-TVP
	72	19	35 500	22 100	1 490	6 000	–	0,341	7306-B-XL-2RS-TVP
	90	23	51 000	30 500	2 050	13 100	6 800	0,791	7406-B-XL-MP
35	47	7	6 000	5 300	350	18 100	8 200	0,029	71807-B-TVH
	62	14	24 300	17 200	1 160	13 400	9 000	0,14	7007-B-XL-TVP
	62	14	24 300	17 200	1 160	6 000	–	0,14	7007-B-XL-2RS-TVP
	72	17	28 000	19 000	1 280	12 200	9 600	0,29	7207-B-XL-JP
	72	17	28 000	19 000	1 280	12 200	9 600	0,282	7207-B-XL-TVP
	72	17	28 000	19 000	1 280	5 600	–	0,292	7207-B-XL-2RS-TVP
	80	21	43 000	27 500	1 860	10 800	7 900	0,48	7307-B-XL-JP
	80	21	43 000	27 500	1 860	10 800	7 900	0,48	7307-B-XL-TVP
	80	21	43 000	27 500	1 860	5 300	–	0,477	7307-B-XL-2RS-TVP
	100	25	65 000	43 000	2 900	11 000	5 400	1,014	7407-B-XL-MP

medias ► <https://www.schaeffler.de/std/1DEE>

► 293 | 1.12
 ► 293 | 1.13
 X-life ► 285

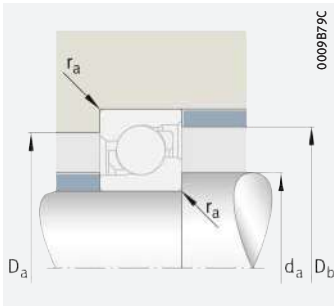

Mounting dimensions

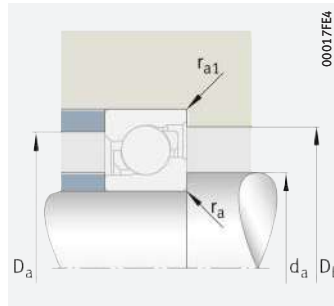

Mounting dimensions



Dimensions										Mounting dimensions				
d	r	r ₁	D ₁	D ₂	D ₃	d ₁	d ₂	a	Nominal contact angle α	d _a	D _a	D _b	r _a	r _{a1}
	min.	min.	≈	≈	≈	≈	≈	≈	°	min.	max.	max.	max.	max.
25	0,6	0,3	39,8	–	–	33,9	–	21	40	28,2	43,8	45	0,6	0,3
	0,6	0,3	39,8	40,5	44,8	–	31,5	21	40	28,2	43,8	45	0,6	0,3
	1	0,6	42	–	–	35,5	–	24	40	30,6	46,4	47,8	1	0,6
	1	0,6	42	–	–	35,5	–	24	40	30,6	46,4	47,8	1	0,6
	1	0,6	42	44,1	48	–	31,8	24	40	30,6	46,4	47,8	1	0,6
	1,1	0,6	48	–	–	39,9	–	27	40	32	55	57,8	1	0,6
	1,1	0,6	48	–	–	39,9	–	27	40	32	55	57,8	1	0,6
	1,1	0,6	48	50,3	57,1	–	36,2	27	40	32	55	57,8	1	0,6
30	1,5	1	57,9	–	–	48,2	–	33	40	36	69	74,4	1,5	1
	0,3	0,2	37,3	–	–	34,7	–	18,6	40	32	40	40	0,3	0,2
	1	0,6	47,1	–	–	41,3	–	24	40	34,6	50,4	51,8	1	0,6
	1	0,6	47,1	47,7	51,9	–	38	24	40	34,6	50,4	51,8	1	0,6
	1	0,6	49,5	–	–	43,2	–	27	40	35,6	56,4	57,8	1	0,6
	1	0,6	49,5	–	–	43,2	–	27	40	35,6	56,4	57,8	1	0,6
	1	0,6	49,5	51,7	57,1	–	39,5	27	40	35,6	56,4	57,8	1	0,6
	1,1	0,6	55,9	–	–	47,1	–	31	40	37	65	67,8	1	0,6
35	1,1	0,6	55,9	–	–	47,1	–	31	40	37	65	67,8	1	0,6
	1,1	0,6	55,9	58,5	65,9	–	42,7	31	40	37	65	67,8	1	0,6
	1,5	1	66	–	–	55,3	–	37	40	41	79	84,4	1,5	1
	0,3	0,2	42,3	–	–	39,7	–	20,7	40	37	45	45,6	0,3	0,2
	1	0,6	53,4	–	–	47	–	27	40	39,6	57,4	58,8	1	0,6
	1	0,6	53,4	54	58,9	–	43,6	27	40	39,6	57,4	58,8	1	0,6
	1,1	0,6	57,6	–	–	50,2	–	31	40	42	65	67,8	1	0,6
	1,1	0,6	57,6	–	–	50,2	–	31	40	42	65	67,8	1	0,6
35	1,1	0,6	57,6	60,2	66,5	–	45,8	31	40	42	65	67,8	1	0,6
	1,5	1	63	–	–	53,1	–	35	40	44	71	74,4	1,5	1
	1,5	1	63	–	–	53,1	–	35	40	44	71	74,4	1,5	1
	1,5	1	63	65,6	73,9	–	48,7	35	40	44	71	74,4	1,5	1
	1,5	1	79,8	–	–	66,7	–	41	40	46	94,4	100	1,5	1



Angular contact ball bearings

Single row

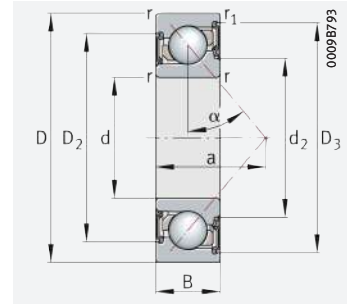
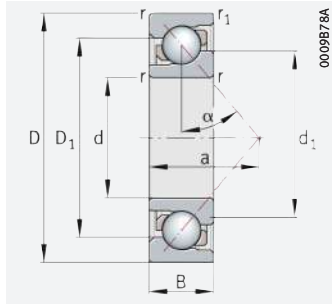

With seal 2RS

d = 40 – 55 mm

Main dimensions			Basic load ratings		Fatigue limit load	Limiting speed	Speed rating	Mass	Designation
d	D	B	dyn. C _r	stat. C _{0r}	C _{ur}	n _G	n _{Dr}	m	▶ 293 1.12 ▶ 293 1.13 X-life ▶ 285
			N	N	N	min ⁻¹	min ⁻¹	≈ kg	
40	52	7	6 300	5 800	395	16 200	7 200	0,033	71808-B-TVH
	68	15	28 000	20 300	1 370	12 100	8 400	0,176	7008-B-XL-TVP
	68	15	28 000	20 300	1 370	5 200	–	0,17	7008-B-XL-2RS-TVP
	80	18	34 000	23 500	1 580	10 900	8 600	0,372	7208-B-XL-JP
	80	18	34 000	23 500	1 580	10 900	8 600	0,367	7208-B-XL-TVP
	80	18	34 000	23 500	1 580	5 000	–	0,379	7208-B-XL-2RS-TVP
	90	23	53 000	34 500	2 320	9 500	7 100	0,646	7308-B-XL-JP
	90	23	53 000	34 500	2 320	9 500	7 100	0,61	7308-B-XL-TVP
	90	23	53 000	34 500	2 320	4 650	–	0,61	7308-B-XL-2RS-TVP
	110	27	75 000	50 000	3 400	9 900	5 000	1,338	7408-B-XL-MP
45	58	7	6 600	6 500	450	14 500	6 300	0,041	71809-B-TVH
	85	19	37 500	27 000	1 810	10 000	8 000	0,411	7209-B-XL-JP
	85	19	37 500	27 000	1 810	10 000	8 000	0,405	7209-B-XL-TVP
	85	19	37 500	27 000	1 810	4 550	–	0,405	7209-B-XL-2RS-TVP
	100	25	65 000	43 000	2 900	8 400	6 500	0,937	7309-B-XL-JP
	100	25	65 000	43 000	2 900	8 400	6 500	0,937	7309-B-XL-TVP
	120	29	86 000	61 000	4 100	9 100	4 650	1,684	7409-B-XL-MP
50	65	7	7 000	7 400	520	12 900	5 400	0,058	71810-B-TVH
	90	20	39 000	28 500	1 920	9 300	7 600	0,466	7210-B-XL-JP
	90	20	39 000	28 500	1 920	9 300	7 600	0,456	7210-B-XL-TVP
	90	20	39 000	28 500	1 920	4 200	–	0,468	7210-B-XL-2RS-TVP
	110	27	75 000	50 000	3 400	7 600	6 100	1,13	7310-B-XL-JP
	110	27	75 000	50 000	3 400	7 600	6 100	1,05	7310-B-XL-TVP
	130	31	96 000	69 000	4 650	8 300	4 400	2,054	7410-B-XL-MP
55	72	9	11 800	11 800	760	11 400	5 600	0,084	71811-B-TVH
	100	21	49 000	38 500	2 600	8 300	6 800	0,645	7211-B-XL-JP
	100	21	49 000	38 500	2 600	8 300	6 800	0,604	7211-B-XL-TVP
	120	29	86 000	61 000	4 100	7 000	5 600	1,46	7311-B-XL-JP
	120	29	86 000	61 000	4 100	7 000	5 600	1,38	7311-B-XL-TVP
	140	33	110 000	82 000	5 400	7 700	4 150	2,64	7411-B-XL-MP

medias ▶ <https://www.schaeffler.de/std/1DEF>

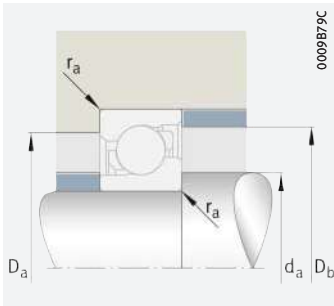

Mounting dimensions

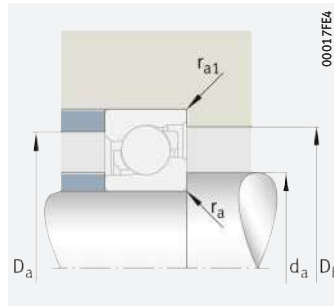

Mounting dimensions



Dimensions										Mounting dimensions				
d	r	r ₁	D ₁	D ₂	D ₃	d ₁	d ₂	a	Nominal contact angle α	d _a	D _a	D _b	r _a	r _{a1}
	min.	min.	≈	≈	≈	≈	≈	≈	°	min.	max.	max.	max.	max.
40	0,3	0,2	47,3	–	–	44,7	–	22,8	40	42	50	50	0,3	0,2
	1	0,6	58,8	–	–	51,9	–	30	40	44,6	63,4	64,8	1	0,6
	1	0,6	58,8	59,4	65	–	48,3	30	40	44,6	63,4	64,8	1	0,6
	1,1	0,6	64,4	–	–	56,4	–	34	40	47	73	75,8	1	0,6
	1,1	0,6	64,4	–	–	56,4	–	34	40	47	73	75,8	1	0,6
	1,1	0,6	64,4	67	73,8	–	52	34	40	47	73	75,8	1	0,6
	1,5	1	71,3	–	–	60	–	39	40	49	81	84,4	1,5	1
	1,5	1	71,3	–	–	60	–	39	40	49	81	84,4	1,5	1
	1,5	1	71,3	73,9	83,3	–	55,6	39	40	49	81	84,4	1,5	1
2	1	87,6	–	–	73,1	–	45	40	53	97	104,4	2	1	
45	0,3	0,2	52,8	–	–	50,2	–	25,1	40	47	56	56	0,3	0,2
	1,1	0,6	69,8	–	–	61,2	–	37	40	52	78	80,8	1	0,6
	1,1	0,6	69,8	–	–	61,2	–	37	40	52	78	80,8	1	0,6
	1,1	0,6	69,8	72,4	79,6	–	56,8	37	40	52	78	80,8	1	0,6
	1,5	1	79,8	–	–	66,7	–	43	40	54	91	94,4	1,5	1
	1,5	1	79,8	–	–	66,7	–	43	40	54	91	94,4	1,5	1
2	1	95,3	–	–	80,3	–	49	40	58	107	114,4	2	1	
50	0,3	0,2	59,3	–	–	56,7	–	27,8	40	52	63	63	0,3	0,2
	1,1	0,6	74,8	–	–	66,3	–	39	40	57	83	85,8	1	0,6
	1,1	0,6	74,8	–	–	66,3	–	39	40	57	83	85,8	1	0,6
	1,1	0,6	74,8	77,4	84,6	–	61,8	39	40	57	83	85,8	1	0,6
	2	1	87,6	–	–	73,1	–	47	40	61	99	104,4	2	1
	2	1	87,6	–	–	73,1	–	47	40	61	99	104,4	2	1
	2,1	1,1	103,4	–	–	87,3	–	53	40	64	116	121	2,1	1
55	0,3	0,2	65,3	–	–	61,7	–	31,1	40	57	70	70	0,3	0,2
	1,5	1	83	–	–	72,6	–	43	40	64	91	94,4	1,5	1
	1,5	1	83	–	–	72,6	–	43	40	64	91	94,4	1,5	1
	2	1	95,3	–	–	80,3	–	51	40	66	109	114,4	2	1
	2	1	95,3	–	–	80,3	–	51	40	66	109	114,4	2	1
	2,1	1,1	111,5	–	–	95,3	–	57	40	69	126	131	2,1	1

Angular contact ball bearings

Single row

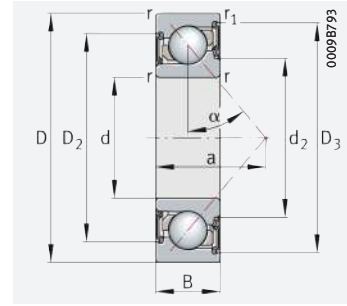
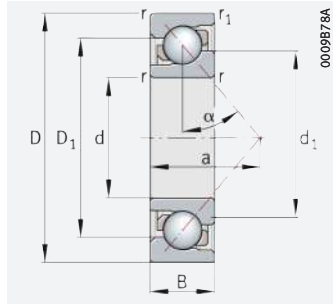

With seal 2RS

d = 60 – 80 mm

Main dimensions			Basic load ratings		Fatigue limit load	Limiting speed	Speed rating	Mass	Designation
d	D	B	dyn. C _r	stat. C _{0r}	C _{ur}	n _G	n _{0r}	m	▶ 293 1.12 ▶ 293 1.13 X-life ▶ 285
			N	N	N	min ⁻¹	min ⁻¹	≈ kg	
60	78	10	12 300	12 800	840	10 500	5 400	0,11	71812-B-TVH
	110	22	59 000	45 000	3 050	7 500	6 200	0,782	7212-B-XL-JP
	110	22	59 000	45 000	3 050	7 500	6 200	0,808	7212-B-XL-TVP
	110	22	59 000	45 000	3 050	3 450	–	0,78	7212-B-XL-2RS-TVP
	130	31	96 000	69 000	4 650	6 400	5 300	1,74	7312-B-XL-JP
	130	31	96 000	69 000	4 650	6 400	5 300	1,71	7312-B-XL-TVP
150	35	126 000	93 000	6 000	7 100	3 950	3,106	7412-B-XL-MP	
65	85	10	15 200	15 800	970	9 600	4 850	0,13	71813-B-TVH
	120	23	67 000	55 000	3 700	6 900	5 700	1,08	7213-B-XL-JP
	120	23	67 000	55 000	3 700	6 900	5 700	1	7213-B-XL-TVP
	140	33	110 000	82 000	5 400	5 900	5 000	2,22	7313-B-XL-JP
	140	33	110 000	82 000	5 400	5 900	5 000	2,12	7313-B-XL-TVP
	160	37	140 000	107 000	6 700	6 600	3 800	3,709	7413-B-XL-MP
70	90	10	15 800	17 200	1 070	9 000	4 500	0,14	71814-B-TVH
	125	24	74 000	62 000	4 200	6 500	5 400	1,17	7214-B-XL-JP
	125	24	74 000	62 000	4 200	6 500	5 400	1,08	7214-B-XL-TVP
	125	24	74 000	62 000	4 200	3 000	–	1,081	7214-B-XL-2RS-TVP
	150	35	126 000	93 000	6 000	5 500	4 750	2,76	7314-B-XL-JP
	150	35	126 000	93 000	6 000	5 500	4 750	2,58	7314-B-XL-TVP
	180	42	167 000	138 000	8 100	5 800	3 450	5,386	7414-B-XL-MP
75	95	10	16 200	18 100	1 140	8 500	4 150	0,15	71815-B-TVH
	130	25	73 000	62 000	4 100	6 300	5 300	1,25	7215-B-XL-JP
	130	25	73 000	62 000	4 100	6 300	5 300	1,16	7215-B-XL-TVP
	160	37	140 000	107 000	6 700	5 100	4 500	3,29	7315-B-XL-JP
	160	37	140 000	107 000	6 700	5 100	4 500	3,1	7315-B-XL-TVP
	190	45	167 000	138 000	8 100	5 800	3 750	6,7	7415-B-XL-MP
80	100	10	16 500	19 100	1 200	8 000	3 900	0,155	71816-B-TVH
	140	26	85 000	72 000	4 650	5 800	4 950	1,53	7216-B-XL-JP
	140	26	85 000	72 000	4 650	5 800	4 950	1,42	7216-B-XL-TVP
	170	39	155 000	124 000	7 500	4 750	4 250	3,86	7316-B-XL-JP
	170	39	155 000	124 000	7 500	4 750	4 250	3,66	7316-B-XL-TVP
	200	48	200 000	169 000	9 600	5 300	3 600	7,477	7416-B-XL-MP

medias ▶ <https://www.schaeffler.de/std/1DF0>

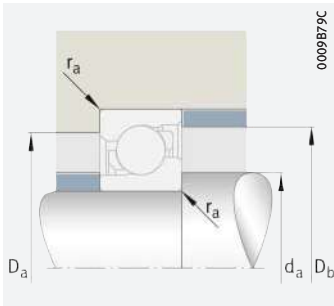

Mounting dimensions

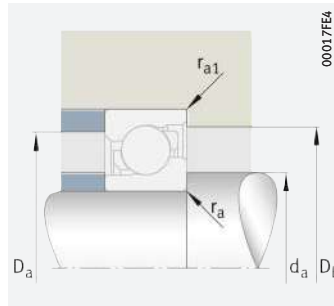

Mounting dimensions



Dimensions										Nominal contact angle α	Mounting dimensions				
d	r	r ₁	D ₁	D ₂	D ₃	d ₁	d ₂	a	α		d _a	D _a	D _b	r _a	r _{a1}
	min.	min.	≈	≈	≈	≈	≈	≈	°		min.	max.	max.	max.	max.
60	0,3	0,2	70,8	-	-	-	67,2	-	33,9	40	62	76	76,6	0,3	0,2
	1,5	1	90,8	-	-	-	80,3	-	47	40	69	101	104,4	1,5	1
	1,5	1	90,8	-	-	-	80,3	-	47	40	69	101	104,4	1,5	1
	1,5	1	90,8	94,4	103,4	-	75,3	47	40	40	69	101	104,4	1,5	1
	2,1	1,1	103,4	-	-	-	87,3	-	55	40	72	118	123	2,1	1
	2,1	1,1	103,4	-	-	-	87,3	-	55	40	72	118	123	2,1	1
	2,1	1,1	119,6	-	-	-	102,3	-	62	40	74	136	141	2,1	1
65	0,6	0,3	77	-	-	-	73	-	36,5	40	68,2	81,8	83	0,6	0,3
	1,5	1	98,9	-	-	-	86,3	-	51	40	74	111	114,4	1,5	1
	1,5	1	98,9	-	-	-	86,3	-	51	40	74	111	114,4	1,5	1
	2,1	1,1	111,5	-	-	-	95,3	-	60	40	77	128	133	2,1	1
	2,1	1,1	111,5	-	-	-	95,3	-	60	40	77	128	133	2,1	1
	2,1	1,1	128	-	-	-	109,2	-	66	40	79	146	151	2,1	1
70	0,6	0,3	82	-	-	-	78	-	38,5	40	73,2	86,8	88	0,6	0,3
	1,5	1	104	-	-	-	92,3	-	53	40	79	116	119,4	1,5	1
	1,5	1	104	-	-	-	92,3	-	53	40	79	116	119,4	1,5	1
	1,5	1	104	107,6	117,9	-	87,3	53	40	40	79	116	119,4	1,5	1
	2,1	1,1	119,6	-	-	-	102,3	-	64	40	82	138	143	2,1	1
	2,1	1,1	119,6	-	-	-	102,3	-	64	40	82	138	143	2,1	1
	3	1,1	144,3	-	-	-	123,1	-	73	40	86	164	171	2,5	1
75	0,6	0,3	87	-	-	-	83	-	40,7	40	78,2	91,8	93	0,6	0,3
	1,5	1	109,2	-	-	-	96,5	-	56	40	84	121	124,4	1,5	1
	1,5	1	109,2	-	-	-	96,5	-	56	40	84	121	124,4	1,5	1
	2,1	1,1	128	-	-	-	109,2	-	68	40	87	148	153	2,1	1
	2,1	1,1	128	-	-	-	109,2	-	68	40	87	148	153	2,1	1
	3	1,1	144,3	-	-	-	123,1	-	78	40	91	174	181	2,5	1
80	0,6	0,3	92	-	-	-	88	-	42,8	40	85,2	96,8	98	0,6	0,3
	2	1	117,2	-	-	-	102,9	-	59	40	91	129	134,4	2	1
	2	1	117,2	-	-	-	102,9	-	59	40	91	129	134,4	2	1
	2,1	1,1	136,7	-	-	-	115,7	-	72	40	92	158	163	2,1	1
	2,1	1,1	136,7	-	-	-	115,7	-	72	40	92	158	163	2,1	1
	3	1,1	153,9	-	-	-	129	-	83	40	96	184	191	2,5	1

Angular contact ball bearings

Single row

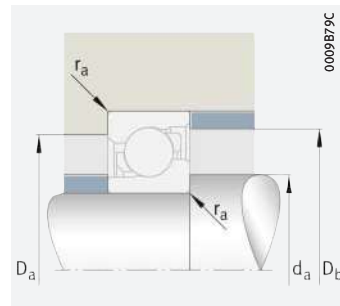
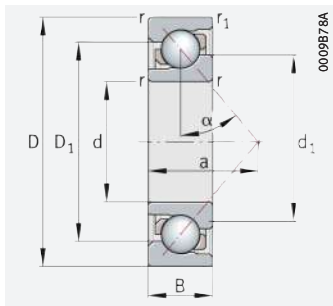

Mounting dimensions

d = 85 – 180 mm

Main dimensions			Basic load ratings		Fatigue limit load C_{ur} N	Limiting speed n_G min^{-1}	Speed rating n_{dr} min^{-1}	Mass m \approx kg	Designation
d	D	B	dyn. C_r N	stat. C_{0r} N					
85	150	28	97 000	86 000	5 300	5 400	4 750	1,94	7217-B-XL-JP
	150	28	97 000	86 000	5 300	5 400	4 750	1,82	7217-B-XL-TVP
	180	41	167 000	138 000	8 100	4 450	4 100	4,4	7317-B-XL-JP
	180	41	167 000	138 000	8 100	4 450	4 100	4,26	7317-B-XL-TVP
90	160	30	114 000	98 000	5 900	5 000	4 550	2,38	7218-B-XL-JP
	160	30	114 000	98 000	5 900	5 000	4 550	2,21	7218-B-XL-TVP
	190	43	180 000	155 000	8 800	4 200	3 900	5,14	7318-B-XL-JP
	190	43	180 000	155 000	8 800	4 200	3 900	5	7318-B-XL-TVP
95	170	32	123 000	106 000	6 200	4 700	4 450	2,64	7219-B-XL-TVP
	200	45	189 000	167 000	9 300	4 000	3 800	5,93	7319-B-XL-JP
	200	45	189 000	167 000	9 300	4 000	3 800	5,78	7319-B-XL-TVP
100	180	34	148 000	132 000	7 500	4 400	4 200	3,45	7220-B-XL-JP
	180	34	142 000	124 000	7 100	4 400	4 250	3,17	7220-B-XL-TVP
	215	47	214 000	197 000	10 600	3 700	3 550	7,38	7320-B-XL-JP
	215	47	214 000	197 000	10 600	3 700	3 550	7,16	7320-B-XL-TVP
105	190	36	155 000	142 000	7 900	5 400	4 100	4,18	7221-B-XL-MP
	225	49	225 000	214 000	11 200	4 600	3 400	9,3	7321-B-XL-MP
110	200	38	167 000	154 000	8 300	3 950	3 950	4,7	7222-B-XL-JP
	200	38	167 000	154 000	8 300	3 950	3 950	4,44	7222-B-XL-TVP
	240	50	250 000	245 000	12 500	3 300	3 150	9,97	7322-B-XL-JP
	240	50	250 000	245 000	12 500	3 300	3 150	9,74	7322-B-XL-TVP
120	215	40	182 000	178 000	9 300	3 650	3 700	5,4	7224-B-XL-TVP
	260	55	275 000	285 000	13 900	3 050	2 850	12,52	7324-B-XL-TVP
130	230	40	200 000	204 000	10 300	3 400	3 350	6,12	7226-B-XL-TVP
	280	58	305 000	325 000	15 400	2 800	2 600	15,1	7326-B-XL-TVP
140	250	42	214 000	231 000	11 100	4 050	3 100	8,55	7228-B-XL-MP
	300	62	310 000	375 000	12 700	3 350	2 400	20,5	7328-B-MP
150	270	45	245 000	275 000	12 800	3 750	2 850	10,9	7230-B-XL-MP
	320	65	340 000	430 000	14 200	3 150	2 200	24,8	7330-B-MP
160	290	48	241 000	305 000	10 400	3 500	2 650	13,5	7232-B-MP
170	310	52	270 000	355 000	11 600	3 250	2 440	16,7	7234-B-MP
180	320	52	280 000	380 000	12 100	3 100	2 290	17,503	7236-B-MP

medias ► <https://www.schaeffler.de/std/1DF1>

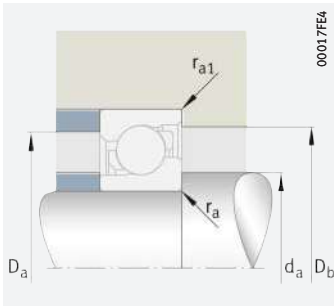

Mounting dimensions



Dimensions						Nominal contact angle	Mounting dimensions				
d	r	r ₁	D ₁	d ₁	a		α	d _a	D _a	D _b	r _a
	min.	min.	≈	≈	≈	°	min.	max.	max.	max.	max.
85	2	1	125	110,6	63	40	96	139	144,4	2	1
	2	1	125	110,6	63	40	96	139	144,4	2	1
	3	1,1	144	122	76	40	99	166	173	2,5	1
	3	1,1	144	122	76	40	99	166	173	2,5	1
90	2	1	133,4	117,5	67	40	101	149	154,4	2	1
	2	1	133,4	117,5	67	40	101	149	154,4	2	1
	3	1,1	152,4	130,1	80	40	104	176	183	2,5	1
	3	1,1	152,4	130,1	80	40	104	176	183	2,5	1
95	2,1	1,1	141,5	125,3	72	40	107	158	163	2,1	1
	3	1,1	159,5	137,1	84	40	109	186	193	2,5	1
	3	1,1	159,5	137,1	84	40	109	186	193	2,5	1
100	2,1	1,1	149,6	132,3	76	40	112	168	173	2,1	1
	2,1	1,1	149,6	132,3	76	40	112	168	173	2,1	1
	3	1,1	171,7	146,3	90	40	114	201	208	2,5	1
	3	1,1	171,7	146,3	90	40	114	201	208	2,5	1
105	2,1	1,1	157,7	138,2	80	40	117	178	183	2,1	1
	3	1,1	178,9	154	94	40	119	211	218	2,5	1
110	2,1	1,1	165,7	144,9	84	40	122	188	193	2,1	1
	2,1	1,1	165,7	144,9	84	40	122	188	193	2,1	1
	3	1,1	190,9	162,3	98	40	124	226	233	2,5	1
	3	1,1	190,9	162,3	98	40	124	226	233	2,5	1
120	2,1	1,1	178,9	157,2	90	40	132	203	208	2,1	1
	3	1,1	207,1	176,4	107	40	134	246	253	2,5	1
130	3	1,1	191,8	169,6	96	40	144	216	223	2,5	1
	4	1,5	222,5	188,5	115	40	147	263	271	3	1,5
140	3	1,1	207,5	183,5	103	40	154	236	243	2,5	1
	4	1,5	239,5	204,4	123	40	157	283	291	3	1,5
150	3	1,1	223,5	197,5	111	40	164	256	263	2,5	1
	4	1,5	255,8	218,3	131	40	167	303	311	3	1,5
160	3	1,1	238	212	118	40	174	276	283	2,5	1
170	4	1,5	255,8	227,4	127	40	187	293	301	3	1,5
180	4	1,5	265,8	237,4	131	40	197	303	311	3	1,5

2 Double row angular contact ball bearings



Double row angular contact ball bearings are particularly suitable where:

- the design envelope is not sufficient under high loads for a pair of single row angular contact ball bearings
- high radial and axial loads are acting simultaneously
- tilting moments must also be supported
- a relatively rigid bearing arrangement is required
- the bearing arrangement is to run quietly in addition to meeting the requirements stated above.

For an overview of other product-specific features, see the Matrix for bearing preselection ► 280.



Double row angular contact ball bearing – comparison of design envelope with bearing set composed of single row angular contact ball bearings



B = total width of bearing or bearing set

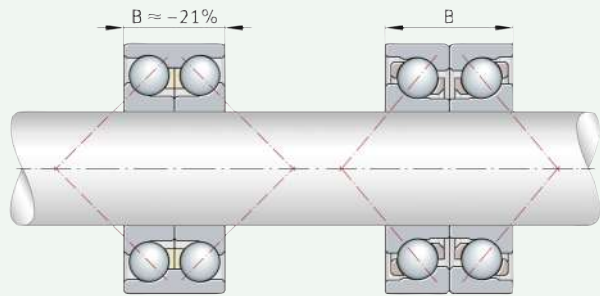

2.1 Bearing design

Design variants

Double row angular contact ball bearings are available as:

- bearings of basic design ► 315 | 2
- bearings with filling slot ► 315 | 3
- bearings with split inner ring ► 316 | 4
- X-life bearings ► 316.

Larger catalogue bearings and other bearing designs ► GL 1.

Bearings of basic design

Comparable with a pair of single row angular contact ball bearings

Double row bearings correspond in their structure to a pair of single row angular contact ball bearings in an O arrangement, but they are narrower to a certain extent. They differ in the size of the contact angle α and the design of the bearing rings. Due to the manufacturing processes used, open bearings, which are also available with sealing washers or sealing shields, can have turned recesses in the outer and/or inner ring for sealing washers or sealing shields.

Extensive and versatile range of product variants

Bearings of series 38..-B(-2RSR, -2Z), 30..-B(-2RSR, -2Z), 32..-B(-2RSR, -2Z), 32..-BD(-2HRS), 33..-B(-2RSR, -2Z), 33..BD(-2HRS) are self-retaining. They do not have filling slots in the end faces of the bearings rings ► 315 | 2. Bearings of series 32..-BD and 33..-BD have an optimised internal construction.

In design terms, double row angular contact ball bearings thus fulfil the requirements for:

- supporting axial loads in both directions and high radial loads
- low-noise running
- versatile application.

☞ **Nominal contact angle**
 $\alpha = 25^\circ$ or 30°

The nominal contact angle α in B designs is 25° , in the case of the BD variant, this is 30° .



2
 Double row angular contact ball bearing of basic design

F_r = radial load
 F_a = axial load
 α = nominal contact angle

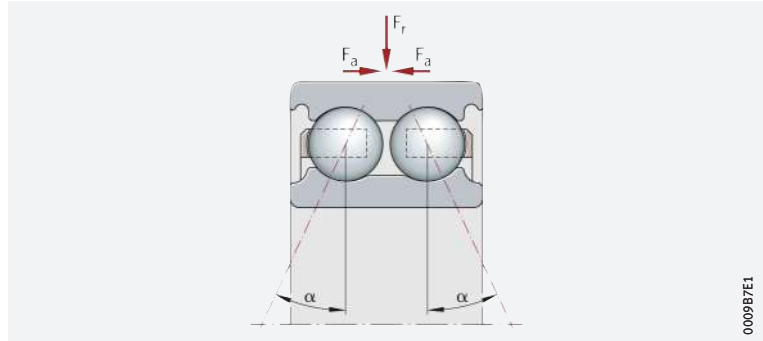

Bearings with filling slot

☞ **Nominal contact angle**
 $\alpha = 35^\circ$

Angular contact ball bearings of series 32 and 33 are self-retaining. They have filling slots on one end face of the bearing ring for filling the bearings with rolling elements ▶ 315 | 3. The nominal contact angle is $\alpha = 35^\circ$.



These series must be fitted such that the main load direction is supported by the row of balls without filling slots under axial load.



3
 Double row angular contact ball bearing with filling slot

F_r = radial load
 F_a = axial load
 α = nominal contact angle

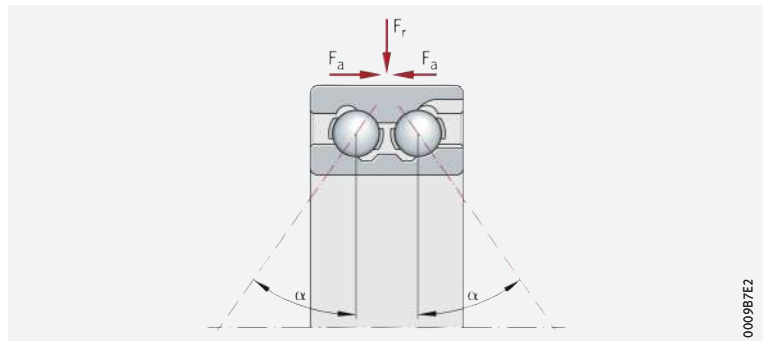

Bearings with split inner ring

☞ **Nominal contact angle**
 $\alpha = 45^\circ$

In angular contact ball bearings of series 33...-DA, the inner ring is split ▶ 316 | 4. The inner rings are not self-retaining. Filling the bearings with a large number of balls – in conjunction with the internal design of the bearing and the contact angle of 45° – allows high alternating axial loads to be supported.



The inner ring halves are matched to the particular bearing and must not be interchanged with those of other bearings of the same size.

4

Double row angular contact ball bearing with split inner ring

F_r = radial load

F_a = axial load

α = nominal contact angle

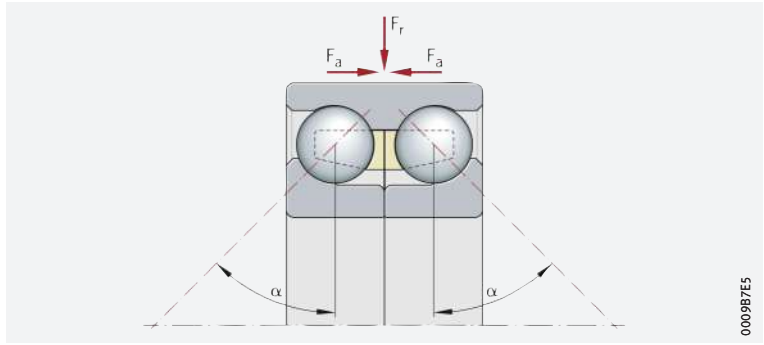

0009B7E5

X-life

X-life premium quality

Bearings of series 32...-BD and 33...-BD are X-life bearings > 330 | [grid]. These bearings exhibit considerably higher performance than standard double row angular contact ball bearings > 316 | [5]. This is achieved, for example, through the modified internal construction, higher surface quality of the contact surfaces and optimised cage design, as well as through the improved quality of the steel and rolling elements.

Advantages

Increased customer benefits due to X-life

- The technical enhancements offer a range of advantages, such as:
- a more favourable load distribution in the bearing and thus a higher dynamic load carrying capacity of the bearings > 316 | [5]
 - quieter running
 - running with reduced friction and greater energy efficiency
 - lower heat generation in the bearing
 - higher possible speeds
 - lower lubricant consumption and, consequently, longer maintenance intervals
 - a measurably longer operating life of the bearings
 - high operational security
 - compact, environmentally-friendly bearing arrangements.

Lower operating costs, higher machine availability

In conclusion, these advantages improve the overall cost-efficiency of the bearing position significantly and thus bring about a sustainable increase in the efficiency of the machine and equipment.

Suffix XL

X-life angular contact ball bearings include the suffix XL in the designation > 322 | [7], > 323 | [8] and > 330 | [grid].

5

Comparison of basic dynamic load rating C_r – bearing series 33...-BD-XL, bore code 02 to 16, with a bearing which is not of X-life quality (33...-B)

C_r = basic dynamic load rating

① Bore code

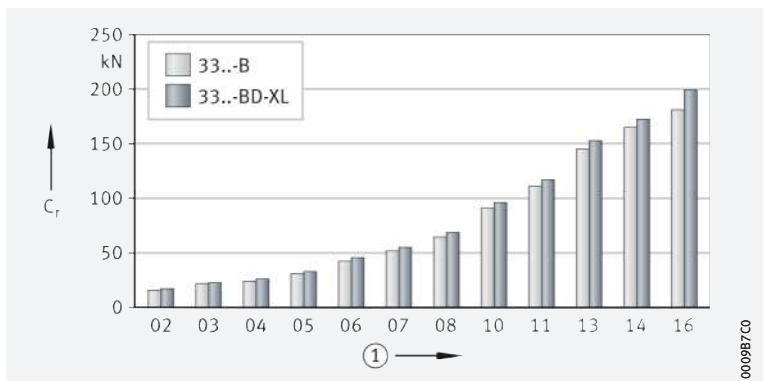

0009B7C0

Wide application range

Areas of application

Due to their special technical features, double row X-life angular contact ball bearings are highly suitable for bearing arrangements in:

- compressors
- fluid and hydraulic pumps
- automotive chassis and gearboxes
- industrial gearboxes
- agricultural vehicles
- elevators and packaging equipment
- heavy motorbikes
- machine tools
- textile machinery.



X-life indicates a high product performance density and thus a particularly significant benefit to the customer. Further information on X-life ► 10.



2.2 Load carrying capacity

Capable of supporting axial loads in both directions and radial loads

In addition to high radial loads, double row angular contact ball bearings can also support axial forces in both directions and tilting moments ► 315 | 2. They are highly suitable for bearing arrangements with rigid axial guidance.

Contact angle and axial load carrying capacity

The bearings are available with $\alpha = 25^\circ, 30^\circ, 35^\circ$ and 45° ► 315 | 2 to ► 316 | 4. The axial load carrying capacity increases with the size of the contact angle. In bearings without filling slots, it is the same in both directions.

2.3 Compensation of angular misalignments

The angular adjustment facility is very limited

The bearings are not suitable for the compensation of angular misalignments. In addition, misalignments induce internal forces, which not only lead to higher temperatures, but also to a reduction in the bearing rating life.

2.4 Lubrication

Angular contact ball bearings sealed on both sides are maintenance-free

Open bearings and bearings with seals on both sides are greased using a high quality grease. Bearings sealed on both sides are maintenance-free for many applications, i. e. they do not require relubrication.

Open bearings must be lubricated

Angular contact ball bearings without seals and with seals on one side of series 32.., 33.., 33..-DA, 32..-BD and 33..-BD are preserved and not greased. These bearings must be lubricated with oil or grease.

Compatibility with plastic cages

When using bearings with plastic cages, compatibility between the lubricant and the cage material must be ensured if synthetic oils, lubricating greases with a synthetic oil base or lubricants containing a high proportion of EP additives are used.

Observe oil change intervals

Aged oil and additives in the oil can impair the operating life of plastics at high temperatures. As a result, stipulated oil change intervals must be strictly observed.

2.5 Sealing

☞ *2RS, 2RSR and 2HRS seals are contact designs*

Series 38..-B, 30..-B, 32..-B and 33..-B with the suffix 2RS, 2RSR and 2HRS have lip seals in axial contact on both sides and in radial contact ▶ 322 | 5. Bearings with the suffix RS, HRS and RSR are sealed on one side with lip seals in axial and radial contact.

☞ *2Z sealing shields and 2RZ seals are non-contact designs*

Bearing series with the suffix 2Z have sheet steel sealing shields on both sides. Bearings with the suffix 2RZ are fitted with rubberised gap seals on both sides.

☞ *Open bearings*

In the case of unsealed bearings, sealing must be carried out by the adjacent construction. The sealing system should reliably prevent:

- moisture and contaminants from entering the bearing
- the egress of lubricant from the bearing.

2.6 Speeds

☞ *Limiting speeds and reference speeds in the product tables*

The product tables give two speeds for most bearings ▶ 330 | 5:

- the kinematic limiting speed n_G
- the thermal speed rating n_{gr} .

Limiting speeds



The limiting speed n_G is the kinematically permissible speed of the bearing. Even under favourable mounting and operating conditions, this value should not be exceeded without prior consultation with Schaeffler ▶ 64.

The values given in the product tables are valid for oil lubrication in the case of bearings without seals or shields and for grease lubrication where bearings are supplied greased and with seals or shields.

☞ *Values for grease lubrication*

For grease lubrication, 75% of the value stated in the product tables is permissible in each case.

Reference speeds

☞ *n_{gr} is used to calculate n_g*

The thermal speed rating n_{gr} is not an application-oriented speed limit, but is a calculated ancillary value for determining the thermally safe operating speed n_g ▶ 64.

☞ *Bearings with contact seals*

For bearings with contact seals, no reference speeds are defined in accordance with DIN ISO 15312:2004. As a result, only the limiting speed n_G is given in the product tables for these bearings.

2.7 Noise

The Schaeffler Noise Index (SGI) has been developed as a new feature for comparing the noise level of different bearing types and series. As a result, a noise evaluation of rolling bearings can now be carried out for the first time.

Schaeffler Noise Index

The SGI value is based on the maximum permissible noise level of a bearing in accordance with internal standards, which is calculated on the basis of ISO 15242. In order that different bearing types and series can be compared, the SGI value is plotted against the basic static load rating C_0 .

This permits direct comparisons between bearings with the same load carrying capacity. The upper limit value is given in each of the diagrams. This means that the average noise level of the bearings is lower than illustrated in the diagram.

! The Schaeffler Noise Index is an additional performance characteristic in the selection of bearings for noise-sensitive applications. The specific suitability of a bearing for an application in terms of installation space, load carrying capacity or speed limit for example, must be checked independently of this.

👁 The Noise Index is currently available for the main series. Additional series will be updated and introduced in subsequent publications.

Further information:

■ **medias** ➤ <https://medias.schaeffler.com>.



6
Schaeffler Noise Index
for double row angular contact
ball bearings

SGI = Schaeffler Noise Index
 C_0 = basic static load rating

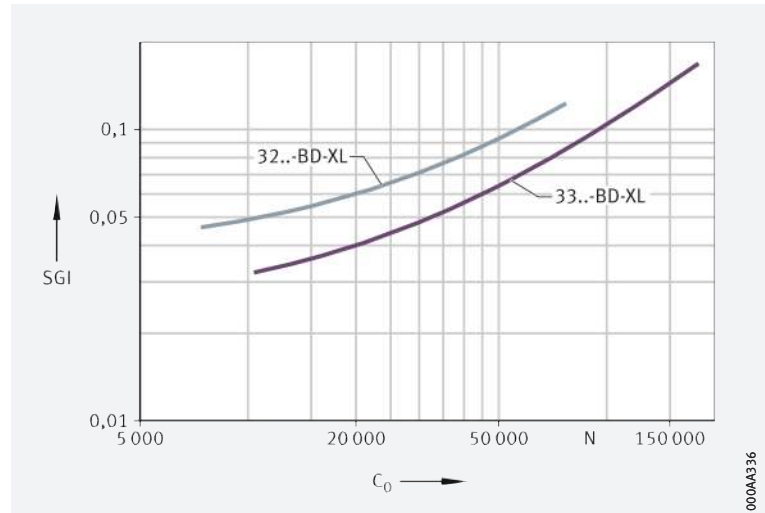

000AA336

2.8 Temperature range

👁 Limiting values

The operating temperature of the bearings is limited by:

- the dimensional stability of the bearing rings and rolling elements
- the cage
- the lubricant
- the seals.

Possible operating temperatures of double row angular contact ball bearings ➤ 319 | 1.

1
Permissible temperature ranges

Operating temperature	Double row angular contact ball bearings, open		Double row angular contact ball bearings, sealed
	with sheet steel or brass cage	with polyamide cage PA66	
	ungreased -30 °C to +150 °C	-30 °C to +120 °C, limited by the cage material	-30 °C to +110 °C, limited by the lubricant and seal material
	series 30, 38, 32..-BD and 33..-BD, D ≤ 90 mm, -30 °C to +120 °C		

@ In the event of anticipated temperatures which lie outside the stated values, please contact Schaeffler.

2.9 Cages

Solid cages made from brass and PA66, as well as sheet steel cages, are used as standard

Standard cages and additional cage designs for double row angular contact ball bearings are made from brass, polyamide or steel ➤ 320  2. Other cages are available by agreement. With such cages, however, suitability for high speeds and temperatures as well as the basic load ratings may differ from the values for the bearings with standard cages.



For high continuous temperatures and applications with difficult operating conditions, bearings with brass or sheet steel cages should be used. If there is any uncertainty regarding cage suitability, please consult Schaeffler.



Cage, cage suffix, bore code

Bearing series	Solid cage made from polyamide PA66		Solid brass cage		Sheet steel cage	
	TVH, TVP		M, MA		-	
	standard	also available for	standard	also available for	standard	also available for
Bore code						
32	-	-	19, 21, 22	18, 20	17, 18, 20	-
33	-	-	17, 19, 20, 22	18	14 to 16, 18	20
30..-B	up to 08	-	-	-	-	-
32..-B	00, 01, 14 to 18, 20	-	-	-	-	-
33..-B	01, 12	-	-	-	-	-
38..-B	00 to 12, 14, 16, 18, 20	-	-	-	-	-
32..-BD	-	02 to 13	-	-	02 to 13	-
33..-BD	-	02 to 11, 13, 14, 16	-	-	04 to 11, 13, 14	-
33..-DA	05	-	08, 10, 11, 15 to 22	05, 06, 07, 09, 12, 13, 14	06, 07, 09, 12, 13, 14	05

2.10 Internal clearance

Axial internal clearance – bearings with unsplit inner ring



Double row angular contact ball bearings with unsplit inner ring of the basic design have the axial internal clearance CN (group N) in accordance with DIN 628-3:2008 ➤ 321  3.



Bearings can also be supplied with an axial internal clearance which is larger or smaller than CN (C3, C4 or C2). In this case, please contact Schaeffler.

 **3**
Axial internal clearance
of double row angular contact
ball bearings with unsplit
inner ring

Nominal bore diameter d mm		Axial internal clearance							
		C2 (Group 2) μm		CN (Group N) μm		C3 (Group 3) μm		C4 (Group 4) μm	
over	incl.	min.	max.	min.	max.	min.	max.	min.	max.
–	10	1	11	5	21	12	28	25	45
10	18	1	12	6	23	13	31	27	47
18	24	2	14	7	25	16	34	27	47
24	30	2	15	8	27	18	37	30	50
30	40	2	16	9	29	21	40	33	54
40	50	2	18	11	33	23	44	36	58
50	65	3	22	13	36	26	48	40	63
65	80	3	24	15	40	30	54	46	71
80	100	3	26	18	46	35	63	55	83
100	120	4	30	22	53	42	73	65	96
120	140	4	34	25	59	48	82	74	108

 *Standard corresponds approximately to C3 for unsplit bearings*

Axial internal clearance – bearings with split inner ring

Bearings with a split inner ring are intended for higher axial loads. As a result, they generally also have a tighter fit than unsplit bearings. Their normal internal clearance corresponds approximately to the internal clearance group C3 for unsplit bearings ► 321 | .

 **4**
Axial internal clearance
of double row angular contact
ball bearings with split
inner ring

Nominal bore diameter d mm		Axial internal clearance					
		C2 (Group 2) μm		CN (Group N) μm		C3 (Group 3) μm	
over	incl.	min.	max.	min.	max.	min.	max.
24	30	8	27	16	35	27	46
30	40	9	29	18	38	30	50
40	50	11	33	22	44	36	58
50	65	13	36	25	48	40	63
65	80	15	40	29	54	46	71

2.11 Dimensions, tolerances

Dimension standards



The main dimensions of double row angular contact ball bearings correspond to DIN 628-3:2008. Nominal dimensions of double row angular contact ball bearings ► 330 | .



Chamfer dimensions



The limiting dimensions for chamfer dimensions correspond to DIN 620-6:2004. Overview and limiting values ► 135 | 7.11. Nominal value of chamfer dimension ► 330 | .

Tolerances



The tolerances for the dimensional and running accuracy of double row angular contact ball bearings correspond to tolerance class Normal in accordance with ISO 492:2014; the dimensional and running tolerances of bearings with the suffix BD correspond to the tolerance class 6 in accordance with ISO 492:2014. Tolerance values in accordance with ISO 492 ► 122 |  8 and ► 124 |  11.



2.12 Suffixes

For a description of the suffixes used in this chapter ▶ 322 | 5 and **medias** interchange ▶ <https://www.schaeffler.de/std/1D52>.

5
Suffixes and corresponding descriptions

Suffix	Description of suffix	
B	Modified internal construction, nominal contact angle $\alpha = 25^\circ$, without filling slot	Standard
BD	Modified internal construction, nominal contact angle $\alpha = 30^\circ$, without filling slot	
C2	Axial internal clearance C2 (smaller than normal)	Available by agreement
C3	Axial internal clearance C3 (larger than normal)	
C4	Axial internal clearance C4 (larger than C3)	
DA	Inner ring split, nominal contact angle $\alpha = 45^\circ$	Standard
M	Solid brass cage, ball-guided	Standard, dependent on bore code
MA	Solid brass cage, guided on outer ring	
TVH	Solid cage made from glass fibre reinforced polyamide PA66, ball-guided	
2HRS	Contact seal on both sides, axial contact (lip seal)	Standard
2RS	Contact seal on both sides, axial contact (lip seal)	
2RSR	Contact seal on both sides, radial contact (lip seal)	
2RZ	Non-contact seal on both sides (rubberised gap seal)	
2Z	Non-contact sealing shield on both sides (sheet metal gap seal)	
HRS	Contact seal on one side, axial contact (lip seal)	Special design, available by agreement
RS	Contact seal on one side, axial contact (lip seal)	
RSR	Contact seal on one side, radial contact (lip seal)	
RZ	Non-contact seal on one side (rubberised gap seal)	
Z	Non-contact sealing shield on one side (sheet metal gap seal)	
XL	X-life bearing, dependent on bore code and bearing type	

2.13 Structure of bearing designation

Examples of composition of bearing designation

The designation of bearings follows a set model. Examples ▶ 322 | 7 and ▶ 323 | 8. The composition of designations is subject to DIN 623-1 ▶ 102 | 10.

7
Double row angular contact ball bearing of basic design: designation structure

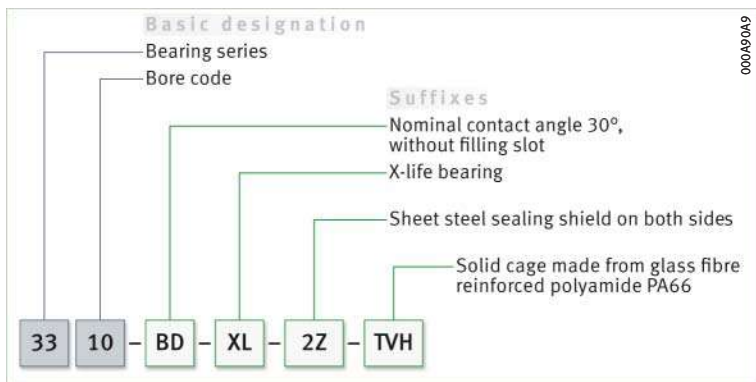

8
Double row angular contact ball bearing with split inner ring: design structure



2.14 Dimensioning

Valid for
 $\alpha = 25^\circ, 30^\circ, 35^\circ, 45^\circ$

Equivalent dynamic bearing load

The calculation of P is dependent on the nominal contact angle α of the bearing, the load ratio F_a/F_r and the calculation factors from [▶ 323 | f1](#) to [▶ 323 | f8](#).



The further fundamental information on the calculation of the equivalent dynamic bearing load must be observed [▶ 294 | 1.14](#).

f1

Equivalent dynamic load
 $\alpha = 25^\circ$

$$\frac{F_a}{F_r} \leq 0,68 \Rightarrow P = F_r + 0,92 \cdot F_a$$

f2

Equivalent dynamic load
 $\alpha = 25^\circ$

$$\frac{F_a}{F_r} > 0,68 \Rightarrow P = 0,67 \cdot F_r + 1,41 \cdot F_a$$

f3

Equivalent dynamic load
 $\alpha = 30^\circ$

$$\frac{F_a}{F_r} \leq 0,8 \Rightarrow P = F_r + 0,78 \cdot F_a$$

f4

Equivalent dynamic load
 $\alpha = 30^\circ$

$$\frac{F_a}{F_r} > 0,8 \Rightarrow P = 0,63 \cdot F_r + 1,24 \cdot F_a$$

f5

Equivalent dynamic load
 $\alpha = 35^\circ$

$$\frac{F_a}{F_r} \leq 0,95 \Rightarrow P = F_r + 0,66 \cdot F_a$$

f6

Equivalent dynamic load
 $\alpha = 35^\circ$

$$\frac{F_a}{F_r} > 0,95 \Rightarrow P = 0,6 \cdot F_r + 1,07 \cdot F_a$$

f7

Equivalent dynamic load
 $\alpha = 45^\circ$

$$\frac{F_a}{F_r} \leq 1,34 \Rightarrow P = F_r + 0,47 \cdot F_a$$

f8

Equivalent dynamic load
 $\alpha = 45^\circ$

$$\frac{F_a}{F_r} > 1,34 \Rightarrow P = 0,54 \cdot F_r + 0,81 \cdot F_a$$

Legend

P	N	Equivalent dynamic bearing load
F_r	N	Radial load
F_a	N	Axial load.

Equivalent static bearing load

 Valid for $\alpha = 25^\circ, 30^\circ, 35^\circ, 45^\circ$

The calculation of the equivalent static bearing load P_0 is dependent on the nominal contact angle α and the calculation factors [▶ 324 | f1 9](#) to [▶ 324 | f1 12](#).

 **f1 9**
Equivalent static load
 $\alpha = 25^\circ$

$$P_0 = F_{0r} + 0,76 \cdot F_{0a}$$

 **f1 10**
Equivalent static load
 $\alpha = 30^\circ$

$$P_0 = F_{0r} + 0,66 \cdot F_{0a}$$

 **f1 11**
Equivalent static load
 $\alpha = 35^\circ$

$$P_0 = F_{0r} + 0,58 \cdot F_{0a}$$

 **f1 12**
Equivalent static load
 $\alpha = 45^\circ$

$$P_0 = F_{0r} + 0,44 \cdot F_{0a}$$

Legend

P_0	N	Equivalent static bearing load
F_{0r}, F_{0a}	N	Largest radial or axial load present (maximum load).

Static load safety factor

 $S_0 = C_0/P_0$

In addition to the basic rating life $L (L_{10h})$, it is also always necessary to check the static load safety factor S_0 [▶ 324 | f1 13](#).

 **f1 13**
Static load safety factor

$$S_0 = \frac{C_0}{P_0}$$

Legend

S_0	-	Static load safety factor
C_0	N	Basic static load rating
P_0	N	Equivalent static bearing load.

2.15 Minimum load

 In order to prevent damage due to slippage, a minimum radial load of $P > C_{0r}/100$ is required



In order that no slippage occurs between the contact partners, the double row angular contact ball bearings must be constantly subjected to a sufficiently high load. Based on experience, a minimum radial load of the order of $P > C_{0r}/100$ is thus necessary. In most cases, however, the radial load is already higher than the requisite minimum load due to the weight of the supported parts and the external forces.



If the minimum radial load is lower than indicated above, please consult Schaeffler.

2.16 Design of bearing arrangements

☞ *Support bearing rings over their entire circumference and width*

In order to allow full utilisation of the load carrying capacity of the bearings and thus also achieve the requisite rating life, the bearing rings must be rigidly and uniformly supported by means of contact surfaces over their entire circumference and over the entire width of the raceway. Support can be provided by means of a cylindrical seating surface. The seating and contact surfaces should not be interrupted by grooves, holes or other recesses. The accuracy of mating parts must meet specific requirements ▶ 326 |  6 to ▶ 326 |  8.





☞ *For secure radial location, tight fits are necessary*

Radial location of bearings – fit recommendations



In addition to supporting the rings adequately, the bearings must also be securely located in a radial direction, to prevent creep of the bearing rings on the mating parts under load. This is generally achieved by means of tight fits between the bearing rings and the mating parts. If the rings are not secured adequately or correctly, this can cause severe damage to the bearings and adjacent machine parts. Influencing factors, such as the conditions of rotation, magnitude of the load, internal clearance, temperature conditions, design of the mating parts and the mounting and dismantling options must be taken into consideration in the selection of fits.



If shock type loads occur, tight fits (transition fit or interference fit) are required to prevent the rings from coming loose at any point. Clearance, transition or interference fits ▶ 150 |  6 and ▶ 158 |  7.



The following information provided in Technical principles must be taken into consideration in the design of bearing arrangements:

- conditions of rotation ▶ 145
- tolerance classes for cylindrical shaft seats (radial bearings) ▶ 147 |  2
- shaft fits ▶ 150
- tolerance classes for bearing seats in housings (radial bearings) ▶ 148 |  4
- housing fits ▶ 158



☞ *The bearings must also be securely located in an axial direction*

Axial location of bearings – location methods

As a tight fit alone is not normally sufficient to also locate the bearing rings securely on the shaft and in the housing bore in an axial direction, this must usually be achieved by means of an additional axial location or retention method. The axial location of the bearing rings must be matched to the type of bearing arrangement. Shaft and housing shoulders, housing covers, nuts, spacer rings and retaining rings etc., are fundamentally suitable.

☞ *For bearings with tolerance class Normal, a minimum of IT6 should be provided for the shaft seat and a minimum of IT7 for the housing seat*

Dimensional, geometrical and running accuracy of the bearing seats

The accuracy of the bearing seat on the shaft and in the housing should correspond to the accuracy of the bearing used. For double row angular contact ball bearings with the tolerance class Normal, the shaft seat should correspond to a minimum of standard tolerance grade IT6 and the housing seat to a minimum of IT7; with tolerance class 6, the shaft seat should correspond to a minimum of IT5 and the housing seat to a minimum of IT6. Guide values for the geometrical and positional tolerances of bearing seating surfaces ▶ 326 |  6, tolerances t_1 to t_3 in accordance with ▶ 168 |  11. Numerical values for IT grades ▶ 326 |  7.

6
Guide values
for the geometrical and
positional tolerances
of bearing seating surfaces

Bearing tolerance class		Bearing seating surface	Standard tolerance grades to ISO 286-1 (IT grades)			
to ISO 492	to DIN 620		Diameter tolerance	Roundness tolerance	Parallelism tolerance	Total axial runout tolerance of abutment shoulder
				t ₁	t ₂	t ₃
Normal	PN (P0)	Shaft	IT6 (IT5)	Circumferential load IT4/2	Circumferential load IT4/2	IT4
				Point load IT5/2	Point load IT5/2	
		Housing	IT7 (IT6)	Circumferential load IT5/2	Circumferential load IT5/2	IT5
				Point load IT6/2	Point load IT6/2	
6	P6	Shaft	IT5	Circumferential load IT3/2	Circumferential load IT3/2	IT3
				Point load IT4/2	Point load IT4/2	
		Housing	IT6	Circumferential load IT4/2	Circumferential load IT4/2	IT4
				Point load IT5/2	Point load IT5/2	

7
Numerical values
for ISO standard tolerances
(IT grades) to ISO 286-1:2010

IT grade	Nominal dimension in mm							
	over 3	6	10	18	30	50	80	120
	incl. 6	10	18	30	50	80	120	180
Values in µm								
IT3	2,5	2,5	3	4	4	5	6	8
IT4	4	4	5	6	7	8	10	12
IT5	5	6	8	9	11	13	15	18
IT6	8	9	11	13	16	19	22	25
IT7	12	15	18	21	25	30	35	40

Roughness of cylindrical bearing seats

Ra must not be too high

The roughness of the bearing seats must be matched to the tolerance class of the bearings. The mean roughness value Ra must not be too high, in order to maintain the interference loss within limits. The shafts must be ground, while the bores must be precision turned. Guide values as a function of the IT grade of bearing seating surfaces ► 326 | **8**.

8
Roughness values
for cylindrical bearing seating
surfaces – guide values

Nominal diameter of the bearing seat d (D)		Recommended mean roughness value for ground bearing seats Ramax			
mm		µm			
		Diameter tolerance (IT grade)			
over	incl.	IT7	IT6	IT5	IT4
–	80	1,6	0,8	0,4	0,2
80	500	1,6	1,6	0,8	0,4

The contact surfaces for the rings must be of sufficient height

Mounting dimensions for the contact surfaces of bearing rings

The mounting dimensions of the shaft and housing shoulders, and spacer rings etc., must ensure that the contact surfaces for the bearing rings are of sufficient height. However, they must also reliably prevent rotating parts of the bearing from grazing stationary parts. Proven mounting dimensions for the radii and diameters of abutment shoulders ▶ 330 . These dimensions are limiting dimensions (maximum or minimum dimensions); the actual values should not be higher or lower than specified.



2.17 Mounting and dismounting



The mounting and dismounting options for angular contact ball bearings, by thermal, hydraulic or mechanical methods, must be taken into consideration in the design of the bearing position.

Ensure that the bearings are not damaged during mounting

In the mounting of non-separable (self-retaining) angular contact ball bearings, the mounting forces must always be applied to the bearing ring with a tight fit.

Simplified mounting of bearings due to split inner ring

Bearings with split inner ring

These angular contact ball bearings are not self-retaining. As a result, the outer ring with the ball and cage assembly can be mounted separately from the two inner ring halves. This gives simplified mounting of the bearings.

Rolling bearings must be handled with great care

Schaeffler Mounting Handbook

Rolling bearings are well-proven precision machine elements for the design of economical and reliable bearing arrangements, which offer high operational security. In order that these products can function correctly and achieve the envisaged operating life without detrimental effect, they must be handled with care.



The Schaeffler Mounting Handbook MH 1 gives comprehensive information about the correct storage, mounting, dismounting and maintenance of rotary rolling bearings ▶ <https://www.schaeffler.de/std/1D53>. It also provides information which should be observed by the designer, in relation to the mounting, dismounting and maintenance of bearings, in the original design of the bearing position. This book is available from Schaeffler on request.

2.18 Legal notice regarding data freshness

The further development of products may also result in technical changes to catalogue products

Of central interest to Schaeffler is the further development and optimisation of its products and the satisfaction of its customers. In order that you, as the customer, can keep yourself optimally informed about the progress that is being made here and with regard to the current technical status of the products, we publish any product changes which differ from the printed version in our electronic product catalogue.



We therefore reserve the right to make changes to the data and illustrations in this catalogue. This catalogue reflects the status at the time of printing. More recent publications released by us (as printed or digital media) will automatically precede this catalogue if they involve the same subject. Therefore, please always use our electronic product catalogue to check whether more up-to-date information or modification notices exist for your desired product.

Link to electronic product catalogue



The following link will take you to the Schaeffler electronic product catalogue: ▶ <https://medias.schaeffler.com>.

2.19 Further information

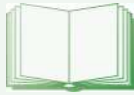

In addition to the data in this chapter, the following chapters in Technical principles must also be observed in the design of bearing arrangements:

- Determining the bearing size ▶ 34
- Rigidity ▶ 54
- Friction and increases in temperature ▶ 56
- Speeds ▶ 64
- Bearing data ▶ 97
- Lubrication ▶ 70
- Sealing ▶ 182
- Design of bearing arrangements ▶ 139
- Mounting and dismounting ▶ 191.



Angular contact ball bearings

Double row

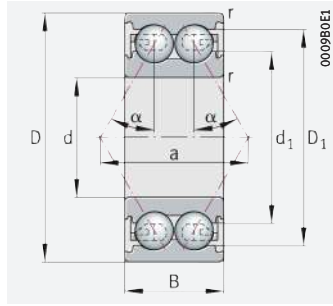

38..-B, 30..-B, 32..-B, 33..-B,
32..-BD, 33..-BD, 32, 33

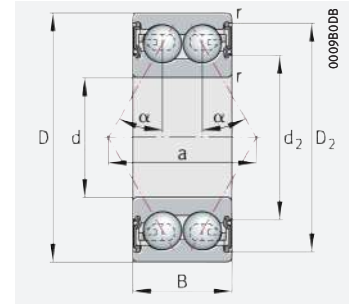

38..-B, 30..-B, 32..-B, 33..-B,
32..-BD, 33..-BD;
with seal 2HRS, 2RS, 2RSR, 2RZ, 2Z

d = 5 – 12 mm

Main dimensions			Basic load ratings		Fatigue limit load C_{ur} N	Limiting speed n_G min^{-1}	Speed rating $n_{\theta r}$ min^{-1}	Mass m \approx kg	Designation
d	D	B	dyn. C_r N	stat. C_{0r} N					
5	14	7	1780	940	47,5	51 000	31 500	0,005	30/5-B-TVH
	14	7	1780	940	47,5	38 000	31 500	0,006	30/5-B-2Z-TVH
	14	7	1780	940	47,5	30 500	–	0,006	30/5-B-2RSR-TVH
6	17	9	3050	1400	72	42 000	32 000	0,011	30/6-B-TVH
	17	9	3050	1400	72	31 500	32 000	0,011	30/6-B-2Z-TVH
	17	9	3050	1400	72	28 000	–	0,011	30/6-B-2RSR-TVH
7	19	10	3650	1690	86	39 500	31 500	0,01	30/7-B-TVH
	19	10	3650	1690	86	29 500	31 500	0,01	30/7-B-2Z-TVH
	19	10	3650	1690	86	25 500	–	0,01	30/7-B-2RSR-TVH
8	22	11	5100	2600	132	34 500	26 000	0,018	30/8-B-TVH
	22	11	5100	2600	132	26 000	26 000	0,018	30/8-B-2Z-TVH
	22	11	5100	2600	132	25 500	–	0,018	30/8-B-2RSR-TVH
10	19	7	2080	1370	70	40 500	21 000	0,008	3800-B-TVH
	19	7	2080	1370	70	30 500	21 000	0,008	3800-B-2RZ-TVH
	19	7	2080	1370	70	21 100	–	0,008	3800-B-2RS-TVH
	26	12	5700	3200	192	31 000	21 900	0,022	3000-B-TVH
	26	12	5700	3200	161	23 400	21 900	0,022	3000-B-2RZ-TVH
	26	12	5700	3200	161	18 100	–	0,022	3000-B-2RS-TVH
	30	14	7800	4450	226	21 100	21 000	0,052	3200-B-TVH
	30	14	7800	4450	226	21 100	21 000	0,05	3200-B-2Z-TVH
12	30	14	7800	4450	226	16 100	–	0,053	3200-B-2RS-TVH
	21	7	2150	1520	77	37 500	18 100	0,009	3801-B-TVH
	21	7	2150	1520	77	28 000	18 100	0,01	3801-B-2RZ-TVH
	21	7	2150	1520	77	17 500	–	0,01	3801-B-2RS-TVH
	28	12	6100	3700	188	29 500	19 300	0,025	3001-B-TVH
	28	12	6100	3700	188	22 000	19 300	0,032	3001-B-2RZ-TVH
	28	12	6100	3700	188	15 800	–	0,032	3001-B-2RS-TVH
	32	15,9	10 500	5800	295	18 400	20 000	0,051	3201-B-TVH
	32	15,9	10 500	5800	295	18 400	20 000	0,06	3201-B-2Z-TVH
	32	15,9	10 500	5800	295	15 000	–	0,057	3201-B-2RS-TVH
	37	19	14 600	8300	420	20 400	13 000	0,093	3301-B-TVH
37	19	14 600	8300	420	15 300	13 000	0,093	3301-B-2Z-TVH	
37	19	14 600	8300	420	14 100	–	0,093	3301-B-2RS-TVH	

medias ► <https://www.schaeffler.de/std/1D8D>

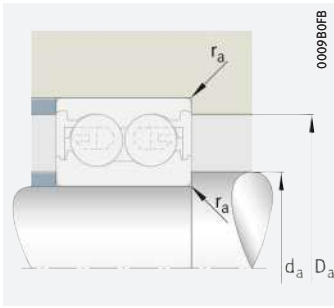

Mounting dimensions



Dimensions							Nominal contact angle α	Mounting dimensions		
d	r	D ₁	D ₂	d ₁	d ₂	a		d _a	D _a	r _a
	min.	≈	≈	≈	≈	≈	°	min.	max.	max.
5	0,2	11,2	–	8,8	–	6,9	25	6,4	12,6	0,2
	0,2	–	12,7	–	8,5	6,9	25	6,4	12,6	0,2
	0,2	–	12,7	–	8,5	6,9	25	6,4	12,6	0,2
6	0,3	13,4	–	9,6	–	8,8	25	8	15	0,3
	0,3	–	14,8	–	8,3	8,8	25	8	15	0,3
	0,3	–	14,8	–	8,3	8,8	25	8	15	0,3
7	0,3	14,6	–	10,4	–	9,6	25	9	17	0,3
	0,3	–	16,5	–	9	9,6	25	9	17	0,3
	0,3	–	16,5	–	9	9,6	25	9	17	0,3
8	0,3	17,6	–	12,6	–	11,2	25	10	20	0,3
	0,3	–	19	–	10,5	11,2	25	10	20	0,3
	0,3	–	19	–	10,5	11,2	25	10	20	0,3
10	0,3	15,9	–	13,3	–	9	25	12	17	0,3
	0,3	–	16,7	–	12,2	9	25	12	17	0,3
	0,3	–	16,7	–	12,2	9	25	12	17	0,3
	0,3	20,6	–	15,8	–	12,6	25	12	24	0,3
	0,3	–	21,2	–	14,2	12,6	25	12	24	0,3
	0,3	–	21,2	–	14,2	12,3	25	12	24	0,3
	0,6	23	–	16,6	–	14,79	25	14,2	25,8	0,6
	0,6	–	24,9	–	15,5	14,79	25	14,2	25,8	0,6
	0,6	–	24,9	–	15,5	14,79	25	14,2	25,8	0,6
12	0,3	18	–	15,3	–	9,9	25	14	19	0,3
	0,3	–	18,9	–	14,2	9,9	25	14	19	0,3
	0,3	–	18,9	–	14,2	9,9	25	14	19	0,3
	0,3	22,5	–	17,6	–	13,5	25	14	26	0,3
	0,3	–	23,2	–	16,4	13,5	25	14	26	0,3
	0,3	–	23,2	–	16,4	13,5	25	14	26	0,3
	0,6	26	–	17,8	–	16,53	25	16,2	27,8	0,6
	0,6	–	27,8	–	17,1	16,53	25	16,2	27,8	0,6
	0,6	–	27,8	–	17,1	16,53	25	16,2	27,8	0,6
	1	30,5	–	21,7	–	19,8	25	17,6	31,4	1
	1	–	32,1	–	18,7	19,8	25	17,6	31,4	1
1	–	32,1	–	18,7	19,8	25	17,6	31,4	1	



Angular contact ball bearings

Double row

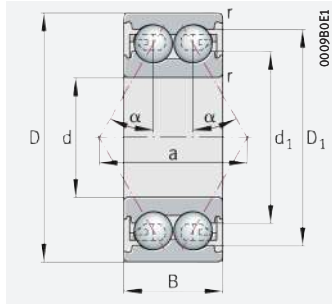

38..-B, 30..-B, 32..-B, 33..-B,
32..-BD, 33..-BD, 32, 33

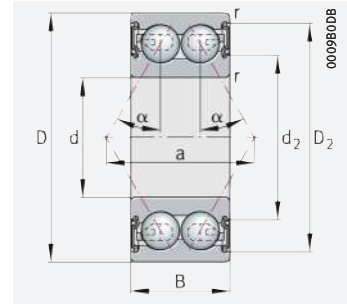

38..-B, 30..-B, 32..-B, 33..-B,
32..-BD, 33..-BD;
with seal 2HRS, 2RS, 2RSR, 2RZ, 2Z

d = 15 – 17 mm

Main dimensions			Basic load ratings		Fatigue limit load C_{ur}	Limiting speed n_G	Speed rating n_{dr}	Mass m	Designation
d	D	B	dyn. C_r	stat. C_{0r}					
			N	N	N	min ⁻¹	min ⁻¹	≈ kg	
15	24	7	2 080	1 560	79	33 500	14 900	0,01	3802-B-TVH
	24	7	2 080	1 560	79	25 000	14 900	0,012	3802-B-2RZ-TVH
	24	7	2 080	1 560	79	14 600	–	0,012	3802-B-2RS-TVH
	32	13	8 500	5 400	280	23 900	15 700	0,042	3002-B-TVH
	32	13	8 500	5 400	280	17 900	15 700	0,05	3002-B-2RZ-TVH
	32	13	8 500	5 400	280	13 000	–	0,05	3002-B-2RS-TVH
	35	15,9	12 600	7 400	500	22 300	18 500	0,066	3202-BD-XL-TVH
	35	15,9	12 600	7 400	500	16 700	18 500	0,065	3202-BD-XL-2Z-TVH
	35	15,9	12 600	7 400	500	16 700	–	0,065	3202-BD-XL-2HRS-TVH
	42	19	17 000	10 400	700	18 400	12 100	0,124	3302-BD-XL-TVH
42	19	17 000	10 400	700	13 800	12 100	0,122	3302-BD-XL-2Z-TVH	
42	19	17 000	10 400	700	13 800	–	0,122	3302-BD-XL-2HRS-TVH	
17	26	7	2 430	2 020	105	30 500	13 200	0,011	3803-B-TVH
	26	7	2 430	2 020	105	23 000	13 200	0,013	3803-B-2RZ-TVH
	26	7	2 430	2 020	105	13 200	–	0,013	3803-B-2RS-TVH
	35	14	9 100	6 100	305	22 500	15 300	0,042	3003-B-TVH
	35	14	9 100	6 100	305	16 800	15 300	0,057	3003-B-2RZ-TVH
	35	14	9 100	6 100	305	12 300	–	0,055	3003-B-2RS-TVH
	40	17,5	15 500	9 500	640	19 400	16 600	0,095	3203-BD-XL-TVH
	40	17,5	15 500	9 500	640	14 600	16 600	0,094	3203-BD-XL-2Z-TVH
	40	17,5	15 500	9 500	640	14 600	–	0,093	3203-BD-XL-2HRS-TVH
	47	22,2	22 500	13 100	880	16 600	12 600	0,177	3303-BD-XL-TVH
47	22,2	22 500	13 100	880	12 400	12 600	0,176	3303-BD-XL-2Z-TVH	
47	22,2	22 500	13 100	880	12 400	–	0,176	3303-BD-XL-2HRS-TVH	

medias ► <https://www.schaeffler.de/std/1D8E>

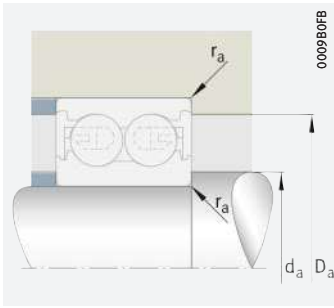

Mounting dimensions



Dimensions							Nominal contact angle α	Mounting dimensions		
d	r	D ₁	D ₂	d ₁	d ₂	a		d _a	D _a	r _a
	min.	≈	≈	≈	≈	≈	°	min.	max.	max.
15	0,3	20,9	–	18,3	–	11,3	25	17	22	0,3
	0,3	–	21,8	–	17,2	11,3	25	17	22	0,3
	0,3	–	21,8	–	17,2	11,3	25	17	22	0,3
	0,3	27,2	–	21,3	–	18,4	25	17	30	0,3
	0,3	–	27,9	–	19,7	18,4	25	17	30	0,3
	0,3	–	27,9	–	19,7	18,4	25	17	30	0,3
	0,6	29,4	–	22,2	–	20,7	30	19,2	30,8	0,6
	0,6	–	31,1	–	21	20,7	30	19,2	30,8	0,6
	0,6	–	31,1	–	21	20,7	30	19,2	30,8	0,6
	1	35,7	–	27,2	–	24,8	30	20,6	36,4	1
	1	–	37,9	–	25,8	24,8	30	20,6	36,4	1
	1	–	37,9	–	25,8	24,8	30	20,6	36,4	1
17	0,3	22,9	–	20,3	–	12,3	25	19	24	0,3
	0,3	–	23,8	–	19,2	12,3	25	19	24	0,3
	0,3	–	23,8	–	19,2	12,3	25	19	24	0,3
	0,3	29,1	–	23,1	–	17,1	25	19	33	0,3
	0,3	–	29,8	–	21	17,1	25	19	33	0,3
	0,3	–	29,8	–	21	17,1	25	19	33	0,3
	0,6	33,9	–	25,8	–	23,5	30	21,2	35,8	0,6
	0,6	–	36,1	–	24,4	23,5	30	21,2	35,8	0,6
	0,6	–	36,1	–	24,4	23,5	30	21,2	35,8	0,6
	1	39	–	28,5	–	27,5	30	22,6	41,4	1
	1	–	41,1	–	27,1	27,5	30	22,6	41,4	1
	1	–	41,1	–	27,1	27,5	30	22,6	41,4	1



Angular contact ball bearings

Double row

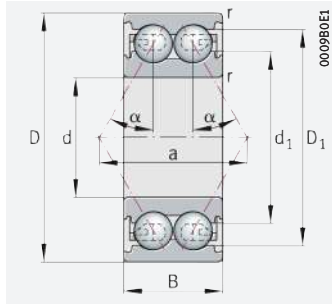

38...-B, 30...-B, 32...-B, 33...-B,
32...-BD, 33...-BD, 32, 33

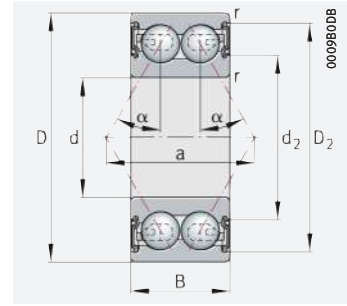

38...-B, 30...-B, 32...-B, 33...-B,
32...-BD, 33...-BD;
with seal 2HRS, 2RS, 2RSR, 2RZ, 2Z

d = 20 – 25 mm

Main dimensions			Basic load ratings		Fatigue limit load C_{ur}	Limiting speed n_G	Speed rating $n_{\theta r}$	Mass m	Designation
d	D	B	dyn. C_r	stat. C_{0r}					
			N	N	N	min^{-1}	min^{-1}	≈ kg	
20	32	10	5 600	4 750	240	23 200	11 800	0,024	3804-B-TVH
	32	10	5 600	4 750	240	17 400	11 800	0,026	3804-B-2RZ-TVH
	32	10	5 600	4 750	240	10 700	–	0,026	3804-B-2RS-TVH
	42	16	14 300	9 400	475	18 100	13 200	0,08	3004-B-TVH
	42	16	14 300	9 400	475	13 600	13 200	0,094	3004-B-2RZ-TVH
	42	16	14 300	9 400	475	10 500	–	0,094	3004-B-2RS-TVH
	47	20,6	20 600	12 900	870	16 100	14 700	0,154	3204-BD-XL-TVH
	47	20,6	20 600	12 900	870	12 100	14 700	0,153	3204-BD-XL-2Z-TVH
	47	20,6	20 600	12 900	870	12 100	–	0,149	3204-BD-XL-2HRS-TVH
	52	22,2	24 600	15 900	1 070	14 700	10 400	0,215	3304-BD-XL-TVH
52	22,2	24 600	15 900	1 070	11 000	10 400	0,214	3304-BD-XL-2Z-TVH	
52	22,2	24 600	15 900	1 070	11 000	–	0,217	3304-BD-XL-2HRS-TVH	
25	37	10	5 900	5 500	275	20 400	10 300	0,034	3805-B-TVH
	37	10	5 900	5 500	275	15 300	10 300	0,036	3805-B-2RZ-TVH
	37	10	5 900	5 500	275	9 300	–	0,036	3805-B-2RS-TVH
	47	16	15 200	10 900	550	15 900	11 100	0,1	3005-B-TVH
	47	16	15 200	10 900	550	11 900	11 100	0,1	3005-B-2RZ-TVH
	47	16	15 200	10 900	550	8 800	–	0,1	3005-B-2RS-TVH
	52	20,6	22 000	15 200	1 020	14 300	12 500	0,174	3205-BD-XL-TVH
	52	20,6	22 000	15 200	1 020	10 700	12 500	0,175	3205-BD-XL-2Z-TVH
	52	20,6	22 000	15 200	1 020	10 700	–	0,176	3205-BD-XL-2HRS-TVH
	62	25,4	30 000	23 200	1 400	13 100	8 400	0,341	3305-DA-TVP
	62	25,4	31 500	21 000	1 410	12 400	9 400	0,352	3305-BD-XL-TVH
	62	25,4	31 500	21 000	1 410	9 300	9 400	0,348	3305-BD-XL-2Z-TVH
62	25,4	31 500	21 000	1 410	9 300	–	0,352	3305-BD-XL-2HRS-TVH	

medias ► <https://www.schaeffler.de/std/1D8F>

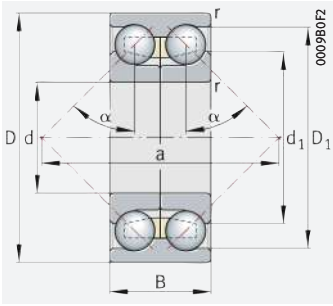

33...-DA;
split inner ring

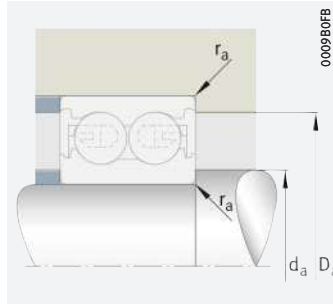

Mounting dimensions



Dimensions							Nominal contact angle α	Mounting dimensions		
d	r	D ₁	D ₂	d ₁	d ₂	a		d _a	D _a	r _a
	min.	≈	≈	≈	≈	≈	°	min.	max.	max.
20	0,3	29,2	–	25,1	–	16,1	25	22	30	0,3
	0,3	–	30,1	–	23,9	16,1	25	22	30	0,3
	0,3	–	30,1	–	23,9	16,1	25	22	30	0,3
	0,6	35	–	27,1	–	21,1	25	23,2	38,8	0,6
	0,6	–	36,4	–	25,3	21,1	25	23,2	38,8	0,6
	0,6	–	36,4	–	25,3	21,1	25	23,2	38,8	0,6
	1	40,1	–	30,8	–	27,9	30	25,6	41,4	1
	1	–	42,2	–	29,2	27,9	30	25,6	41,4	1
	1	–	42,2	–	29,2	27,9	30	25,6	41,4	1
	1,1	44	–	33,5	–	30,4	30	27	45	1
	1,1	–	46,1	–	31,9	30,4	30	27	45	1
25	0,3	33,2	–	29,1	–	17,9	25	27	35	0,3
	0,3	–	34,1	–	27,9	17,9	25	27	35	0,3
	0,3	–	34,1	–	27,9	17,9	25	27	35	0,3
	0,6	40,1	–	32,1	–	23,4	25	28,2	43,8	0,6
	0,6	–	41,8	–	30,3	23,4	25	28,2	43,8	0,6
	0,6	–	41,8	–	30,3	23,4	25	28,2	43,8	0,6
	1	45,1	–	35,8	–	30,8	30	30,6	46,4	1
	1	–	47,6	–	34,2	30,8	30	30,6	46,4	1
	1	–	47,6	–	34,2	30,8	30	30,6	46,4	1
	1,1	51,8	–	41	–	56	45	32	55	1
	1,1	51,5	–	39,5	–	35,4	30	32	55	1
1,1	–	53,7	–	37,6	35,4	30	32	55	1	
1,1	–	53,7	–	37,6	35,4	30	32	55	1	



Angular contact ball bearings

Double row

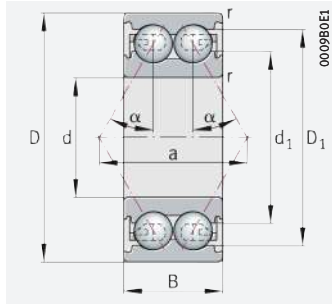

38..-B, 30..-B, 32..-B, 33..-B,
32..-BD, 33..-BD, 32, 33

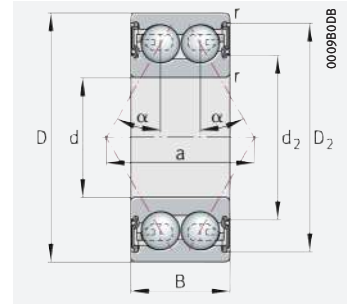

38..-B, 30..-B, 32..-B, 33..-B,
32..-BD, 33..-BD;
with seal 2HRS, 2RS, 2RSR, 2RZ, 2Z

d = 30 – 35 mm

Main dimensions			Basic load ratings		Fatigue limit load	Limiting speed	Speed rating	Mass	Designation
d	D	B	dyn. C_r	stat. C_{0r}	C_{ur}	n_G	$n_{\theta r}$	m	
			N	N	N	min ⁻¹	min ⁻¹	≈ kg	
30	42	10	6 100	6 000	315	17 700	8 700	0,035	3806-B-TVH
	42	10	6 100	6 000	315	13 300	8 700	0,037	3806-B-2RZ-TVH
	42	10	6 100	6 000	315	8 100	–	0,037	3806-B-2RS-TVH
	55	19	19 900	15 400	780	13 500	10 100	0,16	3006-B-TVH
	55	19	19 900	15 400	780	10 100	10 100	0,16	3006-B-2RZ-TVH
	55	19	19 900	15 400	780	7 400	–	0,16	3006-B-2RS-TVH
	62	23,8	31 000	22 200	1 490	11 900	11 100	0,288	3206-BD-XL-TVH
	62	23,8	31 000	22 200	1 490	9 000	11 100	0,283	3206-BD-XL-2Z-TVH
	62	23,8	31 000	22 200	1 490	9 000	–	0,29	3206-BD-XL-2HRS-TVH
	72	30,2	41 500	34 500	1 820	10 900	7 500	0,657	3306-DA
	72	30,2	43 000	29 500	1 990	10 400	8 500	0,543	3306-BD-XL-TVH
	72	30,2	43 000	29 500	1 990	7 800	8 500	0,54	3306-BD-XL-2Z-TVH
72	30,2	43 000	29 500	1 990	7 800	–	0,549	3306-BD-XL-2HRS-TVH	
35	47	10	6 500	6 800	365	15 500	7 400	0,039	3807-B-TVH
	47	10	6 500	6 800	365	11 700	7 400	0,041	3807-B-2RZ-TVH
	47	10	6 500	6 800	365	7 000	–	0,041	3807-B-2RS-TVH
	62	20	24 000	19 100	970	11 700	8 800	0,2	3007-B-TVH
	62	20	24 000	19 100	970	8 800	8 800	0,224	3007-B-2RZ-TVH
	62	20	24 000	19 100	970	6 400	–	0,224	3007-B-2RS-TVH
	72	27	41 000	30 000	2 030	10 100	9 900	0,436	3207-BD-XL-TVH
	72	27	41 000	30 000	2 030	7 600	9 900	0,432	3207-BD-XL-2Z-TVH
	72	27	41 000	30 000	2 030	7 600	–	0,44	3207-BD-XL-2HRS-TVH
	80	34,9	50 000	41 000	2 600	9 600	7 100	0,889	3307-DA
	80	34,9	55 000	36 500	2 460	9 000	8 100	0,706	3307-BD-XL-TVH
	80	34,9	55 000	36 500	2 460	6 800	8 100	0,702	3307-BD-XL-2Z-TVH
80	34,9	55 000	36 500	2 460	6 800	–	0,717	3307-BD-XL-2HRS-TVH	

medias ► <https://www.schaeffler.de/std/1D90>

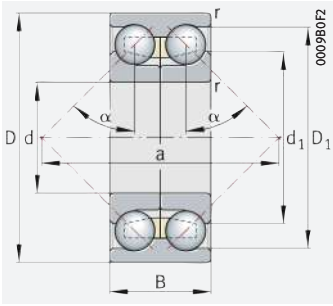

33...-DA;
split inner ring

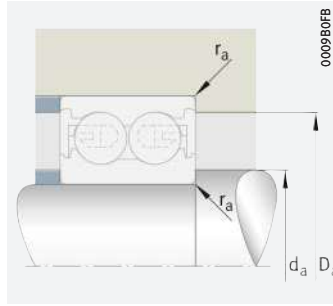

Mounting dimensions



Dimensions							Nominal contact angle	Mounting dimensions		
d	r	D ₁	D ₂	d ₁	d ₂	a		d _a	D _a	r _a
	min.	≈	≈	≈	≈	≈	°	min.	max.	max.
30	0,3	38	–	34	–	20,2	25	32	40	0,3
	0,3	–	39	–	32,9	20,2	25	32	40	0,3
	0,3	–	39	–	32,9	20,2	25	32	40	0,3
	1	46,7	–	37,3	–	27,4	25	34,6	50,4	1
	1	–	49,1	–	35,6	27,4	25	34,6	50,4	1
	1	–	49,1	–	35,6	27,4	25	34,6	50,4	1
	1	53,3	–	42,2	–	36,4	30	35,6	56,4	1
	1	–	55,8	–	40,3	36,4	30	35,6	56,4	1
	1	–	55,8	–	40,3	36,4	30	35,6	56,4	1
	1,1	61,5	–	48,2	–	41,9	45	37	65	1
	1,1	60,5	–	46,3	–	41,9	30	37	65	1
	1,1	–	63,5	–	44,4	41,9	30	37	65	1
1,1	–	63,5	–	44,4	41,9	30	37	65	1	
35	0,3	43	–	39	–	22,6	25	37	45	0,3
	0,3	–	44,1	–	37,6	22,6	25	37	45	0,3
	0,3	–	44,1	–	37,6	22,6	25	37	45	0,3
	1	53,3	–	43,7	–	30,9	25	39,6	57,4	1
	1	–	55,3	–	40,5	30,9	25	39,6	57,4	1
	1	–	55,3	–	40,5	30,9	25	39,6	57,4	1
	1,1	62,4	–	49,1	–	42,5	30	42	65	1
	1,1	–	65,4	–	46,9	42,5	30	42	65	1
	1,1	–	65,4	–	46,9	42,5	30	42	65	1
	1,5	69,5	–	55,2	–	48	45	44	71	1,5
	1,5	68,9	–	51,8	–	48	30	44	71	1,5
	1,5	–	71,9	–	49,6	48	30	44	71	1,5
1,5	–	71,9	–	49,6	48	30	44	71	1,5	

Angular contact ball bearings

Double row

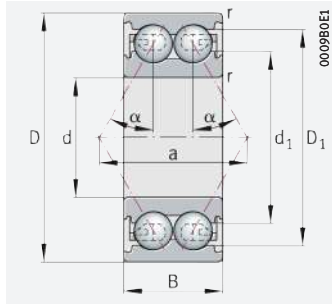

38..-B, 30..-B, 32..-B, 33..-B,
32..-BD, 33..-BD, 32, 33

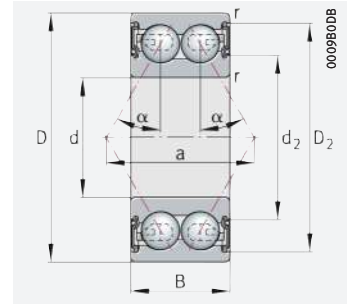

38..-B, 30..-B, 32..-B, 33..-B,
32..-BD, 33..-BD;
with seal 2HRS, 2RS, 2RSR, 2RZ, 2Z

d = 40 – 50 mm

Main dimensions			Basic load ratings		Fatigue limit load C_{ur}	Limiting speed n_G	Speed rating $n_{\theta r}$	Mass m	Designation
d	D	B	dyn. C_r	stat. C_{0r}					
			N	N	N	min^{-1}	min^{-1}	≈ kg	
40	52	10	6 900	7 600	415	13 700	6 300	0,044	3808-B-TVH
	52	10	6 900	7 600	415	10 300	6 300	0,046	3808-B-2RZ-TVH
	52	10	6 900	7 600	415	6 100	–	0,046	3808-B-2RS-TVH
	68	21	25 000	21 300	1 080	10 600	8 000	0,25	3008-B-TVH
	68	21	25 000	21 300	1 080	8 000	8 000	0,25	3008-B-2RZ-TVH
	68	21	25 000	21 300	1 080	5 600	–	0,25	3008-B-2RS-TVH
	80	30,2	51 000	38 000	2 550	8 900	9 100	0,591	3208-BD-XL-TVH
	80	30,2	51 000	38 000	2 550	6 700	9 100	0,58	3208-BD-XL-2Z-TVH
	80	30,2	51 000	38 000	2 550	6 700	–	0,597	3208-BD-XL-2HRS-TVH
	90	36,5	62 000	52 000	3 250	10 700	6 000	1,2	3308-DA-MA
	90	36,5	67 000	48 500	3 250	8 000	7 000	0,969	3308-BD-XL-TVH
90	36,5	67 000	48 500	3 250	6 000	7 000	0,967	3308-BD-XL-2Z-TVH	
90	36,5	67 000	48 500	3 250	6 000	–	0,985	3308-BD-XL-2HRS-TVH	
45	58	10	7 000	8 100	455	12 400	5 700	0,055	3809-B-TVH
	58	10	7 000	8 100	455	9 300	5 700	0,058	3809-B-2RZ-TVH
	58	10	7 000	8 100	455	5 500	–	0,058	3809-B-2RS-TVH
	85	30,2	50 000	39 000	2 650	8 300	8 400	0,622	3209-BD-XL-TVH
	85	30,2	50 000	39 000	2 650	6 300	8 400	0,618	3209-BD-XL-2Z-TVH
	85	30,2	50 000	39 000	2 650	6 300	–	0,626	3209-BD-XL-2HRS-TVH
	100	39,7	71 000	64 000	3 500	7 500	5 800	1,55	3309-DA
	100	39,7	72 000	54 000	3 600	7 300	6 700	1,335	3309-BD-XL-TVH
100	39,7	72 000	54 000	3 600	5 500	6 700	1,315	3309-BD-XL-2Z-TVH	
100	39,7	72 000	54 000	3 600	5 500	–	1,314	3309-BD-XL-2HRS-TVH	
50	65	12	8 500	10 200	570	10 900	5 400	0,09	3810-B-TVH
	65	12	8 500	10 200	570	8 100	5 400	0,093	3810-B-2RZ-TVH
	65	12	8 500	10 200	570	4 800	–	0,093	3810-B-2RS-TVH
	90	30,2	53 000	44 000	3 000	7 800	7 600	0,672	3210-BD-XL-TVH
	90	30,2	53 000	44 000	3 000	5 900	7 600	0,667	3210-BD-XL-2Z-TVH
	90	30,2	53 000	44 000	3 000	5 900	–	0,668	3210-BD-XL-2HRS-TVH
	110	44,4	90 000	84 000	5 200	8 700	5 300	2,24	3310-DA-MA
	110	44,4	93 000	70 000	4 700	6 500	6 300	1,749	3310-BD-XL-TVH
	110	44,4	93 000	70 000	4 700	4 900	6 300	1,75	3310-BD-XL-2Z-TVH
	110	44,4	93 000	70 000	4 700	4 900	–	1,748	3310-BD-XL-2HRS-TVH

medias ► <https://www.schaeffler.de/std/1D91>

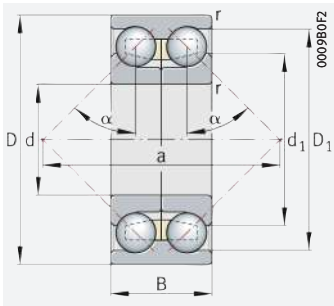

33...-DA;
split inner ring

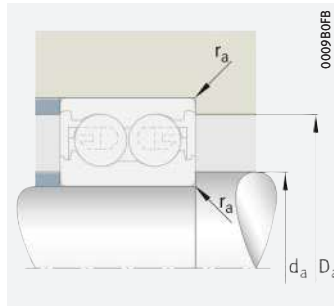

Mounting dimensions



Dimensions							Nominal contact angle α	Mounting dimensions		
d	r	D ₁	D ₂	d ₁	d ₂	a		d _a	D _a	r _a
	min.	≈	≈	≈	≈	≈	°	min.	max.	max.
40	0,3	48,5	–	44,6	–	25,2	25	42	50	0,3
	0,3	–	49,6	–	43,5	25,2	25	42	50	0,3
	0,3	–	49,6	–	43,5	25,2	25	42	50	0,3
	1	58,8	–	49,2	–	33,4	25	44,6	63,4	1
	1	–	61,2	–	46,7	33,4	25	44,6	63,4	1
	1	–	61,2	–	46,7	33,4	25	44,6	63,4	1
	1,1	69,6	–	54,9	–	47,4	30	47	73	1
	1,1	–	72,6	–	52,8	47,4	30	47	73	1
	1,1	–	72,6	–	52,8	47,4	30	47	73	1
	1,5	79,7	–	61,7	–	85	45	49	81	1,5
	1,5	77	–	59	–	53,1	30	49	81	1,5
	1,5	–	79,9	–	56,8	53,1	30	49	81	1,5
1,5	–	79,9	–	56,8	53,1	30	49	81	1,5	
45	0,3	53,6	–	49,6	–	27,5	25	47	56	0,3
	0,3	–	54,6	–	48,1	27,5	25	47	56	0,3
	0,3	–	54,6	–	48,1	27,5	25	47	56	0,3
	1,1	75,1	–	59,9	–	50,3	30	52	78	1
	1,1	–	78,1	–	57,7	50,3	30	52	78	1
	1,1	–	78,1	–	57,7	50,3	30	52	78	1
	1,5	86,7	–	68,3	–	93	45	54	91	1,5
	1,5	84,4	–	65,5	–	57,8	30	54	91	1,5
	1,5	–	87,3	–	63,3	57,8	30	54	91	1,5
	1,5	–	87,3	–	63,3	57,8	30	54	91	1,5
50	0,3	60,7	–	56,3	–	31	25	52	63	0,3
	0,3	–	61,7	–	55,2	31	25	52	63	0,3
	0,3	–	61,7	–	55,2	31	25	52	63	0,3
	1,1	80,1	–	64,9	–	53,2	30	57	83	1
	1,1	–	82,9	–	62,8	53,2	30	57	83	1
	1,1	–	82,9	–	62,8	53,2	30	57	83	1
	2	96,9	–	77,3	–	104	45	61	99	2
	2	93,3	–	71,5	–	64,2	30	61	99	2
	2	–	96,8	–	69,1	64,2	30	61	99	2
2	–	96,8	–	69,1	64,2	30	61	99	2	



Angular contact ball bearings

Double row

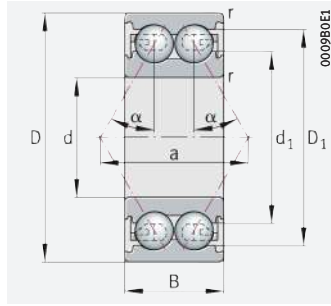

38...-B, 30...-B, 32...-B, 33...-B,
32...-BD, 33...-BD, 32, 33

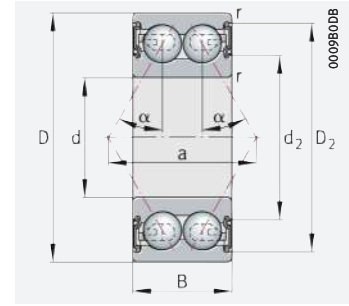

38...-B, 30...-B, 32...-BD, 33...-BD;
with seal 2HRS, 2RS, 2RZ, 2Z

d = 55 – 65 mm

Main dimensions			Basic load ratings		Fatigue limit load	Limiting speed	Speed rating	Mass	Designation
d	D	B	dyn. C_r	stat. C_{0r}	C_{ur}	n_G	$n_{\theta r}$	m	▶ 322 2.12 ▶ 322 2.13 X-life ▶ 316
			N	N	N	min^{-1}	min^{-1}	≈ kg	
55	72	13	10 700	13 100	730	9 600	4 850	0,13	3811-B-TVH
	72	13	10 700	13 100	730	7 200	4 850	0,134	3811-B-2RZ-TVH
	72	13	10 700	13 100	730	4 300	–	0,134	3811-B-2RS-TVH
	100	33,3	61 000	51 000	3 450	7 100	7 200	0,94	3211-BD-XL-TVH
	100	33,3	61 000	51 000	3 450	5 300	7 200	0,93	3211-BD-XL-2Z-TVH
	100	33,3	61 000	51 000	3 450	5 300	–	0,933	3211-BD-XL-2HRS-TVH
	120	49,2	105 000	101 000	5 400	8 000	5 200	2,85	3311-DA-MA
	120	49,2	116 000	88 000	6 000	5 800	5 900	2,28	3311-BD-XL-TVH
	120	49,2	116 000	88 000	6 000	4 350	5 900	2,265	3311-BD-XL-2Z-TVH
	120	49,2	116 000	88 000	6 000	4 350	–	2,264	3311-BD-XL-2HRS-TVH
60	78	14	14 200	17 100	940	8 800	4 700	0,161	3812-B-TVH
	78	14	14 200	17 100	940	6 600	4 700	0,166	3812-B-2RZ-TVH
	78	14	14 200	17 100	940	4 050	–	0,166	3812-B-2RS-TVH
	110	36,5	75 000	64 000	4 300	6 300	6 700	1,25	3212-BD-XL-TVH
	110	36,5	75 000	64 000	4 300	4 750	6 700	1,24	3212-BD-XL-2Z-TVH
	110	36,5	75 000	64 000	4 300	4 750	–	1,25	3212-BD-XL-2HRS-TVH
	130	54	121 000	118 000	6 500	5 500	4 850	3,39	3312-DA
	130	54	126 000	103 000	5 200	3 950	5 000	2,85	3312-B-TVH
	130	54	126 000	103 000	5 200	3 950	5 000	2,92	3312-B-2Z-TVH
	130	54	126 000	103 000	5 200	3 300	–	2,92	3312-B-2RSR-TVH
65	120	38,1	86 000	77 000	5 200	5 700	6 000	1,604	3213-BD-XL-TVH
	120	38,1	86 000	77 000	5 200	4 300	6 000	1,602	3213-BD-XL-2Z-TVH
	120	38,1	86 000	77 000	5 200	4 300	–	1,6	3213-BD-XL-2HRS-TVH
	140	58,7	139 000	137 000	7 200	5 100	4 650	4,384	3313-DA
	140	58,7	150 000	119 000	7 900	4 900	5 300	4,1	3313-BD-XL-TVH
	140	58,7	150 000	119 000	7 900	3 650	5 300	4,1	3313-BD-XL-2Z-TVH

medias ▶ <https://www.schaeffler.de/std/1D92>

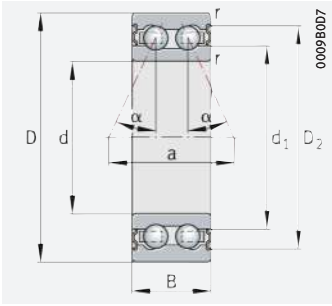

32..-B, 33..-B;
with seal 2RSR, 2Z

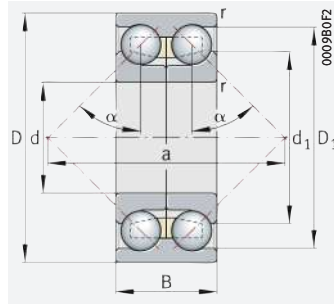

33..-DA;
split inner ring

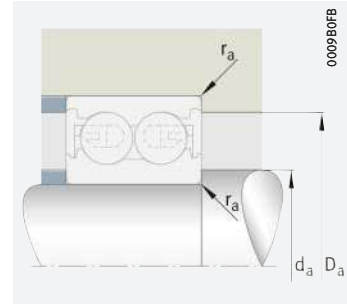

Mounting dimensions



Dimensions							Nominal contact angle	Mounting dimensions		
d	r	D ₁	D ₂	d ₁	d ₂	a		d _a	D _a	r _a
	min.	≈	≈	≈	≈	≈	°	min.	max.	max.
55	0,3	68	–	63,1	–	34,9	25	57	70	0,3
	0,3	–	69,1	–	61,4	34,9	25	57	70	0,3
	0,3	–	69,1	–	61,4	34,9	25	57	70	0,3
	1,5	87,8	–	71,6	–	58,4	30	64	91	1,5
	1,5	–	90,8	–	69,2	58,4	30	64	91	1,5
	1,5	–	90,8	–	69,2	58,4	30	64	91	1,5
	2	105,3	–	81,6	–	111	45	66	109	2
	2	103,3	–	78,8	–	71,4	30	66	109	2
60	0,3	73	–	67,1	–	38,1	25	62	76	0,3
	0,3	–	74,8	–	67,3	38,1	25	62	76	0,3
	0,3	–	74,8	–	67,3	38,1	25	62	76	0,3
	1,5	97	–	79	–	64,7	30	69	101	1,5
	1,5	–	100,5	–	76,6	64,7	30	69	101	1,5
	1,5	–	100,5	–	76,6	64,7	30	69	101	1,5
	2,1	115,8	–	91,9	–	122	45	72	118	2,1
	2,1	108,7	–	81,6	–	67,3	25	72	118	2,1
65	1,5	106,6	–	87,7	–	70,6	30	74	111	1,5
	1,5	–	110,1	–	85,3	70,6	30	74	111	1,5
	1,5	–	110,1	–	85,3	70,6	30	74	111	1,5
	2,1	124,1	–	98,4	–	131	45	77	128	2,1
	2,1	120,5	–	93,4	–	83,49	30	77	128	2,1
	2,1	–	125	–	90,6	83,49	30	77	128	2,1

Angular contact ball bearings

Double row

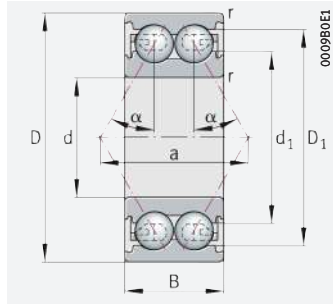

38..-B, 30..-B, 32..-B, 33..-B,
32..-BD, 33..-BD, 32, 33

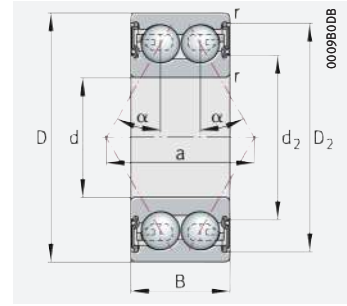

38..-B, 30..-B, 32..-BD, 33..-BD;
with seal 2HRS, 2RS, 2RZ, 2Z

d = 70 – 85 mm

Main dimensions			Basic load ratings		Fatigue limit load	Limiting speed	Speed rating	Mass	Designation
d	D	B	dyn. C_r	stat. C_{0r}	C_{ur}	n_G	$n_{\theta r}$	m	
			N	N	N	min^{-1}	min^{-1}	≈ kg	▶ 322 2.12 ▶ 322 2.13 X-life ▶ 316
70	90	15	18 800	23 200	1 280	7 500	4 050	0,2	3814-B-TVH
	90	15	18 800	23 200	1 280	5 700	4 050	0,205	3814-B-2RZ-TVH
	90	15	18 800	23 200	1 280	3 450	–	0,205	3814-B-2RS-TVH
	125	39,7	82 000	79 000	4 000	4 150	5 600	1,78	3214-B-TVH
	125	39,7	82 000	79 000	4 000	4 150	5 600	1,78	3214-B-2Z-TVH
	125	39,7	82 000	79 000	4 000	3 100	–	1,78	3214-B-2RSR-TVH
	150	63,5	157 000	157 000	8 200	4 800	4 550	5,359	3314-DA
	150	63,5	172 000	135 000	8 700	4 550	5 100	4,499	3314-BD-XL-TVH
	150	63,5	172 000	135 000	8 700	3 400	5 100	4,5	3314-BD-XL-2Z-TVH
	150	63,5	167 000	176 000	8 500	4 750	4 500	4,89	3314
75	130	41,3	88 000	85 000	4 250	3 900	5 300	1,907	3215-B-TVH
	130	41,3	88 000	85 000	4 250	3 900	5 300	1,94	3215-B-2Z-TVH
	130	41,3	88 000	85 000	4 250	2 900	–	1,939	3215-B-2RSR-TVH
	160	68,3	184 000	179 000	10 000	5 800	4 350	5,904	3315-DA-MA
	160	68,3	192 000	209 000	9 700	4 400	4 250	6,16	3315
80	100	15	19 200	24 800	1 390	6 800	3 650	0,22	3816-B-TVH
	100	15	19 200	24 800	1 390	5 100	3 650	0,23	3816-B-2RZ-TVH
	100	15	19 200	24 800	1 390	3 100	–	0,23	3816-B-2RS-TVH
	140	44,4	99 000	102 000	4 950	3 650	5 100	2,403	3216-B-TVH
	140	44,4	99 000	102 000	4 950	3 650	5 100	2,48	3216-B-2Z-TVH
	140	44,4	99 000	102 000	4 950	2 700	–	2,48	3216-B-2RSR-TVH
	170	68,3	192 000	196 000	9 600	5 400	3 900	7,879	3316-DA-MA
	170	68,3	199 000	180 000	10 700	3 950	4 300	6,4	3316-BD-XL-TVH
	170	68,3	199 000	180 000	10 700	2 950	–	6,3	3316-BD-XL-2HRS-TVH
	170	68,3	208 000	226 000	10 300	4 150	3 900	6,785	3316
85	150	49,2	135 000	127 000	5 900	3 350	4 900	3	3217-B-TVH
	150	49,2	135 000	127 000	5 900	3 350	4 900	3,3	3217-B-2Z-TVH
	150	49,2	135 000	127 000	5 900	2 600	–	3,3	3217-B-2RS-TVH
	150	49,2	128 000	154 000	7 200	4 650	4 700	3,32	3217
	180	73	229 000	255 000	11 100	5 000	3 600	8,46	3317-M
	180	73	209 000	221 000	10 700	5 200	3 750	9,39	3317-DA-MA

medias ▶ <https://www.schaeffler.de/std/1D93>

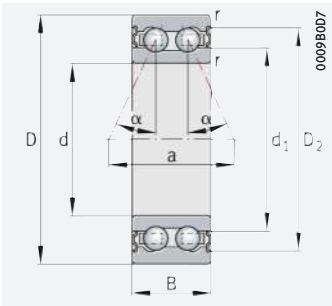

32...-B, 33...-B;
with seal 2RSR, 2Z

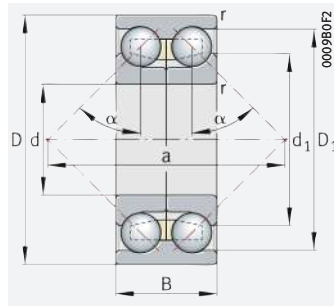

33...-DA;
split inner ring

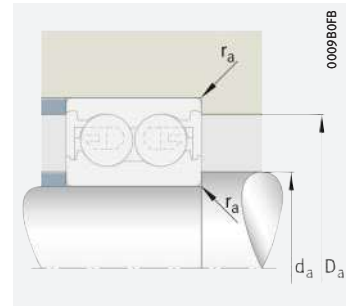

Mounting dimensions

Dimensions							Nominal contact angle α	Mounting dimensions		
d	r	D ₁	D ₂	d ₁	d ₂	a		d _a min.	D _a max.	r _a max.
	min.	≈	≈	≈	≈	≈	°			
70	0,6	84,5	–	77,7	–	43,6	25	73,2	86,8	0,6
	0,6	–	86,3	–	76,6	43,6	25	73,2	86,8	0,6
	0,6	–	86,3	–	76,6	43,6	25	73,2	86,8	0,6
	1,5	106,3	–	87	–	61,6	25	79	116	1,5
	1,5	–	110,7	86,8	–	61,6	25	79	116	1,5
	1,5	–	110,7	86,8	–	61,6	25	79	116	1,5
	2,1	132,4	–	103,4	–	141	45	82	138	2,1
	2,1	129,2	–	100,3	–	89,409	30	82	138	2,1
	2,1	–	133,7	–	96,9	89,409	30	82	138	2,1
2,1	131,9	–	98,5	–	109,02	35	82	138	2,1	
75	1,5	112,6	–	92,4	–	65,2	25	84	121	1,5
	1,5	–	115,5	92,1	–	65,2	25	84	121	1,5
	1,5	–	115,5	92,1	–	65,2	25	84	121	1,5
	2,1	141,3	–	109,3	–	150	45	87	148	2,1
	2,1	141,2	–	105,5	–	116,6	35	87	148	2,1
80	0,6	93,5	–	86,7	–	47,8	25	83,2	96,8	0,6
	0,6	–	95,3	–	85,5	47,8	25	83,2	96,8	0,6
	0,6	–	95,3	–	85,5	47,8	25	83,2	96,8	0,6
	2	120,3	–	98,8	–	69,13	25	91	129	2
	2	–	124,5	98,5	–	69,13	25	91	129	2
	2	–	124,5	98,5	–	69,13	25	91	129	2
	2,1	149,9	–	118,7	–	159	45	92	158	2,1
	2,1	148	–	116,7	–	100,8	30	92	158	2,1
	2,1	–	151,9	–	114	100,8	30	92	158	2,1
	2,1	149,7	–	111,8	–	122,53	35	92	158	2,1
85	2	130,4	–	105	–	75,9	25	96	139	2
	2	–	135,1	–	102,3	75,9	25	96	139	2
	2	–	135,1	–	102,3	75,9	25	96	139	2
	2	135,1	–	108,5	–	106,3	35	96	139	2
	3	160	–	119,6	–	131,48	35	99	166	2,5
	3	156,5	–	124,3	–	167	45	99	166	2,5



Angular contact ball bearings

Double row

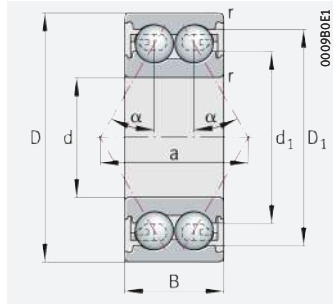

38..-B, 30..-B, 32..-B, 33..-B, 32..-BD, 33..-BD, 32, 33

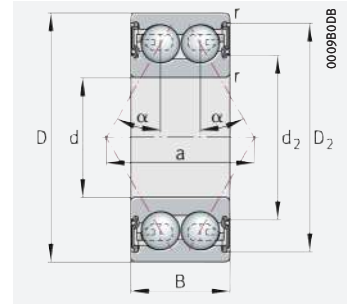

38..-B, 30..-B, 32..-BD, 33..-BD; with seal 2HRS, 2RS, 2RZ, 2Z

d = 90 – 110 mm

Main dimensions			Basic load ratings		Fatigue limit load C_{ur} N	Limiting speed n_G min^{-1}	Speed rating $n_{\theta r}$ min^{-1}	Mass m \approx kg	Designation ▶ 322 2.12 ▶ 322 2.13 X-life ▶ 316
d	D	B	dyn. C_r N	stat. C_{0r} N					
90	115	19	27 000	35 500	1 940	5 900	3 550	0,41	3818-B-TVH
	115	19	27 000	35 500	1 940	2 750	–	0,422	3818-B-2RS-TVH
	160	52,4	142 000	142 000	6 300	4 100	4 500	3,8	3218-B-TVH
	160	52,4	142 000	142 000	6 300	2 370	–	4	3218-B-2RS-TVH
	160	52,4	143 000	172 000	7 800	4 350	4 550	4,14	3218
	190	73	226 000	247 000	11 300	4 850	3 450	10,41	3318-DA-MA
	190	73	260 000	295 000	12 600	3 650	3 350	9,14	3318
95	170	55,6	161 000	193 000	8 500	5 300	4 350	5,06	3219-M
	200	77,8	270 000	315 000	13 100	4 450	3 200	11,21	3319-M
100	125	19	28 000	39 000	2 060	5 300	3 100	0,45	3820-B-TVH
	125	19	28 000	39 000	2 060	2 470	–	0,463	3820-B-2RS-TVH
	180	60,3	185 000	173 000	7 400	3 650	4 400	5,4	3220-B-TVH
	180	60,3	185 000	173 000	7 400	2 750	4 400	5,5	3220-B-2Z-TVH
	180	60,3	185 000	173 000	7 400	2 210	–	5,5	3220-B-2RS-TVH
	180	60,3	186 000	235 000	10 000	3 750	4 050	5,975	3220
	215	82,6	285 000	340 000	13 700	4 200	3 000	14,03	3320-M
	215	82,6	260 000	305 000	13 200	4 300	3 050	15,61	3320-DA-MA
105	190	65,1	215 000	270 000	11 100	4 600	3 850	7,4	3221-M
110	200	69,8	236 000	290 000	11 900	4 400	3 750	9,03	3222-M
	240	92,1	330 000	425 000	16 300	3 750	2 650	20	3322-M
	240	92,1	310 000	385 000	16 900	3 800	2 700	21,75	3322-DA-MA

medias ▶ <https://www.schaeffler.de/std/1D94>

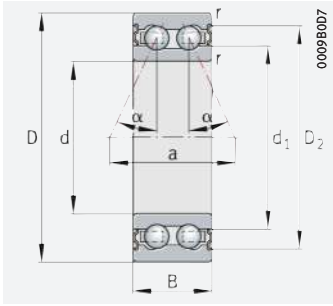

32...-B, 33...-B;
with seal 2RSR, 2Z

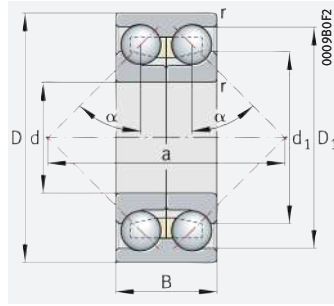

33...-DA;
split inner ring

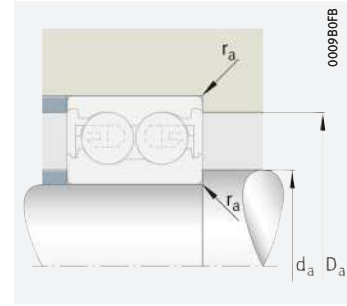

Mounting dimensions



Dimensions							Nominal contact angle α	Mounting dimensions		
d	r	D ₁	D ₂	d ₁	d ₂	a		d _a	D _a	r _a
	min.	≈	≈	≈	≈	≈	°	min.	max.	max.
90	1	106,6	–	98,44	–	55	25	94,6	110,4	1
	1	–	107,2	–	96,2	55	25	94,6	110,4	1
	2	141,6	–	116,4	–	81,4	25	104	146	2
	2	–	145,2	–	112,1	81,4	25	104	146	2
	2	143,7	–	115,6	–	112,5	35	104	146	2
	3	166,2	–	131,9	–	177	45	104	176	2,5
95	3	168,2	–	126,1	–	136,03	35	104	176	2,5
	2,1	152,8	–	122,2	–	119,8	35	107	158	2,1
100	3	177,3	–	133	–	143,28	35	109	186	2,5
	1	117,9	–	109,54	–	60,2	25	104,6	120,4	1
	1	–	118,5	–	107,3	60,2	25	104,6	120,4	1
	2,1	155,7	–	124,7	–	91,3	25	112	168	2,1
	2,1	–	157,4	–	121,3	91,3	25	112	168	2,1
	2,1	–	157,4	–	121,3	91,3	25	112	168	2,1
	2,1	163,7	–	131	–	127,43	35	112	168	2,1
105	3	188,7	–	142,5	–	153,28	35	114	201	2,5
	3	187,1	–	147,5	–	197,5	45	114	201	2,5
110	2,1	172,1	–	138	–	134,68	35	117	178	2,1
	2,1	180,1	–	143,3	–	143,5	35	122	188	2,1
	3	209,6	–	161,54	–	170,54	35	124	226	2,5
	3	207,3	–	164,5	–	221	45	124	226	2,5

Four point contact bearings



Matrix for bearing preselection 349

1 Four point contact bearings **350**

- 1.1 Bearing design 350
- 1.2 Load carrying capacity 352
- 1.3 Compensation of angular misalignments 352
- 1.4 Lubrication 353
- 1.5 Sealing 353
- 1.6 Speeds 353



1.7	Noise	353	1.17	Mounting and dismounting	360
1.8	Temperature range	354	1.18	Legal notice regarding data freshness	360
1.9	Cages	355	1.19	Further information	361
1.10	Internal clearance	355	Product tables	362	
1.11	Dimensions, tolerances	356	 Four point contact bearings	362	
1.12	Suffixes	356			
1.13	Structure of bearing designation	356			
1.14	Dimensioning	357			
1.15	Minimum load	357			
1.16	Design of bearing arrangements	358			





Matrix for bearing preselection

The matrix gives an overview of the types and design features of four point contact bearings.

It can be used to make a preliminary assessment of whether a bearing is fundamentally suitable for the envisaged application.

The additional information provided in the product chapter (see column "detailed information") and in the Technical principles must, however, be observed in selection of the bearing.

Design features and suitability			Four point contact bearings	
+++ extremely suitable ++ highly suitable + suitable (+) suitable with restrictions – not suitable/not applicable ✓ available			with/without retaining slots	detailed information
Load carrying capacity	radial		(+)	▶ 352 1.2
	axial, one direction		++	▶ 352 1.2
	axial, both directions		++	▶ 352 1.2
	moments		(+)	▶ 352 1.2
Compensation of angular misalignments	static		–	▶ 352 1.3
	dynamic		–	▶ 352 1.3
Bearing design	cylindrical bore		✓	▶ 350 1.1
	tapered bore		–	
	separable		✓	▶ 360 1.17
Lubrication	greased		–	▶ 353 1.4
Sealing	open		✓	▶ 353 1.5
	non-contact		–	▶ 353 1.5
	contact		–	▶ 353 1.5
Operating temperature in °C		from to	–30 +150 ¹⁾	▶ 354 1.8
Suitability for	high speeds		(+)	▶ 353 1.6
	high running accuracy		(+)	▶ 356 1.11 ▶ 114
	low-noise running		(+)	▶ 353 1.7
	high rigidity		+	▶ 54
	reduced friction		+	▶ 56
	length compensation within bearing		–	
	non-locating bearing arrangement		–	▶ 139
	locating bearing arrangement		++	▶ 139
X-life bearings			✓	▶ 351
Bearing bore d in mm		from to	17 200 ²⁾	▶ 362
Product tables		from page		362

¹⁾ Valid for bearings with brass cages, D ≤ 240 mm
²⁾ Larger catalogue bearings
 ▶ GL 1

1 Four point contact bearings



- Four point contact bearings are particularly suitable where:
- predominantly axial loads must be supported ▶ 352 | 1.2
 - the axial design envelope is not sufficient for double row radial angular contact ball bearings
 - radial forces must be supported by a separate radial bearing ▶ 351 | 3
 - axial forces occur in both directions and a close axial guidance is required in conjunction with a small bearing width, e.g. in gearbox engineering.

For an overview of other product-specific features, see the Matrix for bearing preselection ▶ 349.

 1
Four point contact bearing and double row angular contact ball bearing – comparison of design envelope

B = bearing width

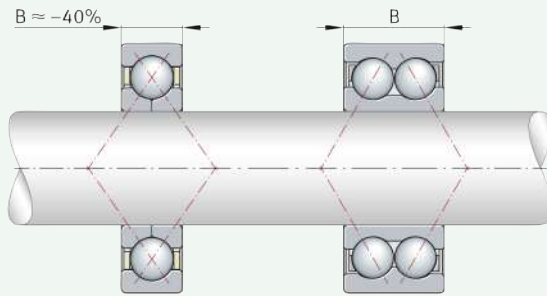

1.1 Bearing design

Design variants

- Four point contact bearings are available as:
- bearings of basic design ▶ 351 | 2
 - bearings with retaining slots in the outer ring ▶ 351 | 3
 - X-life bearings ▶ 351.

Bearings of basic design

 Comparable, in terms of product design, with single row radial angular contact ball bearings

Four point contact bearings are single row, non-self-retaining radial ball bearings. They are similar in their structure to single row radial angular contact ball bearings; the raceways on the inner rings are, however, designed such that they can support axial loads in both directions ▶ 351 | 2 and ▶ 352 | 1.2. The centre points of curvature of the arc-shaped raceways on the inner and outer ring are offset relative to each other in such a way that the balls are in contact with the bearing rings at four points under radial load ▶ 351 | 2 and ▶ 352 | 1.2.

 Smaller axial section height than double row angular contact ball bearings

These bearings have solid outer rings, split inner rings and ball and cage assemblies with brass or polyamide cages ▶ 355 | 1.9. The two-piece inner ring allows a large complement of balls to be accommodated in the bearing. The inner ring halves are matched to the particular bearing and must not be interchanged with those of other bearings of the same size. In an axial direction, four point contact bearings are considerably narrower than, for example, double row angular contact ball bearings.

2
Four point contact bearing
of basic design

α = nominal contact angle
 M_1, M_2 = centres of curvature
of outer ring raceway
 F_r = radial load
 F_a = axial load

- ① Four point contact bearing, split inner ring, without retaining slots in the outer ring
- ② Raceway geometry

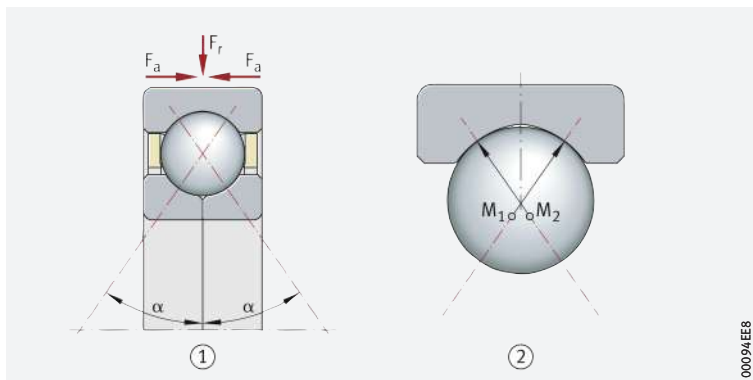

00094EEB

Bearings with retaining slots in the outer ring

The retaining slots allow simple location of the bearing in the housing

Four point contact bearings are often combined with a radial bearing and used as an axial bearing with radial clearance in a housing [▶ 351 | 3](#), [▶ 358 | 1.16](#). For quick and secure location of the bearings in the housing, larger bearings therefore have two retaining slots in one end face of the outer ring offset by 180° [▶ 351 | 3](#). Locking pins engage in these retaining slots and locate the outer ring in the housing.

3
Four point contact bearing used as an axial bearing, radial clearance on outer ring, axial force flow

- ① Cylindrical roller bearing (radial bearing)
- ② Four point contact bearing with retaining slots in outer ring (axial bearing, outer ring not radially retained)
- ③ Locking pin for location of outer ring

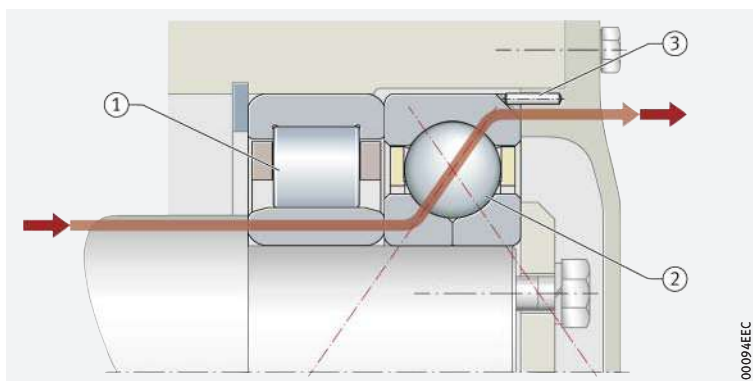

00094EEC



X-life premium quality

Four point contact bearings are available in certain sizes as X-life bearings. These bearings exhibit considerably higher performance than standard four point contact bearings [▶ 352 | 4](#). This is achieved, for example, through the modified internal construction, higher surface quality of the contact surfaces and optimised cage design, as well as through the improved quality of the steel and rolling elements.

Advantages

The technical enhancements offer a range of advantages, such as:

Increased customer benefits due to X-life

- a more favourable load distribution in the bearing and thus a higher dynamic load carrying capacity of the bearings [▶ 286 | 6](#)
- quieter running
- running with reduced friction and greater energy efficiency
- lower heat generation in the bearing
- higher possible speeds
- lower lubricant consumption and, consequently, longer maintenance intervals
- a measurably longer operating life
- high operational security
- compact, environmentally-friendly bearing arrangements.

Lower operating costs,
higher machine availability

Suffix XL

In conclusion, these advantages improve the overall cost-efficiency of the bearing position significantly and thus bring about a sustainable increase in the efficiency of the machine and equipment.

X-life four point contact bearings include the suffix XL in the designation
 ▶ 356 | 4, ▶ 356 | 6 and ▶ 362 | 6.

4
 Comparison of basic dynamic load rating C_r – bearing series QJ3...-XL, bore code 5 to 14, with a bearing which is not of X-life quality

C_r = basic dynamic load rating

① Bore code

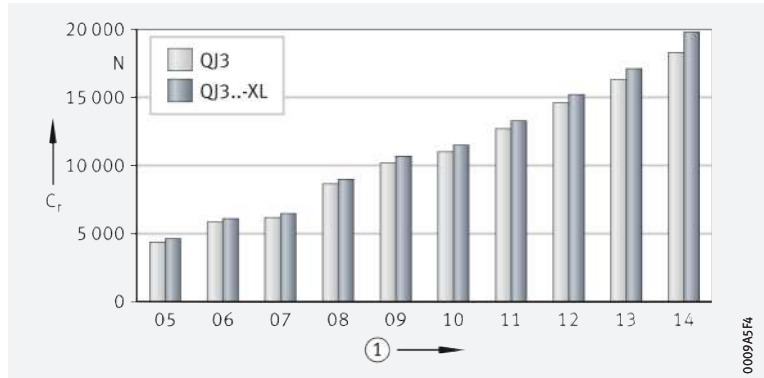

Wide application range

Areas of application

Due to their special technical features, X-life four point contact bearings are highly suitable for bearing arrangements in:

- compressors
- fluid and hydraulic pumps
- automotive chassis and gearboxes
- gearboxes for industrial, rail and wind turbine applications
- agricultural vehicles and equipment.



X-life indicates a high product performance density and thus a particularly significant benefit to the customer. Further information on X-life ▶ 10.

1.2 Load carrying capacity

Capable of supporting high axial loads in both directions

Due to the design of the raceways with their high shoulders, the large nominal contact angle of $\alpha_0 = 35^\circ$ and the large number of rolling elements, four point contact bearings have a very high axial load carrying capacity. They are suitable for alternating, purely axial loads or predominantly axial load. The balls are in contact with the inner ring and outer ring each at one point only, as is the case with a single row angular contact ball bearing under axial load ▶ 351 | 2.



The radial load carrying capacity of the bearings is low. If predominantly radial load is present, four point contact bearings should not be used due to the higher friction in the four point contact.

1.3 Compensation of angular misalignments

Four point contact bearings cannot compensate misalignments

Four point contact bearings are not suitable for the compensation of angular misalignments due to housing deformations or shaft deflections. The possible skewing of the inner ring in relation to the outer ring depends, for example, on the bearing load, the operating clearance and the bearing size, and is very small.



Skewing of the bearing rings increases the running noise, places increased strain on the cages and has a harmful influence on the operating life of the bearings.

1.4 Lubrication

- ☞ *Oil or grease lubrication* The bearings are not greased. They must be lubricated with oil or grease.
- ☞ *Compatibility with plastic cages* When using bearings with plastic cages, compatibility between the lubricant and the cage material must be ensured if synthetic oils, lubricating greases with a synthetic oil base or lubricants containing a high proportion of EP additives are used.
- ☞ *Observe oil change intervals* Aged oil and additives in the oil can impair the operating life of plastics at high temperatures. As a result, stipulated oil change intervals must be strictly observed.

1.5 Sealing

- ☞ *The bearings are of an open design* Four point contact bearings are supplied without seals. As a result, sealing of the bearing position must be carried out in the adjacent construction. The sealing system should reliably prevent:
 - moisture and contaminants from entering the bearing
 - the egress of lubricant from the bearing.

1.6 Speeds

- ☞ *Higher speeds are only possible under purely axial load* Due to the four point contact and resulting higher level of friction, the speed suitability of the bearings is heavily restricted under radial load. Higher speeds can only be achieved if four point contact ball bearings are subjected to purely axial load.
- ☞ *Limiting speeds and reference speeds in the product tables* Two speeds are generally indicated in the product tables ▶ 362|:
 - the kinematic limiting speed n_G
 - the thermal speed rating $n_{\vartheta r}$.

Limiting speed



The limiting speed n_G is the kinematically permissible speed of a bearing. Even under favourable mounting and operating conditions, this value should not be exceeded without prior consultation with Schaeffler ▶ 64. The values in the product tables are valid for oil lubrication.

- ☞ *Values for grease lubrication* For grease lubrication, 75% of the value stated in the product tables is permissible in each case.

Reference speeds

- ☞ *$n_{\vartheta r}$ is used to calculate n_{ϑ}* The thermal speed rating $n_{\vartheta r}$ is not an application-oriented speed limit, but is a calculated ancillary value for determining the thermally safe operating speed n_{ϑ} ▶ 64.

1.7 Noise

The Schaeffler Noise Index (SGI) has been developed as a new feature for comparing the noise level of different bearing types and series. As a result, a noise evaluation of rolling bearings can now be carried out for the first time.

Schaeffler Noise Index

The SGI value is based on the maximum permissible noise level of a bearing in accordance with internal standards, which is calculated on the basis of ISO 15242. In order that different bearing types and series can be compared, the SGI value is plotted against the basic static load rating C_0 .

This permits direct comparisons between bearings with the same load carrying capacity. The upper limit value is given in each of the diagrams. This means that the average noise level of the bearings is lower than illustrated in the diagram.



 The Schaeffler Noise Index is an additional performance characteristic in the selection of bearings for noise-sensitive applications. The specific suitability of a bearing for an application in terms of installation space, load carrying capacity or speed limit for example, must be checked independently of this.

 The Noise Index is currently available for the main series. Additional series will be updated and introduced in subsequent publications.

Further information:

■ **medias** > <https://medias.schaeffler.com>.

 **5**
Schaeffler Noise Index
for four point contact bearings

SGI = Schaeffler Noise Index
 C_0 = basic static load rating

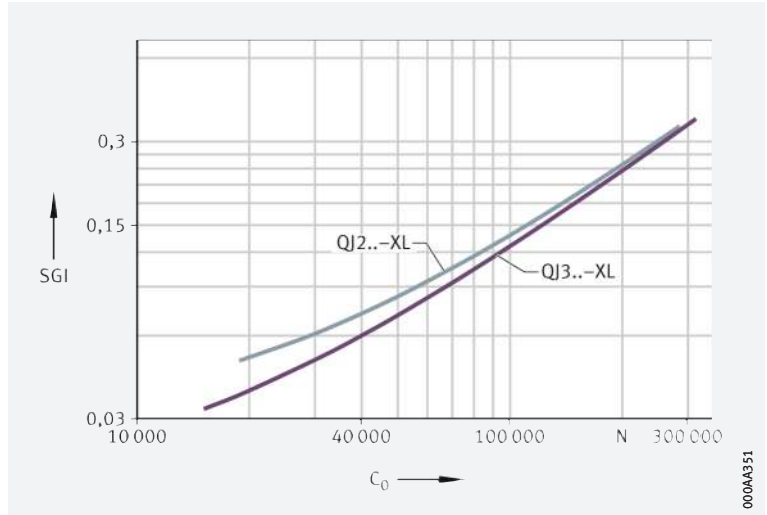

1.8 Temperature range

 **Limiting values**

The operating temperature of the bearings is limited by:

- the dimensional stability of the bearing rings and rolling elements
- the cage
- the lubricant.

Possible operating temperatures of four point contact bearings
> 354 |  1.

 **1**
Permissible temperature ranges

Operating temperature	Four point contact bearings	
	with brass cage	with polyamide cage PA66
	-30 °C to +150 °C, for D > 240 mm up to +200 °C	-30 °C to +120 °C



In the event of anticipated temperatures which lie outside the stated values, please contact Schaeffler.

1.9 Cages

☞ *Solid cages made from brass and polyamide PA66 are used as standard*

Standard cages and additional designs for four point contact bearings ▶ 355 | 2. Other cage designs are available by agreement. With such cages, however, suitability for high speeds and temperatures as well as the basic load ratings may differ from the values for the bearings with standard cages.



For high continuous temperatures and applications with difficult operating conditions, bearings with brass or sheet steel cages should be used. If there is any uncertainty regarding cage suitability, please consult Schaeffler.



Cage, cage suffix, bore code

Bearing series	Solid brass cage		Solid cage made from polyamide PA66	
	MPA		TVP	
	standard	also available for	standard	also available for
Bore code				
QJ10	12, 17, 19, 21, 22, 24, 26, 30 to 40	–	–	–
QJ2	up to 08, 10, 13, 16, 17, from 19	09, 11, 12, 14, 15, 18	09, 11, 12, 14, 15, 18	08
QJ3	03, 04, from 10	05 to 09	05 to 09	–

1.10 Internal clearance

☞ *The standard is CN*

Axial internal clearance

Four point contact bearings are manufactured as standard with axial internal clearance CN (normal) ▶ 355 | 3. CN is not stated in the designation.



Certain sizes are also available by agreement with the smaller internal clearance C2 and with the larger internal clearance C3 and C4.



The values for axial internal clearance correspond to DIN 628-4:2008 (ISO 5753-2:2010) ▶ 355 | 3. They are valid for bearings which are free from load and measurement forces (without elastic deformation).



Axial internal clearance of four point contact bearings

Nominal bore diameter d		Axial internal clearance							
		C2 (Group 2) μm		CN (Group N) μm		C3 (Group 3) μm		C4 (Group 4) μm	
over	incl.	min.	max.	min.	max.	min.	max.	min.	max.
10	18	15	65	50	95	85	130	120	165
18	40	25	75	65	110	100	150	135	185
40	60	35	85	75	125	110	165	150	200
60	80	45	100	85	140	125	175	165	215
80	100	55	110	95	150	135	190	180	235
100	140	70	130	115	175	160	220	205	265
140	180	90	155	135	200	185	250	235	300
180	220	105	175	155	225	210	280	260	330

1.11 Dimensions, tolerances

Dimension standards



The main dimensions of four point contact bearings correspond to DIN 628-4:2008. Nominal dimensions of four point contact bearings ▶ 362 | .

Chamfer dimensions



The limiting dimensions for chamfer dimensions correspond to DIN 620-6:2004. Overview and limiting values ▶ 135 | 7.11. Nominal value of chamfer dimension ▶ 362 | .

Tolerances



The tolerances for the dimensional and running accuracy of four point contact bearings correspond to tolerance class Normal in accordance with ISO 492:2014. Tolerance values in accordance with ISO 492 ▶ 122 | 8.

Retaining slots



The dimensions and tolerances of the retaining slots correspond to ISO 20515:2012 and DIN 628-4:2008.

1.12 Suffixes

For a description of the suffixes used in this chapter ▶ 356 | 4 and **medias** interchange ▶ <https://www.schaeffler.de/std/1D52>.

4
Suffixes and
corresponding descriptions

Suffix	Description of suffix	
C2	Axial internal clearance C2 (smaller than normal)	Special design, available by agreement
C3	Axial internal clearance C3 (larger than normal)	
C4	Axial internal clearance C4 (larger than C3)	
MPA	Solid brass cage, guided on outer ring	Standard, cage material dependent on bearing series and bore code
TVP	Solid cage made from glass fibre reinforced polyamide PA66	
XL	X-life bearing	Standard, dependent on bore code and bearing type
N2	Two retaining slots in outer ring	Standard for larger bearings

1.13 Structure of bearing designation

Example of composition of bearing designation

The designation of bearings follows a set model. For an example ▶ 356 | 6. The composition of designations is subject to DIN 623-1 ▶ 102 | 10.

6
Four point contact bearing with two retaining slots in the outer ring: designation structure

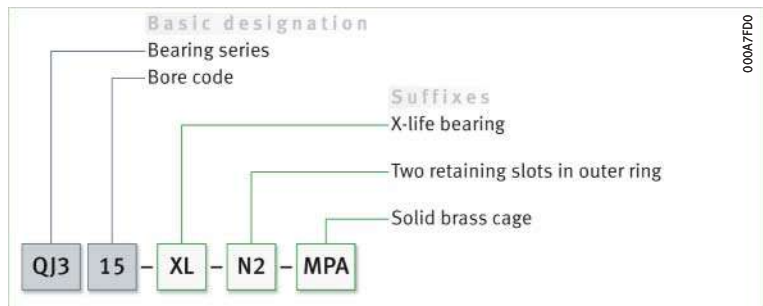

1.14 Dimensioning

☞ $P = F_r$ under purely radial load of constant magnitude and direction

☞ P is a substitute force for combined load and various load cases

☞ $F_a/F_r \leq 0,95$ or $F_a/F_r > 0,95$

Equivalent dynamic bearing load

The basic rating life equation $L = (C_r/P)^P$ used in the dimensioning of bearings under dynamic load assumes a load of constant magnitude and direction. In radial bearings, this is a purely radial load F_r . If this condition is met, the bearing load F_r is used in the rating life equation for P ($P = F_r$). If this condition is not met, a constant radial force must first be determined for the rating life calculation that (in relation to the rating life) represents an equivalent load. This force is known as the equivalent dynamic bearing load P .

The calculation of P is dependent on the load ratio F_a/F_r and the factor 0,95 ▶ 357 | f1 and ▶ 357 | f2.

f1
Equivalent dynamic load

$$\frac{F_a}{F_r} \leq 0,95 \Rightarrow P = F_r + 0,66 \cdot F_a$$

f2
Equivalent dynamic load

$$\frac{F_a}{F_r} > 0,95 \Rightarrow P = 0,6 \cdot F_r + 1,07 \cdot F_a$$

Legend

P	N	Equivalent dynamic bearing load
F_r	N	Radial load
F_a	N	Axial load.

Equivalent static bearing load

For four point contact bearings under static load ▶ 357 | f3.

f3
Equivalent static load

$$P_0 = F_{0r} + 0,58 \cdot F_{0a}$$

Legend

P_0	N	Equivalent static bearing load
F_{0r}, F_{0a}	N	Largest radial or axial load present (maximum load).

Static load safety factor

☞ $S_0 = C_0/P_0$

In addition to the basic rating life $L (L_{10h})$, it is also always necessary to check the static load safety factor S_0 ▶ 357 | f4.

f4
Static load safety factor

$$S_0 = \frac{C_0}{P_0}$$

Legend

S_0	-	Static load safety factor
C_0	N	Basic static load rating
P_0	N	Equivalent static bearing load.

1.15 Minimum load

☞ In order to prevent damage due to slippage, a minimum axial load of $F_a \geq 1,2 \cdot F_r$ is required

In order to ensure low friction in the bearing, especially at high speeds, a minimum axial load is required. In order to prevent an excessive increase in friction in the bearing, the axial force should be sufficiently high that the rolling elements are in contact with the inner and outer ring raceway at only one point. This is ensured if $F_a \geq 1,2 \cdot F_r$.





1.16 Design of bearing arrangements

 *Used as axial bearing*

If a four point contact bearing is used as a pure axial bearing, the outer ring must have a large radial clearance in the housing, in order that the bearing is not subjected to radial load **► 351** |  3.

 *Support bearing rings over their entire circumference and width*



In order to allow full utilisation of the load carrying capacity of the bearings and thus also achieve the requisite rating life, the bearing rings must be rigidly and uniformly supported by means of contact surfaces over their entire circumference and over the entire width of the raceway (not applicable to bearings with radially relieved outer rings). The seating and contact surfaces should not be interrupted by grooves, holes or other recesses. The accuracy of mating parts must meet specific requirements **► 359** |  5 to **► 359** |  7.

 *For secure radial location, tight fits are necessary*

Radial location of bearings – fit recommendations





In addition to supporting the rings adequately, the bearings must also be securely located in a radial direction, to prevent creep of the bearing rings on the mating parts under load. This is generally achieved by means of tight fits between the bearing rings and the mating parts. If the rings are not secured adequately or correctly, this can cause severe damage to the bearings and adjacent machine parts. Influencing factors, such as the conditions of rotation, magnitude of the load, internal clearance, temperature conditions, design of the mating parts and the mounting and dismounting options must be taken into consideration in the selection of fits.





If shock type loads occur, tight fits (transition fit or interference fit) are required to prevent the rings from coming loose at any point. Clearance, transition or interference fits **► 150** |  6 and **► 158** |  7.



The following information provided in Technical principles must be taken into consideration in the design of bearing arrangements:

- conditions of rotation **► 145**
- tolerance classes for cylindrical shaft seats (radial bearings) **► 147** |  2
- shaft fits **► 150** |  6
- tolerance classes for bearing seats in housings (radial bearings) **► 148** |  4
- housing fits **► 158** |  7.

 *Location of the outer ring by means of retaining slots*

For location of the bearings in the housing by means of retaining slots and locking pin **► 351** |  3.



 *The bearings must also be securely located in an axial direction*

Axial location of bearings – location methods

As a tight fit alone is not normally sufficient to also locate the bearing rings securely on the shaft and in the housing bore in an axial direction, this must usually be achieved by means of an additional axial location or retention method. The axial location of the bearing rings must be matched to the type of bearing arrangement. Shaft and housing shoulders, housing covers, nuts, spacer rings and retaining rings etc., are fundamentally suitable **► 351** |  3.

 *A minimum of IT6 should be provided for the shaft seat and a minimum of IT7 for the housing seat*

Dimensional, geometrical and running accuracy of the bearing seats

The accuracy of the bearing seat on the shaft and in the housing should correspond to the accuracy of the bearing used. For four point contact bearings with the tolerance class Normal, the shaft seat should correspond to a minimum of standard tolerance grade IT6 and the housing seat to a minimum of IT7. Guide values for the geometrical and positional tolerances of bearing seating surfaces **► 359** |  5, tolerances t_1 to t_3 in accordance with **► 168** |  11. Numerical values for IT grades **► 359** |  6.

5
Guide values
for the geometrical and
positional tolerances
of bearing seating surfaces

Bearing tolerance class		Bearing seating surface	Standard tolerance grades to ISO 286-1 (IT grades)			
to ISO 492	to DIN 620		Diameter tolerance	Roundness tolerance	Parallelism tolerance	Total axial runout tolerance of abutment shoulder
				t ₁	t ₂	t ₃
Normal	PN (P0)	Shaft	IT6 (IT5)	Circumferential load IT4/2	Circumferential load IT4/2	IT4
				Point load IT5/2	Point load IT5/2	
		Housing	IT7 (IT6)	Circumferential load IT5/2	Circumferential load IT5/2	IT5
				Point load IT6/2	Point load IT6/2	

6
Numerical values
for ISO standard tolerances
(IT grades) to ISO 286-1:2010

IT grade	Nominal dimension in mm								
	over	10	18	30	50	80	120	180	250
	incl.	18	30	50	80	120	180	250	315
	Values in µm								
IT4	5	6	7	8	10	12	14	16	
IT5	8	9	11	13	15	18	20	23	
IT6	11	13	16	19	22	25	29	32	
IT7	18	21	25	30	35	40	46	52	

Roughness of cylindrical bearing seating surfaces

Ra must not be too high

The roughness of the bearing seats must be matched to the tolerance class of the bearings. The mean roughness value Ra must not be too high, in order to maintain the interference loss within limits. The shafts must be ground, while the bores must be precision turned. Guide values as a function of the IT grade of bearing seating surfaces ▶ 359 | 7.

7
Roughness values
for cylindrical bearing seating
surfaces – guide values

Nominal diameter of the bearing seat d (D) mm		Recommended mean roughness value for ground bearing seats Ramax µm			
		Diameter tolerance (IT grade)			
over	incl.	IT7	IT6	IT5	IT4
–	80	1,6	0,8	0,4	0,2
80	500	1,6	1,6	0,8	0,4

Mounting dimensions for the contact surfaces of bearing rings

The contact surfaces for the rings must be of sufficient height

The mounting dimensions of the shaft and housing shoulders, and spacer rings etc., must ensure that the contact surfaces for the bearing rings are of sufficient height. However, they must also reliably prevent rotating parts of the bearing from grazing stationary parts. Proven mounting dimensions for the radii and diameters of the abutment shoulders ▶ 362 | 7. These dimensions are limiting dimensions (maximum or minimum dimensions); the actual values should not be higher or lower than specified.

1.17 Mounting and dismounting



The mounting and dismounting options for four point contact bearings, by thermal, hydraulic or mechanical methods, must be taken into consideration in the design of the bearing position.

As the bearings are not self-retaining, they are easy to mount

Four point contact bearings are not self-retaining. As a result, the outer ring with the ball and cage assembly can be mounted separately from the two inner ring halves ▶ 350 | 1.1. This gives simplified mounting of the bearings.

Rolling bearings must be handled with great care

Schaeffler Mounting Handbook

Rolling bearings are well-proven precision machine elements for the design of economical and reliable bearing arrangements, which offer high operational security. In order that these products can function correctly and achieve the envisaged operating life without detrimental effect, they must be handled with care.



The Schaeffler Mounting Handbook MH 1 gives comprehensive information about the correct storage, mounting, dismounting and maintenance of rotary rolling bearings ▶ <https://www.schaeffler.de/std/1D53>. It also provides information which should be observed by the designer, in relation to the mounting, dismounting and maintenance of bearings, in the original design of the bearing position. This book is available from Schaeffler on request.

1.18 Legal notice regarding data freshness

The further development of products may also result in technical changes to catalogue products

Of central interest to Schaeffler is the further development and optimisation of its products and the satisfaction of its customers. In order that you, as the customer, can keep yourself optimally informed about the progress that is being made here and with regard to the current technical status of the products, we publish any product changes which differ from the printed version in our electronic product catalogue.



We therefore reserve the right to make changes to the data and illustrations in this catalogue. This catalogue reflects the status at the time of printing. More recent publications released by us (as printed or digital media) will automatically precede this catalogue if they involve the same subject. Therefore, please always use our electronic product catalogue to check whether more up-to-date information or modification notices exist for your desired product.

Link to electronic product catalogue



The following link will take you to the Schaeffler electronic product catalogue: ▶ <https://medias.schaeffler.com>.

1.19 Further information

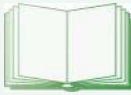

In addition to the data in this chapter, the following chapters in Technical principles must also be observed in the design of bearing arrangements:

- Determining the bearing size ▶ 34
- Rigidity ▶ 54
- Friction and increases in temperature ▶ 56
- Speeds ▶ 64
- Bearing data ▶ 97
- Lubrication ▶ 70
- Sealing ▶ 182
- Design of bearing arrangements ▶ 139
- Mounting and dismounting ▶ 191.





Four point contact bearings

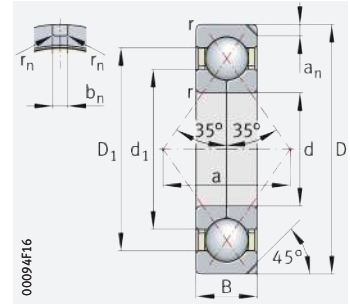
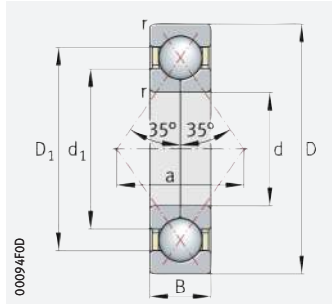

N2 variant

d = 17 – 85 mm

Main dimensions			Basic load ratings		Fatigue limit load	Limiting speed	Speed rating	Mass	Designation ▶ 356 1.12 ▶ 356 1.13 X-life ▶ 351
d	D	B	dyn. C _r	stat. C _{0r}	C _{ur}	n _G	n _{Dr}	m	
			N	N	N	min ⁻¹	min ⁻¹	≈ kg	
17	47	14	24 500	15 100	1 100	29 500	12 000	0,148	QJ303-XL-MPA
20	52	15	31 000	19 600	1 320	26 000	10 700	0,184	QJ304-XL-MPA
25	52	15	26 000	18 800	1 260	25 500	12 300	0,171	QJ205-XL-MPA
	62	17	46 500	31 500	2 120	14 100	8 800	0,256	QJ305-XL-TVP
30	62	16	37 500	27 500	1 880	21 100	10 200	0,254	QJ206-XL-MPA
	72	19	61 000	43 000	2 900	11 900	7 600	0,379	QJ306-XL-TVP
35	72	17	45 000	35 500	2 400	18 000	8 500	0,359	QJ207-XL-MPA
	80	21	65 000	51 000	3 400	10 800	7 000	0,516	QJ307-XL-TVP
40	80	18	58 000	46 500	3 150	10 600	7 500	0,399	QJ208-XL-TVP
	90	23	90 000	69 000	4 650	9 300	6 200	0,695	QJ308-XL-TVP
45	85	19	66 000	57 000	3 850	9 800	6 900	0,467	QJ209-XL-TVP
	100	25	107 000	83 000	6 100	8 300	5 700	0,934	QJ309-XL-TVP
50	90	20	62 000	56 000	3 850	13 900	6 700	0,609	QJ210-XL-MPA
	110	27	115 000	92 000	6 600	11 300	5 400	1,39	QJ310-XL-MPA
55	100	21	81 000	76 000	5 200	8 200	5 800	0,697	QJ211-XL-TVP
	120	29	133 000	108 000	7 900	10 300	5 000	1,76	QJ311-XL-MPA
60	95	18	47 500	52 000	2 600	13 100	5 800	0,42	QJ1012-MPA
	110	22	98 000	93 000	6 400	7 400	5 300	0,889	QJ212-XL-TVP
	130	31	152 000	126 000	8 900	9 500	4 700	2,2	QJ312-XL-MPA
65	120	23	106 000	104 000	7 000	10 300	4 900	1,27	QJ213-XL-MPA
	140	33	171 000	145 000	10 500	8 700	4 450	2,71	QJ313-XL-MPA
70	125	24	123 000	122 000	9 100	6 500	4 600	1,19	QJ214-XL-TVP
	150	35	198 000	165 000	11 500	8 100	4 200	3,29	QJ314-XL-MPA
75	130	25	129 000	130 000	9 100	6 200	4 450	1,34	QJ215-XL-TVP
	160	37	229 000	204 000	14 000	7 600	3 900	3,95	QJ315-XL-N2-MPA
80	140	26	136 000	137 000	9 400	8 600	4 250	1,84	QJ216-XL-MPA
	170	39	226 000	220 000	10 800	7 000	3 750	4,65	QJ316-N2-MPA
85	130	22	80 000	95 000	4 650	9 200	4 250	1,11	QJ1017-N2-MPA
	150	28	158 000	160 000	10 800	8 000	4 050	2,3	QJ217-XL-MPA
	180	41	248 000	255 000	12 400	6 600	3 550	5,53	QJ317-N2-MPA

medias ▶ <https://www.schaeffler.de/std/1D9E>

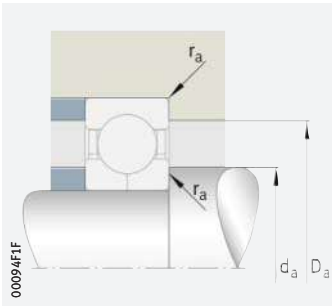

Mounting dimensions



Dimensions								Mounting dimensions		
d	r	D ₁	d ₁	a	a _n	b _n	r _n	d _a	D _a	r _a
	min.	≈	≈	≈				min.	max.	max.
17	1	36,4	27,8	22	–	–	–	22,6	41,4	1
20	1,1	41,4	30,6	26	–	–	–	27	45	1
25	1	43,1	33,9	27	–	–	–	31	46	1
	1,1	49,5	37,5	31	–	–	–	32	55	1
30	1	50,7	40,4	32	–	–	–	36	56	1
	1,1	58	44	36	–	–	–	37	65	1
35	1,1	59,1	48	38	–	–	–	42	65	1
	1,5	64,8	50,8	41	–	–	–	44	71	1,5
40	1,1	66,8	53,7	42	–	–	–	47	73	1
	1,5	73,4	56,7	46	–	–	–	49	81	1,5
45	1,1	72	58,5	45	–	–	–	52	78	1
	1,5	81,7	63,4	51	–	–	–	54	91	1,5
50	1,1	76,4	63,7	49	–	–	–	57	83	1
	2	89,6	70,5	56	–	–	–	61	99	2
55	1,5	84,7	70,4	54	–	–	–	64	91	1,5
	2	97,8	77,2	61	–	–	–	66	109	2
60	1,1	83,1	72,4	54	–	–	–	66	89	1
	1,5	93	77,1	60	–	–	–	69	101	1,5
	2,1	106,9	84,2	67	–	–	–	72	118	2,1
65	1,5	101,5	84,2	65	–	–	–	74	111	1,5
	2,1	114,4	91	72	–	–	–	77	128	2,1
70	1,5	106,3	89,1	68	–	–	–	79	116	1,5
	2,1	123,6	97,7	77	–	–	–	82	138	2,1
75	1,5	111,5	93,9	72	–	–	–	84	121	1,5
	2,1	131	104,4	82	10,1	8,5	2	87	148	2,1
80	2	119,6	100,9	77	–	–	–	91	129	2
	2,1	140,8	110,7	88	10,1	8,5	2	92	158	2,1
85	1,1	114,8	101,1	75	5	6,5	0,5	91	124	1
	2	128,6	107,6	82	–	–	–	96	139	2
	3	148,7	117,9	93	11,7	10,5	2	99	166	2,5



Four point contact bearings

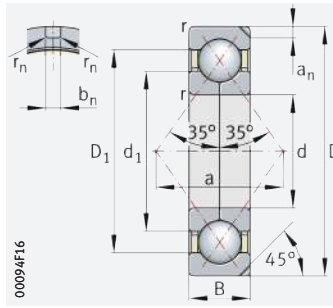

N2 variant

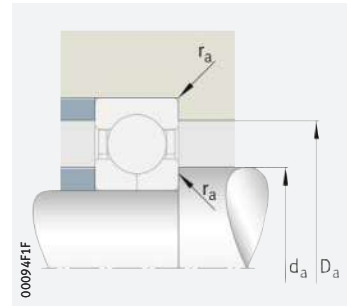

Mounting dimensions

d = 90 – 200 mm

Main dimensions			Basic load ratings		Fatigue limit load	Limiting speed	Speed rating	Mass	Designation ▶ 356 1.12 ▶ 356 1.13 X-life ▶ 351
d	D	B	dyn. Cr	stat. Cor	C _{ur}	n _G	n _{0r}	m	
			N	N	N	min ⁻¹	min ⁻¹	≈ kg	
90	160	30	189 000	198 000	12 500	4 950	3 750	2,35	QJ218-XL-N2-TVP
	190	43	265 000	285 000	12 900	6 300	3 350	6,31	QJ318-N2-MPA
95	145	24	98 000	121 000	5 600	8 200	3 850	1,56	QJ1019-N2-MPA
	170	32	190 000	212 000	10 100	7 000	3 700	3,41	QJ219-N2-MPA
	200	45	285 000	315 000	14 100	5 900	3 250	7,45	QJ319-N2-MPA
100	180	34	224 000	241 000	11 200	6 600	3 550	4,02	QJ220-N2-MPA
	215	47	325 000	365 000	16 300	5 400	3 000	9,04	QJ320-N2-MPA
105	160	26	117 000	145 000	6 400	7 400	3 550	2,035	QJ1021-N2-MPA
	190	36	233 000	255 000	11 600	6 200	3 450	4,81	QJ221-N2-MPA
110	170	28	138 000	184 000	7 900	6 900	3 350	2,524	QJ1022-N2-MPA
	200	38	249 000	285 000	12 300	5 900	3 350	5,66	QJ222-N2-MPA
	240	50	345 000	415 000	17 400	4 950	2 700	12,2	QJ322-N2-MPA
120	180	28	145 000	200 000	8 300	6 500	3 100	2,707	QJ1024-N2-MPA
	215	40	285 000	340 000	14 700	5 400	3 050	6,74	QJ224-N2-MPA
	260	55	385 000	485 000	19 300	4 550	2 480	15,6	QJ324-N2-MPA
130	230	40	295 000	370 000	15 400	5 100	2 800	7,66	QJ226-N2-MPA
	280	58	425 000	570 000	21 600	4 200	2 220	19,2	QJ326-N2-MPA
140	250	42	315 000	420 000	16 500	4 700	2 600	9,69	QJ228-N2-MPA
	300	62	470 000	660 000	24 900	3 900	2 030	23,2	QJ328-N2-MPA
150	225	35	205 000	295 000	10 900	5 100	2 650	6,167	QJ1030-N2-MPA
	270	45	350 000	485 000	18 400	4 350	2 360	12,2	QJ230-N2-MPA
	320	65	510 000	730 000	25 500	3 650	1 870	28	QJ330-N2-MPA
160	240	38	231 000	335 000	11 900	4 750	2 600	6,35	QJ1032-N2-MPA
	290	48	370 000	530 000	19 900	4 050	2 200	15,3	QJ232-N2-MPA
170	260	42	280 000	430 000	14 800	4 350	2 340	8,788	QJ1034-N2-MPA
	310	52	420 000	630 000	22 800	3 750	2 010	18,6	QJ234-N2-MPA
180	280	46	340 000	510 000	18 700	4 050	2 140	11,42	QJ1036-N2-MPA
	320	52	435 000	680 000	23 900	3 600	1 870	19,6	QJ236-N2-MPA
190	290	46	345 000	540 000	19 200	3 900	2 010	11,4	QJ1038-N2-MPA
200	310	51	390 000	620 000	21 300	3 600	1 890	15	QJ1040-N2-MPA

medias ▶ <https://www.schaeffler.de/std/1D9F>



Dimensions								Mounting dimensions		
d	r	D ₁	d ₁	a	a _n	b _n	r _n	d _a	D _a	r _a
	min.	≈	≈	≈				min.	max.	max.
90	2	136,1	114,3	88	8,1	6,5	1	101	149	2
	3	157,1	124,5	98	11,7	10,5	2	104	176	2,5
95	1,5	128,1	112,9	84	5	6,5	0,5	102	138	1,5
	2,1	144,4	121	93	8,1	6,5	1	107	158	2,1
	3	165,4	131,2	103	11,7	10,5	2	109	186	2,5
100	2,1	153,6	127,7	98	10,1	8,5	2	112	168	2,1
	3	176,6	139	110	11,7	10,5	2	114	201	2,5
105	2	141,5	124,6	93	6,5	6,5	0,5	114	151	2
	2,1	161,6	134,8	103	10,1	8,5	2	117	178	2,1
110	2	149,8	131,3	98	6,5	6,5	0,5	119	161	2
	2,1	169,8	141,7	109	10,1	8,5	2	122	188	2,1
	3	195,5	156,5	123	11,7	10,5	2	124	226	2,5
120	2	159,2	141,3	105	6,5	6,5	0,5	129	171	2
	2,1	183,7	152,8	117	11,7	10,5	2	132	203	2,1
	3	210,6	169,9	133	11,7	10,5	2	134	246	2,5
130	3	196,2	165,4	127	11,7	10,5	2	144	216	2,5
	4	228	184,1	144	12,7	10,5	2	147	263	3
140	3	210,5	180	137	11,7	10,5	2	154	236	2,5
	4	243	197,5	154	12,7	10,5	2	157	283	3
150	2,1	199,4	176,8	131	8,1	6,5	1	160,2	214,8	2,1
	3	226,7	193,8	147	11,7	10,5	2	164	256	2,5
	4	261	211,2	165	12,7	10,5	2	167	303	3
160	2,1	212,8	188,5	140	10,1	8,5	2	170	230	2,1
	3	240	208,1	158	12,7	10,5	2	174	276	2,5
170	2,1	229,5	201,9	151	11,7	10,5	2	180,2	249,8	2,1
	4	260,5	221,5	168	12,7	10,5	2	187	293	3
180	2,1	245	215,5	161	11,7	10,5	2	190,2	269,8	2,1
	4	269	231	175	12,7	10,5	2	197	303	3
190	2,1	256,2	225,3	168	11,7	10,5	2	200,2	279,8	2,1
200	2,1	271,5	238,9	179	12,7	10,5	2	210,2	299,8	2,1

Self-aligning ball bearings



Matrix for bearing preselection _____ 369

1 Self-aligning ball bearings _____ **370**

1.1	Bearing design _____	370
1.2	Load carrying capacity _____	372
1.3	Compensation of angular misalignments _____	372
1.4	Lubrication _____	373
1.5	Sealing _____	373
1.6	Speeds _____	374



1.7	Noise	374	1.17	Mounting and dismounting	383
1.8	Temperature range	374	1.18	Legal notice regarding data freshness	384
1.9	Cages	375	1.19	Further information	384
1.10	Internal clearance	375	Product tables	386	
1.11	Dimensions, tolerances	376		<i>Self-aligning ball bearings with cylindrical or tapered bore</i>	386
1.12	Suffixes	377		<i>Self-aligning ball bearings with extended inner ring</i>	400
1.13	Structure of bearing designation	377		<i>Self-aligning ball bearings with adapter sleeve</i>	402
1.14	Dimensioning	378			
1.15	Minimum load	378			
1.16	Design of bearing arrangements	379			





Matrix for bearing preselection

The matrix gives an overview of the types and design features of self-aligning ball bearings.

It can be used to make a preliminary assessment of whether a bearing is fundamentally suitable for the envisaged application.

The additional information provided in the product chapter (see column "detailed information") and in the Technical principles must, however, be observed in addition to this overview in selection of the bearing.

Design features and suitability			Self-aligning ball bearings			
			cylindrical or tapered bore	with extended inner ring	with adapter sleeve	detailed information
+++ extremely suitable ++ highly suitable + suitable (+) suitable with restrictions – not suitable/not applicable ✓ available						370
Load carrying capacity	radial		++	++	++	372 1.2
	axial, one direction		(+)	(+)	(+)	372 1.2
	axial, both directions		(+)	(+)	(+)	372 1.2
	moments		–	–	–	
Compensation of angular misalignments	static		+++	+++	+++	372 1.3
	dynamic		+++	+++	+++	372 1.3
Bearing design	cylindrical bore		✓	✓	✓	370 1.1
	tapered bore		✓	–	–	370 1.1
	separable		–	–	–	383 1.17
Lubrication	greased		✓ ¹⁾	–	✓ ¹⁾	373 1.4
Sealing	open		✓	✓	✓	373 1.5
	non-contact		–	–	–	
	contact		✓	–	✓	373 1.5
Operating temperature in °C	from to		–30 +150 ²⁾	–30 +150	–30 +150 ²⁾	374 1.8
Suitability for	high speeds		+	+	+	374 1.6
	high running accuracy		–	–	–	376 1.11 114
	low-noise running		(+)	(+)	(+)	374 1.7 27
	high rigidity		(+)	(+)	(+)	54
	reduced friction		++	++	++	56
	length compensation within bearing		–	–	–	
	non-locating bearing arrangement		+	+	+	139
	locating bearing arrangement		+	+	+	139
X-life design			–	–	–	
Bearing bore ³⁾ d in mm	from to		5 150	20 60	17 100	386
Product tables	from page		386	400	402	

- 1) Sealed bearings only
- 2) Valid for open bearings with brass cage
- 3) For bearings with adapter sleeve: inside diameter of adapter sleeve



1 Self-aligning ball bearings



- Self-aligning ball bearings are particularly suitable:
- if there is skewing between the outer and inner ring (for the compensation of angular misalignments) ▶ 372 | 1.3
 - for bearing arrangements with high radial loads ▶ 372 | 1.2
 - for higher speeds on account of their point contact, than barrel roller bearings with line contact
 - where bearings with the above-mentioned characteristics are expected to run more quietly and at lower temperatures, even at high speeds.

For an overview of other product-specific features, see the Matrix for bearing preselection ▶ 369.

1
Self-aligning ball bearing:
speed comparison with barrel
roller bearing, compensation
of misalignments

n_G = limiting speed

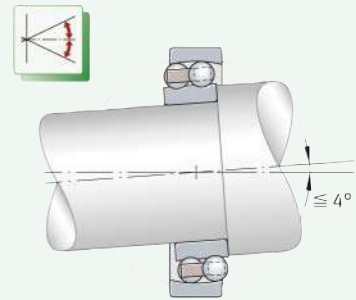
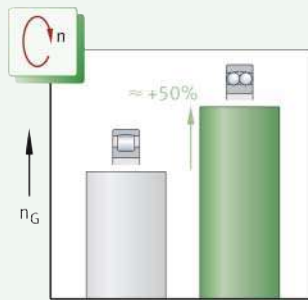

1.1 Bearing design

Design variants

- Self-aligning ball bearings are available as:
- bearings of basic design ▶ 371 | 2
 - bearings with extended inner ring and locating slot ▶ 371 | 3
 - bearings with adapter sleeve ▶ 371 | 4
 - bearings with ball projection ▶ 372 | 5.

The outer ring has a curved raceway

Bearings of basic design

Self-aligning ball bearings are double row, self-retaining radial ball bearings, which are part of the group of self-aligning bearings. The outer ring has a single concave raceway for the two rows of balls. As a result, the bearings permit the compensation of static and dynamic angular misalignments (skewing between the inner and outer ring) within certain limits ▶ 372 | 1.3. The inner ring has two formed raceway grooves in which the rolling elements run. Solid cages made from polyamide PA66 or brass are used ▶ 375 | 2.

The bore is cylindrical or tapered

Bearings of basic design are supplied with a cylindrical bore; self-aligning ball bearings of series 12, 13, 22 and 23 are also available with a tapered bore ▶ 371 | 2.



Bearings with a tapered bore have a bore taper of 1:12 and the suffix K ▶ 377 | 5.

2
Self-aligning ball bearings
of basic design

F_r = radial load
 F_a = axial load

- ① Self-aligning ball bearing with cylindrical bore, open
- ② Self-aligning ball bearing with tapered bore, open, bore taper 1:12

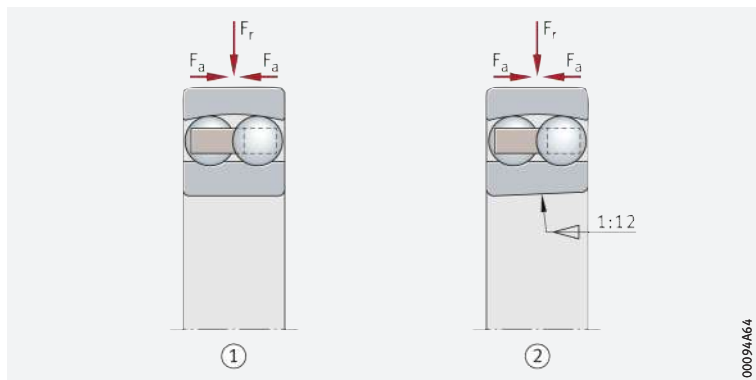

00094A64

Suitable for simple bearing arrangements

Bearings with extended inner ring and locating slot

Self-aligning ball bearings of series 112 have an extended inner ring with cylindrical bore on both sides and a slot on one side of the inner ring **▶ 371** | **3**. These bearings are particularly suitable for simple bearing arrangements with conventional shafts. Due to the bearing bore tolerance J7, mounting and dismounting of this type is very simple. The slot is used to locate the bearings in an axial direction by means of a grub screw; **▶ 380** | **8**.



3
Self-aligning ball bearing
with extended inner ring and
locating slot

F_r = radial load
 F_a = axial load

- ① Locating slot

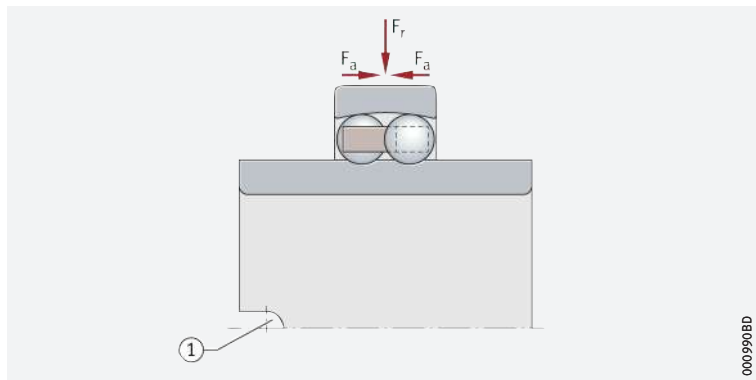

000950BD

Ready-to-fit bearing mounting kits facilitate the ordering and mounting of self-aligning ball bearings

Bearings with adapter sleeve

Complete bearing mounting kits are also available for use in locating self-aligning ball bearings with a tapered bore on a cylindrical shaft journal. These units comprise the bearing, slotted adapter sleeve, tab washer and locknut (series 12..-K + H, 13..-K + H, 22..-K + H, 23..-K + H, 22..-K-2RS + H) **▶ 371** | **4**. Adapter sleeves allow bearings to be located on smooth and stepped shafts. The adapter sleeves must also be stated when placing the order. Ordering example **▶ 377** | **7**.

4
Self-aligning ball bearings
with adapter sleeve

F_r = radial load
 F_a = axial load

- ① Self-aligning ball bearing, open
- ② Self-aligning ball bearing, lip seal on both sides
- ③ Adapter sleeve
- ④ Locknut
- ⑤ Tab washer

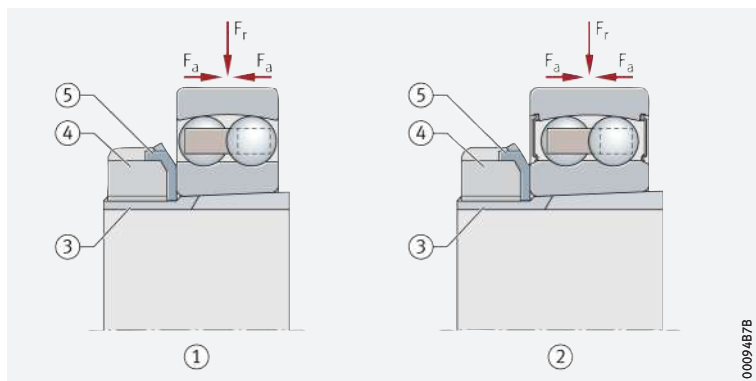

00094B78

☞ *The dimension C_1 must be observed*



Bearings with ball projection

In some self-aligning ball bearings with a brass cage (bearings with the suffix M), the balls project to a certain extent at the sides ▶ 372 | 5.

The projection is marked C_1 in the product tables. This must be taken into consideration when defining the dimensions for the adjacent parts.



Self-aligning ball bearing with ball projection

C_1 = ball projection

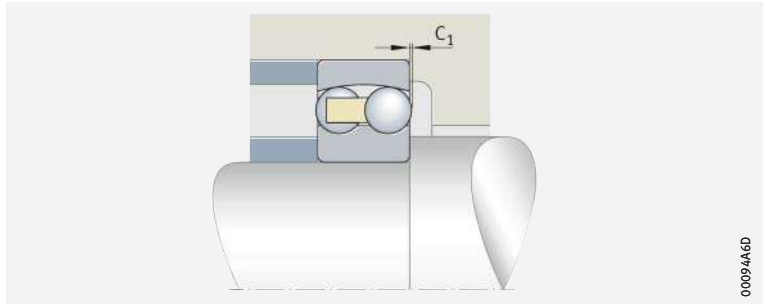

0009446D

1.2 Load carrying capacity

☞ *Suitable for high radial and low axial loads*

In addition to high radial forces, self-aligning ball bearings also support low axial forces from both directions ▶ 371 | 2 to ▶ 371 | 4. Due to the point contact with which the rolling elements are in contact with the raceways, the radial load carrying capacity of the bearings is lower than for barrel roller bearings with line contact.

Axial load carrying capacity of bearings with adapter sleeve



Where bearings with adapter sleeves are located on a smooth shaft without a fixed stop (e.g. rigid shoulder), their axial load carrying capacity is dependent on the friction between the shaft and the sleeve.



If there is any doubt about the axial load carrying capacity of the location method, please consult Schaeffler.

1.3 Compensation of angular misalignments

☞ *Self-aligning ball bearings compensate dynamic and static angular misalignments*

Due to the concave rolling element raceway in the outer ring, self-aligning ball bearings are capable of angular adjustment. As a result, they permit skewing between the outer and inner ring within certain limits, without causing damage to the bearings, and can thus compensate misalignments, shaft deflections and housing deformations.

Permissible adjustment angle

☞ *With a rotating inner ring, self-aligning ball bearings can swivel up to 4° from their central position*

Under normal operating conditions and with a rotating inner ring, self-aligning ball bearings can swivel up to 4° from their central position, whereas sealed bearings can swivel up to 1,5°. The extent to which these values can be used in practice is, however, essentially dependent on the design of the bearing arrangement.



If the outer ring rotates or the inner ring undergoes tumbling motion, the angular adjustment facility is considerably smaller. In such cases, please consult Schaeffler.

1.4 Lubrication

☞ Greased bearings are maintenance-free

Sealed self-aligning ball bearings are lubricated with a high quality lithium soap grease with a mineral oil base, which has good anti-corrosion characteristics. The grease filling is measured so that it is sufficient for the entire life of the bearing. As a result, these bearings are maintenance-free.



Do not wash greased bearings out prior to mounting. If mounting is carried out using thermal tools, the bearings should not be heated to a temperature in excess of +80 °C, taking account of the grease filling and seal material. If higher heating temperatures are required, it must be ensured that the permissible upper temperature limits for grease and seals are not exceeded. Schaeffler recommends the use of induction heating devices for heating purposes ► 231.

☞ Lubrication for ungreased bearings

Open bearings are not greased. They can be lubricated from the end faces using oil or grease.

☞ Compatibility with plastic cages

When using bearings with plastic cages, compatibility between the lubricant and the cage material must be ensured if synthetic oils, lubricating greases with a synthetic oil base or lubricants containing a high proportion of EP additives are used.

☞ Observe oil change intervals

Aged oil and additives in the oil can impair the operating life of plastics at high temperatures. As a result, stipulated oil change intervals must be strictly observed.



1.5 Sealing

☞ Also available with lip seals

Self-aligning ball bearings of series 22 and 23 are also available with contact seals on both sides of the bearing ► 371 | ☐ 4. The integration of such seals into the bearing provides a compact, economical and reliable solution for the sealing of bearing arrangements. In order that the highest possible sealing effect can still be achieved with minimum friction, the seal lips are in contact with the ground opposing running surface of the inner ring under light pressure. The sealing material used is the proven, oil-resistant and wear-resistant elastomer material NBR. Sealed self-aligning ball bearings have the suffix 2RS ► 377 | ☐ 5.

☞ Sealing can be achieved in the adjacent construction, if the bearings are open

In the case of unsealed bearings, sealing of the bearing position must be carried out in the adjacent construction. The sealing system should reliably prevent:

- moisture and contaminants from entering the bearing
- the egress of lubricant from the bearing.

1.6 Speeds

Speeds in the product tables

The product tables give two speeds for most bearings 386 | 5:

- the kinematic limiting speed n_G
- the thermal speed rating $n_{\vartheta r}$.

Limiting speeds



The limiting speed n_G is the kinematically permissible speed of the bearing. Even under favourable mounting and operating conditions, this value should not be exceeded without prior consultation with Schaeffler 64.

The values given in the product tables are valid for oil lubrication in the case of bearings without seals and for grease lubrication where bearings are supplied greased and with seals.

Values for grease lubrication

For grease lubrication, 85% of the value stated in the product tables is permissible in each case.

Reference speeds

$n_{\vartheta r}$ is used to calculate n_{ϑ}

The thermal speed rating $n_{\vartheta r}$ is not an application-oriented speed limit, but is a calculated ancillary value for determining the thermally safe operating speed n_{ϑ} 64.

Bearings with contact seals

For bearings with contact seals, no reference speeds are defined in accordance with DIN ISO 15312:2004. As a result, only the limiting speed n_G is given in the product tables for these bearings.

1.7 Noise

Schaeffler Noise Index

The Schaeffler Noise Index (SGI) is not yet available for this bearing type 69. The data for these bearing series will be introduced and updated in stages.

Further information:

- **medias** <https://medias.schaeffler.com>.

1.8 Temperature range

Limiting values

The operating temperature of the bearings is limited by:

- the dimensional stability of the bearing rings and rolling elements
- the cage
- the lubricant
- the seals.

Possible operating temperatures of self-aligning ball bearings 675 | 5.

1
Permissible temperature ranges

Operating temperature	Open self-aligning ball bearings		Sealed self-aligning ball bearings
	with brass cage	with polyamide cage PA66	
	-30 °C to +150 °C	-30 °C to +120 °C	-30 °C to +100 °C, limited by the lubricant and seal material



In the event of anticipated temperatures which lie outside the stated values, please contact Schaeffler.

1.9 Cages

☞ *Solid cages made from brass and polyamide PA66 are used as standard*

Standard cages and additional cage designs for self-aligning ball bearings ▶ 375 | 2. Other cage designs are available by agreement. With such cages, however, suitability for high speeds and temperatures as well as the basic load ratings may differ from the values for the bearings with standard cages.



For high continuous temperatures and applications with difficult operating conditions, bearings with brass or sheet steel cages should be used. If there is any uncertainty regarding cage suitability, please consult Schaeffler.



Cage, cage suffix, bore code

Bearing series	Solid cage made from polyamide PA66 TVH standard Bore code	Solid brass cage	
		M	
		standard	also available for
10	8	–	–
12	up to 18	from 19	–
13	up to 13	from 14	03
22	up to 16, 18	17, from 19	12, 14
23	up to 13	from 14	05 to 10, 12, 13
112	04 to 12	–	–



1.10 Internal clearance

☞ *The standard is CN*

Radial internal clearance – bearings with cylindrical bore

Self-aligning ball bearings with cylindrical bore are manufactured as standard with radial internal clearance CN (normal) ▶ 375 | 3. CN is not stated in the designation.



Certain sizes are also available by agreement with the larger internal clearance C3.



The values for radial internal clearance correspond to DIN 620-4:2004 (ISO 5753-1:2009) ▶ 375 | 3. They are valid for bearings which are free from load and measurement forces (without elastic deformation).



Radial internal clearance of self-aligning ball bearings with cylindrical bore

Nominal bore diameter d		Radial internal clearance			
		CN (Group N)		C3 (Group 3)	
mm		μm		μm	
over	incl.	min.	max.	min.	max.
–	6	5	15	10	20
6	10	6	17	12	25
10	14	6	19	13	26
14	18	8	21	15	28
18	24	10	23	17	30
24	30	11	24	19	35
30	40	13	29	23	40
40	50	14	31	25	44
50	65	16	36	30	50
65	80	18	40	35	60
80	100	22	48	42	70
100	120	25	56	50	83
120	140	30	68	60	100
140	160	35	80	70	120

The standard is C3

Radial internal clearance – bearings with tapered bore

Self-aligning ball bearings with tapered bore are manufactured as standard with the larger radial internal clearance C3 376 | 4.



Certain sizes are also available by agreement with internal clearance CN (normal).



The values for radial internal clearance correspond to DIN 620-4:2004 (ISO 5753-1:2009) 376 | 4. They are valid for bearings which are free from load and measurement forces (without elastic deformation).

4
Radial internal clearance
of self-aligning ball bearings
with tapered bore

Nominal bore diameter		Radial internal clearance			
d		CN (Group N)		C3 (Group 3)	
mm		μm		μm	
over	incl.	min.	max.	min.	max.
18	24	13	26	20	33
24	30	15	28	23	39
30	40	19	35	29	46
40	50	22	39	33	52
50	65	27	47	41	61
65	80	35	57	50	75
80	100	42	68	62	90
100	120	50	81	75	108
120	140	60	98	90	130
140	160	65	110	100	150

1.11

Dimensions, tolerances

Dimension standards



The main dimensions of self-aligning ball bearings correspond to DIN 630:2011, with the exception of bearing series 112. Nominal dimensions of self-aligning ball bearings 386 | .

Series 112

The dimensions of self-aligning ball bearings with extended inner ring (bearing series 112) correspond to DIN 630-2, which was withdrawn in 1993. Nominal dimensions of bearings 400 | .

Chamfer dimensions



The limiting dimensions for chamfer dimensions correspond to DIN 620-6:2004. Overview and limiting values 135 | 7.11. Nominal value of chamfer dimension 386 | .

Tolerances



The tolerances for the dimensional and running accuracy of self-aligning ball bearings correspond to tolerance class Normal in accordance with ISO 492:2014, except for the bearing bore of bearing series 112, which is manufactured to tolerance class J7. Tolerance values in accordance with ISO 492 122 | 8.

1.12 Suffixes

5
Suffixes and corresponding descriptions

For a description of the suffixes used in this chapter ▶ 377 | **5** and **medias** interchange ▶ <https://www.schaeffler.de/std/1D52>.

Suffix	Description of suffix	
C3	Radial internal clearance C3 (larger than normal)	Standard for bearings with tapered bore
CN	Radial internal clearance CN (normal)	Special design for bearings with tapered bore, available by agreement
K	Tapered bore	Standard
M	Solid brass cage	Standard, cage material dependent on bearing series and bore code
TVH	Solid cage made from glass fibre reinforced polyamide PA66	Standard, cage material dependent on bearing series and bore code
2RS	Contact seal on both sides	Dependent on bearing series

1.13 Structure of bearing designation



6
Examples of composition of bearing designation

The designation of bearings follows a set model. Examples ▶ 377 | **6** and ▶ 377 | **7**. The composition of designations is subject to DIN 623-1 ▶ 102 | **10**.

6
Self-aligning ball bearing with tapered bore: designation structure

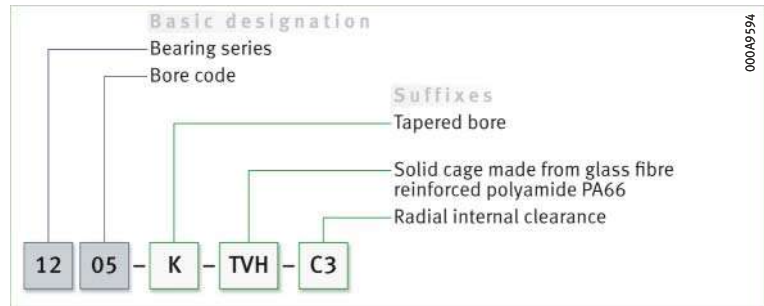

7
Self-aligning ball bearing with tapered bore and adapter sleeve: designation structure

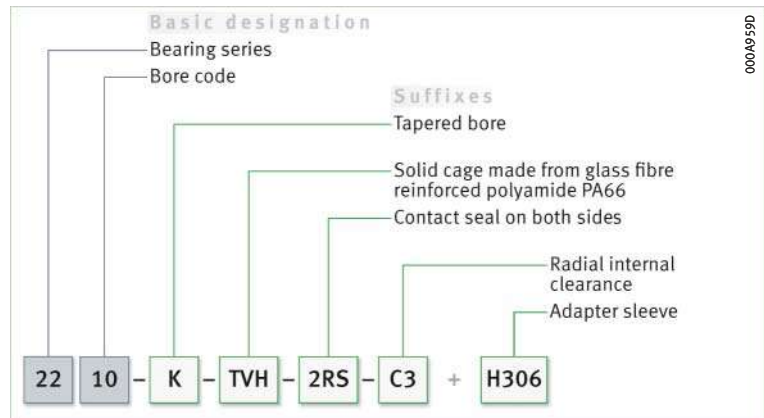

1.14 Dimensioning

$P = F_r$ under purely radial load of constant magnitude and direction

P is a substitute force for combined load and various load cases

$F_a/F_r \leq e$ or $F_a/F_r > e$

Equivalent dynamic bearing load

The basic rating life equation $L = (C_r/P)^P$ used in the dimensioning of bearings under dynamic load assumes a load of constant magnitude and direction. In radial bearings, this is a purely radial load F_r . If this condition is met, the bearing load F_r is used in the rating life equation for P ($P = F_r$). If this condition is not met, a constant radial force must first be determined for the rating life calculation that (in relation to the rating life) represents an equivalent load. This force is known as the equivalent dynamic bearing load P .

The calculation of P is dependent on the load ratio F_a/F_r and the calculation factor e ▶ 378 | f1 1 and ▶ 378 | f1 2.

f1
Equivalent dynamic load

$$\frac{F_a}{F_r} \leq e \Rightarrow P = F_r + Y_1 \cdot F_a$$

f2
Equivalent dynamic load

$$\frac{F_a}{F_r} > e \Rightarrow P = 0,65 \cdot F_r + Y_2 \cdot F_a$$

Legend

P	N	Equivalent dynamic bearing load
F_r	N	Radial load
F_a	N	Axial load
e, Y_1, Y_2	-	Factors ▶ 386 f1 1, f1 2.

Equivalent static bearing load

For self-aligning ball bearings subjected to static load ▶ 378 | f1 3.

f3
Equivalent static load

$$P_0 = F_{0r} + Y_0 \cdot F_{0a}$$

Legend

P_0	N	Equivalent static bearing load
F_{0r}, F_{0a}	N	Largest radial or axial load present (maximum load)
Y_0	-	Axial load factor ▶ 386 f1 3.

Static load safety factor

$S_0 = C_0/P_0$

In addition to the basic rating life $L (L_{10h})$, it is also always necessary to check the static load safety factor S_0 ▶ 378 | f1 4.

f4
Static load safety factor

$$S_0 = \frac{C_0}{P_0}$$

Legend

S_0	-	Static load safety factor
C_0	N	Basic static load rating
P_0	N	Equivalent static bearing load.

1.15 Minimum load

In order to prevent damage due to slippage, a minimum radial load of $P > C_{0r}/100$ is required

In order that no slippage occurs between the contact partners, the self-aligning ball bearings must be constantly subjected to a sufficiently high load. Based on experience, a minimum radial load of the order of $P > C_{0r}/100$ is thus necessary. In most cases, however, the radial load is already higher than the requisite minimum load due to the weight of the supported parts and the external forces.



If the minimum radial load is lower than indicated above, please consult Schaeffler.

1.16 Design of bearing arrangements

☞ *Support bearing rings over their entire circumference and width*

In order to allow full utilisation of the load carrying capacity of the bearings and achieve the requisite rating life, the bearing rings must be rigidly and uniformly supported by means of contact surfaces over their entire circumference and over the entire width of the raceway. Support can be provided by means of a cylindrical or tapered seating surface ▶ 380|☞ 8 to ▶ 381|☞ 11. The seating and contact surfaces should not be interrupted by grooves, holes or other recesses. The accuracy of mating parts must meet specific requirements ▶ 381|☞ 6 to ▶ 382|☞ 8.

Radial location – fit recommendations for bearings with cylindrical bore

☞ *For secure radial location, tight fits are necessary*

In addition to supporting the rings adequately, the bearings must also be securely located in a radial direction, to prevent creep of the bearing rings on the mating parts under load. This is generally achieved by means of tight fits between the bearing rings and the mating parts. If the rings are not secured adequately or correctly, this can cause severe damage to the bearings and adjacent machine parts. Influencing factors, such as the conditions of rotation, magnitude of the load, internal clearance, temperature conditions, design of the mating parts and the mounting and dismounting options must be taken into consideration in the selection of fits.



If shock type loads occur, tight fits (transition fit or interference fit) are required to prevent the rings from coming loose at any point. Clearance, transition or interference fits ▶ 150|☞ 6 and ▶ 158|☞ 7.



The following information provided in Technical principles must be taken into consideration in the design of bearing arrangements:

- conditions of rotation ▶ 145
- tolerance classes for cylindrical shaft seats (radial bearings) ▶ 147|☞ 2
- shaft fits ▶ 150|☞ 6
- tolerance classes for bearing seats in housings (radial bearings) ▶ 148|☞ 4
- housing fits ▶ 158|☞ 7
- shaft tolerances for adapter sleeves and withdrawal sleeves ▶ 166|☞ 8.

Axial location – location methods for bearings with cylindrical bore

☞ *The bearings must also be securely located in an axial direction*

As a tight fit alone is not normally sufficient to also locate the bearing rings securely on the shaft and in the housing bore in an axial direction, this must usually be achieved by means of an additional axial location or retention method. The axial location of the bearing rings must be matched to the type of bearing arrangement. Shaft and housing shoulders, housing covers, nuts, spacer rings, retaining rings, adapter and withdrawal sleeves etc., are fundamentally suitable.



Simple location by means of a grub screw

Axial location – bearing series 112

Bearings of series 112 are axially located by means of a grub screw, which engages in the slot in the bearing inner ring >380| 8. The grub screw also prevents the inner ring creeping on the shaft.



If a shaft is to be supported by two bearings, the slots in the inner ring must either be arranged on the sides of the bearings facing towards or away from each other >380| 8.



Axial location of bearing series 112 using grub screw and arrangement of self-aligning ball bearings, where a shaft is supported by two bearings

- ① Grub screw

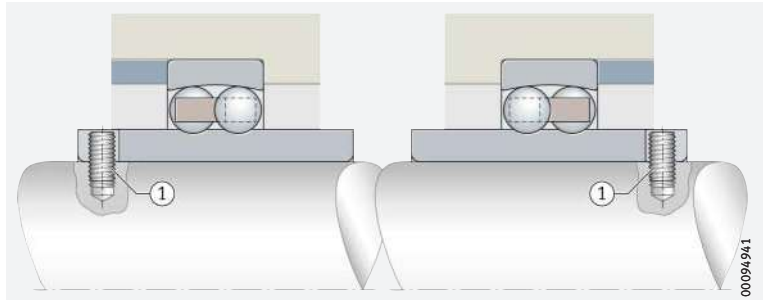

00094941

Location by means of locknut and tab washer

Axial location – bearings with tapered bore

If a bearing with a tapered bore is mounted directly on a tapered journal, the bearing can be axially located with ease using a locknut and tab washer >380| 9.



Self-aligning ball bearing with tapered bore, mounted directly on the tapered shaft journal

- ① Tapered journal with fixing thread
- ② Locknut
- ③ Tab washer

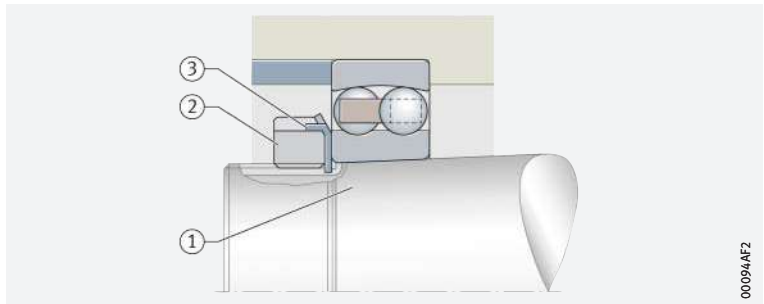

000944F2

Mounting can be carried out quickly and reliably by means of wrench sets from Schaeffler

Location of bearings by means of adapter sleeve

Self-aligning ball bearings with a tapered bore can be located easily and with operational liability on smooth or stepped cylindrical shafts by means of an adapter sleeve >380| 10. The adapter sleeve does not need to be secured on the shaft by any additional means. The bearings can be positioned at any point on smooth shafts. Axial load carrying capacity of bearing arrangements by means of adapter sleeve connection >372| 1.2.



Self-aligning ball bearing with adapter sleeve located on smooth shaft

- ① Adapter sleeve
- ② Locknut
- ③ Tab washer

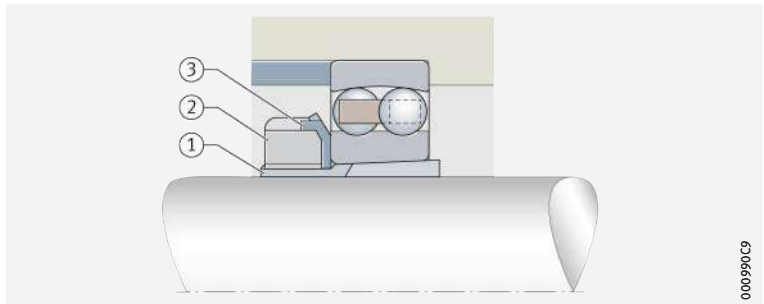

000990C9

Location by means of adapter sleeve, axial abutment by means of a support ring

If very high axial forces are present, a support ring can also be used to provide axial abutment ▶ 381 | ☐ 11. In this instance, the mounting dimensions of the support ring B_a and d_b in the product tables must be observed ▶ 386 | ▧.



Stepped shaft, axial abutment by means of a support ring

- ① Adapter sleeve
- ② Locknut
- ③ Tab washer
- ④ Support ring
- ⑤ Shaft shoulder

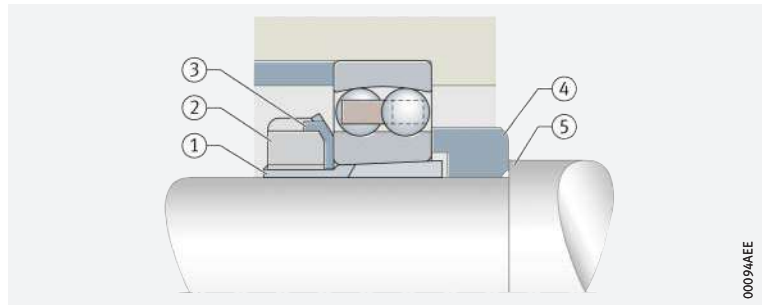

00094EE

Dimensional, geometrical and running accuracy of cylindrical bearing seats

☞ A minimum of IT6 should be provided for the shaft seat and a minimum of IT7 for the housing seat

The accuracy of the cylindrical bearing seat on the shaft and in the housing should correspond to the accuracy of the bearing used. For self-aligning ball bearings with the tolerance class Normal, the shaft seat should correspond to a minimum of standard tolerance grade IT6 and the housing seat to a minimum of IT7. Guide values for the geometrical and positional tolerances of bearing seating surfaces ▶ 381 | ▧ 6, tolerances t_1 to t_3 in accordance with ▶ 168 | ☐ 11. Numerical values for IT grades ▶ 381 | ▧ 7.



Guide values for the geometrical and positional tolerances of bearing seating surfaces

Bearing tolerance class		Bearing seating surface	Standard tolerance grades to ISO 286-1 (IT grades)			
to ISO 492	to DIN 620		Diameter tolerance	Roundness tolerance	Parallelism tolerance	Total axial runout tolerance of abutment shoulder
				t_1	t_2	t_3
Normal	PN (P0)	Shaft	IT6 (IT5)	Circumferential load IT4/2 Point load IT5/2	Circumferential load IT4/2 Point load IT5/2	IT4
		Housing	IT7 (IT6)	Circumferential load IT5/2 Point load IT6/2	Circumferential load IT5/2 Point load IT6/2	IT5



Numerical values for ISO standard tolerances (IT grades) to ISO 286-1:2010

IT grade	Nominal dimension in mm						
	over 18	30	50	80	120	180	250
	incl. 30	50	80	120	180	250	315
Values in μm							
IT4	6	7	8	10	12	14	16
IT5	9	11	13	15	18	20	23
IT6	13	16	19	22	25	29	32
IT7	21	25	30	35	40	46	52

Ra must not be too high

Roughness of cylindrical bearing seating surfaces

The roughness of the bearing seats must be matched to the tolerance class of the bearings. The mean roughness value Ra must not be too high, in order to maintain the interference loss within limits. The shafts must be ground, while the bores must be precision turned. Guide values as a function of the IT grade of bearing seating surfaces ▶ 382 | 8.

8
Roughness values
for cylindrical bearing seating
surfaces – guide values

Nominal diameter of the bearing seat d (D) mm		Recommended mean roughness value for ground bearing seats R _{max} μm			
		Diameter tolerance (IT grade)			
over	incl.	IT7	IT6	IT5	IT4
–	80	1,6	0,8	0,4	0,2
80	500	1,6	1,6	0,8	0,4

Tolerances for tapered bearing seats

For bearings located directly on a tapered shaft journal ▶ 380 | 9, the data are in accordance with ▶ 171 | 12.

Mounting dimensions for the contact surfaces of bearing rings

The mounting dimensions of the shaft and housing shoulders, and spacer rings etc., must ensure that the contact surfaces for the bearing rings are of sufficient height. However, they must also reliably prevent rotating parts of the bearing from grazing stationary parts. Proven mounting dimensions for the radii and diameters of the abutment shoulders ▶ 386 | 12. These dimensions are limiting dimensions (maximum or minimum dimensions); the actual values should not be higher or lower than specified.

Specifications for tapered bearing seats

The contact surfaces for the rings must be of sufficient height

Suitable bearing housings for self-aligning ball bearings

For economical, operationally reliable and easily interchangeable bearing arrangement units, the self-aligning ball bearings can also be combined with Schaeffler bearing housings ▶ 382 | 12. These easy-to-fit units fulfil all of the requirements for modern machine and plant designs with favourable maintenance-related characteristics.

A large range of housings is available



Due to the large number of application areas, an extensive range of bearing housings is available for bearings with cylindrical and tapered bores. These include split and unsplit plummer block housings, take-up housings, flanged housings and housings for specific industrial and railway applications. Detailed information on bearing housings can be found in publication GK 1 ▶ <https://www.schaeffler.de/std/1D54>. This book can be ordered from Schaeffler.

12
Split plummer block housing
with a self-aligning ball bearing

- ① Split plummer block housing SNV
- ② Self-aligning ball bearing

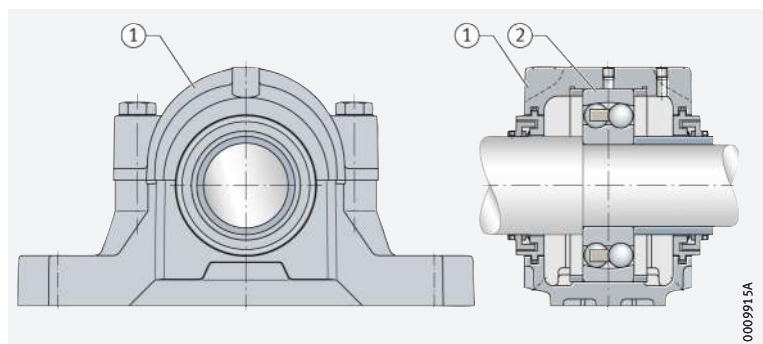

0009915A

1.17 Mounting and dismounting



The mounting and dismounting options for self-aligning ball bearings, by thermal, hydraulic or mechanical methods, must be taken into consideration in the design of the bearing position.

☞ *Ensure that the bearings are not damaged during mounting*

Self-aligning ball bearings are not separable. In the mounting of non-separable bearings, the mounting forces must always be applied to the bearing ring with a tight fit.

☞ *Suitable methods*

Mounting of bearings with a tapered bore

Bearings with a tapered bore are mounted with a tight fit on the shaft or adapter and withdrawal sleeve. The measurement of the reduction in radial internal clearance or of the axial drive-up distance of the inner ring on the tapered bearing seat serves as an indication of the tight fit.

☞ *The measurement is usually carried out with a feeler gauge*

Measuring the reduction in radial internal clearance

The reduction in radial internal clearance is the difference between the radial internal clearance before mounting and the bearing clearance after mounting of the bearing ► 383 | ☐ 13. The radial internal clearance must be measured first. During pressing on, the radial clearance (bearing clearance) must be checked until the necessary reduction in the radial internal clearance and thus the required tight fit is achieved.



13
Reduction in radial internal clearance

- s_r = radial internal clearance before mounting
- s_{r1} = radial internal clearance after mounting
- $s_r - s_{r1}$ = reduction in radial internal clearance

- ① Before mounting
- ② After mounting

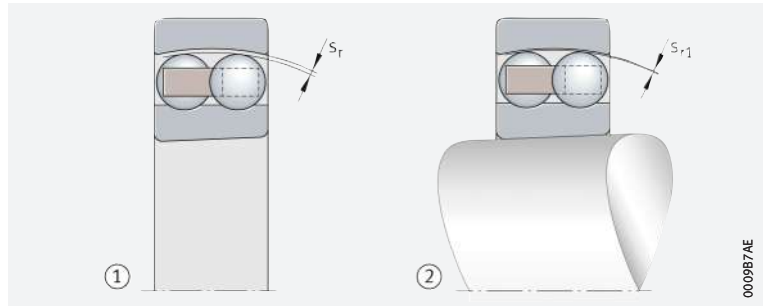

Measuring the axial drive-up distance

The axial drive-up distance can also be measured in place of the reduction in radial internal clearance ► 383 | ☐ 14.



14
Axial drive-up distance

- s_a = axial press-on distance (axial drive-up distance of the bearing)
- s_r = radial internal clearance
- s_{r1} = radial internal clearance after pressing on
- $s_r - s_{r1}$ = reduction in radial internal clearance

- ① Before pressing on
- ② After pressing on

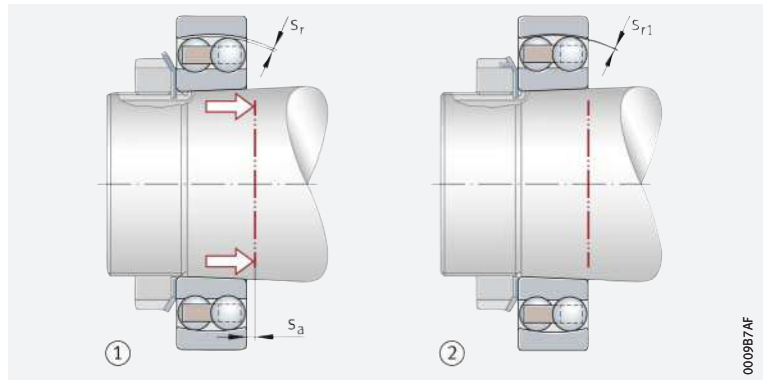

The malfunction-free operation of bearings presupposes that these have been mounted correctly. An insufficient operating clearance or inadequately tight fit on the shaft generally leads to bearing damage.



If there is any uncertainty regarding the practical application of both methods, Schaeffler must always be consulted.



The mounting of self-aligning ball bearings is also described in the Schaeffler publication BA 28. This BA publication can be requested from Schaeffler.

📖 *Rolling bearings must be handled with great care*

Schaeffler Mounting Handbook

Rolling bearings are well-proven precision machine elements for the design of economical and reliable bearing arrangements, which offer high operational security. In order that these products can function correctly and achieve the envisaged operating life without detrimental effect, they must be handled with care.



The Schaeffler Mounting Handbook MH 1 gives comprehensive information about the correct storage, mounting, dismounting and maintenance of rotary rolling bearings ➤ <https://www.schaeffler.de/std/1D53>. It also provides information which should be observed by the designer, in relation to the mounting, dismounting and maintenance of bearings, in the original design of the bearing position. This book is available from Schaeffler on request.

1.18

Legal notice regarding data freshness

📖 *The further development of products may also result in technical changes to catalogue products*

Of central interest to Schaeffler is the further development and optimisation of its products and the satisfaction of its customers. In order that you, as the customer, can keep yourself optimally informed about the progress that is being made here and with regard to the current technical status of the products, we publish any product changes which differ from the printed version in our electronic product catalogue.



We therefore reserve the right to make changes to the data and illustrations in this catalogue. This catalogue reflects the status at the time of printing. More recent publications released by us (as printed or digital media) will automatically precede this catalogue if they involve the same subject. Therefore, please always use our electronic product catalogue to check whether more up-to-date information or modification notices exist for your desired product.

Link to electronic product catalogue



The following link will take you to the Schaeffler electronic product catalogue: ➤ <https://medias.schaeffler.com>.

1.19

Further information



In addition to the data in this chapter, the following chapters in Technical principles must also be observed in the design of bearing arrangements:

- Determining the bearing size ➤ 34
- Rigidity ➤ 54
- Friction and increases in temperature ➤ 56
- Speeds ➤ 64
- Bearing data ➤ 97
- Lubrication ➤ 70
- Sealing ➤ 182
- Design of bearing arrangements ➤ 139
- Mounting and dismounting ➤ 191.





Self-aligning ball bearings

With cylindrical or tapered bore

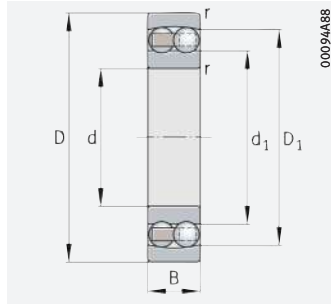

Cylindrical bore

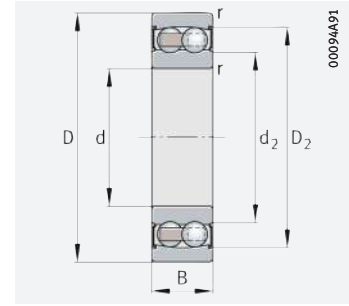

Cylindrical bore with seal 2RS

d = 5 – 20 mm

Main dimensions			Basic load ratings		Fatigue limit load C_{ur} N	Limiting speed n_G min^{-1}	Speed rating $n_{\theta r}$ min^{-1}	Mass m \approx kg	Designation ► 377 1.12 ► 377 1.13
d	D	B	dyn. C_r N	stat. C_{0r} N					
5	19	6	2 600	475	29,5	41 500	24 500	0,01	135-TVH
6	19	6	2 600	475	29,5	41 500	30 500	0,009	126-TVH
7	22	7	2 750	560	34,5	39 000	26 500	0,014	127-TVH
8	22	7	2 750	560	34,5	39 000	27 000	0,014	108-TVH
9	26	8	3 950	800	50	33 500	24 100	0,022	129-TVH
10	30	9	5 700	1 180	73	29 500	22 100	0,034	1200-TVH
	30	14	5 700	1 180	73	16 500	27 000	0,053	2200-2RS-TVH
	30	14	8 800	1 730	107	25 500	26 000	0,045	2200-TVH
12	32	10	5 700	1 250	78	28 000	21 300	0,041	1201-TVH
	32	14	5 700	1 250	78	14 700	27 000	0,058	2201-2RS-TVH
	32	14	9 400	1 920	120	24 200	23 300	0,05	2201-TVH
	37	12	9 800	2 140	133	22 300	16 200	0,067	1301-TVH
15	35	11	7 700	1 730	108	23 800	19 100	0,048	1202-TVH
	35	14	7 700	1 730	108	13 300	27 000	0,061	2202-2RS-TVH
	35	14	9 600	2 080	130	22 200	19 600	0,057	2202-TVH
	42	17	9 800	2 260	141	11 200	27 000	0,114	2302-2RS-TVH
	42	17	17 400	3 800	237	17 200	15 600	0,111	2302-TVH
17	40	12	8 100	2 000	124	21 800	17 400	0,073	1203-TVH
	40	16	8 100	2 000	124	11 300	27 000	0,098	2203-2RS-TVH
	40	16	11 800	2 750	171	19 100	17 400	0,088	2203-TVH
	47	14	12 900	3 150	197	17 800	13 300	0,065	1303-TVH
	47	19	12 900	3 150	197	10 100	27 000	0,175	2303-2RS-TVH
	47	19	13 900	3 150	197	17 000	14 900	0,155	2303-TVH
20	47	14	10 100	2 600	161	18 100	15 300	0,116	1204-K-TVH-C3
	47	14	10 100	2 600	161	18 100	15 300	0,118	1204-TVH
	47	18	10 100	2 600	161	9 400	–	0,151	2204-2RS-TVH
	47	18	14 700	3 500	219	16 300	15 600	0,134	2204-TVH
	52	15	12 700	3 300	206	16 100	11 600	0,163	1304-TVH
	52	21	12 700	3 300	206	8 500	–	0,23	2304-2RS-TVH
	52	21	17 600	4 250	265	15 000	13 800	0,206	2304-TVH

medias ► <https://www.schaeffler.de/std/1D7E>

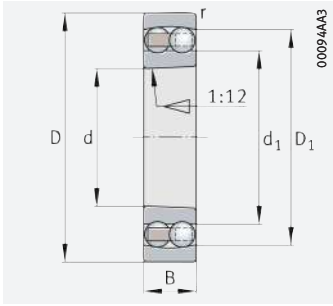

Tapered bore

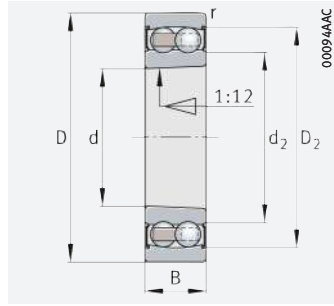

Tapered bore
with seal 2RS

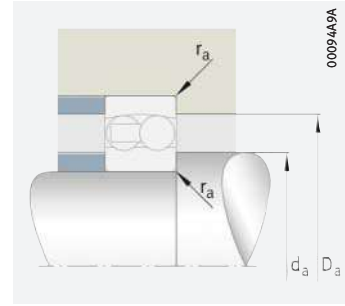

Mounting dimensions

Dimensions						Mounting dimensions			Calculation factors			
d	r	D ₁	D ₂	d ₁	d ₂	d _a	D _a	r _a	e	Y ₁	Y ₂	Y ₀
	min.	≈	≈	≈	≈	min.	max.	max.				
5	0,3	14,5	–	10,1	–	7,4	16,6	0,3	0,35	1,82	2,82	1,91
6	0,3	14,7	–	10,1	–	8,4	16,6	0,3	0,35	1,82	2,82	1,91
7	0,3	17,1	–	12,4	–	9,4	19,6	0,3	0,33	1,92	2,97	2,01
8	0,3	16,8	–	12,4	–	10,6	19,4	0,3	0,33	1,92	2,97	2,01
9	0,6	20	–	14,5	–	13,2	21,8	0,6	0,32	1,95	3,01	2,04
10	0,6	23,3	–	16,3	–	14,2	25,8	0,6	0,32	1,95	3,02	2,05
	0,6	–	25,2	–	14,1	14,2	25,8	0,6	0,32	1,95	3,02	2,05
	0,6	24	–	15,1	–	14,2	25,8	0,6	0,58	1,09	1,69	1,14
12	0,6	25,1	–	18,2	–	16,2	27,8	0,6	0,37	1,69	2,62	1,77
	0,6	–	27,2	–	16,2	16,2	27,8	0,6	0,37	1,69	2,62	1,77
	0,6	25,9	–	17,1	–	16,2	27,8	0,6	0,53	1,2	1,85	1,25
	1	29,7	–	20,3	–	17,6	31,4	1	0,35	1,8	2,79	1,89
15	0,6	28,8	–	20,2	–	19,2	30,8	0,6	0,34	1,86	2,88	1,95
	0,6	–	30,2	–	19	19,2	30,8	0,6	0,34	1,86	2,88	1,95
	0,6	29,2	–	20,3	–	19,2	30,8	0,6	0,46	1,37	2,13	1,44
	1	–	34,9	–	23,9	20,6	36,4	1	0,35	1,79	2,77	1,88
	1	34,4	–	22,5	–	20,6	36,4	1	0,51	1,23	1,91	1,29
17	0,6	32	–	23,7	–	21,2	35,8	0,6	0,33	1,93	2,99	2,03
	0,6	–	34,3	–	21,6	21,2	35,8	0,6	0,33	1,93	2,99	2,03
	0,6	33,9	–	23,9	–	21,2	35,8	0,6	0,46	1,37	2,12	1,43
	1	37	–	26,7	–	22,6	41,4	1	0,32	1,94	3	2,03
	1	–	39,4	–	23,9	22,6	41,4	1	0,32	1,94	3	2,03
	1	37,3	–	26,2	–	22,6	41,4	1	0,53	1,19	1,85	1,25
20	1	37,8	–	29,2	–	25,6	41,4	1	0,28	2,24	3,46	2,34
	1	37,8	–	29,2	–	25,6	41,4	1	0,28	2,24	3,46	2,34
	1	–	41	–	25,8	25,6	41,4	1	0,28	2,24	3,46	2,34
	1	39,1	–	28	–	25,6	41,4	1	0,44	1,45	2,24	1,51
	1,1	41,5	–	31,6	–	27	45	1	0,29	2,17	3,35	2,27
	1,1	–	44,4	–	27,2	27	45	1	0,29	2,17	3,35	2,27
	1,1	41,2	–	29,1	–	27	45	1	0,51	1,23	1,9	1,29





Self-aligning ball bearings

With cylindrical or tapered bore

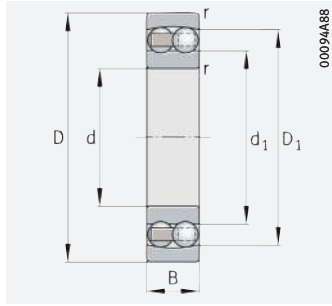

Cylindrical bore

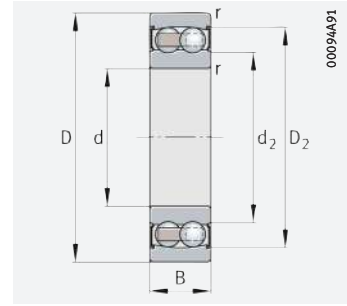

Cylindrical bore with seal 2RS

d = 25 – 35 mm

Main dimensions			Basic load ratings		Fatigue limit load C_{ur} N	Limiting speed n_G min ⁻¹	Speed rating n_{Dr} min ⁻¹	Mass m ≈ kg	Designation ➤ 377 1.12 ➤ 377 1.13
d	D	B	dyn. C_r N	stat. C_{Or} N					
25	52	15	12 300	3 250	203	15 500	13 400	0,135	1205-K-TVH-C3
	52	15	12 300	3 250	203	15 500	13 400	0,138	1205-TVH
	52	18	12 300	3 250	203	8 100	–	0,161	2205-2RS-TVH
	52	18	12 300	3 250	203	8 100	–	0,157	2205-K-2RS-TVH-C3
	52	18	17 300	4 400	275	14 400	13 400	0,152	2205-K-TVH-C3
	52	18	17 300	4 400	275	14 400	13 400	0,156	2205-TVH
	62	17	18 300	4 950	310	12 900	10 000	0,254	1305-K-TVH-C3
	62	17	18 300	4 950	310	12 900	10 000	0,258	1305-TVH
	62	24	18 300	4 950	310	7 000	–	0,367	2305-2RS-TVH
	62	24	25 000	6 500	405	12 200	11 900	0,328	2305-K-TVH-C3
62	24	25 000	6 500	405	12 200	11 900	0,335	2305-TVH	
30	62	16	15 900	4 600	285	13 100	11 400	0,217	1206-K-TVH-C3
	62	16	15 900	4 600	285	13 100	11 400	0,221	1206-TVH
	62	20	15 900	4 600	285	6 800	–	0,274	2206-2RS-TVH
	62	20	15 900	4 600	285	6 800	–	0,268	2206-K-2RS-TVH-C3
	62	20	26 000	6 900	425	11 500	11 400	0,246	2206-K-TVH-C3
	62	20	26 000	6 900	425	11 500	11 400	0,252	2206-TVH
	72	19	21 700	6 300	390	11 100	8 700	0,379	1306-K-TVH-C3
	72	19	21 700	6 300	390	11 100	8 700	0,384	1306-TVH
	72	27	21 700	6 300	390	5 900	–	0,554	2306-2RS-TVH
	72	27	32 500	8 700	540	10 200	10 400	0,476	2306-K-TVH-C3
72	27	32 500	8 700	540	10 200	10 400	0,488	2306-TVH	
35	72	17	16 000	5 100	315	11 600	9 800	0,319	1207-K-TVH-C3
	72	17	16 000	5 100	315	11 600	9 800	0,324	1207-TVH
	72	23	16 000	5 100	315	5 600	–	0,442	2207-2RS-TVH
	72	23	16 000	5 100	315	5 600	–	0,432	2207-K-2RS-TVH-C3
	72	23	33 000	8 900	560	9 800	10 300	0,38	2207-K-TVH-C3
	72	23	33 000	8 900	560	9 800	10 300	0,389	2207-TVH
	80	21	25 500	7 800	485	9 700	7 800	0,5	1307-K-TVH-C3
	80	21	25 500	7 800	485	9 700	7 800	0,507	1307-TVH
	80	31	25 500	7 800	485	5 200	–	0,744	2307-2RS-TVH
	80	31	40 500	11 100	690	8 900	9 800	0,657	2307-K-TVH-C3
	80	31	40 500	11 100	690	8 900	9 800	0,675	2307-TVH

medias ➤ <https://www.schaeffler.de/std/1D7F>

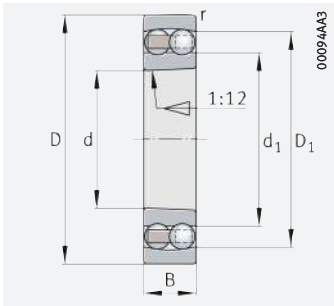

Tapered bore

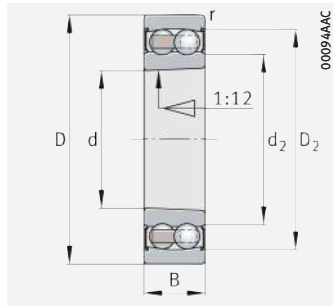

Tapered bore with seal 2RS

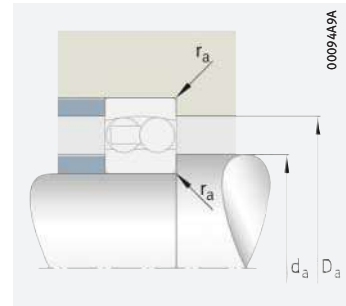

Mounting dimensions

Dimensions						Mounting dimensions			Calculation factors			
d	r	D ₁	D ₂	d ₁	d ₂	d _a	D _a	r _a	e	Y ₁	Y ₂	Y ₀
	min.	≈	≈	≈	≈	min.	max.	max.				
25	1	43,6	–	33,3	–	30,6	46,4	1	0,27	2,37	3,66	2,48
	1	43,6	–	33,3	–	30,6	46,4	1	0,27	2,37	3,66	2,48
	1	–	45,3	–	30,7	30,6	46,4	1	0,27	2,37	3,66	2,48
	1	–	45,3	–	30,7	30,6	46,4	1	0,27	2,37	3,66	2,48
	1	44,4	–	32,3	–	30,6	46,4	1	0,35	1,78	2,75	1,86
	1	44,4	–	32,3	–	30,6	46,4	1	0,35	1,78	2,75	1,86
	1,1	50,4	–	38,1	–	32	55	1	0,28	2,29	3,54	2,4
	1,1	50,4	–	38,1	–	32	55	1	0,28	2,29	3,54	2,4
	1,1	–	52,4	–	33,5	32	55	1	0,28	2,29	3,54	2,4
	1,1	49,9	–	35,5	–	32	55	1	0,48	1,32	2,04	1,38
1,1	49,9	–	35,5	–	32	55	1	0,48	1,32	2,04	1,38	
30	1	51,6	–	40,1	–	35,6	56,4	1	0,25	2,53	3,91	2,65
	1	51,6	–	40,1	–	35,6	56,4	1	0,25	2,53	3,91	2,65
	1	–	53,3	–	37,3	35,6	56,4	1	0,25	2,53	3,91	2,65
	1	–	53,3	–	37,3	35,6	56,4	1	0,25	2,53	3,91	2,65
	1	53,7	–	38,5	–	35,6	56,4	1	0,3	2,13	3,29	2,23
	1	53,7	–	38,5	–	35,6	56,4	1	0,3	2,13	3,29	2,23
	1,1	58,9	–	45,1	–	37	65	1	0,26	2,39	3,71	2,51
	1,1	58,9	–	45	–	37	65	1	0,26	2,39	3,71	2,51
	1,1	–	62,3	–	40,6	37	65	1	0,26	2,39	3,71	2,51
	1,1	58,8	–	41,5	–	37	65	1	0,45	1,4	2,17	1,47
1,1	58,8	–	41,5	–	37	65	1	0,45	1,4	2,17	1,47	
35	1,1	59,1	–	47,7	–	42	65	1	0,22	2,8	4,34	2,94
	1,1	59,1	–	47,7	–	42	65	1	0,22	2,8	4,34	2,94
	1,1	–	63,4	–	43,5	42	65	1	0,22	2,8	4,34	2,94
	1,1	–	63,4	–	43,5	42	65	1	0,22	2,8	4,34	2,94
	1,1	62,4	–	45,7	–	42	65	1	0,3	2,13	3,29	2,23
	1,1	62,4	–	45,7	–	42	65	1	0,3	2,13	3,29	2,23
	1,5	70,1	–	51,3	–	44	71	1,5	0,26	2,47	3,82	2,59
	1,5	70,1	–	51,3	–	44	71	1,5	0,26	2,47	3,82	2,59
	1,5	–	68,4	–	44,9	44	71	1,5	0,26	2,47	3,82	2,59
	1,5	66,1	–	46,9	–	44	71	1,5	0,47	1,35	2,1	1,42
	1,5	66,1	–	46,9	–	44	71	1,5	0,47	1,35	2,1	1,42





Self-aligning ball bearings

With cylindrical or tapered bore

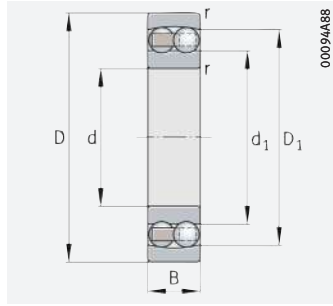

Cylindrical bore

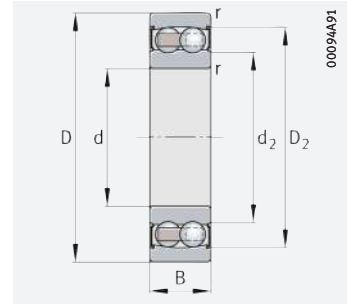

Cylindrical bore with seal 2RS

d = 40 – 50 mm

Main dimensions			Basic load ratings		Fatigue limit load	Limiting speed	Speed rating	Mass	Designation
d	D	B	dyn. C_r N	stat. C_{0r} N	C_{ur} N	n_G min^{-1}	$n_{\theta r}$ min^{-1}	m \approx kg	▶ 377 1.12 ▶ 377 1.13
40	80	18	19 400	6 500	400	10 100	8 600	0,408	1208-K-TVH-C3
	80	18	19 400	6 500	400	10 100	8 600	0,414	1208-TVH
	80	23	19 400	6 500	400	4 950	–	0,528	2208-2RS-TVH
	80	23	19 400	6 500	400	4 950	–	0,517	2208-K-2RS-TVH-C3
	80	23	32 500	9 400	580	8 900	8 700	0,465	2208-K-TVH-C3
	80	23	32 500	9 400	580	8 900	8 700	0,476	2208-TVH
	90	23	30 000	9 600	600	8 600	7 200	0,698	1308-K-TVH-C3
	90	23	30 000	9 600	600	8 600	7 200	0,708	1308-TVH
	90	33	30 000	9 600	600	4 650	–	1,01	2308-2RS-TVH
	90	33	46 000	13 400	830	7 900	8 700	0,899	2308-K-TVH-C3
90	33	46 000	13 400	830	7 900	8 700	0,922	2308-TVH	
45	85	19	22 000	7 300	455	9 300	8 200	0,454	1209-K-TVH-C3
	85	19	22 000	7 300	455	9 300	8 200	0,462	1209-TVH
	85	23	22 000	7 300	455	4 650	–	0,548	2209-2RS-TVH
	85	23	22 000	7 300	455	4 650	–	0,535	2209-K-2RS-TVH-C3
	85	23	28 500	8 900	550	8 600	7 800	0,505	2209-K-TVH-C3
	85	23	28 500	8 900	550	8 600	7 800	0,517	2209-TVH
	100	25	38 500	12 600	780	7 500	6 700	0,939	1309-K-TVH-C3
	100	25	38 500	12 600	780	7 500	6 700	0,953	1309-TVH
	100	36	38 500	12 600	780	4 200	–	1,34	2309-2RS-TVH
	100	36	55 000	16 500	1 030	7 000	8 000	1,19	2309-K-TVH-C3
100	36	55 000	16 500	1 030	7 000	8 000	1,22	2309-TVH	
50	90	20	22 900	8 000	500	8 700	7 700	0,516	1210-K-TVH-C3
	90	20	22 900	8 000	500	8 700	7 700	0,526	1210-TVH
	90	23	22 900	8 000	500	4 250	–	0,606	2210-2RS-TVH
	90	23	22 900	8 000	500	4 250	–	0,593	2210-K-2RS-TVH-C3
	90	23	28 500	9 400	580	8 100	7 100	0,543	2210-K-TVH-C3
	90	23	28 500	9 400	580	8 100	7 100	0,556	2210-TVH
	110	27	42 000	14 100	880	6 900	6 300	1,19	1310-K-TVH-C3
	110	27	42 000	14 100	880	6 900	6 300	1,21	1310-TVH
	110	40	42 000	14 100	880	3 750	–	1,82	2310-2RS-TVH
	110	40	66 000	20 100	1 250	6 300	7 600	1,64	2310-TVH

medias ▶ <https://www.schaeffler.de/std/1D80>

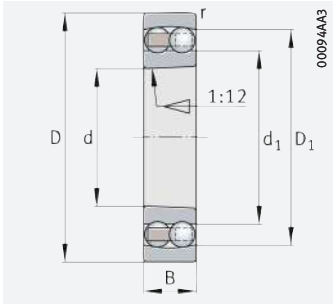

Tapered bore

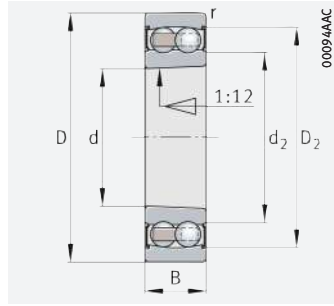

Tapered bore with seal 2RS

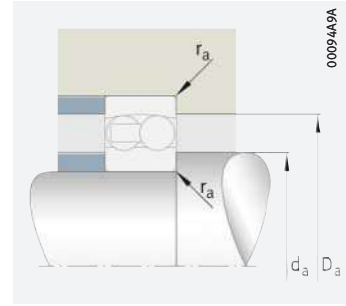

Mounting dimensions

Dimensions						Mounting dimensions			Calculation factors			
d	r	D ₁	D ₂	d ₁	d ₂	d _a	D _a	r _a	e	Y ₁	Y ₂	Y ₀
	min.	≈	≈	≈	≈	min.	max.	max.				
40	1,1	67,3	–	54	–	47	73	1	0,22	2,9	4,49	3,04
	1,1	67,3	–	54	–	47	73	1	0,22	2,9	4,49	3,04
	1,1	–	70,3	–	49,2	47	73	1	0,22	2,9	4,49	3,04
	1,1	–	70,3	–	49,2	47	73	1	0,22	2,9	4,49	3,04
	1,1	70,2	–	52,5	–	47	73	1	0,26	2,43	3,76	2,54
	1,1	70,2	–	52,5	–	47	73	1	0,26	2,43	3,76	2,54
	1,5	74,7	–	57,8	–	49	81	1,5	0,25	2,52	3,9	2,64
	1,5	74,7	–	57,8	–	49	81	1,5	0,25	2,52	3,9	2,64
	1,5	–	77,3	–	51	49	81	1,5	0,25	2,52	3,9	2,64
	1,5	74,5	–	53,7	–	49	81	1,5	0,43	1,45	2,25	1,52
1,5	74,5	–	53,7	–	49	81	1,5	0,43	1,45	2,25	1,52	
45	1,1	72,1	–	57,7	–	52	78	1	0,21	3,04	4,7	3,18
	1,1	72,1	–	57,7	–	52	78	1	0,21	3,04	4,7	3,18
	1,1	–	76	–	53,8	52	78	1	0,21	3,04	4,7	3,18
	1,1	–	76	–	53,8	52	78	1	0,21	3,04	4,7	3,18
	1,1	75,4	–	59	–	52	78	1	0,26	2,43	3,76	2,54
	1,1	75,4	–	59	–	52	78	1	0,26	2,43	3,76	2,54
	1,5	83,5	–	64,1	–	54	91	1,5	0,25	2,5	3,87	2,62
	1,5	83,5	–	64,1	–	54	91	1,5	0,25	2,5	3,87	2,62
	1,5	–	85,8	–	57,5	54	91	1,5	0,25	2,5	3,87	2,62
	1,5	83,6	–	60,1	–	54	91	1,5	0,43	1,48	2,29	1,55
1,5	83,6	–	60,1	–	54	91	1,5	0,43	1,48	2,29	1,55	
50	1,1	77,1	–	62,7	–	57	83	1	0,2	3,17	4,9	3,32
	1,1	77,1	–	62,7	–	57	83	1	0,2	3,17	4,9	3,32
	1,1	–	79	–	60,5	57	83	1	0,2	3,17	4,9	3,32
	1,1	–	79	–	60,5	57	83	1	0,2	3,17	4,9	3,32
	1,1	80,5	–	64	–	57	83	1	0,24	2,61	4,05	2,74
	1,1	80,5	–	64	–	57	83	1	0,24	2,61	4,05	2,74
	2	91,7	–	71,2	–	61	99	2	0,24	2,6	4,03	2,73
	2	91,7	–	71,2	–	61	99	2	0,24	2,6	4,03	2,73
	2	–	95,1	–	65,9	61	99	2	0,24	2,6	4,03	2,73
	2	91,4	–	65,9	–	61	99	2	0,43	1,47	2,27	1,54





Self-aligning ball bearings

With cylindrical or tapered bore

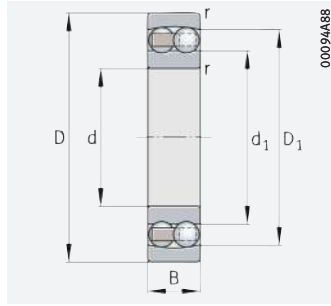

Cylindrical bore

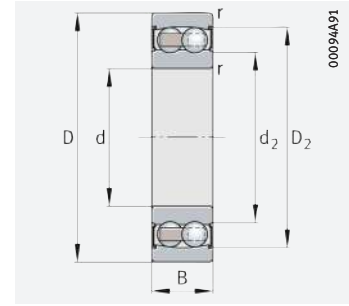

Cylindrical bore with seal 2RS

d = 55 – 65 mm

Main dimensions			Basic load ratings		Fatigue limit load	Limiting speed	Speed rating	Mass	Designation
d	D	B	dyn. C_r N	stat. C_{0r} N	C_{ur} N	n_G min^{-1}	$n_{\theta r}$ min^{-1}	m \approx kg	▶ 377 1.12 ▶ 377 1.13
55	100	21	27 000	9 900	620	7 700	6 900	0,682	1211-K-TVH-C3
	100	21	27 000	9 900	620	7 700	6 900	0,693	1211-TVH
	100	25	27 000	9 900	620	3 850	–	0,825	2211-2RS-TVH
	100	25	27 000	9 900	620	3 850	–	0,808	2211-K-2RS-TVH-C3
	100	25	39 000	12 400	770	7 000	6 700	0,73	2211-K-TVH-C3
	100	25	39 000	12 400	770	7 000	6 700	0,746	2211-TVH
	120	29	52 000	17 700	1 100	6 100	5 800	1,55	1311-K-TVH-C3
	120	29	52 000	17 700	1 100	6 100	5 800	1,57	1311-TVH
	120	43	52 000	17 700	1 100	3 450	–	2,28	2311-2RS-TVH
	120	43	77 000	23 800	1 480	5 700	7 100	2,02	2311-K-TVH-C3
	120	43	77 000	23 800	1 480	5 700	7 100	2,07	2311-TVH
60	110	22	30 500	11 400	710	6 900	6 300	0,88	1212-K-TVH-C3
	110	22	30 500	11 400	710	6 900	6 300	0,894	1212-TVH
	110	28	30 500	11 400	710	3 450	–	1,13	2212-2RS-TVH
	110	28	30 500	11 400	710	3 450	–	1,13	2212-K-2RS-TVH-C3
	110	28	48 000	16 300	1 020	6 300	6 400	1,03	2212-K-TVH-C3
	110	28	48 000	16 300	1 020	6 300	6 400	1,06	2212-TVH
	130	31	58 000	20 600	1 280	5 500	5 200	1,94	1312-K-TVH-C3
	130	31	58 000	20 600	1 280	5 500	5 200	1,97	1312-TVH
	130	46	89 000	28 000	1 740	5 200	6 700	2,52	2312-K-TVH-C3
130	46	89 000	28 000	1 740	5 200	6 700	2,58	2312-TVH	
65	120	23	31 000	12 400	770	6 500	5 800	1,13	1213-K-TVH-C3
	120	23	31 000	12 400	770	6 500	5 800	1,14	1213-TVH
	120	31	31 000	12 400	770	3 150	–	1,53	2213-2RS-TVH
	120	31	31 000	12 400	770	3 150	–	1,5	2213-K-2RS-TVH-C3
	120	31	58 000	19 000	1 190	5 600	6 200	1,33	2213-K-TVH-C3
	120	31	58 000	19 000	1 190	5 600	6 200	1,36	2213-TVH
	140	33	63 000	22 700	1 380	5 200	5 100	2,41	1313-K-TVH-C3
	140	33	63 000	22 700	1 380	5 200	5 100	2,44	1313-TVH
	140	48	98 000	32 000	1 980	4 750	6 100	3,16	2313-K-TVH-C3
	140	48	98 000	32 000	1 980	4 750	6 100	3,23	2313-TVH

medias ▶ <https://www.schaeffler.de/std/1D81>

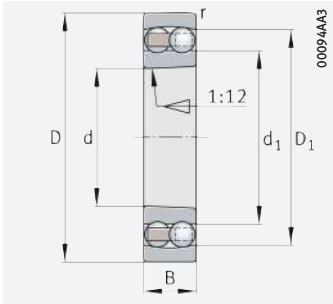

Tapered bore

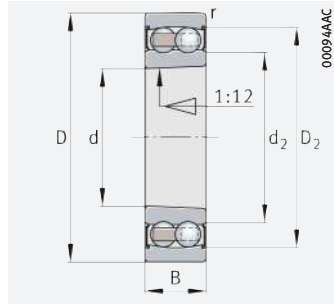

Tapered bore with seal 2RS

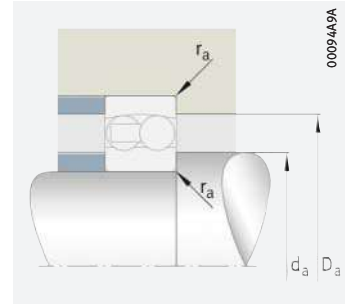

Mounting dimensions

Dimensions						Mounting dimensions			Calculation factors			
d	r	D ₁	D ₂	d ₁	d ₂	d _a	D _a	r _a	e	Y ₁	Y ₂	Y ₀
	min.	≈	≈	≈	≈	min.	max.	max.				
55	1,5	86,4	–	69,5	–	64	91	1,5	0,19	3,31	5,12	3,47
	1,5	86,4	–	69,5	–	64	91	1,5	0,19	3,31	5,12	3,47
	1,5	–	88,2	–	68	64	91	1,5	0,19	3,31	5,12	3,47
	1,5	–	88,2	–	68	64	91	1,5	0,19	3,31	5,12	3,47
	1,5	89,8	–	69,6	–	64	91	1,5	0,22	2,92	4,52	3,06
	1,5	89,8	–	69,6	–	64	91	1,5	0,22	2,92	4,52	3,06
	2	101	–	78	–	66	109	2	0,24	2,66	4,12	2,79
	2	101	–	78	–	66	109	2	0,24	2,66	4,12	2,79
	2	–	106,4	–	70,5	66	109	2	0,24	2,66	4,12	2,79
	2	100,2	–	71,7	–	66	109	2	0,42	1,51	2,33	1,58
2	100,2	–	71,7	–	66	109	2	0,42	1,51	2,33	1,58	
60	1,5	95,2	–	78	–	69	101	1,5	0,18	3,47	5,37	3,64
	1,5	95,2	–	78	–	69	101	1,5	0,18	3,47	5,37	3,64
	1,5	–	99,5	–	70,4	69	101	1,5	0,18	3,47	5,37	3,64
	1,5	–	99,5	–	70,4	69	101	1,5	0,18	3,47	5,37	3,64
	1,5	98,2	–	76,6	–	69	101	1,5	0,23	2,69	4,16	2,82
	1,5	98,2	–	76,6	–	69	101	1,5	0,23	2,69	4,16	2,82
	2,1	112,2	–	87	–	72	118	2,1	0,23	2,77	4,28	2,9
	2,1	112,2	–	87	–	72	118	2,1	0,23	2,77	4,28	2,9
	2,1	108,5	–	77	–	72	118	2,1	0,41	1,55	2,4	1,62
	2,1	108,5	–	77	–	72	118	2,1	0,41	1,55	2,4	1,62
65	1,5	102,7	–	85,2	–	74	111	1,5	0,18	3,57	5,52	3,74
	1,5	102,7	–	85,2	–	74	111	1,5	0,18	3,57	5,52	3,74
	1,5	–	107,8	–	78	74	111	1,5	0,18	3,57	5,52	3,74
	1,5	–	107,8	–	78	74	111	1,5	0,18	3,57	5,52	3,74
	1,5	106,9	–	82,4	–	74	111	1,5	0,23	2,78	4,31	2,92
	1,5	106,9	–	82,4	–	74	111	1,5	0,23	2,78	4,31	2,92
	2,1	118,2	–	92,7	–	77	128	2,1	0,23	2,75	4,26	2,88
	2,1	118,2	–	92,7	–	77	128	2,1	0,23	2,75	4,26	2,88
	2,1	118,3	–	85,6	–	77	128	2,1	0,39	1,62	2,51	1,7
	2,1	118,3	–	85,6	–	77	128	2,1	0,39	1,62	2,51	1,7





Self-aligning ball bearings

With cylindrical or tapered bore

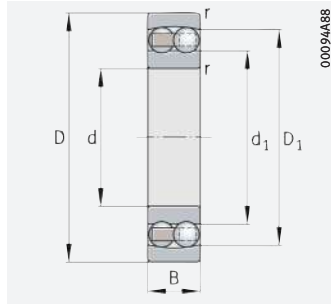

Cylindrical bore

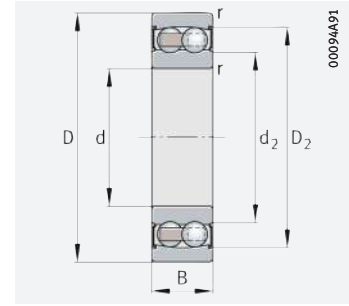

Cylindrical bore with seal 2RS

d = 70 – 85 mm

Main dimensions			Basic load ratings		Fatigue limit load	Limiting speed	Speed rating	Mass	Designation
d	D	B	dyn. C_r N	stat. C_{0r} N	C_{Ur} N	n_G min^{-1}	$n_{\theta r}$ min^{-1}	m \approx kg	▶ 377 1.12 ▶ 377 1.13
70	125	24	35 000	13 700	850	6 200	5 900	1,23	1214-K-TVH-C3
	125	24	35 000	13 700	850	6 200	5 900	1,25	1214-TVH
	125	31	35 000	13 700	850	3 050	–	1,59	2214-2RS-TVH
	125	31	44 000	16 900	1 050	8 800	5 900	1,69	2214-M
	150	35	75 000	27 500	1 620	7 200	4 950	3,11	1314-M
	150	51	112 000	37 000	2 210	6 600	5 800	4,38	2314-M
75	130	25	39 000	15 600	950	5 700	5 500	1,32	1215-K-TVH-C3
	130	25	39 000	15 600	950	5 700	5 500	1,34	1215-TVH
	130	31	44 500	17 600	1 080	5 600	5 600	1,6	2215-K-TVH-C3
	130	31	44 500	17 600	1 080	5 600	5 600	1,6	2215-TVH
	160	37	80 000	29 500	1 690	6 700	4 750	3,52	1315-K-M-C3
	160	37	80 000	29 500	1 690	6 700	4 750	3,56	1315-M
	160	55	125 000	42 000	2 420	6 100	5 600	5,21	2315-K-M-C3
	160	55	125 000	42 000	2 420	6 100	5 600	5,33	2315-M
80	140	26	40 000	16 800	990	5 300	5 100	1,62	1216-K-TVH-C3
	140	26	40 000	16 800	990	5 300	5 100	1,65	1216-TVH
	140	33	49 500	19 800	1 180	5 300	5 400	1,97	2216-K-TVH-C3
	140	33	49 500	19 800	1 180	5 300	5 400	2,01	2216-TVH
	170	39	89 000	33 000	1 810	6 200	4 500	4,5	1316-K-M-C3
	170	39	89 000	33 000	1 810	6 200	4 500	4,56	1316-M
	170	58	139 000	48 500	2 700	5 700	5 400	6,05	2316-K-M-C3
	170	58	139 000	48 500	2 700	5 700	5 400	6,2	2316-M
85	150	28	49 500	20 600	1 180	4 900	4 950	2,03	1217-K-TVH-C3
	150	28	49 500	20 600	1 180	4 900	4 950	2,07	1217-TVH
	150	36	59 000	23 400	1 340	7 200	5 200	2,73	2217-K-M-C3
	150	36	59 000	23 400	1 340	7 200	5 200	2,79	2217-M
	180	41	99 000	37 500	2 010	5 800	4 300	5,32	1317-K-M-C3
	180	41	99 000	37 500	2 010	5 800	4 300	5,39	1317-M
	180	60	143 000	51 000	2 750	5 400	5 200	7,04	2317-K-M-C3
	180	60	143 000	51 000	2 750	5 400	5 200	7,2	2317-M

medias ▶ <https://www.schaeffler.de/std/1D82>

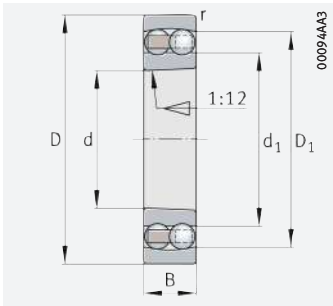

Tapered bore

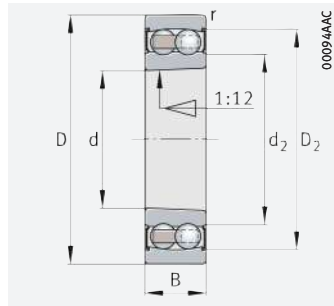

Tapered bore with seal 2RS

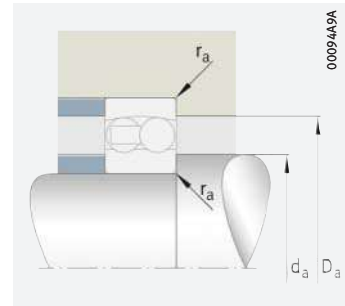

Mounting dimensions

Dimensions						Mounting dimensions			Calculation factors			
d	r	D ₁	D ₂	d ₁	d ₂	d _a	D _a	r _a	e	Y ₁	Y ₂	Y ₀
	min.	≈	≈	≈	≈	min.	max.	max.				
70	1,5	106,1	–	87,2	–	79	116	1,5	0,19	3,36	5,21	3,52
	1,5	106,1	–	87,2	–	79	116	1,5	0,19	3,36	5,21	3,52
	1,5	–	110,8	–	84,7	79	116	1,5	0,19	3,36	5,21	3,52
	1,5	108,9	–	87,6	–	79	116	1,5	0,27	2,34	3,62	2,45
	2,1	126,4	–	97,7	–	82	138	2,1	0,23	2,79	4,32	2,93
	2,1	127,2	–	91,9	–	82	138	2,1	0,38	1,65	2,55	1,73
75	1,5	113,6	–	93,7	–	84	121	1,5	0,19	3,32	5,15	3,48
	1,5	113,6	–	93,7	–	84	121	1,5	0,19	3,32	5,15	3,48
	1,5	114,3	–	93,3	–	84	121	1,5	0,26	2,47	3,82	2,59
	1,5	114,3	–	93,3	–	84	121	1,5	0,26	2,47	3,82	2,59
	2,1	134,8	–	104,8	–	87	148	2,1	0,23	2,77	4,29	2,9
	2,1	134,8	–	104,8	–	87	148	2,1	0,23	2,77	4,29	2,9
	2,1	135,2	–	100,5	–	87	148	2,1	0,38	1,64	2,54	1,72
	2,1	135,2	–	100,5	–	87	148	2,1	0,38	1,64	2,54	1,72
80	2	122,1	–	101,8	–	91	129	2	0,16	3,9	6,03	4,08
	2	122,1	–	102	–	91	129	2	0,16	3,9	6,03	4,08
	2	121	–	99,2	–	91	129	2	0,25	2,48	3,84	2,6
	2	121	–	99,2	–	91	129	2	0,25	2,48	3,84	2,6
	2,1	144,3	–	110,6	–	92	158	2,1	0,22	2,87	4,44	3
	2,1	144,3	–	110,6	–	92	158	2,1	0,22	2,87	4,44	3
	2,1	144,1	–	107,6	–	92	158	2,1	0,37	1,7	2,62	1,78
	2,1	144,1	–	107,6	–	92	158	2,1	0,37	1,7	2,62	1,78
85	2	130,4	–	107,5	–	96	139	2	0,17	3,73	5,78	3,91
	2	130,4	–	107,5	–	96	139	2	0,17	3,73	5,78	3,91
	2	130	–	105,2	–	96	139	2	0,26	2,46	3,81	2,58
	2	130	–	105,2	–	96	139	2	0,26	2,46	3,81	2,58
	3	151,9	–	117,2	–	99	166	2,5	0,22	2,88	4,46	3,02
	3	151,9	–	117,2	–	99	166	2,5	0,22	2,88	4,46	3,02
	3	152,2	–	114,4	–	99	166	2,5	0,37	1,68	2,61	1,76
	3	152,2	–	114,4	–	99	166	2,5	0,37	1,68	2,61	1,76





Self-aligning ball bearings

With cylindrical or tapered bore

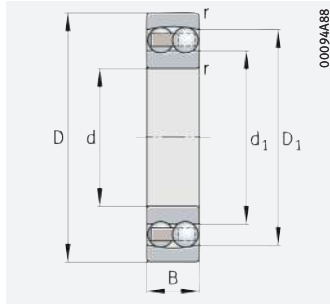

Cylindrical bore

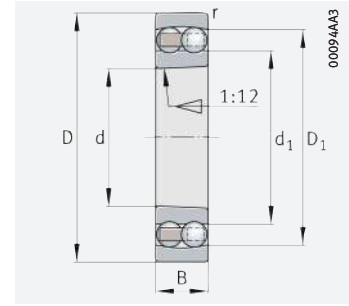

Tapered bore

d = 90 – 105 mm

Main dimensions			Basic load ratings		Fatigue limit load C_{ur} N	Limiting speed n_G min^{-1}	Speed rating $n_{\theta r}$ min^{-1}	Mass m \approx kg	Designation ➤ 377 1.12 ➤ 377 1.13
d	D	B	dyn. C_r N	stat. C_{0r} N					
90	160	30	57 000	23 300	1 300	4 550	4 850	2,48	1218-K-TVH-C3
	160	30	57 000	23 300	1 300	4 550	4 850	2,52	1218-TVH
	160	40	71 000	28 500	1 580	4 400	5 200	3,18	2218-K-TVH-C3
	160	40	71 000	28 500	1 580	4 400	5 200	3,18	2218-TVH
	190	43	109 000	42 500	2 230	5 500	4 200	6,27	1318-K-M-C3
	190	43	109 000	42 500	2 230	5 500	4 200	6,35	1318-M
	190	64	156 000	57 000	3 000	5 100	5 000	8,38	2318-K-M-C3
	190	64	156 000	57 000	3 000	5 100	5 000	8,58	2318-M
95	170	32	64 000	27 000	1 450	6 300	4 600	3,28	1219-K-M-C3
	170	32	64 000	27 000	1 450	6 300	4 600	3,32	1219-M
	170	43	84 000	34 000	1 840	6 100	5 000	4,24	2219-K-M-C3
	170	43	84 000	34 000	1 840	6 100	5 000	4,33	2219-M
	200	45	134 000	50 000	2 550	5 100	4 050	7,2	1319-K-M-C3
	200	45	134 000	50 000	2 550	5 100	4 050	7,29	1319-M
	200	67	167 000	63 000	3 250	4 800	4 750	9,97	2319-K-M-C3
	200	67	167 000	63 000	3 250	4 800	4 750	10,2	2319-M
100	180	34	70 000	29 500	1 550	6 000	4 500	3,94	1220-K-M-C3
	180	34	70 000	29 500	1 550	6 000	4 500	3,99	1220-M
	180	46	98 000	40 000	2 120	5 700	4 900	5,1	2220-K-M-C3
	180	46	98 000	40 000	2 120	5 700	4 900	5,21	2220-M
	215	47	145 000	57 000	2 800	4 700	3 850	8,95	1320-K-M-C3
	215	47	145 000	57 000	2 800	4 700	3 850	9,06	1320-M
	215	73	196 000	78 000	3 900	4 300	4 350	12,7	2320-K-M-C3
	215	73	196 000	78 000	3 900	4 300	4 350	12,9	2320-M
105	190	36	75 000	32 000	1 640	5 700	4 350	4,75	1221-M
	225	49	158 000	64 000	3 100	4 450	3 750	10,3	1321-M

medias ➤ <https://www.schaeffler.de/std/1D83>

1) The ball projection must be taken into consideration when designing the adjacent construction.

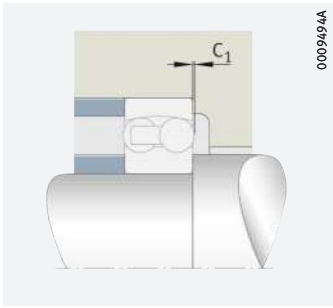

Ball projection C_1

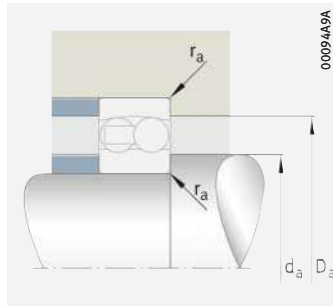

Mounting dimensions

Dimensions					Mounting dimensions			Calculation factors			
d	r	D ₁	d ₁	C ₁ ¹⁾	d _a	D _a	r _a	e	Y ₁	Y ₂	Y ₀
	min.	≈	≈	≈	min.	max.	max.				
90	2	138,7	112,7	–	101	149	2	0,17	3,74	5,79	3,92
	2	138,7	112,7	–	101	149	2	0,17	3,74	5,79	3,92
	2	139,4	111,5	–	101	149	2	0,27	2,33	3,61	2,44
	2	139,4	111,5	–	101	149	2	0,27	2,33	3,61	2,44
	3	159,8	124,4	–	104	176	2,5	0,22	2,83	4,38	2,97
	3	159,8	124,4	–	104	176	2,5	0,22	2,83	4,38	2,97
	3	159,8	115,7	–	104	176	2,5	0,39	1,63	2,53	1,71
	3	159,8	115,7	–	104	176	2,5	0,39	1,63	2,53	1,71
95	2,1	148,2	120,5	–	107	158	2,1	0,17	3,73	5,78	3,91
	2,1	148,2	120,5	–	107	158	2,1	0,17	3,73	5,78	3,91
	2,1	147,9	118,9	–	107	158	2,1	0,27	2,32	3,59	2,43
	2,1	147,9	118,9	–	107	158	2,1	0,27	2,32	3,59	2,43
	3	169,9	127,6	1,6	109	186	2,5	0,23	2,73	4,23	2,86
	3	169,9	127,6	1,6	109	186	2,5	0,23	2,73	4,23	2,86
	3	167,7	121,6	–	109	186	2,5	0,38	1,66	2,57	1,74
	3	167,7	121,6	–	109	186	2,5	0,38	1,66	2,57	1,74
100	2,1	155,2	127,3	–	112	168	2,1	0,18	3,58	5,53	3,75
	2,1	155,2	127,3	–	112	168	2,1	0,18	3,58	5,53	3,75
	2,1	156,9	124,4	–	112	168	2,1	0,27	2,33	3,61	2,44
	2,1	156,9	124,4	–	112	168	2,1	0,27	2,33	3,61	2,44
	3	181,3	135,9	2,4	114	201	2,5	0,24	2,68	4,15	2,81
	3	181,3	135,9	2,4	114	201	2,5	0,24	2,68	4,15	2,81
	3	182,7	130,8	–	114	201	2,5	0,38	1,67	2,58	1,75
	3	182,7	130,8	–	114	201	2,5	0,38	1,67	2,58	1,75
105	2,1	155,2	133,9	–	117	178	2,1	0,18	3,54	5,48	3,71
	3	190,5	143,2	2,5	119	211	2,5	0,23	2,75	4,25	2,88





Self-aligning ball bearings

With cylindrical or tapered bore

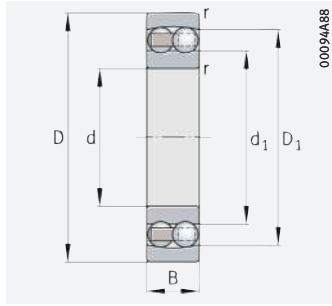

Cylindrical bore

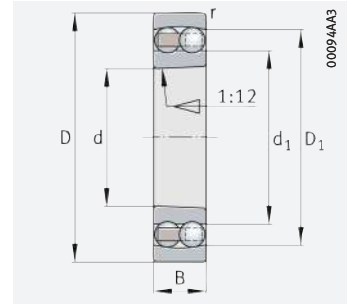

Tapered bore

d = 110 – 150 mm

Main dimensions			Basic load ratings		Fatigue limit load	Limiting speed	Speed rating	Mass	Designation
d	D	B	dyn. C_r N	stat. C_{0r} N	C_{ur} N	n_G min^{-1}	$n_{\partial r}$ min^{-1}	m \approx kg	▶ 377 1.12 ▶ 377 1.13
110	200	38	89 000	38 000	1 900	5 300	4 250	5,49	1222-K-M-C3
	200	38	89 000	38 000	1 900	5 300	4 250	5,57	1222-M
	200	53	126 000	51 000	2 550	5 000	4 700	7,27	2222-K-M-C3
	200	53	126 000	51 000	2 550	5 000	4 700	7,45	2222-M
	240	50	165 000	71 000	3 300	4 200	3 400	12,2	1322-K-M-C3
	240	50	165 000	71 000	3 300	4 200	3 400	12,3	1322-M
	240	80	221 000	94 000	4 400	3 850	3 900	17,5	2322-K-M-C3
	240	80	221 000	94 000	4 400	3 850	3 900	18,1	2322-M
120	215	42	121 000	52 000	2 500	4 750	4 200	7,13	1224-M
130	230	46	125 000	55 000	2 550	4 450	4 000	8,67	1226-M
140	250	50	163 000	74 000	3 300	3 900	3 650	11,2	1228-M
150	270	54	180 000	86 000	3 700	3 600	3 400	14,6	1230-M

medias ▶ <https://www.schaeffler.de/std/1D84>

1) The ball projection must be taken into consideration when designing the adjacent construction.

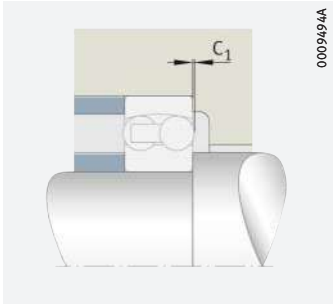

0009494A

Ball projection C_1

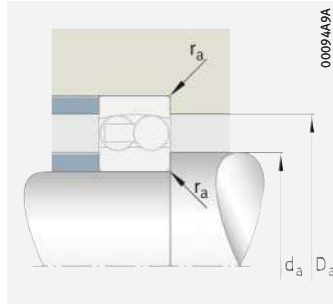

0009494A

Mounting dimensions

Dimensions					Mounting dimensions			Calculation factors			
d	r	D ₁	d ₁	C ₁ ¹⁾	d _a	D _a	r _a	e	Y ₁	Y ₂	Y ₀
	min.	≈	≈	≈	min.	max.	max.				
110	2,1	173,2	140,2	–	122	188	2,1	0,17	3,61	5,59	3,78
	2,1	173,2	140,2	–	122	188	2,1	0,17	3,61	5,59	3,78
	2,1	174,1	136,9	–	122	188	2,1	0,28	2,23	3,45	2,33
	2,1	174,1	136,9	–	122	188	2,1	0,28	2,23	3,45	2,33
	3	202,5	154,5	2,7	124	226	2,5	0,23	2,79	4,32	2,92
	3	202,5	154,5	2,7	124	226	2,5	0,23	2,79	4,32	2,92
	3	201,8	145,5	–	124	226	2,5	0,37	1,69	2,62	1,77
	3	201,8	145,5	–	124	226	2,5	0,37	1,69	2,62	1,77
120	2,1	187,3	149	1,8	132	203	2,1	0,2	3,11	4,81	3,25
130	3	200	161,5	0,6	144	216	2,5	0,19	3,24	5,02	3,4
140	3	220,5	175	2,7	154	236	2,5	0,21	3,05	4,71	3,19
150	3	237,9	186,7	3,8	164	256	2,5	0,22	2,9	4,49	3,04





Self-aligning ball bearings

With extended inner ring

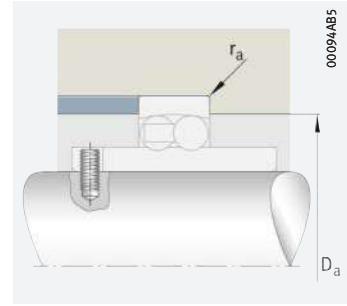
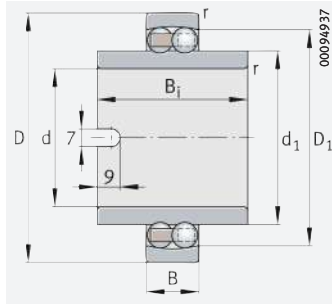

Mounting dimensions

d = 20 – 60 mm

Main dimensions			Basic load ratings		Fatigue limit load	Limiting speed	Mass	Designation
d	D	B	dyn. C _r N	stat. C _{0r} N	C _{ur} N	n _G min ⁻¹	m ≈ kg	▶ 377 1.12 ▶ 377 1.13
20	47	14	10 100	2 600	161	18 100	0,186	11204-TVH
25	52	15	12 300	3 250	203	15 500	0,22	11205-TVH
30	62	16	15 900	4 600	285	13 100	0,35	11206-TVH
35	72	17	16 000	5 100	315	11 600	0,54	11207-TVH
40	80	18	19 400	6 500	400	10 100	0,72	11208-TVH
45	85	19	22 000	7 300	455	9 300	0,77	11209-TVH
50	90	20	22 900	8 000	500	8 700	0,85	11210-TVH
55	100	21	27 000	9 900	620	7 700	1,17	11211-TVH
60	110	22	30 500	11 400	710	6 900	1,5	11212-TVH

medias ▶ <https://www.schaeffler.de/std/1D85>



Dimensions					Mounting dimensions		Calculation factors			
d	r min.	B _i ≈	D ₁ ≈	d ₁ ≈	D _a max.	r _a max.	e	Y ₁	Y ₂	Y ₀
20	1	40	37,8	29,2	41,4	1	0,28	2,24	3,46	2,34
25	1	44	43,6	33,3	46,4	1	0,27	2,37	3,66	2,48
30	1	48	51,6	40,1	56,4	1	0,25	2,53	3,91	2,65
35	1,1	52	59,1	47,7	65	1	0,22	2,8	4,34	2,94
40	1,1	56	67,3	54	73	1	0,22	2,9	4,49	3,04
45	1,1	58	72,1	57,7	78	1	0,21	3,04	4,7	3,18
50	1,1	58	77,1	62,7	83	1	0,2	3,17	4,9	3,32
55	1,5	60	86,4	69,5	91	1,5	0,19	3,31	5,12	3,47
60	1,5	62	95,2	78	101	1,5	0,18	3,47	5,37	3,64

Self-aligning ball bearings

With adapter sleeve

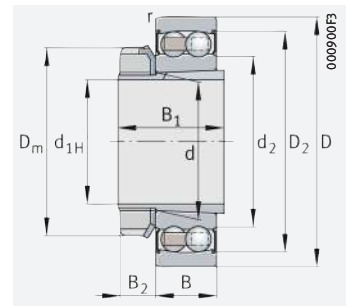
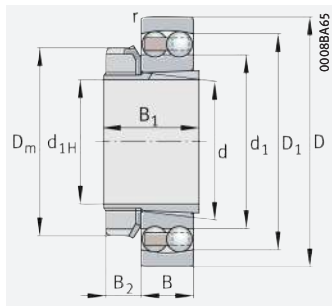

With seal 2RS

d_{1H} = 17 – 45 mm

Main dimensions				Basic load ratings		Fatigue limit load C _{ur} N	Limiting speed n _G min ⁻¹	Speed rating n _{0r} min ⁻¹	Mass m		Designation	
d _{1H}	d	D	B	dyn. C _r N	stat. C _{0r} N				Bearing ≈ kg	Adapter sleeve ≈ kg	Bearing	Adapter sleeve
17	20	47	14	10 100	2 600	161	18 100	15 300	0,116	0,04	1204-K-TVH-C3	H204
20	25	52	15	12 300	3 250	203	15 500	13 400	0,135	0,07	1205-K-TVH-C3	H205
	25	52	18	12 300	3 250	203	8 100	–	0,157	0,07	2205-K-2RS-TVH-C3	H305
	25	52	18	17 300	4 400	275	14 400	13 400	0,152	0,07	2205-K-TVH-C3	H305
	25	62	17	18 300	4 950	310	12 900	10 000	0,254	0,07	1305-K-TVH-C3	H305
	25	62	24	25 000	6 500	405	12 200	11 900	0,328	0,09	2305-K-TVH-C3	H2305
25	30	62	16	15 900	4 600	285	13 100	11 400	0,217	0,1	1206-K-TVH-C3	H206
	30	62	20	15 900	4 600	285	6 800	–	0,268	0,11	2206-K-2RS-TVH-C3	H306
	30	62	20	26 000	6 900	425	11 500	11 400	0,246	0,11	2206-K-TVH-C3	H306
	30	72	19	21 700	6 300	390	11 100	8 700	0,379	0,11	1306-K-TVH-C3	H306
	30	72	27	32 500	8 700	540	10 200	10 400	0,476	0,13	2306-K-TVH-C3	H2306
30	35	72	17	16 000	5 100	315	11 600	9 800	0,319	0,136	1207-K-TVH-C3	H207
	35	72	23	16 000	5 100	315	5 600	–	0,432	0,153	2207-K-2RS-TVH-C3	H307
	35	72	23	33 000	8 900	560	9 800	10 300	0,38	0,153	2207-K-TVH-C3	H307
	35	80	21	25 500	7 800	485	9 700	7 800	0,5	0,153	1307-K-TVH-C3	H307
	35	80	31	40 500	11 100	690	8 900	9 800	0,657	0,16	2307-K-TVH-C3	H2307
35	40	80	18	19 400	6 500	400	10 100	8 600	0,408	0,177	1208-K-TVH-C3	H208
	40	80	23	19 400	6 500	400	4 950	–	0,517	0,192	2208-K-2RS-TVH-C3	H308
	40	80	23	32 500	9 400	580	8 900	8 700	0,465	0,192	2208-K-TVH-C3	H308
	40	90	23	30 000	9 600	600	8 600	7 200	0,698	0,192	1308-K-TVH-C3	H308
	40	90	33	46 000	13 400	830	7 900	8 700	0,899	0,23	2308-K-TVH-C3	H2308
40	45	85	19	22 000	7 300	455	9 300	8 200	0,454	0,23	1209-K-TVH-C3	H209
	45	85	23	22 000	7 300	455	4 650	–	0,535	0,253	2209-K-2RS-TVH-C3	H309
	45	85	23	28 500	8 900	550	8 600	7 800	0,505	0,253	2209-K-TVH-C3	H309
	45	100	25	38 500	12 600	780	7 500	6 700	0,939	0,253	1309-K-TVH-C3	H309
	45	100	36	55 000	16 500	1 030	7 000	8 000	1,19	0,298	2309-K-TVH-C3	H2309
45	50	90	20	22 900	8 000	500	8 700	7 700	0,516	0,276	1210-K-TVH-C3	H210
	50	90	23	22 900	8 000	500	4 250	–	0,593	0,306	2210-K-2RS-TVH-C3	H310
	50	90	23	28 500	9 400	580	8 100	7 100	0,543	0,306	2210-K-TVH-C3	H310
	50	110	27	42 000	14 100	880	6 900	6 300	1,19	0,306	1310-K-TVH-C3	H310

medias ► <https://www.schaeffler.de/std/1D86>

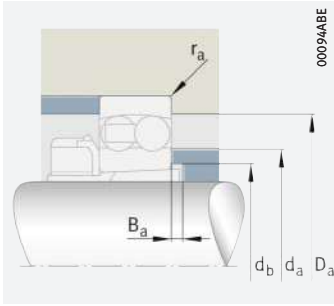

Mounting dimensions

Dimensions									Mounting dimensions					Calculation factors			
d_{1H}	r	D_1	D_2	d_1	d_2	D_m	B_1	B_2	d_a	D_a	d_b	B_a	r_a	e	Y_1	Y_2	Y_0
	min.	≈	≈	≈	≈			≈	max.	max.	min.	min.	max.				
17	1	37,8	-	29,2	-	32	24	7	27	41,4	23	5	1	0,28	2,24	3,46	2,34
20	1	43,6	-	33,3	-	38	26	8,25	32	46,4	28	5	1	0,27	2,37	3,66	2,48
	1	-	45,3	-	30,7	38	29	8,25	32	46,4	28	5	1	0,27	2,37	3,66	2,48
	1	44,4	-	32,3	-	38	29	8,25	32	46,4	28	5	1	0,35	1,78	2,75	1,86
	1,1	50,4	-	38,1	-	38	29	8,25	35	55	28	6	1	0,28	2,29	3,54	2,4
	1,1	49,9	-	35,5	-	38	35	8,25	34	55	30	5	1	0,48	1,32	2,04	1,38
	1,1	58,8	-	41,5	-	45	38	8,25	40	65	35	5	1	0,45	1,4	2,17	1,47
25	1	51,6	-	40,1	-	45	27	8,25	38	56,4	33	5	1	0,25	2,53	3,91	2,65
	1	-	53,3	-	37,3	45	31	8,25	38	56,4	33	5	1	0,25	2,53	3,91	2,65
	1	53,7	-	38,5	-	45	31	8,25	38	56,4	33	5	1	0,3	2,13	3,29	2,23
	1,1	58,9	-	45,1	-	45	31	8,25	42	65	33	6	1	0,26	2,39	3,71	2,51
	1,1	58,8	-	41,5	-	45	38	8,25	40	65	35	5	1	0,45	1,4	2,17	1,47
30	1,1	59,1	-	47,7	-	52	29	9,25	45	65	38	5	1	0,22	2,8	4,34	2,94
	1,1	-	63,4	-	43,5	52	35	9,25	45	65	38	5	1	0,22	2,8	4,34	2,94
	1,1	62,4	-	45,7	-	52	35	9,25	44	65	39	5	1	0,3	2,13	3,29	2,23
	1,5	70,1	-	51,3	-	52	35	9,25	49	71	39	8	1,5	0,26	2,47	3,82	2,59
	1,5	66,1	-	46,9	-	52	43	9,25	45	71	40	5	1,5	0,47	1,35	2,1	1,42
	1,5	74,5	-	53,7	-	58	46	10,25	51	81	45	5	1,5	0,43	1,45	2,25	1,52
35	1,1	67,3	-	54	-	58	31	10,25	52	73	43	5	1	0,22	2,9	4,49	3,04
	1,1	-	70,3	-	49,2	58	36	10,25	52	73	43	5	1	0,22	2,9	4,49	3,04
	1,1	70,2	-	52,5	-	58	36	10,25	50	73	44	5	1	0,26	2,43	3,76	2,54
	1,5	74,7	-	57,8	-	58	36	10,25	55	81	44	5	1,5	0,25	2,52	3,9	2,64
	1,5	74,5	-	53,7	-	58	46	10,25	51	81	45	5	1,5	0,43	1,45	2,25	1,52
40	1,1	72,1	-	57,7	-	65	33	11,25	57	78	48	5	1	0,21	3,04	4,7	3,18
	1,1	-	76	-	53,8	65	39	11,25	57	78	48	5	1	0,21	3,04	4,7	3,18
	1,1	75,4	-	59	-	65	39	11,25	56	78	50	8	1	0,26	2,43	3,76	2,54
	1,5	83,5	-	64,1	-	65	39	11,25	61	91	50	5	1,5	0,25	2,5	3,87	2,62
	1,5	83,6	-	60,1	-	65	50	11,25	57	91	50	5	1,5	0,43	1,48	2,29	1,55
45	1,1	77,1	-	62,7	-	70	35	12,25	62	83	53	5	1	0,2	3,17	4,9	3,32
	1,1	-	79	-	60,5	70	42	12,25	62	83	53	5	1	0,2	3,17	4,9	3,32
	1,1	80,5	-	64	-	70	42	12,25	61	83	55	10	1	0,24	2,61	4,05	2,74
	2	91,7	-	71,2	-	70	42	12,25	68	99	55	5	2	0,24	2,6	4,03	2,73



Self-aligning ball bearings

With adapter sleeve

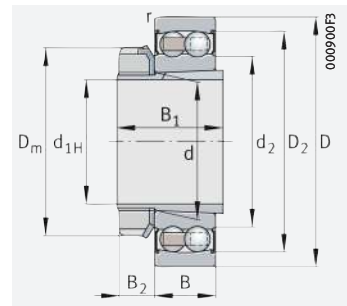
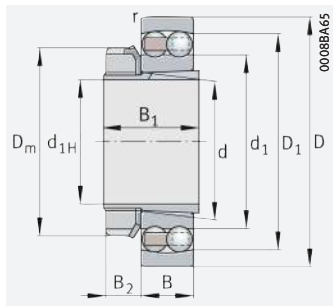

With seal 2RS

$d_{1H} = 50 - 75 \text{ mm}$

Main dimensions				Basic load ratings		Fatigue limit load	Limiting speed	Speed rating	Mass m		Designation	
d_{1H}	d	D	B	dyn. C_r	stat. C_{0r}	C_{ur}	n_G	$n_{\theta r}$	Bearing	Adapter sleeve	Bearing	Adapter sleeve
				N	N	N	min^{-1}	min^{-1}	≈ kg	≈ kg	▶ 377 1.12 ▶ 377 1.13	
50	55	100	21	27 000	9 900	620	7 700	6 900	0,682	0,319	1211-K-TVH-C3	H211
	55	100	25	27 000	9 900	620	3 850	–	0,808	0,358	2211-K-2RS-TVH-C3	H311
	55	100	25	39 000	12 400	770	7 000	6 700	0,73	0,358	2211-K-TVH-C3	H311
	55	120	29	52 000	17 700	1 100	6 100	5 800	1,55	0,358	1311-K-TVH-C3	H311
	55	120	43	77 000	23 800	1 480	5 700	7 100	2,02	0,435	2311-K-TVH-C3	H2311
55	60	110	22	30 500	11 400	710	6 900	6 300	0,88	0,35	1212-K-TVH-C3	H212
	60	110	28	30 500	11 400	710	3 450	–	1,13	0,401	2212-K-2RS-TVH-C3	H312
	60	110	28	48 000	16 300	1 020	6 300	6 400	1,03	0,401	2212-K-TVH-C3	H312
	60	130	31	58 000	20 600	1 280	5 500	5 200	1,94	0,401	1312-K-TVH-C3	H312
	60	130	46	89 000	28 000	1 740	5 200	6 700	2,52	0,493	2312-K-TVH-C3	H2312
60	65	120	23	31 000	12 400	770	6 500	5 800	1,13	0,4	1213-K-TVH-C3	H213
	65	120	31	31 000	12 400	770	3 150	–	1,5	0,471	2213-K-2RS-TVH-C3	H313
	65	120	31	58 000	19 000	1 190	5 600	6 200	1,33	0,471	2213-K-TVH-C3	H313
	65	140	33	63 000	22 700	1 380	5 200	5 100	2,41	0,471	1313-K-TVH-C3	H313
	65	140	48	98 000	32 000	1 980	4 750	6 100	3,16	0,57	2313-K-TVH-C3	H2313
	70	125	24	35 000	13 700	850	6 200	5 900	1,23	0,63	1214-K-TVH-C3	H214
65	75	130	25	39 000	15 600	950	5 700	5 500	1,32	0,71	1215-K-TVH-C3	H215
	75	130	31	44 500	17 600	1 080	5 600	5 600	1,6	0,86	2215-K-TVH-C3	H315
	75	160	37	80 000	29 500	1 690	6 700	4 750	3,52	1,06	1315-K-M-C3	H315
	75	160	55	125 000	42 000	2 420	6 100	5 600	5,21	0,89	2315-K-M-C3	H2315
70	80	140	26	40 000	16 800	990	5 300	5 100	1,62	0,89	1216-K-TVH-C3	H216
	80	140	33	49 500	19 800	1 180	5 300	5 400	1,97	1,06	2216-K-TVH-C3	H316
	80	170	39	89 000	33 000	1 810	6 200	4 500	4,5	1,06	1316-K-M-C3	H316
	80	170	58	139 000	48 500	2 700	5 700	5 400	6,05	1,31	2316-K-M-C3	H2316
75	85	150	28	49 500	20 600	1 180	4 900	4 950	2,03	1,03	1217-K-TVH-C3	H217
	85	150	36	59 000	23 400	1 340	7 200	5 200	2,73	1,21	2217-K-M-C3	H317
	85	180	41	99 000	37 500	2 010	5 800	4 300	5,32	1,21	1317-K-M-C3	H317
	85	180	60	143 000	51 000	2 750	5 400	5 200	7,04	1,47	2317-K-M-C3	H2317

medias ▶ <https://www.schaeffler.de/std/1D87>

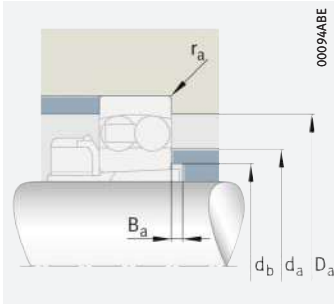

Mounting dimensions

Dimensions									Mounting dimensions					Calculation factors			
d_{1H}	r	D_1	D_2	d_1	d_2	D_m	B_1	B_2	d_a	D_a	d_b	B_a	r_a	e	Y_1	Y_2	Y_0
		min.	≈	≈	≈				≈	max.	max.	min.	min.				
50	1,5	86,4	-	69,5	-	75	37	12,5	69	91	60	6	1,5	0,19	3,31	5,12	3,47
	1,5	-	88,2	-	68	75	45	12,5	69	91	60	6	1,5	0,19	3,31	5,12	3,47
	1,5	89,8	-	69,6	-	75	45	12,5	68	91	60	10	1,5	0,22	2,92	4,52	3,06
	2	101	-	78	-	75	45	12,5	74	109	60	6	2	0,24	2,66	4,12	2,79
	2	100,2	-	71,7	-	75	59	12,5	69	109	61	6	2	0,42	1,51	2,33	1,58
55	1,5	95,2	-	78	-	80	38	12,5	75	101	64	5	1,5	0,18	3,47	5,37	3,64
	1,5	-	99,5	-	70,4	80	47	12,5	75	101	64	5	1,5	0,18	3,47	5,37	3,64
	1,5	98,2	-	76,6	-	80	47	12,5	73	101	65	8	1,5	0,23	2,69	4,16	2,82
	2,1	112,2	-	87	-	80	47	12,5	83	118	65	5	2,1	0,23	2,77	4,28	2,9
	2,1	108,5	-	77	-	80	62	12,5	74	118	66	5	2,1	0,41	1,55	2,4	1,62
60	1,5	102,7	-	85,2	-	85	40	13,5	83	111	70	5	1,5	0,18	3,57	5,52	3,74
	1,5	-	107,8	-	78	85	50	13,5	83	111	70	5	1,5	0,18	3,57	5,52	3,74
	1,5	106,9	-	82,4	-	85	50	13,5	79	111	70	8	1,5	0,23	2,78	4,31	2,92
	2,1	118,2	-	92,7	-	85	50	13,5	89	128	70	5	2,1	0,23	2,75	4,26	2,88
	2,1	118,3	-	85,6	-	85	65	13,5	82	128	72	5	2,1	0,39	1,62	2,51	1,7
	1,5	106,1	-	87,2	-	92	41	13,5	86	116	75	5	1,5	0,19	3,36	5,21	3,52
65	1,5	113,6	-	93,7	-	98	43	14,5	92	121	80	5	1,5	0,19	3,32	5,15	3,48
	1,5	114,3	-	93,3	-	98	55	14,5	90	121	80	12	1,5	0,26	2,47	3,82	2,59
	2,1	134,8	-	104,8	-	98	55	14,5	100	148	80	5	2,1	0,23	2,77	4,29	2,9
	2,1	135,2	-	100,5	-	98	73	14,5	94	148	82	5	2,1	0,38	1,64	2,54	1,72
70	2	122,1	-	101,8	-	105	46	16,75	99	129	85	5	2	0,16	3,9	6,03	4,08
	2	121	-	99,2	-	105	59	16,75	96	129	85	12	2	0,25	2,48	3,84	2,6
	2,1	144,3	-	110,6	-	105	59	16,75	107	158	85	5	2,1	0,22	2,87	4,44	3
	2,1	144,1	-	107,6	-	105	78	16,75	100	158	88	5	2,1	0,37	1,7	2,62	1,78
75	2	130,4	-	107,5	-	110	50	17,75	105	139	90	6	2	0,17	3,73	5,78	3,91
	2	130	-	105,2	-	110	63	17,75	102	139	91	12	2	0,26	2,46	3,81	2,58
	3	151,9	-	117,2	-	110	63	17,75	114	166	91	6	2,5	0,22	2,88	4,46	3,02
	3	152,2	-	114,4	-	110	82	17,75	106	166	94	6	2,5	0,37	1,68	2,61	1,76





Self-aligning ball bearings

With adapter sleeve

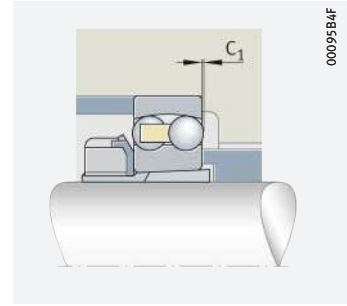
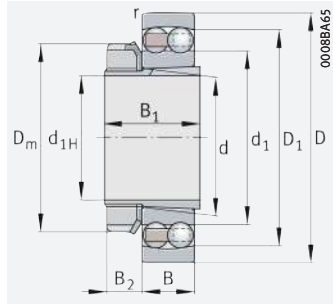

Ball projection C_1 ¹⁾

$d_{1H} = 80 - 100 \text{ mm}$

Main dimensions				Basic load ratings		Fatigue limit load C_{ur} N	Limiting speed n_G min^{-1}	Speed rating $n_{\theta r}$ min^{-1}	Mass m		Designation	
d_{1H}	d	D	B	dyn. C_r N	stat. C_{0r} N				Bearing $\approx \text{kg}$	Adapter sleeve $\approx \text{kg}$	Bearing	Adapter sleeve
80	90	160	30	57 000	23 300	1 300	4 550	4 850	2,48	1,21	1218-K-TVH-C3	H218
	90	160	40	71 000	28 500	1 580	4 400	5 200	3,18	1,41	2218-K-TVH-C3	H318
	90	190	43	109 000	42 500	2 230	5 500	4 200	6,27	1,41	1318-K-M-C3	H318
	90	190	64	156 000	57 000	3 000	5 100	5 000	8,38	1,71	2318-K-M-C3	H2318
85	95	170	32	64 000	27 000	1 450	6 300	4 600	3,28	1,39	1219-K-M-C3	H219
	95	170	43	84 000	34 000	1 840	6 100	5 000	4,24	1,58	2219-K-M-C3	H319
	95	200	45	134 000	50 000	2 550	5 100	4 050	7,2	1,58	1319-K-M-C3	H319
	95	200	67	167 000	63 000	3 250	4 800	4 750	9,97	1,95	2319-K-M-C3	H2319
90	100	180	34	70 000	29 500	1 550	6 000	4 500	3,94	1,52	1220-K-M-C3	H220
	100	180	46	98 000	40 000	2 120	5 700	4 900	5,1	1,76	2220-K-M-C3	H320
	100	215	47	145 000	57 000	2 800	4 700	3 850	8,95	1,76	1320-K-M-C3	H320
	100	215	73	196 000	78 000	3 900	4 300	4 350	12,7	2,2	2320-K-M-C3	H2320
100	110	200	38	89 000	38 000	1 900	5 300	4 250	5,49	1,95	1222-K-M-C3	H222
	110	200	53	126 000	51 000	2 550	5 000	4 700	7,27	2,25	2222-K-M-C3	H322
	110	240	50	165 000	71 000	3 300	4 200	3 400	12,2	2,25	1322-K-M-C3	H322
	110	240	80	221 000	94 000	4 400	3 850	3 900	17,5	2,78	2322-K-M-C3	H2322

medias ► <https://www.schaeffler.de/std/1DCB>

¹⁾ The ball projection must be taken into consideration when designing the adjacent construction.

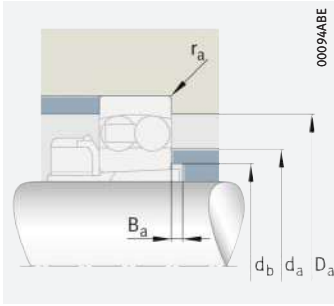

Mounting dimensions

Dimensions								Mounting dimensions					Calculation factors			
d_{1H}	r	D_1	d_1	D_m	B_1	B_2	$C_1^{1)}$	d_a	D_a	d_b	B_a	r_a	e	Y_1	Y_2	Y_0
	min.	≈	≈			≈		max.	max.	min.	min.	max.				
80	2	138,7	112,7	120	52	17,75	-	110	149	95	6	2	0,17	3,74	5,79	3,92
	2	139,4	111,5	120	65	17,75	-	108	149	96	10	2	0,27	2,33	3,61	2,44
	3	159,8	124,4	120	65	17,75	-	120	176	96	6	2,5	0,22	2,83	4,38	2,97
	3	159,8	115,7	120	86	17,75	-	112	176	100	6	2,5	0,39	1,63	2,53	1,71
85	2,1	148,2	120,5	125	55	18,75	-	117	158	100	7	2,1	0,17	3,73	5,78	3,91
	2,1	147,9	118,9	125	68	18,75	-	114	158	102	9	2,1	0,27	2,32	3,59	2,43
	3	169,9	127,6	125	68	18,75	1,6	126	186	102	7	2,5	0,23	2,73	4,23	2,86
	3	167,7	121,6	125	90	18,75	-	117	186	105	7	2,5	0,38	1,66	2,57	1,74
90	2,1	155,2	127,3	130	58	19,75	-	124	168	106	7	2,1	0,18	3,58	5,53	3,75
	2,1	156,9	124,4	130	71	19,75	-	120	168	108	8	2,1	0,27	2,33	3,61	2,44
	3	181,3	135,9	130	71	19,75	2,4	132	201	108	7	2,5	0,24	2,68	4,15	2,81
	3	182,7	130,8	130	97	19,75	-	125	201	110	7	2,5	0,38	1,67	2,58	1,75
100	2,1	173,2	140,2	145	63	20,75	-	138	188	116	7	2,1	0,17	3,61	5,59	3,78
	2,1	174,1	136,9	145	77	20,75	-	132	188	118	6	2,1	0,28	2,23	3,45	2,33
	3	202,5	154,5	145	77	20,75	2,7	150	226	118	9	2,5	0,23	2,79	4,32	2,92
	3	201,8	145,5	145	105	20,75	-	139	226	121	7	2,5	0,37	1,69	2,62	1,77



Cylindrical roller bearings



Matrix for bearing preselection 410

1 Single row cylindrical roller bearings with cage **412**

1.1	Bearing design	412
1.2	Load carrying capacity	417
1.3	Compensation of angular misalignments	420
1.4	Lubrication	420
1.5	Sealing	420
1.6	Speeds	420
1.7	Noise	421
1.8	Temperature range	422
1.9	Cages	422
1.10	Internal clearance	424
1.11	Dimensions, tolerances	425
1.12	Suffixes	425
1.13	Structure of bearing designation	426
1.14	Dimensioning	426
1.15	Minimum load	427
1.16	Design of bearing arrangements	428



1.17	Mounting and dismantling	431
1.18	Legal notice regarding data freshness	431
1.19	Further information	432
	Product tables	434
	<i>Cylindrical roller bearings with cage, non-locating bearings</i>	434
	<i>Cylindrical roller bearings with cage, semi-locating bearings, locating bearings</i>	450

2 Cylindrical roller bearings with disc cage or with spacers **478**

2.1	Bearing design	478
2.2	Load carrying capacity	480
2.3	Compensation of angular misalignments	483
2.4	Lubrication	484
2.5	Sealing	484
2.6	Speeds	484
2.7	Noise	485
2.8	Temperature range	486
2.9	Cages	486
2.10	Internal clearance	487
2.11	Dimensions, tolerances	488
2.12	Suffixes	488
2.13	Structure of bearing designation	488
2.14	Dimensioning	489
2.15	Minimum load	490
2.16	Design of bearing arrangements	490
2.17	Mounting and dismantling	492
2.18	Legal notice regarding data freshness	493
2.19	Further information	493
	Product tables	494
	<i>Cylindrical roller bearings with disc cage, semi-locating bearings</i>	494
	<i>Cylindrical roller bearings with spacers, semi-locating bearings</i>	496

3 Single row full complement cylindrical roller bearings **498**

3.1	Bearing design	498
3.2	Load carrying capacity	501
3.3	Compensation of angular misalignments	503
3.4	Lubrication	504
3.5	Sealing	504
3.6	Speeds	504

3.7	Noise	504
3.8	Temperature range	505
3.9	Cages	505
3.10	Internal clearance	506
3.11	Dimensions, tolerances	506
3.12	Suffixes	507
3.13	Structure of bearing designation	507
3.14	Dimensioning	507
3.15	Minimum load	508
3.16	Design of bearing arrangements	508
3.17	Mounting and dismantling	511
3.18	Legal notice regarding data freshness	511
3.19	Further information	512
	Product table	514
	<i>Single row full complement cylindrical roller bearings</i>	514

4 Double row full complement cylindrical roller bearings **524**

4.1	Bearing design	524
4.2	Load carrying capacity	528
4.3	Compensation of angular misalignments	530
4.4	Lubrication	530
4.5	Sealing	531
4.6	Speeds	531
4.7	Noise	531
4.8	Temperature range	532
4.9	Cages	532
4.10	Internal clearance	533
4.11	Dimensions, tolerances	534
4.12	Suffixes	534
4.13	Structure of bearing designation	535
4.14	Dimensioning	535
4.15	Minimum load	536
4.16	Design of bearing arrangements	537
4.17	Mounting and dismantling	540
4.18	Legal notice regarding data freshness	541
4.19	Further information	541
	Product tables	542
	<i>Double row full complement cylindrical roller bearings</i>	542
	<i>Double row full complement cylindrical roller bearings with annular slots</i>	550





Matrix for bearing preselection

The matrix gives an overview of the types and design features of cylindrical roller bearings.

































It can be used to make a preliminary assessment of whether a bearing is fundamentally suitable for the envisaged application.

The additional information provided in the product chapter (see column "detailed information") and in the Technical principles must, however, be observed in addition to this overview in selection of the bearing.

Design features and suitability			Cylindrical roller bearings with cage, single row			
+++ extremely suitable ++ highly suitable + suitable (+) suitable with restrictions - not suitable/not applicable ✓ available			non-locating bearing 	semi-locating bearing 	locating bearing 	detailed information 350
Load carrying capacity	radial		+++	+++	+++	➤ 352 1.2
	axial, one direction		-	+	+	➤ 352 1.2
	axial, both directions		-	-	+	➤ 352 1.2
	moments		-	-	-	➤ 352 1.2
Compensation of angular misalignments	static		(+)	(+)	(+)	➤ 352 1.3
	dynamic		(+)	(+)	(+)	➤ 352 1.3
Bearing design	cylindrical bore		✓	✓	✓	➤ 350 1.1
	tapered bore		-	-	-	
	separable		✓	✓	✓	➤ 360 1.17
Lubrication	greased		-	-	-	➤ 353 1.4
Sealing	open		✓	✓	✓	➤ 353 1.5
	non-contact		-	-	-	➤ 353 1.5
	contact		-	-	-	➤ 353 1.5
Operating temperature in °C	from to		-30 +150 ³⁾	-30 +150 ³⁾	-30 +150 ³⁾	➤ 354 1.8
Suitability for	high speeds		++	++ ⁵⁾	++ ⁵⁾	➤ 353 1.6 ➤ 24
	high running accuracy		++	++	++	➤ 356 1.11 ➤ 114
	low-noise running		+	(+)	(+)	➤ 421 1.7 ➤ 27
	high rigidity		++	++	++	➤ 54
	reduced friction		++	++	++	➤ 56
	length compensation within bearing		+++	(+)	-	➤ 413 ➤ 25
	non-locating bearing arrangement		+++	+	-	➤ 139
	locating bearing arrangement		-	+	++	➤ 139
X-life bearings			✓	✓	✓	➤ 351
Bearing bore d in mm	from to		15 710 ⁸⁾	15 280 ⁸⁾	15 280 ⁸⁾	➤ 362
Product tables	from page		362	450	450	

1) Valid only for series SL1923
 2) Valid only for non-locating bearings SL0248 and SL0249
 3) Valid for bearings with sheet steel cage or brass cage
 4) With greasing using GA22
 5) For low axial load only
 6) Valid for locating bearings SL0148 and SL0149
 7) Only semi-locating bearings SL1850
 8) Larger catalogue bearings
 ➤ GL 1



Cylindrical roller bearings with disc cage or spacers			Single row full complement cylindrical roller bearings		Double row full complement cylindrical roller bearings			
with disc cage 	with spacers 	detailed information  478	semi-locating bearing 	detailed information  498	locating/semi-locating/non-locating bearing 	locating bearing with annular slots 	detailed information  524	
+++	+++	➤480 2.2	+++	➤501 3.2	+++	+++	➤528 4.2	
+	+	➤480 2.2	+	➤501 3.2	(+)	(+)	➤528 4.2	
-	-	➤480 2.2	-	➤501 3.2	(+)	(+)	➤528 4.2	
-	-	➤480 2.2	-	➤501 3.2	+	+	➤528 4.2	
(+)	(+)	➤483 2.3	(+)	➤503 3.3	-	-	➤530 4.3	
(+)	(+)	➤483 2.3	(+)	➤503 3.3	-	-	➤530 4.3	
✓	✓	➤478 2.1	✓	➤503 3.3	✓	✓	➤530 4.3	
-	-		-		-	-		
✓	✓	➤492 2.17	✓ ¹⁾	➤511 3.17	✓ ²⁾	-	➤540 4.17	
-	-	➤484 2.4	-	➤504 3.4	-	✓	➤530 4.4	
✓	✓	➤484 2.5	✓	➤504 3.5	✓	-	➤531 4.5	
-	-	➤484 2.5	-	➤504 3.5	-	-	➤531 4.5	
-	-	➤484 2.5	-	➤504 3.5	-	✓	➤531 4.5	
-30 +120	-30 +120	➤486 2.8	-30 +120	➤505 3.8	-30 +120	-40 ⁴⁾ +80	➤532 4.8	
++	++	➤484 2.6	-	➤504 3.6	-	-	➤531 4.6	
+	(+)	➤488 2.11 ➤24	+	➤506 3.11 ➤24	+	+	➤534 4.11 ➤24	
(+)	(+)	➤485 2.7 ➤27	-	➤504 3.7	-	-	➤531 4.7	
++	++	➤54	+++	➤54	+++	+++	➤54	
+	+	➤56	-	➤56	-	-	➤56	
(+)	(+)	➤25	(+)	➤25	- ⁶⁾	-	➤525 ➤25	
+	+	➤139	+	➤139	+ ⁶⁾	+	➤139	
+	+	➤139	+	➤139	+ ⁶⁾	+	➤139	
✓	✓	➤480	✓	➤500	✓ ⁷⁾	-	➤527	X-life
80 300 ⁸⁾	25 120	➤494	20 500 ⁸⁾	➤514	20 400 ⁸⁾	20 300 ⁸⁾	➤542	
494	496		514		542	550		



1 Single row cylindrical roller bearings with cage



Single row cylindrical roller bearings with cage are suitable where:

- bearing arrangements are subjected to very high radial loads >417|1.2
- not only high radial forces but also axial loads from one or both directions must be supported by the bearing position (semi-locating or locating bearing function) >417|1.2
- bearing arrangements must have very high rigidity
- axial displacements of the shaft relative to the housing must be compensated without constraint in the bearing (in the case of bearings with a non-locating or semi-locating bearing function) >412|1.1
- high radial loads and very high speeds occur but the very high radial load carrying capacity of full complement cylindrical roller bearings is not required >420|1.6
- the bearings should be separable (one bearing ring can be removed) for easier mounting >412|1.1.

For an overview of other product-specific features, see the Matrix for bearing preselection >410.

1
Cylindrical roller bearing with cage/full complement bearing, comparison of speed and load carrying capacity

n_G = limiting speed
 C_r = basic dynamic load rating
 SL1923 = full complement cylindrical roller bearing
 NJ23 = cylindrical roller bearing with cage

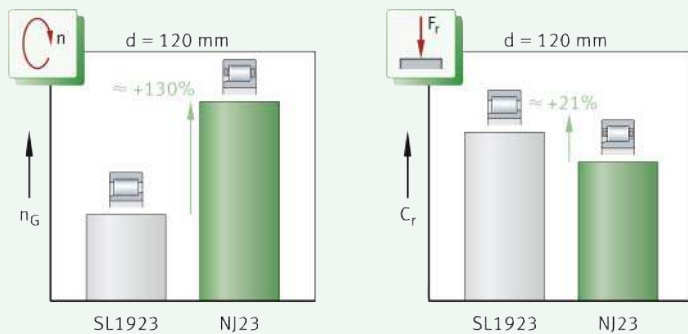

1.1 Bearing design

Design variants

Single row cylindrical roller bearings with cage are available in the basic design as:

- type NU (non-locating bearing) >414|3
- type N (non-locating bearing) >414|3
- type NJ (semi-locating bearing) >414|4
- type NUP (locating bearing) >414|4
- X-life bearings >415.



In addition to the bearings described here, Schaeffler supplies single row cylindrical roller bearings with cage in other types, series and dimensions. These products are described in some cases in special publications. If necessary, please contact Schaeffler. Larger catalogue bearings > GL 1.

Bearings of basic design – standard range

Key features

Single row cylindrical roller bearings with cage are part of the group of radial roller bearings. In contrast to the ball, the roller has a larger contact area perpendicular to the roller axis. As a result, it can transmit higher forces, has greater rigidity and allows smaller rolling element diameters under the same load. The single row bearings comprise solid outer rings, inner rings and cages that are fitted with a large number of cylindrical rollers. The rollers have profiled ends, i.e. they have a slight lateral curvature towards the ends. This modified line contact between the rolling elements and raceways prevents damaging edge stresses [▶ 413](#) |  2. In all standard designs, the cylindrical rollers are guided between rigid ribs by at least one bearing ring. Together with the cage and rollers, this forms a ready-to-fit unit. The other bearing ring can be removed. As a result, the inner ring and outer ring can be mounted separately. Tight fits can thus be achieved on both rings. Bearings of the basic design are manufactured in many different types that differ essentially in the arrangement of the ribs on the inner ring and outer ring. Depending on the design, they are used as non-locating bearings, semi-locating bearings or locating bearings.

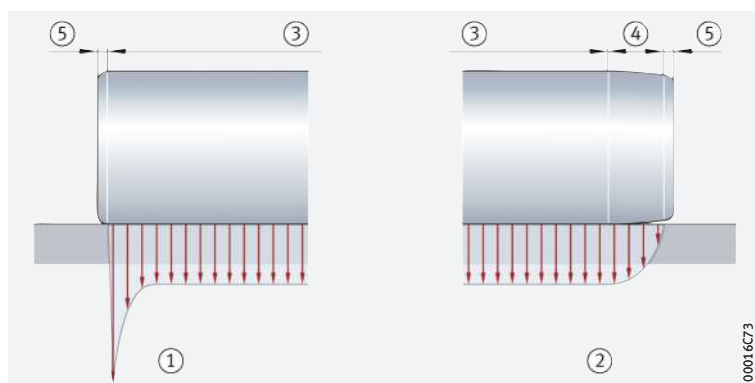

2 Roller profile and stress distribution

- ① Cylindrical roller profile (high stress peaks)
- ② Roller with profiled ends (no stress peak)
- ③ Cylindrical centre region
- ④ Region of logarithmic tapering
- ⑤ Rounding of edge



Type NU

Bearings with non-locating bearing function

In bearings of type NU, the outer ring has two rigid ribs, while the inner ring has no ribs [▶ 414](#) |  3. As a result, axial displacements of the shaft relative to the housing are possible in both directions and within certain limits. During rotational motion, length compensation occurs without constraint in the bearing between the rollers and the raceway without ribs and is therefore practically free from friction. The maximum axial displacement s is given in the product tables. The bearings are used as non-locating bearings, i.e. they cannot guide the shaft axially in either direction [▶ 417](#) | 1.2. For use as semi-locating bearings, they can be combined with the L-section ring HJ [▶ 415](#) |  5.

Type N

Bearings with non-locating bearing function

Cylindrical roller bearings of type N have two rigid ribs on the inner ring, while the outer ring has no ribs [▶ 414](#) |  3. Due to the absence of ribs, axial displacements of the shaft relative to the housing are possible in both directions within the bearing. The maximum axial displacement s is given in the product tables. Bearings of type N are used as non-locating bearings, i.e. they cannot guide the shaft axially in either direction [▶ 417](#) | 1.2.

3

Single row cylindrical roller bearings – non-locating or semi-locating bearings

F_r = radial load

F_a = axial load

- ① Cylindrical roller bearing NU (non-locating bearing)
- ② Cylindrical roller bearing N (non-locating bearing)
- ③ Cylindrical roller bearing NU + L-section ring HJ (semi-locating bearing)

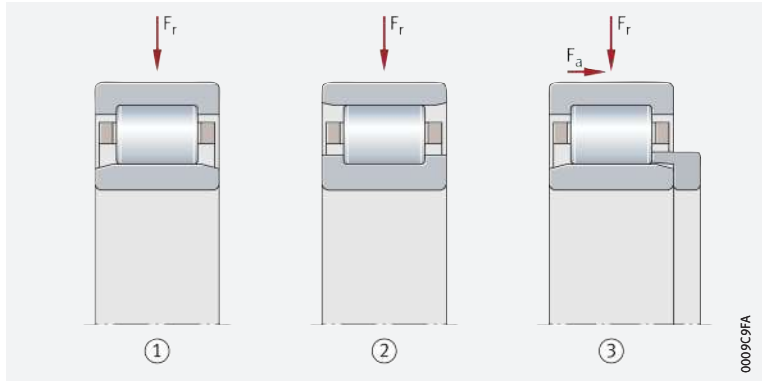

Type NJ

Bearings with semi-locating bearing function

Bearings of type NJ have two rigid ribs on the outer ring and one rigid rib on the inner ring [▶ 414](#) | [☐ 4](#). With these cylindrical roller bearings, axial displacements of the shaft relative to the housing are possible in one direction only. The maximum axial displacement s is given in the product tables. Bearings of type NJ are used as semi-locating bearings, i.e. they can guide the shaft axially in one direction [▶ 417](#) | 1.2. Semi-locating bearings NJ can be combined with an L-section ring HJ to form a locating bearing unit [▶ 415](#) | [☐ 5](#).

Type NUP

Bearings with locating bearing function

Cylindrical roller bearings of type NUP have two rigid ribs on the outer ring as well as one rigid rib and one loose rib washer on the inner ring [▶ 414](#) | [☐ 4](#). With these cylindrical roller bearings, axial displacements between the shaft and the housing are not possible. Bearings of type NUP are used as locating bearings, i.e. they can guide the shaft axially in both directions [▶ 417](#) | 1.2.

4

Single row cylindrical roller bearings – semi-locating or locating bearings

F_r = radial load

F_a = axial load

- ① Cylindrical roller bearing NJ (semi-locating bearing)
- ② Cylindrical roller bearing NUP (locating bearing)

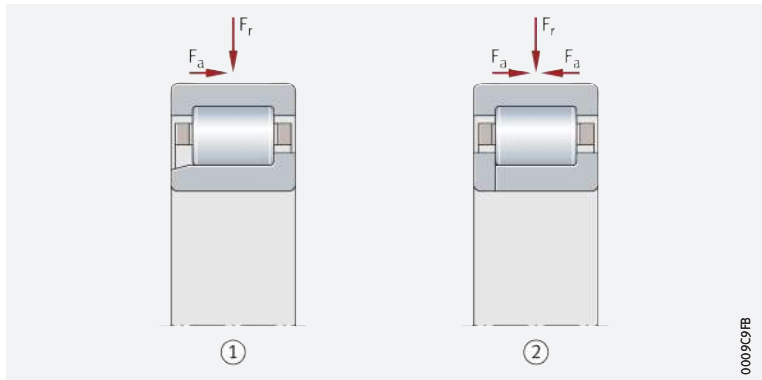

L-section rings

Functional expansion by means of L-section rings

In order to expand the function of cylindrical roller bearings NU and NJ, these types can be combined with L-section rings HJ [▶ 415](#) | [☐ 5](#). In this way, bearings NU can perform a semi-locating bearing function, while bearings NJ in combination with L-section rings can perform a locating bearing function [▶ 415](#) | [☐ 5](#).



Cylindrical roller bearings NU must not be mounted with two L-section rings, since this can lead to axial bracing of the rollers.

Areas of application of L-section rings

L-section rings can be advantageous where:

- the inner ring in locating bearing arrangements that are subjected to high loads has a very tight fit; bearings of type NJ + HJ permit tighter fits than bearings NUP, which have a shortened inner ring and a loose rib washer
- the shaft must be axially guided in one or both directions and bearings NJ or NUP are not available
- the design of the bearing arrangement and the mounting and dismounting of the bearings should be simplified.

Design of L-section rings

The L-section rings are made from rolling bearing steel and are hardened and ground. The axial runout of the lateral faces corresponds to the normal tolerances of the appropriate bearings. Where available, the L-section rings are listed in the product tables together with the associated bearings (e.g. bearing NJ206-E-TVP2 + L-section ring HJ206-E). Since the L-section rings are not a component of the bearing, these must always be ordered together with the bearing ➤ 426 | 14.

5

Cylindrical roller bearings with L-section rings – semi-locating or locating bearings

F_r = radial load
 F_a = axial load

- ① Cylindrical roller bearing NU + L-section ring HJ (semi-locating bearing)
- ② Cylindrical roller bearing NJ + L-section ring HJ (locating bearing)

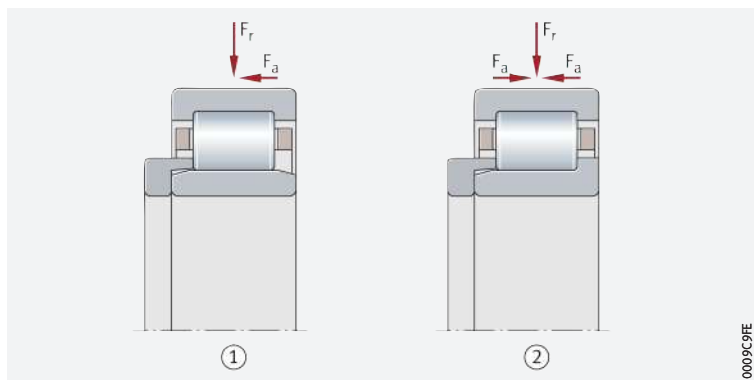

X-life

X-life premium quality

Single row cylindrical roller bearings with cage are supplied up to an outside diameter $D = 320$ mm as X-life bearings ➤ 415 | 6. These bearings exhibit considerably higher performance than comparable standard cylindrical roller bearings. This is achieved, for example, through the modified internal construction, the optimised contact geometry between the rollers and raceways, the better surface quality ➤ 416 | 7 and the optimised roller guidance and lubricant film formation.

6

Cylindrical roller bearing in X-life design

- ① Brass cage
- ② Cylindrical roller, honed
- ③ Outer ring, honed
- ④ Inner ring, honed

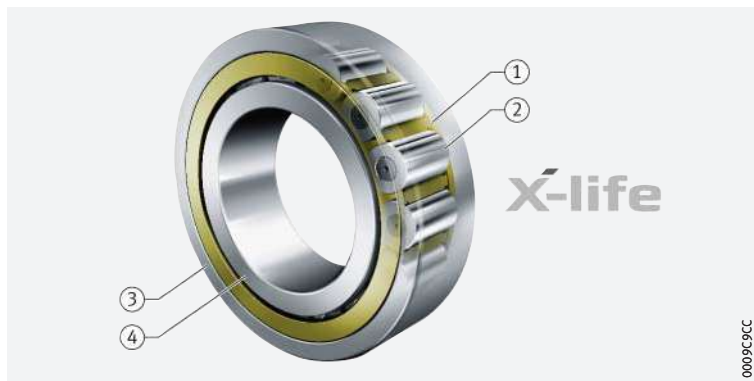

7

Comparison of surface qualities

- ① Standard surface – a rough surface causes stress peaks under radial load
- ② X-life surface – a higher surface quality reduces stress peaks; this increases the bearing operating life

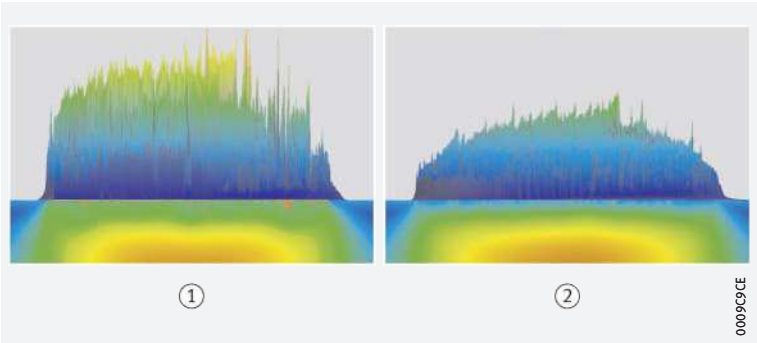

Increased customer benefits due to X-life

Interchangeable with comparable standard bearings

Lower operating costs, higher machine availability

Suffix XL

Advantages

These technical enhancements offer a range of advantages, such as:

- a more favourable load distribution in the bearing and thus a higher dynamic load carrying capacity of the bearings ➤ 413 | 2 and ➤ 416 | 8
- a higher fatigue limit load
- lower heat generation in the bearing
- lower lubricant consumption and therefore longer maintenance intervals if relubrication is carried out
- a measurably longer operating life of the bearings
- high operational security
- compact, environmentally-friendly bearing arrangements.

Since X-life cylindrical roller bearings have the same dimensions as the corresponding standard bearings, the latter can be replaced without any problems by the higher-performance X-life bearings.

The major advantages of X-life can therefore also be used for existing bearing arrangements with standard bearings.

In conclusion, these advantages improve the overall cost-efficiency of the bearing position significantly and thus bring about a sustainable increase in the efficiency of the machine and equipment.

X-life cylindrical roller bearings include the suffix XL in the designation ➤ 425 | 1.12 and ➤ 434 | 8.

8

Cylindrical roller bearing with cage: comparison of basic dynamic load rating C_r with bearings without X-life quality

C_r = radial basic dynamic load rating

- ① Bearing without X-life quality
- ② X-life cylindrical roller bearing

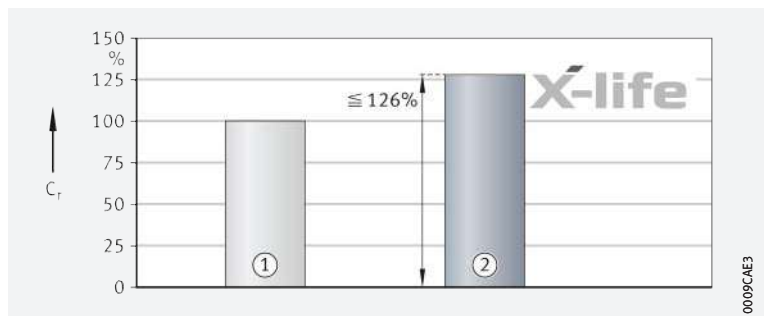

Areas of application

Due to their special technical features, X-life cylindrical roller bearings are highly suitable, for example, for bearing arrangements in:

- heavy industry (steel production)
- power transmission (gearbox engineering)
- processing machines and construction machinery
- wind turbines (gearbox applications).



X-life indicates a high product performance density and thus a particularly significant benefit to the customer. Further information on X-life ► 10.

1.2 Load carrying capacity

☞ *Designed for very high radial loads*

Depending on the type, single row cylindrical roller bearings can support not only very high radial forces but also high axial loads on one or both sides:

- The types N and NU can only support radial loads. If NU bearings are combined with an L-section ring, these can also support axial loads on one side ► 414 | ☞ 3.
- The type NJ can support axial loads on one side and radial loads. If this type is combined with an L-section ring, it can support axial loads on both sides ► 415 | ☞ 5.
- The type NUP can support axial loads on both sides and radial loads.

☞ *Higher capacity roller set in variant E*

Bearings with the suffix E have a higher capacity roller set and are thus designed for very high load carrying capacity.



☞ *Neither wear nor fatigue occurs on the rib contact running and roller end faces*

Higher axial load carrying capacity of bearings with toroidal crowned roller end face

In the case of cylindrical roller bearings with toroidal crowned rollers (TB design), the axial load carrying capacity has been significantly improved with the aid of new calculation and manufacturing methods. A special curvature of the roller end faces facilitates optimum contact conditions between the rollers and ribs ► 417 | ☞ 9. As a result, the axial contact pressures on the rib are significantly minimised and a lubricant film capable of supporting higher loads is formed. Under standard operating conditions, this completely eliminates wear and fatigue at the rib contact running and roller end faces. In addition, the frictional torque is reduced by up to 50%. The bearing temperature during operation is therefore significantly lower. Bearings of the toroidal crowned design are available for a bore diameter of, or larger than, $d = 170 \text{ mm}$ ► 434 | ☞ 11.

☞ 9
Contact geometry of roller end face/rib face – modified roller end faces

- ① Cylindrical roller with inner ring
- ② Detail (representation not to scale)
- ③ End of roller
- ④ Rib

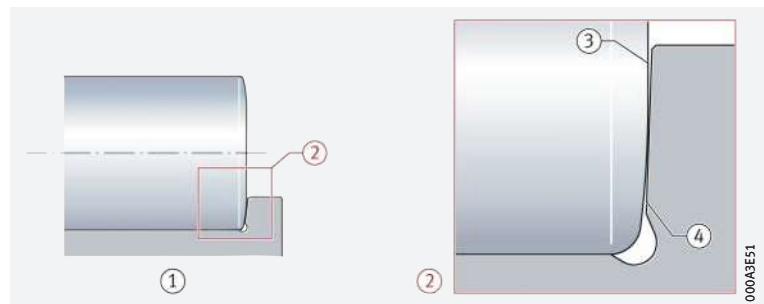

Load ratio F_a/F_r

Ratio $F_a/F_r \leq 0,4$ or $0,6$

The bearings can support axial loads on one side by means of the ribs on the inner and/or outer ring ▶ 418 | 10. In order to ensure problem-free running (tilting of the rollers is prevented), they must always be subjected to radial load at the same time as axial load. The ratio F_a/F_r must not exceed the value 0,4. For bearings with toroidal roller ends (TB design), values up to 0,6 are permissible.



Continuous axial loading without simultaneous radial loading is not permissible.

Permissible axial load

Influencing factors on the axial load carrying capacity

Axial loads are supported by the bearing ribs and the roller end faces ▶ 414 | 4. The axial load carrying capacity of the bearing is therefore essentially dependent on:

- the size of the sliding surfaces between the ribs and the end faces of the rolling elements
- the sliding velocity at the ribs
- the lubrication of the contact surfaces
- tilting of the bearing
- friction.

10 Force flow under axial load – semi-locating bearing NJ

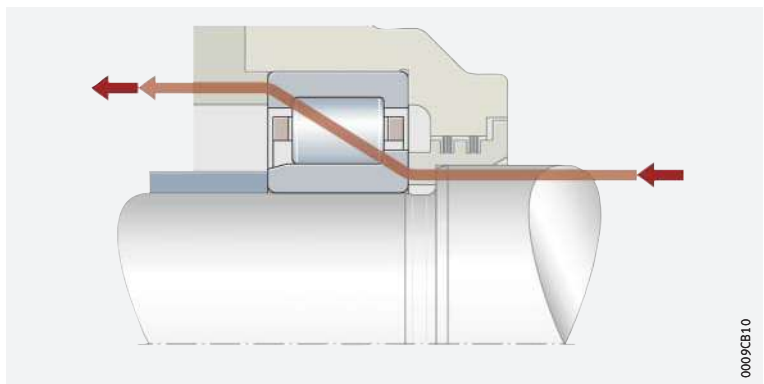

Calculation of permissible axial load – cylindrical rollers with conventional roller ends

Bearings with standard roller ends

The permissible axial load $F_{a\ per}$ can be calculated from the hydrodynamic load carrying capacity of the contact ▶ 418 | f1.

f1 Permissible axial load – bearings of standard design

$$F_{a\ per} = k_S \cdot k_B \cdot d_M^{1,54} \cdot n^{-0,6} \leq F_{a\ max}$$

Legend

$F_{a\ per}$	N	Permissible continuous axial load. In order to prevent unacceptably high temperatures in the bearing, $F_{a\ per}$ must not be exceeded
$F_{a\ max}$	N	Maximum continuous axial load in relation to rib fracture. In order to prevent unacceptably high pressures at the contact surfaces, $F_{a\ max}$ must not be exceeded
k_S	–	Factor as a function of lubrication method ▶ 419 1. The factor takes into consideration the lubrication method used for the bearing. The better the lubrication and, in particular, the heat dissipation, the higher the permissible axial load
k_B	–	Factor as a function of bearing series ▶ 419 2
d_M	mm	Mean bearing diameter $d_M = (D + d)/2$ ▶ 434 1
n	min ⁻¹	Operating speed.

1
Factor k_S

Lubrication method	Factor k_S	
	from	to
Minimal heat dissipation, drip feed oil lubrication, oil mist lubrication, low operating viscosity ($\nu < 0,5 \cdot \nu_1$)	7,5	10
Poor heat dissipation, oil sump lubrication, oil spray lubrication, low oil flow	10	15
Good heat dissipation, recirculating oil lubrication (pressurised oil lubrication)	12	18
Very good heat dissipation, recirculating oil lubrication with oil cooling, high operating viscosity ($\nu > 2 \cdot \nu_1$)	16	24



The precondition for these k_S values is an operating viscosity of the lubricant of at least the reference viscosity ν_1 in accordance with DIN ISO 281:2010.



Doped lubricating oils should be used, such as CLP (DIN 51517) and HLP (DIN 51524) of ISO VG grades 32 to 460, as well as ATF oils (DIN 51502) and transmission oils (DIN 51512) of SAE viscosity grades 75W to 140W.

2
Bearing factor k_B

Series	Factor k_B
NJ2...-E, NJ22...-E, NUP2...-E, NUP22...-E	15
NJ3...-E, NJ23...-E, NUP3...-E, NUP23...-E	20
NJ4	22

Calculation of permissible axial load – cylindrical rollers with toroidal roller ends

Higher axial loads possible

For bearings with toroidal roller ends, the permissible axial loads are 50% higher **► 419 | f1 2.**

f1 2
Permissible axial load – bearings of TB design

$$F_{a\text{ per}} = 1,5 \cdot k_S \cdot k_B \cdot d_M^{1,54} \cdot n^{-0,6} \leq F_{a\text{ max}}$$

Calculation of maximum permissible axial load



For bearings with rollers of the standard or TB design, the maximum permissible axial load $F_{a\text{ max}}$ **► 419 | f1 3** is calculated from the rib strength and the security against wear. This must not be exceeded, even if $F_{a\text{ per}}$ gives higher values **► 419 | f1 4.**

f1 3
Maximum axial load – bearings of standard and TB design

$$F_{a\text{ max}} = 0,075 \cdot k_B \cdot d_M^{2,1}$$

f1 4
Permissible axial load

$$F_{a\text{ per}} \leq F_{a\text{ max}}$$

Axial load under shaft deflection

Permissible axial load under shaft deflection of up to 2'

Under considerable shaft deflection, the shaft shoulder presses against the inner ring rib. In combination with the active axial load, this can lead to high alternating loading of the inner ring ribs. Under a shaft deflection of up to 2', the permissible axial load can be estimated **► 419 | f1 5.**



If more severe tilting is present, a separate strength analysis is required. In this case, please contact Schaeffler.

f1 5
Axial load under misalignment

$$F_{a\text{ s}} = 20 \cdot d_M^{1,42}$$

Legend

$F_{a\text{ s}}$ | N | Permissible axial load under misalignment.



1.3 Compensation of angular misalignments

Angular deviations are misalignments between the inner and outer ring

The possible misalignment between the inner ring and outer ring is influenced by the internal bearing construction, the operating clearance, the forces acting on the bearing etc. Due to these complex relationships, it is not possible to give generally valid absolute values here. However, misalignments (angular deviations) between the inner ring and outer ring will generally always have an effect on the running noise and the operating life of the bearings.

Permissible tilting

The permissible guide values at which, based on experience, there is no significant reduction in operating life are as follows:

- 4' for series 10, 19, 2, 3, 4
- 3' for series 22, 23.

Scope of values

The values apply to:

- bearing arrangements with static misalignment (consistent position of the shaft and housing axis)
- bearings that are not required to perform an axial guidance function
- bearings subjected to small loads (with $C_{0r}/P \geq 5$).



Checking by means of the calculation program BEARINX is recommended in all cases. If there is any uncertainty regarding possible misalignment, please consult Schaeffler.

1.4 Lubrication

Oil or grease lubrication

Single row cylindrical roller bearings with cage are not greased. They must be lubricated with oil or grease.

Compatibility with plastic cages

When using bearings with plastic cages, compatibility between the lubricant and the cage material must be ensured if synthetic oils, lubricating greases with a synthetic oil base or lubricants containing a high proportion of EP additives are used.



If there is any uncertainty regarding the suitability of the selected lubricant for the application, please consult Schaeffler or the lubricant manufacturer.

Observe oil change intervals

Aged oil and additives in the oil can impair the operating life of plastics at high temperatures. As a result, stipulated oil change intervals must be strictly observed.

1.5 Sealing

Provide seals in the adjacent construction

The bearings are not sealed; i.e. sealing of the bearing position must be carried out in the adjacent construction. This must reliably prevent:

- moisture and contaminants from entering the bearing
- the egress of lubricant from the bearing.

1.6 Speeds

Limiting speeds and reference speeds in the product tables

The product tables give two speeds for most bearings ▶ 434 |

- the kinematic limiting speed n_G
- the thermal speed rating $n_{\vartheta r}$.

Limiting speeds



The limiting speed n_G is the kinematically permissible speed of the bearing. Even under favourable mounting and operating conditions, this value should not be exceeded without prior consultation with Schaeffler ▶ 64.

Reference speeds

$n_{\vartheta r}$ is used to calculate n_{ϑ}

The thermal speed rating $n_{\vartheta r}$ is not an application-oriented speed limit, but is a calculated ancillary value for determining the thermally safe operating speed n_{ϑ} ▶ 64.

1.7 Noise

The Schaeffler Noise Index (SGI) has been developed as a new feature for comparing the noise level of different bearing types and series. As a result, a noise evaluation of rolling bearings can now be carried out for the first time.

Schaeffler Noise Index

The SGI value is based on the maximum permissible noise level of a bearing in accordance with internal standards, which is calculated on the basis of ISO 15242. In order that different bearing types and series can be compared, the SGI value is plotted against the basic static load rating C_0 .

This permits direct comparisons between bearings with the same load carrying capacity. The upper limit value is given in each of the diagrams. This means that the average noise level of the bearings is lower than illustrated in the diagram.

 The Schaeffler Noise Index is an additional performance characteristic in the selection of bearings for noise-sensitive applications. The specific suitability of a bearing for an application in terms of installation space, load carrying capacity or speed limit for example, must be checked independently of this.

 The Noise Index is currently available for the main series. Additional series will be updated and introduced in subsequent publications.

Further information:

■ **medias** > <https://medias.schaeffler.com>.

11 Schaeffler Noise Index for single row cylindrical roller bearings with cage

SGI = Schaeffler Noise Index
 C_0 = basic static load rating

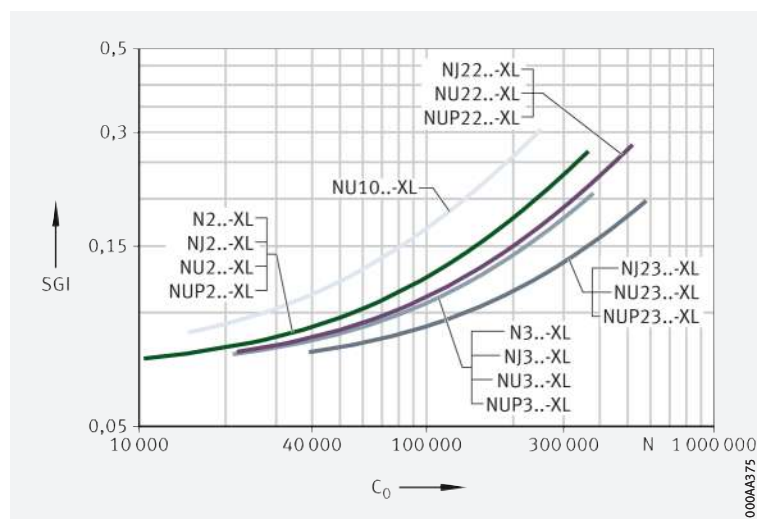

1.8 Temperature range

Limiting values

The operating temperature of the bearings is limited by:

- the dimensional stability of the bearing rings and cylindrical rollers
- the cage
- the lubricant.

Possible operating temperatures of single row cylindrical roller bearings
▶ 422 | 3.

Permissible temperature ranges

Operating temperature	Single row cylindrical roller bearings	
	with polyamide cage PA66	with brass or sheet steel cage
	-30 °C to +120 °C	-30 °C to +150 °C For continuous operating temperatures higher than +120 °C, please contact us



In the event of anticipated temperatures which lie outside the stated values, please contact Schaeffler.

1.9 Cages

The right cage for any purpose

Standard materials are plastic, brass and steel

Approximately two-thirds of Schaeffler cylindrical roller bearings are supplied with cages. For standard applications, the cage materials used essentially are plastic, brass and sheet steel. A large number of cage types and sizes are designed using these three materials. As a result, the right bearing – in accordance with the operating conditions – is always available. For cylindrical roller bearings standardised in accordance with DIN 5412, there are four standard cages available for selection. A summary of the various cage characteristics and their suitability for certain applications is shown in ▶ 423 | 4.

Plastic cage TVP2

The highly versatile plastic cage TVP2 is the standard cage for bearings up to a medium bearing diameter ▶ 423 | 5. In comparison with metal cages, it has a range of advantages: low mass, low running noises due to good damping, high elasticity, good tribological characteristics with steel rolling elements and very good emergency running characteristics. This cage is thus a good choice for applications that allow the use of a plastic cage. Due to their wide-ranging positive characteristics, such plastic cages are now in use in many millions of bearings and applications.

Two-piece solid brass cage M1

A classic design of brass cage is the two-piece, riveted-bar brass cage M1 ▶ 423 | 5. It comprises a so-called comb cage and a cage cover. The cage parts are joined by means of hot riveting, where the rivet pin is integrated in the cage comb.

One-piece, milled brass cage MPAX/MPBX

The brass cage MPAX or MPBX is intended for demanding conditions, such as the high speeds and radial accelerations occurring in planetary gear bearing arrangements ▶ 423 | 4. The optimised pocket geometry and the minimised mass allow a lower running temperature than comparable brass cages. The cages differ in the type of rib guidance. Cage MPAX is guided on the outer ring rib and cage MPBX is guided on the inner ring rib.

Sheet steel cage JP3

For applications that require increased temperature resistance, good lubrication and high geometrical stability of the cage, a bearing with a sheet steel cage is often the most economical solution ▶423| 4. With the aid of highly developed manufacturing technologies, the geometry of the crosspieces and thus the running contact of the rollers on the cage bars is significantly improved. This goes hand in hand with a favourable surface structure, which has a positive influence on lubricant film formation.



Cage, cage characteristics, suitability

+++ = extremely suitable
+ = suitable
- = less suitable

Criteria	Cage				
	TVP2	M1	JP3	MPAX	MPBX
Large number of rolling elements	+	+	+	+	+
High radial cage rigidity	-	+++	+	+++	+++
Low mass	+++	-	+	-	-
Good emergency running (damage case)	-	+++	+	+++	+++
Low noise	+++	+	+	+	+
High guidance normal acceleration	+	+	+	+++	+++
Strong vibrations	+	+	+	+++	+++
Relubrication facility	-	-	+++	+	+
Grease/oil compatibility	-	+	+++	+	+
Application temperatures > 120 °C	-	+	+++	+	+
Large temperature fluctuations	-	+	+++	+	+



Solid cages made from brass and polyamide PA66 are used as standard

Standard cages are shown in ▶423| 5. The cage design is dependent on the bearing series and the bore code. Other cage designs are available by agreement. With such cages, however, suitability for high speeds and temperatures as well as the basic load ratings may differ from the values for the bearings with standard cages.



For high continuous temperatures and applications with difficult operating conditions, bearings with brass cages should be used. If there is any uncertainty regarding cage suitability, please consult Schaeffler.



Cage, cage suffix, bore code

Bearing series	Solid cage made from polyamide PA66	Solid brass cage
	TVP2 standard Bore code	M1 standard
NU10	-	from 05
NU19	-	from 92
NU2..-E, NJ2..-E, NUP2..-E	up to 26	from 28
NU3..-E, NJ3..-E, NUP3..-E	up to 28	from 30
NU4, NJ4	-	all
NU22..-E, NJ22..-E	up to 26	from 28
NU23..-E, NJ23..-E	up to 22	from 24
N2..-E	up to 20, 22 to 26	21, from 28
N3..-E	up to 16	from 17
NUP22..-E	up to 26	from 28
NUP23..-E	up to 22	from 24

1.10 Internal clearance

Radial internal clearance

The standard is CN

Cylindrical roller bearings with cage are manufactured as standard with the radial internal clearance CN (normal) 424 6. CN is not stated in the designation.



Certain sizes are also available by agreement with the larger internal clearance C3, C4 and C5 424 6.



The values for radial internal clearance correspond to DIN 620-4:2004 (ISO 5753-1:2009) 424 6. They are valid for bearings which are free from load and measurement forces (without elastic deformation).

6
Radial internal clearance
of single row cylindrical
roller bearings with cage

Nominal bore diameter d mm		Radial internal clearance							
		CN (Group N)		C3 (Group 3)		C4 (Group 4)		C5 (Group 5)	
over	incl.	μm		μm		μm		μm	
		min.	max.	min.	max.	min.	max.	min.	max.
-	24	20	45	35	60	50	75	65	90
24	30	20	45	35	60	50	75	70	95
30	40	25	50	45	70	60	85	80	105
40	50	30	60	50	80	70	100	98	125
50	65	40	70	60	90	80	110	110	140
65	80	40	75	65	100	90	125	130	165
80	100	50	85	75	110	105	140	155	190
100	120	50	90	85	125	125	165	180	220
120	140	60	105	100	145	145	190	200	245
140	160	70	120	115	165	165	215	225	275
160	180	75	125	120	170	170	220	250	300
180	200	90	145	140	195	195	250	275	330
200	225	105	165	160	220	220	280	305	365
225	250	110	175	170	235	235	300	330	395
250	280	125	195	190	260	260	330	370	440
280	315	130	205	200	275	275	350	410	485
315	355	145	225	225	305	305	385	455	535
355	400	190	280	280	370	370	460	510	600
400	450	210	310	310	410	410	510	565	665
450	500	220	330	330	440	440	550	625	735
500	560	240	360	360	480	480	600	690	810
560	630	260	380	380	500	500	620	780	900
630	710	285	425	425	565	565	705	865	1005

1.11 Dimensions, tolerances

Dimension standards



The main dimensions of cylindrical roller bearings correspond to ISO 15:2017 (DIN 616:2000 and DIN 5412-1:2005).

The main dimensions of L-section rings HJ correspond to ISO 246:1995 (DIN 5412-1:2005).

Chamfer dimensions



The limiting dimensions for chamfer dimensions correspond to DIN 620-6:2004. Overview and limiting values ▶ 135 | 7.11.

Nominal value of chamfer dimension ▶ 434 |

Tolerances



The dimensional tolerances of cylindrical roller bearings correspond to the tolerance class Normal, the running tolerance to the tolerance class 6 in accordance with ISO 492:2014. Tolerance values in accordance with ISO 492 ▶ 124 | .

1.12 Suffixes

For a description of the suffixes used in this chapter ▶ 425 | 7 and **medias** interchange ▶ <https://www.schaeffler.de/std/1D52>.



7
Suffixes and corresponding descriptions

Suffix	Description of suffix	
C3	Radial internal clearance C3 (larger than normal)	Available by agreement
C4	Radial internal clearance C4 (larger than C3)	
C5	Radial internal clearance C5 (larger than C4)	
E	Increased capacity design	Standard
EX	Increased capacity design, design modified in accordance with standard (parts from these bearings must not be interchanged with parts from bearings of the same size of the previous design E)	
JP3	Sheet steel window cage, single-piece, roller-guided	Available by agreement
J30P	Black oxide coated (Durotect B)	
MPAX	Solid brass cage, single-piece, rib-guided on outer ring	
MPBX	Solid brass cage, single-piece, rib-guided on inner ring	
M1	Solid brass cage, two-piece, roller-guided	Standard
M1A	Solid brass cage, two-piece, rib-guided on outer ring	Available by agreement
M1B	Solid brass cage, two-piece, rib-guided on inner ring	
TB	Bearing with increased axial load carrying capacity (toroidal crowned design)	Standard, dependent on bearing size
TVP2	Solid window cage made from glass fibre reinforced polyamide PA66	Standard
XL	X-life bearing	

1.13 Structure of bearing designation

Examples of composition of bearing designation

The designation of bearings follows a set model. Examples ▶ 426 | 12 to ▶ 426 | 14. The composition of designations is subject to DIN 623-1 ▶ 102 | 10.

12
Single row cylindrical roller bearing with cage – bearing with non-locating bearing function: designation structure

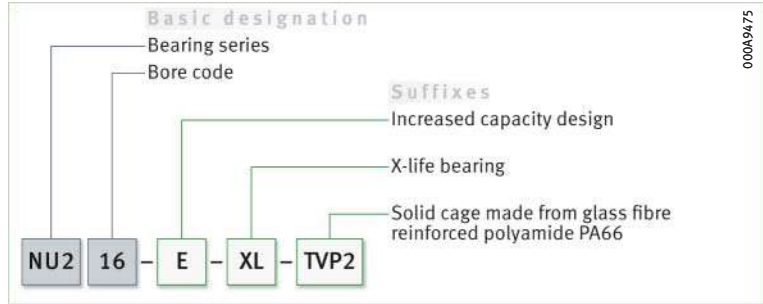

13
Single row cylindrical roller bearing with cage – bearing with semi-locating bearing function: designation structure

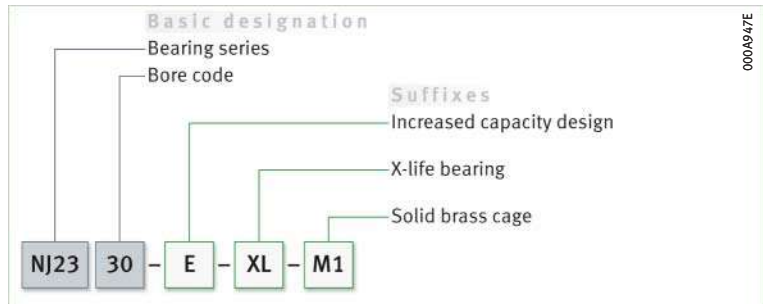

14
Single row cylindrical roller bearing with cage, type NJ with L-section ring – bearing with locating bearing function: designation structure

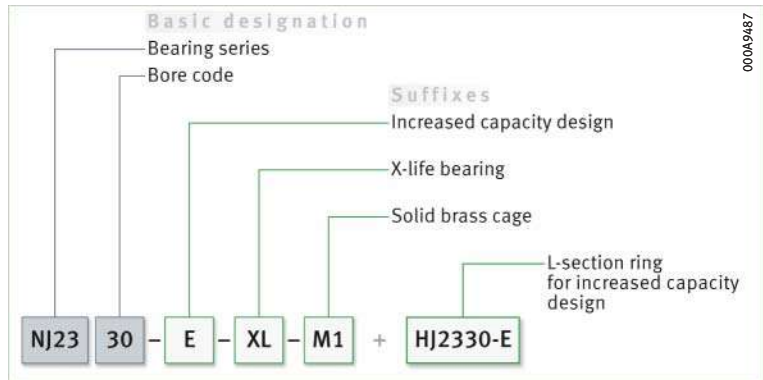

1.14 Dimensioning

$P = F_r$ under purely radial load of constant magnitude and direction

Equivalent dynamic bearing load

The basic rating life equation $L = (C_r/P)^P$ used in the dimensioning of bearings under dynamic load assumes a load of constant magnitude and direction. In radial bearings, this is a purely radial load F_r . If this condition is met, the bearing load F_r is used in the rating life equation for P ($P = F_r$).

$P = F_r$

Cylindrical roller bearings with non-locating bearing function

Non-locating bearings can only support radial loads. For these bearings ▶ 426 | 6.

6
Equivalent dynamic load

$$P = F_r$$

P is a substitute force for combined load and various load cases

Cylindrical roller bearings with semi-locating or locating bearing function

If the condition described above is not met, i.e. if, in addition to the radial force F_r , there is also an axial force F_a , a constant radial force must first be determined for the rating life calculation that (in relation to the rating life) represents an equivalent load. This force is known as the equivalent dynamic bearing load P .

$F_a/F_r \leq e$ or $F_a/F_r > e$

The calculation of P is dependent on the load ratio F_a/F_r and the calculation factors e and Y ▶ 427 | f.7 and ▶ 427 | f.8.

f.7
Equivalent dynamic load

$$\frac{F_a}{F_r} \leq e \Rightarrow P = F_r$$

f.8
Equivalent dynamic load

$$\frac{F_a}{F_r} > e \Rightarrow P = 0,92 \cdot F_r + Y \cdot F_a$$

Legend

P	N	Equivalent dynamic bearing load
F_r	N	Radial load
F_a	N	Axial load
e, Y	-	Factors ▶ 427 f.8.

f.8
Factors e and Y

Bearing series	Calculation factors	
	e	Y
NJ2, NUP2, NJ3, NUP3, NJ4	0,2	0,6
NJ22, NUP22, NJ23, NUP23	0,3	0,4



Equivalent static bearing load

$P_0 = F_{0r}$ For cylindrical roller bearings subjected to static load ▶ 427 | f.9.

f.9
Equivalent static load

$$P_0 = F_{0r}$$

Legend

P_0	N	Equivalent static bearing load
F_{0r}	N	Largest radial load present (maximum load).

Static load safety factor

$S_0 = C_0/P_0$ In addition to the basic rating life $L(L_{10h})$, it is also always necessary to check the static load safety factor S_0 ▶ 427 | f.10.

f.10
Static load safety factor

$$S_0 = \frac{C_0}{P_0}$$

Legend

S_0	-	Static load safety factor
C_0	N	Basic static load rating
P_0	N	Equivalent static bearing load.

1.15 Minimum load

In order to prevent damage due to slippage, a minimum radial load of $P > C_{0r}/60$ is necessary during continuous operation



In order that no slippage occurs between the contact partners, the cylindrical roller bearings must be constantly subjected to a sufficiently high radial load. For continuous operation, experience shows that a minimum radial load of the order of $P > C_{0r}/60$ is thus necessary. In most cases, however, the radial load is already higher than the requisite minimum load due to the weight of the supported parts and the external forces.



If the minimum radial load is lower than indicated above, please consult Schaeffler.

1.16 Design of bearing arrangements

☞ *Support bearing rings over their entire circumference and width*



In order to allow full utilisation of the load carrying capacity of the bearings and achieve the requisite rating life, the bearing rings must be rigidly and uniformly supported by means of contact surfaces over their entire circumference and over the entire width of the raceway. Support can be provided by means of a cylindrical seating surface. The seating and contact surfaces should not be interrupted by grooves, holes or other recesses. The accuracy of mating parts must meet specific requirements ▶ 429 |  9 to ▶ 430 |  11.

☞ *For secure radial location, tight fits are necessary*

Radial location





In addition to supporting the rings adequately, the bearings must also be securely located in a radial direction, to prevent creep of the bearing rings on the mating parts under load. This is generally achieved by means of tight fits between the bearing rings and the mating parts. If the rings are not secured adequately or correctly, this can cause severe damage to the bearings and adjacent machine parts. Influencing factors, such as the conditions of rotation, magnitude of the load, internal clearance, temperature conditions, design of the mating parts and the mounting and dismantling options must be taken into consideration in the selection of fits.



If shock type loads occur, tight fits (transition fit or interference fit) are required to prevent the rings from coming loose at any point. Clearance, transition or interference fits ▶ 150 |  6 and ▶ 158 |  7.



The following information provided in Technical principles must be taken into consideration in the design of bearing arrangements:

- conditions of rotation ▶ 145
- tolerance classes for cylindrical shaft seats (radial bearings) ▶ 147 |  2
- shaft fits ▶ 150 |  6
- tolerance classes for bearing seats in housings (radial bearings) ▶ 148 |  4
- housing fits ▶ 158 |  7.

☞ *The bearings must also be securely located in an axial direction*



Axial location

As a tight fit alone is not normally sufficient to also locate the bearing rings securely on the shaft and in the housing bore in an axial direction, this must usually be achieved by means of an additional axial location or retention method. The axial location of the bearing rings must be matched to the type of bearing arrangement. Shaft and housing shoulders, housing covers, nuts, spacer rings, retaining rings, adapter and withdrawal sleeves etc., are fundamentally suitable ▶ 430 |  15.

☞ *A minimum of IT6 should be provided for the shaft seat and a minimum of IT7 for the housing seat*

Dimensional, geometrical and running accuracy of cylindrical seats

The accuracy of the cylindrical bearing seat on the shaft and in the housing should correspond to the accuracy of the bearing used.

For cylindrical roller bearings with the tolerance class Normal, the shaft seat should correspond to a minimum of standard tolerance grade IT6 and in the housing seat to a minimum of IT7; with tolerance class 6, the shaft seat should correspond to a minimum of IT5 and the housing seat to a minimum of IT6. Guide values for the geometrical and positional tolerances of the bearing seating surfaces ▶ 429 |  9, tolerances t_1 to t_3 in accordance with ▶ 168 |  11. Numerical values for IT grades ▶ 429 |  10.

9
 Guide values
 for the geometrical and
 positional tolerances
 of bearing seating surfaces

Bearing tolerance class		Bearing seating surface	Standard tolerance grades to ISO 286-1 (IT grades)			
to ISO 492	to DIN 620		Diameter tolerance	Roundness tolerance	Parallelism tolerance	Total axial runout tolerance of abutment shoulder
				t_1	t_2	t_3
Normal	PN (P0)	Shaft	IT6 (IT5)	Circumferential load IT4/2	Circumferential load IT4/2	IT4
				Point load IT5/2	Point load IT5/2	
		Housing	IT7 (IT6)	Circumferential load IT5/2	Circumferential load IT5/2	IT5
				Point load IT6/2	Point load IT6/2	
6	P6	Shaft	IT5	Circumferential load IT3/2	Circumferential load IT3/2	IT3
				Point load IT4/2	Point load IT4/2	
		Housing	IT6	Circumferential load IT4/2	Circumferential load IT4/2	IT4
				Point load IT5/2	Point load IT5/2	



10
 Numerical values
 for ISO standard tolerances
 (IT grades) to ISO 286-1:2010

IT grade	Nominal dimension in mm						
	over	10	18	30	50	80	120
	incl.	18	30	50	80	120	180
Values in μm							
IT3	3	4	4	5	6	8	
IT4	5	6	7	8	10	12	
IT5	8	9	11	13	15	18	
IT6	11	13	16	19	22	25	
IT7	18	21	25	30	35	40	

continued ▼

10
 Numerical values
 for ISO standard tolerances
 (IT grades) to ISO 286-1:2010

IT grade	Nominal dimension in mm						
	over	180	250	315	400	500	630
	incl.	250	315	400	500	630	800
Values in μm							
IT3	10	12	13	15	16	18	
IT4	14	16	18	20	22	25	
IT5	20	23	25	27	32	36	
IT6	29	32	36	40	44	50	
IT7	46	52	57	63	70	80	

continued ▲

Roughness of cylindrical bearing seating surfaces

Ra must not be too high

The roughness of the bearing seats must be matched to the tolerance class of the bearings. The mean roughness value Ra must not be too high, in order to maintain the interference loss within limits. The shafts must be ground, while the bores must be precision turned. Guide values as a function of the IT grade of bearing seating surfaces ▶430|11.

11

Roughness values for cylindrical bearing seating surfaces – guide values

Nominal diameter of the bearing seat d (D) mm		Recommended mean roughness value for ground bearing seats Ramax µm			
		Diameter tolerance (IT grade)			
over	incl.	IT7	IT6	IT5	IT4
–	80	1,6	0,8	0,4	0,2
80	500	1,6	1,6	0,8	0,4
500	1 250	3,2 ¹⁾	1,6	1,6	0,8

¹⁾ For the mounting of bearings using the hydraulic method, a value Ra = 1,6 µm must not be exceeded.

Mounting dimensions for the contact surfaces of bearing rings

The contact surfaces for the rings must be of sufficient height

The mounting dimensions of the shaft and housing shoulders, and spacer rings etc., must ensure that the contact surfaces for the bearing rings are of sufficient height. The transition from the bearing seat to the abutment shoulder must be designed with rounding to DIN 5418:1993 or an undercut to DIN 509:2006. Proven mounting dimensions for the radii and diameters of abutment shoulders are given in the product tables ▶430|15 and ▶434|15. These dimensions are limiting dimensions (maximum or minimum dimensions); the actual values should not be higher or lower than specified.

Rib support in axially loaded bearings

Ribs under axial load must be supported over their entire height and entire circumference. The size and axial runout accuracy of the contact surfaces on the inner ring rib must be observed especially in the case of cylindrical roller bearings subjected to high loads, since these factors also influence the uniformity of the rib load and the running accuracy of the shaft. This means that the ribs may be subjected to damaging alternating stresses even in the case of very small misalignments. If the mounting dimensions indicated in the product tables are observed, the problems described can be reliably avoided ▶434|15.

Support in semi-locating bearings

In semi-locating bearings, it is sufficient to support the bearing rings on one side, on the rib supporting the axial load ▶430|15.

15

Support of the inner ring rib – type NJ (semi-locating bearing)

d_c = recommended height of shaft shoulder with axially loaded rib

Arrow = force flow

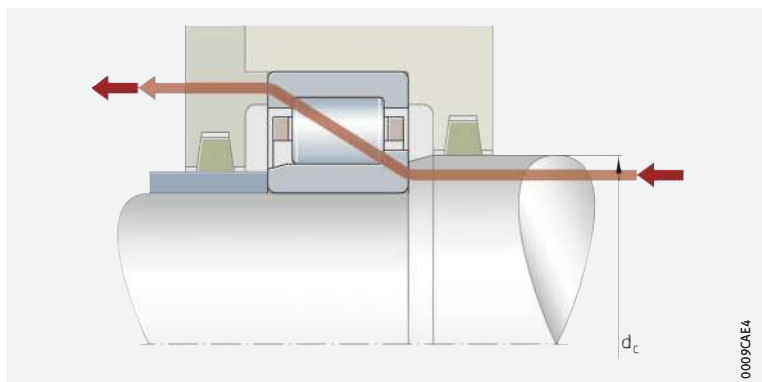

1.17

Mounting and dismounting



The mounting and dismounting options for cylindrical roller bearings, by thermal, hydraulic or mechanical methods, must be taken into consideration in the design of the bearing position.

Since one bearing ring can be removed, the bearings are easy to mount.

Together with the cage and rollers, the bearing ring with the two rigid ribs forms a ready-to-mount unit. The other bearing ring can be removed. As a result, the bearing parts can be mounted separately from each other ► 412 | 1.1. This gives simplified mounting of the bearings, especially when the two bearing rings have a tight fit.

Rolling bearings must be handled with great care

Schaeffler Mounting Handbook

Rolling bearings are well-proven precision machine elements for the design of economical and reliable bearing arrangements, which offer high operational security. In order that these products can function correctly and achieve the envisaged operating life without detrimental effect, they must be handled with care.



The Schaeffler Mounting Handbook MH 1 gives comprehensive information about the correct storage, mounting, dismounting and maintenance of rotary rolling bearings ► <https://www.schaeffler.de/std/1D53>. It also provides information which should be observed by the designer, in relation to the mounting, dismounting and maintenance of bearings, in the original design of the bearing position. This book is available from Schaeffler on request.



1.18

Legal notice regarding data freshness

The further development of products may also result in technical changes to catalogue products

Of central interest to Schaeffler is the further development and optimisation of its products and the satisfaction of its customers. In order that you, as the customer, can keep yourself optimally informed about the progress that is being made here and with regard to the current technical status of the products, we publish any product changes which differ from the printed version in our electronic product catalogue.



We therefore reserve the right to make changes to the data and illustrations in this catalogue. This catalogue reflects the status at the time of printing. More recent publications released by us (as printed or digital media) will automatically precede this catalogue if they involve the same subject. Therefore, please always use our electronic product catalogue to check whether more up-to-date information or modification notices exist for your desired product.

Link to electronic product catalogue

The following link will take you to the Schaeffler electronic product catalogue: ► <https://medias.schaeffler.com>.

1.19 Further information



In addition to the data in this chapter, the following chapters in Technical principles must also be observed in the design of bearing arrangements:

- Determining the bearing size ▶ 34
- Rigidity ▶ 54
- Friction and increases in temperature ▶ 56
- Speeds ▶ 64
- Bearing data ▶ 97
- Lubrication ▶ 70
- Sealing ▶ 182
- Design of bearing arrangements ▶ 139
- Mounting and dismounting ▶ 191.





Cylindrical roller bearings with cage

Non-locating bearings

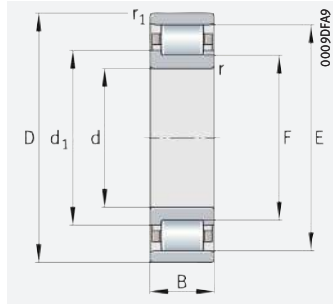

N

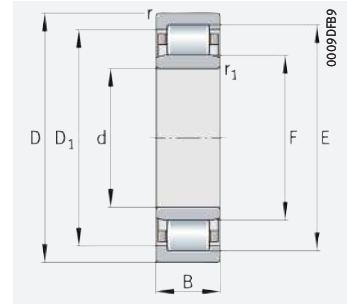

NU

d = 15 – 35 mm

Main dimensions			Basic load ratings		Fatigue limit load	Limiting speed	Speed rating	Mass	Designation
d	D	B	dyn. C _r	stat. C _{0r}	C _{ur}	n _G	n _{gr}	m	▶425 1.12 ▶426 1.13 X-life ▶415
			N	N	N	min ⁻¹	min ⁻¹	≈ kg	
15	35	11	15 100	10 400	1 610	27 000	17 900	0,047	N202-E-XL-TVP2
	35	11	15 100	10 400	1 410	27 000	17 900	0,048	NU202-E-XL-TVP2
17	40	12	20 800	14 600	2 190	22 900	15 300	0,068	N203-E-XL-TVP2
	40	12	20 800	14 600	1 870	22 900	15 300	0,069	NU203-E-XL-TVP2
	40	16	28 500	21 900	3 500	22 900	13 200	0,051	NU2203-E-XL-TVP2
20	47	14	30 000	21 200	2 600	19 600	13 500	0,121	NU303-E-XL-TVP2
	47	14	32 500	24 700	3 900	19 200	12 800	0,112	N204-E-XL-TVP2
	47	14	32 500	24 700	2 900	19 200	12 800	0,114	NU204-E-XL-TVP2
	47	18	38 500	31 000	5 100	19 200	11 100	0,146	NU2204-E-XL-TVP2
	52	15	37 500	27 000	3 100	17 200	11 900	0,153	NU304-E-XL-TVP2
25	52	21	49 500	39 000	6 200	17 200	9 700	0,215	NU2304-E-XL-TVP2
	47	12	18 500	14 800	1 780	26 000	12 900	0,092	NU1005-XL-M1
	52	15	34 500	27 500	4 400	17 200	11 600	0,135	N205-E-XL-TVP2
	52	15	34 500	27 500	3 300	17 200	11 600	0,137	NU205-E-XL-TVP2
	52	18	41 500	34 500	5 700	17 200	9 600	0,165	NU2205-E-XL-TVP2
30	62	17	49 000	37 500	5 600	14 400	10 100	0,242	N305-E-XL-TVP2
	62	17	49 000	37 500	4 450	14 400	10 100	0,245	NU305-E-XL-TVP2
	62	24	67 000	56 000	9 200	14 400	8 200	0,349	NU2305-E-XL-TVP2
	55	13	22 900	19 300	2 410	22 400	11 000	0,134	NU1006-XL-M1
	62	16	46 000	37 500	5 400	14 200	9 600	0,205	N206-E-XL-TVP2
	62	16	46 000	37 500	4 350	14 200	9 600	0,207	NU206-E-XL-TVP2
	62	20	58 000	50 000	7 800	14 200	8 000	0,255	NU2206-E-XL-TVP2
	72	19	61 000	48 000	7 700	12 400	8 900	0,366	N306-E-XL-TVP2
35	72	19	61 000	48 000	6 000	12 400	8 900	0,368	NU306-E-XL-TVP2
	72	27	86 000	75 000	13 100	12 400	7 200	0,529	NU2306-E-XL-TVP2
	90	23	84 000	65 000	8 300	13 400	8 100	0,858	NU406-XL-M1
	62	14	29 000	26 000	3 200	19 700	9 700	0,177	NU1007-XL-M1
35	72	17	59 000	50 000	7 600	12 300	8 100	0,301	N207-E-XL-TVP2
	72	17	59 000	50 000	6 100	12 300	8 100	0,303	NU207-E-XL-TVP2
	72	23	73 000	65 000	10 500	12 300	7 200	0,406	NU2207-E-XL-TVP2
	80	21	76 000	63 000	10 600	10 900	7 900	0,486	N307-E-XL-TVP2
	80	21	76 000	63 000	8 100	10 900	7 900	0,486	NU307-E-XL-TVP2
	80	31	108 000	98 000	17 600	10 900	6 600	0,723	NU2307-E-XL-TVP2
	100	25	103 000	83 000	10 600	11 800	7 000	1,14	NU407-XL-M1

medias ▶ <https://www.schaeffler.de/std/1DA0>

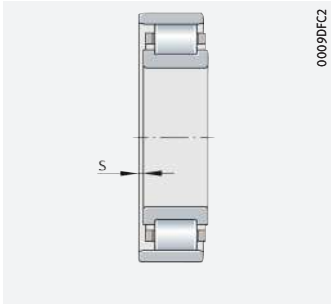

Axial displacement "s" for N and NU

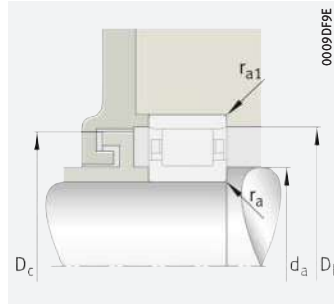

Mounting dimensions for N

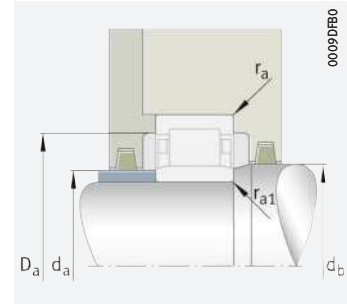

Mounting dimensions for NU

Dimensions

d	r	r ₁	s	E	F	D ₁	d ₁
15	0,6	0,3	0,5	30,3	19,3	-	21,6
	0,6	0,3	1,6	30,3	19,3	28	-
17	0,6	0,3	1,2	35,1	22,1	-	24,9
	0,6	0,3	1,2	35,1	22,1	32,5	-
	0,6	0,3	1,7	35,1	22,1	32,5	-
20	1	0,6	1,2	40,2	24,2	37,1	-
	1	0,6	0,8	41,5	26,5	-	29,7
	1	0,6	0,8	41,5	26,5	38,8	-
	1	0,6	1,8	41,5	26,5	38,8	-
	1,1	0,6	1	45,5	27,5	42,4	-
25	1,1	0,6	1,9	45,5	27,5	42,4	-
	0,6	0,3	2,4	41,5	30,5	39,3	-
	1	0,6	1,3	46,5	31,5	-	34,7
	1	0,6	1,2	46,5	31,5	43,8	-
	1	0,6	1,7	46,5	31,5	43,8	-
	1,1	1,1	1,4	54	34	-	38,1
	1,1	1,1	1,5	54	34	50,7	-
30	1,1	1,1	1,9	54	34	50,7	-
	1	0,6	2,4	48,5	36,5	46,1	-
	1	0,6	1,4	55,5	37,5	-	41,1
	1	0,6	1,5	55,5	37,5	52,5	-
	1	0,6	1,6	55,5	37,5	52,5	-
	1,1	1,1	0,6	62,5	40,5	-	45
	1,1	1,1	1,2	62,5	40,5	59,2	-
	1,1	1,1	2,2	62,5	40,5	59,2	-
35	1,5	1,5	2,3	73	45	68,4	-
	1	0,6	2,6	55	42	52,4	-
	1,1	0,6	0,7	64	44	-	48
	1,1	0,6	0,7	64	44	61	-
	1,1	0,6	2,2	64	44	61	-
	1,5	1,1	0,6	70,2	46,2	-	51
	1,5	1,1	0,6	70,2	46,2	66,6	-
	1,5	1,1	3	70,2	46,2	66,6	-

Mounting dimensions

d _a	d _b	D _a	D _b	D _c	r _a	r _{a1}	
							min.
17,4	-	-	32,6	31	29	0,6	0,3
17,4	18,5	20	32,6	-	-	0,6	0,3
21	-	-	36	36	34	0,6	0,3
21	21,5	23	36	-	-	0,6	0,3
21	21,5	23	36	-	-	0,6	0,3
21,2	23,5	25	42,8	-	-	1	0,6
24	-	-	41	43	40	1	0,6
24	26	29	41	-	-	1	0,6
24	26	29	41	-	-	1	0,6
24	27	30	45	-	-	1	0,6
24	27	30	45	-	-	1	0,6
27	30	32	44	-	-	0,6	0,3
29	-	-	46	48	45	1	0,6
29	31	34	46	-	-	1	0,6
29	31	34	46	-	-	1	0,5
32	-	-	55	55	53	1	1
32	33	37	55	-	-	1	1
32	33	37	55	-	-	1	1
33	35	38	50	-	-	1	0,6
34	-	-	56	57	54	1	0,6
34	37	40	56	-	-	1	0,6
34	37	40	56	-	-	1	0,6
37	-	-	65	64	61	1	1
37	40	44	65	-	-	1	1
37	40	44	65	-	-	1	1
41	44	47	79	-	-	1,5	1,5
38	41	44	57	-	-	1	0,6
39	-	-	65	65	63	1	0,6
39	43	46	65	-	-	1	0,6
39	43	46	65	-	-	1	0,6
42	-	-	71	71	69	1,5	1
42	45	48	71	-	-	1,5	1
42	45	48	71	-	-	1,5	1
46	52	55	89	-	-	1,5	1,5



Cylindrical roller bearings with cage

Non-locating bearings

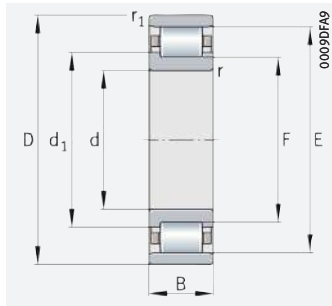

N

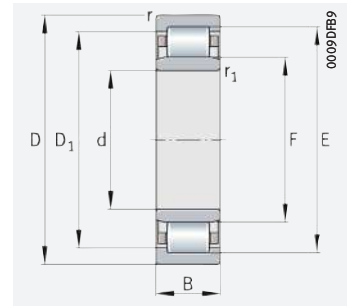

NU

d = 40 – 55 mm

Main dimensions			Basic load ratings		Fatigue limit load	Limiting speed	Speed rating	Mass	Designation
d	D	B	dyn. C_r	stat. C_{0r}	C_{ur}	n_G	$n_{\partial r}$	m	▶ 425 1.12 ▶ 426 1.13 X-life ▶ 415
			N	N	N	min ⁻¹	min ⁻¹	≈ kg	
40	68	15	33 500	30 500	3 800	17 700	8 900	0,216	NU1008-XL-M1
	80	18	63 000	53 000	8 400	10 900	7 500	0,358	N208-E-XL-TVP2
	80	18	63 000	53 000	6 600	10 900	7 500	0,379	NU208-E-XL-TVP2
	80	23	83 000	75 000	12 700	10 900	6 300	0,492	NU2208-E-XL-TVP2
	90	23	96 000	79 000	13 600	9 500	7 100	0,656	N308-E-XL-TVP2
	90	23	96 000	79 000	10 200	9 500	7 100	0,659	NU308-E-XL-TVP2
	90	33	132 000	119 000	21 600	9 500	5 800	0,958	NU2308-E-XL-TVP2
	110	27	119 000	95 000	12 400	10 500	6 500	1,47	NU408-XL-M1
45	75	16	40 000	37 500	4 750	16 000	8 100	0,277	NU1009-XL-M1
	85	19	72 000	63 000	10 300	10 200	7 000	0,434	N209-E-XL-TVP2
	85	19	72 000	63 000	8 100	10 200	7 000	0,434	NU209-E-XL-TVP2
	85	23	87 000	82 000	13 900	10 200	5 800	0,532	NU2209-E-XL-TVP2
	100	25	116 000	99 000	17 300	8 500	6 400	0,891	N309-E-XL-TVP2
	100	25	116 000	99 000	13 200	8 500	6 400	0,893	NU309-E-XL-TVP2
	100	36	163 000	154 000	28 000	8 500	5 200	1,3	NU2309-E-XL-TVP2
	120	29	143 000	119 000	15 600	9 600	5 900	1,87	NU409-XL-M1
50	80	16	42 500	41 500	5 300	15 000	7 400	0,305	NU1010-XL-M1
	90	20	75 000	69 000	11 200	9 700	6 600	0,488	N210-E-XL-TVP2
	90	20	75 000	69 000	8 800	9 700	6 600	0,487	NU210-E-XL-TVP2
	90	23	92 000	88 000	15 000	9 700	5 300	0,573	NU2210-E-XL-TVP2
	110	27	128 000	110 000	20 100	7 800	6 100	1,16	N310-E-XL-TVP2
	110	27	131 000	114 000	15 300	7 800	6 000	1,16	NU310-E-XL-TVP2
	110	40	193 000	187 000	35 000	7 800	4 900	1,75	NU2310-E-XL-TVP2
	130	31	175 000	148 000	19 800	8 600	5 300	2,33	NU410-XL-M1
55	90	18	49 500	50 000	6 600	13 500	6 900	0,446	NU1011-XL-M1
	100	21	99 000	95 000	16 100	8 700	5 800	0,668	N211-E-XL-TVP2
	100	21	99 000	95 000	12 700	8 700	5 800	0,665	NU211-E-XL-TVP2
	100	25	117 000	118 000	20 700	8 700	4 700	0,796	NU2211-E-XL-TVP2
	120	29	159 000	139 000	25 500	7 000	5 500	1,48	N311-E-XL-TVP2
	120	29	159 000	139 000	19 000	7 000	5 500	1,48	NU311-E-XL-TVP2
	120	43	235 000	230 000	43 500	7 000	4 500	2,23	NU2311-E-XL-TVP2
	140	33	187 000	164 000	21 900	8 200	5 100	2,83	NU411-XL-M1

medias ▶ <https://www.schaeffler.de/std/1DA1>

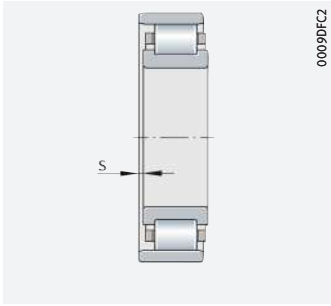

Axial displacement "s" for N and NU

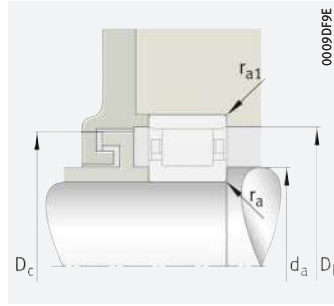

Mounting dimensions for N

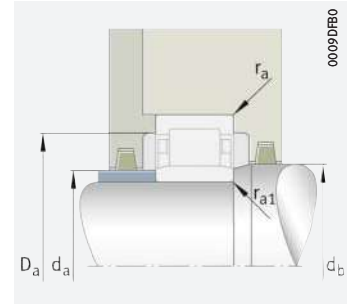

Mounting dimensions for NU

Dimensions

d	r	r ₁	s	E	F	D ₁	d ₁
	min.	min.				≈	≈
40	1	0,6	2	61	47	58,2	-
	1,1	1,1	1	71,5	49,5	-	54
	1,1	1,1	1	71,5	49,5	68,3	-
	1,1	1,1	1,5	71,5	49,5	68,3	-
	1,5	1,5	1,2	80	52	-	57,6
	1,5	1,5	1,3	80	52	75,9	-
	1,5	1,5	2,7	80	52	75,9	-
	2	2	2,8	92	58	86,4	-
45	1	0,6	2,5	67,5	52,5	64,5	-
	1,1	1,1	1	76,5	54,5	-	59
	1,1	1,1	1	76,5	54,5	73,3	-
	1,1	1,1	1,5	76,5	54,5	73,3	-
	1,5	1,5	1	88,5	58,5	-	64,4
	1,5	1,5	1	88,5	58,5	84,1	-
	1,5	1,5	2,5	88,5	58,5	84,1	-
	2	2	2,9	100,5	64,5	94,6	-
50	1	0,6	2,1	72,5	57,5	69,5	-
	1,1	1,1	1,3	81,5	59,5	-	64
	1,1	1,1	1,3	81,5	59,5	78,3	-
	1,1	1,1	1,3	81,5	59,5	78,3	-
	2	2	1,7	97	65	-	71,3
	2	2	1,7	97	65	92,5	-
	2	2	3,2	97	65	92,5	-
	2,1	2,1	3	110,8	70,8	104,3	-
55	1,1	1	2,4	80,5	64,5	77,3	-
	1,5	1,1	0,8	90	66	-	70,8
	1,5	1,1	0,8	90	66	86,6	-
	1,5	1,1	1,3	90	66	86,6	-
	2	2	1,8	106,5	70,5	-	77,5
	2	2	1,8	106,5	70,5	101,4	-
	2	2	3,3	106,5	70,5	101,4	-
	2,1	2,1	3,3	117,2	77,2	110,7	-

Mounting dimensions

d _a		d _b	D _a	D _b	D _c	r _a	r _{a1}	
min.	max.	min.	max.	min.	max.	max.	max.	
40	43	46	49	63	-	-	1	0,6
	47	-	-	73	73	70	1	1
	47	49	52	73	-	-	1	1
	47	49	52	73	-	-	1	1
	49	-	-	81	81	79	1,5	1,5
	49	51	55	81	-	-	1,5	1,5
	49	51	55	81	-	-	1,5	1,5
	53	57	60	97	-	-	2	2
45	48	52	54	70	-	-	1	0,6
	52	-	-	78	78	75	1	1
	52	54	57	78	-	-	1	1
	52	54	57	78	-	-	1	1
	54	-	-	91	90	87	1,5	1,5
	54	57	60	91	-	-	1,5	1,5
	54	57	60	91	-	-	1,5	1,5
	58	63	66	107	-	-	2	2
50	53	57	59	75	-	-	1	0,6
	57	-	-	83	83	80	1	1
	57	58	62	83	-	-	1	1
	57	58	62	83	-	-	1	1
	61	-	-	99	98	96	2	2
	61	63	67	99	-	-	2	2
	61	63	67	99	-	-	2	2
	64	69	73	116	-	-	2	2
55	60	63	66	84	-	-	1,1	1
	62	-	-	91	91	89	1,5	1
	62	65	68	91	-	-	1,5	1
	62	65	68	91	-	-	1,5	1
	66	-	-	109	108	105	2	2
	66	69	72	109	-	-	2	2
	66	69	72	109	-	-	2	2
	69	76	79	126	-	-	2	2



Cylindrical roller bearings with cage

Non-locating bearings

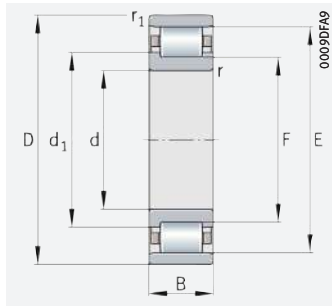

N

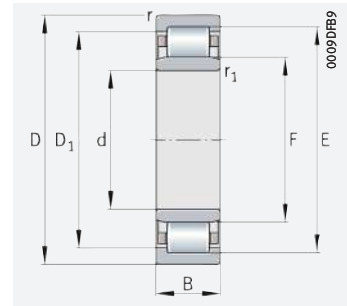

NU

d = 60 – 75 mm

Main dimensions			Basic load ratings		Fatigue limit load C_{ur}	Limiting speed n_G	Speed rating n_{gr}	Mass m	Designation
d	D	B	dyn. C_r	stat. C_{Or}					
			N	N	N	min ⁻¹	min ⁻¹	≈ kg	
60	95	18	52 000	55 000	7 200	12 800	6 400	0,48	NU1012-XL-M1
	110	22	112 000	103 000	13 900	7 700	5 300	0,824	NU212-E-XL-TVP2
	110	22	112 000	103 000	17 800	7 700	5 300	0,827	N212-E-XL-TVP2
	110	28	152 000	153 000	27 500	7 700	4 300	1,08	NU2212-E-XL-TVP2
	130	31	177 000	157 000	28 500	6 500	5 200	1,84	N312-E-XL-TVP2
	130	31	177 000	157 000	21 400	6 500	5 200	1,85	NU312-E-XL-TVP2
	130	46	265 000	260 000	50 000	6 500	4 250	2,78	NU2312-E-XL-TVP2
	150	35	211 000	184 000	24 300	7 500	4 800	3,41	NU412-XL-M1
65	100	18	53 000	58 000	7 600	12 200	5 900	0,507	NU1013-XL-M1
	120	23	128 000	120 000	20 800	7 100	4 900	1,05	N213-E-XL-TVP2
	120	23	128 000	120 000	16 400	7 100	4 900	1,04	NU213-E-XL-TVP2
	120	31	177 000	182 000	33 500	7 100	4 100	1,43	NU2213-E-XL-TVP2
	140	33	214 000	191 000	34 500	5 900	4 800	2,28	N313-E-XL-TVP2
	140	33	214 000	191 000	25 500	5 900	4 800	2,28	NU313-E-XL-TVP2
	140	48	295 000	285 000	54 000	5 900	4 000	3,32	NU2313-E-XL-TVP2
	160	37	230 000	203 000	26 500	7 000	4 600	4,08	NU413-XL-M1
70	110	20	77 000	81 000	10 200	10 700	5 500	0,706	NU1014-XL-M1
	125	24	141 000	138 000	24 300	6 800	4 650	1,16	N214-E-XL-TVP2
	125	24	141 000	138 000	19 000	6 800	4 650	1,15	NU214-E-XL-TVP2
	125	31	185 000	195 000	35 500	6 800	3 850	1,52	NU2214-E-XL-TVP2
	150	35	242 000	222 000	39 500	5 500	4 500	2,79	N314-E-XL-TVP2
	150	35	242 000	222 000	30 000	5 500	4 500	2,79	NU314-E-XL-TVP2
	150	51	325 000	325 000	60 000	5 500	3 800	4,02	NU2314-E-XL-TVP2
	180	42	285 000	255 000	32 500	6 200	4 250	5,97	NU414-XL-M1
75	115	20	78 000	85 000	10 700	10 300	5 200	0,737	NU1015-XL-M1
	130	25	155 000	157 000	27 500	6 500	4 400	1,29	N215-E-XL-TVP2
	130	25	155 000	157 000	21 700	6 500	4 400	1,27	NU215-E-XL-TVP2
	130	31	192 000	208 000	38 000	6 500	3 600	1,6	NU2215-E-XL-TVP2
	160	37	285 000	265 000	46 500	5 100	4 150	3,34	N315-E-XL-TVP2
	160	37	285 000	265 000	34 500	5 100	4 150	3,33	NU315-E-XL-TVP2
	160	55	390 000	395 000	72 000	5 100	3 550	4,95	NU2315-E-XL-TVP2
	190	45	325 000	295 000	37 000	5 800	4 100	7,09	NU415-XL-M1

medias ► <https://www.schaeffler.de/std/1DA2>

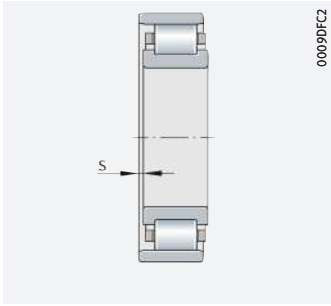

Axial displacement "s" for N and NU

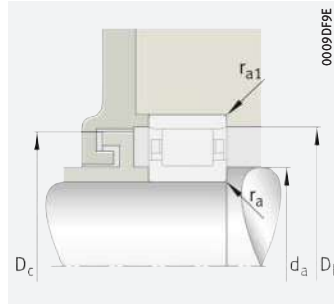

Mounting dimensions for N

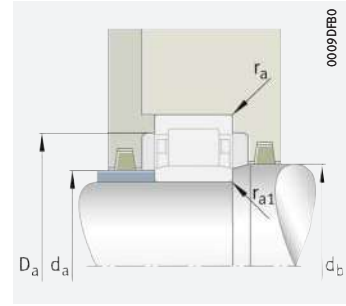

Mounting dimensions for NU

Dimensions

Mounting dimensions

d	r	r ₁	s	E	F	D ₁	d ₁	d _a		d _b		D _a	D _b	D _c	r _a	r _{a1}
								min.	max.	min.	max.					
60	1,1	1	2,4	85,5	69,5	–	82,3	65	68	71	89	–	–	1,1	1	
	1,5	1,5	1,6	100	72	–	96,1	69	71	75	101	–	–	1,5	1,5	
	1,5	1,5	1,6	100	72	77,6	–	69	–	–	101	101	99	1,5	1,5	
	1,5	1,5	1,6	100	72	–	96,1	69	71	75	101	–	–	1,5	1,5	
	2,1	2,1	1,9	115	77	84,4	–	72	–	–	118	116	114	2,1	2,1	
	2,1	2,1	1,8	115	77	–	109,6	72	75	79	118	–	–	2,1	2,1	
	2,1	2,1	3,5	115	77	–	109,6	72	75	79	118	–	–	2,1	2,1	
	2,1	2,1	3,4	127	83	–	119,5	74	82	85	136	–	–	2	2	
65	1,1	1	3,3	90,5	74,5	87,3	–	70	73	76	94	–	–	1,1	1	
	1,5	1,5	1,4	108,5	78,5	–	84,4	74	–	–	111	110	107	1,5	1,5	
	1,5	1,5	1,4	108,5	78,5	104,3	–	74	77	81	111	–	–	1,5	1,5	
	1,5	1,5	1,9	108,5	78,5	104,3	–	74	77	81	111	–	–	1,5	1,5	
	2,1	2,1	1,4	124,5	82,5	–	90,5	77	–	–	128	126	123	2,1	2,1	
	2,1	2,1	1,5	124,5	82,5	118,6	–	77	81	85	128	–	–	2,1	2,1	
	2,1	2,1	4	124,5	82,5	118,6	–	77	81	85	128	–	–	2,1	2,1	
	2,1	2,1	3,5	135,3	89,3	127,7	–	79	88	91	146	–	–	2	2	
70	1,1	1	2,5	100	80	96	–	75	78	82	104	–	–	1	1	
	1,5	1,5	1,2	113,5	83,5	–	89,4	79	–	–	116	115	112	1,5	1,5	
	1,5	1,5	1,2	113,5	83,5	109,4	–	79	82	86	116	–	–	1,5	1,5	
	1,5	1,5	1,6	113,5	83,5	109,4	–	79	82	86	116	–	–	1,5	1,5	
	2,1	2,1	1,6	133	89	–	97,4	82	–	–	138	135	131	2,1	2,1	
	2,1	2,1	1,7	133	89	126,8	–	82	87	92	138	–	–	2,1	2,1	
	2,1	2,1	4,7	133	89	126,8	–	82	87	92	138	–	–	2,1	2,1	
	3	3	4	152	100	142,7	–	86	99	102	164	–	–	2,5	2,5	
75	1,1	1	2,5	105	85	101,7	–	80	83	87	109	–	–	1,1	1	
	1,5	1,5	1,1	118,5	88,5	–	94,4	84	–	–	121	120	117	1,5	1,5	
	1,5	1,5	1,2	118,5	88,5	114,4	–	84	87	90	121	–	–	1,5	1,5	
	1,5	1,5	1,6	118,5	88,5	114,4	–	84	87	90	121	–	–	1,5	1,5	
	2,1	2,1	1,1	143	95	–	104,1	87	–	–	148	145	141	2,1	2,1	
	2,1	2,1	1,2	143	95	136,2	–	87	93	97	148	–	–	2,1	2,1	
	2,1	2,1	4,2	143	95	136,2	–	87	93	97	148	–	–	2,1	2,1	
	3	3	4,5	160,5	104,5	150,7	–	91	103	107	174	–	–	2,5	2,5	





Cylindrical roller bearings with cage

Non-locating bearings

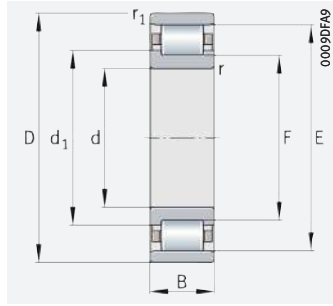

N

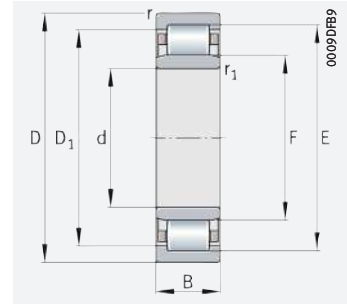

NU

d = 80 – 95 mm

Main dimensions			Basic load ratings		Fatigue limit load	Limiting speed	Speed rating	Mass	Designation
d	D	B	dyn. C_r	stat. C_{0r}	C_{ur}	n_G	$n_{\partial r}$	m	
			N	N	N	min^{-1}	min^{-1}	≈ kg	
80	125	22	91 000	99 000	12 900	9 400	5 000	0,99	NU1016-XL-M1
	140	26	166 000	168 000	29 000	6 100	4 200	1,55	N216-E-XL-TVP2
	140	26	166 000	168 000	22 600	6 100	4 200	1,55	NU216-E-XL-TVP2
	140	33	221 000	244 000	43 500	6 100	3 400	2,01	NU2216-E-XL-TVP2
	170	39	300 000	275 000	49 500	4 800	4 100	4,12	N316-E-XL-TVP2
	170	39	300 000	275 000	37 000	4 800	4 100	3,96	NU316-E-XL-TVP2
	170	58	420 000	425 000	79 000	4 800	3 450	5,89	NU2316-E-XL-TVP2
	200	48	395 000	365 000	46 000	5 400	3 750	8,37	NU416-XL-M1
85	130	22	93 000	103 000	13 400	9 000	4 750	1,04	NU1017-XL-M1
	150	28	194 000	194 000	33 500	5 600	4 000	1,92	N217-E-XL-TVP2
	150	28	194 000	194 000	26 000	5 600	4 000	1,91	NU217-E-XL-TVP2
	150	36	255 000	275 000	49 000	5 600	3 300	2,5	NU2217-E-XL-TVP2
	180	41	340 000	325 000	57 000	5 900	3 800	5,3	N317-E-XL-M1
	180	41	320 000	300 000	39 500	4 550	3 900	4,62	NU317-E-XL-TVP2
	180	60	435 000	445 000	81 000	4 550	3 300	6,72	NU2317-E-XL-TVP2
	210	52	420 000	385 000	48 000	5 200	3 850	9,85	NU417-XL-M1
90	140	24	111 000	124 000	16 200	8 400	4 550	1,36	NU1018-XL-M1
	160	30	215 000	217 000	37 000	5 200	3 900	2,37	N218-E-XL-TVP2
	160	30	215 000	217 000	28 500	5 200	3 900	2,36	NU218-E-XL-TVP2
	160	40	285 000	315 000	56 000	5 200	3 250	3,17	NU2218-E-XL-TVP2
	190	43	370 000	350 000	59 000	5 500	3 650	6,19	N318-E-XL-M1
	190	43	370 000	350 000	44 500	4 250	3 650	5,39	NU318-E-XL-TVP2
	190	64	510 000	530 000	93 000	4 250	3 000	8,04	NU2318-E-XL-TVP2
	225	54	465 000	425 000	53 000	4 800	3 500	11,8	NU418-XL-M1
95	145	24	113 000	130 000	16 800	8 100	4 350	1,42	NU1019-XL-M1
	170	32	260 000	265 000	44 500	4 850	3 650	2,89	N219-E-XL-TVP2
	170	32	260 000	265 000	34 500	4 850	3 650	2,88	NU219-E-XL-TVP2
	170	43	340 000	370 000	64 000	4 850	3 050	3,9	NU2219-E-XL-TVP2
	200	45	390 000	380 000	64 000	5 300	3 550	7,12	N319-E-XL-M1
	200	45	390 000	380 000	48 000	4 050	3 550	6,32	NU319-E-XL-TVP2
	200	67	540 000	580 000	100 000	4 050	2 800	9,4	NU2319-E-XL-TVP2
	240	55	495 000	470 000	57 000	4 550	3 200	13,9	NU419-XL-M1

medias ► <https://www.schaeffler.de/std/1DA3>

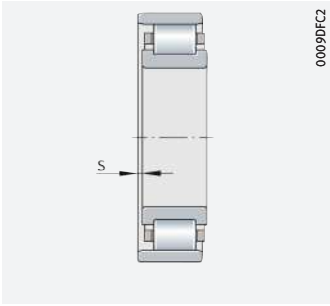

Axial displacement "s" for N and NU

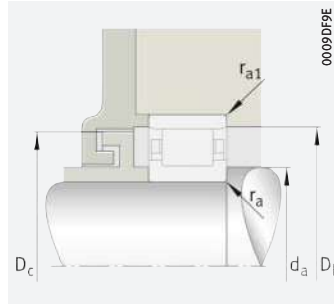

Mounting dimensions for N

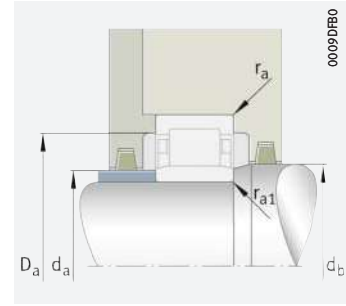

Mounting dimensions for NU

Dimensions

d	r	r ₁	s	E	F	D ₁	d ₁
	min.	min.				≈	≈
80	1,1	1	2,7	113,5	91,5	109,8	-
	2	2	1,2	127,3	95,3	-	101,5
	2	2	1,3	127,3	95,3	122,9	-
	2	2	1,3	127,3	95,3	122,9	-
	2,1	2,1	0,6	151	101	-	110,4
	2,1	2,1	0,7	151	101	143,9	-
	2,1	2,1	3,7	151	101	143,9	-
	3	3	4,6	170	110	159,7	-
85	1,1	1	4	118,5	96,5	114,8	-
	2	2	0,7	136,5	100,5	-	107,5
	2	2	0,8	136,5	100,5	131,5	-
	2	2	1,3	136,5	100,5	131,5	-
	3	3	1,1	160	108	-	117,8
	3	3	1,3	160	108	152,7	-
	3	3	4,7	160	108	152,7	-
	4	4	5,2	177	113	165,7	-
90	1,5	1,1	3	127	103	122,9	-
	2	2	1,4	145	107	-	114,3
	2	2	1,5	145	107	139,7	-
	2	2	2,5	145	107	139,7	-
	3	3	1,3	169,5	113,5	-	124
	3	3	1,5	169,5	113,5	161,6	-
	3	3	5	169,5	113,5	161,6	-
	4	4	5	191,5	123,5	179,7	-
95	1,5	1,1	3,1	132	108	127,9	-
	2,1	2,1	0,6	154,5	112,5	-	120,5
	2,1	2,1	0,7	154,5	112,5	148,6	-
	2,1	2,1	2,2	154,5	112,5	148,6	-
	3	3	1,4	177,5	121,5	-	132
	3	3	1,4	177,5	121,5	169,6	-
	3	3	5,6	177,5	121,5	169,6	-
	4	4	5,2	201,5	133,5	189,7	-

Mounting dimensions

d _a		d _b	D _a	D _b	D _c	r _a	r _{a1}	
min.	max.	min.	max.	min.	max.	max.	max.	
80	85	90	94	119	-	-	1	1
	91	-	-	129	129	126	2	2
	91	94	97	129	-	-	2	2
	91	94	97	129	-	-	2	2
	92	-	-	158	153	149	2,1	2,1
	92	99	105	158	-	-	2,1	2,1
	92	99	105	158	-	-	2,1	2,1
	96	109	112	184	-	-	2,5	2,5
85	90	95	99	124	-	-	1	1
	96	-	-	139	138	135	2	2
	96	99	104	139	-	-	2	2
	96	99	104	139	-	-	2	2
	99	-	-	166	162	158	2,5	2,5
	99	106	110	166	-	-	2,5	2,5
	99	106	110	166	-	-	2,5	2,5
	105	111	115	190	-	-	3	3
90	96	101	106	133	-	-	1,5	1
	101	-	-	149	147	143	2	2
	101	105	109	149	-	-	2	2
	101	105	109	149	-	-	2	2
	104	-	-	176	171	168	2,5	2,5
	104	111	117	176	-	-	2,5	2,5
	104	111	117	176	-	-	2,5	2,5
	110	122	125	205	-	-	3	3
95	101	106	111	138	-	-	1,5	1
	107	-	-	158	156	153	2,1	2,1
	107	111	116	158	-	-	2,1	2,1
	107	111	116	158	-	-	2,1	2,1
	109	-	-	186	179	176	2,5	2,5
	109	119	124	186	-	-	2,5	2,5
	109	119	124	186	-	-	2,5	2,5
	115	132	136	220	-	-	3	3



Cylindrical roller bearings with cage

Non-locating bearings

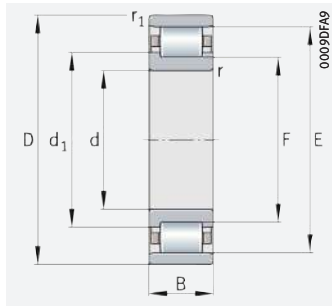

N

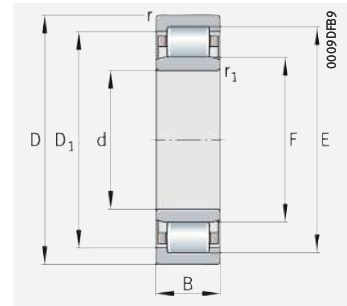

NU

d = 100 – 130 mm

Main dimensions			Basic load ratings		Fatigue limit load	Limiting speed	Speed rating	Mass	Designation
d	D	B	dyn. C_r	stat. C_{0r}	C_{ur}	n_G	$n_{\theta r}$	m	▶ 425 1.12 ▶ 426 1.13 X-life ▶ 415
			N	N	N	min ⁻¹	min ⁻¹	≈ kg	
100	150	24	116 000	135 000	17 300	7 800	4 150	1,46	NU1020-XL-M1
	180	34	295 000	305 000	51 000	4 550	3 450	3,5	N220-E-XL-TVP2
	180	34	295 000	305 000	39 500	4 550	3 450	3,49	NU220-E-XL-TVP2
	180	46	395 000	445 000	77 000	4 550	2 900	4,77	NU2220-E-XL-TVP2
	215	47	450 000	425 000	71 000	4 850	3 350	8,75	N320-E-XL-M1
	215	47	450 000	425 000	53 000	3 700	3 350	7,67	NU320-E-XL-TVP2
	215	73	680 000	720 000	124 000	3 700	2 500	12,1	NU2320-E-XL-TVP2
250	58	550 000	530 000	63 000	4 350	2 950	15,8	NU420-XL-M1	
105	160	26	132 000	154 000	19 500	7 300	4 050	1,84	NU1021-XL-M1
	190	36	310 000	320 000	53 000	5 600	3 400	4,63	N221-E-XL-M1
	190	36	310 000	320 000	40 500	4 350	3 400	4,08	NU221-E-XL-TVP2
	260	60	610 000	590 000	70 000	4 150	2 750	17,7	NU421-XL-M1
110	170	28	167 000	191 000	24 400	6 700	3 850	2,31	NU1022-XL-M1
	200	38	345 000	365 000	46 000	4 100	3 250	4,84	NU222-E-XL-TVP2
	200	38	345 000	365 000	59 000	4 100	3 250	4,85	N222-E-XL-TVP2
	200	53	455 000	520 000	87 000	4 100	2 750	6,76	NU2222-E-XL-TVP2
	240	50	495 000	475 000	58 000	3 350	3 050	10,3	NU322-E-XL-TVP2
	240	50	520 000	510 000	85 000	4 350	2 950	11,7	N322-E-XL-M1
	240	80	750 000	800 000	137 000	3 350	2 290	16,6	NU2322-E-XL-TVP2
	280	65	680 000	660 000	78 000	3 850	2 550	22,4	NU422-XL-M1
120	180	28	175 000	208 000	26 000	6 400	3 550	2,47	NU1024-XL-M1
	215	40	390 000	415 000	68 000	3 750	3 050	5,67	N224-E-XL-TVP2
	215	40	390 000	415 000	52 000	3 750	3 050	5,8	NU224-E-XL-TVP2
	215	58	530 000	610 000	104 000	3 750	2 500	8,38	NU2224-E-XL-TVP2
	260	55	610 000	600 000	71 000	3 050	2 650	13,3	NU324-E-XL-TVP2
	260	55	610 000	600 000	95 000	3 950	2 650	15,3	N324-E-XL-M1
	260	86	930 000	1 010 000	167 000	3 950	1 980	23,5	NU2324-E-XL-M1
310	72	850 000	840 000	97 000	3 450	2 200	30,8	NU424-XL-M1	
130	200	33	212 000	250 000	31 500	5 700	3 500	3,74	NU1026-XL-M1
	230	40	425 000	445 000	54 000	3 500	2 800	6,5	NU226-E-XL-TVP2
	230	40	425 000	445 000	70 000	3 500	2 800	6,51	N226-E-XL-TVP2
	230	64	620 000	730 000	119 000	3 500	2 280	10,4	NU2226-E-XL-TVP2
	280	58	680 000	670 000	79 000	2 850	2 430	16,2	NU326-E-XL-TVP2
	280	58	720 000	720 000	113 000	3 700	2 340	18,4	N326-E-XL-M1
	280	93	1 080 000	1 220 000	197 000	3 700	1 750	28,8	NU2326-E-XL-M1

medias ▶ <https://www.schaeffler.de/std/1DA4>

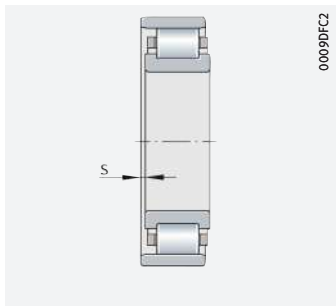

Axial displacement "s" for N and NU

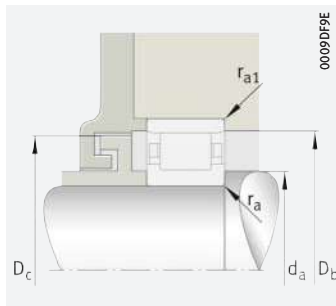

Mounting dimensions for N

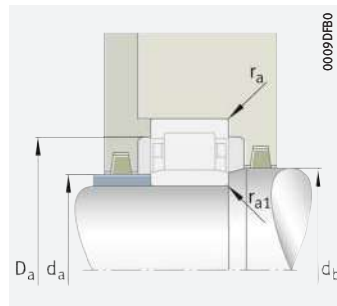

Mounting dimensions for NU

Dimensions								Mounting dimensions								
d	r	r ₁	s	E	F	D ₁	d ₁	d _a		d _b		D _a	D _b	D _c	r _a	r _{a1}
								min.	max.	min.	max.					
100	1,5	1,1	2,9	137	113	132,9	–	106	111	116	143	–	–	1,5	1	
	2,1	2,1	1,4	163	119	–	127,3	112	–	–	168	165	161	2,1	2,1	
	2,1	2,1	1,5	163	119	156,9	–	112	117	122	168	–	–	2,1	2,1	
	2,1	2,1	2,5	163	119	156,9	–	112	117	122	168	–	–	2,1	2,1	
	3	3	1,2	191,5	127,5	–	139,4	114	–	–	201	193	190	2,5	2,5	
	3	3	1,2	191,5	127,5	182	–	114	125	132	201	–	–	2,5	2,5	
	3	3	4,2	191,5	127,5	182	–	114	125	132	201	–	–	2,5	2,5	
	4	4	5,7	211	139	198,2	–	120	137	141	230	–	–	3	3	
105	2	1,1	4,5	145,5	119,5	141	–	111	118	122	151	–	–	2	1	
	2,1	2,1	1,2	171,5	125,5	–	134,5	117	–	–	178	173	170	2,1	2,1	
	2,1	2,1	1,3	171,5	125,5	165,1	–	117	123	128	178	–	–	2,1	2,1	
	4	4	5,7	220,5	144,5	207,4	–	125	143	147	240	–	–	3	3	
110	2	1,1	3,2	155	125	–	149,7	116	124	128	161	–	–	2	1	
	2,1	2,1	1,5	180,5	132,5	–	173,8	122	130	135	188	–	–	2,1	2,1	
	2,1	2,1	1,4	180,5	132,5	141,6	–	122	–	–	188	182	179	2	2	
	2,1	2,1	4	180,5	132,5	–	173,8	122	130	135	188	–	–	2,1	2,1	
	3	3	1,3	211	143	–	200,9	124	140	145	226	–	–	2,5	2,5	
	3	3	1,3	211	143	155,6	–	124	–	–	226	213	209	2,5	2,5	
	3	3	5,8	211	143	–	200,9	124	140	145	226	–	–	2,5	2,5	
	4	4	6,2	235	155	–	220,9	130	153	157	260	–	–	3	3	
120	2	1,1	3,2	165	135	–	159,7	126	134	138	171	–	–	2	1	
	2,1	2,1	1,4	195,5	143,5	153,2	–	132	–	–	203	197	194	2,1	2,1	
	2,1	2,1	1,4	195,5	143,5	–	187,8	132	141	146	203	–	–	2,1	2,1	
	2,1	2,1	4,5	195,5	143,5	–	187,8	132	141	146	203	–	–	2,1	2,1	
	3	3	3,5	230	154	–	218,7	134	151	156	246	–	–	2,5	2,5	
	3	3	3,5	230	154	168,7	–	134	–	–	246	232	228	2,5	2,5	
	3	3	7,2	230	154	–	218,7	134	151	156	246	–	–	2,5	2,5	
	5	5	6,9	260	170	–	243,9	144	168	172	286	–	–	4	4	
130	2	1,1	3,9	182	148	–	175,9	136	146	151	191	–	–	2	1	
	3	3	1,2	209,5	153,5	–	201,2	144	151	158	216	–	–	2,5	2,5	
	3	3	1,2	209,5	153,5	164	–	144	–	–	216	212	207	2,5	2,5	
	3	3	5,2	209,5	153,5	–	201,2	144	151	158	216	–	–	2,5	2,5	
	4	4	3,5	247	167	–	235,2	147	164	169	263	–	–	3	3	
	4	4	3,5	247	167	181,7	–	147	–	–	263	249	245	3	3	
	4	4	8,1	247	167	–	235,2	147	164	169	263	–	–	3	3	



Cylindrical roller bearings with cage

Non-locating bearings

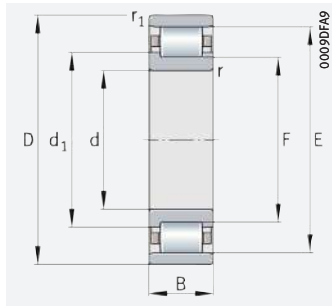

N

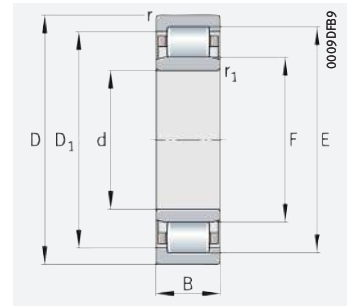

NU

d = 140 – 180 mm

Main dimensions			Basic load ratings		Fatigue limit load	Limiting speed	Speed rating	Mass	Designation
d	D	B	dyn. C _r	stat. C _{0r}	C _{ur}	n _G	n _{θr}	m	▶ 425 1.12 ▶ 426 1.13 X-life ▶ 415
			N	N	N	min ⁻¹	min ⁻¹	≈ kg	
140	210	33	216 000	265 000	32 500	5 400	3 250	3,94	NU1028-XL-M1
	250	42	460 000	510 000	77 000	4 250	2 600	9,3	N228-E-XL-M1
	250	42	460 000	510 000	60 000	4 250	2 600	9,31	NU228-E-XL-M1
	250	68	670 000	830 000	132 000	4 250	2 050	14,5	NU2228-E-XL-M1
	300	62	790 000	800 000	124 000	3 450	2 170	22,5	N328-E-XL-M1
	300	62	790 000	800 000	92 000	2 650	2 170	20,1	NU328-E-XL-TVP2
	300	102	1 210 000	1 390 000	220 000	3 450	1 620	36	NU2328-E-XL-M1
150	225	35	248 000	310 000	38 000	5 100	3 100	4,93	NU1030-XL-M1
	270	45	520 000	590 000	89 000	3 950	2 350	11,8	N230-E-XL-M1
	270	45	520 000	590 000	68 000	3 950	2 350	11,9	NU230-E-XL-M1
	270	73	780 000	970 000	153 000	3 950	1 850	18,6	NU2230-E-XL-M1
	320	65	900 000	930 000	138 000	3 200	1 940	26,9	N330-E-XL-M1
	320	65	900 000	930 000	105 000	3 200	1 940	27	NU330-E-XL-M1
	320	108	1 380 000	1 600 000	247 000	3 200	1 460	43,4	NU2330-E-XL-M1
160	240	38	290 000	355 000	43 000	4 650	3 000	5,92	NU1032-XL-M1
	290	48	590 000	670 000	101 000	3 650	2 160	14,7	N232-E-XL-M1
	290	48	590 000	670 000	79 000	3 650	2 160	14,7	NU232-E-XL-M1
	290	80	940 000	1 170 000	186 000	3 600	1 660	23,7	NU2232-E-XL-M1
	340	68	860 000	1 060 000	128 000	3 000	1 770	32,6	N332-E-M1
	340	68	860 000	1 060 000	92 000	3 000	1 770	31,8	NU332-E-M1
	340	114	1 300 000	1 800 000	227 000	3 000	1 350	51,5	NU2332-E-M1
170	260	42	350 000	435 000	51 000	4 300	2 750	8,03	NU1034-XL-M1
	310	52	700 000	780 000	116 000	3 350	1 970	18	N234-E-XL-M1
	310	52	700 000	780 000	91 000	3 350	1 970	18,1	NU234-E-XL-M1
	310	86	1 130 000	1 400 000	215 000	3 300	1 470	29,4	NU2234-E-XL-M1
	360	72	960 000	1 210 000	138 000	2 800	1 610	37,9	N334-E-TB-M1
	360	72	960 000	1 210 000	95 000	2 800	1 610	38	NU334-E-TB-M1
	360	120	1 490 000	2 070 000	228 000	2 800	1 210	61,4	NU2334-EX-TB-M1
180	280	46	425 000	520 000	62 000	3 900	2 550	10,5	NU1036-XL-M1
	320	52	730 000	830 000	122 000	3 250	1 850	18,9	N236-E-XL-M1
	320	52	730 000	830 000	95 000	3 250	1 850	18,9	NU236-E-XL-M1
	320	86	1 180 000	1 490 000	226 000	3 200	1 380	30,7	NU2236-E-XL-M1
	380	75	1 040 000	1 320 000	100 000	2 650	1 500	43,9	NU336-E-TB-M1
	380	126	1 680 000	2 330 000	255 000	2 600	1 120	71,8	NU2336-EX-TB-M1

medias ▶ <https://www.schaeffler.de/std/1DA5>

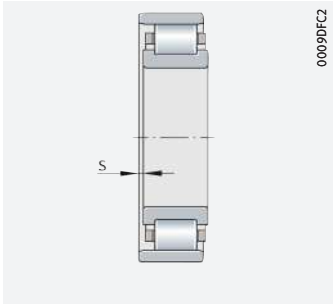

Axial displacement "s" for N and NU

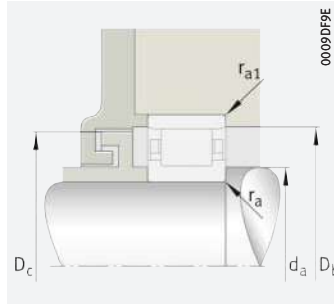

Mounting dimensions for N

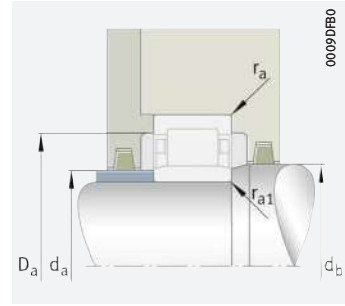

Mounting dimensions for NU

Dimensions

d	r	r ₁	s	E	F	D ₁	d ₁
140	2	1,1	3,8	192	158	185,9	-
	3	3	3,8	225	169	-	179,4
	3	3	3,8	225	169	216,7	-
	3	3	7	225	169	216,7	-
	4	4	5,2	264	180	-	195,4
	4	4	5,2	264	180	251,7	-
	4	4	9,2	264	180	251,7	-
150	2,1	1,5	4,2	205,5	169,5	199	-
	3	3	4	242	182	-	193,1
	3	3	4	242	182	233,2	-
	3	3	7,5	242	182	233,2	-
	4	4	5,5	283	193	-	209,5
	4	4	5,5	283	193	269,8	-
	4	4	9,7	283	193	269,8	-
160	2,1	1,5	4,3	220	180	212,9	-
	3	3	4,1	259	195	-	206,8
	3	3	4,1	259	195	249,6	-
	3	3	7,2	261	193	251,1	-
	4	4	5,5	300	204	-	221,6
	4	4	5,6	300	204	286	-
	4	4	9,9	300	204	286	-
170	2,1	2,1	4,8	237	193	229,1	-
	4	4	4,3	279	207	-	218,4
	4	4	4,3	279	207	268,5	-
	4	4	7,2	281	205	269,9	-
	4	4	5,9	318	218	-	238
	4	4	6	318	218	298	-
	4	4	10,2	320	216	299,2	-
180	2,1	2,1	5	255	205	245,9	-
	4	4	4,7	289	217	-	230,2
	4	4	4,7	289	217	278,6	-
	4	4	7,2	291	215	280	-
	4	4	6,1	335	231	314,2	-
	4	4	10,5	339	227	316,6	-

Mounting dimensions

d _a	d _b	D _a	D _b	D _c	r _a	r _{a1}		
							min.	max.
140	146	156	161	201	-	-	2	1
	154	-	-	236	227	223	2,5	2,5
	154	166	171	236	-	-	2,5	2,5
	154	166	171	236	-	-	2,5	2,5
	157	-	-	283	266	262	3	3
	157	176	182	283	-	-	3	3
	157	176	182	283	-	-	3	3
150	158	167	173	215	-	-	2,1	1,5
	164	-	-	256	244	240	2,5	2,5
	164	179	184	256	-	-	2,5	2,5
	164	179	184	256	-	-	2,5	2,5
	167	-	-	303	285	281	3	3
	167	190	195	303	-	-	3	3
	167	190	195	303	-	-	3	3
160	168	178	184	230	-	-	2,1	1,5
	174	-	-	276	261	257	2,5	2,5
	174	192	197	276	-	-	2,5	2,5
	174	192	197	276	-	-	2,5	2,5
	177	-	-	323	302	298	3	3
	177	200	211	323	-	-	3	3
	177	200	211	323	-	-	3	3
170	180	190	197	250	-	-	2,1	2,1
	187	-	-	293	281	277	3	3
	187	204	211	293	-	-	3	3
	187	204	211	293	-	-	3	3
	187	-	-	343	320	316	3	3
	187	215	221	343	-	-	3	3
	187	214	218	343	-	-	3	3
180	190	203	209	270	-	-	2,1	2,1
	197	-	-	303	292	286	3	3
	197	214	221	303	-	-	3	3
	197	214	221	303	-	-	3	3
	197	228	234	363	-	-	3	3
	197	225	229	363	-	-	3	3



Cylindrical roller bearings with cage

Non-locating bearings

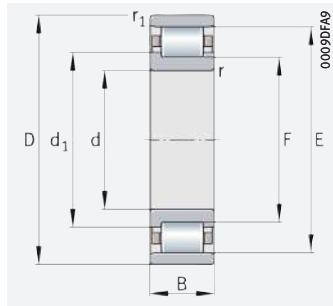

N

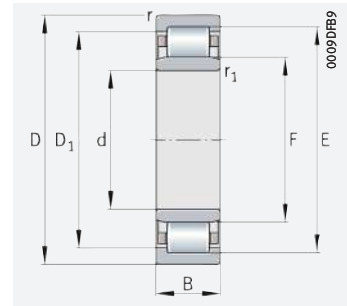

NU

d = 190 – 280 mm

Main dimensions			Basic load ratings		Fatigue limit load	Limiting speed	Speed rating	Mass	Designation
d	D	B	dyn. C_r	stat. C_{0r}	C_{ur}	n_G	$n_{\theta r}$	m	▶ 425 1.12 ▶ 426 1.13 X-life ▶ 415
			N	N	N	min ⁻¹	min ⁻¹	≈ kg	
190	290	46	435 000	550 000	64 000	3 800	2 410	10,9	NU1038-XL-M1
	340	55	680 000	930 000	111 000	3 050	1 720	22,8	N238-E-M1
	340	55	680 000	930 000	81 000	3 050	1 720	22,8	NU238-E-M1
	340	92	1 090 000	1 650 000	202 000	3 000	1 290	37,1	NU2238-E-M1
	400	78	1 120 000	1 440 000	107 000	2 550	1 400	50,6	NU338-E-TB-M1
	400	132	1 890 000	2 650 000	290 000	2 440	1 010	83,1	NU2338-EX-TB-M1
200	310	51	470 000	600 000	70 000	3 550	2 310	14,1	NU1040-XL-M1
	360	58	750 000	1 040 000	121 000	2 900	1 600	27,2	N240-E-M1
	360	58	750 000	1 040 000	90 000	2 900	1 600	27,2	NU240-E-M1
	360	98	1 220 000	1 880 000	227 000	2 850	1 180	44,7	NU2240-E-M1
	420	80	1 180 000	1 520 000	114 000	2 410	1 320	57,3	NU340-E-TB-M1
	420	138	2 040 000	2 900 000	310 000	2 330	940	95,6	NU2340-EX-TB-M1
220	340	56	510 000	770 000	68 000	3 150	2 040	20,5	NU1044-M1
	400	65	950 000	1 330 000	104 000	2 600	1 380	38,1	NU244-E-M1
	400	108	1 630 000	2 370 000	250 000	2 440	1 000	61,6	NU2244-EX-TB-M1
	460	88	1 440 000	1 890 000	134 000	2 170	1 140	75,5	NU344-E-TB-M1
	460	145	2 350 000	3 350 000	345 000	2 110	830	121	NU2344-EX-TB-M1
	240	360	56	540 000	840 000	73 000	3 000	1 850	19,9
440		72	1 160 000	1 650 000	172 000	2 320	1 210	51,5	N248-E-TB-M1
440		72	1 140 000	1 610 000	122 000	2 320	1 220	51,8	NU248-E-TB-M1
440		120	1 850 000	2 800 000	290 000	2 250	900	82,8	NU2248-EX-TB-M1
500		95	1 720 000	2 280 000	158 000	1 980	1 000	95,7	NU348-E-TB-M1
500		155	2 600 000	3 750 000	370 000	1 940	750	151	NU2348-EX-TB-M1
260	400	65	650 000	1 010 000	88 000	2 700	1 690	29,7	NU1052-M1
	480	80	1 350 000	1 890 000	139 000	2 100	1 110	68,4	NU252-E-TB-M1
	480	130	2 180 000	3 350 000	345 000	2 060	780	109	NU2252-E-TB-M1
	540	102	1 910 000	2 600 000	182 000	1 840	900	121	NU352-E-TB-M1
	540	165	3 100 000	4 500 000	445 000	1 780	660	189	NU2352-EX-TB-M1
280	420	65	680 000	1 100 000	94 000	2 550	1 550	31,4	NU1056-M1
	500	80	1 400 000	2 020 000	147 000	2 020	1 020	72,1	NU256-E-TB-M1
	500	130	2 270 000	3 600 000	365 000	1 980	720	114	NU2256-E-TB-M1
	580	108	2 180 000	3 050 000	200 000	1 700	790	147	NU356-E-TB-M1
	580	175	3 500 000	5 200 000	495 000	1 640	590	234	NU2356-EX-TB-M1

medias ▶ <https://www.schaeffler.de/std/1DA6>

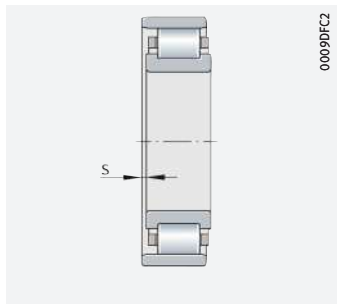

Axial displacement "s" for N and NU

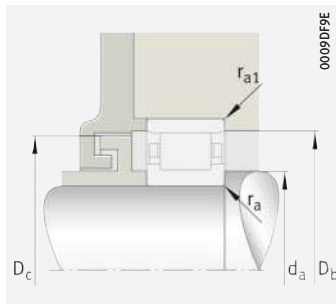

Mounting dimensions for N

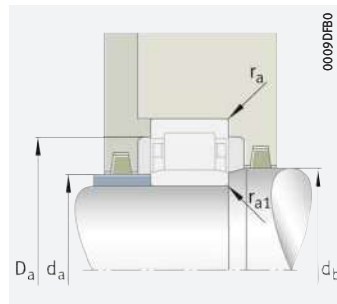

Mounting dimensions for NU

Dimensions

d	r	r ₁	s	E	F	D ₁	d ₁
190	2,1	2,1	5	265	215	255,9	–
	4	4	4,7	306	230	–	244
	4	4	4,7	306	230	295	–
	4	4	8	308	228	296,4	–
	5	5	6,3	353	245	331,4	–
	5	5	11	360	240	336	–
200	2,1	2,1	8,3	281	229	271,5	–
	4	4	4,8	323	243	–	257,6
	4	4	4,8	323	243	311,5	–
	4	4	8,2	325	241	312,9	–
	5	5	6,3	370	258	347,6	–
	5	5	11,3	377	253	352,2	–
220	3	3	6,2	310	250	298,9	–
	4	4	5,5	358	268	344,9	–
	4	4	8,4	367	259	345,4	–
	5	5	7	406	282	381,2	–
	5	5	11,9	413	277	385,8	–
	240	3	3	6,4	330	270	318,9
4		4	6	393	293	–	313
4		4	6	393	293	373	–
4		4	10,2	399	287	376,6	–
5		5	7,4	442	306	414,8	–
5		5	13,3	447	303	418,2	–
260	4	4	7,2	364	296	351,3	–
	5	5	6,2	429	317	406,6	–
	5	5	10,5	433	313	409	–
	6	6	10	477	337	449	–
	6	6	13,7	484	324	452	–
	280	4	4	7,2	384	316	371,3
5		5	6,3	449	337	426,6	–
5		5	10,5	453	333	429	–
6		6	8,7	512	362	482	–
6		6	13,8	521	351	487	–

Mounting dimensions

d _a	d _b	D _a	D _b	D _c	r _a	r _{a1}	
							min.
200	213	219	280	–	–	2,1	2,1
207	–	–	323	309	303	3	3
207	227	234	323	–	–	3	3
207	227	234	323	–	–	3	3
210	242	248	380	–	–	4	4
210	237,8	242,2	380	–	–	4	4
210	226	233	300	–	–	2,1	2,1
217	–	–	343	326	320	3	3
217	240	247	343	–	–	3	3
217	240	247	343	–	–	3	3
220	255	261	400	–	–	4	4
220	250,7	255,3	400	–	–	4	4
232	248	254	328	–	–	2,5	2,5
237	265	271	383	–	–	3	3
237	256,7	261,3	383	–	–	3	3
240	279	285	440	–	–	4	4
240	274,7	279,3	440	–	–	4	4
252	268	275	348	–	–	2,5	2,5
257	–	–	423	396	390	3	3
257	290	296	423	–	–	3	3
257	284,5	289,5	423	–	–	3	3
260	303	309	480	–	–	4	4
260	300,5	305,5	480	–	–	4	4
275	292	300	385	–	–	3	3
280	314	320	460	–	–	4	4
280	310	316	460	–	–	4	4
286	334,3	339,7	514	–	–	5	5
286	321,3	326,7	514	–	–	5	5
295	312	321	405	–	–	3	3
300	334	340	480	–	–	4	4
300	330	336	480	–	–	4	4
306	359	366	554	–	–	5	5
306	348	354	554	–	–	5	5





Cylindrical roller bearings with cage

Non-locating bearings

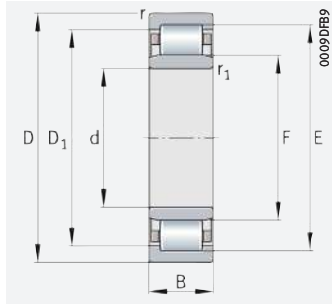

NU

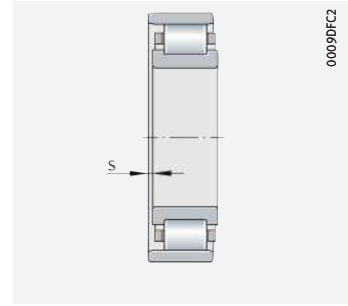

Axial displacement "s" for NU

d = 300 – 710 mm

Main dimensions			Basic load ratings		Fatigue limit load C_{ur} N	Limiting speed n_G min ⁻¹	Speed rating $n_{\theta r}$ min ⁻¹	Mass m ≈ kg	Designation ➤ 425 1.12 ➤ 426 1.13
d	D	B	dyn. C_r N	stat. C_{0r} N					
300	460	74	900 000	1 430 000	119 000	2 290	1 390	44,6	NU1060-M1
	540	85	1 600 000	2 330 000	166 000	1 860	920	90,4	NU260-E-TB-M1
	540	140	2 700 000	4 100 000	410 000	1 780	650	143	NU2260-EX-TB-M1
320	480	74	910 000	1 490 000	122 000	2 200	1 300	46,9	NU1064-M1
	580	92	1 810 000	2 700 000	185 000	1 730	830	113	NU264-EX-TB-M1
	580	150	3 150 000	4 900 000	460 000	1 650	570	180	NU2264-EX-TB-M1
340	520	82	1 120 000	1 830 000	146 000	2 010	1 190	63,2	NU1068-M1
360	540	82	1 150 000	1 910 000	151 000	1 940	1 110	65,9	NU1072-M1
	650	170	3 600 000	5 800 000	530 000	1 490	510	254	NU2272-E-TB-M1
380	560	82	1 170 000	1 990 000	156 000	1 880	1 050	69,1	NU1076-M1
	680	175	4 050 000	6 700 000	610 000	1 420	450	288	NU2276-E-TB-M1
400	600	90	1 380 000	2 330 000	174 000	1 730	980	90,1	NU1080-TB-M1
420	620	90	1 410 000	2 430 000	180 000	1 680	920	92,9	NU1084-TB-M1
440	650	94	1 560 000	2 750 000	197 000	1 600	860	107	NU1088-TB-M1
460	620	74	1 020 000	1 970 000	153 000	1 770	860	63,1	NU1992-M1
	680	100	1 680 000	2 950 000	212 000	1 530	830	125	NU1092-TB-M1
480	650	78	1 150 000	2 250 000	175 000	1 680	810	74,2	NU1996-M1
	700	100	1 720 000	3 100 000	220 000	1 490	780	129	NU1096-TB-M1
500	720	100	1 750 000	3 200 000	227 000	1 450	750	133	NU10/500-TB-M1
560	750	85	1 460 000	2 950 000	222 000	1 450	660	105	NU19/560-M1
	820	115	2 700 000	5 100 000	325 000	1 250	590	213	NU10/560-TB-M1
600	800	90	1 960 000	3 900 000	265 000	1 300	570	125,3	NU19/600-E-TB-M1
670	900	103	2 040 000	4 250 000	290 000	1 190	530	186	NU19/670-TB-M1
710	950	106	2 230 000	4 750 000	325 000	1 130	485	213	NU19/710-TB-M1

medias ➤ <https://www.schaeffler.de/std/1DA7>

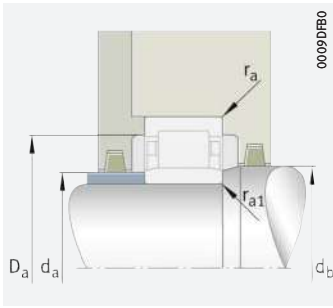

Mounting dimensions for NU

Dimensions							Mounting dimensions					
d	r	r ₁	s	E	F	D ₁	d _a		d _b	D _a	r _a	r _{a1}
							min.	max.				
300	4	4	7,9	420	340	405,2	315	336	345	445	3	3
	5	5	6,9	484	364	460	320	359	367	520	4	4
	5	5	12,2	495	355	467	320	352	358	520	4	4
320	4	4	11,5	440	360	425,1	335	356	365	465	3	3
	5	5	7,5	520	392	494,4	340	388,5	395,5	560	4	4
	5	5	11,9	530	380	500	340	376,5	383,5	560	4	4
340	5	5	12,5	475	385	458,2	357	381	390	503	4	4
360	5	5	12,5	495	405	478,1	377	400	410	523	4	4
	6	6	15	588	428	556	386	424	432	624	5	5
380	5	5	9	515	425	498,1	397	420	430	543	4	4
	6	6	13,8	615	451	582,2	406	446	456	654	5	5
400	5	5	9,5	550	450	530	417	445	455	583	4	4
420	5	5	9,6	570	470	550	437	465	475	603	4	4
440	6	6	9,8	597	493	576,2	463	488	498	627	5	5
460	4	4	8,4	578	502	562,8	475	498	506	605	3	3
	6	6	11,2	624	516	602,4	483	510	522	657	5	5
480	5	5	6,8	605	525	589	497	521	529	633	4	4
	6	6	10,7	644	536	622,4	503	530	542	677	5	5
500	6	6	10,7	664	556	642,4	523	550	562	697	5	5
560	5	5	9,6	700	610	682	577	606	614	733	4	4
	6	6	9,8	754	626	728,4	583	620	632	797	5	5
600	5	5	9,9	748	652	735,4	617	647	657	783	4	4
670	6	6	11,3	839	731	817	693	726	736	877	5	5
710	6	6	9,3	886	774	863,6	733	769	779	927	5	5





Cylindrical roller bearings with cage

Semi-locating bearings, locating bearings

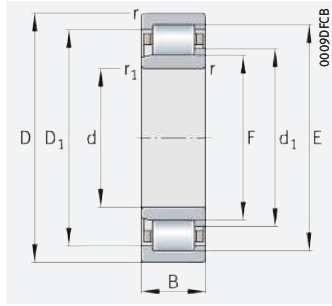

NJ
Semi-locating bearing

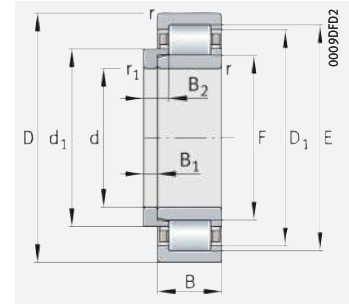

NJ and HJ
Locating bearings

d = 15 – 20 mm

Main dimensions			Basic load ratings		Fatigue limit load C_{ur} N	Limiting speed n_G min^{-1}	Speed rating n_{dr} min^{-1}	Mass m		Designation	
d	D	B	dyn. C_r N	stat. C_{Or} N				Bearing \approx kg	L-section ring \approx kg	Bearing	L-section ring
15	35	11	15 100	10 400	1 600	27 000	17 900	0,049	–	NJ202-E-XL-TVP2	–
	35	11	15 100	10 400	1 600	27 000	17 900	0,049	0,005	NJ202-E-XL-TVP2	HJ202-E
17	40	12	20 800	14 600	2 180	22 900	15 300	0,07	–	NJ203-E-XL-TVP2	–
	40	12	20 800	14 600	2 180	22 900	15 300	0,07	0,008	NJ203-E-XL-TVP2	HJ203-E
	40	12	20 800	14 600	2 190	22 900	15 300	0,073	–	NUP203-E-XL-TVP2	–
	40	16	28 500	21 900	3 450	22 900	13 200	0,053	–	NJ2203-E-XL-TVP2	–
	40	16	28 500	21 900	3 450	22 900	13 200	0,053	0,008	NJ2203-E-XL-TVP2	HJ2203-E
	40	16	28 500	21 900	3 500	22 900	13 200	0,055	–	NUP2203-E-XL-TVP2	–
	47	14	30 000	21 200	3 350	19 600	13 500	0,124	–	NJ303-E-XL-TVP2	–
	47	14	30 000	21 200	3 350	19 600	13 500	0,124	0,014	NJ303-E-XL-TVP2	HJ303-E
	47	14	30 000	21 200	3 350	19 600	13 500	0,142	–	NUP303-E-XL-TVP2	–
20	47	14	32 500	24 700	3 900	19 200	12 800	0,117	–	NJ204-E-XL-TVP2	–
	47	14	32 500	24 700	3 900	19 200	12 800	0,117	0,011	NJ204-E-XL-TVP2	HJ204-E
	47	14	32 500	24 700	3 900	19 200	12 800	0,119	–	NUP204-E-XL-TVP2	–
	47	18	38 500	31 000	5 100	19 200	11 100	0,15	–	NJ2204-E-XL-TVP2	–
	47	18	38 500	31 000	5 100	19 200	11 100	0,15	0,012	NJ2204-E-XL-TVP2	HJ2204-E
	47	18	38 500	31 000	5 100	19 200	11 100	0,154	–	NUP2204-E-XL-TVP2	–
	52	15	37 500	27 000	3 850	17 200	11 900	0,156	–	NJ304-E-XL-TVP2	–
	52	15	37 500	27 000	3 850	17 200	11 900	0,156	0,017	NJ304-E-XL-TVP2	HJ304-E
	52	15	37 500	27 000	3 850	17 200	11 900	0,16	–	NUP304-E-XL-TVP2	–
	52	21	49 500	39 000	6 100	17 200	9 700	0,219	–	NJ2304-E-XL-TVP2	–
	52	21	49 500	39 000	6 100	17 200	9 700	0,219	0,019	NJ2304-E-XL-TVP2	HJ2304-E
52	21	49 500	39 000	6 200	17 200	9 700	0,224	–	NUP2304-E-XL-TVP2	–	

medias ► <https://www.schaeffler.de/std/1DA8>

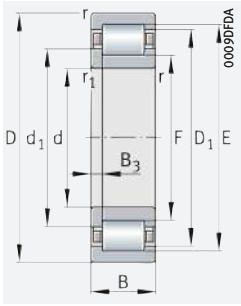

NUP
Locating bearing

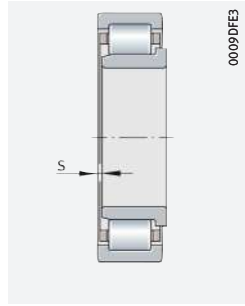

Axial displacement "s"
for NJ

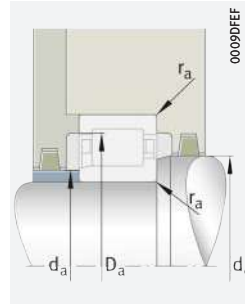

Mounting dimensions
for NJ

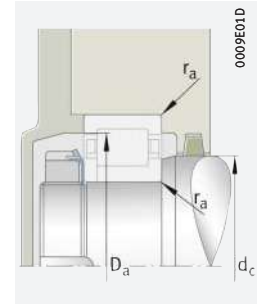

Mounting dimensions
for NUP

Dimensions

Mounting dimensions

d	r	r ₁	s	E	F	D ₁	d ₁	B ₁	B ₂	B ₃	Mounting dimensions				
											d _a		d _c	D _a	r _a
											min. ¹⁾	max.			
15	0,6	0,3	1,6	30,3	19,3	28	21,6	-	-	-	17,4	18,5	22	32,6	0,6
	0,6	0,3	-	30,3	19,3	28	21,6	2,5	5	-	17,4	-	22	32,6	0,6
17	0,6	0,3	1,2	35,1	22,1	32,5	24,7	-	-	-	21	21,5	28	36	0,6
	0,6	0,3	-	35,1	22,1	32,5	24,7	3	5,5	-	21	-	28	36	0,6
	0,6	0,3	-	35,1	22,1	32,5	24,7	-	-	2,5	21	-	28	36	0,6
	0,6	0,3	1,7	35,1	22,1	32,5	24,7	-	-	-	21	21,5	26	36	0,6
	0,6	0,3	-	35,1	22,1	32,5	24,7	3	6	-	21	-	26	36	0,6
	0,6	0,6	-	35,1	22,1	32,5	24,7	-	-	3	21	-	26	36	0,6
	1	0,6	1,2	40,2	24,2	37,1	27,6	-	-	-	21,2	23,5	28	42,8	1
	1	0,6	-	40,2	24,2	37,1	27,6	4	6,5	-	21,2	-	28	42,8	1
20	1	0,6	-	40,2	24,2	37,1	27,6	-	-	2,5	21,2	-	28	42,8	1
	1	0,6	1	41,5	26,5	38,8	29,7	-	-	-	24	26	32	41	1
	1	0,6	-	41,5	26,5	38,8	29,7	3	5,5	-	24	-	32	41	1
	1	0,6	-	41,5	26,5	38,8	29,7	-	-	2,5	24	-	32	41	1
	1	0,6	1,8	41,5	26,5	38,8	29,7	-	-	-	24	26	32	41	1
	1	0,6	-	41,5	26,5	38,8	29,7	3	6,5	-	24	-	32	41	1
	1	0,6	-	41,5	26,5	38,8	29,7	-	-	3,5	24	-	32	41	1
	1,1	0,6	1	45,5	27,5	42,4	31,3	-	-	-	24	27	33	45	1
	1,1	0,6	-	45,5	27,5	42,4	31,3	4	6,5	-	24	-	33	45	1
	1,1	0,6	-	45,5	27,5	42,4	31,3	-	-	2,5	24	-	33	45	1
	1,1	0,6	1,9	45,5	27,5	42,4	31,3	-	-	-	24	27	33	45	1
1,1	0,6	-	45,5	27,5	42,4	31,3	4	7,5	-	24	-	33	45	1	
1,1	0,6	-	45,5	27,5	42,4	31,3	-	-	3,5	24	-	33	45	1	

¹⁾ Under axial load, observe the dimensions D₁ and d₁.





Cylindrical roller bearings with cage

Semi-locating bearings, locating bearings

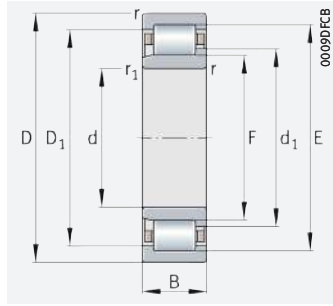

NJ
Semi-locating bearing

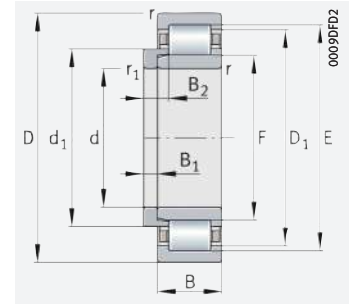

NJ and HJ
Locating bearings

d = 25 – 30 mm

Main dimensions			Basic load ratings		Fatigue limit load C_{ur} N	Limiting speed n_G min^{-1}	Speed rating n_{dr} min^{-1}	Mass m		Designation	
d	D	B	dyn. C_r N	stat. C_{0r} N				Bearing \approx kg	L-section ring \approx kg	Bearing	L-section ring
25	52	15	34 500	27 500	4 350	17 200	11 600	0,14	–	NJ205-E-XL-TVP2	–
	52	15	34 500	27 500	4 350	17 200	11 600	0,14	0,014	NJ205-E-XL-TVP2	HJ205-E
	52	15	34 500	27 500	4 400	17 200	11 600	0,145	–	NUP205-E-XL-TVP2	–
	52	18	41 500	34 500	5 700	17 200	9 600	0,17	–	NJ2205-E-XL-TVP2	–
	52	18	41 500	34 500	5 700	17 200	9 600	0,17	0,015	NJ2205-E-XL-TVP2	HJ2205-E
	52	18	41 500	34 500	5 700	17 200	9 600	0,174	–	NUP2205-E-XL-TVP2	–
	62	17	49 000	37 500	5 600	14 400	10 100	0,25	–	NJ305-E-XL-TVP2	–
	62	17	49 000	37 500	5 600	14 400	10 100	0,25	0,025	NJ305-E-XL-TVP2	HJ305-E
	62	17	49 000	37 500	5 600	14 400	10 100	0,256	–	NUP305-E-XL-TVP2	–
	62	24	66 000	54 000	9 200	14 400	8 300	0,356	–	NJ2305-E-XL-TVP2	–
	62	24	66 000	54 000	9 200	14 400	8 300	0,356	0,027	NJ2305-E-XL-TVP2	HJ2305-E
62	24	67 000	56 000	9 200	14 400	8 200	0,364	–	NUP2305-E-XL-TVP2	–	
30	62	16	46 000	37 500	5 400	14 200	9 600	0,213	–	NJ206-E-XL-TVP2	–
	62	16	46 000	37 500	5 400	14 200	9 600	0,213	0,024	NJ206-E-XL-TVP2	HJ206-E
	62	16	46 000	37 500	5 400	14 200	9 600	0,219	–	NUP206-E-XL-TVP2	–
	62	20	58 000	50 000	7 800	14 200	8 000	0,261	–	NJ2206-E-XL-TVP2	–
	62	20	58 000	50 000	7 800	14 200	8 000	0,261	0,025	NJ2206-E-XL-TVP2	HJ2206-E
	62	20	58 000	50 000	7 800	14 200	8 000	0,268	–	NUP2206-E-XL-TVP2	–
	72	19	61 000	48 000	7 700	12 400	8 900	0,376	–	NJ306-E-XL-TVP2	–
	72	19	61 000	48 000	7 700	12 400	8 900	0,376	0,042	NJ306-E-XL-TVP2	HJ306-E
	72	19	61 000	48 000	7 700	12 400	8 900	0,385	–	NUP306-E-XL-TVP2	–
	72	27	86 000	75 000	13 100	12 400	7 200	0,54	–	NJ2306-E-XL-TVP2	–
	72	27	86 000	75 000	13 100	12 400	7 200	0,54	0,044	NJ2306-E-XL-TVP2	HJ2306-E
	72	27	86 000	75 000	13 100	12 400	7 200	0,551	–	NUP2306-E-XL-TVP2	–
	90	23	84 000	65 000	11 000	13 400	8 100	0,872	–	NJ406-XL-M1	–
	90	23	84 000	65 000	11 000	13 400	8 100	0,872	0,082	NJ406-XL-M1	HJ406

medias ► <https://www.schaeffler.de/std/1DA9>

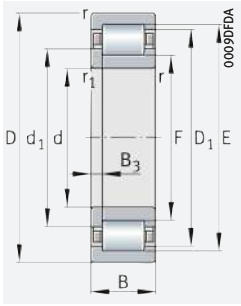

NUP
Locating bearing

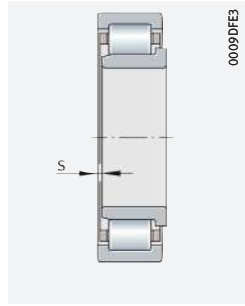

Axial displacement "s"
for NJ

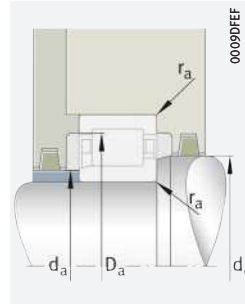

Mounting dimensions
for NJ

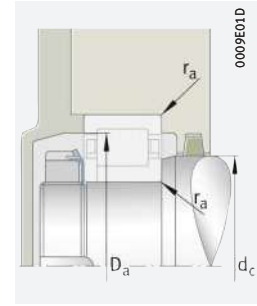

Mounting dimensions
for NUP

Dimensions

Mounting dimensions

d	r	r ₁	s	E	F	D ₁	d ₁	B ₁	B ₂	B ₃	d _a		d _c	D _a	r _a
											min. ¹⁾	max.			
25	1	0,6	1,2	46,5	31,5	43,8	34,7	-	-	-	29	31	37	46	1
	1	0,6	-	46,5	31,5	43,8	34,7	3	6	-	29	-	37	46	1
	1	0,6	-	46,5	31,5	43,8	34,7	-	-	3	29	-	37	46	1
	1	0,6	1,7	46,5	31,5	43,8	34,7	-	-	-	29	31	37	46	1
	1	0,6	-	46,5	31,5	43,8	34,7	3	6,5	-	29	-	37	46	1
	1	0,6	-	46,5	31,5	43,8	34,7	-	-	3,5	29	-	37	46	1
	1,1	1,1	1,5	54	34	50,7	38,1	-	-	-	32	33	40	55	1
	1,1	1,1	-	54	34	50,7	38,1	4	7	-	32	-	40	55	1
	1,1	1,1	-	54	34	50,7	38,1	-	-	3	32	-	40	55	1
	1,1	1,1	1,9	54	34	50,7	38,1	-	-	-	32	33	40	55	1
	1,1	1,1	-	54	34	50,7	38,1	4	8	-	32	-	40	55	1
30	1	0,6	1,5	55,5	37,5	52,5	41,1	-	-	-	34	37	44	56	1
	1	0,6	-	55,5	37,5	52,5	41,1	4	7	-	34	-	44	56	1
	1	0,6	-	55,5	37,5	52,5	41,1	-	-	3	34	-	44	56	1
	1	0,6	1,6	55,5	37,5	52,5	41,3	-	-	-	34	37	44	56	1
	1	0,6	-	55,5	37,5	52,5	41,3	4	7,5	-	34	-	44	56	1
	1	0,6	-	55,5	37,5	52,5	41,3	-	-	3,5	34	-	44	56	1
	1,1	1,1	1,2	62,5	40,5	59,2	45	-	-	-	37	40	48	65	1
	1,1	1,1	-	62,5	40,5	59,2	45	5	8,5	-	37	-	48	65	1
	1,1	1,1	-	62,5	40,5	59,2	45	-	-	3,5	37	-	48	65	1
	1,1	1,1	2,2	62,5	40,5	59,2	45	-	-	-	37	40	48	65	1
	1,1	1,1	-	62,5	40,5	59,2	45	5	9,5	-	37	-	48	65	1
	1,1	1,1	-	62,5	40,5	59,2	45	-	-	4,5	37	-	48	65	1
	1,5	1,5	2,3	73	45	68,4	50,3	-	-	-	41	44	52	79	1,5
	1,5	1,5	-	73	45	68,4	50,3	7	11,5	-	41	-	52	79	1,5

¹⁾ Under axial load, observe the dimensions D₁ and d₁.





Cylindrical roller bearings with cage

Semi-locating bearings, locating bearings

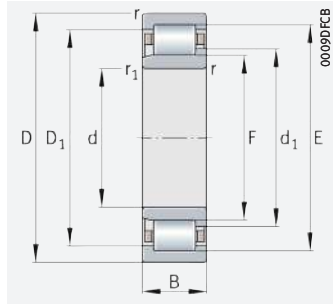

NJ
Semi-locating bearing

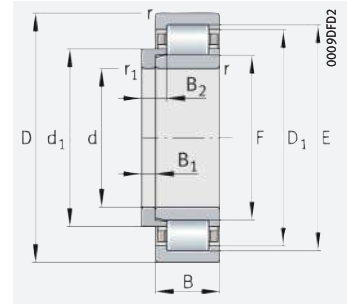

NJ and HJ
Locating bearings

d = 35 – 40 mm

Main dimensions			Basic load ratings		Fatigue limit load C_{ur} N	Limiting speed n_G min^{-1}	Speed rating $n_{\varnothing r}$ min^{-1}	Mass m		Designation ▶425 1.12 ▶426 1.13 X-life ▶415	Bearing	L-section ring
d	D	B	dyn. C_r N	stat. C_{0r} N				Bearing \approx kg	L-section ring \approx kg			
35	72	17	59 000	50 000	7 600	12 300	8 100	0,309	–	NJ207-E-XL-TVP2	–	
	72	17	59 000	50 000	7 600	12 300	8 100	0,309	0,032	NJ207-E-XL-TVP2	HJ207-E	
	72	17	59 000	50 000	7 600	12 300	8 100	0,317	–	NUP207-E-XL-TVP2	–	
	72	23	73 000	65 000	10 500	12 300	7 200	0,416	–	NJ2207-E-XL-TVP2	–	
	72	23	73 000	65 000	10 500	12 300	7 200	0,416	0,035	NJ2207-E-XL-TVP2	HJ2207-E	
	72	23	73 000	65 000	10 500	12 300	7 200	0,427	–	NUP2207-E-XL-TVP2	–	
	80	21	76 000	63 000	10 600	10 900	7 900	0,496	–	NJ307-E-XL-TVP2	–	
	80	21	76 000	63 000	10 600	10 900	7 900	0,496	0,06	NJ307-E-XL-TVP2	HJ307-E	
	80	21	76 000	63 000	10 600	10 900	7 900	0,506	–	NUP307-E-XL-TVP2	–	
	80	31	108 000	98 000	17 500	10 900	6 600	0,736	–	NJ2307-E-XL-TVP2	–	
	80	31	108 000	98 000	17 500	10 900	6 600	0,736	0,063	NJ2307-E-XL-TVP2	HJ2307-E	
40	80	18	63 000	53 000	8 300	10 900	7 500	0,389	–	NJ208-E-XL-TVP2	–	
	80	18	63 000	53 000	8 300	10 900	7 500	0,389	0,049	NJ208-E-XL-TVP2	HJ208-E	
	80	18	63 000	53 000	8 400	10 900	7 500	0,399	–	NUP208-E-XL-TVP2	–	
	80	23	83 000	75 000	12 700	10 900	6 300	0,504	–	NJ2208-E-XL-TVP2	–	
	80	23	83 000	75 000	12 700	10 900	6 300	0,504	0,05	NJ2208-E-XL-TVP2	HJ2208-E	
	80	23	83 000	75 000	12 700	10 900	6 300	0,518	–	NUP2208-E-XL-TVP2	–	
	90	23	96 000	79 000	13 500	9 500	7 100	0,674	–	NJ308-E-XL-TVP2	–	
	90	23	96 000	79 000	13 500	9 500	7 100	0,674	0,087	NJ308-E-XL-TVP2	HJ308-E	
	90	23	96 000	79 000	13 600	9 500	7 100	0,688	–	NUP308-E-XL-TVP2	–	
	90	33	132 000	119 000	21 600	9 500	5 800	0,978	–	NJ2308-E-XL-TVP2	–	
	90	33	132 000	119 000	21 600	9 500	5 800	0,978	0,091	NJ2308-E-XL-TVP2	HJ2308-E	
40	90	33	132 000	119 000	21 600	9 500	5 800	0,999	–	NUP2308-E-XL-TVP2	–	
	110	27	119 000	95 000	16 800	10 500	6 500	1,5	–	NJ408-XL-M1	–	
	110	27	119 000	95 000	16 800	10 500	6 500	1,5	0,148	NJ408-XL-M1	HJ408	

medias ▶ <https://www.schaeffler.de/std/1DA4>

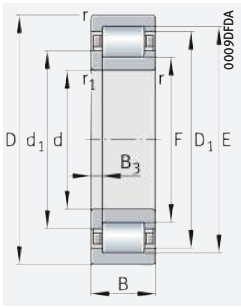

NUP
Locating bearing

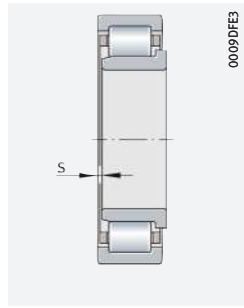

Axial displacement "s"
for NJ

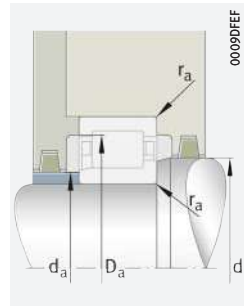

Mounting dimensions
for NJ

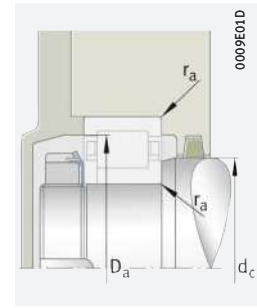

Mounting dimensions
for NUP

Dimensions

Mounting dimensions

d	r	r ₁	s	E	F	D ₁	d ₁	B ₁	B ₂	B ₃	d _a		d _c	D _a	r _a
											min. ¹⁾	max.			
35	1,1	0,6	0,7	64	44	61	48	-	-	-	39	43	50	65	1
	1,1	0,6	-	64	44	61	48	4	7	-	39	-	50	65	1
	1,1	0,6	-	64	44	61	48	-	-	3	39	-	50	65	1
	1,1	0,6	2,2	64	44	61	48	-	-	-	39	43	50	65	1
	1,1	0,6	-	64	44	61	48	4	8,5	-	39	-	50	65	1
	1,1	0,6	-	64	44	61	48	-	-	4,5	39	-	50	65	1
	1,5	1,1	0,6	70,2	46,2	66,6	51	-	-	-	42	45	53	71	1,5
	1,5	1,1	-	70,2	46,2	66,6	51	6	9,5	-	42	-	53	71	1,5
	1,5	1,1	-	70,2	46,2	66,6	51	-	-	3,5	42	-	53	71	1,5
	1,5	1,1	2,1	70,2	46,2	66,6	51	-	-	-	42	45	53	71	1,5
	1,5	1,1	-	70,2	46,2	66,6	51	6	11	-	42	-	53	71	1,5
	1,5	1,5	-	70,2	46,2	66,6	51	-	-	5	42	-	53	71	1,5
40	1,1	1,1	1	71,5	49,5	68,3	54	-	-	-	47	49	56	73	1
	1,1	1,1	-	71,5	49,5	68,3	54	5	8,5	-	47	-	56	73	1
	1,1	1,1	-	71,5	49,5	68,3	54	-	-	3,5	47	-	56	73	1
	1,1	1,1	1,5	71,5	49,5	68,3	54	-	-	-	47	49	56	73	1
	1,1	1,1	-	71,5	49,5	68,3	54	5	9	-	47	-	56	73	1
	1,1	1,1	-	71,5	49,5	68,3	54	-	-	4	47	-	56	73	1
	1,5	1,5	1,3	80	52	75,9	57,6	-	-	-	49	51	60	81	1,5
	1,5	1,5	-	80	52	75,9	57,6	7	11	-	49	-	60	81	1,5
	1,5	1,5	-	80	52	75,9	57,6	-	-	4	49	-	60	81	1,5
	1,5	1,5	2,7	80	52	75,9	57,6	-	-	-	49	51	60	81	1,5
	1,5	1,5	-	80	52	75,9	57,6	7	12,5	-	49	-	60	81	1,5
	1,5	1,5	-	80	52	75,9	57,6	-	-	5,5	49	-	60	81	1,5
	2	2	2,8	92	58	86,4	64,6	-	-	-	53	57	67	97	2
	2	2	-	92	58	86,4	64,6	8	13	-	53	-	67	97	2

¹⁾ Under axial load, observe the dimensions D₁ and d₁.





Cylindrical roller bearings with cage

Semi-locating bearings, locating bearings

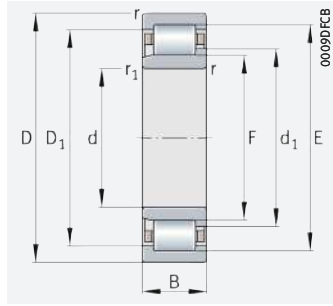

NJ
Semi-locating bearing

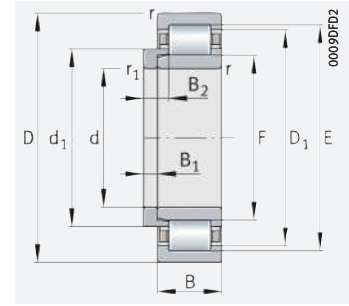

NJ and HJ
Locating bearings

d = 45 – 50 mm

Main dimensions			Basic load ratings		Fatigue limit load C_{ur} N	Limiting speed n_G min^{-1}	Speed rating $n_{\varnothing r}$ min^{-1}	Mass m		Designation ▶425 1.12 ▶426 1.13 X-life ▶415	Bearing	L-section ring
d	D	B	dyn. C_r N	stat. C_{0r} N				Bearing \approx kg	L-section ring \approx kg			
45	85	19	72 000	63 000	10 300	10 200	7 000	0,445	–	NJ209-E-XL-TVP2	–	
	85	19	72 000	63 000	10 300	10 200	7 000	0,445	0,054	NJ209-E-XL-TVP2	HJ209-E	
	85	19	72 000	63 000	10 300	10 200	7 000	0,457	–	NUP209-E-XL-TVP2	–	
	85	23	87 000	82 000	13 900	10 200	5 800	0,544	–	NJ2209-E-XL-TVP2	–	
	85	23	87 000	82 000	13 900	10 200	5 800	0,544	0,055	NJ2209-E-XL-TVP2	HJ2209-E	
	85	23	87 000	82 000	13 900	10 200	5 800	0,559	–	NUP2209-E-XL-TVP2	–	
	100	25	116 000	99 000	17 200	8 500	6 400	0,913	–	NJ309-E-XL-TVP2	–	
	100	25	116 000	99 000	17 200	8 500	6 400	0,913	0,109	NJ309-E-XL-TVP2	HJ309-E	
	100	25	116 000	99 000	17 300	8 500	6 400	0,937	–	NUP309-E-XL-TVP2	–	
	100	36	163 000	154 000	28 000	8 500	5 200	1,33	–	NJ2309-E-XL-TVP2	–	
	100	36	163 000	154 000	28 000	8 500	5 200	1,33	0,115	NJ2309-E-XL-TVP2	HJ2309-E	
	100	36	163 000	154 000	28 000	8 500	5 200	1,36	–	NUP2309-E-XL-TVP2	–	
50	120	29	143 000	119 000	21 400	9 600	5 900	1,9	–	NJ409-XL-M1	–	
	120	29	143 000	119 000	21 400	9 600	5 900	1,9	0,181	NJ409-XL-M1	HJ409	
	90	20	75 000	69 000	11 100	9 700	6 600	0,503	–	NJ210-E-XL-TVP2	–	
		20	75 000	69 000	11 100	9 700	6 600	0,503	0,06	NJ210-E-XL-TVP2	HJ210-E	
		20	75 000	69 000	11 200	9 700	6 600	0,517	–	NUP210-E-XL-TVP2	–	
	90	23	92 000	88 000	15 000	9 700	5 300	0,586	–	NJ2210-E-XL-TVP2	–	
		23	92 000	88 000	15 000	9 700	5 300	0,586	0,06	NJ2210-E-XL-TVP2	HJ210-E	
		23	92 000	88 000	15 000	9 700	5 300	0,597	–	NUP2210-E-XL-TVP2	–	
	110	27	131 000	114 000	20 100	7 800	6 000	1,19	–	NJ310-E-XL-TVP2	–	
		27	131 000	114 000	20 100	7 800	6 000	1,19	0,149	NJ310-E-XL-TVP2	HJ310-E	
		27	131 000	114 000	20 100	7 800	6 000	1,21	–	NUP310-E-XL-TVP2	–	
	110	40	193 000	187 000	34 500	7 800	4 900	1,77	–	NJ2310-E-XL-TVP2	–	
40		193 000	187 000	34 500	7 800	4 900	1,77	0,156	NJ2310-E-XL-TVP2	HJ2310-E		
40		193 000	187 000	34 500	7 800	4 900	1,82	–	NUP2310-E-XL-TVP2	–		
130	31	175 000	148 000	27 000	8 600	5 300	2,36	–	NJ410-XL-M1	–		
	31	175 000	148 000	27 000	8 600	5 300	2,36	0,238	NJ410-XL-M1	HJ410		

medias ▶ <https://www.schaeffler.de/std/1DAB>

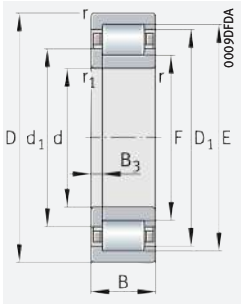

NUP
Locating bearing

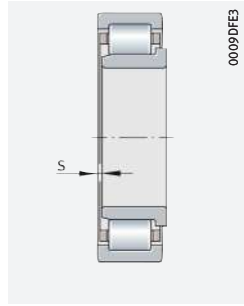

Axial displacement "s"
for NJ

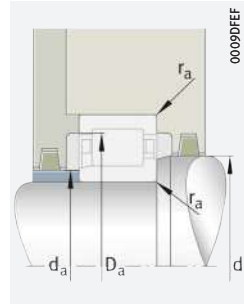

Mounting dimensions
for NJ

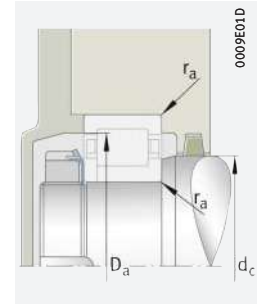

Mounting dimensions
for NUP

Dimensions

Mounting dimensions

d	r	r ₁	s	E	F	D ₁	d ₁	B ₁	B ₂	B ₃	d _a		d _c	D _a	r _a	
											min. ¹⁾	max.				min.
45	1,1	1,1	1,9	76,5	54,5	73,3	59	-	-	-	52	54	61	78	1	
	1,1	1,1	-	76,5	54,5	73,3	59	5	8,5	-	52	-	61	78	1	
	1,1	1,1	-	76,5	54,5	73,3	59	-	-	3,5	52	-	61	78	1	
	1,1	1,1	1,5	76,5	54,5	73,3	59	-	-	-	52	54	61	78	1	
	1,1	1,1	-	76,5	54,5	73,3	59	5	9	-	52	-	61	78	1	
	1,1	1,1	-	76,5	54,5	73,3	59	-	-	4	52	-	61	78	1	
	1,5	1,5	1	88,5	58,5	84,1	64,4	-	-	-	54	57	66	91	1,5	
	1,5	1,5	-	88,5	58,5	84,1	64,4	7	11,5	-	54	-	66	91	1,5	
	1,5	1,5	-	88,5	58,5	84,1	64,4	-	-	4,5	54	-	66	91	1,5	
	1,5	1,5	2,5	88,5	58,5	84,1	64,4	-	-	-	54	57	66	91	1,5	
	1,5	1,5	-	88,5	58,5	84,1	64,4	7	13	-	54	-	66	91	1,5	
	1,5	1,5	-	88,5	58,5	84,1	64,4	-	-	6	54	-	66	91	1,5	
50	2	2	2,9	100,5	64,5	94,6	71,6	-	-	-	58	63	74	107	2	
	2	2	-	100,5	64,5	94,6	71,6	8	13,5	-	58	-	74	107	2	
	50	1,1	1,1	1,3	81,5	59,5	78,3	64	-	-	-	57	58	67	83	1
		1,1	1,1	-	81,5	59,5	78,3	64	5	9	-	57	-	67	83	1
		1,1	1,1	-	81,5	59,5	78,3	64	-	-	4	57	-	67	83	1
		1,1	1,1	1,3	81,5	59,5	78,3	64	-	-	-	57	58	67	83	1
		1,1	1,1	-	81,5	59,5	78,3	64	5	9	-	57	-	67	83	1
		1,1	1,1	-	81,5	59,5	78,3	64	-	-	4	57	-	67	83	1
		2	2	1,7	97	65	92,5	71,3	-	-	-	61	63	73	99	2
		2	2	-	97	65	92,5	71,3	8	13	-	61	-	73	99	2
		2	2	-	97	65	92,5	71,3	-	-	5	61	-	73	99	2
		2	2	4,2	97	65	92,5	71,3	-	-	-	61	63	73	99	2
2		2	-	97	65	92,5	71,3	8	14,5	-	61	-	73	99	2	
2		2	-	97	65	92,5	71,3	-	-	6,5	61	-	73	99	2	
2,1	2,1	3	110,8	70,8	104,3	78,6	-	-	-	64	69	81	116	2		
2,1	2,1	-	110,8	70,8	104,3	78,6	9	14,5	-	64	-	81	116	2		

¹⁾ Under axial load, observe the dimensions D₁ and d₁.





Cylindrical roller bearings with cage

Semi-locating bearings, locating bearings

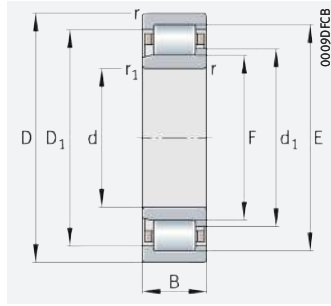

NJ
Semi-locating bearing

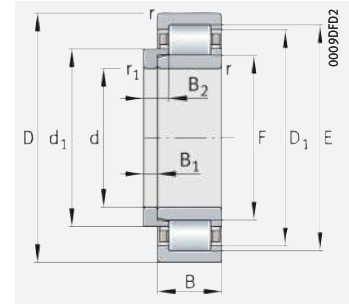

NJ and HJ
Locating bearings

d = 55 – 60 mm

Main dimensions			Basic load ratings		Fatigue limit load C_{ur} N	Limiting speed n_G min^{-1}	Speed rating $n_{\varnothing r}$ min^{-1}	Mass m		Designation ▶425 1.12 ▶426 1.13 X-life ▶415	Bearing	L-section ring
d	D	B	dyn. C_r N	stat. C_{0r} N				Bearing \approx kg	L-section ring \approx kg			
55	100	21	99 000	95 000	16 100	8 700	5 800	0,679	–	NJ211-E-XL-TVP2	–	
	100	21	99 000	95 000	16 100	8 700	5 800	0,679	0,087	NJ211-E-XL-TVP2	HJ211-E	
	100	21	99 000	95 000	16 100	8 700	5 800	0,693	–	NUP211-E-XL-TVP2	–	
	100	25	117 000	118 000	20 600	8 700	4 700	0,812	–	NJ2211-E-XL-TVP2	–	
	100	25	117 000	118 000	20 600	8 700	4 700	0,812	0,087	NJ2211-E-XL-TVP2	HJ2211-E	
	100	25	117 000	118 000	20 600	8 700	4 700	0,828	–	NUP2211-E-XL-TVP2	–	
	120	29	159 000	139 000	25 000	7 000	5 500	1,51	–	NJ311-E-XL-TVP2	–	
	120	29	159 000	139 000	25 000	7 000	5 500	1,51	0,192	NJ311-E-XL-TVP2	HJ311-E	
	120	29	159 000	139 000	25 500	7 000	5 500	1,54	–	NUP311-E-XL-TVP2	–	
	120	43	235 000	230 000	43 500	7 000	4 500	2,27	–	NJ2311-E-XL-TVP2	–	
	120	43	235 000	230 000	43 500	7 000	4 500	2,27	0,2	NJ2311-E-XL-TVP2	HJ2311-E	
	120	43	235 000	230 000	43 000	7 000	4 500	2,31	–	NUP2311-E-XL-TVP2	–	
60	140	33	187 000	164 000	30 000	8 200	5 100	2,88	–	NJ411-XL-M1	–	
	140	33	187 000	164 000	30 000	8 200	5 100	2,88	0,302	NJ411-XL-M1	HJ411	
	110	22	112 000	103 000	17 700	7 700	5 300	0,845	–	NJ212-E-XL-TVP2	–	
	110	22	112 000	103 000	17 700	7 700	5 300	0,845	0,106	NJ212-E-XL-TVP2	HJ212-E	
	110	22	112 000	103 000	17 800	7 700	5 300	0,865	–	NUP212-E-XL-TVP2	–	
	110	28	152 000	153 000	27 500	7 700	4 300	1,1	–	NJ2212-E-XL-TVP2	–	
	110	28	152 000	153 000	27 500	7 700	4 300	1,1	0,106	NJ2212-E-XL-TVP2	HJ212-E	
	110	28	152 000	153 000	27 500	7 700	4 300	1,12	–	NUP2212-E-XL-TVP2	–	
	130	31	177 000	157 000	28 500	6 500	5 200	1,89	–	NJ312-E-XL-TVP2	–	
	130	31	177 000	157 000	28 500	6 500	5 200	1,89	0,229	NJ312-E-XL-TVP2	HJ312-E	
	130	31	177 000	157 000	28 500	6 500	5 200	1,93	–	NUP312-E-XL-TVP2	–	
	130	46	265 000	260 000	49 500	6 500	4 250	2,83	–	NJ2312-E-XL-TVP2	–	
	130	46	265 000	260 000	49 500	6 500	4 250	2,83	0,238	NJ2312-E-XL-TVP2	HJ2312-E	
	130	46	265 000	260 000	49 500	6 500	4 250	2,88	–	NUP2312-E-XL-TVP2	–	
	150	35	211 000	184 000	33 000	7 500	4 800	3,47	–	NJ412-XL-M1	–	
150	35	211 000	184 000	33 000	7 500	4 800	3,47	0,347	NJ412-XL-M1	HJ412		

medias ▶ <https://www.schaeffler.de/std/1DAC>

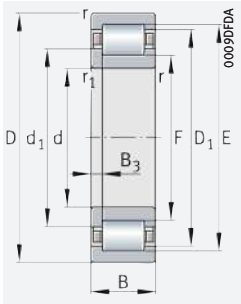

NUP
Locating bearing

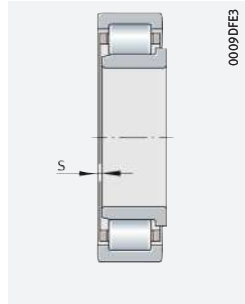

Axial displacement "s"
for NJ

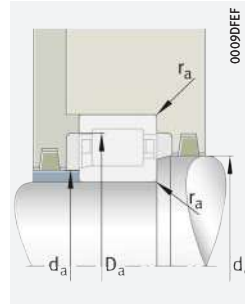

Mounting dimensions
for NJ

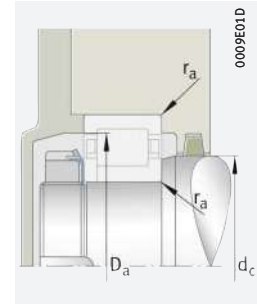

Mounting dimensions
for NUP

Dimensions

Mounting dimensions

d	r	r ₁	s	E	F	D ₁	d ₁	B ₁	B ₂	B ₃	Mounting dimensions				
											d _a		d _c	D _a	r _a
											min. ¹⁾	max.			
55	1,5	1,1	0,8	90	66	86,6	70,8	-	-	-	62	65	73	91	1,5
	1,5	1,1	-	90	66	86,6	70,8	6	9,5	-	62	-	73	91	1,5
	1,5	1,1	-	90	66	86,6	70,8	-	-	3,5	62	-	73	91	1,5
	1,5	1,1	1,3	90	66	86,6	70,8	-	-	-	62	65	73	91	1,5
	1,5	1,1	-	90	66	86,6	70,8	6	10	-	62	-	73	91	1,5
	1,5	1,1	-	90	66	86,6	70,8	-	-	4	62	-	73	91	1,5
	2	2	1,8	106,5	70,5	101,4	77,5	-	-	-	66	69	80	109	2
	2	2	-	106,5	70,5	101,4	77,5	9	14	-	66	-	80	109	2
	2	2	-	106,5	70,5	101,4	77,5	-	-	5	66	-	80	109	2
	2	2	3,3	106,5	70,5	101,4	77,5	-	-	-	66	69	80	109	2
	2	2	-	106,5	70,5	101,4	77,5	9	15,5	-	66	-	80	109	2
	2	2	-	106,5	70,5	101,4	77,5	-	-	6,5	66	-	80	109	2
60	2,1	2,1	3,3	117,2	77,2	110,7	85	-	-	-	69	76	87	126	2,1
	2,1	2,1	-	117,2	77,2	110,7	85	10	16,5	-	69	-	87	126	2,1
	1,5	1,5	1,6	100	72	96,1	77,6	-	-	-	69	71	80	101	1,5
	1,5	1,5	-	100	72	96,1	77,6	6	10	-	69	-	80	101	1,5
	1,5	1,5	-	100	72	96,1	77,6	-	-	4	69	-	80	101	1,5
	1,5	1,5	1,6	100	72	96,1	77,6	-	-	-	69	71	80	101	1,5
	1,5	1,5	-	100	72	96,1	77,6	6	10	-	69	-	80	101	1,5
	1,5	1,5	-	100	72	96,1	77,6	-	-	4	69	-	80	101	1,5
	2,1	2,1	1,8	115	77	109,6	84,4	-	-	-	72	75	86	118	2,1
	2,1	2,1	-	115	77	109,6	84,4	9	14,5	-	72	-	86	118	2,1
	2,1	2,1	-	115	77	109,6	84,4	-	-	5,5	72	-	86	118	2,1
	2,1	2,1	3,5	115	77	109,6	84,4	-	-	-	72	75	86	118	2,1
2,1	2,1	-	115	77	109,6	84,4	9	16	-	72	-	86	118	2,1	
2,1	2,1	-	115	77	109,6	84,4	-	-	7	72	-	86	118	2,1	
2,1	2,1	3,4	127	83	119,5	91,6	-	-	-	74	82	94	136	2	
2,1	2,1	-	127	83	119,5	91,6	10	16,5	-	74	-	94	136	2	

¹⁾ Under axial load, observe the dimensions D₁ and d₁.



Cylindrical roller bearings with cage

Semi-locating bearings, locating bearings

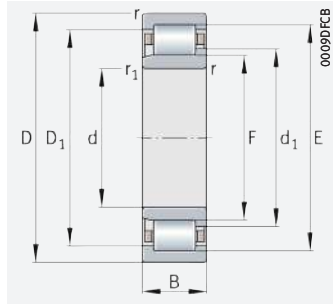

NJ
Semi-locating bearing

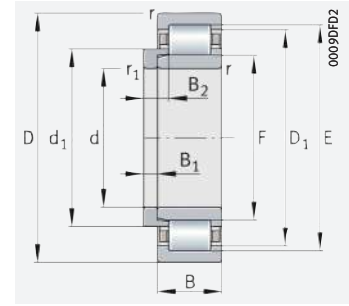

NJ and HJ
Locating bearings

d = 65 – 70 mm

Main dimensions			Basic load ratings		Fatigue limit load C_{ur} N	Limiting speed n_G min^{-1}	Speed rating $n_{\varnothing r}$ min^{-1}	Mass m		Designation ▶425 1.12 ▶426 1.13 X-life ▶415	Bearing	L-section ring
d	D	B	dyn. C_r N	stat. C_{0r} N				Bearing \approx kg	L-section ring \approx kg			
65	120	23	128 000	120 000	20 700	7 100	4 900	1,06	–	NJ213-E-XL-TVP2	–	
	120	23	128 000	120 000	20 700	7 100	4 900	1,06	0,127	NJ213-E-XL-TVP2	HJ213-E	
	120	23	128 000	120 000	20 800	7 100	4 900	1,09	–	NUP213-E-XL-TVP2	–	
	120	31	177 000	182 000	33 000	7 100	4 100	1,46	–	NJ2213-E-XL-TVP2	–	
	120	31	177 000	182 000	33 000	7 100	4 100	1,46	0,13	NJ2213-E-XL-TVP2	HJ2213-E	
	120	31	177 000	182 000	33 000	7 100	4 100	1,54	–	NUP2213-E-XL-TVP2	–	
	140	33	214 000	191 000	34 500	5 900	4 800	2,32	–	NJ313-E-XL-TVP2	–	
	140	33	214 000	191 000	34 500	5 900	4 800	2,32	0,285	NJ313-E-XL-TVP2	HJ313-E	
	140	33	214 000	191 000	34 500	5 900	4 800	2,37	–	NUP313-E-XL-TVP2	–	
	140	48	295 000	285 000	53 000	5 900	4 000	3,38	–	NJ2313-E-XL-TVP2	–	
	140	48	295 000	285 000	53 000	5 900	4 000	3,38	0,303	NJ2313-E-XL-TVP2	HJ2313-E	
	140	48	295 000	285 000	53 000	5 900	4 000	3,45	–	NUP2313-E-XL-TVP2	–	
70	160	37	230 000	203 000	36 000	7 000	4 600	4,15	–	NJ413-XL-M1	–	
	160	37	230 000	203 000	36 000	7 000	4 600	4,15	0,432	NJ413-XL-M1	HJ413	
	125	24	141 000	138 000	24 100	6 800	4 650	1,18	–	NJ214-E-XL-TVP2	–	
	125	24	141 000	138 000	24 100	6 800	4 650	1,18	0,155	NJ214-E-XL-TVP2	HJ214-E	
	125	24	141 000	138 000	24 300	6 800	4 650	1,2	–	NUP214-E-XL-TVP2	–	
	125	31	185 000	195 000	35 500	6 800	3 850	1,54	–	NJ2214-E-XL-TVP2	–	
	125	31	185 000	195 000	35 500	6 800	3 850	1,54	0,157	NJ2214-E-XL-TVP2	HJ2214-E	
	125	31	185 000	195 000	35 500	6 800	3 850	1,58	–	NUP2214-E-XL-TVP2	–	
	150	35	242 000	222 000	39 500	5 500	4 500	2,84	–	NJ314-E-XL-TVP2	–	
	150	35	242 000	222 000	39 500	5 500	4 500	2,84	0,328	NJ314-E-XL-TVP2	HJ314-E	
	150	35	242 000	222 000	39 500	5 500	4 500	2,89	–	NUP314-E-XL-TVP2	–	
	150	51	325 000	325 000	59 000	5 500	3 800	4,1	–	NJ2314-E-XL-TVP2	–	
	150	51	325 000	325 000	59 000	5 500	3 800	4,1	0,352	NJ2314-E-XL-TVP2	HJ2314-E	
	150	51	325 000	325 000	59 000	5 500	3 800	4,18	–	NUP2314-E-XL-TVP2	–	
	180	42	285 000	255 000	45 000	6 200	4 250	6,07	–	NJ414-XL-M1	–	
	180	42	285 000	255 000	45 000	6 200	4 250	6,07	0,63	NJ414-XL-M1	HJ414	

medias ▶ <https://www.schaeffler.de/std/1DAD>

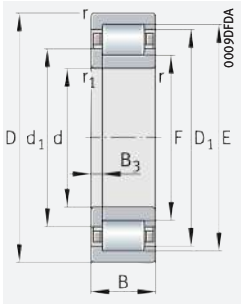

NUP
Locating bearing

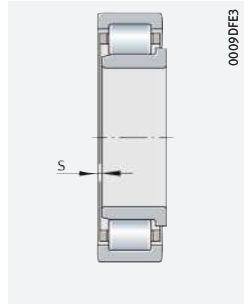

Axial displacement "s"
for NJ

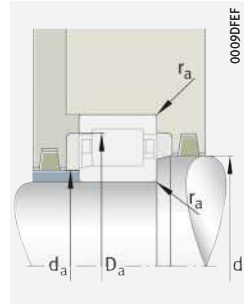

Mounting dimensions
for NJ

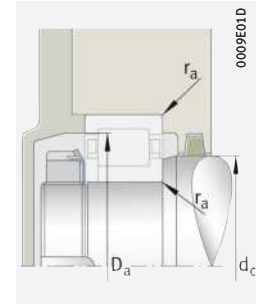

Mounting dimensions
for NUP

Dimensions

Mounting dimensions

d	r	r ₁	s	E	F	D ₁	d ₁	B ₁	B ₂	B ₃	d _a		d _c	D _a	r _a
											min. ¹⁾	max.			
65	1,5	1,5	1,4	108,5	78,5	104,3	84,4	-	-	-	74	77	87	111	1,5
	1,5	1,5	-	108,5	78,5	104,3	84,4	6	10	-	74	-	87	111	1,5
	1,5	1,5	-	108,5	78,5	104,3	84,4	-	-	4	74	-	87	111	1,5
	1,5	1,5	1,9	108,5	78,5	104,3	84,4	-	-	-	74	77	87	111	1,5
	1,5	1,5	-	108,5	78,5	104,3	84,4	6	10,5	-	74	-	87	111	1,5
	1,5	1,5	-	108,5	78,5	104,3	84,4	-	-	4,5	74	-	87	111	1,5
	2,1	2,1	1,5	124,5	82,5	118,6	90,5	-	-	-	77	81	93	128	2,1
	2,1	2,1	-	124,5	82,5	118,6	90,5	10	15,5	-	77	-	93	128	2,1
	2,1	2,1	-	124,5	82,5	118,6	90,5	-	-	5,5	77	-	93	128	2,1
	2,1	2,1	4	124,5	82,5	118,6	90,5	-	-	-	77	81	93	128	2,1
	2,1	2,1	-	124,5	82,5	118,6	90,5	10	18	-	77	-	93	128	2,1
	2,1	2,1	-	124,5	82,5	118,6	90,5	-	-	8	77	-	93	128	2,1
70	1,5	1,5	1,2	113,5	83,5	109,4	89,4	-	-	-	79	82	92	116	1,5
	1,5	1,5	-	113,5	83,5	109,4	89,4	7	11	-	79	-	92	116	1,5
	1,5	1,5	-	113,5	83,5	109,4	89,4	-	-	4	79	-	92	116	1,5
	1,5	1,5	1,6	113,5	83,5	109,4	89,4	-	-	-	79	-	92	116	1,5
	1,5	1,5	-	113,5	83,5	109,4	89,4	7	11,5	-	79	-	92	116	1,5
	1,5	1,5	-	113,5	83,5	109,4	89,4	-	-	4,5	79	-	92	116	1,5
	2,1	2,1	1,7	133	89	126,8	97,4	-	-	-	82	87	100	138	2,1
	2,1	2,1	-	133	89	126,8	97,4	10	15,5	-	82	-	100	138	2,1
	2,1	2,1	-	133	89	126,8	97,4	-	-	5,5	82	-	100	138	2,1
	2,1	2,1	4,7	133	89	126,8	97,4	-	-	-	82	87	100	138	2,1
	2,1	2,1	-	133	89	126,8	97,4	10	18,5	-	82	-	100	138	2,1
	2,1	2,1	-	133	89	126,8	97,4	-	-	8,5	82	-	100	138	2,1
3	3	4	152	100	142,7	110,3	-	-	-	86	99	112	164	2,5	
3	3	-	152	100	142,7	110,3	12	20	-	86	-	112	164	2,5	

¹⁾ Under axial load, observe the dimensions D₁ and d₁.





Cylindrical roller bearings with cage

Semi-locating bearings, locating bearings

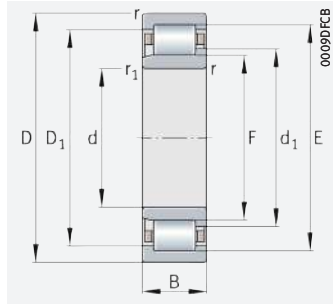

NJ
Semi-locating bearing

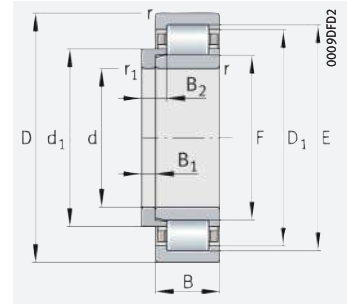

NJ and HJ
Locating bearings

d = 75 – 80 mm

Main dimensions			Basic load ratings		Fatigue limit load C_{ur} N	Limiting speed n_G min^{-1}	Speed rating $n_{\varnothing r}$ min^{-1}	Mass m		Designation ▶425 1.12 ▶426 1.13 X-life ▶415	Bearing	L-section ring
d	D	B	dyn. C_r N	stat. C_{Or} N				Bearing \approx kg	L-section ring \approx kg			
75	130	25	155 000	157 000	27 500	6 500	4 400	1,3	–	NJ215-E-XL-TVP2	–	
	130	25	155 000	157 000	27 500	6 500	4 400	1,3	0,164	NJ215-E-XL-TVP2	HJ215-E	
	130	25	155 000	157 000	27 500	6 500	4 400	1,33	–	NUP215-E-XL-TVP2	–	
	130	31	192 000	208 000	37 500	6 500	3 600	1,64	–	NJ2215-E-XL-TVP2	–	
	130	31	192 000	208 000	37 500	6 500	3 600	1,64	0,165	NJ2215-E-XL-TVP2	HJ2215-E	
	130	31	192 000	208 000	37 500	6 500	3 600	1,67	–	NUP2215-E-XL-TVP2	–	
	160	37	285 000	265 000	46 500	5 100	4 150	3,39	–	NJ315-E-XL-TVP2	–	
	160	37	285 000	265 000	46 500	5 100	4 150	3,39	0,407	NJ315-E-XL-TVP2	HJ315-E	
	160	37	285 000	265 000	46 500	5 100	4 150	3,45	–	NUP315-E-XL-TVP2	–	
	160	55	390 000	395 000	71 000	5 100	3 550	5,04	–	NJ2315-E-XL-TVP2	–	
	160	55	390 000	395 000	71 000	5 100	3 550	5,04	0,436	NJ2315-E-XL-TVP2	HJ2315-E	
	160	55	390 000	395 000	71 000	5 100	3 550	5,14	–	NUP2315-E-XL-TVP2	–	
	190	45	325 000	295 000	50 000	5 800	4 100	7,21	–	NJ415-XL-M1	–	
190	45	325 000	295 000	50 000	5 800	4 100	7,21	0,737	NJ415-XL-M1	HJ415		
80	140	26	166 000	168 000	29 000	6 100	4 200	1,58	–	NJ216-E-XL-TVP2	–	
	140	26	166 000	168 000	29 000	6 100	4 200	1,58	0,22	NJ216-E-XL-TVP2	HJ216-E	
	140	26	166 000	168 000	29 000	6 100	4 200	1,62	–	NUP216-E-XL-TVP2	–	
	140	33	221 000	244 000	43 500	6 100	3 400	2,04	–	NJ2216-E-XL-TVP2	–	
	140	33	221 000	244 000	43 500	6 100	3 400	2,04	0,22	NJ2216-E-XL-TVP2	HJ216-E	
	140	33	221 000	244 000	43 500	6 100	3 400	2,08	–	NUP2216-E-XL-TVP2	–	
	170	39	300 000	275 000	49 500	4 800	4 100	4,03	–	NJ316-E-XL-TVP2	–	
	170	39	300 000	275 000	49 500	4 800	4 100	4,03	0,456	NJ316-E-XL-TVP2	HJ316-E	
	170	39	300 000	275 000	49 500	4 800	4 100	4,11	–	NUP316-E-XL-TVP2	–	
	170	58	420 000	425 000	78 000	4 800	3 450	6	–	NJ2316-E-XL-TVP2	–	
	170	58	420 000	425 000	78 000	4 800	3 450	6	0,488	NJ2316-E-XL-TVP2	HJ2316-E	
	170	58	420 000	425 000	78 000	4 800	3 450	6,11	–	NUP2316-E-XL-TVP2	–	
	200	48	395 000	365 000	63 000	5 400	3 750	8,52	–	NJ416-XL-M1	–	
200	48	395 000	365 000	63 000	5 400	3 750	8,52	0,808	NJ416-XL-M1	HJ416		

medias ▶ <https://www.schaeffler.de/std/1DAE>

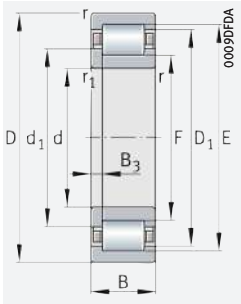

NUP
Locating bearing

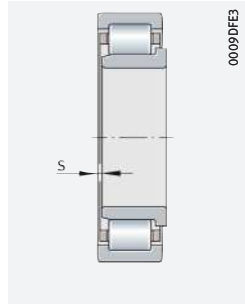

Axial displacement "s"
for NJ

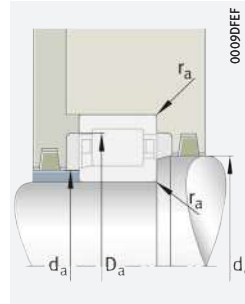

Mounting dimensions
for NJ

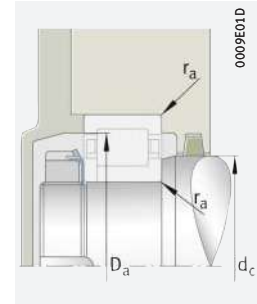

Mounting dimensions
for NUP

Dimensions

Mounting dimensions

d	r	r ₁	s	E	F	D ₁	d ₁	B ₁	B ₂	B ₃	d _a		d _c	D _a	r _a
											min. ¹⁾	max.			
75	1,5	1,5	1,2	118,5	88,5	114,4	94,4	-	-	-	84	87	96	121	1,5
	1,5	1,5	-	118,5	88,5	114,4	94,4	7	11	-	84	-	96	121	1,5
	1,5	1,5	-	118,5	88,5	114,4	94,4	-	-	4	84	-	96	121	1,5
	1,5	1,5	1,6	118,5	88,5	114,4	94,4	-	-	-	84	87	96	121	1,5
	1,5	1,5	-	118,5	88,5	114,4	94,4	7	11,5	-	84	-	96	121	1,5
	1,5	1,5	-	118,5	88,5	114,4	94,4	-	-	4,5	84	-	96	121	1,5
	2,1	2,1	1,2	143	95	136,2	104,1	-	-	-	87	93	106	148	2,1
	2,1	2,1	-	143	95	136,2	104,1	11	16,5	-	87	-	106	148	2,1
	2,1	2,1	-	143	95	136,2	104,1	-	-	5,5	87	-	106	148	2,1
	2,1	2,1	4,2	143	95	136,2	104,1	-	-	-	87	93	106	148	2,1
	2,1	2,1	-	143	95	136,2	104,1	11	19,5	-	87	-	106	148	2,1
	2,1	2,1	-	143	95	136,2	104,1	-	-	8,5	87	-	106	148	2,1
80	3	3	4,5	160,5	104,5	150,7	115,8	-	-	-	91	103	118	174	2,5
	3	3	-	160,5	104,5	150,7	115,8	13	21,5	-	91	-	118	174	2,5
	2	2	1,3	127,3	95,3	122,9	101,5	-	-	-	91	94	104	129	2
	2	2	-	127,3	95,3	122,9	101,5	8	12,5	-	91	-	104	129	2
	2	2	-	127,3	95,3	122,9	101,5	-	-	4,5	91	-	104	129	2
	2	2	1,3	127,3	95,3	122,9	101,5	-	-	-	91	94	104	129	2
	2	2	-	127,3	95,3	122,9	101,5	8	12,5	-	91	-	104	129	2
	2	2	-	127,3	95,3	122,9	101,5	-	-	4,5	91	-	104	129	2
	2,1	2,1	0,7	151	101	143,9	110,4	-	-	-	92	99	114	158	2,1
	2,1	2,1	-	151	101	143,9	110,4	11	17	-	92	-	114	158	2,1
	2,1	2,1	-	151	101	143,9	110,4	-	-	6	92	-	114	158	2,1
	2,1	2,1	3,7	151	101	143,9	110,4	-	-	-	92	99	114	158	2,1
2,1	2,1	-	151	101	143,9	110,4	11	20	-	92	-	114	158	2,1	
2,1	2,1	-	151	101	143,9	110,4	-	-	9	92	-	114	158	2,1	
3	3	4,6	170	110	159,7	121,8	-	-	-	96	109	124	184	2,5	
3	3	-	170	110	159,7	121,8	13	22	-	96	-	124	184	2,5	

¹⁾ Under axial load, observe the dimensions D₁ and d₁.





Cylindrical roller bearings with cage

Semi-locating bearings, locating bearings

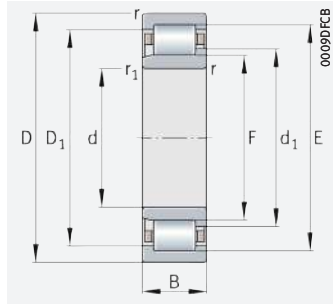

NJ
Semi-locating bearing

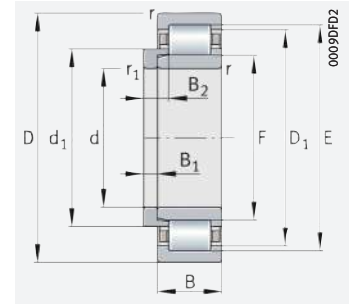

NJ and HJ
Locating bearings

d = 85 – 90 mm

Main dimensions			Basic load ratings		Fatigue limit load C_{ur} N	Limiting speed n_G min^{-1}	Speed rating $n_{\theta r}$ min^{-1}	Mass m		Designation ▶425 1.12 ▶426 1.13 X-life ▶415	Bearing	L-section ring
d	D	B	dyn. C_r N	stat. C_{0r} N				Bearing \approx kg	L-section ring \approx kg			
85	150	28	194 000	194 000	33 500	5 600	4 000	1,95	–	NJ217-E-XL-TVP2	–	
	150	28	194 000	194 000	33 500	5 600	4 000	1,95	0,247	NJ217-E-XL-TVP2	HJ217-E	
	150	28	194 000	194 000	33 500	5 600	4 000	2,08	–	NUP217-E-XL-TVP2	–	
	150	36	255 000	275 000	48 500	5 600	3 300	2,55	–	NJ2217-E-XL-TVP2	–	
	150	36	255 000	275 000	48 500	5 600	3 300	2,55	0,249	NJ2217-E-XL-TVP2	HJ2217-E	
	150	36	255 000	275 000	48 500	5 600	3 300	2,6	–	NUP2217-E-XL-TVP2	–	
	180	41	320 000	300 000	53 000	4 550	3 900	4,71	–	NJ317-E-XL-TVP2	–	
	180	41	320 000	300 000	53 000	4 550	3 900	4,71	0,566	NJ317-E-XL-TVP2	HJ317-E	
	180	41	320 000	300 000	53 000	4 550	3 900	4,8	–	NUP317-E-XL-TVP2	–	
	180	60	435 000	445 000	80 000	4 550	3 300	6,85	–	NJ2317-E-XL-TVP2	–	
	180	60	435 000	445 000	80 000	4 550	3 300	6,85	0,606	NJ2317-E-XL-TVP2	HJ2317-E	
	180	60	435 000	445 000	80 000	4 550	3 300	6,99	–	NUP2317-E-XL-TVP2	–	
210	52	420 000	385 000	66 000	5 200	3 850	10	–	NJ417-XL-M1	–		
210	52	420 000	385 000	66 000	5 200	3 850	10	0,901	NJ417-XL-M1	HJ417		
90	160	30	215 000	217 000	37 000	5 200	3 900	2,41	–	NJ218-E-XL-TVP2	–	
	160	30	215 000	217 000	37 000	5 200	3 900	2,41	0,317	NJ218-E-XL-TVP2	HJ218-E	
	160	30	215 000	217 000	37 000	5 200	3 900	2,46	–	NUP218-E-XL-TVP2	–	
	160	40	285 000	315 000	55 000	5 200	3 250	3,23	–	NJ2218-E-XL-TVP2	–	
	160	40	285 000	315 000	55 000	5 200	3 250	3,23	0,323	NJ2218-E-XL-TVP2	HJ2218-E	
	160	40	285 000	315 000	55 000	5 200	3 250	3,29	–	NUP2218-E-XL-TVP2	–	
	190	43	370 000	350 000	59 000	4 250	3 650	5,49	–	NJ318-E-XL-TVP2	–	
	190	43	370 000	350 000	59 000	4 250	3 650	5,49	0,623	NJ318-E-XL-TVP2	HJ318-E	
	190	43	370 000	350 000	59 000	4 250	3 650	5,59	–	NUP318-E-XL-TVP2	–	
	190	64	510 000	530 000	92 000	4 250	3 000	8,19	–	NJ2318-E-XL-TVP2	–	
	190	64	510 000	530 000	92 000	4 250	3 000	8,19	0,669	NJ2318-E-XL-TVP2	HJ2318-E	
	190	64	510 000	530 000	92 000	4 250	3 000	8,35	–	NUP2318-E-XL-TVP2	–	
225	54	465 000	425 000	73 000	4 800	3 500	11,8	–	NJ418-XL-M1	–		
225	54	465 000	425 000	73 000	4 800	3 500	11,8	1,1	NJ418-XL-M1	HJ418		

medias ▶ <https://www.schaeffler.de/std/1DAF>

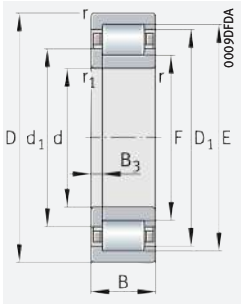

NUP
Locating bearing

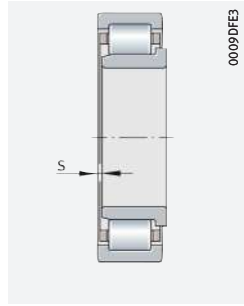

Axial displacement "s"
for NJ

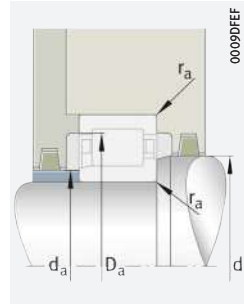

Mounting dimensions
for NJ

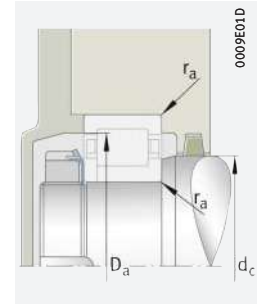

Mounting dimensions
for NUP

Dimensions

Mounting dimensions

d	r	r ₁ min.	s	E	F	D ₁ ≈	d ₁ ≈	B ₁	B ₂	B ₃	d _a		d _c	D _a	r _a	
											min. ¹⁾	max.				
85	2	2	0,8	136,5	100,5	131,5	107,5	-	-	-	96	99	110	139	2	
	2	2	-	136,5	100,5	131,5	107,5	8	12,5	-	96	-	110	139	2	
	2	2	-	136,5	100,5	131,5	107,5	-	-	4,5	96	-	110	139	2	
	2	2	1,3	136,5	100,5	131,5	107,5	-	-	-	96	99	110	139	2	
	2	2	-	136,5	100,5	131,5	107,5	8	13	-	96	-	110	139	2	
	2	2	-	136,5	100,5	131,5	107,5	-	-	5	96	-	110	139	2	
	3	3	1,3	160	108	152,7	117,8	-	-	-	99	106	119	166	2,5	
	3	3	-	160	108	152,7	117,8	12	18,5	-	99	-	119	166	2,5	
	3	3	-	160	108	152,7	117,8	-	-	6,5	99	-	119	166	2,5	
	3	3	4,7	160	108	152,7	117,8	-	-	-	99	106	119	166	2,5	
	3	3	-	160	108	152,7	117,8	12	22	-	99	-	119	166	2,5	
	3	3	-	160	108	152,7	117,8	-	-	10	99	-	119	166	2,5	
90	4	4	5,2	177	113	165,7	125,8	-	-	-	105	111	128	190	3	
	4	4	-	177	113	165,7	125,8	14	24	-	105	-	128	190	3	
	90	2	2	1,5	145	107	139,7	114,3	-	-	-	101	105	116	149	2
		2	2	-	145	107	139,7	114,3	9	14	-	101	-	116	149	2
		2	2	-	145	107	139,7	114,3	-	-	5	101	-	116	149	2
		2	2	2,5	145	107	139,7	114,3	-	-	-	101	105	116	149	2
		2	2	-	145	107	139,7	114,3	9	15	-	101	-	116	149	2
		2	2	-	145	107	139,7	114,3	-	-	6	101	-	116	149	2
		3	3	1,5	169,5	113,5	161,6	124	-	-	-	104	111	127	176	2,5
		3	3	-	169,5	113,5	161,6	124	12	18,5	-	104	-	127	176	2,5
		3	3	-	169,5	113,5	161,6	124	-	-	6,5	104	-	127	176	2,5
		3	3	5	169,5	113,5	161,6	124	-	-	-	104	111	127	176	2,5
3		3	-	169,5	113,5	161,6	124	12	22	-	104	-	127	176	2,5	
3		3	-	169,5	113,5	161,6	124	-	-	10	104	-	127	176	2,5	

¹⁾ Under axial load, observe the dimensions D₁ and d₁.



Cylindrical roller bearings with cage

Semi-locating bearings, locating bearings

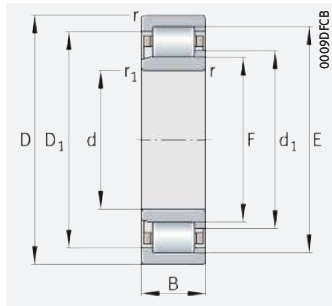

NJ
Semi-locating bearing

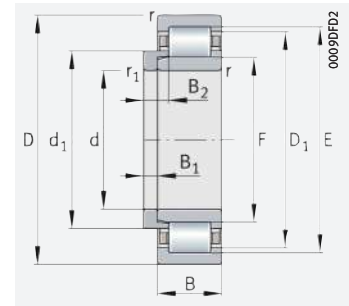

NJ and HJ
Locating bearings

d = 95 – 105 mm

Main dimensions			Basic load ratings		Fatigue limit load C_{ur} N	Limiting speed n_G min^{-1}	Speed rating n_{0r} min^{-1}	Mass m		Designation ▶425 1.12 ▶426 1.13 X-life ▶415	
d	D	B	dyn. C_r N	stat. C_{Or} N				Bearing \approx kg	L-section ring \approx kg	Bearing	L-section ring
95	170	32	260 000	265 000	44 000	4 850	3 650	2,94	–	NJ219-E-XL-TVP2	–
	170	32	260 000	265 000	44 000	4 850	3 650	2,94	0,352	NJ219-E-XL-TVP2	HJ219-E
	170	32	260 000	265 000	44 500	4 850	3 650	2,99	–	NUP219-E-XL-TVP2	–
	170	43	340 000	370 000	64 000	4 850	3 050	3,98	–	NJ2219-E-XL-TVP2	–
	170	43	340 000	370 000	64 000	4 850	3 050	3,98	0,366	NJ2219-E-XL-TVP2	HJ2219-E
	170	43	340 000	370 000	64 000	4 850	3 050	4,05	–	NUP2219-E-XL-TVP2	–
	200	45	390 000	380 000	64 000	4 050	3 550	6,44	–	NJ319-E-XL-TVP2	–
	200	45	390 000	380 000	64 000	4 050	3 550	6,44	0,777	NJ319-E-XL-TVP2	HJ319-E
	200	45	390 000	380 000	64 000	4 050	3 550	6,56	–	NUP319-E-XL-TVP2	–
	200	67	540 000	580 000	99 000	4 050	2 800	9,58	–	NJ2319-E-XL-TVP2	–
	200	67	540 000	580 000	99 000	4 050	2 800	9,58	0,83	NJ2319-E-XL-TVP2	HJ2319-E
	200	67	540 000	580 000	99 000	4 050	2 800	9,77	–	NUP2319-E-XL-TVP2	–
	240	55	495 000	470 000	79 000	4 550	3 200	14,1	–	NJ419-XL-M1	–
240	55	495 000	470 000	79 000	4 550	3 200	14,1	1,36	NJ419-XL-M1	HJ419	
100	180	34	295 000	305 000	51 000	4 550	3 450	3,55	–	NJ220-E-XL-TVP2	–
	180	34	295 000	305 000	51 000	4 550	3 450	3,55	0,436	NJ220-E-XL-TVP2	HJ220-E
	180	34	295 000	305 000	51 000	4 550	3 450	3,61	–	NUP220-E-XL-TVP2	–
	180	46	395 000	445 000	76 000	4 550	2 900	4,85	–	NJ2220-E-XL-TVP2	–
	180	46	395 000	445 000	76 000	4 550	2 900	4,85	0,446	NJ2220-E-XL-TVP2	HJ2220-E
	180	46	395 000	445 000	76 000	4 550	2 900	4,92	–	NUP2220-E-XL-TVP2	–
	215	47	450 000	425 000	71 000	3 700	3 350	7,82	–	NJ320-E-XL-TVP2	–
	215	47	450 000	425 000	71 000	3 700	3 350	7,82	0,883	NJ320-E-XL-TVP2	HJ320-E
	215	47	450 000	425 000	71 000	3 700	3 350	7,96	–	NUP320-E-XL-TVP2	–
	215	73	680 000	720 000	123 000	3 700	2 500	12,3	–	NJ2320-E-XL-TVP2	–
	215	73	680 000	720 000	123 000	3 700	2 500	12,3	0,934	NJ2320-E-XL-TVP2	HJ2320-E
	215	73	680 000	720 000	123 000	3 700	2 500	12,5	–	NUP2320-E-XL-TVP2	–
	250	58	550 000	530 000	86 000	4 350	2 950	16,1	–	NJ420-XL-M1	–
250	58	550 000	530 000	86 000	4 350	2 950	16,1	1,55	NJ420-XL-M1	HJ420	
105	190	36	310 000	320 000	53 000	4 350	3 400	4,17	–	NJ221-E-XL-TVP2	–
	190	36	310 000	320 000	53 000	4 350	3 400	4,17	0,51	NJ221-E-XL-TVP2	HJ221-E
	190	36	310 000	320 000	53 000	4 350	3 400	4,26	–	NUP221-E-XL-TVP2	–
	260	60	610 000	590 000	96 000	4 150	2 750	18	–	NJ421-XL-M1	–
	260	60	610 000	590 000	96 000	4 150	2 750	18	1,65	NJ421-XL-M1	HJ421

medias ▶ <https://www.schaeffler.de/std/1DB0>

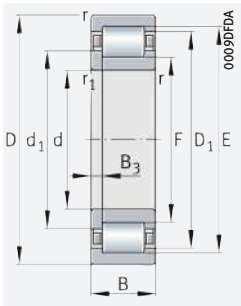

NUP
Locating bearing

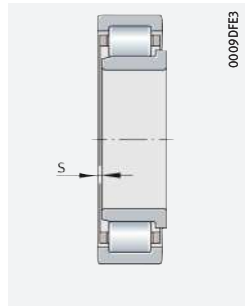

Axial displacement "s"
for NJ

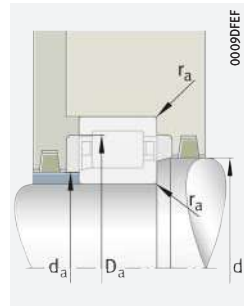

Mounting dimensions
for NJ

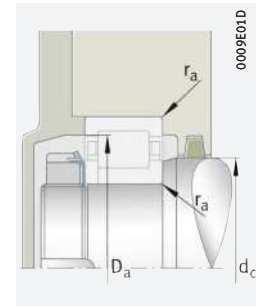

Mounting dimensions
for NUP

Dimensions

Mounting dimensions

d	r	r ₁	s	E	F	D ₁	d ₁	B ₁	B ₂	B ₃	d _a		d _c	D _a	r _a
											min. ¹⁾	max.			
95	2,1	2,1	0,7	154,5	112,5	148,6	120,5	-	-	-	107	111	123	158	2,1
	2,1	2,1	-	154,5	112,5	148,6	120,5	9	14	-	107	-	123	158	2,1
	2,1	2,1	-	154,5	112,5	148,6	120,5	-	-	5	107	-	123	158	2,1
	2,1	2,1	2,2	154,5	112,5	148,6	120,5	-	-	-	107	111	123	158	2,1
	2,1	2,1	-	154,5	112,5	148,6	120,5	9	15,5	-	107	-	123	158	2,1
	2,1	2,1	-	154,5	112,5	148,6	120,5	-	-	6,5	107	-	123	158	2,1
	3	3	1,4	177,5	121,5	169,6	132	-	-	-	109	119	134	186	2,5
	3	3	-	177,5	121,5	169,6	132	13	20,5	-	109	-	134	186	2,5
	3	3	-	177,5	121,5	169,6	132	-	-	7,5	109	-	134	186	2,5
	3	3	5,6	177,5	121,5	169,6	132	-	-	-	109	119	134	186	2,5
	3	3	-	177,5	121,5	169,6	132	13	24,5	-	109	-	134	186	2,5
	3	3	-	177,5	121,5	169,6	132	-	-	11,5	109	-	134	186	2,5
	4	4	5,2	201,5	133,5	189,7	146,8	-	-	-	115	132	149	220	3
4	4	-	201,5	133,5	189,7	146,8	15	25,5	-	115	-	149	220	3	
100	2,1	2,1	1,5	163	119	156,9	127,3	-	-	-	112	117	130	168	2,1
	2,1	2,1	-	163	119	156,9	127,3	10	15	-	112	-	130	168	2,1
	2,1	2,1	-	163	119	156,9	127,3	-	-	5	112	-	130	168	2,1
	2,1	2,1	3	163	119	156,9	127,3	-	-	-	112	117	130	168	2,1
	2,1	2,1	-	163	119	156,9	127,3	10	16	-	112	-	130	168	2,1
	2,1	2,1	-	163	119	156,9	127,3	-	-	6	112	-	130	168	2,1
	3	3	1,2	191,5	127,5	182	139,4	-	-	-	114	125	143	201	2,5
	3	3	-	191,5	127,5	182	139,4	13	20,5	-	114	-	143	201	2,5
	3	3	-	191,5	127,5	182	139,4	-	-	7,5	114	-	143	201	2,5
	3	3	4,2	191,5	127,5	182	139,4	-	-	-	114	125	143	201	2,5
	3	3	-	191,5	127,5	182	139,4	13	23,5	-	114	-	143	201	2,5
	3	3	-	191,5	127,5	182	139,4	-	-	10,5	114	-	143	201	2,5
	4	4	5,7	211	139	198,2	152,8	-	-	-	120	137	156	230	3
4	4	-	211	139	198,2	152,8	16	27	-	120	-	156	230	3	
105	2,1	2,1	1,3	171,5	125,5	165,1	134,5	-	-	-	117	123	137	178	2,1
	2,1	2,1	-	171,5	125,5	165,1	134,5	10	16	-	117	-	137	178	2,1
	2,1	2,1	-	171,5	125,5	165,1	134,5	-	-	6	117	-	137	178	2,1
	4	4	5,7	220,5	144,5	207,4	158,8	-	-	-	125	143	162	240	3
	4	4	-	220,5	144,5	207,4	158,8	16	27	-	125	-	162	240	3

¹⁾ Under axial load, observe the dimensions D₁ and d₁.

Cylindrical roller bearings with cage

Semi-locating bearings, locating bearings

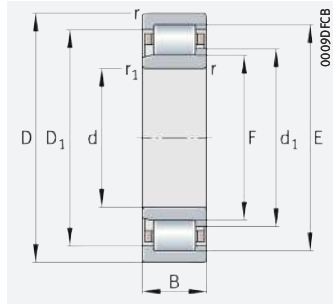

NJ
Semi-locating bearing

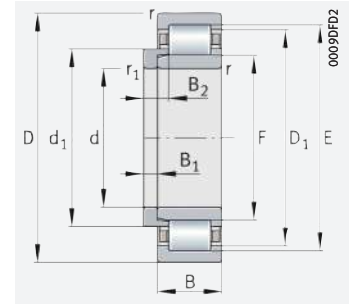

NJ and HJ
Locating bearings

d = 110 – 120 mm

Main dimensions			Basic load ratings		Fatigue limit load	Limiting speed	Speed rating	Mass m		Designation	
d	D	B	dyn. Cr	stat. Cor	Cur	nG	nGr	Bearing	L-section ring	Bearing	L-section ring
			N	N	N	min ⁻¹	min ⁻¹	≈ kg	≈ kg		
110	200	38	345 000	365 000	59 000	4 100	3 250	4,93	–	NJ222-E-XL-TVP2	–
	200	38	345 000	365 000	59 000	4 100	3 250	4,93	0,616	NJ222-E-XL-TVP2	HJ222-E
	200	38	345 000	365 000	59 000	4 100	3 250	5,02	–	NUP222-E-XL-TVP2	–
	200	53	455 000	520 000	86 000	4 100	2 750	6,89	–	NJ2222-E-XL-TVP2	–
	200	53	455 000	520 000	86 000	4 100	2 750	6,89	0,647	NJ2222-E-XL-TVP2	HJ2222-E
	200	53	455 000	520 000	86 000	4 100	2 750	7,02	–	NUP2222-E-XL-TVP2	–
	240	50	495 000	475 000	79 000	3 350	3 050	10,3	–	NJ322-E-XL-TVP2	–
	240	50	495 000	475 000	79 000	3 350	3 050	10,3	1,21	NJ322-E-XL-TVP2	HJ322-E
	240	50	495 000	475 000	79 000	3 350	3 050	10,7	–	NUP322-E-XL-TVP2	–
	240	80	750 000	800 000	136 000	3 350	2 290	16,9	–	NJ2322-E-XL-TVP2	–
	240	80	750 000	800 000	136 000	3 350	2 290	16,9	1,3	NJ2322-E-XL-TVP2	HJ2322-E
	240	80	750 000	800 000	135 000	3 350	2 290	17,2	–	NUP2322-E-XL-TVP2	–
	280	65	680 000	660 000	105 000	3 850	2 550	22,8	–	NJ422-XL-M1	–
	280	65	680 000	660 000	105 000	3 850	2 550	22,8	2,1	NJ422-XL-M1	HJ422
120	215	40	390 000	415 000	68 000	3 750	3 050	5,91	–	NJ224-E-XL-TVP2	–
	215	40	390 000	415 000	68 000	3 750	3 050	5,91	0,707	NJ224-E-XL-TVP2	HJ224-E
	215	40	390 000	415 000	68 000	3 750	3 050	6,02	–	NUP224-E-XL-TVP2	–
	215	58	530 000	610 000	103 000	3 750	2 500	8,54	–	NJ2224-E-XL-TVP2	–
	215	58	530 000	610 000	103 000	3 750	2 500	8,54	0,75	NJ2224-E-XL-TVP2	HJ2224-E
	215	58	530 000	610 000	102 000	3 750	2 500	8,7	–	NUP2224-E-XL-TVP2	–
	260	55	610 000	600 000	96 000	3 050	2 650	13,5	–	NJ324-E-XL-TVP2	–
	260	55	610 000	600 000	96 000	3 050	2 650	13,5	1,41	NJ324-E-XL-TVP2	HJ324-E
	260	55	610 000	600 000	95 000	3 050	2 650	13,8	–	NUP324-E-XL-TVP2	–
	260	86	930 000	1 010 000	166 000	3 950	1 980	23,8	–	NJ2324-E-XL-M1	–
	260	86	930 000	1 010 000	166 000	3 950	1 980	23,8	1,49	NJ2324-E-XL-M1	HJ2324-E
	260	86	930 000	1 010 000	165 000	3 950	1 980	24,1	–	NUP2324-E-XL-M1	–
	310	72	850 000	840 000	129 000	3 450	2 200	31,3	–	NJ424-XL-M1	–
	310	72	850 000	840 000	129 000	3 450	2 200	31,3	2,61	NJ424-XL-M1	HJ424

medias ► <https://www.schaeffler.de/std/1DB1>

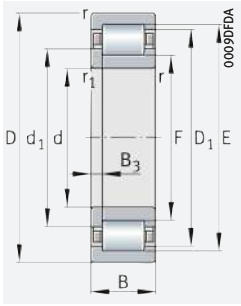

NUP
Locating bearing

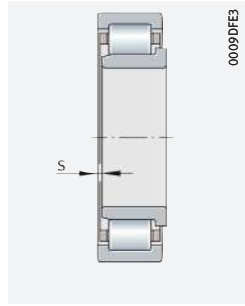

Axial displacement "s"
for NJ

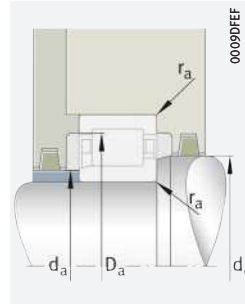

Mounting dimensions
for NJ

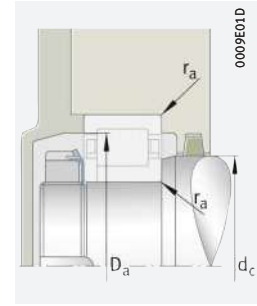

Mounting dimensions
for NUP

Dimensions

Mounting dimensions

d	r	r ₁	s	E	F	D ₁	d ₁	B ₁	B ₂	B ₃	d _a		d _c	D _a	r _a
											min. ¹⁾	max.			
110	2,1	2,1	1,5	180,5	132,5	173,8	141,6	-	-	-	122	130	144	188	2,1
	2,1	2,1	-	180,5	132,5	173,8	141,6	11	17	-	122	-	144	188	2,1
	2,1	2,1	-	180,5	132,5	173,8	141,6	-	-	6	122	-	144	188	2,1
	2,1	2,1	4	180,5	132,5	173,8	141,6	-	-	-	122	130	144	188	2,1
	2,1	2,1	-	180,5	132,5	173,8	141,6	11	19,5	-	122	-	144	188	2,1
	2,1	2,1	-	180,5	132,5	173,8	141,6	-	-	8,5	122	-	144	188	2,1
	3	3	1,3	211	143	200,9	155,6	-	-	-	124	140	158	226	2,5
	3	3	-	211	143	200,9	155,6	14	22	-	124	-	158	226	2,5
	3	3	-	211	143	200,9	155,6	-	-	8	124	-	158	226	2,5
	3	3	5,8	211	143	200,9	155,6	-	-	-	124	140	158	226	2,5
	3	3	-	211	143	200,9	155,6	14	26,5	-	124	-	158	226	2,5
	3	3	-	211	143	200,9	155,6	-	-	12,5	124	-	158	226	2,5
	4	4	6,2	235	155	220,9	170,3	-	-	-	130	153	173	260	3
4	4	-	235	155	220,9	170,3	17	29,5	-	130	-	173	260	3	
120	2,1	2,1	1,4	195,5	143,5	187,8	153,2	-	-	-	132	141	156	203	2,1
	2,1	2,1	-	195,5	143,5	187,8	153,2	11	17	-	132	-	156	203	2,1
	2,1	2,1	-	195,5	143,5	187,8	153,2	-	-	6	132	-	156	203	2,1
	2,1	2,1	4,5	195,5	143,5	187,8	153,2	-	-	-	132	141	156	203	2,1
	2,1	2,1	-	195,5	143,5	187,8	153,2	11	20	-	132	-	156	203	2,1
	2,1	2,1	-	195,5	143,5	187,8	153,2	-	-	9	132	-	156	203	2,1
	3	3	3,5	230	154	218,7	168,1	-	-	-	134	151	171	246	2,5
	3	3	-	230	154	218,7	168,1	14	22,5	-	134	-	171	246	2,5
	3	3	-	230	154	218,7	168,1	-	-	8,5	134	-	171	246	2,5
	3	3	7,2	230	154	218,7	168,1	-	-	-	134	151	171	246	2,5
	3	3	-	230	154	218,7	168,1	14	26	-	134	-	171	246	2,5
	3	3	-	230	154	218,7	168,1	-	-	12	134	-	171	246	2,5
	5	5	6,9	260	170	243,9	187,3	-	-	-	144	168	190	286	4
5	5	-	260	170	243,9	187,3	17	30,5	-	144	-	190	286	4	

¹⁾ Under axial load, observe the dimensions D₁ and d₁.





Cylindrical roller bearings with cage

Semi-locating bearings, locating bearings

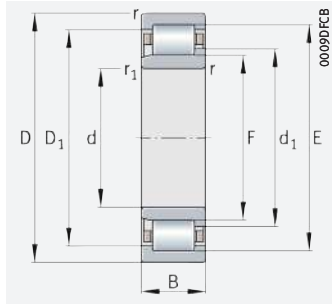

NJ
Semi-locating bearing

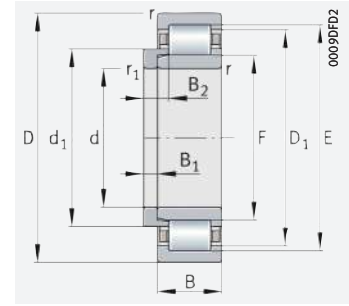

NJ and HJ
Locating bearings

d = 130 – 140 mm

Main dimensions			Basic load ratings		Fatigue limit load C_{ur} N	Limiting speed n_G min^{-1}	Speed rating n_{gr} min^{-1}	Mass m		Designation	
d	D	B	dyn. C_r N	stat. C_{0r} N				Bearing \approx kg	L-section ring \approx kg	Bearing	L-section ring
130	230	40	425 000	445 000	70 000	3 500	2 800	6,63	–	NJ226-E-XL-TVP2	–
	230	40	425 000	445 000	70 000	3 500	2 800	6,63	0,78	NJ226-E-XL-TVP2	HJ226-E
	230	40	425 000	445 000	70 000	3 500	2 800	6,74	–	NUP226-E-XL-TVP2	–
	230	64	620 000	730 000	118 000	3 500	2 280	10,6	–	NJ2226-E-XL-TVP2	–
	230	64	620 000	730 000	118 000	3 500	2 280	10,6	0,849	NJ2226-E-XL-TVP2	HJ2226-E
	230	64	620 000	730 000	118 000	3 500	2 280	10,8	–	NUP2226-E-XL-TVP2	–
	280	58	680 000	670 000	105 000	2 850	2 430	16,5	–	NJ326-E-XL-TVP2	–
	280	58	680 000	670 000	105 000	2 850	2 430	16,5	1,64	NJ326-E-XL-TVP2	HJ326-E
	280	58	680 000	670 000	105 000	2 850	2 430	16,7	–	NUP326-E-XL-TVP2	–
	280	93	1 080 000	1 220 000	195 000	3 700	1 750	29,2	–	NJ2326-E-XL-M1	–
	280	93	1 080 000	1 220 000	195 000	3 700	1 750	29,2	1,77	NJ2326-E-XL-M1	HJ2326-E
	280	93	1 080 000	1 220 000	194 000	3 700	1 750	29,7	–	NUP2326-E-XL-M1	–
140	250	42	460 000	510 000	78 000	4 250	2 600	9,46	–	NJ228-E-XL-M1	–
	250	42	460 000	510 000	78 000	4 250	2 600	9,46	0,986	NJ228-E-XL-M1	HJ228-E
	250	42	460 000	510 000	77 000	4 250	2 600	9,61	–	NUP228-E-XL-M1	–
	250	68	670 000	830 000	131 000	4 250	2 050	14,7	–	NJ2228-E-XL-M1	–
	250	68	670 000	830 000	131 000	4 250	2 050	14,7	1,08	NJ2228-E-XL-M1	HJ2228-E
	250	68	670 000	830 000	131 000	4 250	2 050	16,8	–	NUP2228-E-XL-M1	–
	300	62	790 000	800 000	124 000	2 650	2 170	20,5	–	NJ328-E-XL-TVP2	–
	300	62	790 000	800 000	124 000	2 650	2 170	20,5	2,03	NJ328-E-XL-TVP2	HJ328-E
	300	62	790 000	800 000	124 000	2 650	2 170	20,8	–	NUP328-E-XL-TVP2	–
	300	102	1 210 000	1 390 000	219 000	3 450	1 620	36,6	–	NJ2328-E-XL-M1	–
	300	102	1 210 000	1 390 000	219 000	3 450	1 620	36,6	2,2	NJ2328-E-XL-M1	HJ2328-E
	300	102	1 210 000	1 390 000	217 000	3 450	1 620	37,1	–	NUP2328-E-XL-M1	–

medias ► <https://www.schaeffler.de/std/1DB2>

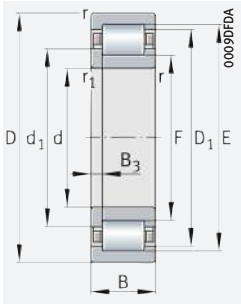

NUP
Locating bearing

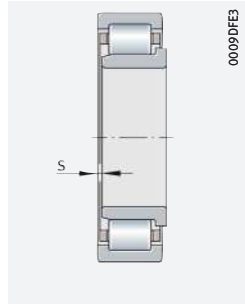

Axial displacement "s"
for NJ

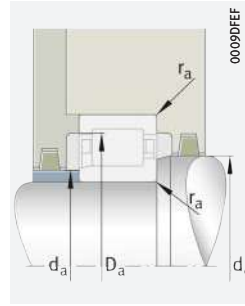

Mounting dimensions
for NJ

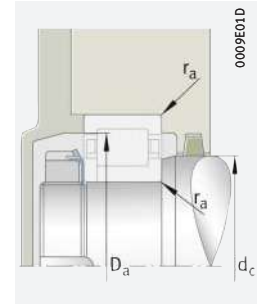

Mounting dimensions
for NUP

Dimensions

Mounting dimensions

d	r	r ₁ min.	s	E	F	D ₁ ≈	d ₁ ≈	B ₁	B ₂	B ₃	d _a		d _c min.	D _a max. ¹⁾	r _a max.
											min. ¹⁾	max.			
130	3	3	1,2	209,5	153,5	201,2	164	-	-	-	144	151	168	216	2,5
	3	3	-	209,5	153,5	201,2	164	11	17	-	144	-	168	216	2,5
	3	3	-	209,5	153,5	201,2	164	-	-	6	144	-	168	216	2,5
	3	3	5,2	209,5	153,5	201,2	164	-	-	-	144	151	168	216	2,5
	3	3	-	209,5	153,5	201,2	164	11	21	-	144	-	168	216	2,5
	3	3	-	209,5	153,5	201,2	164	-	-	10	144	-	168	216	2,5
	4	4	3,5	247	167	235,2	181,7	-	-	-	147	164	184	263	3
	4	4	-	247	167	235,2	181,7	14	23	-	147	-	184	263	3
	4	4	-	247	167	235,2	181,7	-	-	9	147	-	184	263	3
	4	4	8,1	247	167	235,2	181,7	-	-	-	147	164	184	263	3
	4	4	-	247	167	235,2	181,7	14	28	-	147	-	184	263	3
	4	4	-	247	167	235,2	181,7	-	-	14	147	-	184	263	3
140	3	3	3,8	225	169	216,7	179,4	-	-	-	154	166	182	236	2,5
	3	3	-	225	169	216,7	179,4	11	18	-	154	-	182	236	2,5
	3	3	-	225	169	216,7	179,4	-	-	7	154	-	182	236	2,5
	3	3	7	225	169	216,7	179,4	-	-	-	154	166	182	236	2,5
	3	3	-	225	169	216,7	179,4	11	23	-	154	-	182	236	2,5
	3	3	-	225	169	216,7	179,4	-	-	12	154	-	182	236	2,5
	4	4	5,2	264	180	251,7	195,4	-	-	-	157	176	198	283	3
	4	4	-	264	180	251,7	195,4	15	25	-	157	-	198	283	3
	4	4	-	264	180	251,7	195,4	-	-	10	157	-	198	283	3
	4	4	9,2	264	180	251,7	195,4	-	-	-	157	176	198	283	3
	4	4	-	264	180	251,7	195,4	15	31	-	157	-	198	283	3
	4	4	-	264	180	251,7	195,4	-	-	16	157	-	198	283	3

¹⁾ Under axial load, observe the dimensions D₁ and d₁.



Cylindrical roller bearings with cage

Semi-locating bearings, locating bearings

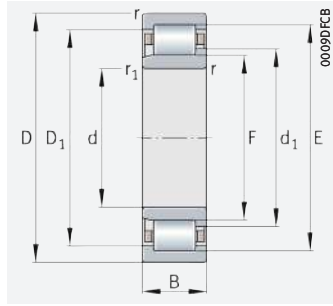

NJ
Semi-locating bearing

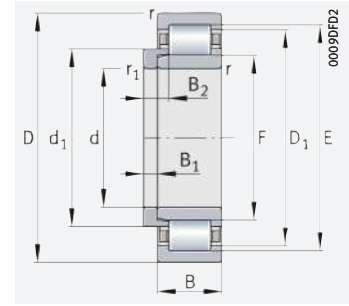

NJ and HJ
Locating bearings

d = 150 – 170 mm

Main dimensions			Basic load ratings		Fatigue limit load C_{ur} N	Limiting speed n_G min^{-1}	Speed rating n_{dr} min^{-1}	Mass m		Designation	
d	D	B	dyn. C_r N	stat. C_{0r} N				Bearing \approx kg	L-section ring \approx kg	Bearing	L-section ring
150	270	45	520 000	590 000	89 000	3 950	2 350	12	–	NJ230-E-XL-M1	
	270	45	520 000	590 000	89 000	3 950	2 350	12	1,26	NJ230-E-XL-M1	HJ230-E
	270	45	520 000	590 000	89 000	3 950	2 350	12,2	–	NUP230-E-XL-M1	
	270	73	780 000	970 000	152 000	3 950	1 850	18,9	–	NJ2230-E-XL-M1	
	270	73	780 000	970 000	152 000	3 950	1 850	18,9	1,36	NJ2230-E-XL-M1	HJ2230-E
	270	73	780 000	970 000	152 000	3 950	1 850	19,2	–	NUP2230-E-XL-M1	
	320	65	900 000	930 000	139 000	3 200	1 940	27,4	–	NJ330-E-XL-M1	
	320	65	900 000	930 000	139 000	3 200	1 940	27,4	2,33	NJ330-E-XL-M1	HJ330-E
	320	65	900 000	930 000	138 000	3 200	1 940	27,8	–	NUP330-E-XL-M1	
	320	108	1 380 000	1 600 000	246 000	3 200	1 460	44,1	–	NJ2330-E-XL-M1	
	320	108	1 380 000	1 600 000	246 000	3 200	1 460	44,1	2,55	NJ2330-E-XL-M1	HJ2330-E
	320	108	1 380 000	1 600 000	245 000	3 200	1 460	44,8	–	NUP2330-E-XL-M1	
160	290	48	590 000	670 000	101 000	3 650	2 160	14,9	–	NJ232-E-XL-M1	
	290	48	590 000	670 000	101 000	3 650	2 160	14,9	1,47	NJ232-E-XL-M1	HJ232-E
	290	48	590 000	670 000	101 000	3 650	2 160	15,2	–	NUP232-E-XL-M1	
	290	80	940 000	1 170 000	184 000	3 600	1 660	24,1	–	NJ2232-E-XL-M1	
	290	80	940 000	1 170 000	184 000	3 600	1 660	24,1	1,56	NJ2232-E-XL-M1	HJ2232-E
	290	80	940 000	1 170 000	183 000	3 600	1 660	24,5	–	NUP2232-E-XL-M1	
	340	68	860 000	1 060 000	128 000	3 000	1 770	32,3	–	NJ332-E-M1	
	340	68	860 000	1 060 000	128 000	3 000	1 770	32,3	2,58	NJ332-E-M1	HJ332-E
	340	114	1 300 000	1 800 000	225 000	3 000	1 350	52,3	–	NJ2332-E-M1	
340	114	1 300 000	1 800 000	225 000	3 000	1 350	52,3	2,85	NJ2332-E-M1	HJ2332-E	
170	310	52	700 000	780 000	117 000	3 350	1 970	18,4	–	NJ234-E-XL-M1	
	310	52	700 000	780 000	117 000	3 350	1 970	18,4	1,58	NJ234-E-XL-M1	HJ234-E
	310	52	700 000	780 000	116 000	3 350	1 970	18,6	–	NUP234-E-XL-M1	
	310	86	1 130 000	1 400 000	213 000	3 300	1 470	29,8	–	NJ2234-E-XL-M1	
	310	86	1 130 000	1 400 000	213 000	3 300	1 470	29,8	1,78	NJ2234-E-XL-M1	HJ2234-E
	310	86	1 130 000	1 400 000	212 000	3 300	1 470	30,2	–	NUP2234-E-XL-M1	
	360	72	960 000	1 210 000	138 000	2 800	1 610	38,6	–	NJ334-E-TB-M1	
	360	72	960 000	1 210 000	138 000	2 800	1 610	38,6	3,21	NJ334-E-TB-M1	HJ334-E
	360	120	1 490 000	2 070 000	227 000	2 800	1 210	62,3	–	NJ2334-EX-TB-M1	
	360	120	1 490 000	2 070 000	227 000	2 800	1 210	62,3	3,53	NJ2334-EX-TB-M1	HJ2334-E

medias ► <https://www.schaeffler.de/std/1DB3>

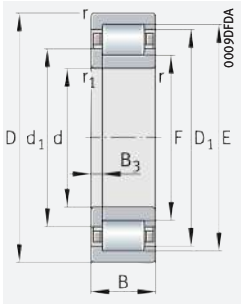

NUP
Locating bearing

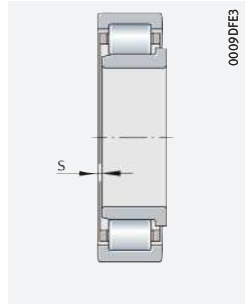

Axial displacement "s"
for NJ

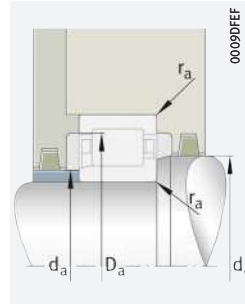

Mounting dimensions
for NJ

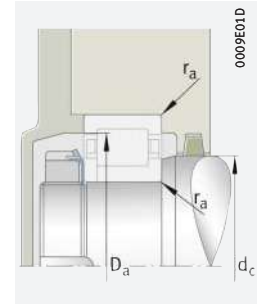

Mounting dimensions
for NUP

Dimensions

Mounting dimensions

d	r	r ₁ min.	s	E	F	D ₁ ≈	d ₁ ≈	B ₁	B ₂	B ₃	Mounting dimensions				
											d _a		d _c	D _a	r _a
											min. ¹⁾	max.			
150	3	3	4	242	182	233,2	193,1	-	-	-	164	179	196	256	2,5
	3	3	-	242	182	233,2	193,1	12	19,5	-	164	-	196	256	2,5
	3	3	-	242	182	233,2	193,1	-	-	7,5	164	-	196	256	2,5
	3	3	7,5	242	182	233,2	193,1	-	-	-	164	179	196	256	2,5
	3	3	-	242	182	233,2	193,1	12	24,5	-	164	-	196	256	2,5
	3	3	-	242	182	233,2	193,1	-	-	12,5	164	-	196	256	2,5
	4	4	5,5	283	193	269,8	209,5	-	-	-	167	190	213	303	3
	4	4	-	283	193	269,8	209,5	15	25	-	167	-	213	303	3
	4	4	-	283	193	269,8	209,5	-	-	10	167	-	213	303	3
	4	4	9,7	283	193	269,8	209,5	-	-	-	167	190	213	303	3
4	4	-	283	193	269,8	209,5	15	31,5	-	167	-	213	303	3	
4	4	-	283	193	269,8	209,5	-	-	16,5	167	-	213	303	3	
160	3	3	4,1	259	195	249,6	206,8	-	-	-	174	192	210	276	2,5
	3	3	-	259	195	249,6	206,8	12	20	-	174	-	210	276	2,5
	3	3	-	259	195	249,6	206,8	-	-	8	174	-	210	276	2,5
	3	3	7,2	261	193	251,1	205,5	-	-	-	174	192	210	276	2,5
	3	3	-	261	193	251,1	205,5	12	24,5	-	174	-	210	276	2,5
	3	3	-	261	193	251,1	205,5	-	-	12,5	174	-	210	276	2,5
	4	4	5,6	300	204	286	221,6	-	-	-	177	200	228	323	3
	4	4	-	300	204	286	221,6	15	25	-	177	-	228	323	3
	4	4	9,9	300	204	286	221,6	-	-	-	177	200	228	323	3
	4	4	-	300	204	286	221,6	15	32	-	177	-	228	323	3
170	4	4	4,3	279	207	268,5	218,4	-	-	-	187	204	223	293	3
	4	4	-	279	207	268,5	218,4	12	20	-	187	-	223	293	3
	4	4	-	279	207	268,5	218,4	-	-	8	187	-	223	293	3
	4	4	7,2	281	205	269,9	219	-	-	-	187	204	223	293	3
	4	4	-	281	205	269,9	219	12	24	-	187	-	223	293	3
	4	4	-	281	205	269,9	219	-	-	12	187	-	223	293	3
	4	4	6	-	218	298	238	-	-	-	187	215	240	343	3
	4	4	-	-	218	298	238	16	27	-	187	-	240	343	3
	4	4	10,2	-	216	299,2	236,8	-	-	-	187	214	238,3	343	3
	4	4	-	-	216	299,2	236,8	16	33,5	-	187	-	238,3	343	3

¹⁾ Under axial load, observe the dimensions D₁ and d₁.

Cylindrical roller bearings with cage

Semi-locating bearings, locating bearings

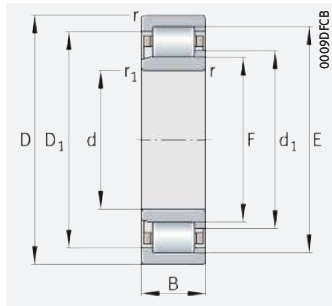

NJ
Semi-locating bearing

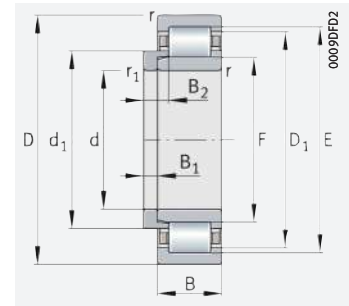

NJ and HJ
Locating bearings

d = 180 – 200 mm

Main dimensions			Basic load ratings		Fatigue limit load C_{ur} N	Limiting speed n_G min^{-1}	Speed rating $n_{\varnothing r}$ min^{-1}	Mass m		Designation	
d	D	B	dyn. C_r N	stat. C_{Or} N				Bearing \approx kg	L-section ring \approx kg	Bearing	L-section ring
180	320	52	730 000	830 000	122 000	3 250	1 850	19,2	–	NJ236-E-XL-M1	–
	320	52	730 000	830 000	122 000	3 250	1 850	19,2	1,76	NJ236-E-XL-M1	HJ236-E
	320	52	730 000	830 000	122 000	3 250	1 850	17,3	–	NUP236-E-XL-M1	–
	320	86	1 180 000	1 490 000	225 000	3 200	1 380	31,1	–	NJ2236-E-XL-M1	–
	320	86	1 180 000	1 490 000	225 000	3 200	1 380	31,1	1,87	NJ2236-E-XL-M1	HJ2236-E
	320	86	1 180 000	1 490 000	223 000	3 200	1 380	31,6	–	NUP2236-E-XL-M1	–
	380	75	1 040 000	1 320 000	143 000	2 650	1 500	44,6	–	NJ336-E-TB-M1	–
	380	75	1 040 000	1 320 000	143 000	2 650	1 500	44,6	3,77	NJ336-E-TB-M1	HJ336-E
	380	126	1 680 000	2 330 000	255 000	2 600	1 120	72,9	–	NJ2336-E-XL-M1	–
190	340	55	680 000	930 000	111 000	3 050	1 720	23,2	–	NJ238-E-M1	–
	340	55	680 000	930 000	111 000	3 050	1 720	23,2	2,17	NJ238-E-M1	HJ238-E
	340	55	680 000	930 000	111 000	3 050	1 720	23,5	–	NUP238-E-M1	–
	340	92	1 090 000	1 650 000	201 000	3 000	1 290	37,7	–	NJ2238-E-M1	–
	340	92	1 090 000	1 650 000	201 000	3 000	1 290	37,7	2,31	NJ2238-E-M1	HJ2238-E
	400	132	1 890 000	2 650 000	285 000	2 440	1 010	84,4	–	NJ2338-EX-TB-M1	–
	400	132	1 890 000	2 650 000	285 000	2 440	1 010	84,4	4,8	NJ2338-EX-TB-M1	HJ2338-E
200	360	58	750 000	1 040 000	122 000	2 900	1 600	27,5	–	NJ240-E-M1	–
	360	58	750 000	1 040 000	122 000	2 900	1 600	27,5	2,62	NJ240-E-M1	HJ240-E
	360	58	750 000	1 040 000	121 000	2 900	1 600	28	–	NUP240-E-M1	–
	360	98	1 220 000	1 880 000	225 000	2 850	1 180	45,3	–	NJ2240-E-M1	–
	360	98	1 220 000	1 880 000	225 000	2 850	1 180	45,3	2,78	NJ2240-E-M1	HJ2240-E
	420	80	1 180 000	1 520 000	162 000	2 410	1 320	58,1	–	NJ340-E-TB-M1	–
	420	80	1 180 000	1 520 000	162 000	2 410	1 320	58,1	4,94	NJ340-E-TB-M1	HJ340-E
	420	138	2 040 000	2 900 000	310 000	2 330	940	97,2	–	NJ2340-EX-TB-M1	–
	420	138	2 040 000	2 900 000	310 000	2 330	940	97,2	5,28	NJ2340-EX-TB-M1	HJ2340-E

medias ► <https://www.schaeffler.de/std/1DB4>

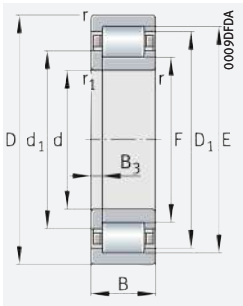

NUP
Locating bearing

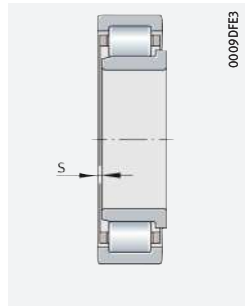

Axial displacement "s"
for NJ

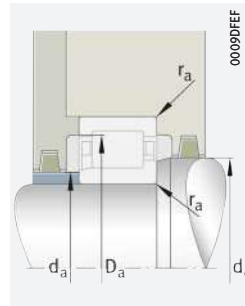

Mounting dimensions
for NJ

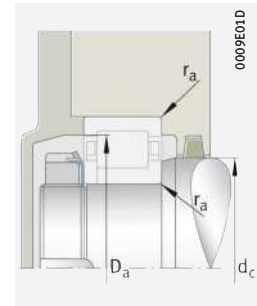

Mounting dimensions
for NUP

Dimensions

Mounting dimensions

d	r	r ₁		s	E	F	D ₁	d ₁	B ₁	B ₂	B ₃	d _a		d _c	D _a	r _a	
		min.	min.									min. ¹⁾	max.			min.	max. ¹⁾
180	4	4	4	4,7	289	217	278,6	230,2	-	-	-	197	214	233	303	3	3
	4	4	-	-	289	217	278,6	230,2	12	20	-	197	-	233	303	3	3
	4	4	-	-	289	217	278,6	230,2	-	-	8	197	-	233	303	3	3
	4	4	-	7,2	291	215	280	229	-	-	-	197	214	233	303	3	3
	4	4	-	-	291	215	280	229	12	24	-	197	-	233	303	3	3
	4	4	-	-	291	215	280	229	-	-	12	197	-	233	303	3	3
	4	4	6,1	-	231	314,2	251,8	-	-	-	-	197	228	254	363	3	3
	4	4	-	-	231	314,2	251,8	17	28,5	-	-	197	-	254	363	3	3
	4	4	10,5	-	227	316,6	249,4	-	-	-	-	197	225	250,6	363	3	3
4	4	-	-	227	316,6	249,4	17	35	-	-	197	-	250,6	363	3	3	
190	4	4	4	4,7	306	230	295	244	-	-	-	207	227	247	323	3	3
	4	4	-	-	306	230	295	244	13	21,5	-	207	-	247	323	3	3
	4	4	-	-	306	230	295	244	-	-	8,5	207	-	247	323	3	3
	4	4	8	-	308	228	296,4	242,7	-	-	-	207	227	247	323	3	3
	4	4	-	-	308	228	296,4	242,7	13	26,5	-	207	-	247	323	3	3
	5	5	11	-	240	336	264	-	-	-	-	210	237,8	265,3	380	4	4
	5	5	-	-	240	336	264	18	36,5	-	-	210	-	265,3	380	4	4
200	4	4	4	4,8	323	243	311,5	257,6	-	-	-	217	240	261	343	3	3
	4	4	-	-	323	243	311,5	257,6	14	23	-	217	-	261	343	3	3
	4	4	-	-	323	243	311,5	257,6	-	-	9	217	-	261	343	3	3
	4	4	8,2	-	325	241	312,9	256,3	-	-	-	217	240	261	343	3	3
	4	4	-	-	325	241	312,9	256,3	14	28	-	217	-	261	343	3	3
	5	5	6,3	-	258	347,6	280,4	-	-	-	-	220	255	282	400	4	4
	5	5	-	-	258	347,6	280,4	18	30	-	-	220	-	282	400	4	4
	5	5	11,3	-	253	352,2	277,8	-	-	-	-	220	250,7	279	400	4	4
	5	5	-	-	253	352,2	277,8	18	37	-	-	220	-	279	400	4	4

¹⁾ Under axial load, observe the dimensions D₁ and d₁.





Cylindrical roller bearings with cage

Semi-locating bearings, locating bearings

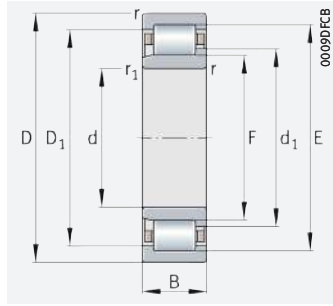

NJ
Semi-locating bearing

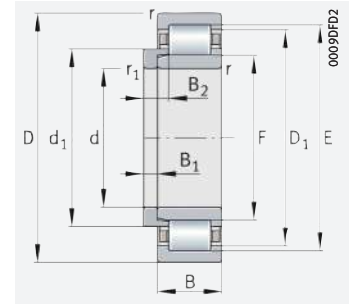

NJ and HJ
Locating bearings

d = 220 – 280 mm

Main dimensions			Basic load ratings		Fatigue limit load	Limiting speed	Speed rating	Mass m		Designation	
d	D	B	dyn. C_r	stat. C_{0r}	C_{ur}	n_G	n_{dr}	Bearing	L-section ring	Bearing	L-section ring
			N	N	N	min^{-1}	min^{-1}	$\approx \text{kg}$	$\approx \text{kg}$		
220	400	65	950 000	1 330 000	150 000	2 600	1 380	38,7	–	NJ244-E-M1	–
	400	65	950 000	1 330 000	150 000	2 600	1 380	38,7	3,55	NJ244-E-M1	HJ244-E
	400	65	950 000	1 330 000	150 000	2 600	1 380	39,3	–	NUP244-E-M1	–
	400	108	1 630 000	2 370 000	250 000	2 440	1 000	63,4	–	NUP2244-EX-TB-M1	–
	460	145	2 350 000	3 350 000	345 000	2 110	830	124	–	NUP2344-EX-TB-M1	–
240	440	72	1 140 000	1 610 000	171 000	2 320	1 220	52,5	–	NJ248-E-TB-M1	–
	440	72	1 140 000	1 610 000	171 000	2 320	1 220	52,5	4,6	NJ248-E-TB-M1	HJ248-E
	500	95	1 720 000	2 280 000	234 000	1 980	1 000	97	–	NJ348-E-TB-M1	–
	500	95	1 720 000	2 280 000	234 000	1 980	1 000	97	8,3	NJ348-E-TB-M1	HJ348-E
260	480	80	1 350 000	1 890 000	192 000	2 100	1 110	69,4	–	NJ252-E-TB-M1	–
	480	80	1 350 000	1 890 000	192 000	2 100	1 110	69,4	5,92	NJ252-E-TB-M1	HJ252-E
280	580	108	2 180 000	3 050 000	290 000	1 700	790	149	–	NJ356-E-TB-M1	–
	580	108	2 180 000	3 050 000	290 000	1 700	790	149	13,7	NJ356-E-TB-M1	HJ356-E

medias ► <https://www.schaeffler.de/std/1DB5>

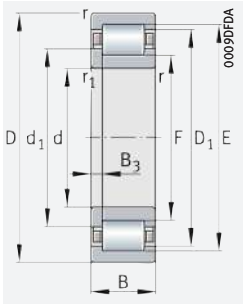

NUP
Locating bearing

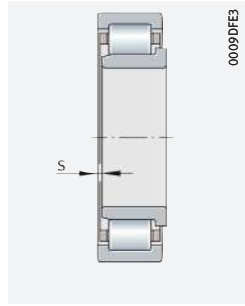

Axial displacement "s"
for NJ

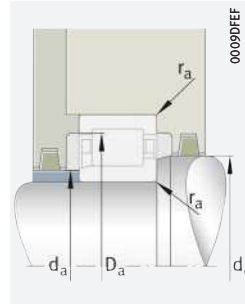

Mounting dimensions
for NJ

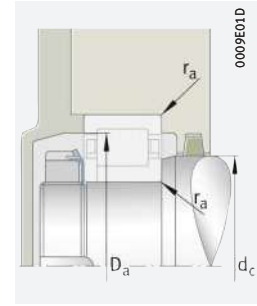

Mounting dimensions
for NUP

Dimensions

Mounting dimensions

d	r	r ₁ min.	s	E	F	D ₁ ≈	d ₁ ≈	B ₁	B ₂	B ₃	d _a		d _c	D _a	r _a
											min. ¹⁾	max.			
220	4	4	5,5	358	268	344,9	285,2	-	-	-	237	265	288	383	3
	4	4	-	358	268	344,9	285,2	15	25	-	237	-	288	383	3
	4	4	-	358	268	344,9	285,2	-	-	10	237	-	288	383	3
	4	4	-	367	259	345,4	280,6	-	-	14	237	-	282,3	383	3
	5	5	-	413	277	385,8	304,2	-	-	20	240	-	305,1	440	4
240	4	4	6	-	293	373	313	-	-	-	257	290	315	423	3
	4	4	-	-	293	373	313	16	27	-	257	-	315	423	3
	5	5	7,4	-	306	414,8	333,2	-	-	-	260	303	335	480	4
	5	5	-	-	306	414,8	333,2	22	35,5	-	260	-	335	480	4
260	5	5	6,2	-	317	406,6	339,7	-	-	-	280	314	341	460	4
	5	5	-	-	317	406,6	339,7	18	30	-	280	-	341	460	4
280	6	6	8,7	-	362	482	392	-	-	-	306	359	393,4	554	5
	6	6	-	-	362	482	392	26	42,5	-	306	-	393,4	554	5

¹⁾ Under axial load, observe the dimensions D₁ and d₁.



2 Cylindrical roller bearings with disc cage or with spacers



Cylindrical roller bearings with disc cage/with spacers are suitable where:

- bearing arrangements are subjected to very high radial loads and higher speeds occur ▶480|2.2, ▶484|2.6
- high dynamic inertia forces are present
- not only high radial forces but also axial loads from one direction must be supported by the bearing position (semi-locating bearing function) ▶480|2.2
- high shock loads occur
- thermally stable conditions are required in the bearing even at higher speeds
- the cages are subjected to high dynamic inertia forces; e.g. in vibratory machinery
- axial displacements of the shaft relative to the housing must be compensated without constraint in the bearing
- the bearings should be separable for easier mounting; in vibratory machinery, for example, the bearing ring with circumferential load as well as the ring with point load should have a tight fit ▶478|2.1, ▶492|2.17.

For an overview of other product-specific features, see the Matrix for bearing preselection ▶410.

1
Cylindrical roller bearing with full complement bearing/standard cage/disc cage, comparison of speed and load carrying capacity

n_G = limiting speed

C_r = basic dynamic load rating

SL1923 = full complement cylindrical roller bearing

NJ23 = cylindrical roller bearing with standard cage

LSL1923 = cylindrical roller bearing with disc cage

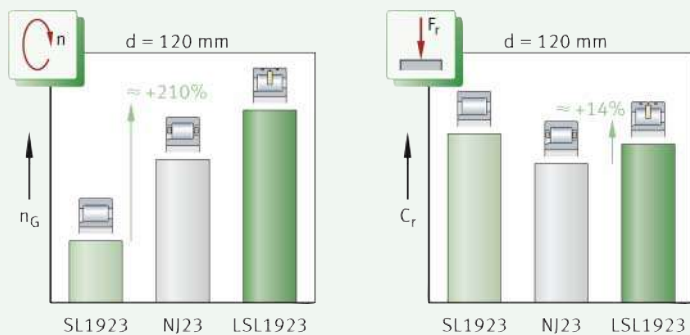

2.1 Bearing design

Design variants

These cylindrical roller bearings are available as:

- type LSL1923 (bearing with disc cage) ▶479| 2
- type ZSL1923 (bearing with spacers) ▶479| 3
- special design for vibratory machinery ▶480
- X-life bearings ▶480.

LSL1923 and ZSL1923 correspond to dimension series 23

Basic design – standard range

Cylindrical roller bearings with disc cage or with spacers are part of the group of radial roller bearings and correspond to dimension series 23. These single row bearings comprise radially split outer rings, removable inner rings, disc cages or spacers and cylindrical rollers. The rollers have profiled ends, i.e. they have a slight lateral curvature towards the ends. This modified line contact between the rolling elements and raceways prevents damaging edge stresses >413|☐2. For mounting of the bearings, the inner ring can be removed.

Bearings with semi-locating bearing function

Series LSL1923 – bearings with disc cage

Cylindrical roller bearings LSL1923 have two rigid ribs on the outer ring and one rigid rib on the inner ring. An externally-guided flat brass disc cage prevents the rolling elements from coming into contact with each other during rolling >479|☐2 and >486|2.9. The disc cage has pockets in which the rolling elements run. The rollers are guided between the ribs on the outer ring. The outer ring is axially split and held together by fasteners. Due to their design configuration, the bearings permit axial displacements of the shaft relative to the housing in one direction. In the opposite direction, they act as locating bearings. The maximum axial displacement *s* is given in the product tables.

☐2
Cylindrical roller bearing with disc cage

F_r = radial load

F_a = axial load

① Brass disc cage

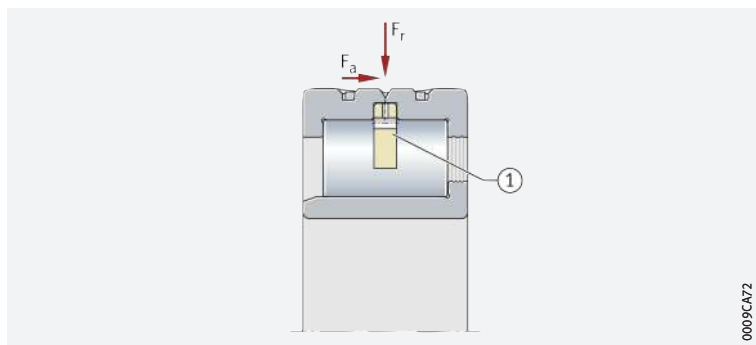

0009CA72

Bearings with semi-locating bearing function

Series ZSL1923 – bearings with spacers

In the case of cylindrical roller bearings ZSL1923, plastic spacers prevent the rollers from coming into contact with each other during rolling >479|☐3 and >486|2.9. The spacers are guided axially between the ribs on the outer ring. They are designed such that the rolling element set is self-retaining, so the outer ring with the rolling element set and the inner ring can be mounted separately from each other. Due to their design configuration, the bearings permit axial displacements of the shaft relative to the housing in one direction. In the opposite direction, they act as locating bearings. The maximum axial displacement *s* is given in the product tables.

☐3
Cylindrical roller bearing with spacers

F_r = radial load

F_a = axial load

① Plastic spacers

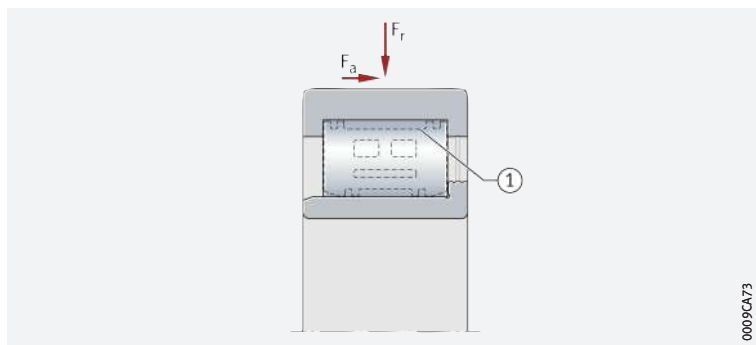

0009CA73

Special design of bearings LSL and ZSL for vibratory machinery



In addition to high basic dynamic load ratings C_r (and thus long rating life values), bearings for vibratory machinery must also be able to compensate or support considerable shaft tilting due to load or misalignment. The cylindrical roller bearings LSL and ZSL are therefore also available by agreement in the BIR design \blacktriangleright 488 |  4. In these bearings, the inner ring raceway is ground slightly spherical.

X-life premium quality



Many sizes of the bearings are also available as X-life bearings. These bearings exhibit considerably higher performance than comparable standard cylindrical roller bearings. This is achieved, for example, through the modified internal construction, the optimised contact geometry between the rollers and raceways, better surface quality and the optimised roller guidance and lubricant film formation.

 *Increased customer benefits due to X-life*

These technical enhancements offer a range of advantages, such as:

- a more favourable load distribution in the bearing and thus a higher dynamic load carrying capacity of the bearings
- a higher fatigue limit load
- lower heat generation in the bearing
- lower lubricant consumption and therefore longer maintenance intervals if relubrication is carried out
- a measurably longer operating life of the bearings
- high operational security
- compact, environmentally-friendly bearing arrangements.

 *Interchangeable with comparable standard bearings*

Since X-life cylindrical roller bearings have the same dimensions as the corresponding standard bearings, the latter can be replaced without any problems by the higher-performance X-life bearings. The major advantages of X-life can therefore also be used for existing bearing arrangements with standard bearings.

 *Lower operating costs, higher machine availability*

In conclusion, these advantages improve the overall cost-efficiency of the bearing position significantly and thus bring about a sustainable increase in the efficiency of the machine and equipment.

 *Suffix XL*

X-life cylindrical roller bearings include the suffix XL in the designation \blacktriangleright 488 | 2.12 and \blacktriangleright 494 | .



X-life indicates a high product performance density and thus a particularly significant benefit to the customer. Further information on X-life \blacktriangleright 10.



2.2

Load carrying capacity

 *Designed for high radial loads*

Cylindrical roller bearings LSL and ZSL are used as semi-locating bearings. These bearings can support not only high radial forces but also axial loads in one direction; i.e. they can guide the shaft axially in one direction. Furthermore, they can withstand high shock loads, vibrations and accelerations.

 *Higher basic dynamic load ratings lead to an increase in basic rating life*

Due to the internal construction, the bearings can accommodate more rolling elements than conventional cylindrical roller bearings. As a result, there is a significant increase in the basic dynamic and static load rating and thus the basic rating life compared with conventional cylindrical roller bearings. \blacktriangleright 481 |  4 shows a comparison of the basic dynamic load rating C_r between a cylindrical roller bearing NJ2324 with a conventional cage, a bearing with a disc cage and a bearing with spacers. The advantage in basic dynamic load rating of approx. 14% gives an increase in the basic rating life of approx. 55% \blacktriangleright 481 |  5.

4

Comparison of basic dynamic load ratings – conventional cylindrical roller bearing NJ2324 with LSL192324 and ZSL192324

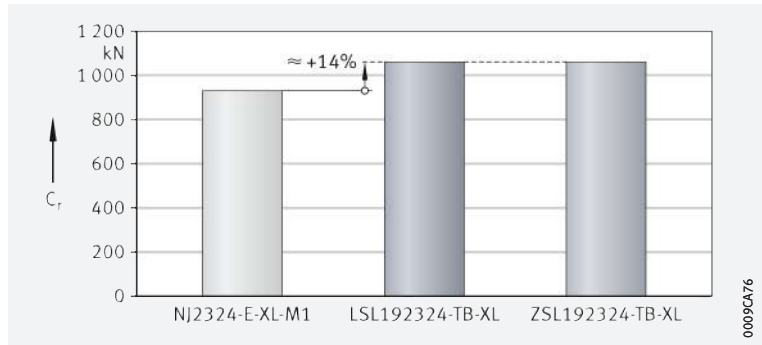

5

Comparison of basic percentage rating life – conventional cylindrical roller bearing NJ2324 with LSL192324 and ZSL192324

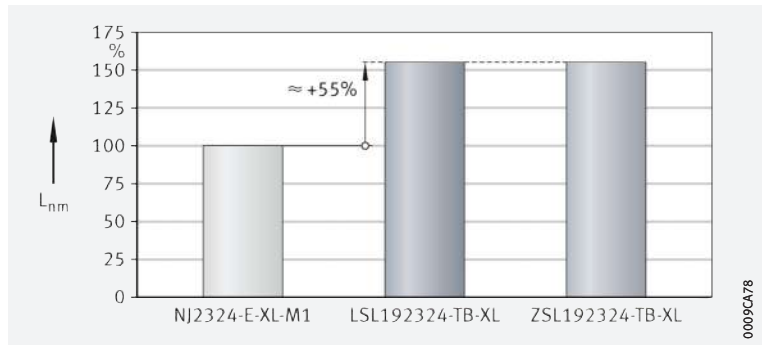

Higher axial load carrying capacity of bearings with toroidal crowned roller end face

Neither wear nor fatigue occurs on the rib contact running and roller end faces

In the case of cylindrical roller bearings with toroidal crowned rollers (TB design), the axial load carrying capacity has been significantly improved with the aid of new calculation and manufacturing methods. A special curvature of the roller end faces facilitates optimum contact conditions between the rollers and ribs >481|6. As a result, the axial contact pressures on the rib are significantly minimised and a lubricant film capable of supporting higher loads is formed. Under standard operating conditions, this completely eliminates wear and fatigue at the rib contact running and roller end faces. In addition, the frictional torque is reduced by up to 50%. The bearing temperature during operation is therefore significantly lower. Bearings of the toroidal crowned design are available for a bore diameter of, or larger than, $d = 90 \text{ mm}$ >494|8.

6

Contact geometry of roller end face/rib face – modified roller end faces

- 1 Cylindrical roller with inner ring
- 2 Detail (representation not to scale)
- 3 End of roller
- 4 Rib

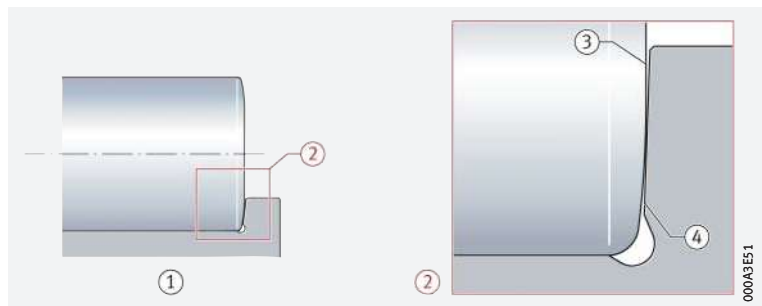

Load ratio F_a/F_r

Ratio $F_a/F_r \leq 0,4$ or $0,6$

The bearings can support axial loads on one side by means of the ribs on the inner and outer ring >482|7. In order to ensure problem-free running (tilting of the rollers is prevented), they must always be subjected to radial load at the same time as axial load. The ratio F_a/F_r must not exceed the value 0,4. For bearings with toroidal crowned roller ends (TB design), values up to 0,6 are permissible.



Continuous axial loading without simultaneous radial loading is not permissible.

Permissible axial load

Influencing factors on the axial load carrying capacity

Axial loads are supported by the bearing ribs and the roller end faces ▶482|☐7 and ▶492|☐13. The axial load carrying capacity of the bearing is therefore essentially dependent on:

- the size of the sliding surfaces between the ribs and the end faces of the rolling elements
- the sliding velocity at the ribs
- the lubrication of the contact surfaces
- tilting of the bearing
- friction.

☐7
Force flow under axial load – semi-locating bearing LSL1923

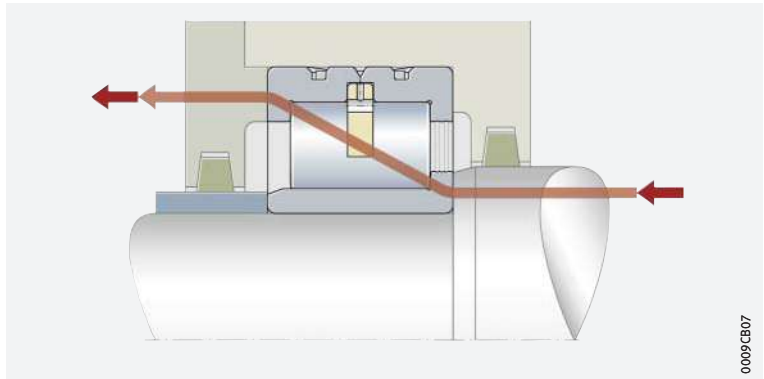

Calculation of permissible axial load – cylindrical rollers with conventional roller ends

Bearings with standard roller ends

The permissible axial load $F_{a\ per}$ can be calculated from the hydrodynamic load carrying capacity of the contact ▶482|f1.

f1
Permissible axial load – bearings of standard design

$$F_{a\ per} = k_S \cdot k_B \cdot d_M^{1,54} \cdot n^{-0,6} \leq F_{a\ max}$$

Legend

$F_{a\ per}$	N	Permissible continuous axial load. In order to prevent unacceptably high temperatures in the bearing, $F_{a\ per}$ must not be exceeded
$F_{a\ max}$	N	Maximum continuous axial load in relation to rib fracture. In order to prevent unacceptably high pressures at the contact surfaces, $F_{a\ max}$ must not be exceeded
k_S	–	Factor as a function of lubrication method ▶482 ☐1. The factor takes into consideration the lubrication method used for the bearing. The better the lubrication and, in particular, the heat dissipation, the higher the permissible axial load
k_B	–	Factor as a function of the bearing series, $k_B = 28$
d_M	mm	Mean bearing diameter $d_M = (D + d)/2$ ▶494 ☐☐
n	min ⁻¹	Operating speed.

☐1
Factor k_S

Lubrication method	Factor k_S	
	from	up to
Minimal heat dissipation, drip feed oil lubrication, oil mist lubrication, low operating viscosity ($\nu < 0,5 \cdot \nu_1$)	7,5	10
Poor heat dissipation, oil sump lubrication, oil spray lubrication, low oil flow	10	15
Good heat dissipation, recirculating oil lubrication (pressurised oil lubrication)	12	18
Very good heat dissipation, recirculating oil lubrication with oil cooling, high operating viscosity ($\nu > 2 \cdot \nu_1$)	16	24

! The precondition for these k_S values is an operating viscosity of the lubricant of at least the reference viscosity ν_1 in accordance with DIN ISO 281:2010.



Doped lubricating oils should be used, such as CLP (DIN 51517) and HLP (DIN 51524) of ISO VG grades 32 to 460, as well as ATF oils (DIN 51502) and transmission oils (DIN 51512) of SAE viscosity grades 75W to 140W.

Calculation of permissible axial load – cylindrical rollers with toroidal roller ends

Higher axial loads possible For bearings with toroidal roller ends, the permissible axial loads are 50% higher **► 483 | f1 2.**

f1 2
Permissible axial load – bearings of TB design

$$F_{a\text{ per}} = 1,5 \cdot k_S \cdot k_B \cdot d_M^{1,54} \cdot n^{-0,6} \leq F_{a\text{ max}}$$

Calculation of maximum permissible axial load

! For bearings with rollers of the standard or TB design, the maximum permissible axial load $F_{a\text{ max}}$ **► 483 | f1 3** is calculated from the rib strength and the security against wear. This must not be exceeded, even if $F_{a\text{ per}}$ gives higher values **► 483 | f1 4.**

f1 3
Maximum axial load – bearings of standard and TB design

$$F_{a\text{ max}} = 0,075 \cdot k_B \cdot d_M^{2,1}$$

f1 4
Permissible axial load

$$F_{a\text{ per}} \leq F_{a\text{ max}}$$

Axial load under shaft deflection

Permissible axial load under shaft deflection of up to 2' Under considerable shaft deflection, the shaft shoulder presses against the inner ring rib. In combination with the active axial load, this can lead to high alternating loading of the inner ring ribs. Under a shaft deflection of up to 2', the permissible axial load can be estimated **► 483 | f1 5.**



If more severe tilting is present, a separate strength analysis is required. In this case, please contact Schaeffler.

f1 5
Axial load under misalignment

$$F_{as} = 20 \cdot d_M^{1,42}$$

Legend

F_{as} | N | Permissible axial load under misalignment.

2.3 Compensation of angular misalignments

Angular deviations are misalignments between the inner and outer ring

The permissible misalignment between the inner ring and outer ring is influenced by the internal bearing construction, the operating clearance, the forces acting on the bearings etc. Due to these complex relationships, it is not possible to give generally valid absolute values here.

However, misalignments (angular deviations) between the inner ring and outer ring will generally always have an effect on the running noise and the operating life of the bearings.

Permissible tilting

The permissible guide value at which, based on experience, there is no significant reduction in operating life is 3'.

 **Scope of value**

The value applies to:

- bearing arrangements with static misalignment (consistent position of the shaft and housing axis)
- bearings that are not required to perform an axial guidance function
- bearings subjected to small loads (with $C_{0r}/P \geq 5$).



Checking by means of the calculation program BEARINX is recommended in all cases. If there is any uncertainty regarding possible misalignment, please consult Schaeffler.

2.4 Lubrication

 **Oil or grease lubrication is possible**

The cylindrical roller bearings are not greased. They must be lubricated with oil or grease.

 **Pay attention to the compatibility of the lubricant with plastic**

When using bearings with plastic spacers, compatibility between the lubricant and the cage material must be ensured if synthetic oils, lubricating greases with a synthetic oil base or lubricants containing a high proportion of EP additives are used.



If there is any uncertainty regarding the suitability of the selected lubricant for the application, please consult Schaeffler or the lubricant manufacturer.

 **Observe oil change intervals**

Aged oil and additives in the oil can impair the operating life of plastics at high temperatures. As a result, stipulated oil change intervals must be strictly observed.

2.5 Sealing

 **Provide seals in the adjacent construction**

The bearings are not sealed, i.e. sealing of the bearing position must be carried out in the adjacent construction. This must reliably prevent:

- moisture and contaminants from entering the bearing
- the egress of lubricant from the bearing.

2.6 Speeds

 **Limiting speeds and reference speeds in the product tables**

The product tables give two speeds for most bearings  **494**:

- the kinematic limiting speed n_G
- the thermal speed rating $n_{\vartheta r}$.

Limiting speeds

The limiting speed n_G is the kinematically permissible speed of the bearing. Even under favourable mounting and operating conditions, this value should not be exceeded without prior consultation with Schaeffler **64**.

Reference speeds **$n_{\vartheta r}$ is used to calculate n_{ϑ}**

The thermal speed rating $n_{\vartheta r}$ is not an application-oriented speed limit, but is a calculated ancillary value for determining the thermally safe operating speed n_{ϑ} **64**.

2.7 Noise

The Schaeffler Noise Index (SGI) has been developed as a new feature for comparing the noise level of different bearing types and series. As a result, a noise evaluation of rolling bearings can now be carried out for the first time.

Schaeffler Noise Index

The SGI value is based on the maximum permissible noise level of a bearing in accordance with internal standards, which is calculated on the basis of ISO 15242. In order that different bearing types and series can be compared, the SGI value is plotted against the basic static load rating C_0 .

This permits direct comparisons between bearings with the same load carrying capacity. The upper limit value is given in each of the diagrams. This means that the average noise level of the bearings is lower than illustrated in the diagram.



The Schaeffler Noise Index is an additional performance characteristic in the selection of bearings for noise-sensitive applications. The specific suitability of a bearing for an application in terms of installation space, load carrying capacity or speed limit for example, must be checked independently of this.



The Noise Index is currently available for the main series. Additional series will be updated and introduced in subsequent publications.

Further information:

■ **medias** ► <https://medias.schaeffler.com>.



8 Schaeffler Noise Index for cylindrical roller bearings with spacers

SGI = Schaeffler Noise Index
 C_0 = basic static load rating

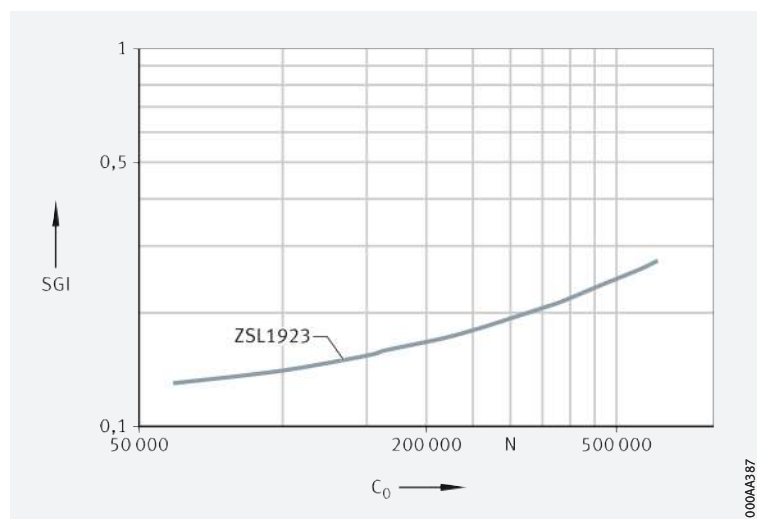

2.8 Temperature range

Limiting values

- The operating temperature of the bearings is limited by:
- the dimensional stability of the bearing rings and cylindrical rollers
 - the cage (disc cage or spacers)
 - the lubricant.

Possible operating temperatures of bearings ▶486|2.

Permissible temperature ranges

Operating temperature	Cylindrical roller bearings with disc cage or with spacers
	-30 °C to +120 °C



In the event of anticipated temperatures which lie outside the stated values, please contact Schaeffler.

2.9 Cages

Bearings with a disc cage or spacers are suitable for applications with high dynamic inertia forces

In addition to the actual task of a bearing cage, which is to hold rolling elements apart from each other, a cage designed for vibrations (e.g. for use in vibratory machinery) must be able to support, on a fatigue-resistant basis, principally the inertia forces that act on the cage due to its own mass, as well as the inertia forces of the rolling elements that act directly on the cage pockets. Since these applications also call for very high basic load ratings, conventional cages can only support this requirement under very limited conditions. As a result, bearings with a brass disc cage or plastic spacers have been developed, which constitute a transition from full complement bearings to conventional cage bearings.

Rolling elements are held by the cage

Disc cage

This cage is designed as a flat disc ▶486|9. Facing towards the inside diameter are rolling element pockets that support the rolling elements. The cage inside diameter is extended downwards to below the pitch circle line. This gives retention of the rolling elements, i.e. the inner ring can be mounted separately from the rest of the bearing. Facing the outside diameter, the disc cage is seated concentrically between the ribs in a slot in the outer ring.

Rollers and solid brass disc cage



0009CA60

Lower bearing frictional torque due to the geometry of the spacers

Spacers

The plastic spacers were developed specially for the series ZSL1923 ▶487|10. They are designed such that the rolling element set is self-retaining, i.e. the bearing and inner ring can be mounted separately from each other.

10
Rollers and plastic spacers



2.10 Internal clearance

Radial internal clearance

The standard is CN

As standard, cylindrical roller bearings with disc cage or with spacers have the radial internal clearance CN (normal) ▶487|3. CN is not stated in the designation.



When used in vibratory machinery, both bearing rings have a tight fit. As a result, and due to the temperature differential between the inner ring and outer ring, the internal clearance C4 is generally necessary. As standard, bearings for vibratory machinery therefore have this internal clearance group.



Certain sizes are also available by agreement with the larger internal clearance C3, C4 and C5 ▶487|3.



The values for radial internal clearance correspond to DIN 6204:2004 (ISO 5753-1:2009) ▶487|3. They are valid for bearings which are free from load and measurement forces (without elastic deformation).

3
Radial internal clearance of cylindrical roller bearings with disc cage or with spacers

Nominal bore diameter d		Radial internal clearance							
		CN (Group N)		C3 (Group 3)		C4 (Group 4)		C5 (Group 5)	
mm		μm		μm		μm		μm	
over	incl.	min.	max.	min.	max.	min.	max.	min.	max.
–	24	20	45	35	60	50	75	65	90
24	30	20	45	35	60	50	75	70	95
30	40	25	50	45	70	60	85	80	105
40	50	30	60	50	80	70	100	95	125
50	65	40	70	60	90	80	110	110	140
65	80	40	75	65	100	90	125	130	165
80	100	50	85	75	110	105	140	155	190
100	120	50	90	85	125	125	165	180	200
120	140	60	105	100	145	145	190	200	245
140	160	70	120	115	165	165	215	225	275
160	180	75	125	120	170	170	220	250	300
180	200	90	145	140	195	195	250	275	330
200	225	105	165	160	220	220	280	305	365
225	250	110	175	170	235	235	300	330	395
250	280	125	195	190	260	260	330	370	440
280	315	130	205	200	275	275	350	410	485

2.11 Dimensions, tolerances

Dimension standards



The main dimensions of cylindrical roller bearings correspond to ISO 15:2017 (DIN 616:2000 and DIN 5412-1:2005).

Chamfer dimensions



The limiting dimensions for chamfer dimensions correspond to DIN 620-6:2004. Overview and limiting values ▶ 135 | 7.11. Nominal value of chamfer dimension ▶ 494 | 8.

Tolerances



The dimensional and running tolerances correspond to the tolerance class Normal in accordance with ISO 492:2014. Tolerance values in accordance with ISO 492 ▶ 122 | 8.

2.12 Suffixes

For a description of the suffixes used in this chapter ▶ 488 | 4 and **medias** interchange ▶ <https://www.schaeffler.de/std/1D52>.

4 Suffixes and corresponding descriptions

Suffix	Description of suffix	
BIR	Inner ring raceway ground slightly spherical	Available by agreement
BR	Black oxide coated	
C3	Radial internal clearance C3 (larger than normal)	
C4	Radial internal clearance C4 (larger than C3)	
C5	Radial internal clearance C5 (larger than C4)	
TB	Bearing with increased axial load carrying capacity	Standard dependent on bearing size
XL	X-life bearing	

2.13 Structure of bearing designation

Examples of composition of bearing designation

The designation of bearings follows a set model. Examples ▶ 488 | 11 and ▶ 488 | 12. The composition of designations is subject to DIN 623-1 ▶ 102 | 10.

11 Cylindrical roller bearing with disc cage: designation structure

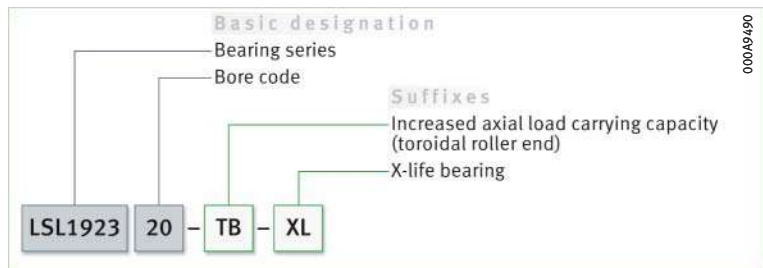

12 Cylindrical roller bearing with spacers, internal clearance C3: designation structure

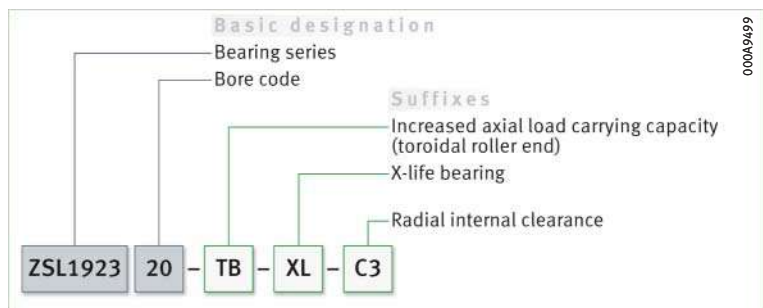

2.14 Dimensioning

☞ $P = F_r$ under purely radial load of constant magnitude and direction

Equivalent dynamic bearing load

The basic rating life equation $L = (C_r/P)^P$ used in the dimensioning of bearings under dynamic load assumes a load of constant magnitude and direction. In radial bearings, this is a purely radial load F_r . If this condition is met, the bearing load F_r is used in the rating life equation for P ($P = F_r$).

$$\text{☞ } P = F_r$$

Cylindrical roller bearings with non-locating bearing function

Non-locating bearings can only support radial loads. For these bearings ▶ 489 | § 6.

§ 6

Equivalent dynamic load

$$P = F_r$$

☞ P is a substitute force for combined load and various load cases

Cylindrical roller bearings with semi-locating or locating bearing function

If the condition described above is not met, i.e. if, in addition to the radial force F_r , there is also an axial force F_a , a constant radial force must first be determined for the rating life calculation that (in relation to the rating life) represents an equivalent load. This force is known as the equivalent dynamic bearing load P .

☞ $F_a/F_r \leq e$ or $F_a/F_r > e$

The calculation of P is dependent on the load ratio F_a/F_r and the calculation factors e and Y ▶ 489 | § 7 and ▶ 489 | § 8.

§ 7

Equivalent dynamic load

$$\frac{F_a}{F_r} \leq e \Rightarrow P = F_r$$

§ 8

Equivalent dynamic load

$$\frac{F_a}{F_r} > e \Rightarrow P = 0,92 \cdot F_r + Y \cdot F_a$$

Legend

P	N	Equivalent dynamic bearing load
F_r	N	Radial load
F_a	N	Axial load
e	-	Factor, $e = 0,3$
Y	-	Factor, $Y = 0,4$.

Equivalent static bearing load

☞ $P_0 = F_{0r}$ For cylindrical roller bearings subjected to static load ▶ 489 | § 9.

§ 9

Equivalent static load

$$P_0 = F_{0r}$$

Legend

P_0	N	Equivalent static bearing load
F_{0r}	N	Largest radial load present (maximum load).

Static load safety factor

☞ $S_0 = C_0/P_0$ In addition to the basic rating life $L (L_{10h})$, it is also always necessary to check the static load safety factor S_0 ▶ 489 | § 10.

§ 10

Static load safety factor

$$S_0 = \frac{C_0}{P_0}$$

Legend

S_0	-	Static load safety factor
C_0	N	Basic static load rating
P_0	N	Equivalent static bearing load.



2.15 Minimum load

In order to prevent damage due to slippage, a minimum radial load of $P > C_{Or}/60$ is necessary during continuous operation

In order that no slippage occurs between the contact partners, the cylindrical roller bearings must be constantly subjected to a sufficiently high radial load. For continuous operation, experience shows that a minimum radial load of the order of $P > C_{Or}/60$ is thus necessary. In most cases, however, the radial load is already higher than the requisite minimum load due to the weight of the supported parts and the external forces.



If the minimum radial load is lower than indicated above, please consult Schaeffler.

2.16 Design of bearing arrangements

Support bearing rings over their entire circumference and width

In order to allow full utilisation of the load carrying capacity of the bearings and achieve the requisite rating life, the bearing rings must be rigidly and uniformly supported by means of contact surfaces over their entire circumference and over the entire width of the raceway. Support can be provided by means of a cylindrical seating surface. The seating and contact surfaces should not be interrupted by grooves, holes or other recesses. The accuracy of mating parts must meet specific requirements [▶ 491](#) | [5](#) to [▶ 491](#) | [7](#).

For secure radial location, tight fits are necessary

Radial location

In addition to supporting the rings adequately, the bearings must also be securely located in a radial direction, to prevent creep of the bearing rings on the mating parts under load. This is generally achieved by means of tight fits between the bearing rings and the mating parts. If the rings are not secured adequately or correctly, this can cause severe damage to the bearings and adjacent machine parts. Influencing factors, such as the conditions of rotation, magnitude of the load, internal clearance, temperature conditions, design of the mating parts and the mounting and dismounting options must be taken into consideration in the selection of fits.



If shock type loads occur, tight fits (transition fit or interference fit) are required to prevent the rings from coming loose at any point. Clearance, transition or interference fits [▶ 150](#) | [6](#) and [▶ 158](#) | [7](#).



The following information provided in Technical principles must be taken into consideration in the design of bearing arrangements:

- conditions of rotation [▶ 145](#)
- tolerance classes for cylindrical shaft seats (radial bearings) [▶ 147](#) | [2](#)
- shaft fits [▶ 150](#) | [6](#)
- tolerance classes for bearing seats in housings (radial bearings) [▶ 148](#) | [4](#)
- housing fits [▶ 158](#) | [7](#).

The bearings must also be securely located in an axial direction

Axial location

As a tight fit alone is not normally sufficient to also locate the bearing rings securely on the shaft and in the housing bore in an axial direction, this must usually be achieved by means of an additional axial location or retention method. The axial location of the bearing rings must be matched to the type of bearing arrangement. Shaft and housing shoulders, housing covers, nuts, spacer rings, retaining rings, adapter and withdrawal sleeves etc., are fundamentally suitable; example [▶ 492](#) | [13](#).

Dimensional, geometrical and running accuracy of cylindrical bearing seats

A minimum of IT6 should be provided for the shaft seat and a minimum of IT7 for the housing seat

The accuracy of the cylindrical bearing seat on the shaft and in the housing should correspond to the accuracy of the bearing used. For cylindrical roller bearings with the tolerance class Normal, the shaft seat should correspond to a minimum of standard tolerance grade IT6 and the housing seat to a minimum of IT7. Guide values for the geometrical and positional tolerances of the bearing seating surfaces ▶491| 5, tolerances t_1 to t_3 in accordance with ▶168| 11. Numerical values for IT grades ▶491| 6.

5
Guide values for the geometrical and positional tolerances of bearing seating surfaces

Bearing tolerance class		Bearing seating surface	Standard tolerance grades to ISO 286-1 (IT grades)			
to ISO 492	to DIN 620		Diameter tolerance	Roundness tolerance	Parallelism tolerance	Total axial runout tolerance of abutment shoulder
				t_1	t_2	t_3
Normal	PN (P0)	Shaft	IT6 (IT5)	Circumferential load IT4/2	Circumferential load IT4/2	IT4
				Point load IT5/2	Point load IT5/2	
		Housing	IT7 (IT6)	Circumferential load IT5/2	Circumferential load IT5/2	IT5
				Point load IT6/2	Point load IT6/2	

6
Numerical values for ISO standard tolerances (IT grades) to ISO 286-1:2010

IT grade	Nominal dimension in mm							
	over	18	30	50	80	120	180	250
	incl.	30	50	80	120	180	250	315
Values in μm								
IT4	6	7	8	10	12	14	16	
IT5	9	11	13	15	18	20	23	
IT6	13	16	19	22	25	29	32	
IT7	21	25	30	35	40	46	52	

Roughness of cylindrical bearing seating surfaces

Ra must not be too high

The roughness of the bearing seats must be matched to the tolerance class of the bearings. The mean roughness value Ra must not be too high, in order to maintain the interference loss within limits. The shafts must be ground, while the bores must be precision turned. Guide values as a function of the IT grade of bearing seating surfaces ▶491| 7.

7
Roughness values for cylindrical bearing seating surfaces – guide values

Nominal diameter of the bearing seat d (D)		Recommended mean roughness value for ground bearing seats Ramax			
mm		μm			
		Diameter tolerance (IT grade)			
over	incl.	IT7	IT6	IT5	IT4
–	80	1,6	0,8	0,4	0,2
80	500	1,6	1,6	0,8	0,4



☞ *The contact surfaces for the rings must be of sufficient height*

Mounting dimensions for the contact surfaces of bearing rings

The mounting dimensions of the shaft and housing shoulders, and spacer rings etc., must ensure that the contact surfaces for the bearing rings are of sufficient height. The transition from the bearing seat to the abutment shoulder must be designed with rounding to DIN 5418:1993 or an undercut to DIN 509:2006. Proven mounting dimensions for the radii and diameters of abutment shoulders are given in the product tables >494| and >492| 13. These dimensions are limiting dimensions (maximum or minimum dimensions); the actual values should not be higher or lower than specified.

☞ *Rib support in axially loaded bearings*

Ribs under axial load must be supported over their entire height and entire circumference. The size and axial runout accuracy of the contact surfaces on the inner ring rib must be observed especially in the case of cylindrical roller bearings subjected to high loads, since these factors also influence the uniformity of the rib load and the running accuracy of the shaft. This means that the ribs may be subjected to damaging alternating stresses even in the case of very small misalignments. If the mounting dimensions indicated in the product tables are observed, the problems described can be reliably avoided >492| 13 and >494|.

☞ *Support in semi-locating bearings*

In semi-locating bearings, it is sufficient to support the bearing rings on one side, on the rib supporting the axial load >492| 13.



Support of the inner ring rib – bearing with disc cage LSL 1923 (semi-locating bearing)

d_c = recommended height of shaft shoulder with axially loaded rib
Arrow = force flow

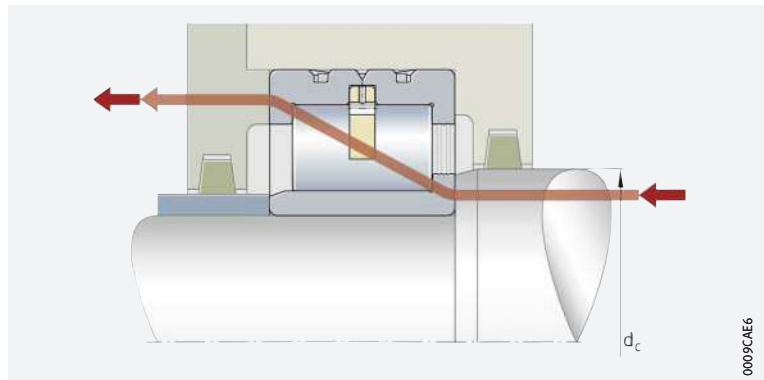

2.17 Mounting and dismounting



The mounting and dismounting options for cylindrical roller bearings, by thermal, hydraulic or mechanical methods, must be taken into consideration in the design of the bearing position.

☞ *As the bearings are not self-retaining, they are easy to mount*

The cylindrical roller bearings LSL 1923 and ZSL 1923 are not self-retaining. As a result, the bearing parts can be mounted separately from each other >478| 2.1. This gives simplified mounting of the bearings, especially when the two bearing rings have a tight fit.

☞ *Rolling bearings must be handled with great care*

Schaeffler Mounting Handbook

Rolling bearings are well-proven precision machine elements for the design of economical and reliable bearing arrangements, which offer high operational security. In order that these products can function correctly and achieve the envisaged operating life without detrimental effect, they must be handled with care.



The Schaeffler Mounting Handbook MH 1 gives comprehensive information about the correct storage, mounting, dismounting and maintenance of rotary rolling bearings ► <https://www.schaeffler.de/std/1D53>. It also provides information which should be observed by the designer, in relation to the mounting, dismounting and maintenance of bearings, in the original design of the bearing position. This book is available from Schaeffler on request.

2.18 Legal notice regarding data freshness

☞ The further development of products may also result in technical changes to catalogue products

Of central interest to Schaeffler is the further development and optimisation of its products and the satisfaction of its customers. In order that you, as the customer, can keep yourself optimally informed about the progress that is being made here and with regard to the current technical status of the products, we publish any product changes which differ from the printed version in our electronic product catalogue.



We therefore reserve the right to make changes to the data and illustrations in this catalogue. This catalogue reflects the status at the time of printing. More recent publications released by us (as printed or digital media) will automatically precede this catalogue if they involve the same subject. Therefore, please always use our electronic product catalogue to check whether more up-to-date information or modification notices exist for your desired product.

Link to electronic product catalogue



The following link will take you to the Schaeffler electronic product catalogue: ► <https://medias.schaeffler.com>.



2.19 Further information



In addition to the data in this chapter, the following chapters in Technical principles must also be observed in the design of bearing arrangements:

- Determining the bearing size ► 34
- Rigidity ► 54
- Friction and increases in temperature ► 56
- Speeds ► 64
- Bearing data ► 97
- Lubrication ► 70
- Sealing ► 182
- Design of bearing arrangements ► 139
- Mounting and dismounting ► 191.



Cylindrical roller bearings with disc cage

Semi-locating bearings

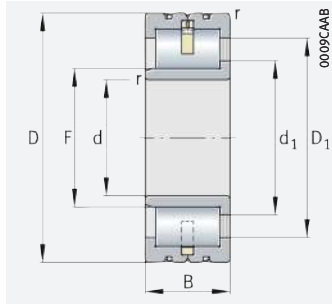

LSL 1923

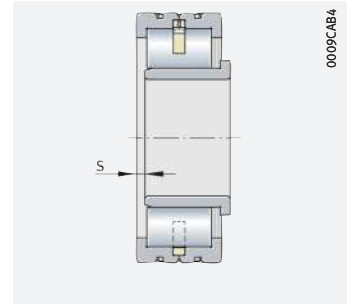

Axial displacement "s"

d = 80 – 300 mm

Main dimensions			Basic load ratings		Fatigue limit load	Limiting speed	Speed rating	Mass	Designation
d	D	B	dyn. C _r	stat. C _{0r}	C _{ur}	n _G	n _{Dr}	m	▶ 488 2.12 ▶ 488 2.13 X-life ▶ 480
			N	N	N	min ⁻¹	min ⁻¹	≈ kg	
80	170	58	420 000	495 000	75 000	8 500	4 600	6,1	LSL192316
85	180	60	445 000	520 000	75 000	8 000	4 350	7,3	LSL192317
90	190	64	590 000	610 000	108 000	7 500	4 050	8,6	LSL192318-TB-XL
95	200	67	610 000	660 000	116 000	7 000	3 750	10	LSL192319-TB-XL
100	215	73	750 000	790 000	137 000	6 600	3 450	12,8	LSL192320-TB-XL
110	240	80	880 000	930 000	156 000	5 800	3 000	17,3	LSL192322-TB-XL
120	260	86	1 060 000	1 140 000	186 000	5 300	2 650	22	LSL192324-TB-XL
130	280	93	1 190 000	1 280 000	206 000	4 900	2 450	27,2	LSL192326-TB-XL
140	300	102	1 340 000	1 460 000	230 000	4 600	2 300	34	LSL192328-TB-XL
150	320	108	1 410 000	1 760 000	200 000	4 250	2 020	40,7	LSL192330-TB
160	340	114	1 600 000	2 010 000	223 000	3 900	1 820	48,1	LSL192332-TB
170	360	120	1 740 000	2 210 000	244 000	3 750	1 760	57,5	LSL192334-TB
180	380	126	1 840 000	2 430 000	265 000	3 500	1 620	67,4	LSL192336-TB
190	400	132	2 100 000	2 750 000	295 000	3 400	1 540	78,1	LSL192338-TB
200	420	138	2 340 000	3 050 000	320 000	3 200	1 420	89,3	LSL192340-TB
220	460	145	2 500 000	3 200 000	330 000	2 850	1 270	108	LSL192344-TB
240	500	155	2 750 000	3 550 000	355 000	2 700	1 220	138,6	LSL192348-TB
260	540	165	3 350 000	4 350 000	425 000	2 380	1 010	168	LSL192352-TB
280	580	175	3 700 000	4 850 000	460 000	2 250	950	206,6	LSL192356-TB
300	620	185	4 150 000	5 500 000	520 000	2 130	890	253	LSL192360-TB

medias ▶ <https://www.schaeffler.de/std/1E73>

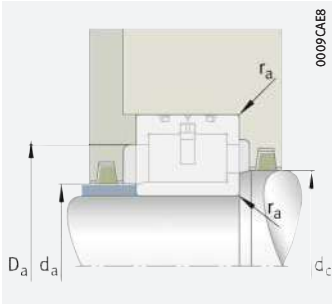

Mounting dimensions

Dimensions						Mounting dimensions			
d	r	s	F	d ₁	D ₁	d _a	d _c	D _a	r _a
	min.			≈	≈				max.
80	2,1	3,5	94	104,5	134,8	94	104,5	134,5	2,1
85	3	4	100	111,3	143,9	100	111,5	143,5	3
90	3	4	105,3	117,2	152,5	105	117,5	152,5	3
95	3	4	114,7	126,6	161	114,5	127	161	3
100	3	4	119,3	132,7	172	119	133	172	3
110	3	5	135,5	150,7	193,1	135,5	151	193	3
120	3	5	147,4	164,2	213,1	147	164,5	213	3
130	4	5	157,9	176	227,9	157,5	176	227,5	4
140	4	7	168,5	187,5	243,2	168	187,5	243	4
150	4	7	182,5	203,3	263,9	182	203,5	263,5	4
160	4	7	196,4	219	284,8	196	219	284,5	4
170	4	7	230,6	226,6	295,4	230,5	227	295	4
180	4	7	221,6	245	313,3	221,5	245	313	4
190	5	7	224,4	250	325,5	224	250	325,5	5
200	5	7	238,5	265,7	345,9	238	266	345,5	5
220	5	7	266,7	297	385,9	266,5	297	385,5	5
240	5	10	280,6	312,5	406,1	280,5	312,5	406	5
260	6	10	315,6	351,6	457,2	315,5	352	457	6
280	6	12	333,1	371	485	333	371	485	6
300	7,5	12	350,9	390,9	508,5	350,5	391	508,5	7,5





Cylindrical roller bearings with spacers

Semi-locating bearings

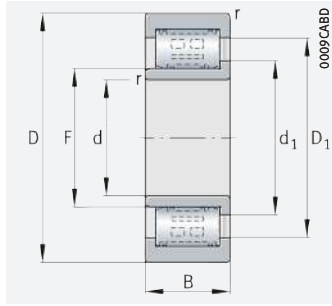

ZSL 1923

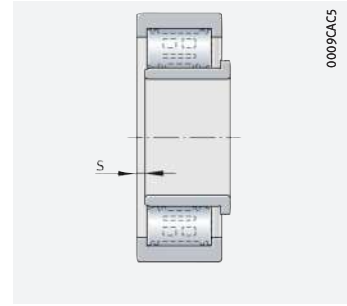

Axial displacement "s"

d = 25 – 120 mm

Main dimensions			Basic load ratings		Fatigue limit load C_{Ur}	Limiting speed n_G	Speed rating n_{Dr}	Mass m	Designation
d	D	B	dyn. C_r	dyn. C_{0r}					
			N	N	N	min^{-1}	min^{-1}	≈ kg	
25	62	24	60 000	54 000	7 000	17 100	10 000	0,36	ZSL192305
30	72	27	83 000	80 000	10 800	14 400	8 500	0,55	ZSL192306
35	80	31	105 000	101 000	15 100	12 300	7 500	0,72	ZSL192307
40	90	33	141 000	142 000	21 300	10 600	6 300	1	ZSL192308
45	100	36	151 000	157 000	23 700	9 900	6 300	1,34	ZSL192309
50	110	40	193 000	199 000	30 000	8 900	5 800	1,76	ZSL192310
55	120	43	224 000	231 000	36 000	8 000	5 400	2,22	ZSL192311
60	130	46	240 000	255 000	40 000	7 400	5 200	2,82	ZSL192312
65	140	48	295 000	320 000	50 000	6 700	4 600	3,44	ZSL192313
70	150	51	325 000	355 000	55 000	6 400	4 600	4,27	ZSL192314
75	160	55	385 000	435 000	65 000	5 900	4 200	5,2	ZSL192315
80	170	58	450 000	520 000	75 000	5 500	3 850	6,2	ZSL192316
85	180	60	480 000	570 000	81 000	5 100	3 600	7,23	ZSL192317
90	190	64	590 000	610 000	108 000	5 100	3 750	8,7	ZSL192318-TB-XL
95	200	67	620 000	660 000	116 000	4 750	3 450	10	ZSL192319-TB-XL
100	215	73	750 000	790 000	137 000	4 450	3 200	12,7	ZSL192320-TB-XL
110	240	80	890 000	900 000	148 000	3 850	2 700	16,5	ZSL192322-TB-XL
120	260	86	1 060 000	1 140 000	186 000	3 600	2 400	21,9	ZSL192324-TB-XL

medias ► <https://www.schaeffler.de/std/1E74>

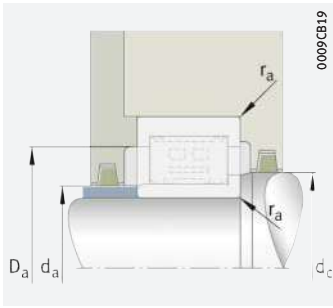

Mounting dimensions

Dimensions						Mounting dimensions			
d	r	s	F	d ₁	D ₁	d _a	d _c	D _a	r _a
	min.			≈	≈				max.
25	1,1	2	31,7	36,7	47,5	31,5	37	47,5	1,1
30	1,1	2	38,3	43,5	56	38	43,5	56	1,1
35	1,5	2	44,7	50,7	65,8	44,5	51	65,5	1,5
40	1,5	2	51,1	57,5	75,2	51	57,5	75	1,5
45	1,5	3	56,1	62,5	80,3	56	62,5	80	1,5
50	2	3	60,7	68,3	89,7	60,5	68,5	89,5	2
55	2	3	67,1	75,5	99,3	67	75,5	99	2
60	2,1	3	73,6	82	105,8	73,5	82	105,5	2,1
65	2,1	3,5	80,7	90	116,5	80,5	90	116,5	2,1
70	2,1	3,5	84,1	93,5	121,6	84	93,5	121,5	2,1
75	2,1	3,5	91,2	101,6	131,9	91	102	131,5	2,1
80	2,1	3,5	98,2	109,5	142,1	98	109,5	142	2,1
85	3	4	107	118,5	150,9	107	118,5	150,5	3
90	3	4	105,3	117,5	152,5	105	117,5	152,5	3
95	3	4	114,7	126,6	161,9	114,5	127	161,5	3
100	3	4	119,3	132,7	172,8	119	133	172,5	3
110	3	5	134,3	151,1	199,9	134	151,5	199,5	3
120	3	5	147,4	164,2	213,1	147	164,5	213	3



3 Single row full complement cylindrical roller bearings



Single row full complement cylindrical roller bearings are suitable where:

- bearing arrangements are subjected to particularly high radial loads ▶ 501 | 3.2
- not only very high radial forces but also high axial loads from one direction must be supported by the bearing position (semi-locating bearing function) ▶ 501 | 3.2
- bearing arrangements operating under the conditions described above must have very high rigidity
- axial displacements of the shaft relative to the housing must be compensated without constraint in the bearing ▶ 498 | 3.1
- very high radial loads occur at lower speeds, i.e. the bearings do not need to achieve speeds as high as those of cylindrical roller bearings with cage ▶ 504 | 3.6 and ▶ 514 | 3.6
- particularly space-saving designs are required despite very high load
- the bearings should be separable (not self-retaining) for easier mounting ▶ 498 | 3.1.

For an overview of other product-specific features, see the Matrix for bearing preselection ▶ 410.

1
Cylindrical roller bearing with cage/full complement bearing, comparison of speed and load carrying capacity

C_r = basic dynamic load rating
 n_G = limiting speed

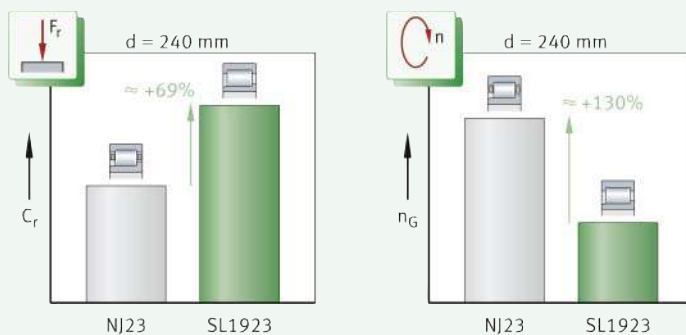

3.1 Bearing design

Design variants

Single row full complement cylindrical roller bearings are available as:



- series SL1818, SL1829, SL1830, SL1822 (semi-locating bearings) ▶ 499 | 3.2
- series SL1923 (semi-locating bearings) ▶ 499 | 3.3
- X-life bearings ▶ 500.



In addition to the bearings described here, Schaeffler supplies single row full complement cylindrical roller bearings in other types, series and dimensions. These products are described in some cases in special publications. If necessary, please contact Schaeffler. Larger catalogue bearings ▶ GL 1.

Bearings of basic design – standard range

Key features

Single row full complement cylindrical roller bearings are part of the group of radial roller bearings. These bearings comprise solid outer rings, inner rings and full complement rolling element sets. Due to the absence of a cage, the bearing can accommodate the largest possible number of rolling elements. The rollers have profiled ends, i.e. they have a slight lateral curvature towards the ends. This modified line contact between the rolling elements and raceways prevents damaging edge stresses **► 413** |  2. The series SL1923 is self-retaining. Certain sizes are also available in an increased capacity design **► 514** |  6. These bearings have the suffix E **► 507** |  6.

Bearings with semi-locating bearing function

Series SL1818, SL1829, SL1830, SL1822
 In these bearings, the outer ring has one rigid rib and the inner ring has two rigid ribs **► 499** |  2. As a result, axial displacements of the shaft relative to the housing can be compensated within certain limits. The maximum axial displacement *s* is given in the product tables. Since the axial motion occurs without constraint in the bearing itself, this is practically free from friction with a rotating bearing. Cylindrical roller bearings of this design are used as semi-locating bearings, i.e. they can guide the shaft axially in one direction, while they act in the opposite direction as non-locating bearings **► 501** | 3.2.



The bearings are held together in handling and mounting by a transport and mounting retaining device on the outer ring **► 499** |  2. This retaining device remains in the bearing even after mounting and must not be subjected to axial load.



 2
 Single row full complement cylindrical roller bearing – semi-locating bearing

F_r = radial load
 F_a = axial load

① Transport and mounting retaining device

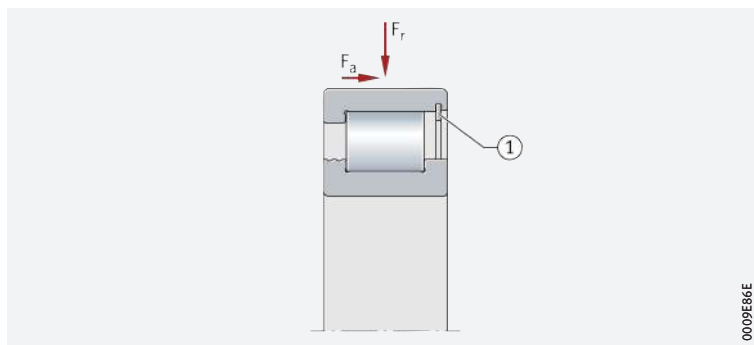

Series SL1923

Bearings with semi-locating bearing function

Cylindrical roller bearings of this design have two rigid ribs on the outer ring and a self-retaining rolling element set, while the inner ring has only one rigid rib **► 499** |  3. As a result, the inner ring can be removed from the bearing. This gives easier mounting of the cylindrical roller bearings. The bearings are used as semi-locating bearings, i.e. they can guide the shaft axially in one direction **► 501** | 3.2 and permit axial displacements in the bearing between the shaft and housing in one direction. The maximum axial displacement *s* is given in the product tables.

 3
 Single row full complement cylindrical roller bearing

F_r = radial load
 F_a = axial load

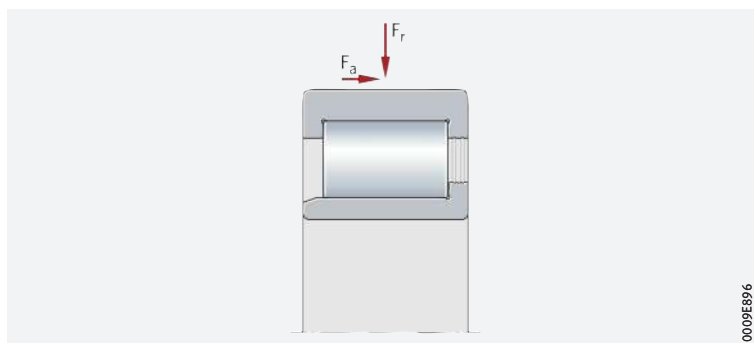

X-life

X-life premium quality

Many sizes are available as X-life bearings $\blacktriangleright 500$ | $\oplus 4$. These bearings exhibit considerably higher performance than comparable standard cylindrical roller bearings. This is achieved, for example, through the modified internal construction, the optimised contact geometry between the rollers and raceways, better surface quality and the optimised roller guidance and lubricant film formation.

$\oplus 4$

Single row full complement cylindrical roller bearing in X-life design

- ① Cylindrical roller, honed
- ② Outer ring, honed
- ③ Inner ring, honed

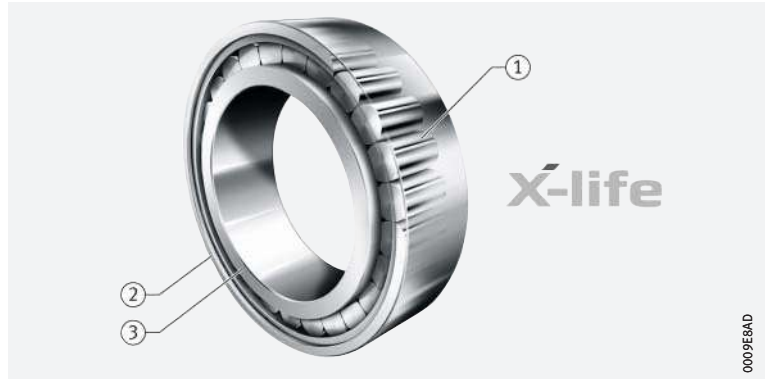

Advantages

Increased customer benefits due to X-life

These technical enhancements offer a range of advantages, such as:

- a more favourable load distribution in the bearing and thus a higher dynamic load carrying capacity of the bearings
- a higher fatigue limit load
- lower heat generation in the bearing
- lower lubricant consumption and therefore longer maintenance intervals if relubrication is carried out
- a measurably longer operating life of the bearings
- high operational security
- compact, environmentally-friendly bearing arrangements.

Interchangeable with comparable standard bearings

Since the single row full complement X-life cylindrical roller bearings have the same dimensions as the corresponding standard bearings, the latter can be replaced without any problems by the higher-performance X-life bearings. The major advantages of X-life can therefore also be used for existing bearing arrangements with standard bearings.

Lower operating costs, higher machine availability

In conclusion, these advantages improve the overall cost-efficiency of the bearing position significantly and thus bring about a sustainable increase in the efficiency of the machine and equipment.

Suffix XL

X-life cylindrical roller bearings include the suffix XL in the designation $\blacktriangleright 507$ | 3.12 and $\blacktriangleright 514$ | $\oplus 4$.

Areas of application

Due to their special technical features, single row full complement X-life cylindrical roller bearings are highly suitable, for example, for bearing arrangements in:

- heavy industry (steel production)
- power transmission (gearbox engineering)
- processing machines and construction machinery
- wind turbines (gearbox applications).



X-life indicates a high product performance density and thus a particularly significant benefit to the customer. Further information on X-life $\blacktriangleright 10$.

3.2 Load carrying capacity

☞ *Designed for very high radial loads*

Due to the absence of a cage, the bearing can accommodate the largest possible number of rolling elements. As a result, full complement cylindrical roller bearings have very high radial load carrying capacity.

Higher axial load carrying capacity of bearings with toroidal crowned roller end face

☞ *Neither wear nor material fatigue occurs on the rib contact running and roller end faces*

In the case of cylindrical roller bearings with toroidal crowned rollers (TB design), the axial load carrying capacity has been significantly improved with the aid of new calculation and manufacturing methods. A special curvature of the roller end faces facilitates optimum contact conditions between the rollers and ribs ➤ 501 | ☐ 5. As a result, the axial contact pressures on the rib are significantly minimised and a lubricant film capable of supporting higher loads is formed. Under standard operating conditions, this completely eliminates wear and fatigue at the rib contact running and roller end faces. In addition, the axial frictional torque is reduced by up to 50%. The bearing temperature during operation is therefore significantly lower. Available bearings of toroidal crowned design ➤ 501 | ☐ 1.

☐ 5
Contact geometry of roller end face/rib face – modified roller end faces

- ① Cylindrical roller with inner ring
- ② Detail (representation not to scale)
- ③ End of roller
- ④ Rib

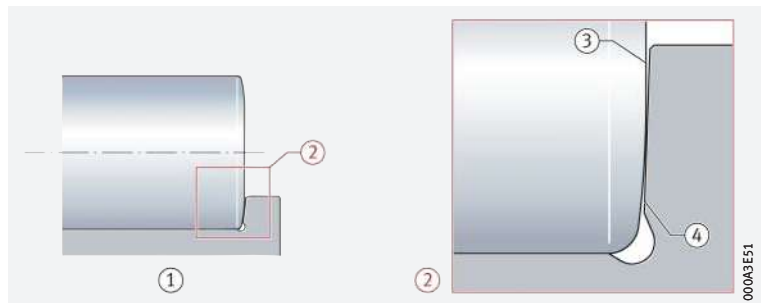

☐ 1
Single row full complement cylindrical roller bearings with toroidal crowned roller ends available by agreement

Series	Bore diameter d mm from
SL1818	460
SL1822	140
SL1829	300
SL1830	180
SL1923	90

Load ratio F_a/F_r

☞ *Ratio $F_a/F_r \leq 0,4$ or $0,6$*

The bearings can support axial loads on one side by means of the ribs on the inner and outer ring ➤ 502 | ☐ 6. In order to ensure problem-free running (tilting of the rollers is prevented), they must always be subjected to radial load at the same time as axial load. The ratio F_a/F_r must not exceed the value 0,4. For bearings with toroidal crowned roller ends (TB design), values up to 0,6 are permissible.



Continuous axial loading without simultaneous radial loading is not permissible.

Permissible axial load

Influencing factors on the axial load carrying capacity

Axial loads are supported by the bearing ribs and the roller end faces **► 502** | 6. The axial load carrying capacity of the bearing is therefore essentially dependent on:

- the size of the sliding surfaces between the ribs and the end faces of the rolling elements
- the sliding velocity at the ribs
- the lubrication of the contact surfaces
- tilting of the bearing
- friction.

6
Force flow under axial load – semi-locating bearing SL1923

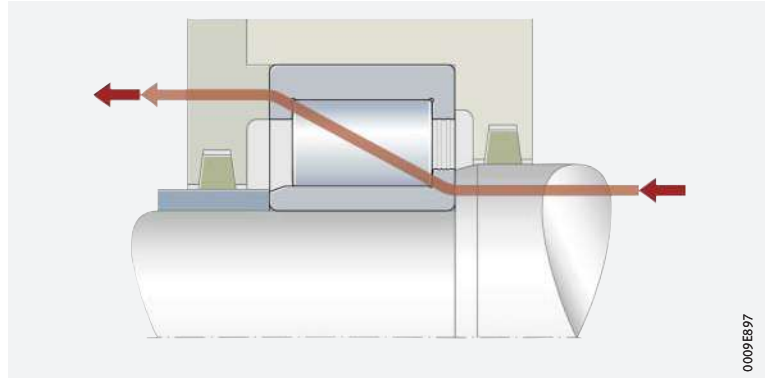

Calculation of permissible axial load – cylindrical rollers with conventional roller ends

Bearings with standard roller ends

The permissible axial load $F_{a\text{per}}$ can be calculated from the hydrodynamic load carrying capacity of the contact **► 502** | 1.

1
Permissible axial load – bearings of standard design

$$F_{a\text{per}} = k_S \cdot k_B \cdot d_M^{1,54} \cdot n^{-0,6} \leq F_{a\text{max}}$$

Legend

$F_{a\text{per}}$	N	Permissible continuous axial load. In order to prevent unacceptably high temperatures in the bearing, $F_{a\text{per}}$ must not be exceeded
$F_{a\text{max}}$	N	Maximum continuous axial load in relation to rib fracture. In order to prevent unacceptably high pressures at the contact surfaces, $F_{a\text{max}}$ must not be exceeded
k_S	–	Factor as a function of lubrication method ► 502 2. The factor takes into consideration the lubrication method used for the bearing. The better the lubrication and, in particular, the heat dissipation, the higher the permissible axial load
k_B	–	Factor as a function of the bearing series ► 503 3
d_M	mm	Mean bearing diameter $d_M = (D + d)/2$ ► 514
n	min ⁻¹	Operating speed.

2
Factor k_S

Lubrication method	Factor k_S	
	from	up to
Minimal heat dissipation, drip feed oil lubrication, oil mist lubrication, low operating viscosity ($\nu < 0,5 \cdot \nu_1$)	7,5	10
Poor heat dissipation, oil sump lubrication, oil spray lubrication, low oil flow	10	15
Good heat dissipation, recirculating oil lubrication (pressurised oil lubrication)	12	18
Very good heat dissipation, recirculating oil lubrication with oil cooling, high operating viscosity ($\nu > 2 \cdot \nu_1$)	16	24



The precondition for these k_S values is an operating viscosity of the lubricant of at least the reference viscosity ν_1 in accordance with DIN ISO 281:2010.



Doped lubricating oils should be used, such as CLP (DIN 51517) and HLP (DIN 51524) of ISO VG grades 32 to 460, as well as ATF oils (DIN 51502) and transmission oils (DIN 51512) of SAE viscosity grades 75W to 140W.

3
Bearing factor k_B

Series	k_B
SL1818	4,5
SL1829	11
SL1830	17
SL1822	20
SL1923	30

Calculation of permissible axial load – cylindrical rollers with toroidal crowned roller ends

For bearings with toroidal roller ends, the permissible axial loads are 50% higher 503 | 2.

2
Permissible axial load – bearings of TB design

$$F_{a\text{ per}} = 1,5 \cdot k_S \cdot k_B \cdot d_M^{1,54} \cdot n^{-0,6} \leq F_{a\text{ max}}$$

Calculation of maximum permissible axial load



The maximum permissible axial load $F_{a\text{ max}}$ 503 | 3 is calculated from the rib strength and security against wear. This must not be exceeded, even if $F_{a\text{ per}}$ gives higher values 503 | 4.

3
Maximum axial load – bearings of standard and TB design

$$F_{a\text{ max}} = 0,075 \cdot k_B \cdot d_M^{2,1}$$

4
Permissible axial load

$$F_{a\text{ per}} \leq F_{a\text{ max}}$$

Axial load under shaft deflection

Permissible axial load under shaft deflection of up to $2'$

Under considerable shaft deflection, the shaft shoulder presses against the inner ring rib. In combination with the active axial load, this can lead to high alternating loading of the inner ring ribs. Under a shaft deflection of up to $2'$, the permissible axial load can be estimated 503 | 5.



If more severe tilting is present, a separate strength analysis is required. In this case, please contact Schaeffler.

5
Axial load under misalignment

$$F_{a\text{ s}} = 20 \cdot d_M^{1,42}$$

Legend

$F_{a\text{ s}}$ | N | Permissible axial load under misalignment.

3.3 Compensation of angular misalignments

Angular deviations are misalignments between the inner and outer ring

The possible misalignment between the inner ring and outer ring is influenced by the internal bearing construction, the operating clearance, the forces acting on the bearing etc. Due to these complex relationships, it is not possible to give generally valid absolute values here.

However, misalignments (angular deviations) between the inner ring and outer ring will generally always have an effect on the running noise and the operating life of the bearings.

Permissible tilting

The permissible guide values at which, based on experience, there is no significant reduction in operating life are as follows:

- $4'$ for series SL1818
- $3'$ for series SL1923, SL1822, SL1829, SL1830.

 *Scope of values*

The stated values apply to:

- bearing arrangements with static misalignment (consistent position of the shaft and housing axis)
- bearings that are not required to perform an axial guidance function
- bearings subjected to small loads (with $C_{0r}/P \geq 5$).



Checking by means of the calculation program BEARINX is recommended in all cases. If there is any uncertainty regarding possible misalignment, please consult Schaeffler.

3.4 Lubrication

 *Oil or grease lubrication is possible*

The cylindrical roller bearings are not greased. They must be lubricated with oil or grease.



If there is any uncertainty regarding the suitability of the selected lubricant for the application, please consult Schaeffler or the lubricant manufacturer.

 *Observe oil change intervals*

Aged oil and additives in the oil can impair the operating life of plastics at high temperatures. As a result, stipulated oil change intervals must be strictly observed.

3.5 Sealing

 *Provide seals in the adjacent construction*

The bearings are not sealed, i.e. sealing of the bearing position must be carried out in the adjacent construction. This must reliably prevent:

- moisture and contaminants from entering the bearing
- the egress of lubricant from the bearing.

3.6 Speeds

 *Limiting speeds and reference speeds in the product tables*

The product tables give two speeds for most bearings :

- the kinematic limiting speed n_G
- the thermal speed rating $n_{\vartheta r}$.

 *Lower speed capacity than bearings with cage*

Due to the kinematic conditions, however, bearings without cage do not achieve the high speeds that are possible when using bearings with cage.

Limiting speeds



The limiting speed n_G is the kinematically permissible speed of the bearing. Even under favourable mounting and operating conditions, this value should not be exceeded without prior consultation with Schaeffler .

Reference speeds

 *$n_{\vartheta r}$ is used to calculate n_{ϑ}*

The thermal speed rating $n_{\vartheta r}$ is not an application-oriented speed limit, but is a calculated ancillary value for determining the thermally safe operating speed n_{ϑ} .

3.7 Noise

The Schaeffler Noise Index (SGI) has been developed as a new feature for comparing the noise level of different bearing types and series. As a result, a noise evaluation of rolling bearings can now be carried out for the first time.

Schaeffler Noise Index

The SGI value is based on the maximum permissible noise level of a bearing in accordance with internal standards, which is calculated on the basis of ISO 15242. In order that different bearing types and series can be compared, the SGI value is plotted against the basic static load rating C_0 .

This permits direct comparisons between bearings with the same load carrying capacity. The upper limit value is given in each of the diagrams. This means that the average noise level of the bearings is lower than illustrated in the diagram.

 The Schaeffler Noise Index is an additional performance characteristic in the selection of bearings for noise-sensitive applications. The specific suitability of a bearing for an application in terms of installation space, load carrying capacity or speed limit for example, must be checked independently of this.

 The Noise Index is currently available for the main series. Additional series will be updated and introduced in subsequent publications.

Further information:

■ **medias** ► <https://medias.schaeffler.com>.

Schaeffler Noise Index for single row full complement cylindrical roller bearings

SGI = Schaeffler Noise Index

C_0 = basic static load rating

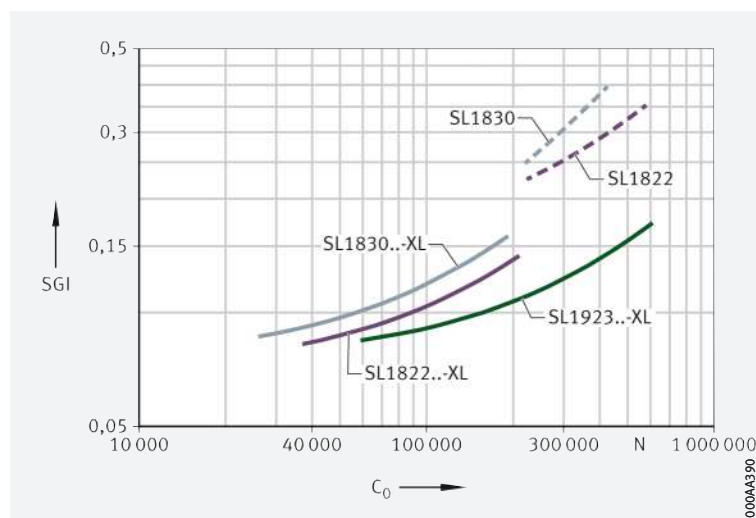

3.8 Temperature range

Limiting values

The operating temperature of the bearings is limited by:

- the dimensional stability of the bearing rings and cylindrical rollers
- the cage
- the lubricant.

Possible operating temperatures of single row cylindrical roller bearings ► 505 |  4.

Permissible temperature ranges

Operating temperature	Single row full complement cylindrical roller bearings
	-30 °C to +120 °C



In the event of anticipated temperatures which lie outside the stated values, please contact Schaeffler.



3.9 Cages

Full complement cylindrical roller bearings do not have a cage for guidance and separation of the rolling elements. The cylindrical rollers are guided by the ribs on the bearing rings.

3.10 Internal clearance

Radial internal clearance



 The standard is CN

Single row full complement cylindrical roller bearings are manufactured as standard with the radial internal clearance CN (normal)  506 |  5. CN is not stated in the designation.



Certain sizes are also available by agreement with the larger internal clearance C3, C4 and C5  506 |  5.



The values for radial internal clearance correspond to DIN 620-4:2004 (ISO 5753-1:2009)  506 |  5. They are valid for bearings which are free from load and measurement forces (without elastic deformation).

 5
Radial internal clearance
of single row full complement
cylindrical roller bearings

Nominal bore diameter d mm		Radial internal clearance							
		CN (Group N)		C3 (Group 3)		C4 (Group 4)		C5 (Group 5)	
		μm		μm		μm		μm	
over	incl.	min.	max.	min.	max.	min.	max.	min.	max.
–	24	20	45	35	60	50	75	65	90
24	30	20	45	35	60	50	75	70	95
30	40	25	50	45	70	60	85	80	105
40	50	30	60	50	80	70	100	95	125
50	65	40	70	60	90	80	110	110	140
65	80	40	75	65	100	90	125	130	165
80	100	50	85	75	110	105	140	155	190
100	120	50	90	85	125	125	165	180	220
120	140	60	105	100	145	145	190	200	245
140	160	70	120	115	165	165	215	225	275
160	180	75	125	120	170	170	220	250	300
180	200	90	145	140	195	195	250	275	330
200	225	105	165	160	220	220	280	305	365
225	250	110	175	170	235	235	300	330	395
250	280	125	195	190	260	260	330	370	440
280	315	130	205	200	275	275	350	410	485
315	355	145	225	225	305	305	385	455	535
355	400	190	280	280	370	370	460	510	600
400	450	210	310	310	410	410	510	565	665
450	500	220	330	330	440	440	550	625	735

3.11 Dimensions, tolerances

Dimension standards





The main dimensions of cylindrical roller bearings correspond to ISO 15:2017 (DIN 616:2000 and DIN 5412-1:2005).

Chamfer dimensions





The limiting dimensions for chamfer dimensions correspond to DIN 620-6:2004. Overview and limiting values  135 | 7.11.

Nominal value of chamfer dimension  514 | .

Tolerances



The dimensional and running tolerances of the cylindrical roller bearings correspond to the tolerance class Normal in accordance with ISO 492:2014. Tolerance values in accordance with ISO 492  122 |  8.

3.12 Suffixes

For a description of the suffixes used in this chapter ▶ 507 | 6 and **medias** interchange ▶ <https://www.schaeffler.de/std/1D52>.

6
Suffixes and
corresponding descriptions

Suffix	Description of suffix	Availability
BR	Black oxide coated	Available by agreement
C3	Radial internal clearance C3 (larger than normal)	
C4	Radial internal clearance C4 (larger than C3)	
C5	Radial internal clearance C5 (larger than C4)	
E	Increased capacity design	Standard, dependent on bore code and bearing series; others available by agreement
TB	Bearing with increased axial load carrying capacity	
XL	X-life bearing	

3.13 Structure of bearing designation

Example of composition of bearing designation

The designation of bearings follows a set model. Example ▶ 507 | 8. The composition of designations is subject to DIN 623-1 ▶ 102 | 10.

8
Single row full complement cylindrical roller bearing (semi-locating bearing): designation structure

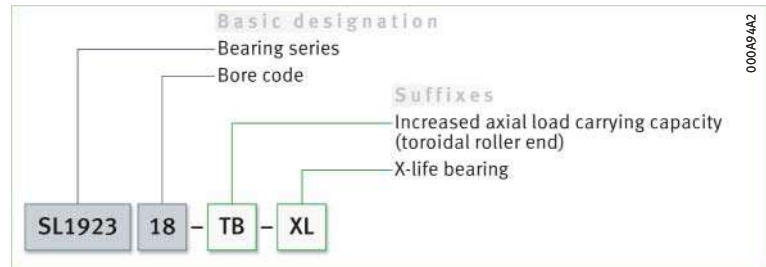

3.14 Dimensioning

Equivalent dynamic bearing load

$P = F_r$ under purely radial load of constant magnitude and direction

The basic rating life equation $L = (C_r/P)^P$ used in the dimensioning of bearings under dynamic load assumes a load of constant magnitude and direction. In radial bearings, this is a purely radial load F_r . If this condition is met, the bearing load F_r is used in the rating life equation for P ($P = F_r$).

P is a substitute force for combined load and various load cases

Cylindrical roller bearings with semi-locating bearing function

If the condition described above is not met, i.e. if, in addition to the radial force F_r , there is also an axial force F_a , a constant radial force must first be determined for the rating life calculation that (in relation to the rating life) represents an equivalent load. This force is known as the equivalent dynamic bearing load P .

$F_a/F_r \leq e$ or $F_a/F_r > e$

The calculation of P is dependent on the load ratio F_a/F_r and the calculation factors e and Y ▶ 507 | 6 and ▶ 508 | 7.

6
Equivalent dynamic load

$$\frac{F_a}{F_r} \leq e \Rightarrow P = F_r$$

f17
Equivalent dynamic load

$$\frac{F_a}{F_r} > e \Rightarrow P = 0,92 \cdot F_r + Y \cdot F_a$$

Legend

P	N	Equivalent dynamic bearing load
F _r	N	Radial load
F _a	N	Axial load
e, Y	-	Factors ▶ 508 7.

7
Factors e and Y

Bearing series	Calculation factors	
	e	Y
SL1818	0,2	0,6
SL1923, SL1822, SL1829, SL1830	0,3	0,4

Equivalent static bearing load

$P_0 = F_{Or}$

For cylindrical roller bearings subjected to static load ▶ 508 | 8.

f18
Equivalent static load

$$P_0 = F_{Or}$$

Legend

P ₀	N	Equivalent static bearing load
F _{Or}	N	Largest radial load present (maximum load).

Static load safety factor

$S_0 = C_0/P_0$

In addition to the basic rating life L (L_{10h}), it is also always necessary to check the static load safety factor S₀ ▶ 508 | 9.

f19
Static load safety factor

$$S_0 = \frac{C_0}{P_0}$$

Legend

S ₀	-	Static load safety factor
C ₀	N	Basic static load rating
P ₀	N	Equivalent static bearing load.

3.15 Minimum load

In order to prevent damage due to slippage, a minimum radial load of $P > C_{Or}/60$ is necessary during continuous operation

In order that no slippage occurs between the contact partners, the cylindrical roller bearings must be constantly subjected to a sufficiently high radial load. For continuous operation, experience shows that a minimum radial load of the order of $P > C_{Or}/60$ is thus necessary. In most cases, however, the radial load is already higher than the requisite minimum load due to the weight of the supported parts and the external forces.



If the minimum radial load is lower than indicated above, please consult Schaeffler.

3.16 Design of bearing arrangements

Support bearing rings over their entire circumference and width

In order to allow full utilisation of the load carrying capacity of the bearings and achieve the requisite rating life, the bearing rings must be rigidly and uniformly supported by means of contact surfaces over their entire circumference and over the entire width of the raceway. Support can be provided by means of a cylindrical seating surface. The seating and contact surfaces should not be interrupted by grooves, holes or other recesses. The accuracy of mating parts must meet specific requirements ▶ 509 | 8 to ▶ 510 | 10.

☞ *For secure radial location, tight fits are necessary*

Radial location

In addition to supporting the rings adequately, the bearings must also be securely located in a radial direction, to prevent creep of the bearing rings on the mating parts under load. This is generally achieved by means of tight fits between the bearing rings and the mating parts. If the rings are not secured adequately or correctly, this can cause severe damage to the bearings and adjacent machine parts. Influencing factors, such as the conditions of rotation, magnitude of the load, internal clearance, temperature conditions, design of the mating parts and the mounting and dismounting options must be taken into consideration in the selection of fits.



If shock type loads occur, tight fits (transition fit or interference fit) are required to prevent the rings from coming loose at any point. Clearance, transition or interference fits ▶ 150 | 6 and ▶ 158 | 7.



The following information provided in Technical principles must be taken into consideration in the design of bearing arrangements:

- conditions of rotation ▶ 145
- tolerance classes for cylindrical shaft seats (radial bearings) ▶ 147 | 2
- shaft fits ▶ 150 | 6
- tolerance classes for bearing seats in housings (radial bearings) ▶ 148 | 4
- housing fits ▶ 158 | 7.



Axial location

☞ *The bearings must also be securely located in an axial direction*

As a tight fit alone is not normally sufficient to also locate the bearing rings securely on the shaft and in the housing bore in an axial direction, this must usually be achieved by means of an additional axial location or retention method. The axial location of the bearing rings must be matched to the type of bearing arrangement. Shaft and housing shoulders, housing covers, nuts, spacer rings, retaining rings, adapter and withdrawal sleeves etc., are fundamentally suitable; example ▶ 511 | 9.

Dimensional, geometrical and running accuracy of cylindrical seats

☞ *A minimum of IT6 should be provided for the shaft seat and a minimum of IT7 for the housing seat*

The accuracy of the cylindrical bearing seat on the shaft and in the housing should correspond to the accuracy of the bearing used. For cylindrical roller bearings with the tolerance class Normal, the shaft seat should correspond to a minimum of standard tolerance grade IT6 and the housing seat to a minimum of IT7. Guide values for the geometrical and positional tolerances of the bearing seating surfaces ▶ 509 | 8, tolerances t_1 to t_3 in accordance with ▶ 168 | 11. Numerical values for IT grades ▶ 510 | 9.

8
Guide values for the geometrical and positional tolerances of bearing seating surfaces

Bearing tolerance class		Bearing seating surface	Standard tolerance grades to ISO 286-1 (IT grades)			
to ISO 492	to DIN 620		Diameter tolerance	Roundness tolerance	Parallelism tolerance	Total axial runout tolerance of abutment shoulder
				t_1	t_2	t_3
Normal	PN (P0)	Shaft	IT6 (IT5)	Circumferential load IT4/2 Point load IT5/2	Circumferential load IT4/2 Point load IT5/2	IT4
		Housing	IT7 (IT6)	Circumferential load IT5/2 Point load IT6/2	Circumferential load IT5/2 Point load IT6/2	

9
Numerical values
for ISO standard tolerances
(IT grades) to ISO 286-1:2010

IT grade	Nominal dimension in mm									
	over	18	30	50	80	120	180	250	315	400
	incl.	30	50	80	120	180	250	315	400	500
Values in μm										
IT4	6	7	8	10	12	14	16	18	20	
IT5	9	11	13	15	18	20	23	25	27	
IT6	13	16	19	22	25	29	32	36	40	
IT7	21	25	30	35	40	46	52	57	63	

Roughness of cylindrical bearing seating surfaces

Ra must not be too high

The roughness of the bearing seats must be matched to the tolerance class of the bearings. The mean roughness value Ra must not be too high, in order to maintain the interference loss within limits. The shafts must be ground, while the bores must be precision turned. Guide values as a function of the IT grade of bearing seating surfaces **► 510** **9** 10.

10
Roughness values
for cylindrical bearing seating
surfaces – guide values

Nominal diameter of the bearing seat d (D) mm		Recommended mean roughness value for ground bearing seats Ramax μm			
		Diameter tolerance (IT grade)			
over	incl.	IT7	IT6	IT5	IT4
–	80	1,6	0,8	0,4	0,2
80	500	1,6	1,6	0,8	0,4

Mounting dimensions for the contact surfaces of bearing rings

The contact surfaces for the rings must be of sufficient height

The mounting dimensions of the shaft and housing shoulders, and spacer rings etc., must ensure that the contact surfaces for the bearing rings are of sufficient height. The transition from the bearing seat to the abutment shoulder must be designed with rounding to DIN 5418:1993 or an undercut to DIN 509:2006. Proven mounting dimensions for the radii and diameters of abutment shoulders are given in the product tables **► 514** **9** and **► 511** **9**. These dimensions are limiting dimensions (maximum or minimum dimensions); the actual values should not be higher or lower than specified.

Rib support in axially loaded bearings

Ribs under axial load must be supported over their entire height and entire circumference **► 511** **9**. The size and axial runout accuracy of the contact surfaces on the inner ring rib must be observed especially in the case of cylindrical roller bearings subjected to high loads, since these factors also influence the uniformity of the rib load and the running accuracy of the shaft. This means that the ribs may be subjected to damaging alternating stresses even in the case of very small misalignments. If the mounting dimensions indicated in the product tables are observed, the problems described can be reliably avoided **► 514** **9**.

Support in semi-locating bearings

In semi-locating bearings, it is sufficient to support the bearing rings on one side, on the rib supporting the axial load **► 511** **9**.



Support of the inner ring rib – series SL1923 (semi-locating bearing)

d_c = recommended height of shaft shoulder with axially loaded rib
 Arrow = force flow

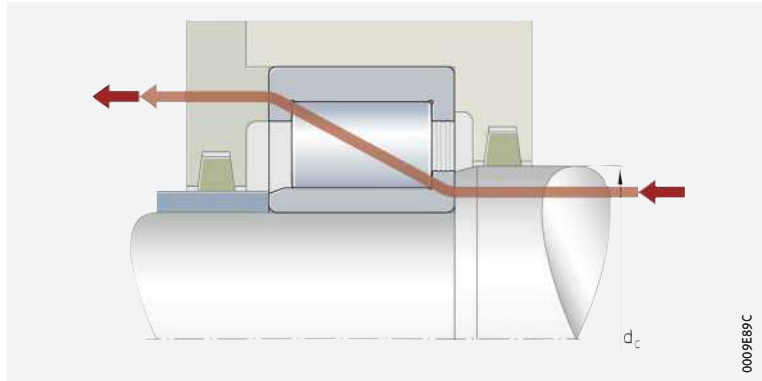

3.17 Mounting and dismounting



The mounting and dismounting options for cylindrical roller bearings, by thermal, hydraulic or mechanical methods, must be taken into consideration in the design of the bearing position.

Rolling bearings must be handled with great care

Schaeffler Mounting Handbook

Rolling bearings are well-proven precision machine elements for the design of economical and reliable bearing arrangements, which offer high operational security. In order that these products can function correctly and achieve the envisaged operating life without detrimental effect, they must be handled with care.



The Schaeffler Mounting Handbook MH 1 gives comprehensive information about the correct storage, mounting, dismounting and maintenance of rotary rolling bearings ► <https://www.schaeffler.de/std/1D53>. It also provides information which should be observed by the designer, in relation to the mounting, dismounting and maintenance of bearings, in the original design of the bearing position. This book is available from Schaeffler on request.



3.18 Legal notice regarding data freshness

The further development of products may also result in technical changes to catalogue products

Of central interest to Schaeffler is the further development and optimisation of its products and the satisfaction of its customers. In order that you, as the customer, can keep yourself optimally informed about the progress that is being made here and with regard to the current technical status of the products, we publish any product changes which differ from the printed version in our electronic product catalogue.



We therefore reserve the right to make changes to the data and illustrations in this catalogue. This catalogue reflects the status at the time of printing. More recent publications released by us (as printed or digital media) will automatically precede this catalogue if they involve the same subject. Therefore, please always use our electronic product catalogue to check whether more up-to-date information or modification notices exist for your desired product.

Link to electronic product catalogue



The following link will take you to the Schaeffler electronic product catalogue: ► <https://medias.schaeffler.com>.

3.19 Further information



In addition to the data in this chapter, the following chapters in Technical principles must also be observed in the design of bearing arrangements:

- Determining the bearing size ▶ 34
- Rigidity ▶ 54
- Friction and increases in temperature ▶ 56
- Speeds ▶ 64
- Bearing data ▶ 97
- Lubrication ▶ 70
- Sealing ▶ 182
- Design of bearing arrangements ▶ 139
- Mounting and dismounting ▶ 191.





Single row full complement cylindrical roller bearings
Semi-locating bearings

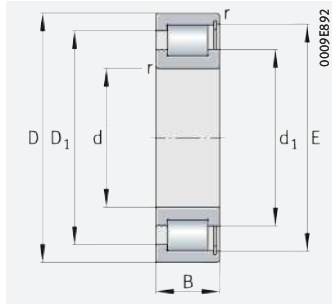

SL1829, SL1830, SL1822

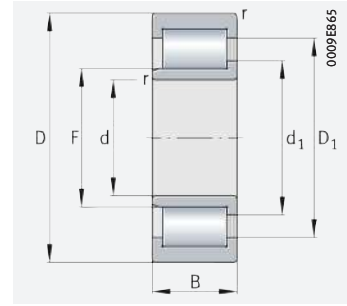

SL1923

d = 20 – 65 mm

Main dimensions			Basic load ratings		Fatigue limit load	Limiting speed	Speed rating	Mass	Designation
d	D	B	dyn. C _r	stat. C _{0r}	C _{ur}	n _G	n _{Dr}	m	▶ 507 3.12 ▶ 507 3.13 X-life ▶ 500
			N	N	N	min ⁻¹	min ⁻¹	≈ kg	
20	42	16	30 500	26 000	4 450	11 400	7 500	0,11	SL183004-XL
	47	18	45 500	37 000	6 100	10 400	6 500	0,16	SL182204-XL
25	47	16	35 000	32 000	5 500	9 500	6 000	0,12	SL183005-XL
	52	18	51 000	44 500	7 400	9 000	5 500	0,18	SL182205-XL
	62	24	73 000	59 000	9 400	8 100	4 800	0,37	SL192305-XL
30	55	19	45 000	42 000	7 500	8 100	5 600	0,2	SL183006-XL
	62	20	70 000	64 000	10 200	7 400	4 550	0,3	SL182206-XL
	72	27	100 000	87 000	14 500	6 800	4 050	0,56	SL192306-XL
35	62	20	55 000	53 000	9 400	7 100	4 950	0,26	SL183007-XL
	72	23	88 000	78 000	12 700	6 400	4 250	0,44	SL182207-XL
	80	31	126 000	110 000	20 200	5 800	3 600	0,74	SL192307-XL
40	68	21	66 000	67 000	11 200	6 300	4 350	0,31	SL183008-XL
	80	23	97 000	91 000	14 900	5 600	3 650	0,55	SL182208-XL
	90	33	170 000	153 000	28 500	5 000	3 050	1,01	SL192308-XL
45	75	23	70 000	74 000	12 500	5 800	4 200	0,4	SL183009-XL
	85	23	101 000	98 000	16 000	5 300	3 450	0,59	SL182209-XL
	100	36	181 000	164 000	30 500	4 600	3 000	1,37	SL192309-XL
50	80	23	88 000	94 000	15 100	5 300	3 700	0,43	SL183010-XL
	90	23	109 000	111 000	18 100	4 750	3 000	0,64	SL182210-XL
	110	40	232 000	215 000	40 500	4 200	2 800	1,81	SL192310-XL
55	90	26	120 000	136 000	22 600	4 550	3 100	0,64	SL183011-XL
	100	25	140 000	148 000	25 000	4 350	2 700	0,87	SL182211-XL
	120	43	270 000	250 000	48 000	3 750	2 550	2,28	SL192311-XL
60	85	16	63 000	76 000	13 700	4 700	2 900	0,29	SL182912-XL
	95	26	123 000	143 000	23 700	4 350	3 000	0,69	SL183012-XL
	110	28	169 000	176 000	32 500	3 900	2 550	1,18	SL182212-XL
	130	46	285 000	275 000	53 000	3 500	2 480	2,88	SL192312-XL
65	90	16	67 000	84 000	15 100	4 250	2 550	0,31	SL182913-XL
	100	26	130 000	157 000	26 000	4 000	2 700	0,73	SL183013-XL
	120	31	198 000	210 000	39 000	3 650	2 480	1,57	SL182213-XL
	140	48	350 000	345 000	66 000	3 200	2 180	3,52	SL192313-XL

medias ▶ <https://www.schaeffler.de/std/1DFB>

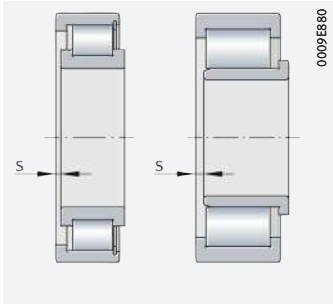

Axial displacement "s"

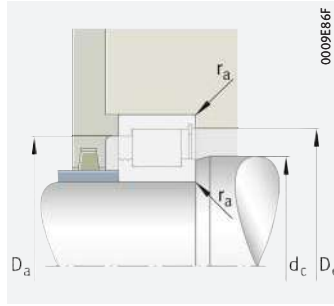

Mounting dimensions for SL1829, SL1830, SL1822

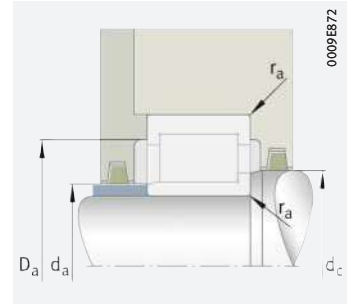

Mounting dimensions for SL1923

Dimensions

d	r	s	F	d ₁	D ₁	E
	min.			≈	≈	
20	0,6	1,5	–	28,8	32,8	36,8
	1	1	–	30,3	36,9	41,5
25	0,6	1,5	–	34,6	38,5	42,5
	1	1	–	35,5	41,9	46,5
	1,1	2	31,7	36,7	47,5	–
30	1	2	–	40	45,4	49,6
	1	1	–	42	50,6	55,2
	1,1	2	38,3	43,5	56	–
35	1	2	–	44,9	51,3	55,5
	1,1	1	–	47	59,3	64
	1,5	2	44,7	50,7	65,8	–
40	1	2	–	50,5	57,1	61,7
	1,1	1	–	54	66,3	70,9
	1,5	2	51,1	57,5	75,2	–
45	1	2	–	55,3	62,2	66,9
	1,1	1	–	57,5	69,8	74,4
	1,5	3	56,1	62,5	80,3	–
50	1	2	–	59,1	67,7	72,3
	1,1	1	–	64,4	76,7	81,4
	2	3	60,7	68,3	89,7	–
55	1,1	2	–	68,5	78,8	83,5
	1,5	1	–	70	84,1	88,8
	2	3	67,1	75,5	99,3	–
60	1	1	–	69	74,4	78,6
	1,1	2	–	71,7	82,1	86,7
	1,5	1,5	–	76,8	93,9	99,2
	2,1	3	73,6	82	105,8	–
65	1	1	–	75,7	81	85,2
	1,1	2	–	78,1	88,4	93,1
	1,5	1,5	–	82,3	100,7	106,3
	2,1	3,5	80,7	90	116,5	–

Mounting dimensions

d _a	d _c	D _a	D _e	r _a
				max.
–	28,5	32,5	36,5	0,6
–	30	36,5	41	1
–	34,5	38,5	42,5	0,6
–	35,5	41,5	46,5	1
31,5	36,5	47,5	–	1,1
–	40	45	49,5	1
–	42	50,5	55	1
38	43,5	56	–	1,1
–	44,5	51	55,5	1
–	47	59	63,5	1,1
44,5	50,5	65,5	–	1,5
–	50,5	57	61,5	1
–	54	66	70,5	1,1
51	57,5	75	–	1,5
–	55	62	66,5	1
–	57,5	69,5	74	1,1
56	62,5	80	–	1,5
–	59	67,5	72	1
–	64	76,5	81	1,1
60,5	68	89,5	–	2
–	68,5	78,5	83,5	1,1
–	70	84	88,5	1,5
67	75,5	99	–	2
–	69	74	78,5	1
–	71,5	82	86,5	1,1
–	76,5	93,5	99	1,5
73,5	82	105,5	–	2,1
–	75,5	81	85	1
–	78	88	93	1,1
–	82	100,5	106	1,5
80,5	90	116,5	–	2,1



Single row full complement cylindrical roller bearings

Semi-locating bearings

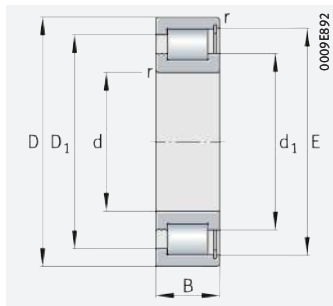

SL1829, SL1830, SL1822

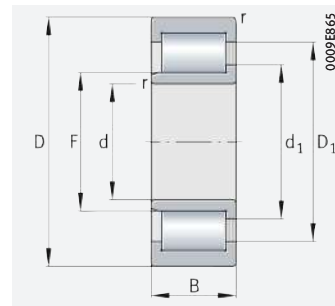

SL1923

d = 70 – 110 mm

Main dimensions			Basic load ratings		Fatigue limit load	Limiting speed	Speed rating	Mass	Designation
d	D	B	dyn. C _r	stat. C _{0r}	C _{ur}	n _G	n _{gr}	m	▶507 3.12 ▶507 3.13 X-life ▶500
			N	N	N	min ⁻¹	min ⁻¹	≈ kg	
70	100	19	88 000	111 000	18 800	3 950	2 550	0,49	SL182914-XL
	110	30	153 000	174 000	29 500	3 750	2 800	1,02	SL183014-XL
	125	31	181 000	223 000	33 500	3 450	2 340	1,66	SL182214
	150	51	385 000	385 000	72 000	3 050	2 170	4,33	SL192314-XL
75	105	19	91 000	119 000	20 100	3 700	2 370	0,52	SL182915-XL
	115	30	162 000	192 000	32 500	3 450	2 490	1,06	SL183015-XL
	130	31	187 000	236 000	35 500	3 250	2 210	1,75	SL182215
	160	55	460 000	465 000	87 000	2 800	2 000	5,3	SL192315-XL
80	110	19	94 000	126 000	21 400	3 500	2 220	0,55	SL182916-XL
	125	34	170 000	220 000	33 000	3 200	2 470	1,43	SL183016
	140	33	223 000	280 000	41 000	3 000	2 040	2,15	SL182216
	170	58	540 000	560 000	100 000	2 600	1 820	6,32	SL192316-XL
85	120	22	118 000	159 000	25 500	3 300	2 200	0,81	SL182917-XL
	130	34	175 000	231 000	34 000	3 050	2 360	1,51	SL183017
	150	36	255 000	320 000	46 500	2 850	2 000	2,74	SL182217
	180	60	570 000	610 000	107 000	2 410	1 710	7,34	SL192317-XL
90	125	22	122 000	169 000	26 500	3 100	2 050	0,84	SL182918-XL
	140	37	205 000	275 000	40 000	2 850	2 240	1,97	SL183018
	160	40	285 000	365 000	53 000	2 700	1 990	3,48	SL182218
	190	64	620 000	650 000	116 000	2 400	1 760	8,83	SL192318-TB-XL
95	130	22	132 000	177 000	27 500	2 950	1 940	0,86	SL182919-XL
	170	43	330 000	425 000	61 000	2 420	1 780	4,17	SL182219
	200	67	650 000	710 000	124 000	2 240	1 620	10,2	SL192319-TB-XL
100	140	24	152 000	203 000	31 500	2 750	1 870	1,14	SL182920-XL
	150	37	216 000	300 000	43 000	2 600	2 040	2,15	SL183020
	180	46	390 000	510 000	73 000	2 300	1 700	5,13	SL182220
	215	73	790 000	850 000	148 000	2 110	1 490	13	SL192320-TB-XL-BR
110	150	24	155 000	213 000	34 000	2 500	1 710	1,23	SL182922-XL
	170	45	280 000	385 000	55 000	2 350	2 010	3,5	SL183022
	200	53	450 000	580 000	81 000	2 130	1 720	7,24	SL182222
	240	80	950 000	970 000	160 000	1 820	1 270	17	SL192322-TB-XL-BR

medias ▶ <https://www.schaeffler.de/std/1DFC>

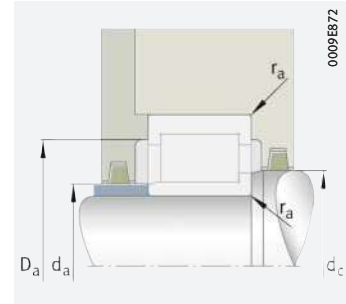
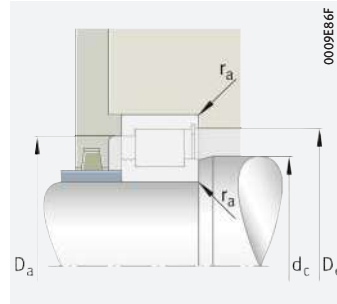
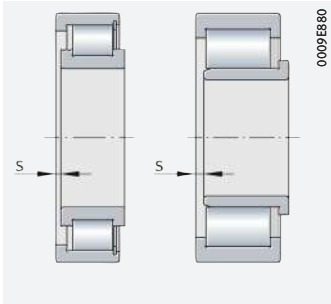

Axial displacement "s"

Mounting dimensions for SL1829, SL1830, SL1822

Mounting dimensions for SL1923

Dimensions							Mounting dimensions				
d	r	s	F	d ₁	D ₁	E	d _a	d _c	D _a	D _e	r _a
	min.			≈	≈						max.
70	1	1	–	81,2	87,8	92,3	–	81	87,5	92	1
	1,1	3	–	81,5	95,6	100,3	–	81,5	95,5	100	1,1
	1,5	1,5	–	87	105,2	111,5	–	87	105	111	1,5
	2,1	3,5	84,1	93,5	121,6	–	84	93,5	121,5	–	2,1
75	1	1	–	86,3	92,8	97,4	–	86	92,5	97	1
	1,1	3	–	89	103,2	107,9	–	89	103	107,5	1,1
	1,5	1,5	–	91,8	110	116,2	–	91,5	110	116	1,5
	2,1	3,5	91,2	101,6	131,5	–	91	101,5	131,5	–	2,1
80	1	1	–	91,4	98	102,5	–	91	98	102,5	1
	1,1	4	–	95	111,7	117,4	–	95	111,5	117	1,1
	2	1,5	–	98,6	119,3	126,3	–	98,5	119	126	2
	2,1	3,5	98,2	109,5	142,1	–	98	109,5	142	–	2,1
85	1,1	1	–	96,4	105	109,6	–	96	105	109,5	1,1
	1,1	4	–	99,4	116,1	122	–	99	116	121,5	1,1
	2	1,5	–	104,4	126,3	133,8	–	104	126	133,5	2
	3	4	107	118,2	150,9	–	107	118	150,5	–	3
90	1,1	1	–	102	110,7	115,8	–	102	110,5	115,5	1,1
	1,5	4	–	106,1	124,5	130,1	–	106	124,5	130	1,5
	2	2,5	–	110,2	133,3	141,2	–	110	133	141	2
	3	4	105,3	117,5	152,5	–	105	117,5	152,5	–	3
95	1,1	1	–	106,7	117	122,3	–	106,5	117	122	1,1
	2,1	2,5	–	122	147,3	156	–	122	147	155,5	2,1
	3	4	114,7	126,6	161,9	–	114,5	126,5	161,5	–	3
100	1,1	1,5	–	113,4	125,7	131	–	113	125,5	130,5	1,1
	1,5	4	–	115,7	134	140,2	–	115,5	134	140	1,5
	2,1	2,5	–	127,5	154,3	163,4	–	127,5	154	163	2,1
	3	4	119,3	132,7	172,8	–	119	132,5	172,5	–	3
110	1,1	1,5	–	124	136,2	141,5	–	124	136	141,5	1,1
	2	5,5	–	127,3	149,3	156,7	–	127	149	156,5	2
	2,1	4	–	137	168	177,6	–	137	168	177,5	2,1
	3	5	134,3	151,1	199,9	–	134	151	199,5	–	3



Single row full complement cylindrical roller bearings

Semi-locating bearings

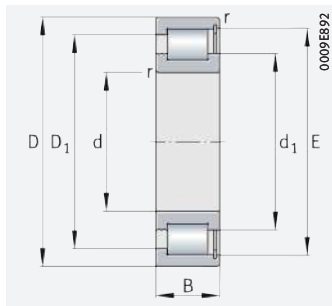

SL1829, SL1830, SL1822

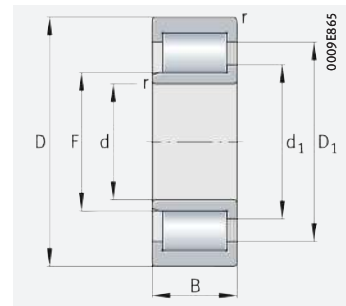

SL1923

d = 120 – 190 mm

Main dimensions			Basic load ratings		Fatigue limit load	Limiting speed	Speed rating	Mass	Designation ▶507 3.12 ▶507 3.13 X-life ▶500
d	D	B	dyn. C _r	stat. C _{0r}	C _{ur}	n _G	n _{Dr}	m	
			N	N	N	min ⁻¹	min ⁻¹	≈ kg	
120	165	27	199 000	285 000	45 500	2 290	1 590	1,73	SL182924-XL
	180	46	295 000	425 000	58 000	2 160	1 840	3,8	SL183024
	215	58	530 000	720 000	99 000	1 930	1 500	9,08	SL182224
	260	86	1 130 000	1 230 000	200 000	1 690	1 120	22,3	SL192324-TB-XL-BR
130	180	30	238 000	350 000	54 000	2 110	1 500	2,33	SL182926-XL
	200	52	425 000	600 000	82 000	1 990	1 660	5,65	SL183026
	230	64	620 000	850 000	113 000	1 790	1 360	11,25	SL182226
	280	93	1 260 000	1 380 000	222 000	1 570	1 040	27,95	SL192326-TB-XL-BR
140	190	30	260 000	375 000	60 000	1 950	1 370	2,42	SL182928-XL
	210	53	450 000	660 000	88 000	1 820	1 470	6,04	SL183028
	250	68	720 000	1 000 000	132 000	1 660	1 230	14,47	SL182228
	300	102	1 410 000	1 570 000	248 000	1 470	970	34,9	SL192328-TB-XL-BR
150	210	36	340 000	480 000	77 000	1 790	1 360	3,77	SL182930-XL
	225	56	475 000	700 000	91 000	1 740	1 430	7,33	SL183030
	270	73	820 000	1 160 000	151 000	1 560	1 130	18,43	SL182230
	320	108	1 490 000	1 900 000	231 000	1 350	840	42,1	SL192330-TB-BR
160	220	36	350 000	510 000	80 000	1 680	1 270	4	SL182932-XL
	240	60	540 000	800 000	103 000	1 600	1 280	8,8	SL183032
	290	80	1 020 000	1 470 000	184 000	1 370	920	23	SL182232
	340	114	1 690 000	2 170 000	240 000	1 250	760	49,7	SL192332-TB-BR
170	230	36	365 000	540 000	84 000	1 590	1 190	4,3	SL182934-XL
	260	67	700 000	1 050 000	133 000	1 480	1 120	12,2	SL183034
	310	86	1 140 000	1 660 000	205 000	1 300	870	28,65	SL182234
	360	120	1 830 000	2 380 000	265 000	1 200	730	59,2	SL192334-TB-BR
180	250	42	455 000	680 000	104 000	1 500	1 150	6,2	SL182936-XL
	280	74	810 000	1 240 000	155 000	1 370	1 020	16,1	SL183036
	320	86	1 180 000	1 760 000	214 000	1 230	800	29,8	SL182236
	380	126	1 940 000	2 600 000	280 000	1 120	670	69,1	SL192336-TB-BR
190	260	42	510 000	770 000	117 000	1 420	1 030	6,5	SL182938-XL
	290	75	830 000	1 300 000	160 000	1 320	970	17	SL183038
	340	92	1 300 000	1 900 000	229 000	1 170	770	35,65	SL182238
	400	132	2 220 000	2 950 000	315 000	1 090	630	80,3	SL192338-TB-BR

medias ▶ <https://www.schaeffler.de/std/1DFD>

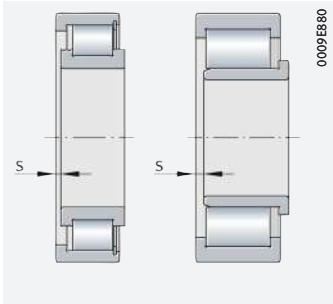

Axial displacement "s"

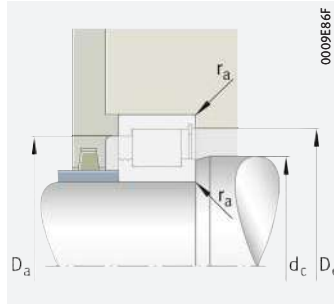

Mounting dimensions for SL1829, SL1830, SL1822

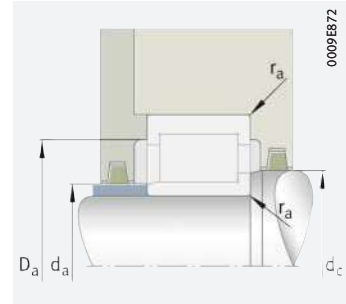

Mounting dimensions for SL1923

Dimensions

d	r	s	F	d ₁	D ₁	E
	min.			≈	≈	
120	1,1	1,5	–	134,8	149	154,3
	2	5,5	–	138,8	160,7	168,2
	2,1	4	–	150,7	183	192,9
	3	5	147,4	164,2	213,1	–
130	1,5	2	–	146	161,1	167,2
	2	5,5	–	148,6	175,5	184,4
	3	5	–	162,3	197	207,8
	4	5	157,9	176	227,9	–
140	1,5	2	–	157	174	180
	2	5,5	–	162,2	189,5	198,4
	3	5	–	173,9	211,1	222,6
	4	7	168,4	187,8	243,4	–
150	2	2,5	–	169	189,6	196,8
	2,1	7	–	170	198	207,5
	3	6	–	185,5	225,2	237,4
	4	7	182,5	203,3	263,5	–
160	2	2,5	–	179,7	200,5	207,6
	2,1	7	–	184,8	215,8	225,5
	3	6	–	208,7	253,4	267,1
	4	7	196,4	219	284,4	–
170	2	2,5	–	190,6	211,3	218,5
	2,1	7	–	198,1	232,7	243,6
	4	7	–	220,3	267,4	281,9
	4	7	203,6	226,6	295	–
180	2	2,5	–	200,7	224	231,9
	2,1	7	–	212,2	249,4	261
	4	7	–	232,4	279,5	294
	4	7	221,6	245	312,9	–
190	2	2	–	211,5	238,5	244,2
	2,1	9	–	221,8	259	270,6
	4	9	–	243,5	295,5	311,5
	5	7	224,4	250	326,8	–

Mounting dimensions

d _a	d _c	D _a	D _e	r _a
				max.
–	134,5	149	154	1,1
–	138,5	160,5	168	2
–	150,5	183	192,5	2,1
147	164	213	–	3
–	146	161	167	1,5
–	148,5	175,5	184	2
–	162	197	207,5	3
157,5	176	227,5	–	4
–	157	174	180	1,5
–	162	189,5	198	2
–	173,5	211	222,5	3
168	187,5	243	–	4
–	169	189,5	196,5	2
–	170	198	207	2,1
–	185,5	225	237	3
182	203	263,5	–	4
–	179,5	200,5	207,5	2
–	184,5	215,5	225	2,1
–	208,5	253	267	3
196	219	284	–	4
–	190,5	211	218	2
–	198	232,5	243,5	2,1
–	220	267	281,5	4
203,5	226,5	295	–	4
–	200,5	224	231,5	2
–	212	249	261	2,1
–	232	279,5	294	4
221,5	245	312,5	–	4
–	211,5	238,5	244	2
–	221,5	259	270,5	2,1
–	243,5	295,5	311,5	4
224	250	326,5	–	5





Single row full complement cylindrical roller bearings

Semi-locating bearings

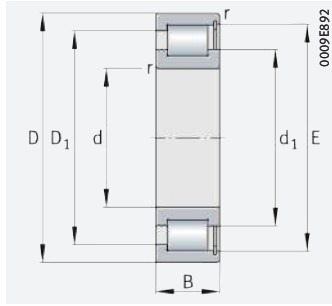

SL1818, SL1829, SL1830, SL1822

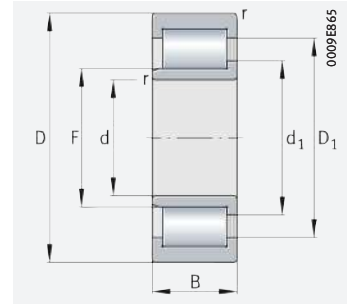

SL1923

d = 200 – 360 mm

Main dimensions			Basic load ratings		Fatigue limit load	Limiting speed	Speed rating	Mass	Designation
d	D	B	dyn. C _r	stat. C _{0r}	C _{ur}	n _G	n _{∅r}	m	▶ 507 3.12 ▶ 507 3.13 X-life ▶ 500
			N	N	N	min ⁻¹	min ⁻¹	≈ kg	
200	250	24	178 000	320 000	33 500	1 420	1 040	2,57	SL181840
	280	48	610 000	940 000	140 000	1 320	950	9,1	SL182940-XL
	310	82	950 000	1 510 000	184 000	1 230	890	21,8	SL183040
	360	98	1 410 000	2 010 000	242 000	1 150	770	43,12	SL182240
	420	138	2 470 000	3 300 000	345 000	1 020	570	92,1	SL192340-TB-BR
220	270	24	187 000	350 000	36 000	1 290	940	2,8	SL181844
	300	48	650 000	1 030 000	150 000	1 210	840	9,9	SL182944-XL
	340	90	1 150 000	1 820 000	215 000	1 140	800	28,4	SL183044
	460	145	2 650 000	3 450 000	355 000	910	520	111,2	SL192344-TB-BR
240	300	28	265 000	490 000	54 000	1 160	870	4,29	SL181848-E
	320	48	600 000	1 120 000	130 000	1 120	750	10,6	SL182948
	360	92	1 210 000	1 990 000	230 000	1 040	720	30,9	SL183048
	500	155	2 900 000	3 800 000	385 000	860	500	142,3	SL192348-TB-BR
260	320	28	275 000	530 000	57 000	1 080	790	4,61	SL181852-E
	360	60	780 000	1 450 000	166 000	1 020	690	18,5	SL182952
	400	104	1 600 000	2 500 000	285 000	940	620	44,5	SL183052-TB
	540	165	3 550 000	4 700 000	460 000	760	410	173,2	SL192352-TB-BR
280	350	33	355 000	670 000	73 000	990	730	6,89	SL181856-E
	380	60	910 000	1 710 000	190 000	940	590	19,7	SL182956-TB
	420	106	1 650 000	2 650 000	295 000	900	590	48	SL183056-TB
300	380	38	455 000	840 000	90 000	920	680	9,79	SL181860-E
	420	72	1 170 000	2 200 000	242 000	870	540	31,2	SL182960-TB
	460	118	2 020 000	3 300 000	330 000	800	500	66,6	SL183060-TB
320	400	38	470 000	900 000	94 000	870	620	10,36	SL181864-E
	440	72	1 210 000	2 340 000	255 000	820	495	32,9	SL182964-TB
	480	121	2 080 000	3 450 000	345 000	770	480	71,7	SL183064-TB
340	420	38	485 000	960 000	98 000	810	570	10,93	SL181868-E
	460	72	1 250 000	2 470 000	265 000	770	460	34,7	SL182968-TB
	520	133	2 490 000	4 150 000	395 000	710	430	95,8	SL183068-TB
360	440	38	500 000	1 010 000	102 000	770	530	11,49	SL181872-E
	480	72	1 280 000	2 600 000	275 000	730	430	36,4	SL182972-TB
	540	134	2 550 000	4 350 000	410 000	680	405	101	SL183072-TB

medias ▶ <https://www.schaeffler.de/std/1DFE>

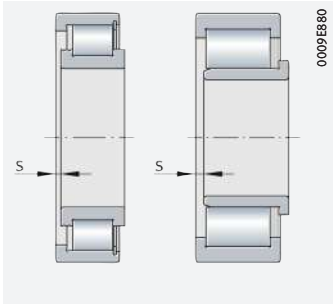

Axial displacement "s"

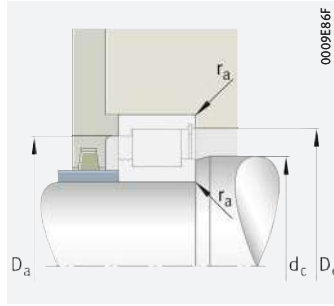

Mounting dimensions
for SL1818, SL1829, SL1830, SL1822

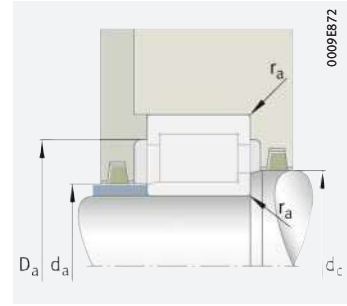

Mounting dimensions
for SL1923

Dimensions							Mounting dimensions				
d	r	s	F	d ₁	D ₁	E	d _a	d _c	D _a	D _e	r _a
	min.			≈	≈						max.
200	1,5	2	–	216,6	231,6	237,6	–	216,5	231,5	237,5	1,5
	2,1	3	–	225,5	252,4	261,6	–	225,5	252	261,5	2,1
	2,1	9	–	236,6	276,2	288,6	–	236,5	276	288,5	2,1
	4	9	–	246,6	302,4	319,4	–	246,5	302	319	4
	5	7	238,5	265,7	347,2	–	238	265,5	347	–	5
220	1,5	2	–	237,3	252,3	258,5	–	237	252	258,5	1,5
	2,1	3	–	246,3	273,2	282,5	–	246	273	282	2,1
	3	9	–	254,6	299,2	312	–	254,5	299	312	3
	5	7	266,7	297	388,3	–	266,5	297	388	–	5
240	2	2	–	260,5	281	287,5	–	260,5	281	287,5	2
	2,1	3	–	267,5	294,4	303,7	–	267,5	294	303,5	2,1
	3	11	–	277,5	322,1	336	–	277,5	322	336	3
	5	10	280,6	312,5	408,5	–	280,5	312,5	408,5	–	5
260	2	2	–	281	301,5	308	–	281	301,5	308	2
	2,1	5	–	291,5	323,4	333,7	–	291,5	323	333,5	2,1
	4	11	–	304	358,4	376	–	304	358	375,5	4
	6	10	315,6	351,6	459,6	–	315,5	351,5	459,5	–	6
280	2	2,5	–	304	327	335	–	304	327	335	2
	2,1	3,5	–	314	348,5	359,5	–	314	348,5	359,5	2,1
	4	11	–	319,5	372,9	390,3	–	319,5	372,5	390	4
300	2,1	3	–	323,5	350,5	360	–	323,5	350,5	360	2,1
	3	5	–	338	376,9	389,5	–	338	376,5	389	3
	4	14	–	353,6	415,6	434,9	–	353,5	415,5	434,5	4
320	2,1	3	–	344,5	371,5	381	–	344,5	371,5	381	2,1
	3	5	–	358,5	397,4	409,9	–	358,5	397	409,5	3
	4	14	–	369,5	430,1	449,5	–	369,5	430	449,5	4
340	2,1	3	–	365,5	392,5	402,2	–	365,5	392,5	402	2,1
	3	5	–	379	418,7	430,2	–	379	418,5	430	3
	5	16	–	396,1	463,9	485,7	–	396	463,5	485,5	5
360	2,1	3	–	387	413,5	423,5	–	387	413,5	423,5	2,1
	3	5	–	399,5	438,6	450,6	–	399,5	438,5	450,5	3
	5	16	–	414	481,6	503,5	–	414	481,5	503	5





Single row full complement cylindrical roller bearings

Semi-locating bearings

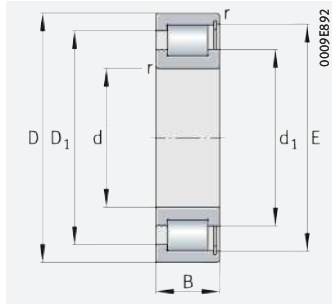

SL1818, SL1829, SL1830

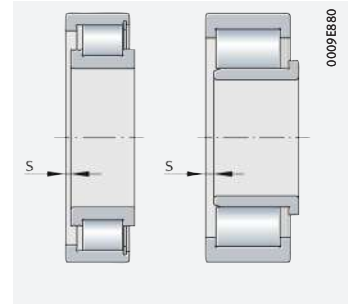

Axial displacement "s"

d = 380 – 500 mm

Main dimensions			Basic load ratings		Fatigue limit load	Limiting speed	Speed rating	Mass	Designation
d	D	B	dyn. C _r N	stat. C _{0r} N	C _{ur} N	n _G min ⁻¹	n _{∅r} min ⁻¹	m ≈ kg	▶ 507 3.12 ▶ 507 3.13
380	480	46	650 000	1 290 000	131 000	710	490	18,87	SL181876-E
	520	82	1 660 000	3 300 000	340 000	680	380	52,1	SL182976-TB
	560	135	2 600 000	4 450 000	425 000	660	390	106	SL183076-TB
400	500	46	660 000	1 340 000	135 000	680	470	19,81	SL181880-E
	540	82	1 710 000	3 500 000	355 000	650	350	54,3	SL182980-TB
	600	148	3 050 000	5 400 000	510 000	610	345	140	SL183080-TB
420	520	46	680 000	1 420 000	141 000	650	430	20,6	SL181884-E
	560	82	1 730 000	3 600 000	365 000	630	340	56,9	SL182984-TB
440	540	46	700 000	1 470 000	145 000	620	415	21,54	SL181888-E
	600	95	2 090 000	4 100 000	410 000	590	325	78,1	SL182988-TB
460	580	56	940 000	1 890 000	186 000	580	385	33,21	SL181892-E-TB
	620	95	2 130 000	4 250 000	420 000	570	310	81,1	SL182992-TB
480	600	56	960 000	1 970 000	192 000	560	365	34,53	SL181896-E-TB
	650	100	2 390 000	4 800 000	470 000	530	280	94,7	SL182996-TB
500	620	56	980 000	2 050 000	197 000	540	345	35,73	SL1818/500-E-TB
	670	100	2 430 000	4 950 000	480 000	520	270	98,3	SL1829/500-TB

medias ▶ <https://www.schaeffler.de/std/1DFF>

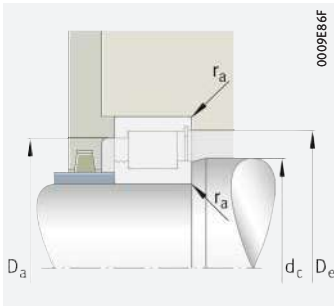

Mounting dimensions
for SL1818, SL1829, SL1830

Dimensions						Mounting dimensions				
d	r	s	d ₁	D ₁	E	d _a	d _c	D _a	D _e	r _a
	min.		≈	≈						max.
380	2,1	4	415,5	448	459	–	415,5	448	459	2,1
	4	5	426	472,1	486,7	–	426	472	486,5	4
	5	16	431,7	499,5	521,3	–	431,5	499,5	521	5
400	2,1	4	432	464,5	475,5	–	432	464,5	475,5	2,1
	4	5	450	496,1	510,9	–	450	496	510,5	4
	5	18	462,5	535,1	558,5	–	462,5	535	558,5	5
420	2,1	4	457	489,5	500	–	457	489,5	500	2,1
	4	5	462	509	523	–	462	509	522,5	4
440	2,1	4	473,5	506	517	–	473,5	506	517	2,1
	4	7	490	544,6	562	–	490	544,5	562	4
460	3	5	501,5	540	554	–	501,5	540	554	3
	4	7	504	559,6	576,3	–	504	559,5	576	4
480	3	5	522	560	574,5	–	522	560	574,5	3
	5	7	538	596,6	614,8	–	538	596,5	614,5	5
500	3	5	542	580,5	594,5	–	542	580,5	594,5	3
	5	7	553	612,7	630	–	553	612,5	630	5



4 Double row full complement cylindrical roller bearings



Double row full complement cylindrical roller bearings are suitable where:

- bearing arrangements are subjected to particularly high radial loads ▶ 528 | 4.2
- not only particularly high radial forces but also high axial loads from one or both directions must be supported by the bearing position (semi-locating or locating bearing function) ▶ 528 | 4.2
- bearing arrangements must have very high rigidity
- Axial displacements of the shaft relative to the housing must be compensated without constraint in the bearing (in the case of bearings with a non-locating or semi-locating bearing function) ▶ 524 | 4.1
- very high radial loads occur at lower speeds, i.e. the bearings do not need to achieve speeds as high as those of cylindrical roller bearings with cage ▶ 531 | 4.6 and ▶ 542 | 4.6
- space-saving designs are required despite very high load
- the bearings should be separable for easier mounting (bearings with non-locating bearing function) ▶ 524 | 4.1 and ▶ 540 | 4.17.

For an overview of other product-specific features, see the Matrix for bearing preselection ▶ 410.

1
Cylindrical roller bearing with cage/single row full complement bearing, double row full complement bearing, comparison of speed and load carrying capacity

C_r = basic dynamic load rating
 n_G = limiting speed

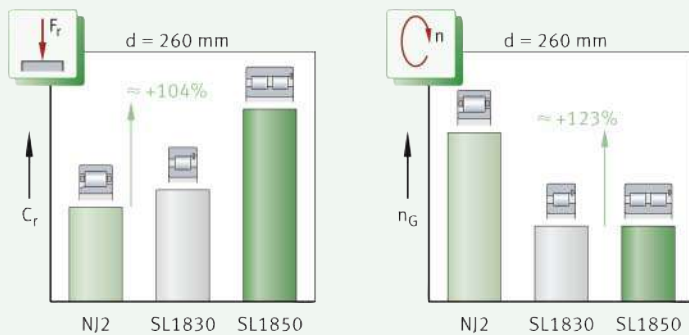

4.1 Bearing design

Design variants

The standard range of double row full complement cylindrical roller bearings comprises:

- series SL0248 and SL0249 (non-locating bearings) ▶ 525 | 4.2
- series SL1850 (semi-locating bearings) ▶ 526 | 4.3
- series SL0148 and SL0149 (locating bearings) ▶ 526 | 4.4
- series SL0450 and SL04 (cylindrical roller bearings with annular slots – rope sheave bearings) ▶ 527 | 4.5
- X-life bearings ▶ 527.



In addition to the bearings described here, Schaeffler supplies double row full complement cylindrical roller bearings in other types, series and dimensions. These products are described in some cases in special publications. If necessary, please contact Schaeffler. Larger catalogue bearings ► [GL 1](#).

Key features

Bearings of basic design – standard range

Double row full complement cylindrical roller bearings are part of the group of radial roller bearings. These bearings comprise solid outer rings, inner rings and full complement rolling element sets. Due to the absence of a cage, the bearing can accommodate the largest possible number of rolling elements. The rollers have profiled ends, i.e. they have a slight lateral curvature towards the ends. This modified line contact between the rolling elements and raceways prevents damaging edge stresses ► [413](#) | [2](#). Bearings in the standard range differ essentially in the arrangement of the ribs on the inner ring and outer ring. Depending on the design, they are used as non-locating bearings, semi-locating bearings or locating bearings.

Bearings with non-locating bearing function

Series SL0248, SL0249

In bearings of these series, the inner ring has three rigid ribs, while the outer ring is without ribs ► [525](#) | [2](#). As a result, axial displacements of the shaft relative to the housing can be compensated within certain limits. During rotational motion, length compensation occurs without constraint in the bearing between the rollers and the raceway without ribs and is therefore practically free from friction. The maximum axial displacement s is given in the product tables. The bearings are used as non-locating bearings, i.e. they cannot guide the shaft axially in either direction ► [528](#) | [4.2](#). The series SL0248 and SL0249 are not self-retaining (the outer ring without ribs can be removed from the bearing). As a result, the bearing parts (the inner ring with the rolling element set and the outer ring) can be mounted separately from each other. This gives easier mounting of the bearings ► [540](#) | [4.17](#).



According to DIN 5412-9:1982, which has now been withdrawn, the bearings have the following designation:

- SL0248: NNCL48..V
- SL0249: NNCL49..V



The bearings are held together in handling and mounting by a transport and mounting retaining device on the outer ring ► [525](#) | [2](#). This retaining device remains in the bearing even after mounting and must not be subjected to axial load.



Double row full complement cylindrical roller bearing – non-locating bearing

F_r = radial load

① Transport and mounting retaining device

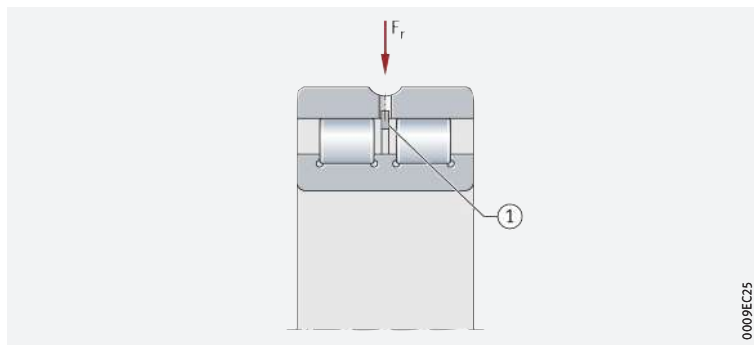

Series SL1850

Bearings with semi-locating bearing function

Bearings of series SL1850 (dimension series 50) have three rigid ribs on the inner ring and one rigid rib on the outer ring ► [526](#) | [3](#). In these cylindrical roller bearings, axial displacements of the shaft relative to the housing are possible in one direction only. The maximum axial displacement s is given in the product tables ► [542](#) | [3](#). The bearings are used as semi-locating bearings, i.e. they can guide the shaft axially in one direction ► [528](#) | [4.2](#).



The bearings are held together in handling and mounting by a transport and mounting retaining device on the outer ring ► 526 | 3. This retaining device remains in the bearing even after mounting and must not be subjected to axial load.



Double row full complement cylindrical roller bearing – semi-locating bearing

F_r = radial load

F_a = axial load

① Transport and mounting retaining device

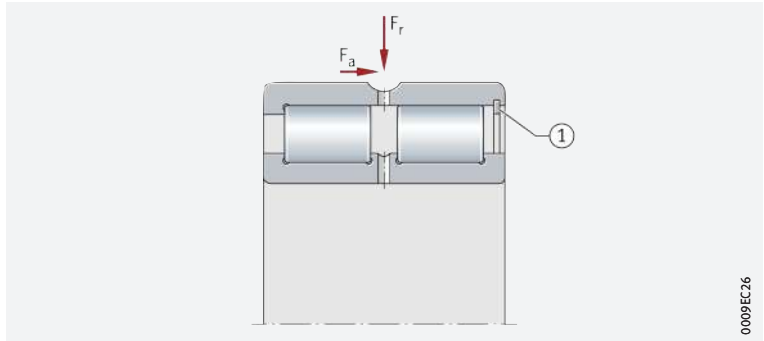

Series SL0148, SL0149

Bearings with locating bearing function

In these bearings, the inner ring has three rigid ribs and the outer ring has two rigid ribs ► 526 | 4. Axial displacements between the shaft and housing are not possible. The bearings are used as locating bearings, i.e. they can guide the shaft axially in both directions ► 528 | 4.2.



According to DIN 5412-9:1982, which has now been withdrawn, the bearings have the following designation:

■ SL0148: NNC48..V

■ SL0149: NNC49..V



The split outer ring is held together by a transport and mounting retaining device ► 526 | 4. This retaining device remains in the bearing even after mounting and must not be subjected to axial load.



Double row full complement cylindrical roller bearing – locating bearing

F_r = radial load

F_a = axial load

① Retaining ring

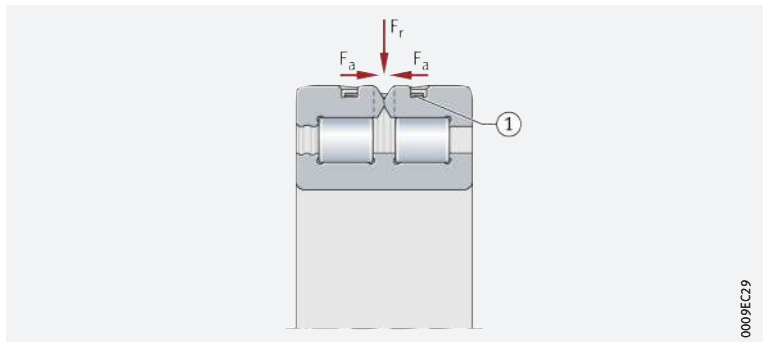

Series SL0450..-PP and SL04..-PP – cylindrical roller bearings with annular slots

Bearings with locating bearing function, particularly suitable for the support of rope sheaves

These bearings comprise solid outer rings without ribs, inner rings with three ribs, rib-guided rolling element sets and sealing rings ► 527 | 5. The outer rings have annular slots for retaining rings. The inner rings are axially split, 1 mm wider than the outer rings and held together by a sheet metal ring. They are used as locating bearings (but can support only slight axial loads) and are used in preference for the support of rope sheaves.

Light series and dimension series 50

Cylindrical roller bearings with annular slots are available as a light series SL04..-PP and in the dimension series 50 as SL0450..-PP. The latter has a higher load carrying capacity than the light series ► 550 | 5.



Extensive information on rope sheave bearing arrangements is given in the Technical Product Information TPI 237. This publication can be requested from Schaeffler.



5
Double row full complement cylindrical roller bearing with annular slots – locating bearing

F_r = radial load

F_a = axial load

- ① Slots in outer ring
- ② Sealing rings
- ③ Sheet metal ring
- ④ Retaining rings
- ⑤ Rope sheave

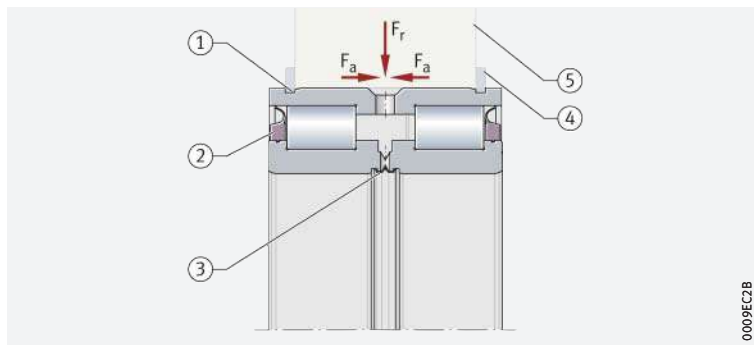

X-life

X-life premium quality

Double row full complement cylindrical roller bearings of series SL1850 are available in many sizes as X-life bearings ▶ 542 | . These bearings exhibit considerably higher performance than comparable standard cylindrical roller bearings. This is achieved, for example, through the modified internal construction, the optimised contact geometry between the rollers and raceways, the better surface quality and the optimised roller guidance and lubricant film formation.

Advantages

Increased customer benefits due to X-life

- These technical enhancements offer a range of advantages, such as:
- a more favourable load distribution in the bearing and thus a higher dynamic load carrying capacity of the bearings
 - a higher fatigue limit load
 - lower heat generation in the bearing
 - lower lubricant consumption and therefore longer maintenance intervals if relubrication is carried out
 - a measurably longer operating life of the bearings
 - high operational security
 - compact, environmentally-friendly bearing arrangements.

Interchangeable with comparable standard bearings

Since X-life cylindrical roller bearings have the same dimensions as the corresponding standard bearings, the latter can be replaced without any problems by the higher-performance X-life bearings. The major advantages of X-life can therefore also be used for existing bearing arrangements with standard bearings.

Lower operating costs, higher machine availability

In conclusion, these advantages improve the overall cost-efficiency of the bearing position significantly and thus bring about a sustainable increase in the efficiency of the machine and equipment.

Suffix XL

X-life cylindrical roller bearings include the suffix XL in the designation ▶ 534 | 4.12 and ▶ 542 | .

Areas of application

Due to their special technical features, double row full complement X-life cylindrical roller bearings are highly suitable, for example, for bearing arrangements in:

- heavy industry (steel production)
- power transmission (gearbox engineering)
- processing machines and construction machinery
- wind turbines (gearbox applications).



X-life indicates a high product performance density and thus a particularly significant benefit to the customer. Further information on X-life ▶ 10.



4.2 Load carrying capacity

☞ *Designed for very high radial loads*

Depending on the type, double row full complement cylindrical roller bearings can support not only very high radial forces but also high axial loads on one or both sides:

- The series SL0248 and SL0249 must only be subjected to radial load
- The series SL1850 can support radial loads as well as axial loads on one side
- The series SL0148 and SL0149 can support radial loads as well as axial loads on both sides
- The series SL0450..-PP and SL04..50-PP can support radial loads and are suitable for the support of moderate axial loads from both directions.

Higher axial load carrying capacity of bearings with toroidal crowned roller end face

☞ *Neither wear nor material fatigue occurs on the rib contact running and roller end faces*

In the case of cylindrical roller bearings with toroidal crowned rollers (TB design), the axial load carrying capacity has been significantly improved with the aid of new calculation and manufacturing methods. A special curvature of the roller end faces facilitates optimum contact conditions between the rollers and ribs ➤ 528 | 6. As a result, the axial contact pressures on the rib are significantly minimised and a lubricant film capable of supporting higher loads is formed. Under standard operating conditions, this completely eliminates wear and fatigue at the rib contact running and roller end faces. In addition, the axial frictional torque is reduced by up to 50%. The bearing temperature during operation is therefore significantly lower. Bearings of toroidal crowned design ➤ 542 | 6.



By agreement, bearings of series SL1850 are available starting from a bore diameter $d = 180$ mm in the TB design.

6
Contact geometry of roller end face/rib face – modified roller end faces

- ① Cylindrical roller with inner ring
- ② Detail (representation not to scale)
- ③ End of roller
- ④ Rib

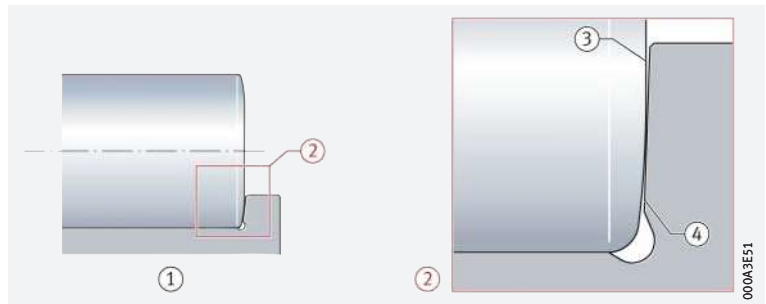

Load ratio F_a/F_r

☞ *Ratio $F_a/F_r \leq 0,4$ or $0,6$*

The bearings can support axial loads on one side by means of the ribs on the inner and outer ring ➤ 529 | 7. In order to ensure problem-free running (tilting of the rollers is prevented), they must always be subjected to radial load at the same time as axial load. The ratio F_a/F_r must not exceed the value 0,4. For bearings with toroidal crowned roller ends (TB design), values up to 0,6 are permissible.



Continuous axial loading without simultaneous radial loading is not permissible.

Influencing factors on the axial load carrying capacity

Permissible axial load

Axial loads are supported by the bearing ribs and the roller end faces ▶ 529 | 7. The axial load carrying capacity of the bearing is therefore essentially dependent on:

- the size of the sliding surfaces between the ribs and the end faces of the rolling elements
- the sliding velocity at the ribs
- the lubrication of the contact surfaces
- tilting of the bearing
- friction.

7
Force flow under axial load – semi-locating bearing SL1850

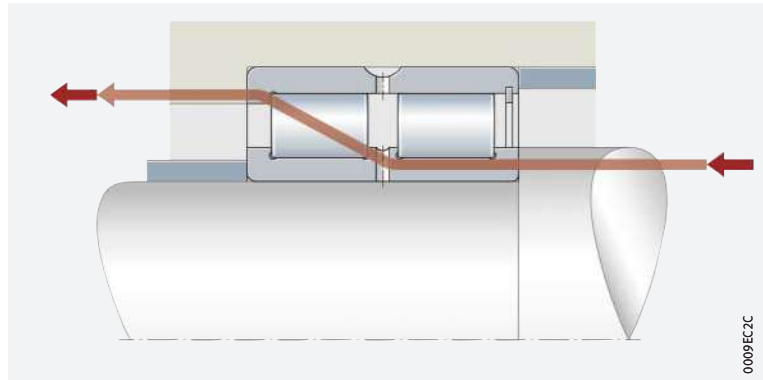

Calculation of permissible axial load – cylindrical rollers with conventional roller ends

Bearings with standard roller ends

The permissible axial load $F_{a\ per}$ can be calculated from the hydrodynamic load carrying capacity of the contact ▶ 529 | 1.

1
Permissible axial load – bearings of standard design

$$F_{a\ per} = k_S \cdot k_B \cdot d_M^{1,54} \cdot n^{-0,6} \leq F_{a\ max}$$

Legend

$F_{a\ per}$	N	Permissible continuous axial load. In order to prevent unacceptably high temperatures in the bearing, $F_{a\ per}$ must not be exceeded
$F_{a\ max}$	N	Maximum continuous axial load in relation to rib fracture. In order to prevent unacceptably high pressures at the contact surfaces, $F_{a\ max}$ must not be exceeded
k_S	–	Factor as a function of lubrication method ▶ 529 1. The factor takes into consideration the lubrication method used for the bearing. The better the lubrication and, in particular, the heat dissipation, the higher the permissible axial load
k_B	–	Factor as a function of bearing series ▶ 530 2
d_M	mm	Mean bearing diameter $d_M = (D + d)/2$ ▶ 542 1
n	min ⁻¹	Operating speed.

1
Factor k_S

Lubrication method	Factor k_S	
	from	up to
Standard greasing, no heat dissipation by the lubricant	1,5	3
Minimal heat dissipation, drip feed oil lubrication, oil mist lubrication, low operating viscosity ($\nu < 0,5 \cdot \nu_1$)	7,5	10
Poor heat dissipation, oil sump lubrication, oil spray lubrication, low oil flow	10	15
Good heat dissipation, recirculating oil lubrication (pressurised oil lubrication)	12	18
Very good heat dissipation, recirculating oil lubrication with oil cooling, high operating viscosity ($\nu > 2 \cdot \nu_1$)	16	24



The precondition for these k_S values is an operating viscosity of the lubricant of at least the reference viscosity ν_1 in accordance with DIN ISO 281:2010.



Doped lubricating oils should be used, such as CLP (DIN 51517) and HLP (DIN 51524) of ISO VG grades 32 to 460, as well as ATF oils (DIN 51502) and transmission oils (DIN 51512) of SAE viscosity grades 75W to 140W.

2
Bearing factor k_B

Series	k_B
SL0148	4,5
SL0149	11
SL1850	17
SL0450	17
SL04	10

Calculation of permissible axial load – cylindrical rollers with toroidal roller ends

For bearings with toroidal roller ends, the permissible axial loads are 50% higher $\blacktriangleright 530 | f1 2$.

2
Permissible axial load – bearings of TB design

$$F_{a\text{ per}} = 1,5 \cdot k_S \cdot k_B \cdot d_M^{1,54} \cdot n^{-0,6} \leq F_{a\text{ max}}$$

Calculation of maximum permissible axial load

For bearings with rollers of the standard or TB design, the maximum permissible axial load $F_{a\text{ max}} \blacktriangleright 530 | f1 3$ is calculated from the rib strength and the security against wear. This must not be exceeded, even if $F_{a\text{ per}}$ gives higher values $\blacktriangleright 530 | f1 4$.

3
Maximum axial load – bearings of standard and TB design

$$F_{a\text{ max}} = 0,075 \cdot k_B \cdot d_M^{2,1}$$

4
Permissible axial load

$$F_{a\text{ per}} \leq F_{a\text{ max}}$$

Axial load carrying capacity of cylindrical roller bearings with annular slots (rope sheave bearings)



For cylindrical roller bearings with annular slots in the outer ring, the calculations of $F_{a\text{ per}}$ and $F_{a\text{ max}}$ cannot be used. For the axial load carrying capacity of these bearings, please consult Schaeffler.

4.3 Compensation of angular misalignments



The bearings do not permit any misalignments between the inner and outer ring, i.e. the bearing positions must be well aligned.

4.4 Lubrication

Oil or grease lubrication is possible

The cylindrical roller bearings are not greased. They must be lubricated with oil or grease. The bearings can be lubricated via the end faces of the outer ring as well as via a lubrication groove and lubrication holes in the outer ring.

The bearings have an initial greasing

Cylindrical roller bearings with annular slots (rope sheave bearings)

These bearings are supplied greased and can be relubricated via the outer ring or inner ring. The grease used is a lithium complex soap grease to GA08. Arcanol LOAD150 $\blacktriangleright 70$ is suitable for relubrication. The greases named are highly suitable, due to their good moisture resistance and high load carrying capacity, for applications in rope sheaves at low to moderate speeds.



If there is any uncertainty regarding the suitability of the selected lubricant for the application, please consult Schaeffler or the lubricant manufacturer.

4.5 Sealing

Provide seals in the adjacent construction

The bearings are not sealed, i. e. sealing of the bearing position must be carried out in the adjacent construction. This must reliably prevent:

- moisture and contaminants from entering the bearing
- the egress of lubricant from the bearing.

The bearings are sealed on both sides

Cylindrical roller bearings with annular slots (rope sheave bearings)

In the case of these bearings, the rolling element system is protected against contamination and moisture by polyurethane sealing rings on both sides of the bearing. The seals have low friction and are particularly resistant to climate and temperature. Where environmental conditions are particularly critical, sealing of the bearings can be improved further by means of additional seals, such as V rings, in the adjacent construction.

4.6 Speeds

Limiting speeds and reference speeds in the product tables

Lower speed capacity than bearings with cage

The product tables give two speeds for most bearings:

- the kinematic limiting speed n_G
- the thermal speed rating n_{ϑ} .

Due to the kinematic conditions, full complement cylindrical roller bearings do not achieve the high speeds that are possible when using cylindrical roller bearings with cage.

Limiting speeds



The limiting speed n_G is the kinematically permissible speed of the bearing. Even under favourable mounting and operating conditions, this value should not be exceeded without prior consultation with Schaeffler ► 64.

Reference speeds

$n_{\vartheta r}$ is used to calculate n_{ϑ}

The thermal speed rating $n_{\vartheta r}$ is not an application-oriented speed limit, but is a calculated ancillary value for determining the thermally safe operating speed n_{ϑ} ► 64.

Bearings with contact seals

For bearings with contact seals, no reference speeds are defined in accordance with DIN ISO 15312:2004. As a result, only the limiting speed n_G is given in the product tables for these bearings.

4.7 Noise

The Schaeffler Noise Index (SGI) has been developed as a new feature for comparing the noise level of different bearing types and series. As a result, a noise evaluation of rolling bearings can now be carried out for the first time.

Schaeffler Noise Index

The SGI value is based on the maximum permissible noise level of a bearing in accordance with internal standards, which is calculated on the basis of ISO 15242. In order that different bearing types and series can be compared, the SGI value is plotted against the basic static load rating C_0 .

This permits direct comparisons between bearings with the same load carrying capacity. The upper limit value is given in each of the diagrams. This means that the average noise level of the bearings is lower than illustrated in the diagram.





The Schaeffler Noise Index is an additional performance characteristic in the selection of bearings for noise-sensitive applications. The specific suitability of a bearing for an application in terms of installation space, load carrying capacity or speed limit for example, must be checked independently of this.



The Noise Index is currently available for the main series. Additional series will be updated and introduced in subsequent publications.

Further information:

■ **medias** ► <https://medias.schaeffler.com>.



Schaeffler Noise Index for double row full complement cylindrical roller bearings

SGI = Schaeffler Noise Index

C_0 = basic static load rating

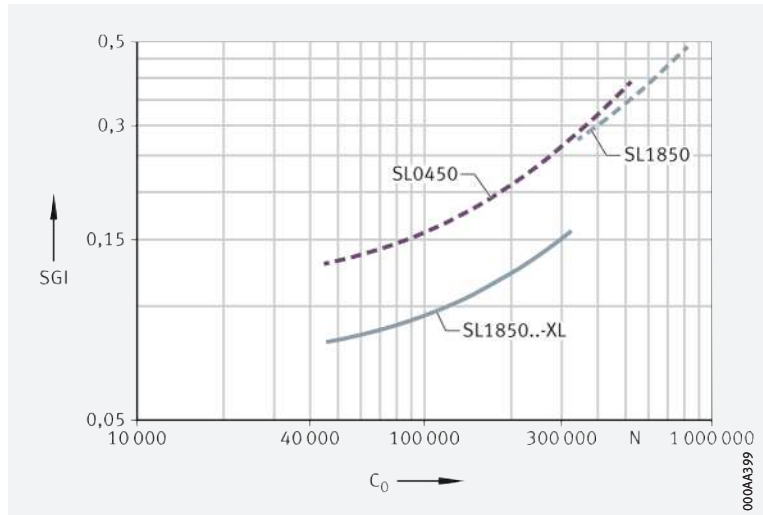

4.8 Temperature range

Limiting values

The operating temperature of the bearings is limited by:

- the dimensional stability of the bearing rings and cylindrical rollers
- the lubricant
- the seals.

Possible operating temperatures of double row cylindrical roller bearings ► 532 | 3.



Permissible temperature ranges

Operating temperature	Open full complement bearings	Rope sheave bearings
	-30 °C to +120 °C	-20 °C to +80 °C, limited by the lubricant, cage material and seal material -40 °C to +80 °C with greasing by means of GA22



In the event of anticipated temperatures which lie outside the stated values, please contact Schaeffler.

4.9 Cages

Full complement cylindrical roller bearings do not have a cage for guidance and separation of the rolling elements. The cylindrical rollers are guided by the ribs on the bearing rings.

4.10 Internal clearance

Radial internal clearance

 The standard is CN

Double row full complement cylindrical roller bearings are manufactured as standard with the radial internal clearance CN (normal) ► 533 |  4. CN is not stated in the designation.



Certain sizes are also available by agreement with the larger internal clearance C3, C4 and C5 ► 533 |  4.



The values for radial internal clearance correspond to DIN 620-4:2004 (ISO 5753-1:2009) ► 533 |  4. They are valid for bearings which are free from load and measurement forces (without elastic deformation).

 4
Radial internal clearance
of double row full complement
cylindrical roller bearings

Nominal bore diameter d mm		Radial internal clearance							
		CN (Group N)		C3 (Group 3)		C4 (Group 4)		C5 (Group 5)	
		μm		μm		μm		μm	
over	incl.	min.	max.	min.	max.	min.	max.	min.	max.
–	24	20	45	35	60	50	75	65	90
24	30	20	45	35	60	50	75	70	95
30	40	25	50	45	70	60	85	80	105
40	50	30	60	50	80	70	100	95	125
50	65	40	70	60	90	80	110	110	140
65	80	40	75	65	100	90	125	130	165
80	100	50	85	75	110	105	140	155	190
100	120	50	90	85	125	125	165	180	220
120	140	60	105	100	145	145	190	200	245
140	160	70	120	115	165	165	215	225	275
160	180	75	125	120	170	170	220	250	300
180	200	90	145	140	195	195	250	275	330
200	225	105	165	160	220	220	280	305	365
225	250	110	175	170	235	235	300	330	395
250	280	125	195	190	260	260	330	370	440
280	315	130	205	200	275	275	350	410	485
315	355	145	225	225	305	305	385	455	535
355	400	190	280	280	370	370	460	510	600



Radial internal clearance of cylindrical roller bearings with annular slots (rope sheave bearings)



The correct radial internal clearance is of decisive importance for the correct function of rope sheaves. The radial internal clearance group is dependent on the material of the rope sheave ► 533 |  5.

 5
Radial internal clearance
of cylindrical roller bearings
with annular slots for the support
of rope sheaves as a function
of the material of adjacent parts –
recommendation

Nominal bore diameter d mm		Material of rope sheave	
		Steel	Plastic
over	incl.	Internal clearance group of bearing	
–	85	CN or C3	C5
85	300	C3	

4.11 Dimensions, tolerances

Dimension standards



The main dimensions of cylindrical roller bearings correspond to ISO 15:2017 (DIN 616:2000).

Chamfer dimensions



The limiting dimensions for chamfer dimensions correspond to DIN 620-6:2004. Overview and limiting values ▶ 135 | 7.11. Nominal value of chamfer dimension ▶ 542 | 8.

Tolerances



The dimensional and running tolerances of the cylindrical roller bearings correspond to the tolerance class Normal in accordance with ISO 492:2014. Tolerance values in accordance with ISO 492 ▶ 122 | 8.

4.12 Suffixes

For a description of the suffixes used in this chapter ▶ 534 | 6, cylindrical roller bearings with annular slots ▶ 534 | 7 and **medias** interchange ▶ <https://www.schaeffler.de/std/1D52>.

6 Suffixes and corresponding descriptions, double row full complement cylindrical roller bearings

Suffix	Description of suffix	
BR	Black oxide coated	Available by agreement
C3	Radial internal clearance C3 (larger than normal)	
C4	Radial internal clearance C4 (larger than C3)	
C5	Radial internal clearance C5 (larger than C4)	
TB	Bearing with increased axial load carrying capacity	Standard, dependent on bore code and bearing series
XL	X-life bearing	

7 Suffixes and corresponding descriptions, cylindrical roller bearings with annular slots (rope sheave bearings)

Suffix	Description of suffix	
C3	Radial internal clearance C3 (larger than normal)	Special design, available by agreement
C4	Radial internal clearance C4 (larger than C3)	
C5	Radial internal clearance C5 (larger than C4)	
D	Improved outer ring profile, with an enlarged load-bearing area and optimised edge transitions	Standard
GA22	Bearing greased with lithium soap grease GA22 for expanded temperature range	Special design, available by agreement
P	Contact seal on one side	
PP	Contact seal on both sides	Standard
RR	Corrosion-resistant design, with Corrotect coating	Special design, available by agreement
2NR	Supplied with two loose-packed retaining rings WRE	
2WR	Supplied with two loose-packed retaining rings WR	
–	Without seals	

4.13 Structure of bearing designation

Examples of composition of bearing designation

The designation of bearings follows a set model. Examples are shown in ▶ 535 | 9 and ▶ 535 | 10. The composition of designations is subject to DIN 623-1 ▶ 102 | 10.

9
Double row full complement cylindrical roller bearing (semi-locating bearing): designation structure

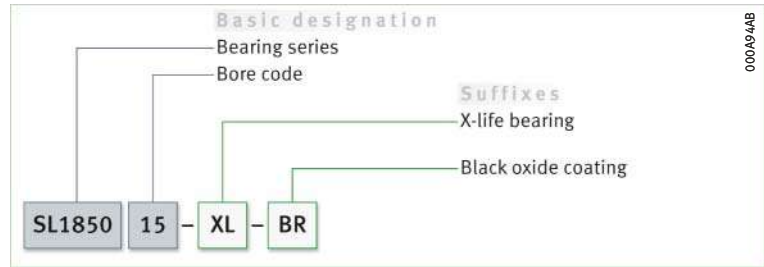

10
Double row full complement cylindrical roller bearing (rope sheave bearing): designation structure

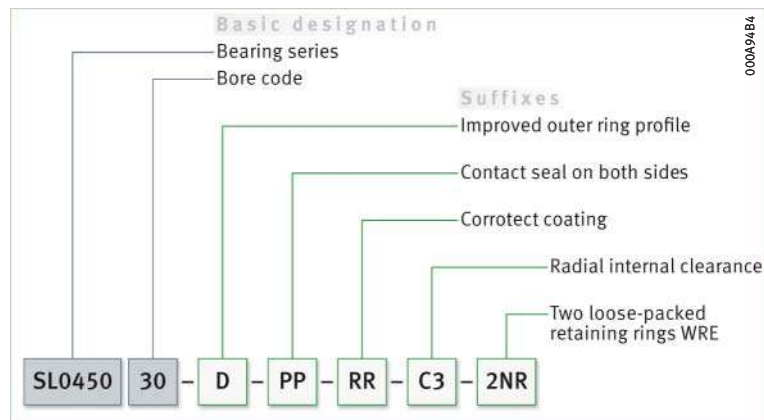

4.14 Dimensioning

$P = F_r$ under purely radial load of constant magnitude and direction

Equivalent dynamic bearing load

The basic rating life equation $L = (C_r/P)^P$ used in the dimensioning of bearings under dynamic load assumes a load of constant magnitude and direction. In radial bearings, this is a purely radial load F_r . If this condition is met, the bearing load F_r is used in the rating life equation for P ($P = F_r$).

Bearings with non-locating bearing function and cylindrical roller bearings with annular slots (rope sheave bearings)

$P = F_r$

Non-locating bearings can only support radial loads, rope sheave bearings only have a small axial load carrying capacity. For these bearings

▶ 535 | 5.

5
Equivalent dynamic load

$$P = F_r$$

Cylindrical roller bearings with semi-locating and locating bearing function

P is a substitute force for combined load and various load cases

If the condition described above is not met, i.e. if, in addition to the radial force F_r , there is also an axial force F_a , a constant radial force must first be determined for the rating life calculation that (in relation to the rating life) represents an equivalent load. This force is known as the equivalent dynamic bearing load P .

$F_a/F_r \leq e$ or $F_a/F_r > e$ The calculation of P is dependent on the load ratio F_a/F_r and the calculation factors e and Y ▶ 536 | f. 6 and ▶ 536 | f. 7.

f. 6
Equivalent dynamic load

$$\frac{F_a}{F_r} \leq e \Rightarrow P = F_r$$

f. 7
Equivalent dynamic load

$$\frac{F_a}{F_r} > e \Rightarrow P = 0,92 \cdot F_r + Y \cdot F_a$$

Legend

P	N	Equivalent dynamic bearing load
F_r	N	Radial load
F_a	N	Axial load
e, Y	-	Factors ▶ 536 8.

f. 8
Factors e and Y

Bearing series	Calculation factors	
	e	Y
SL1850	0,2	0,6
SL0148, SL0149	0,24	0,5

Equivalent static bearing load

$P_0 \geq F_{Or}$ For cylindrical roller bearings subjected to static load ▶ 536 | f. 8.

f. 8
Equivalent static load

$$P_0 = F_{Or}$$

Legend

P_0	N	Equivalent static bearing load
F_{Or}	N	Largest radial load present (maximum load).

Static load safety factor

$S_0 = C_0/P_0$ In addition to the basic rating life L (L_{10h}), it is also always necessary to check the static load safety factor S_0 ▶ 536 | f. 9.

f. 9
Static load safety factor

$$S_0 = \frac{C_0}{P_0}$$

Legend

S_0	-	Static load safety factor
C_0	N	Basic static load rating
P_0	N	Equivalent static bearing load.

4.15 Minimum load

In order to prevent damage due to slippage, a minimum radial load of $P > C_{0r}/60$ is necessary during continuous operation

In order that no slippage occurs between the contact partners, the cylindrical roller bearings must be constantly subjected to a sufficiently high radial load. For continuous operation, experience shows that a minimum radial load of the order of $P > C_{0r}/60$ is thus necessary. In most cases, however, the radial load is already higher than the requisite minimum load due to the weight of the supported parts and the external forces.



If the minimum radial load is lower than indicated above, please consult Schaeffler.

4.16

Design of bearing arrangements

☞ *Support bearing rings over their entire circumference and width*

In order to allow full utilisation of the load carrying capacity of the bearings and achieve the requisite rating life, the bearing rings must be rigidly and uniformly supported by means of contact surfaces over their entire circumference and over the entire width of the raceway. Support can be provided by means of a cylindrical seating surface. The seating and contact surfaces should not be interrupted by grooves, holes or other recesses. The accuracy of mating parts must meet specific requirements ► 538 | 9 to ► 539 | 12.

Radial location

☞ *For secure radial location, tight fits are necessary*

In addition to supporting the rings adequately, the bearings must also be securely located in a radial direction, to prevent creep of the bearing rings on the mating parts under load. This is generally achieved by means of tight fits between the bearing rings and the mating parts. If the rings are not secured adequately or correctly, this can cause severe damage to the bearings and adjacent machine parts. Influencing factors, such as the conditions of rotation, magnitude of the load, internal clearance, temperature conditions, design of the mating parts and the mounting and dismounting options must be taken into consideration in the selection of fits.



If shock type loads occur, tight fits (transition fit or interference fit) are required to prevent the rings from coming loose at any point. Clearance, transition or interference fits ► 150 | 6 and ► 158 | 7.



The following information provided in Technical principles must be taken into consideration in the design of bearing arrangements:

- conditions of rotation ► 145
- tolerance classes for cylindrical shaft seats (radial bearings) ► 147 | 2
- shaft fits ► 150 | 6
- tolerance classes for bearing seats in housings (radial bearings) ► 148 | 4
- housing fits ► 158 | 7.

Radial location of cylindrical roller bearings with annular slots (rope sheave bearings)

☞ *The outer ring must have an interference fit to achieve rigid seating*

The axial loads occurring cannot be securely transmitted by the retaining rings. Transmission of the loads is only possible if sufficient joint pressure is present. Due to the operating conditions present in rope sheave bearing arrangements, an interference fit between the outer ring and rope sheave is absolutely critical in order to achieve correct bearing function and load transmission. The joint pressure must be between $p_{\min} = 2 \text{ N/mm}^2$ and $p_{\max} = 25 \text{ N/mm}^2$. The internal clearance has a considerable influence on bearing function ► 533 | 5.

Axial location

☞ *The bearings must also be securely located in an axial direction*

As a tight fit alone is not normally sufficient to also locate the bearing rings securely on the shaft and in the housing bore in an axial direction, this must usually be achieved by means of an additional axial location or retention method. The axial location of the bearing rings must be matched to the type of bearing arrangement. Shaft and housing shoulders, housing covers, nuts, spacer rings, retaining rings, adapter and withdrawal sleeves etc., are fundamentally suitable; example ► 540 | 12.

Axial location of cylindrical roller bearings with annular slots (rope sheave bearings)

☞ *Axial location is carried out by means of retaining rings*

The annular slots allow axial location of the outer rings using retaining rings ► 538 | 11. Suitable fasteners are WRE rings or rings in accordance with DIN 471. Locating rings are not included in the scope of delivery. The design 2NR is supplied with two retaining rings WRE packed loose. The split inner ring must be axially secured ► 538 | 11. The fasteners must not be subjected to axial load.



Arrangement of several rope sheaves adjacent to each other



If housing tolerances are present or several rope sheaves are arranged adjacent to each other, axial clearance may occur between the inner rings. This must always be prevented by means of design measures. For example, shims are suitable for this purpose.

11
Cylindrical roller bearing with annular slots (rope sheave bearing) – location of outer ring, support of ribs

① Retaining ring

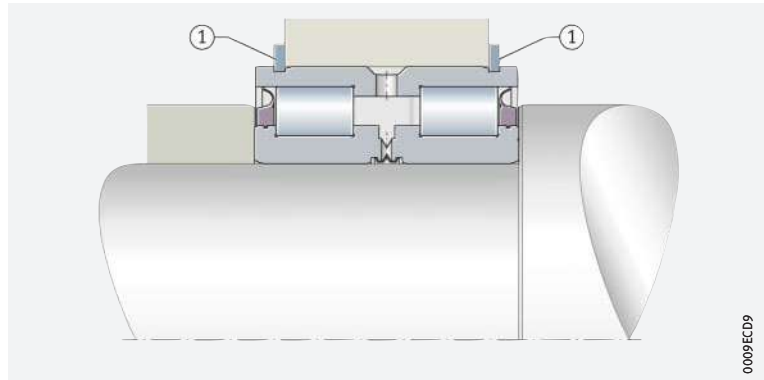

Dimensional, geometrical and running accuracy of cylindrical bearing seats

A minimum of IT6 should be provided for the shaft seat and a minimum of IT7 for the housing seat

The accuracy of the cylindrical bearing seat on the shaft and in the housing should correspond to the accuracy of the bearing used. For cylindrical roller bearings with the tolerance class Normal, the shaft seat should correspond to a minimum of standard tolerance grade IT6 and the housing seat to a minimum of IT7. Guide values for the geometrical and positional tolerances of the bearing seating surfaces > 538 | 9, tolerances t₁ to t₃ in accordance with > 168 | 11. Numerical values for IT grades > 538 | 10.

9
Guide values for the geometrical and positional tolerances of bearing seating surfaces



Bearing tolerance class		Bearing seating surface	Standard tolerance grades to ISO 286-1 (IT grades)			
to ISO 492	to DIN 620		Diameter tolerance	Roundness tolerance	Parallelism tolerance	Total axial runout tolerance of abutment shoulder
				t ₁	t ₂	t ₃
Normal	PN (P0)	Shaft	IT6 (IT5)	Circumferential load IT4/2	Circumferential load IT4/2	IT4
				Point load IT5/2	Point load IT5/2	
		Housing	IT7 (IT6)	Circumferential load IT5/2	Circumferential load IT5/2	IT5
				Point load IT6/2	Point load IT6/2	

10
Numerical values for ISO standard tolerances (IT grades) to ISO 286-1:2010

IT grade	Nominal dimension in mm							
	over 18	30	50	80	120	180	250	315
	incl. 30	50	80	120	180	250	315	400
Values in μm								
IT4	6	7	8	10	12	14	16	18
IT5	9	11	13	15	18	20	23	25
IT6	13	16	19	22	25	29	32	36
IT7	21	25	30	35	40	46	52	57

 *Ra must not be too high*



Roughness of cylindrical bearing seating surfaces

The roughness of the bearing seats must be matched to the tolerance class of the bearings. The mean roughness value R_a must not be too high, in order to maintain the interference loss within limits. The shafts must be ground, while the bores must be precision turned. Guide values as a function of the IT grade of bearing seating surfaces  539 |  11.

 **11**
Roughness values
for cylindrical bearing seating
surfaces – guide values

Nominal diameter of the bearing seat d (D) mm		Recommended mean roughness value for ground bearing seats Ramax μm			
		Diameter tolerance (IT grade)			
over	incl.	IT7	IT6	IT5	IT4
–	80	1,6	0,8	0,4	0,2
80	500	1,6	1,6	0,8	0,4

Bearing seat design (roughness) for cylindrical roller bearings with annular slots (rope sheave bearings)

Recommended roughness values for bearing seating surfaces  539 |  12.



 **12**
Roughness for bearing seating
surfaces on the shaft and
in the housing bore for cylindrical
roller bearings with annular
slots – recommendation

Nominal diameter of bearing seat d (D) mm		Roughness	
over	incl.	Shaft	Housing bore
20	300	Rz 4	Rz 16









Mounting dimensions for the contact surfaces of bearing rings

 *The contact surfaces for the rings must be of sufficient height*

The mounting dimensions of the shaft and housing shoulders, and spacer rings etc., must ensure that the contact surfaces for the bearing rings are of sufficient height. The transition from the bearing seat to the abutment shoulder must be designed with rounding to DIN 5418:1993 or an undercut to DIN 509:2006. Proven mounting dimensions for the radii and diameters of abutment shoulders are given in the product tables  542 | . These dimensions are limiting dimensions (maximum or minimum dimensions); the actual values should not be higher or lower than specified.

 *Rib support in axially loaded bearings*

Ribs under axial load must be supported over their entire height and entire circumference  542 |  and  540 |  12. The size and axial runout accuracy of the contact surfaces on the inner ring rib must be observed especially in the case of cylindrical roller bearings subjected to high loads, since these factors also influence the uniformity of the rib load and the running accuracy of the shaft. This means that the ribs may be subjected to damaging alternating stresses even in the case of very small misalignments. If the mounting dimensions indicated in the product tables are observed, the problems described can be reliably avoided  542 | .

Support in semi-locating bearings

In semi-locating bearings, it is sufficient to support the bearing rings on one side, on the rib supporting the axial load ➤ 540 | 12.



Support of inner ring rib supporting axial load

d_c = recommended height of shaft shoulder with axially loaded rib
Arrow = force flow

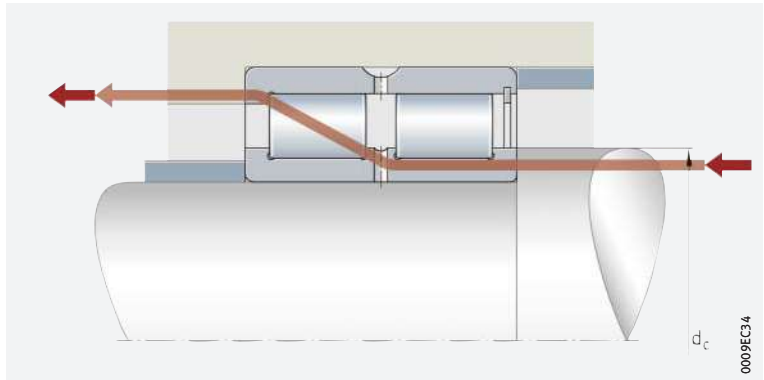

Support of sealing rings in cylindrical roller bearings with annular slots (rope sheave bearings)

Observe the abutment dimension of the sealing rings

The sealing rings must be supported to a sufficient height that they are not pressed out during lubrication of the bearings ➤ 540 | 13.
The dimension d_2 in the product tables must be observed ➤ 550 | 13.



Rope sheave bearings – support of sealing rings

d_2 = abutment dimension

① Sealing ring

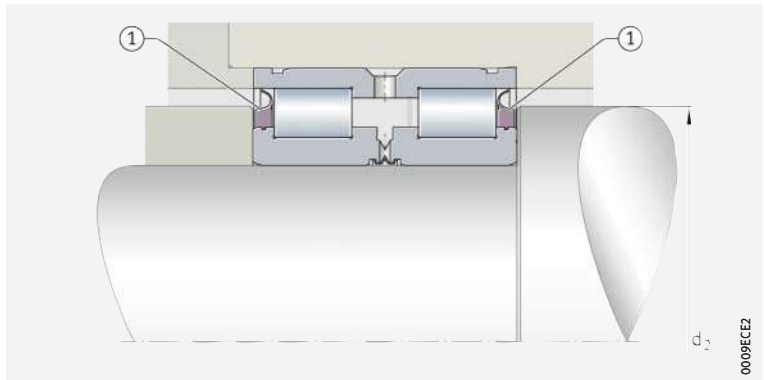

4.17 Mounting and dismounting



The mounting and dismounting options for cylindrical roller bearings, by thermal, hydraulic or mechanical methods, must be taken into consideration in the design of the bearing position.

As the bearings are not self-retaining, they are easy to mount

The series SL0248 and SL0249 are not self-retaining. As a result, the bearing parts (the inner ring with the rolling element set and the outer ring) can be mounted separately from each other ➤ 524 | 4.1. This gives simplified mounting of the bearings, especially when the two bearing rings have a tight fit.

Mounting and dismounting of cylindrical roller bearings with annular slots (rope sheave bearings)



During mounting and dismounting of the bearings, the mounting forces must never be directed through the rolling elements, sealing rings or the fasteners on the split bearing ring.

 *Rolling bearings must be handled with great care*

Schaeffler Mounting Handbook

Rolling bearings are well-proven precision machine elements for the design of economical and reliable bearing arrangements, which offer high operational security. In order that these products can function correctly and achieve the envisaged operating life without detrimental effect, they must be handled with care.



The Schaeffler Mounting Handbook MH 1 gives comprehensive information about the correct storage, mounting, dismounting and maintenance of rotary rolling bearings ► <https://www.schaeffler.de/std/1D53>. It also provides information which should be observed by the designer, in relation to the mounting, dismounting and maintenance of bearings, in the original design of the bearing position. This book is available from Schaeffler on request.

4.18 Legal notice regarding data freshness

 *The further development of products may also result in technical changes to catalogue products*

Of central interest to Schaeffler is the further development and optimisation of its products and the satisfaction of its customers. In order that you, as the customer, can keep yourself optimally informed about the progress that is being made here and with regard to the current technical status of the products, we publish any product changes which differ from the printed version in our electronic product catalogue.



We therefore reserve the right to make changes to the data and illustrations in this catalogue. This catalogue reflects the status at the time of printing. More recent publications released by us (as printed or digital media) will automatically precede this catalogue if they involve the same subject. Therefore, please always use our electronic product catalogue to check whether more up-to-date information or modification notices exist for your desired product.

Link to electronic product catalogue



The following link will take you to the Schaeffler electronic product catalogue: ► <https://medias.schaeffler.com>.



4.19 Further information



In addition to the data in this chapter, the following chapters in Technical principles must also be observed in the design of bearing arrangements:

- Determining the bearing size ► 34
- Rigidity ► 54
- Friction and increases in temperature ► 56
- Speeds ► 64
- Bearing data ► 97
- Lubrication ► 70
- Sealing ► 182
- Design of bearing arrangements ► 139
- Mounting and dismounting ► 191.

Double row full complement cylindrical roller bearings

Semi-locating, locating and non-locating bearings

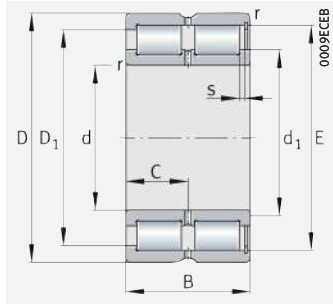

SL1850
Semi-locating bearing

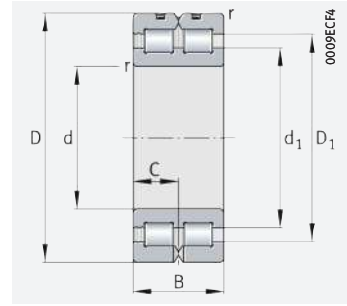

SL0148, SL0149
Locating bearings

d = 20 – 120 mm

Main dimensions			Basic load ratings		Fatigue limit load C_{ur} N	Limiting speed n_G min^{-1}	Speed rating $n_{\theta r}$ min^{-1}	Mass m \approx kg	Designation		
d	D	B	dyn. C_r N	stat. C_{0r} N					Semi-locating bearing	Locating bearing	Non-locating bearing
20	42	30	53 000	52 000	8 900	11 400	7 400	0,2	SL185004-XL	-	-
25	47	30	60 000	64 000	11 100	9 500	6 000	0,23	SL185005-XL	-	-
30	55	34	78 000	84 000	15 000	8 100	5 300	0,35	SL185006-XL	-	-
35	62	36	94 000	107 000	18 800	7 100	4 750	0,46	SL185007-XL	-	-
40	68	38	113 000	133 000	22 400	6 300	4 200	0,56	SL185008-XL	-	-
45	75	40	120 000	148 000	24 900	5 800	3 950	0,71	SL185009-XL	-	-
50	80	40	151 000	188 000	30 000	5 300	3 450	0,76	SL185010-XL	-	-
55	90	46	206 000	275 000	45 000	4 550	2 900	1,16	SL185011-XL	-	-
60	85	25	70 000	121 000	17 300	4 650	2 650	0,49	-	SL014912	-
	85	25	70 000	121 000	17 300	4 650	2 650	0,47	-	-	SL024912
	95	46	212 000	285 000	47 500	4 350	2 800	1,24	SL185012-XL	-	-
65	100	46	223 000	315 000	52 000	4 000	2 500	1,32	SL185013-XL	-	-
70	100	30	106 000	185 000	27 000	3 900	2 330	0,78	-	SL014914	-
	100	30	106 000	185 000	27 000	3 900	2 330	0,75	-	-	SL024914
	110	54	265 000	350 000	59 000	3 750	2 650	1,85	SL185014-XL	-	-
75	115	54	275 000	385 000	65 000	3 450	2 370	1,93	SL185015-XL	-	-
80	110	30	112 000	206 000	30 000	3 550	2 090	0,88	-	SL014916	-
	110	30	112 000	206 000	30 000	3 550	2 090	0,85	-	-	SL024916
	125	60	330 000	440 000	81 000	3 200	2 320	2,59	SL185016-XL	-	-
85	130	60	300 000	465 000	68 000	3 050	2 210	2,72	SL185017	-	-
90	125	35	153 000	290 000	39 000	3 050	1 870	1,35	-	SL014918	-
	125	35	153 000	290 000	39 000	3 050	1 870	1,3	-	-	SL024918
	140	67	350 000	550 000	80 000	2 850	2 140	3,62	SL185018	-	-
100	140	40	191 000	370 000	47 500	2 700	1 720	1,95	-	SL014920	-
	140	40	191 000	370 000	47 500	2 700	1 720	1,9	-	-	SL024920
	150	67	370 000	600 000	86 000	2 600	1 930	3,94	SL185020	-	-
110	150	40	198 000	400 000	50 000	2 500	1 600	2,15	-	SL014922	-
	150	40	198 000	400 000	50 000	2 500	1 600	2,1	-	-	SL024922
	170	80	485 000	770 000	109 000	2 350	1 730	6,32	SL185022	-	-
120	165	45	222 000	440 000	55 000	2 260	1 540	2,95	-	SL014924	-
	165	45	222 000	440 000	55 000	2 260	1 540	2,85	-	-	SL024924
	180	80	510 000	850 000	117 000	2 160	1 530	6,77	SL185024	-	-

medias ► <https://www.schaeffler.de/std/1E43>

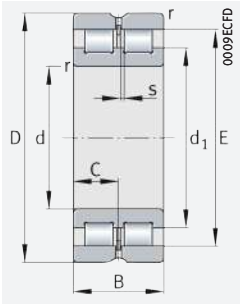

SL0248, SL0249
Non-locating bearings

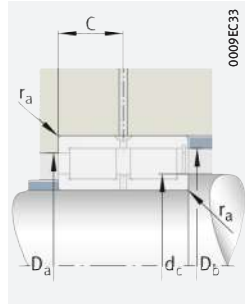

Mounting dimensions
for semi-locating bearings

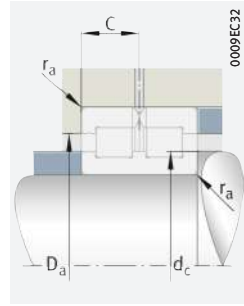

Mounting dimensions
for locating bearings

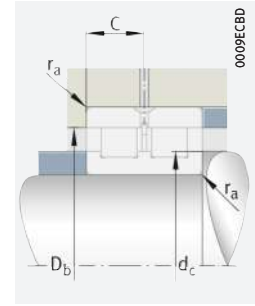

Mounting dimensions
for non-locating bearings

d	Designation to DIN 5412	Dimensions						Mounting dimensions			
		r	s	C	d ₁	D ₁	E	d _c	D _a	D _b	r _a
		min.			≈	≈					max.
20	–	0,6	1	15	28,4	33,3	36,8	28	33,5	36,5	0,6
25	–	0,6	1	15	34,5	39	42,5	34,5	39	42,5	0,6
30	–	1	1,5	17	40	45,3	49,6	40	45,5	49,5	1
35	–	1	1,5	18	44,9	51,2	55,5	44,5	51,5	55,5	1
40	–	1	1,5	19	50,5	57,2	61,7	50,5	57,5	61,5	1
45	–	1	1,5	20	55,3	62,6	66,9	55	63	66,5	1
50	–	1	1,5	20	59,1	67,6	72,3	59	68	72	1
55	–	1,1	1,5	23	68,5	78,7	83,5	68,5	79	83,5	1,1
60	NNC4912V	1	–	12,5	70,3	73,5	–	70	73,5	–	1
	NNCL4912V	1	1	12,5	70,3	–	77,51	70,5	–	77,5	1
	–	1,1	1,5	23	71,7	81,9	86,7	71,5	82	86,5	1,1
65	–	1,1	1,5	23	78,1	88,3	93,1	78	88,5	93	1,1
70	NNC4914V	1	–	15	82,5	87,4	–	82,5	87,5	–	1
	NNCL4914V	1	1	15	82,5	–	91,87	82,5	–	91,5	1
	–	1,1	3	27	81,5	95,7	100,3	81,5	96	100	1,1
75	–	1,1	3	27	89	102,9	107,9	89	103	107,5	1,1
80	NNC4916V	1	–	15	91,4	96,2	–	91	96,5	–	1
	NNCL4916V	1	1	15	91,4	–	100,78	91,5	–	100,5	1
	–	1,1	3,5	30	95	111,7	117,4	95	112	117	1,1
85	–	1,1	3,5	30	99	116,1	122	99	116,5	121,5	1,1
90	NNC4918V	1,1	–	17,5	103,9	110,7	–	103,5	111	–	1,1
	NNCL4918V	1,1	1,5	17,5	103	–	115,2	103	–	115	1,1
	–	1,5	4	33,5	106,1	124,5	130,7	106	124,5	130,5	1,5
100	NNC4920V	1,1	–	20	116,4	125	–	116	125	–	1,1
	NNCL4920V	1,1	2	20	116,4	–	129,6	116,5	–	129,5	1,1
	–	1,5	4	33,5	115,7	134	140,2	115,5	134	140	1,5
110	NNC4922V	1,1	–	20	125	133,6	–	125	134	–	1,1
	NNCL4922V	1,1	2	20	125	–	138,2	125	–	138	1,1
	–	2	5	40	127,3	149,3	156,7	127	149,5	156,5	2
120	NNC4924V	1,1	–	22,5	138,6	148,6	–	138,5	149	–	1,1
	NNCL4924V	1,1	3	22,5	138,6	–	153,55	139	–	153,5	1,1
	–	2	5	40	138,8	160,7	168,2	138,5	161	168	2



Double row full complement cylindrical roller bearings

Semi-locating, locating and non-locating bearings

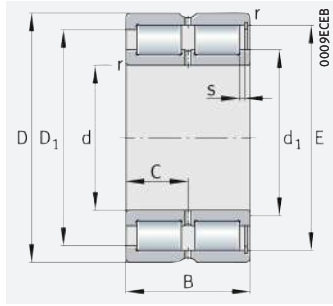

SL1850
Semi-locating bearing

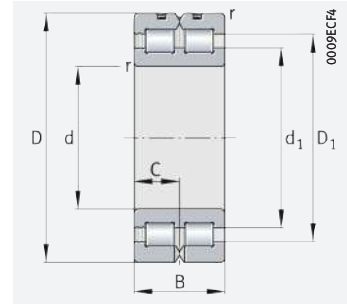

SL0148, SL0149
Locating bearings

d = 130 – 190 mm

Main dimensions			Basic load ratings		Fatigue limit load	Limiting speed	Speed rating	Mass	Designation			
d	D	B	dyn. C _r	stat. C _{0r}	C _{ur}	n _G	n _{θr}	m	► 534 4.12	► 535 4.13		
			N	N	N	min ⁻¹	min ⁻¹	≈ kg	Semi-locating bearing	Locating bearing	Non-locating bearing	
130	180	50	260 000	510 000	63 000	2 090	1 500	3,95	–	SL014926	–	
	180	50	260 000	510 000	63 000	2 090	1 500	3,8	–	–	SL024926	
	200	95	730 000	1 210 000	164 000	1 990	1 340	10,2	SL185026	–	–	
140	190	50	270 000	550 000	66 000	1 950	1 370	4,2	–	SL014928	–	
	190	50	270 000	550 000	66 000	1 950	1 370	4,1	–	–	SL024928	
	210	95	770 000	1 330 000	177 000	1 820	1 180	11,1	SL185028	–	–	
150	190	40	231 000	530 000	62 000	1 900	1 270	2,9	–	SL014830	–	
	190	40	231 000	530 000	62 000	1 900	1 270	2,8	–	–	SL024830	
	210	60	410 000	820 000	104 000	1 790	1 200	6,65	–	SL014930	–	
	210	60	410 000	820 000	104 000	1 790	1 200	6,45	–	–	SL024930	
	225	100	810 000	1 390 000	183 000	1 740	1 150	13,3	SL185030	–	–	
160	200	40	237 000	560 000	64 000	1 800	1 200	3,1	–	SL014832	–	
	200	40	237 000	560 000	64 000	1 800	1 200	3	–	–	SL024832	
	220	60	425 000	880 000	110 000	1 660	1 080	7	–	SL014932	–	
	220	60	425 000	880 000	110 000	1 660	1 080	6,8	–	–	SL024932	
	240	109	930 000	1 610 000	207 000	1 600	1 030	12,2	SL185032	–	–	
170	215	45	260 000	600 000	68 000	1 670	1 180	4,1	–	SL014834	–	
	215	45	260 000	600 000	68 000	1 670	1 180	3,95	–	–	SL024834	
	230	60	435 000	930 000	114 000	1 580	1 010	7,35	–	SL014934	–	
	230	60	435 000	930 000	114 000	1 580	1 010	7,1	–	–	SL024934	
	260	122	1 200 000	2 110 000	265 000	1 480	900	22,5	SL185034	–	–	
180	225	45	270 000	640 000	72 000	1 560	1 070	4,3	–	SL014836	–	
	225	45	270 000	640 000	72 000	1 560	1 070	4,15	–	–	SL024836	
	250	69	570 000	1 200 000	147 000	1 480	920	10,8	–	SL014936	–	
	250	69	570 000	1 200 000	147 000	1 480	920	10,5	–	–	SL024936	
	280	136	1 390 000	2 480 000	310 000	1 370	820	29,9	SL185036-TB	–	–	
190	240	50	310 000	730 000	81 000	1 480	1 030	5,65	–	SL014838	–	
	240	50	310 000	730 000	81 000	1 480	1 030	5,45	–	–	SL024838	
	260	69	580 000	1 270 000	152 000	1 410	860	11,2	–	SL014938	–	
	260	69	580 000	1 270 000	152 000	1 410	860	10,9	–	–	SL024938	
	290	136	1 430 000	2 600 000	320 000	1 320	770	31,3	SL185038-TB	–	–	

medias ► <https://www.schaeffler.de/std/1E44>

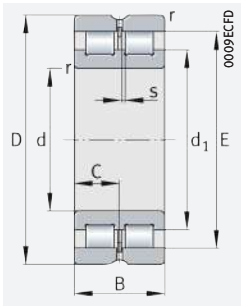

SL0248, SL0249
Non-locating bearings

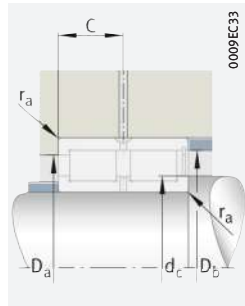

Mounting dimensions
for semi-locating bearings

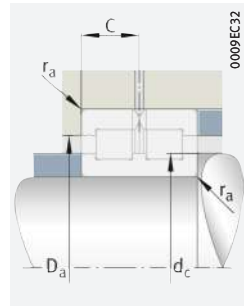

Mounting dimensions
for locating bearings

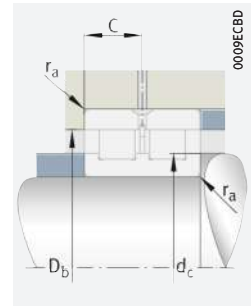

Mounting dimensions
for non-locating bearings

d	Designation to DIN 5412	Dimensions						Mounting dimensions			
		r	s	C	d ₁	D ₁	E	d _c	D _a	D _b	r _a
		min.			≈	≈					max.
130	NNC4926V	1,5	–	25	148,4	160	–	148	160	–	1,5
	NNCL4926V	1,5	4	25	149,5	–	165,4	149,5	–	165	1,5
	–	2	5	47,5	148,6	175,5	184,4	148,5	175,5	184	2
140	NNC4928V	1,5	–	25	159	170,5	–	159	170,5	–	1,5
	NNCL4928V	1,5	4	25	160	–	175,9	160	–	175,5	1,5
	–	2	5	47,5	162,6	189,5	198,4	162,5	189,5	198	2
150	NNC4830V	1,1	–	20	165,1	174,2	–	165	174,5	–	1,1
	NNCL4830V	1,1	2	20	165,1	–	178,3	165,5	–	178	1,1
	NNC4930V	2	–	30	171,8	187,2	–	171,5	187,5	–	2
	NNCL4930V	2	4	30	171,8	–	192,77	172	–	192,5	2
	–	2	6	50	170	198	207,5	170	198	207	2
160	NNC4832V	1,1	–	20	173,7	182,8	–	173,5	183	–	1,1
	NNCL4832V	1,1	2	20	173,7	–	186,9	174	–	186,5	1,1
	NNC4932V	2	–	30	184,2	200,3	–	184	200,5	–	2
	NNCL4932V	2	4	30	184,2	–	206,16	184,5	–	206	2
	–	2,1	6	54,5	184,8	215,8	224,8	184,5	216	224,5	2,1
170	NNC4834V	1,1	–	22,5	186,3	197	–	186	197	–	1,1
	NNCL4834V	1,1	3	22,5	186,3	–	201,3	186,5	–	201	1,1
	NNC4934V	2	–	30	193,1	209,1	–	193	209,5	–	2
	NNCL4934V	2	4	30	193,1	–	215,08	193,5	–	215	2
	–	2,1	6	61	198	232,7	242,9	198	233	242,5	2,1
180	NNC4836V	1,1	–	22,5	199,1	209,8	–	199	210	–	1,1
	NNCL4836V	1,1	3	22,5	199,1	–	214,1	199,5	–	214	1,1
	NNC4936V	2	–	34,5	204,9	224,1	–	204,5	224,5	–	2
	NNCL4936V	2	4	34,5	204,9	–	230,5	205	–	230,5	2
	–	2,1	8	68	212,2	249,4	260,2	212	249,5	260	2,1
190	NNC4838V	1,5	–	25	207,6	220,7	–	207,5	221	–	1,5
	NNCL4838V	1,5	4	25	207,6	–	225	208	–	225	1,5
	NNC4938V	2	–	34,5	215	234,3	–	215	234,5	–	2
	NNCL4938V	2	4	34,5	215	–	240,7	215	–	240,5	2
	–	2,1	8,2	68	221,8	259	269,8	221,5	259	269,5	2,1



Double row full complement cylindrical roller bearings

Semi-locating, locating and non-locating bearings

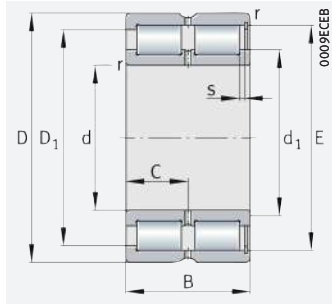

SL1850
Semi-locating bearing

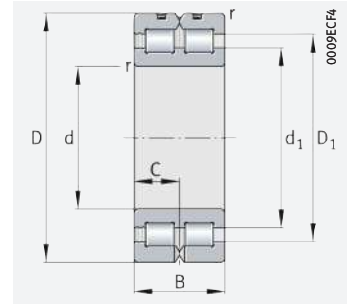

SL0148, SL0149
Locating bearings

d = 200 – 300 mm

Main dimensions			Basic load ratings		Fatigue limit load C_{ur} N	Limiting speed n_G min ⁻¹	Speed rating $n_{\theta r}$ min ⁻¹	Mass m ≈ kg	Designation		
d	D	B	dyn. C_r N	stat. C_{0r} N					▶ 534 4.12	▶ 535 4.13	Semi-locating bearing
200	250	50	320 000	770 000	84 000	1 410	960	5,9	–	SL014840	–
	250	50	320 000	770 000	84 000	1 410	960	5,7	–	–	SL024840
	280	80	680 000	1 440 000	173 000	1 310	820	15,8	–	SL014940	–
	280	80	680 000	1 440 000	173 000	1 310	820	15,3	–	–	SL024940
	310	150	1 630 000	3 000 000	365 000	1 230	710	40,4	SL185040-TB	–	–
220	270	50	335 000	840 000	90 000	1 290	850	6,4	–	SL014844	–
	270	50	335 000	840 000	90 000	1 290	850	6,2	–	–	SL024844
	300	80	700 000	1 550 000	182 000	1 220	750	17,2	–	SL014944	–
	300	80	700 000	1 550 000	182 000	1 220	750	16,7	–	–	SL024944
	340	160	1 980 000	3 650 000	430 000	1 140	630	51,6	SL185044-TB	–	–
240	300	60	510 000	1 260 000	143 000	1 170	730	10	–	SL014848	–
	300	60	510 000	1 260 000	143 000	1 170	730	9,9	–	–	SL024848
	320	80	740 000	1 700 000	195 000	1 110	660	18,5	–	SL014948	–
	320	80	740 000	1 700 000	195 000	1 110	660	17,9	–	–	SL024948
	360	160	2 080 000	4 000 000	460 000	1 040	550	55,2	SL185048-TB	–	–
260	320	60	540 000	1 370 000	152 000	1 080	650	11	–	SL014852	–
	320	60	540 000	1 370 000	152 000	1 080	650	10,6	–	–	SL024852
	360	100	1 100 000	2 470 000	280 000	1 010	570	32	–	SL014952	–
	360	100	1 100 000	2 470 000	280 000	1 010	570	31,2	–	–	SL024952
	400	190	2 750 000	5 000 000	570 000	940	490	82,6	SL185052-TB	–	–
280	350	69	700 000	1 820 000	198 000	980	570	16	–	SL014856	–
	350	69	700 000	1 820 000	198 000	980	570	15,6	–	–	SL024856
	380	100	1 150 000	2 650 000	295 000	940	520	34	–	SL014956	–
	380	100	1 150 000	2 650 000	295 000	940	520	33,1	–	–	SL024956
	420	190	2 850 000	5 300 000	590 000	900	460	88	SL185056-TB	–	–
300	380	80	820 000	2 070 000	225 000	920	550	23	–	SL014860	–
	380	80	820 000	2 070 000	225 000	920	550	22	–	–	SL024860
	420	118	1 630 000	3 700 000	405 000	870	445	53	–	SL014960	–
	420	118	1 630 000	3 700 000	405 000	870	445	51,9	–	–	SL024960
	460	218	3 450 000	6 600 000	660 000	800	395	124	SL185060-TB	–	–

medias ▶ <https://www.schaeffler.de/std/1E45>

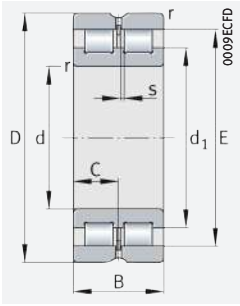

SL0248, SL0249
Non-locating bearings

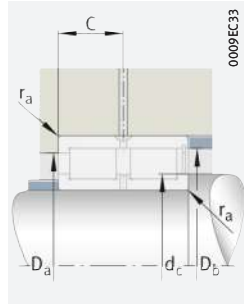

Mounting dimensions
for semi-locating bearings

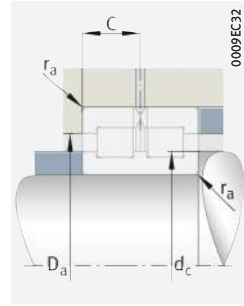

Mounting dimensions
for locating bearings

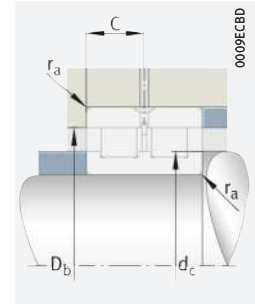

Mounting dimensions
for non-locating bearings

d	Designation to DIN 5412	Dimensions						Mounting dimensions			
		r	s	C	d ₁	D ₁	E	d _c	D _a	D _b	r _a
		min.			≈	≈					max.
200	NNC4840V	1,5	–	25	218,1	231,2	–	218	231,5	–	1,5
	NNCL4840V	1,5	4	25	218,1	–	235,5	218,5	–	235,5	1,5
	NNC4940V	2,1	–	40	230,5	252,3	–	230,5	252,5	–	2,1
	NNCL4940V	2,1	5	40	230,5	–	259,34	230,5	–	259	2,1
	–	2,1	8,9	75	236,6	276,2	287,8	236,5	276,5	287,5	2,1
220	NNC4844V	1,5	–	25	239,1	252,3	–	239	252,5	–	1,5
	NNCL4844V	1,5	4	25	239,1	–	256,5	239,5	–	256,5	1,5
	NNC4944V	2,1	–	40	248	268,5	–	248	268,5	–	2,1
	NNCL4944V	2,1	5	40	248	–	276,52	248	–	276,5	2,1
	–	3	9	80	254,6	297,8	312,2	254,5	298	312	3
240	NNC4848V	2	–	30	259,5	276,7	–	259,5	277	–	2
	NNCL4848V	2	4	30	259,5	–	281,9	259,5	–	281,5	2
	NNC4948V	2,1	–	40	270,6	292,3	–	270,5	292,5	–	2,1
	NNCL4948V	2,1	5	40	270,6	–	299,46	271	–	299	2,1
	–	3	9	80	277,5	322,1	335,1	277,5	322,5	335	3
260	NNC4852V	2	–	30	281,8	298,8	–	281,5	299	–	2
	NNCL4852V	2	4	30	281,8	–	304,2	282	–	304	2
	NNC4952V	2,1	–	50	294,5	322,1	–	294,5	322,5	–	2,1
	NNCL4952V	2,1	6	50	294,5	–	331,33	294,5	–	331	2,1
	–	4	11,3	95	304	359,7	376	304	360	375,5	4
280	NNC4856V	2	–	34,5	306,8	326,4	–	306,5	326,5	–	2
	NNCL4856V	2	4	34,5	306,8	–	332,4	307	–	332	2
	NNC4956V	2,1	–	50	316,5	344,6	–	316,5	345	–	2,1
	NNCL4956V	2,1	6	50	316,5	–	353,34	316,5	–	353	2,1
	–	4	11,3	95	318,3	374,1	390,3	318	374,5	390	4
300	NNC4860V	2,1	–	40	327,9	349,9	–	327,5	350	–	2,1
	NNCL4860V	2,1	6	40	327,9	–	356,7	328	–	356,5	2,1
	NNC4960V	3	–	59	340,7	374,3	–	340,5	374,5	–	3
	NNCL4960V	3	6	59	340,7	–	385,51	341	–	385,5	3
	–	4	12,5	109	353,6	413,6	433,6	353,5	414	433,5	4



Double row full complement cylindrical roller bearings

Semi-locating, locating and non-locating bearings

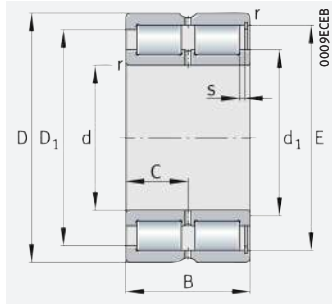

SL1850
Semi-locating bearing

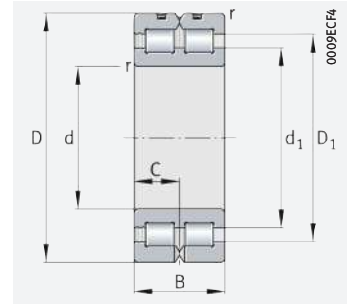

SL0148, SL0149
Locating bearings

d = 320 – 400 mm

Main dimensions			Basic load ratings		Fatigue limit load	Limiting speed	Speed rating	Mass	Designation				
d	D	B	dyn. C _r	stat. C _{0r}	C _{ur}	n _G	n _{∅r}	m	► 534 4.12	► 535 4.13	Semi-locating bearing	Locating bearing	Non-locating bearing
			N	N	N	min ⁻¹	min ⁻¹	≈ kg					
320	400	80	850 000	2 220 000	236 000	860	495	24	–	–	SL014864	–	–
	400	80	850 000	2 220 000	236 000	860	495	23,5	–	–	–	–	SL024864
	440	118	1 700 000	4 050 000	430 000	800	395	56	–	–	SL014964	–	–
	440	118	1 700 000	4 050 000	430 000	800	395	54,9	–	–	–	–	SL024964
	480	218	3 550 000	6 900 000	690 000	770	375	128,4	SL185064-TB	–	–	–	–
340	420	80	870 000	2 330 000	244 000	810	465	25,5	–	–	SL014868	–	–
	420	80	870 000	2 330 000	244 000	810	465	25	–	–	–	–	SL024868
	460	118	1 750 000	4 250 000	445 000	770	375	59	–	–	SL014968	–	–
	460	118	1 750 000	4 250 000	445 000	770	375	57,8	–	–	–	–	SL024968
	520	243	4 250 000	8 300 000	790 000	710	335	178	SL185068-TB	–	–	–	–
360	440	80	900 000	2 480 000	255 000	770	430	27	–	–	SL014872	–	–
	440	80	900 000	2 480 000	255 000	770	430	26	–	–	–	–	SL024872
	480	118	1 790 000	4 450 000	460 000	730	350	62,1	–	–	SL014972	–	–
	480	118	2 020 000	4 450 000	560 000	730	350	60,8	–	–	–	–	SL024972
	540	243	4 400 000	8 700 000	820 000	680	320	178	SL185072-TB	–	–	–	–
380	480	100	1 320 000	3 500 000	360 000	710	375	45,5	–	–	SL014876	–	–
	480	100	1 320 000	3 500 000	360 000	710	375	44	–	–	–	–	SL024876
	520	140	2 250 000	5 500 000	580 000	680	325	92,4	–	–	SL014976	–	–
	520	140	2 250 000	5 500 000	580 000	680	325	90,5	–	–	–	–	SL024976
	560	243	4 450 000	8 900 000	850 000	660	305	196,5	SL185076-TB	–	–	–	–
400	500	100	1 350 000	3 650 000	370 000	680	360	46,5	–	–	SL014880	–	–
	500	100	1 350 000	3 650 000	370 000	680	360	45,8	–	–	–	–	SL024880
	540	140	2 310 000	5 800 000	600 000	650	300	96,5	–	–	SL014980	–	–
	540	140	2 310 000	5 800 000	600 000	650	300	94,6	–	–	–	–	SL024980

medias ► <https://www.schaeffler.de/std/1E46>

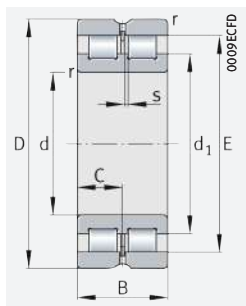

SL0248, SL0249
Non-locating bearings

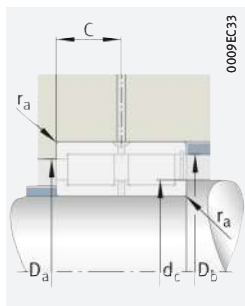

Mounting dimensions
for semi-locating bearings

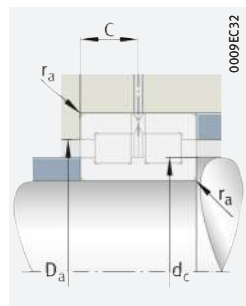

Mounting dimensions
for locating bearings

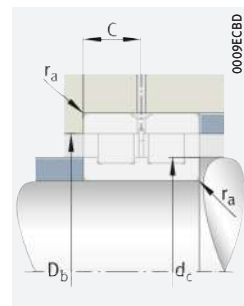

Mounting dimensions
for non-locating bearings

d	Designation to DIN 5412	Dimensions						Mounting dimensions			
		r	s	C	d ₁	D ₁	E	d _c	D _a	D _b	r _a
		min.			≈	≈					max.
320	NNC4864V	2,1	–	40	350,9	372,9	–	350,5	373	–	2,1
	NNCL4864V	2,1	6	40	350,9	–	379,7	351	–	379,5	2,1
	NNC4964V	3	–	59	367,5	401,1	–	367,5	401,5	–	3
	NNCL4964V	3	6	59	367,5	–	412,27	367,5	–	412	3
	–	4	12,5	109	369,5	431,5	449,5	369,5	431,5	449,5	4
340	NNC4868V	2,1	–	40	368,1	390,1	–	368	390,5	–	2,1
	NNCL4868V	2,1	6	40	368,1	–	396,9	368,5	–	396,5	2,1
	NNC4968V	3	–	59	385,3	418,9	–	385	419	–	3
	NNCL4968V	3	6	59	385,3	–	430,11	385,5	–	430	3
	–	5	14,3	121,5	396	465,5	485,7	396	465,5	485,5	5
360	NNC4872V	2,1	–	40	391	413,2	–	391	413,5	–	2,1
	NNCL4872V	2,1	6	40	391	–	419,8	391	–	419,5	2,1
	NNC4972V	3	–	59	404	436,8	–	404	437	–	3
	NNCL4972V	3	6	59	404	–	447,95	404	–	447,5	3
	–	5	14	121,5	413,8	481	503,5	413,5	481	503	5
380	NNC4876V	2,1	–	50	419	447,2	–	419	447,5	–	2,1
	NNCL4876V	2,1	6	50	419	–	455,8	419	–	455,5	2,1
	NNC4976V	4	–	70	430,2	468,7	–	430	469	–	4
	NNCL4976V	4	7	70	430,2	–	481,35	430,5	–	481	4
	–	5	14,1	121,5	432	499	521,3	432	499	521	5
400	NNC4880V	2,1	–	50	433,8	462	–	433,5	462	–	2,1
	NNCL4880V	2,1	6	50	433,8	–	470,59	434	–	470,5	2,1
	NNC4980V	4	–	70	450,5	489	–	450,5	489	–	4
	NNCL4980V	4	7	70	450,5	–	501,74	450,5	–	501,5	4



Double row full complement cylindrical roller bearings

With annular slots
Locating bearings

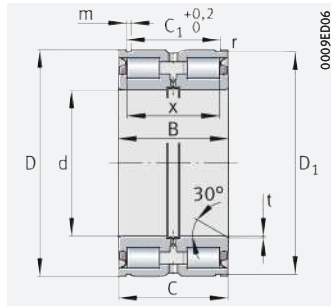

SL0450..-PP
SL04..-PP

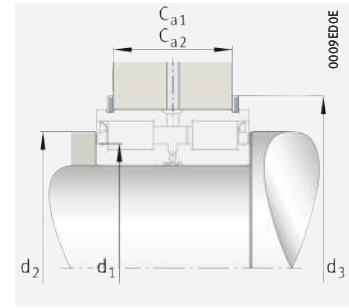

Mounting dimensions

d = 20 – 160 mm

Main dimensions			Basic load ratings		Fatigue limit load	Limiting speed	Mass	Designation
d	D	B	dyn. C_r N	stat. C_{0r} N	C_{ur} N	n_G grease min^{-1}	m \approx kg	▶ 534 4.12 ▶ 535 4.13
20	42	30	41 500	51 000	6 900	5 500	0,2	SL045004-D-PP
25	47	30	46 000	60 000	8 100	4 700	0,24	SL045005-D-PP
30	55	34	50 000	67 000	9 500	4 100	0,37	SL045006-D-PP
35	62	36	63 000	88 000	12 400	3 550	0,48	SL045007-D-PP
40	68	38	80 000	111 000	16 000	3 150	0,56	SL045008-D-PP
45	75	40	97 000	139 000	19 900	2 800	0,7	SL045009-D-PP
50	80	40	102 000	151 000	21 700	2 600	0,76	SL045010-D-PP
55	90	46	120 000	186 000	25 500	2 340	1,18	SL045011-D-PP
60	95	46	125 000	201 000	27 500	2 180	1,26	SL045012-D-PP
65	100	46	130 000	215 000	29 500	2 040	1,33	SL045013-D-PP
70	110	54	175 000	275 000	36 000	1 850	1,87	SL045014-D-PP
75	115	54	201 000	315 000	42 000	1 740	1,96	SL045015-D-PP
80	125	60	210 000	340 000	45 000	1 620	2,71	SL045016-D-PP
85	130	60	219 000	365 000	47 500	1 510	2,83	SL045017-D-PP
90	140	67	305 000	510 000	69 000	1 410	3,71	SL045018-D-PP
95	145	67	315 000	530 000	71 000	1 360	3,88	SL045019-D-PP
100	150	67	330 000	550 000	78 000	1 300	3,95	SL045020-D-PP
110	170	80	395 000	680 000	94 000	1 170	6,57	SL045022-D-PP
120	180	80	410 000	740 000	99 000	1 090	7,04	SL045024-D-PP
130	200	95	540 000	960 000	128 000	960	10,5	SL045026-D-PP
140	190	80	430 000	790 000	105 000	1 020	7,5	SL04130-D-PP
	210	95	610 000	1 100 000	146 000	910	11,1	SL045028-D-PP
150	200	80	445 000	840 000	110 000	960	8	SL04140-D-PP
	225	100	710 000	1 260 000	163 000	850	13,3	SL045030-D-PP
160	210	80	465 000	920 000	117 000	880	8,4	SL04150-D-PP
	240	109	740 000	1 360 000	173 000	790	16,6	SL045032-D-PP
	220	80	480 000	970 000	122 000	830	8,8	SL04160-D-PP

medias ▶ <https://www.schaeffler.de/std/1E47>

- 1) For snap rings WRE.
- 2) For retaining ring to DIN 471.



Dimensions								Mounting dimensions					Snap ring WRE	Retaining ring to DIN 471
d	C	C ₁	D ₁	m	r	t	x	C _{a1} ¹⁾	C _{a2} ²⁾	d ₁	d ₂	d ₃ ¹⁾		
		+0,2			min.			-0,2	-0,2					
20	29	24,7	40,2	1,8	0,3	0,5	22,5	21,5	21	31	34	47	WRE42	42×1,75
25	29	24,7	45,2	1,8	0,3	0,5	22,5	21,5	21	35,5	39	52	WRE47	47×1,75
30	33	28,2	53	2,1	0,3	0,5	25,5	25	24	41	44	60	WRE55	55×2
35	35	30,2	60	2,1	0,3	0,5	27,5	27	26	46,5	50	67	WRE62	62×2
40	37	32,2	65,8	2,7	0,6	0,8	28,5	28	27	51,5	55	75	WRE68	68×2,5
45	39	34,2	72,8	2,7	0,6	0,8	30,5	30	29	57	61	82	WRE75	75×2,5
50	39	34,2	77,8	2,7	0,6	0,8	30,5	30	29	62	66	87	WRE80	80×2,5
55	45	40,2	87,4	3,2	0,6	1	36	35	34	69	73	99	WRE90	90×3
60	45	40,2	92,4	3,2	0,6	1	36	35	34	74	79	104	WRE95	95×3
65	45	40,2	97,4	3,2	0,6	1	36	35	34	79	84	109	WRE100	100×3
70	53	48,2	107,1	4,2	0,6	1	42	43	40	84,5	91	119	WRE110	110×4
75	53	48,2	112,1	4,2	0,6	1	42	43	40	90	97	124	WRE115	115×4
80	59	54,2	122,1	4,2	0,6	1,5	48	49	46	97,5	105	137	WRE125	125×4
85	59	54,2	127,1	4,2	0,6	1,5	48	49	46	104	112	142	WRE130	130×4
90	66	59,2	137	4,2	0,6	1,5	54	54	51	109,5	118	152	WRE140	140×4
95	66	59,2	142	4,2	0,6	1,5	54	54	51	113,5	122	157	WRE145	145×4
100	66	59,2	147	4,2	0,6	1,5	54	54	51	117,5	128	162	WRE150	150×4
110	79	70,2	167	4,2	0,6	1,8	64	65	62	132	143	182	WRE170	170×4
120	79	71,2	176	4,2	0,6	1,8	64	65	63	141	153	196	WRE180	180×4
130	94	83,2	196	4,2	0,6	1,8	77	77	75	157	170	216	WRE200	200×4
	79	71,2	186	4,2	0,6	1,8	64	65	63	151	160	206	WRE190	190×4
140	94	83,2	206	5,2	0,6	1,8	77	77	73	165,5	181	226	WRE210	210×5
	79	71,2	196	4,2	0,6	1,8	64	65	63	160	170	216	WRE200	200×4
150	99	87,2	221	5,2	0,6	2	80	81	77	176	192	245	WRE225	225×5
	79	71,2	206	5,2	0,6	1,8	64	65	61	174,5	185	226	WRE210	210×5
160	108	95,2	236	5,2	0,6	2	89	89	85	189	207	260	WRE240	240×5
	79	71,2	216	5,2	0,6	1,8	64	65	61	184,5	196	236	WRE220	220×5



Double row full complement cylindrical roller bearings

With annular slots
Locating bearings

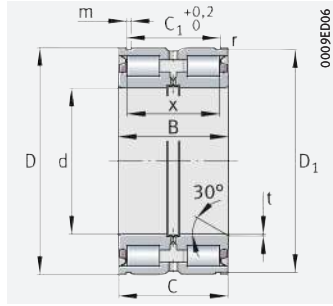

SL0450..-PP
SL04..-PP

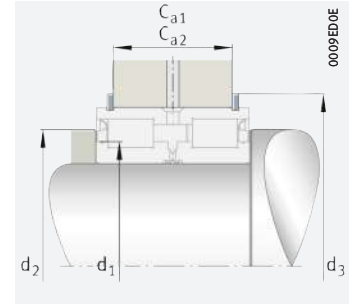

Mounting dimensions

d = 170 – 300 mm

Main dimensions			Basic load ratings		Fatigue limit load C_{ur} N	Limiting speed n_G grease min^{-1}	Mass m \approx kg	Designation ► 534 4.12 ► 535 4.13
d	D	B	dyn. C_r N	stat. C_{0r} N				
170	260	122	960 000	1 750 000	220 000	740	22,6	SL045034-D-PP
	230	80	490 000	1 030 000	127 000	790	9,3	SL04170-D-PP
180	280	136	1 140 000	2 130 000	265 000	680	30,1	SL045036-D-PP
	240	80	500 000	1 080 000	132 000	750	9,8	SL04180-D-PP
190	290	136	1 160 000	2 210 000	270 000	660	31,5	SL045038-D-PP
	260	80	520 000	1 160 000	139 000	700	12,7	SL04190-D-PP
200	310	150	1 350 000	2 600 000	310 000	610	40,8	SL045040-D-PP
	270	80	540 000	1 210 000	143 000	670	13,2	SL04200-D-PP
220	340	160	1 570 000	3 050 000	365 000	560	52,5	SL045044-D-PP
	300	95	700 000	1 550 000	182 000	610	19,5	SL04220-D-PP
240	360	160	1 630 000	3 300 000	385 000	530	56	SL045048-D-PP
	320	95	740 000	1 700 000	195 000	560	21	SL04240-D-PP
260	400	190	2 380 000	4 700 000	530 000	475	84,5	SL045052-D-PP
	340	95	840 000	1 990 000	225 000	520	22,5	SL04260-D-PP
280	420	190	2 600 000	5 200 000	580 000	450	90	SL045056-D-PP
	360	95	870 000	2 120 000	235 000	485	24	SL04280-D-PP
300	460	218	3 000 000	5 800 000	640 000	415	126	SL045060-D-PP
	380	95	900 000	2 250 000	245 000	455	25,5	SL04300-D-PP

medias ► <https://www.schaeffler.de/std/1E48>

- 1) For snap rings WRE.
- 2) For retaining ring to DIN 471.



Dimensions								Mounting dimensions					Snap ring WRE	Retaining ring to DIN 471
d	C	C ₁	D ₁	m	r	t	x	C _{a1} ¹⁾	C _{a2} ²⁾	d ₁	d ₂	d ₃ ¹⁾		
		+0,2			min.			-0,2	-0,2					
170	121	107,2	254	5,2	0,6	2	100	99	97	201	220	282	WRE260	260×5
	79	71,2	226	5,2	0,6	1,8	64	65	61	194	206	250	WRE230	230×5
180	135	118,2	274	5,2	0,6	2	112	110	108	218	239	302	WRE280	280×5
	79	71,2	236	5,2	0,6	1,8	64	65	61	203,5	216	260	WRE240	240×5
190	135	118,2	284	5,2	0,6	2	112	110	108	226	248	312	WRE290	290×5
	79	73,2	254	5,2	0,6	1,8	64	65	63	218	231	282	WRE260	260×5
200	149	128,2	304	6,3	0,6	2	126	120	116	243,5	267	336	WRE310	310×6
	79	73,2	264	5,2	0,6	1,8	64	65	63	227,5	241	292	WRE270	270×5
220	159	138,2	334	6,3	1	2	132	130	126	260	286	366	WRE340	340×6
	94	83,2	294	5,2	1	2	72	75	73	249	264	322	WRE300	300×5
240	159	138,2	354	6,3	1	2	132	130	126	279,5	305	386	WRE360	360×6
	94	83,2	314	6,3	1	2	72	75	71	272	287	346	WRE320	320×6
260	189	162,2	394	6,3	1,1	3	150	154	150	305	336	426	WRE400	400×6
	94	83,2	334	6,3	1	3	75	75	71	293	310	366	WRE340	340×6
280	189	163,2	413	7,3	1,1	3	150	154	149	321	354	453	WRE420	420×7
	94	83,2	354	6,3	1	3	75	75	71	310,5	386	327	WRE360	360×6
300	216	185,2	453	7,3	1,1	3	170	176	171	347	375	493	WRE460	460×7
	94	83,2	374	6,3	1	3	75	75	71	328	346	406	WRE380	380×6



Tapered roller bearings



Matrix for bearing preselection 557

1 Tapered roller bearings 558

1.1	Bearing design	558
1.2	Load carrying capacity	564
1.3	Compensation of angular misalignments	564
1.4	Lubrication	565
1.5	Sealing	566
1.6	Speeds	566
1.7	Noise	566



1.8	Temperature range	567	1.19	Further information	585	
1.9	Cages	567	Product tables			586
1.10	Internal clearance	568		<i>Tapered roller bearings, single row to DIN/ISO</i>	586	
1.11	Dimensions, tolerances	568		<i>Tapered roller bearings, single row to ANSI/ABMA</i>	614	
1.12	Suffixes	573		<i>Tapered roller bearings, matched pairs</i>	632	
1.13	Structure of bearing designation	574		<i>Integral tapered roller bearings</i>	636	
1.14	Dimensioning	575				
1.15	Minimum load	580				
1.16	Design of bearing arrangements	581				
1.17	Mounting and dismounting	584				
1.18	Legal notice regarding data freshness	585				





Matrix for bearing preselection

The matrix gives an overview of the types and design features of tapered roller bearings.

It can be used to make a preliminary assessment of whether a bearing is fundamentally suitable for the envisaged application.

The additional information provided in the product chapter (see column "detailed information") and in the Technical principles must, however, be observed in selection of the bearing.

Design features and suitability			Tapered roller bearings			
			single row	matched pairs	integral tapered roller bearings, fitted in pairs	detailed information
+++ extremely suitable ++ highly suitable + suitable (+) suitable with restrictions – not suitable/not applicable available ✓ available						558
Load carrying capacity	radial		+++	+++	+++	564 1.2
	axial, one direction		+++	+++	+++	564 1.2
	axial, both directions		–	+++	+++	564 1.2
	moments		(+)	(+)	(+)	564 1.2
Compensation of angular misalignments	static		(+)	(+)	(+)	564 1.3
	dynamic		(+)	(+)	(+)	564 1.3
Bearing design	cylindrical bore		✓	✓	✓	558 1.1
	tapered bore		–	–	–	558 1.1
	separable		✓	✓	–	584 1.17
Lubrication	greased		–	–	✓	565 1.4
Sealing	open		✓	✓	–	566 1.5
	non-contact		–	–	–	566 1.5
	contact		–	–	✓	566 1.5
Operating temperature in °C	from to		–30 +120 ¹⁾	–30 +120 ¹⁾	–30 +110	567 1.8
Suitability for	high speeds		+ ²⁾	(+)	(+)	566 1.6 64
	high running accuracy		++	++	++	568 1.11 114
	low-noise running		(+)	(+)	(+)	566 1.7 27
	high rigidity		+++ ³⁾	+++	+++	54
	reduced friction		+	+	+	56
	length compensation within bearing		–	–	–	
	non-locating bearing arrangement		(+) ³⁾	(+)	(+)	139
	locating bearing arrangement		+++	+++	+++	139
X-life bearings			✓	✓	–	559
Bearing bore d in mm	from to		15 360 ⁴⁾⁵⁾	40 260 ⁴⁾	30 80	586
Product tables	from page		586	632	636	



- 1) Where D > 220 mm: +200 °C
- 2) Reduced suitability when mounted in pairs
- 3) For mounting in pairs
- 4) Larger catalogue bearings GL 1
- 5) Bearings to ANSI/ABMA up to d = 673,1 mm

1 Tapered roller bearings



Tapered roller bearings are particularly suitable where:

- high radial loads occur ▶ 558 | 1.1 and ▶ 564 | 1.2
- high axial loads act on one side ▶ 564 | 1.2
- combined loads must be supported (radial and axial forces acting simultaneously) ▶ 564 | 1.2
- precise axial guidance of the shaft is required (locating bearing function)
- the bearing arrangement must have very high axial rigidity
- the bearing position is operated clearance-free or under preload (single bearings are adjusted against each other) ▶ 581 | 1.16
- high running accuracy is required
- the load carrying capacity of angular contact ball bearings is no longer sufficient and the higher speed suitability of angular contact ball bearings is not required ▶ 558 | 1.2
- the bearings are not required to compensate misalignments
- the design objective comprises compact, rigid and economical bearing arrangements with a high load carrying capacity.

For an overview of other product-specific features, see the Matrix for bearing preselection ▶ 557.

Load carrying capacity and speed comparison – single row tapered roller bearings/single row angular contact ball bearings

F_r = radial load
 C_r = basic dynamic load rating
 n_G = limiting speed

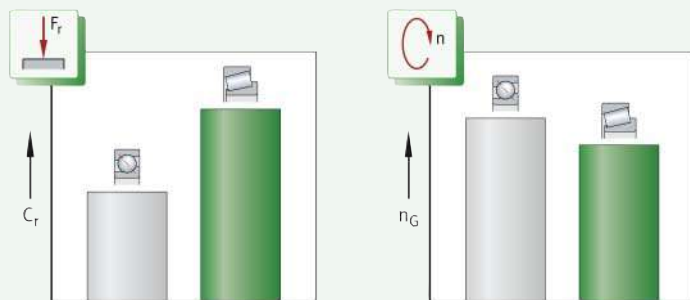

1.1 Bearing design

Design variants

Tapered roller bearings are available in an extensive range of single row and multi-row designs. X-life is the new performance standard for tapered roller bearings and stands for eXtended life ▶ 559. The key designs based on single row tapered roller bearings are:

- single row tapered roller bearings
- matched tapered roller bearings
- integral tapered roller bearings.



Tapered roller bearings are also available in many other designs and sizes, as well as for specific applications, by agreement. For general availability, please contact Schaeffler. An upgrade to X-life performance is available. X-life bearings ▶ TPI 241. Matched tapered roller bearings ▶ TPI 245. Integral tapered roller bearings ▶ TPI 151. Larger catalogue bearings and other bearing designs ▶ GL 1.

Available in metric and inch sizes

Tapered roller bearings are produced in metric and inch sizes.

Classification and designation – bearings in metric and inch sizes



Bearings in metric sizes:

- DIN 720:2008
- ISO 355:2007
- ANSI/ABMA 19.1:2011 (prefix KJ).

Bearings in inch sizes:

- ANSI/ABMA 19.2:2013 (prefix K).

Tapered roller bearings of basic design

🔗 Fundamental design features

Tapered roller bearings are part of the group of radial roller bearings. In contrast to the ball, the roller has a larger contact area perpendicular to the roller axis. As a result, it can transmit higher forces, has greater rigidity and allows smaller rolling element diameters under the same load. The single row and multi-row bearings comprise a ribless outer ring, an inner ring with two ribs of different heights and a cage ▶ 559 | 2, ▶ 561 | 5. The cage contains truncated conical rollers. The roller and cage assembly together with the inner ring forms a unit. The low rib retains, in conjunction with the cage, the rollers on the inner ring raceway; the high rib supports the axial force component arising from the tapered form of the rollers. While the tapered rollers roll on the raceways, they slide on the higher rib of the inner ring. The projected lines of contact of the tapered rollers intersect the projected raceways of the inner and outer ring at a point on the bearing axis ▶ 559 | 2. As a result of this geometrical characteristic, tapered roller bearings are highly suitable for supporting combined loads. This also prevents any kinematic forced slippage at the rolling contact.

🔗 The high dimensional and geometrical accuracy of the rollers reduces running noise and vibrations

Due to the dimensional and geometrical accuracy of the tapered rollers, the rolling elements in a roller set are subjected to virtually the same proportion of load in the load range. In operation, this leads to low-noise and low-vibration running, as well as a high adjustment accuracy.



Single row tapered roller bearing: the apex points of the tapered surfaces meet at a point on the bearing axis

F_r = radial load

F_a = axial load

R = roller cone apex

α = nominal contact angle

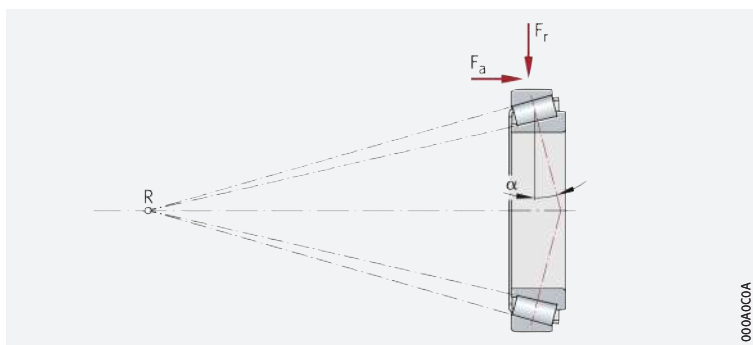

X-life premium quality

X-life

Single row tapered roller bearings are available in numerous series and dimensions as X-life bearings. These bearings exhibit considerably higher performance than comparable tapered roller bearings without X-life characteristics ▶ 560 | 3. This is achieved, in part, by superior ring materials and optimised contact geometry between roller and raceway, as well as between roller and rib. In combination with an increased surface quality, this leads to improved lubricant film formation.

Increased customer benefits due to X-life

Advantages

These technical enhancements offer a range of advantages, such as:

- up to 20 % higher basic dynamic load ratings C_r > 560 | 3
- a higher running accuracy and smooth running
- running with reduced friction and greater energy efficiency (reduction in friction up to 50 %, in the case of tapered roller bearings with a steep taper, up to 75 %)
- lower heat generation in the bearing
- higher limiting speeds
- lower lubricant consumption and therefore longer maintenance intervals if relubrication is carried out
- a measurably longer operating life of the bearings > 560 | 4
- high reliability and operational security
- lower overall operating costs
- compact, environmentally-friendly bearing arrangements.

Lower operating costs, higher machine availability

In conclusion, these advantages improve the overall cost-efficiency of the bearing position significantly and thus bring about a sustainable increase in the efficiency of the machine and equipment.

Suffix XL

X-life tapered roller bearings include the suffix XL in the designation > 573 | 1.12.

3 Comparison of basic dynamic load rating C_r of X-life tapered roller bearings with bearings without X-life performance

C_r = basic dynamic load rating

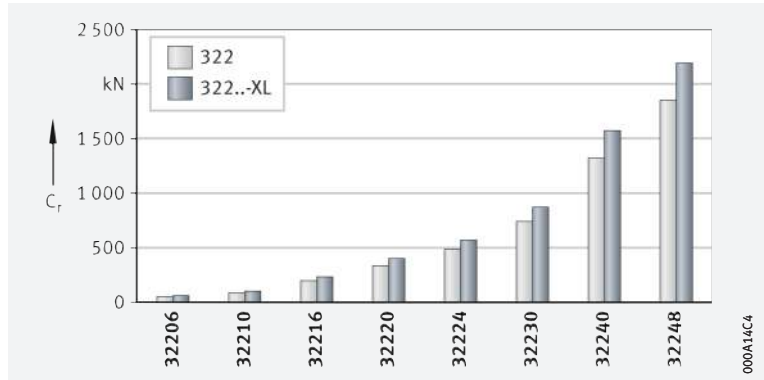

4 Fatigue running time in Weibull diagram – comparison of X-life tapered roller bearings with bearings without X-life performance

- ① Probability of failure
- ② Running time in hours

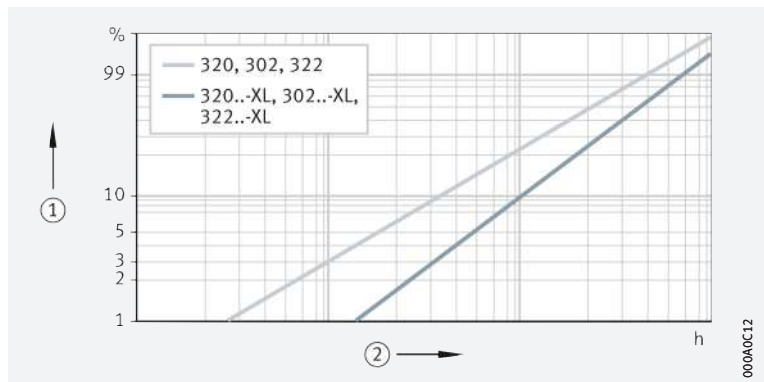

Areas of application

Due to their special technical features, X-life tapered roller bearings are highly suitable for bearing arrangements in:

- mobile hydraulics (axial piston and orbital motors)
- tractors (wheel bearings and gearboxes)
- vertical mills (grinding rolls)
- hot and cold rolling mills (work rolls in roll stands)
- applications for oil and gas extraction
- offshore and onshore wind turbines (gearboxes)
- construction machinery (road rollers, drill head bearings).



X-life indicates a high product performance density and thus a particularly significant benefit to the customer. Further information on X-life ▶ 10 and ▶ □ TPI 241.

Single row tapered roller bearings

Optimised product characteristics give a sustainable improvement in operating behaviour

Tapered roller bearings are individual, single row bearings of open design which, for technical reasons, are always adjusted against a second tapered roller bearing in a mirror image arrangement ▶ 561 | □ 5.

The bearings are designed such that they reliably cover the extensive demands in relation to generally common requirements.

For example, in order to improve the lubricant film formation and running characteristics, the sliding surfaces on the guidance rib of the inner ring, as well as the end faces and contact profile of the rollers, have been optimised ▶ 559. In addition, the high production accuracy allows the bearings to be adjusted against each other with high functional security. This in turn leads to improved operating characteristics and thus to a higher operational reliability. Tapered roller bearings are not self-retaining. As a result, the inner ring with the roller and cage assembly can be mounted separately from the outer ring. This gives simplified mounting of the bearings.



Single row tapered roller bearing

F_r = radial load

F_a = axial load

α = nominal contact angle

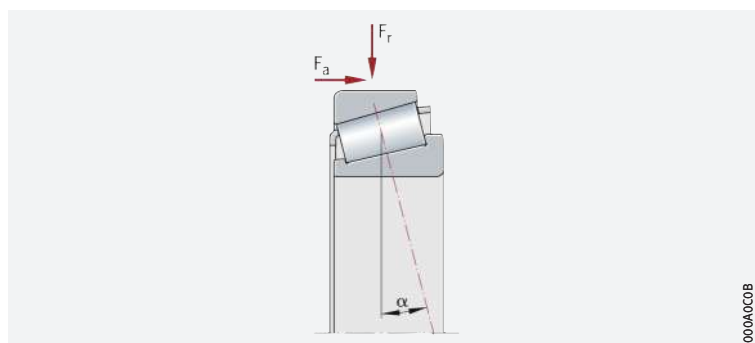

000A0C0B

Matched tapered roller bearings

If the load carrying capacity of a bearing is not sufficient or the shaft is to be guided in both directions with a specific axial clearance, then ready-to-fit, matched bearing sets are available. Matched tapered roller bearings are essentially available in three arrangements comprising an X, O and tandem arrangement.



 **6**
Matched tapered rolling bearing pairs in tandem, X and O arrangement, load directions, contact lines

F_r = radial load
 F_a = axial load

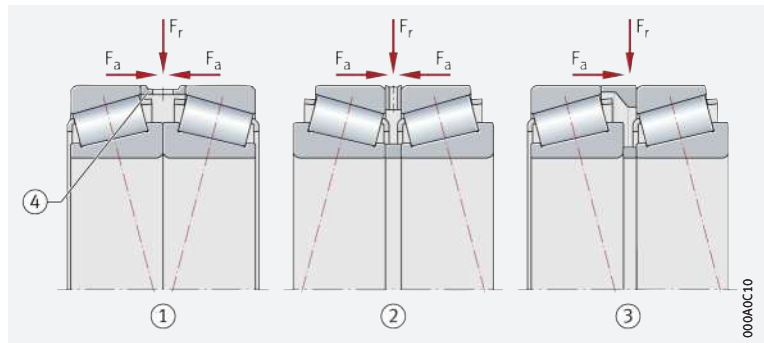

- ① X arrangement
- ② O arrangement
- ③ Tandem arrangement
- ④ Fit ring



X arrangement

For bearing sets in an X arrangement, the contact lines converge relative to the bearing axis  562 |  6. Axial forces occur from both directions, but are always only supported by one bearing. The X arrangement is of simple design and the most frequently used arrangement of matched tapered roller bearings fitted in pairs.



O arrangement

For bearing sets in an O arrangement, the contact lines diverge relative to the bearing axis  562 |  6. Axial forces occur from both directions, but are always only supported by one bearing. The support base is at its largest in the O arrangement, which is beneficial if this component with small bearing spacing must be guided with the smallest possible tilting clearance, or tilting forces must be supported. Bearing arrangements in an O arrangement are relatively rigid and can also support loads resulting from tilting moments.

Tandem arrangement

For bearing sets in a tandem arrangement, the contact lines run parallel to each other. In contrast to an X and O arrangement, the tandem arrangement can only support axial force in one direction. This bearing pair is usually adjusted against another tapered roller bearing, which supports axial forces in the opposite direction.



The product tables  632 |  contain only a few examples of matched tapered roller bearing sets in an X arrangement for reference purposes. Other matched tapered roller bearing sets are available in an X arrangement by agreement. Further information on “Matched tapered roller bearings”  TPI 245.

Advantages of matched bearing sets

Matched bearing pairs in an O or X arrangement provide an economical solution to various bearing arrangement problems due, for example, to:

- their ability to support high radial loads as well as axial loads in both directions
- the simplified mounting of bearings, as the insertion of fit rings is no longer required and mounting defects are thus avoided
- the precise axial guidance of the shaft; the axial clearance of the bearing pair is already defined in bearing production
- simple lubrication; the lubricant can be easily fed to the rolling system by means of lubrication holes in the fit ring.

Ordering and designation system

In order to simplify the ordering process, the ordering designation has been modified for matched tapered roller bearings fitted in pairs:

- The first module letter D = 2 (duplex) represents the number of bearings
- The second module letter represents the bearing arrangement:
 - B = O arrangement – Back to Back
 - F = X arrangement – Face to Face
 - T = tandem arrangement
- Where necessary (special design), a third module letter is added as a continuous counter for describing a variant. Example: A, B, ... = different set width, variant of intermediate ring design
- The axial internal clearance is indicated explicitly in the designation. For example, A80-120 means that the axial internal clearance of the unmounted bearing pair (delivered condition) is between 80 μm and 120 μm . Ordering example \blacktriangleright 575 | \square 15.



The number of bearing pairs must be stated when ordering matched tapered roller bearings.

Integral tapered roller bearings (JKOS) – fitted in pairs

Integral tapered roller bearings are ready-to-fit bearing units, which are greased, sealed on one side and predominantly mounted in pairs in an O arrangement \blacktriangleright 563 | \square 7. The bearings are not separable.

The precise axial internal clearance is not achieved by adjusting the bearings, but is set automatically when the recommended bearing seat tolerances are observed. As a result, there is no need to adjust the bearings against each other in the manner normally required. When integral tapered roller bearings are mounted in pairs, a slot is formed on the outer ring for the retaining ring (snap ring BR). Schaeffler integral tapered roller bearings are interchangeable with each other.



When ordering, please always state the number of single bearings and not the number of bearing pairs. The snap ring must be ordered separately, for example:

- 2 tapered roller bearings JKOS080-A \blacktriangleright 586 | \square
- 1 snap ring BR125.

The bearings are predominantly fitted in pairs

There is no need to set the axial internal clearance



7
Paired integral tapered roller bearing, load directions

F_r = radial load

F_a = axial load

① Integral tapered roller bearings (JKOS), fitted in pairs in an O arrangement, sealed, clearance preset

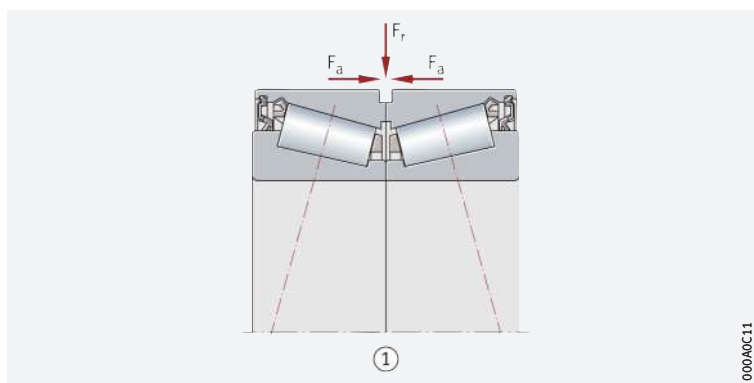

1.2 Load carrying capacity

☞ *Capable of supporting axial loads in one direction and radial loads*

☞ *The larger the contact angle, the higher the axial load carrying capacity*

Bearings of basic design

Single row tapered roller bearings can support axial loads in one direction and high radial loads ▶ 559 | 2 and ▶ 561 | 5. However, they must always be axially adjusted against a second bearing fitted in a mirror image arrangement. This bearing combination is then fitted in an O or X arrangement.

The axial load carrying capacity of the bearings is dependent on the nominal contact angle α ▶ 559 | 2. The greater this angle, the higher the axial load to which the bearing can be subjected. The size of the contact angle – and thus the load carrying capacity of the bearing – is indicated by the value e in the product tables ▶ 586 | 11. The nominal contact angle α in most bearing series is between 10° and 20° . In special series, α is approximately 28° to 30° . Bearings of series 313, 323..-B, T5ED and T7FC have a very high axial load carrying capacity due to their particularly large contact angle.

Basic load rating and fatigue limit load for bearing pairs comprising single bearings

If two bearings of the same size and design are fitted immediately adjacent to each other in an O or X arrangement, the basic dynamic load rating C_r , the basic static load rating C_{Or} and the fatigue limit load C_{ur} of the bearing pair are as follows:

- $C_r = 1,715 \cdot C_{r \text{ single bearing}}$
- $C_{Or} = 2 \cdot C_{Or \text{ single bearing}}$
- $C_{ur} = 2 \cdot C_{ur \text{ single bearing}}$

Values for single bearings in the product tables ▶ 586 | 11, ▶ 614 | 11.

Matched bearings

☞ *Capable of supporting radial loads, axial loads in both directions and moment loads*

Matched tapered roller bearings support higher radial forces than single row tapered roller bearings. In X and O arrangements, axial forces and moment loads are supported in both directions. The tandem arrangement can only support axial forces in one direction.

Basic load rating and fatigue limit load for matched bearings

For matched bearing pairs of design DF, the basic load ratings and fatigue limit loads are given in the dimension tables ▶ 632 | 11.

Integral tapered roller bearings – fitted in pairs

☞ *Capable of supporting axial loads in both directions and radial loads*

Single row integral tapered roller bearings fitted in pairs in an O arrangement support high axial loads in both directions and high radial loads ▶ 563 | 7.

1.3 Compensation of angular misalignments

☞ *Compensation of angular misalignments possible*

The modified line contact between the tapered rollers and the raceways ensures optimum stress distribution at the contact points and prevents stress increases at the edges. As a result, the bearings can tolerate certain angular misalignments and give better support of moment loads ▶ 565 | 8.

8

Uniform load distribution
due to optimised roller and
raceway profile

F = load on the roller

- ① Straight profile
- ② Logarithmic profile

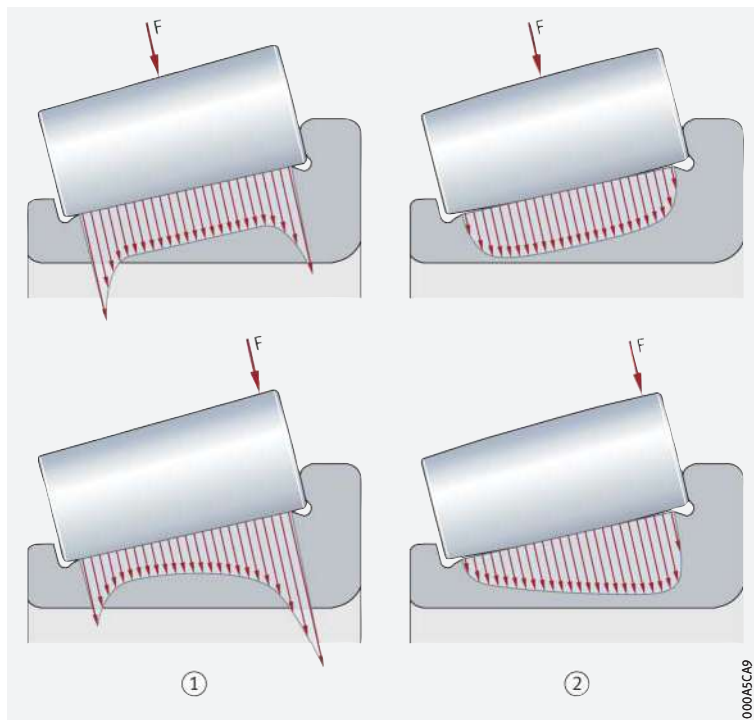

Permissible angular misalignment



If the load ratio $P/C_{0r} \leq 0,2$, the tilting of the bearing rings relative to each other must not exceed 4 angular minutes. This is, however, subject to the position of the shaft and housing axis remaining constant (no dynamic movements).



If larger loads/misalignments or dynamic angular defects are present, please consult Schaeffler.

1.4 Lubrication

Oil or grease lubrication
is possible

Compatibility
with plastic cages

Observe oil change
intervals

Usually maintenance-free
due to initial greasing

Single row and matched tapered roller bearings

Single row and matched tapered roller bearings are not greased. These bearings must be lubricated with oil or grease.

When using bearings with plastic cages, compatibility between the lubricant and the cage material must be ensured if synthetic oils, lubricating greases with a synthetic oil base or lubricants containing a high proportion of EP additives are used.

Aged oil and additives in the oil can impair the operating life of plastics at high temperatures. As a result, stipulated oil change intervals must be strictly observed.

Integral tapered roller bearings

Integral tapered roller bearings are supplied already greased with a quality grease to DIN 51825. The grease filling is measured such that these bearings are maintenance-free during their operating lives in most applications.

1.5 Sealing

 *Provide seals in the adjacent construction*

Single row and matched tapered roller bearings

Single row and matched tapered roller bearings are not sealed, i.e. sealing of the bearing position must be carried out in the adjacent construction. This must reliably prevent:

- moisture and contaminants from entering the bearing
- the egress of lubricant from the bearing position.

Integral tapered roller bearings

Integral tapered roller bearings are sealed on one side with a contact seal (lip seal).

1.6 Speeds

 *Limiting speeds and reference speeds in the product tables*

The product tables give two speeds for most bearings :

- the kinematic limiting speed n_G
- the thermal speed rating $n_{\theta r}$.

Limiting speeds



The limiting speed n_G is the kinematically permissible speed of the bearing. Even under favourable mounting and operating conditions, this value should not be exceeded without prior consultation with Schaeffler 64.

Reference speeds

 *$n_{\theta r}$ is used to calculate n_{θ}*

The thermal speed rating $n_{\theta r}$ is not an application-oriented speed limit, but is a calculated ancillary value for determining the thermally safe operating speed n_{θ} 64.

 *Bearings with contact seals*

For bearings with contact seals, no reference speeds are defined in accordance with DIN ISO 15312:2004. As a result, only the limiting speed n_G is given in the product tables for these bearings.

Speeds for matched bearings fitted in pairs

 *Observing the thermal balance*

For matched bearing pairs, the limiting speeds n_G given in the product tables are permissible if the less favourable thermal balance of the bearing pair is taken into consideration in the operating conditions.

1.7 Noise

The Schaeffler Noise Index (SGI) has been developed as a new feature for comparing the noise level of different bearing types and series. As a result, a noise evaluation of rolling bearings can now be carried out for the first time.

Schaeffler Noise Index

The SGI value is based on the maximum permissible noise level of a bearing in accordance with internal standards, which is calculated on the basis of ISO 15242. In order that different bearing types and series can be compared, the SGI value is plotted against the basic static load rating C_0 .

This permits direct comparisons between bearings with the same load carrying capacity. The upper limit value is given in each of the diagrams. This means that the average noise level of the bearings is lower than illustrated in the diagram.

! The Schaeffler Noise Index is an additional performance characteristic in the selection of bearings for noise-sensitive applications. The specific suitability of a bearing for an application in terms of installation space, load carrying capacity or speed limit for example, must be checked independently of this.

👁 The Noise Index is currently available for the main series. Additional series will be updated and introduced in subsequent publications.

Further information:

■ **medias** ► <https://medias.schaeffler.com>.

9 Schaeffler Noise Index for tapered roller bearings

SGI = Schaeffler Noise Index

C_0 = basic static load rating

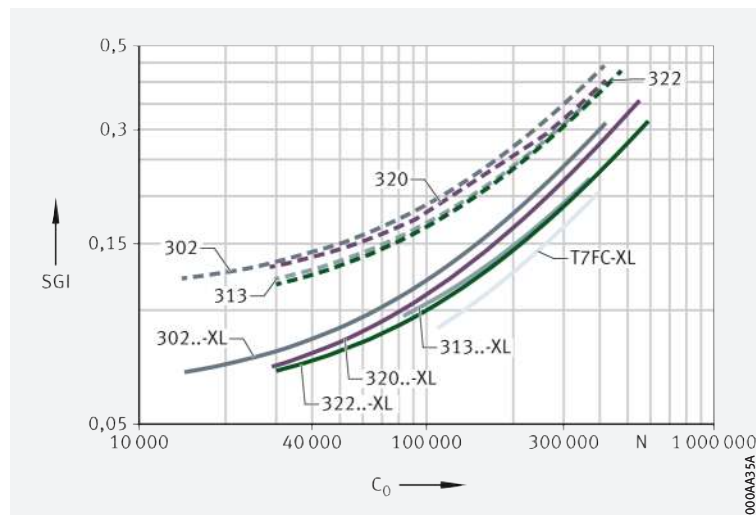

1.8 Temperature range

👁 Limiting values

The operating temperature of the bearings is limited by:

- the dimensional stability of the bearing rings and tapered rollers
- the cage
- the lubricant
- the seals.

Possible operating temperatures of tapered roller bearings ► 567 | 1.



Permissible temperature ranges

Operating temperature	Open tapered roller bearings		Sealed tapered roller bearings
	$D \leq 220$ mm, -30 °C to +120 °C	$D > 220$ mm, -30 °C to +200 °C	-30 °C to +110 °C, limited by the lubricating grease and seal material



In the event of anticipated temperatures which lie outside the stated values, please contact Schaeffler.

1.9 Cages

👁 Sheet steel cages are used as standard

👁 Cages for JK0S

Open tapered roller bearings have sheet steel cages. Plastic cages are available by agreement.

Integral tapered roller bearings have cages made from glass fibre reinforced polyamide PA66.



For high continuous temperatures and applications with difficult operating conditions, bearings with sheet steel cages should be used. If there is any uncertainty regarding cage suitability, please consult Schaeffler.

1.10 Internal clearance

For tapered roller bearings, the axial internal clearance s_a is a characteristic value. This is the result of mounting the bearing against a second tapered roller bearing ► 568 | 10.

 10
Axial internal clearance
 s_a = axial internal clearance

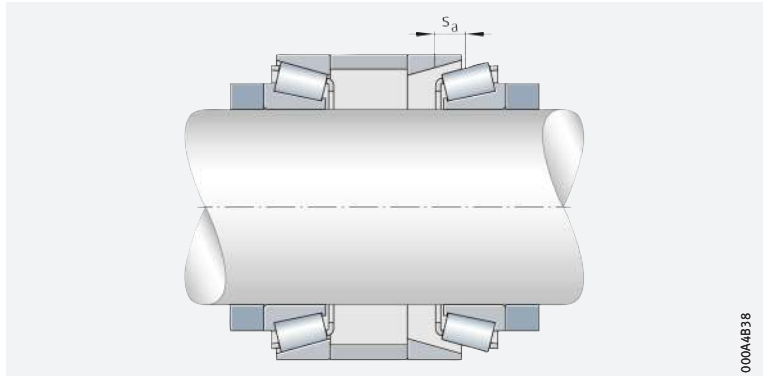

 *Indicating the axial internal clearance*

The axial internal clearance is indicated explicitly in the designation. Ordering example ► 575 | 15.

Matched tapered roller bearing sets

Simple mounting of the bearing sets in the mounting position is achieved by precise matching of the intermediate ring to the required geometric axial internal clearance. As a result, ready-to-fit, matched bearing sets are made available by Schaeffler. This offers high economical and technical advantages such as:

- Uncomplicated mounting: mounting defects are, for example, avoided by the intermediate ring, which is supplied already matched
- Knowledge and inclusion of the axial deflection of the bearings, as well as highly developed measurement methods, guarantee a precise design of the axial internal clearance. This ensures precise axial guidance of the shaft
- Simple maintenance and high operational reliability are achieved by means of design elements, lubrication grooves and holes in the intermediate ring.

1.11 Dimensions, tolerances

Dimension standards – bearings in metric sizes



The main dimensions of bearings in metric sizes correspond to ISO 355:2007 and DIN 720:2008. Bearings in metric sizes with the prefix KJ correspond to ANSI/ABMA 19.1:2011.

Chamfer dimensions

Tapered roller bearings in metric sizes

The limiting dimensions for the chamfer dimensions of metric tapered roller bearings to DIN/ISO correspond to ISO 582:1995. Overview and limiting values for metric tapered roller bearings to DIN/ISO ▶ 137 | 30.

Minimum chamfer dimensions for metric tapered roller bearings to ANSI/ABMA with the prefix KJ correspond to ANSI/ABMA 19.1:2011. The values are given in the product tables.

Bearings in inch sizes to ANSI/ABMA



Minimum chamfer dimensions r_{min} for bearings in inch sizes correspond to ANSI/ABMA 19.2:2013. The values are given in the product tables ▶ 614 | 30.

Tolerances



All tapered roller bearings to DIN 720, ISO 355 and integral tapered roller bearings have the tolerance class Normal to ISO 492:2014. In contrast to the standard, X-life bearings achieve improved radial runout values t_{Kia} and t_{Kea} , in addition to dedicated axial runout values t_{Sia} ▶ 570 | 11. Inner ring tolerances ▶ 569 | 2, outer ring tolerances ▶ 569 | 3, width tolerances ▶ 570 | 4. This excludes bearings of series 320, 329, 330, 331, 332 for $d \leq 200$ mm: these have the tolerance class 6X ▶ 570. The width tolerances $t_{\Delta Ts}$ of the T7FC series with the suffix XL correspond to the tolerance class 6X in accordance with ISO 492:2014 ▶ 570 | 5.



Inner ring tolerances, tolerance class Normal

Tolerance symbols ▶ 115 | 6

U = upper limit deviation

L = lower limit deviation

t_{Sia} = axial runout to Schaeffler standard ▶ 570 | 11

Nominal bore diameter		Bore deviation		Variation		Radial runout		Axial runout
						ISO 492	X-life	X-life
d	mm	$t_{\Delta dmp}$		t_{Vdsp}	t_{Vdmp}	t_{Kia}	t_{Kia}	t_{Sia}
over	incl.	U	L	μm max.	μm max.	μm max.	μm max.	μm max.
10	18	0	-12	12	9	15	7	10
18	30	0	-12	12	9	18	8	13
30	50	0	-12	12	9	20	9	13
50	80	0	-15	15	11	25	10	15
80	120	0	-20	20	15	30	13	18
120	180	0	-25	25	19	35	19	20
180	250	0	-30	30	23	50	24	25
250	315	0	-35	35	26	60	28	28
315	400	0	-40	40	30	70	33	35



Outer ring tolerances, tolerance class Normal

Tolerance symbols ▶ 115 | 6

U = upper limit deviation

L = lower limit deviation

Nominal outside diameter		Deviation of outside diameter		Variation		Radial runout	
						ISO 492	X-life
D	mm	$t_{\Delta Dmp}$		t_{VDsp}	t_{VDmp}	t_{Kea}	t_{Kea}
over	incl.	U	L	μm max.	μm max.	μm max.	μm max.
18	30	0	-12	12	9	18	9
30	50	0	-14	14	11	20	10
50	80	0	-16	16	12	25	13
80	120	0	-18	18	14	35	16
120	150	0	-20	20	15	40	19
150	180	0	-25	25	19	45	21
180	250	0	-30	30	23	50	25
250	315	0	-35	35	26	60	30
315	400	0	-40	40	30	70	34
400	500	0	-45	45	34	80	40
500	630	0	-50	60	38	100	46



4

Width tolerances,
tolerance class Normal

Tolerance symbols > 115 | 6
U = upper limit deviation
L = lower limit deviation

Nominal bore diameter		Deviation of inner ring width				Deviation of outer ring width				Width deviation			
d mm		$t_{\Delta Bs}$ μm		$t_{\Delta Cs}$ μm		$t_{\Delta Ts}$ μm		$t_{\Delta T1s}$ μm		$t_{\Delta T2s}$ μm			
over	incl.	U	L	U	L	U	L	U	L	U	L		
10	18	0	-120	0	-120	+200	0	+100	0	+100	0		
18	30	0	-120	0	-120	+200	0	+100	0	+100	0		
30	50	0	-120	0	-120	+200	0	+100	0	+100	0		
50	80	0	-150	0	-150	+200	0	+100	0	+100	0		
80	120	0	-200	0	-200	+200	-200	+100	-100	+100	-100		
120	180	0	-250	0	-250	+350	-250	+150	-150	+200	-100		
180	250	0	-300	0	-300	+350	-250	+150	-150	+200	-100		
250	315	0	-350	0	-350	+350	-250	+150	-150	+200	-100		
315	400	0	-400	0	-400	+400	-400	+200	-200	+200	-200		

11

Axial and radial runout
on the drawing

D = outside diameter
d = bearing bore

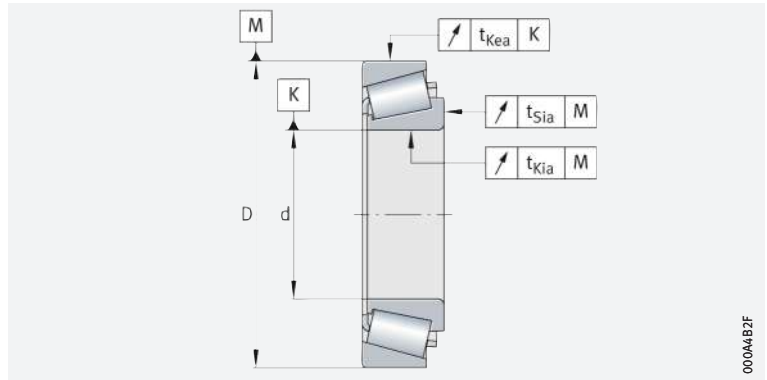

Series 320, 329, 330, 331, 332 for $d \leq 200$ mm and bearings with the prefix KJ

Bearings 320, 329, 330, 331, 332 for $d \leq 200$ mm and bearings with the prefix KJ have dimensional and running tolerances to the tolerance class Normal, but have restricted width tolerances to tolerance class 6X in accordance with ISO 492:2014 > 570 | 5; inner ring tolerances > 569 | 2, outer ring tolerances > 569 | 3.

5

Width tolerances,
tolerance class 6X

Tolerance symbols > 115 | 6
U = upper limit deviation
L = lower limit deviation

Nominal bore diameter		Deviation of inner ring width				Deviation of outer ring width				Width deviation			
d mm		$t_{\Delta Bs}$ μm		$t_{\Delta Cs}$ μm		$t_{\Delta Ts}$ μm		$t_{\Delta T1s}$ μm		$t_{\Delta T2s}$ μm			
over	incl.	U	L	U	L	U	L	U	L	U	L		
10	18	0	-50	0	-100	+100	0	+50	0	+50	0		
18	30	0	-50	0	-100	+100	0	+50	0	+50	0		
30	50	0	-50	0	-100	+100	0	+50	0	+50	0		
50	80	0	-50	0	-100	+100	0	+50	0	+50	0		
80	120	0	-50	0	-100	+100	0	+50	0	+50	0		
120	180	0	-50	0	-100	+150	0	+50	0	+100	0		
180	200	0	-50	0	-100	+150	0	+50	0	+100	0		

Restricted tolerances to tolerance class 5



Tapered roller bearings are also available by agreement with restricted tolerances to tolerance class 5 in accordance with ISO 492:2014; inner ring tolerances ▶ 571 | 6, outer ring tolerances ▶ 571 | 7, width tolerances ▶ 571 | 8.

6

Restricted inner ring tolerances, tolerance class 5

Tolerance symbols ▶ 115 | 6

U = upper limit deviation

L = lower limit deviation

Nominal bore diameter		Bore deviation		Variation		Radial runout	Axial runout of lateral face
d		$t_{\Delta dmp}$		t_{VDsp}	t_{VDmp}	t_{kia}	t_{sd}
mm		μm		μm	μm	μm	μm
over	incl.	U	L	max.	max.	max.	max.
10	18	0	-7	5	5	5	7
18	30	0	-8	6	5	5	8
30	50	0	-10	8	5	6	8
50	80	0	-12	9	6	7	8
80	120	0	-15	11	8	8	9
120	180	0	-18	14	9	11	10
180	250	0	-22	17	11	13	11
250	315	0	-25	19	13	13	13
315	400	0	-30	23	15	15	15

7

Restricted outer ring tolerances, tolerance class 5

Tolerance symbols ▶ 115 | 6

U = upper limit deviation

L = lower limit deviation

Nominal outside diameter		Deviation of outside diameter		Variation		Radial runout	Axial runout of lateral face
D		$t_{\Delta Dmp}$		t_{VDsp}	t_{VDmp}	t_{kea}	t_{si}
mm		μm		μm	μm	μm	μm
over	incl.	U	L	max.	max.	max.	max.
18	30	0	-8	6	5	6	4
30	50	0	-9	7	5	7	4
50	80	0	-11	8	6	8	4
80	120	0	-13	10	7	10	4,5
120	150	0	-15	11	8	11	5
150	180	0	-18	14	9	13	5
180	250	0	-20	15	10	15	5,5
250	315	0	-25	19	13	18	6,5
315	400	0	-28	22	14	20	6,5
400	500	0	-33	26	17	24	8,5
500	630	0	-38	30	20	30	10

8

Width tolerances, tolerance class 5

Tolerance symbols ▶ 115 | 6

U = upper limit deviation

L = lower limit deviation

Nominal bore diameter		Deviation of inner ring width		Deviation of outer ring width		Width deviation					
d		$t_{\Delta Bs}$		$t_{\Delta Cs}$		$t_{\Delta Ts}$		$t_{\Delta T1s}$		$t_{\Delta T2s}$	
mm		μm		μm		μm		μm		μm	
over	incl.	U	L	U	L	U	L	U	L	U	L
10	18	0	-200	0	-200	+200	-200	+100	-100	+100	-100
18	30	0	-200	0	-200	+200	-200	+100	-100	+100	-100
30	50	0	-240	0	-240	+200	-200	+100	-100	+100	-100
50	80	0	-300	0	-300	+200	-200	+100	-100	+100	-100
80	120	0	-400	0	-400	+200	-200	+100	-100	+100	-100
120	180	0	-500	0	-500	+350	-250	+150	-150	+200	-100
180	250	0	-600	0	-600	+350	-250	+150	-150	+200	-100
250	315	0	-700	0	-700	+350	-250	+150	-150	+200	-100
315	400	0	-800	0	-800	+400	-400	+200	-200	+200	-200



Total width tolerance of matched bearings



The tolerance for the total width 2T of matched bearing sets of design DF is determined from the axial internal clearance and the deviations of the width $t_{\Delta Ts}$ of the single bearings. The tolerance for the total width 2B is determined from the deviations of the inner ring width $t_{\Delta Bs}$ of the single bearings ▶ 570 | 4.

Bearings in inch sizes to ANSI/ABMA



Tapered roller bearings with the prefix K are manufactured as standard to the following tables. The values in the tables meet the requirements for normal tolerances in accordance with ANSI/ABMA 19.2:2013 and, in some cases, exceed these by a considerable margin.

Exception: bearings with the prefix KJ correspond to ISO 492:2014. The bore and outside diameters of bearings in inch sizes have plus tolerances; inner ring tolerances ▶ 572 | 9, outer ring tolerances ▶ 572 | 10, width tolerances ▶ 573 | 11.



9 Inner ring tolerances, bearings in inch sizes

Tolerance symbols ▶ 115 | 6
U = upper limit deviation
L = lower limit deviation
 t_{Sia} = axial runout to Schaeffler standard ▶ 570 | 11

Nominal bore diameter		Bore deviation		Radial runout		Axial runout
		$t_{\Delta dmp}$		According to standard	X-life	X-life
d		μm		t_{Kia}	t_{Kia}	t_{Sia}
over	incl.	U	L	μm	μm	μm
				max.	max.	max.
10	18	+12	0	15	7	10
18	30	+12	0	18	8	13
30	50	+12	0	20	9	13
50	80	+12	0	25	10	15
80	120	+25	0	30	13	18
120	180	+25	0	35	19	20
180	250	+25	0	50	24	25
250	304,8	+25	0	50	28	28
304,8	315	+50	0	50	28	28
315	400	+50	0	50	33	35
400	500	+50	0	50	39	38
500	609,6	+50	0	50	45	43
609,6	800	+75	0	75	54	–



10 Outer ring tolerances, bearings in inch sizes

Tolerance symbols ▶ 115 | 6
U = upper limit deviation
L = lower limit deviation

Nominal outside diameter		Bore deviation		Radial runout	
D		$t_{\Delta Dmp}$		According to standard	X-life
mm		μm		t_{Kea}	t_{Kea}
over	incl.	U	L	μm	μm
				max.	max.
18	30	+25	0	18	9
30	50	+25	0	20	10
50	80	+25	0	25	13
80	120	+25	0	35	16
120	150	+25	0	40	19
150	180	+25	0	45	21
180	250	+25	0	50	25
250	304,8	+25	0	50	29
304,8	609,6	+50	0	50	45
609,6	800	+75	0	75	54

11

Width tolerances, bearings in inch sizes

Tolerance symbols ▶ 115 | 6

U = upper limit deviation

L = lower limit deviation

Nominal bore diameter		Deviation of inner ring width		Deviation of outer ring width		Width deviation	
d		$t_{\Delta B_s}$		$t_{\Delta C_s}$		$t_{\Delta T_s}$	
mm		μm		μm		μm	
over	incl.	U	L	U	L	U	L
10	50	0	-120	0	-120	+200	0
50	80	0	-150	0	-150	+200	0
80	101,6	0	-200	0	-200	+200	0
101,6	120	0	-200	0	-200	+350	-250
120	180	0	-250	0	-250	+350	-250
180	304,8	0	-250	0	-250	+350	-250
304,8	800	0	-250	0	-250	+375	-375

1.12 Suffixes

For a description of the suffixes used in this chapter ▶ 573 | 12 and **medias** interchange ▶ <https://www.schaeffler.de/std/1D52>.

12

Suffixes and corresponding descriptions

Suffix	Description of suffix
A	Modified internal construction (excluding bearings to ANSI/ABMA)
B	Increased contact angle (for bearings to DIN)
DF-A... ..	Two tapered roller bearings matched in an X arrangement, with an intermediate ring between the outer rings. Axial internal clearance between .. and .. in μm
X	External dimensions matched to international standards (for bearings to DIN)
XL	X-life



Tapered roller bearings for special applications



Special tapered roller bearings are available for applications where tapered roller bearing arrangements are used under very difficult operating conditions, for example at high operating temperatures or with heavily contaminated lubricating oil. In such cases, please consult Schaeffler. Suffixes for special designs ▶ 573 | 13.

13

Special designs, available by agreement

Suffix	Description of suffix
DB-A... ..	Two tapered roller bearings matched in an O arrangement, with an intermediate ring between the outer rings and the inner rings, axial internal clearance between .. and .. in μm
DT	Two tapered roller bearings matched in a tandem arrangement, with an intermediate ring between the outer rings
P5	Bearing in tolerance class 5



Other special designs with suffixes are available by agreement, such as for:

- dimensional stabilisation
- special heat treatment
- special materials
- tapered roller bearings with reduced friction
- tolerance classes
- restricted width tolerances.

1.13 Structure of bearing designation

Examples of composition of bearing designation

The designation of bearings follows a set model. Examples ▶ 574 | 12 to ▶ 575 | 16. The composition of designations is subject to DIN 623-1:1993 ▶ 102 | 10, DIN 720:2008 ▶ 101 | 9, ISO 10317:2008, ISO 355:2007 ▶ 101 | 8, ANSI/ABMA 19.1:2011 and ANSI/ABMA 19.2:2013.

12
Single row tapered roller bearing, metric, to DIN 623-1:1993, DIN 720:2008: designation structure

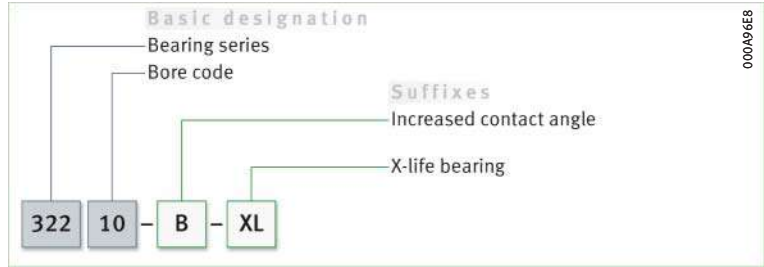

13
Single row tapered roller bearing, metric, to ISO 10317:2008, ISO 355:2007: designation structure

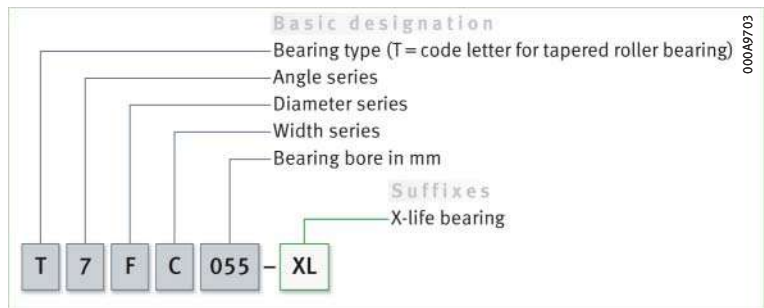

14
Single row tapered roller bearing, metric, to ANSI/ABMA 19.1:2011; inch sizes, to ANSI/ABMA 19.2:2013: designation structure

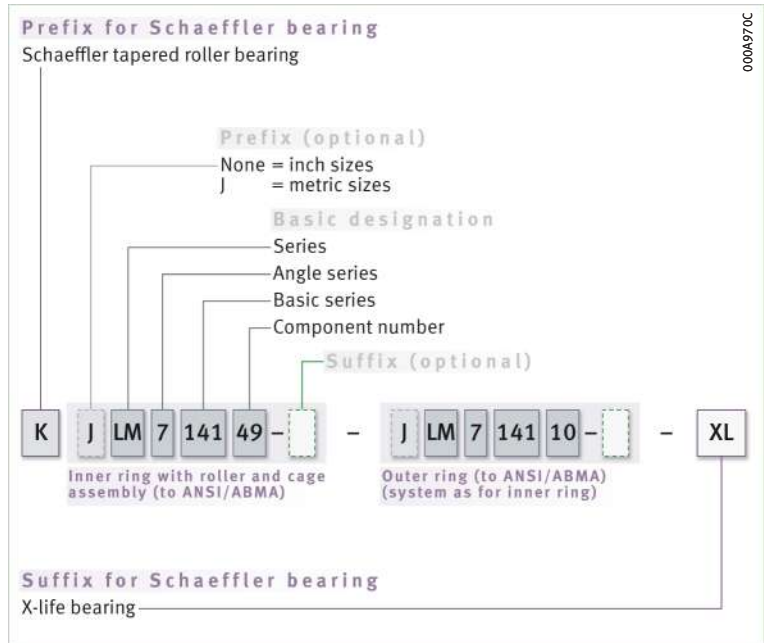

15
Matched tapered roller bearing pair: designation structure

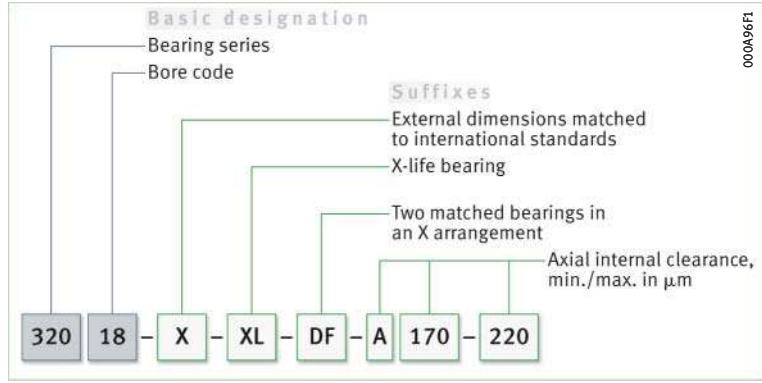

16
Integral tapered roller bearing: designation structure

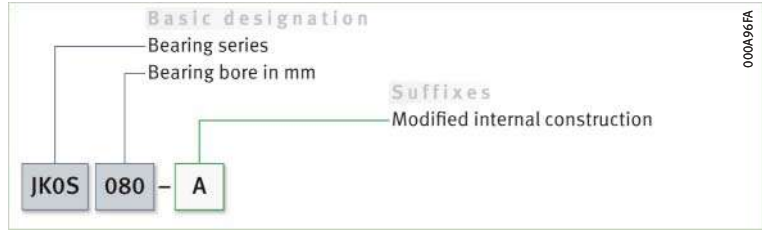

1.14 Dimensioning

$P = F_r$ under purely radial load of constant magnitude and direction

P is a substitute force for combined load

$F_a/F_r \leq e$ or $F_a/F_r > e$

Single bearings and JK0S bearings

Equivalent dynamic bearing load

The basic rating life equation $L = (C_r/P)^P$ used in the dimensioning of radial bearings under dynamic load assumes a radial load P of constant magnitude. If the bearing is subjected to purely radial load, the radial load F_r is used directly in the rating life equation for P ($P = F_r$).

If this condition is not met, a constant radial force must first be determined for the rating life calculation that (in relation to the rating life) represents an equivalent load. This force is known as the equivalent dynamic bearing load P .

The calculation of P is dependent on the load ratio F_a/F_r and the factor e .

For single bearings under dynamic load and integral tapered roller bearings \blacktriangleright 575 | f_1 1 and \blacktriangleright 575 | f_1 2.

f_1
Equivalent dynamic load

$$\frac{F_a}{F_r} \leq e \Rightarrow P = F_r$$

f_2
Equivalent dynamic load

$$\frac{F_a}{F_r} > e \Rightarrow P = 0,4 \cdot F_r + Y \cdot F_a$$

Legend

P	N	Equivalent dynamic bearing load
F_r	N	Radial load
F_a	N	Resulting axial force \blacktriangleright 577 f_1 14. The information in the section "Calculation of internal resulting axial force F_a for single bearings" must be taken into consideration when calculating F_a \blacktriangleright 576
e, Y	-	Factors \blacktriangleright 586 f_1 14.

Bearing pairs in O or X arrangement

For bearing pairs under dynamic load in an O or X arrangement comprising single bearings ▶ 576 | f13 and ▶ 576 | f14.

f13
Equivalent dynamic load

$$\frac{F_a}{F_r} \leq e \Rightarrow P = F_r + 1,12 \cdot Y \cdot F_a$$

f14
Equivalent dynamic load

$$\frac{F_a}{F_r} > e \Rightarrow P = 0,67 \cdot F_r + 1,68 \cdot Y \cdot F_a$$

Legend

P	N	Equivalent dynamic bearing load
F _r	N	Radial load
F _a	N	Resulting axial force ▶ 577 14. The information in the section “Calculation of internal resulting axial force F _a for single bearings” must be taken into consideration when calculating F _a ▶ 576
e, Y	-	Factors ▶ 586 11.

Matched bearing pairs

For matched bearing pairs under dynamic load 313 (320, 322, 329)..-DF-A ▶ 576 | f15 and ▶ 576 | f16.

f15
Equivalent dynamic load

$$\frac{F_a}{F_r} \leq e \Rightarrow P = F_r + Y_1 \cdot F_a$$

f16
Equivalent dynamic load

$$\frac{F_a}{F_r} > e \Rightarrow P = 0,67 \cdot F_r + Y_2 \cdot F_a$$

Legend

P	N	Equivalent dynamic bearing load
F _r	N	Radial load
F _a	N	Resulting axial force. The information in the section “Calculation of internal resulting axial force F _a for single bearings” must be taken into consideration when calculating F _a ▶ 576
e, Y ₁ , Y ₂	-	Factors ▶ 632 11.

Calculation of internal resulting axial force F_a for single bearings and for bearing pairs in an X and O arrangement

Reasons why the internal resulting axial force F_a must be taken into consideration

Single row tapered roller bearings transmit radial forces from one raceway to the other oblique to the bearing axis. In the case of a shaft supported by two single row tapered roller bearings of identical or different size, the radial load on bearing A leads, due to the inclination of the raceways (α₀ ≠ 0°), to an axial load on bearing B. The radial load on bearing B also has the effect of an axial load on bearing A; external forces in bearing systems of this type ▶ 577 | 17 and ▶ 577 | 18. This internal resulting axial force F_a must be taken into consideration in the calculation of the equivalent dynamic bearing load P.

Equations for calculation

Equations for calculation of resulting axial force F_a ▶ 577 | 14.

Preconditions for calculation

Bearing A is subjected to a radial load F_{rA}, bearing B to a radial load F_{rB} ▶ 577 | 17 and ▶ 577 | 18. F_{rA} and F_{rB} act at the central pressure points of the bearings and are always regarded as positive. The bearings are clearance-free, but without preload.



The stated equations for determining the axial load correspond to an approximation carried out under the assumption of a load zone of 180° in bearings under radial load. For a more precise calculation, the use of BEARINX or BEARINX-online is recommended.

14

Equations for calculation of the internal resulting axial force F_a

Parameters ▶ 576 | 6,
▶ 577 | 17 and ▶ 577 | 18

$Y_A = Y_B$ ▶ 586 | 11

Case	Load ratio	External axial force
1	$\frac{F_{rA}}{Y_A} \leq \frac{F_{rB}}{Y_B}$	$K_a \cong 0$
2	$\frac{F_{rA}}{Y_A} > \frac{F_{rB}}{Y_B}$	$K_a > 0,47 \cdot \left(\frac{F_{rA}}{Y_A} - \frac{F_{rB}}{Y_B} \right)$
3		$K_a \leq 0,47 \cdot \left(\frac{F_{rA}}{Y_A} - \frac{F_{rB}}{Y_B} \right)$

continued ▼

14

Equations for calculation of the internal resulting axial force F_a

Parameters ▶ 576 | 6,
▶ 577 | 17 and ▶ 577 | 18

$Y_A = Y_B$ ▶ 586 | 11

Case	Load ratio	Resulting axial force F_a	
		Bearing A	Bearing B
1	$\frac{F_{rA}}{Y_A} \leq \frac{F_{rB}}{Y_B}$	$F_{aA} = K_a + 0,47 \cdot \frac{F_{rB}}{Y_B}$	F_a is not taken into consideration in the calculation
2	$\frac{F_{rA}}{Y_A} > \frac{F_{rB}}{Y_B}$	$F_{aA} = K_a + 0,47 \cdot \frac{F_{rB}}{Y_B}$	F_a is not taken into consideration in the calculation
3		F_a is not taken into consideration in the calculation	$F_{aB} = 0,47 \cdot \frac{F_{rA}}{Y_A} - K_a$

continued ▲

17

Adjusted bearing arrangement with two single row tapered roller bearings in O arrangement, external forces

K_a = external axial force acting on the shaft

F_{rA} = radial load, bearing A

F_{rB} = radial load, bearing B

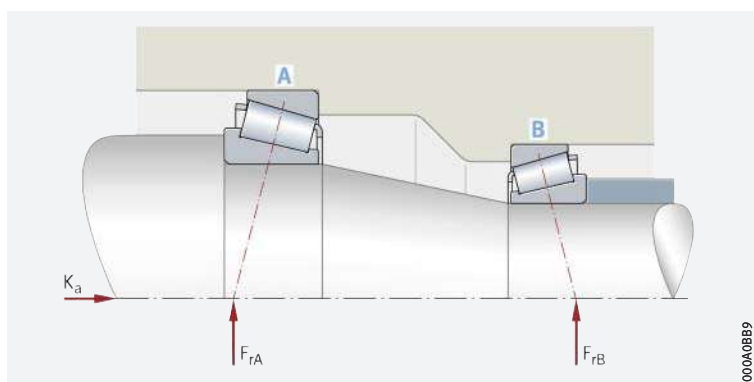

18

Adjusted bearing arrangement with two single row tapered roller bearings in X arrangement, external forces

K_a = external axial force acting on the shaft

F_{rA} = radial load, bearing A

F_{rB} = radial load, bearing B

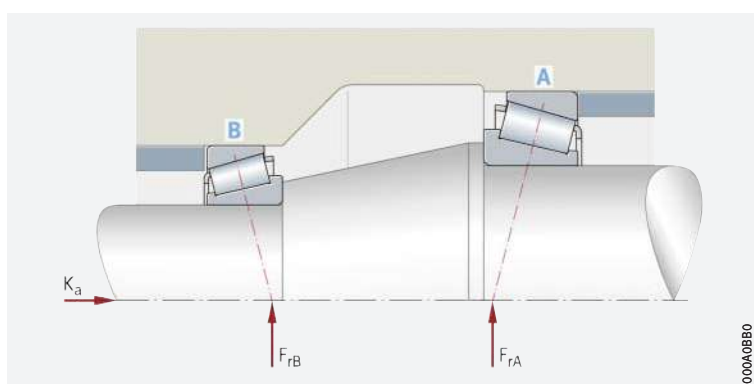

Example of calculation of internal resulting axial force F_a

☞ Bearing arrangement for pinion shaft

Two single row tapered roller bearings are used for the bearing arrangement of a pinion shaft ▶ 578 | 19. The bearing arrangement should be adjusted and in an O arrangement. In order to calculate the basic rating life of bearing A, the equivalent dynamic bearing load P_A must be determined.

19

BEARINX calculation model:
load on bearing A and B

- K_a = external axial force = 6,52 kN
- K_r = external radial force
- K_t = tangential force
- F_{rA} = radial load, bearing A
(resultant of reaction forces F_{yA} and F_{zA})
- F_{rB} = radial load, bearing B
(resultant of reaction forces F_{yB} and F_{zB})
- l_1 = spacing between pinion and contact cone apex of bearing A
- l_2 = spacing between contact cone apexes of bearing A and bearing B

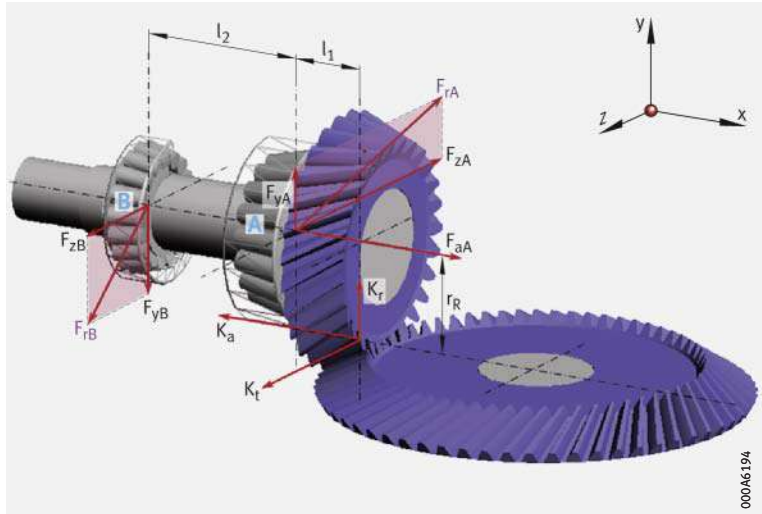

The resulting radial forces F_{rA} and F_{rB} on the bearings must be determined from the external radial force K_r and the tangential force K_t by the solution of the equilibrium of moments and forces on the shaft. Result:

- $F_{rA} = 7,3$ kN
- $F_{rB} = 2,2$ kN.

In a bearing arrangement with two single bearings, the resulting axial force F_a must be taken into consideration

Since this is an adjusted bearing arrangement with two single bearings, the internal resulting axial force F_a in the bearing system must be taken into consideration in the bearing calculation in accordance with **577** **14**. For both tapered roller bearings $Y_A = Y_B = 1,6$. Loads **578** **19**. Tapered roller bearing 32206-XL is envisaged for bearing A.

Step 1

Calculate the load ratio using **578** **7**.

f17
Load ratio



$$\frac{F_{rA}}{Y_A} ; \frac{F_{rB}}{Y_B}$$

$$\frac{F_{rA}}{Y_A} = \frac{7,3 \text{ kN}}{1,6} = 4,56$$

$$\frac{F_{rB}}{Y_B} = \frac{2,2 \text{ kN}}{1,6} = 1,38$$

$$\frac{F_{rA}}{Y_A} > \frac{F_{rB}}{Y_B}$$

Step 2

Compare the result with possible cases **577** **14**. Case 2 or case 3 can be considered **578** **15**.

15

Equations for calculation
of the internal resulting
axial force F_a

Parameters **576** **6**

$$Y_A = Y_B = 1,6$$

Case	Load ratio	External axial force	Resulting axial force F_a	
			Bearing A	Bearing B
2	$\frac{F_{rA}}{Y_A} > \frac{F_{rB}}{Y_B}$	$K_a > 0,47 \cdot \left(\frac{F_{rA}}{Y_A} - \frac{F_{rB}}{Y_B} \right)$	$F_{aA} = K_a + 0,47 \cdot \frac{F_{rB}}{Y_B}$	–
3		$K_a \leq 0,47 \cdot \left(\frac{F_{rA}}{Y_A} - \frac{F_{rB}}{Y_B} \right)$	–	$F_{aB} = 0,47 \cdot \frac{F_{rA}}{Y_A} - K_a$

Step 3

Using ▶ 579 | f18, check whether case 2 applies ▶ 578 | 15.

f18
External axial force
in relation to load ratio

$$K_a > 0,47 \cdot \left(\frac{F_{rA}}{Y_A} - \frac{F_{rB}}{Y_B} \right)$$



$$\begin{aligned} 6,52 \text{ kN} &> 0,47 \left(\frac{7,30 \text{ kN}}{1,6} - \frac{2,20 \text{ kN}}{1,6} \right) \\ &> 0,47 (4,563 \text{ kN} - 1,375 \text{ kN}) \\ 6,52 \text{ kN} &> 1,498 \text{ kN} \end{aligned}$$

If case 2 applies ▶ 578 | 15. This means that bearing A supports the external axial force K_a .

Step 4

Calculating F_a

Using ▶ 579 | f19, calculate the internal resulting axial force F_a for bearing A. The calculations are in accordance with ▶ 578 | 15, case 2.

f19
Internal resulting axial force
for bearing A

$$F_{aA} = K_a + 0,47 \cdot \frac{F_{rB}}{Y_B}$$



$$\begin{aligned} F_{aA} &= 6,52 \text{ kN} + 0,47 \cdot \frac{2,20 \text{ kN}}{1,6} \\ &= 7,17 \text{ kN} \end{aligned}$$

Example of calculation of P

Using value F_a
in the calculation of P

Using ▶ 579 | f10, calculate the ratio between the axial force F_a and radial force F_r of bearing A and compare this with the limit value e in accordance with the product table (in this instance $e = 0,37$).

f10
Load ratio, bearing A

$$\frac{F_{aA}}{F_{rA}}$$



$$\frac{7,17 \text{ kN}}{7,3 \text{ kN}} = 0,98$$

This gives:



$$\frac{F_a}{F_r} > e = 0,37$$

As a result, the axial force F_a of bearing A (F_{aA}) must be taken into consideration within the equivalent bearing load P_A of bearing A ▶ 575 | f12 and thus ▶ 579 | f11 apply.

f11
P for $F_a/F_r > e$

$$P_A = 0,4 \cdot F_{rA} + Y_A \cdot F_{aA}$$



$$\begin{aligned} P_A &= 0,4 \cdot 7,3 \text{ kN} + 1,6 \cdot 7,17 \text{ kN} \\ &= 14,39 \text{ kN} \end{aligned}$$

The equivalent dynamic bearing load P_A of bearing A is then used to calculate the basic rating life of bearing A.



Single bearings and JKOS bearings

Equivalent static bearing load

For single bearings under static load and integral tapered roller bearings
➤ 580 | f12 and ➤ 580 | f13.

f12
Equivalent static load

$$\frac{F_{0a}}{F_{0r}} \leq \frac{1}{2 \cdot Y_0} \Rightarrow P_0 = F_{0r}$$

f13
Equivalent static load

$$\frac{F_{0a}}{F_{0r}} > \frac{1}{2 \cdot Y_0} \Rightarrow P_0 = 0,5 \cdot F_{0r} + Y_0 \cdot F_{0a}$$

Legend

P_0	N	Equivalent static bearing load
F_{0r}, F_{0a}	N	Largest radial or axial load present (maximum load)
Y_0	-	Axial load factor.

For bearing pairs under static load in an O or X arrangement ➤ 580 | f14.

f14
Equivalent static load

$$P_0 = F_{0r} + 2 \cdot Y_0 \cdot F_{0a}$$

Legend

P_0	N	Equivalent static bearing load
F_{0r}, F_{0a}	N	Largest radial or axial load present (maximum load)
Y_0	-	Axial load factor.

For matched bearing pairs under static load 313 (320, 322, 329)..-DF-A..
➤ 580 | f15.

f15
Equivalent static load

$$P_0 = F_{0r} + Y_0 \cdot F_{0a}$$

Legend

P_0	N	Equivalent static bearing load
F_{0r}, F_{0a}	N	Largest radial or axial load present (maximum load)
Y_0	-	Axial load factor.

Static load safety factor

➤ $S_0 = C_0/P_0$

In addition to the basic rating life $L(L_{10h})$, it is also always necessary to check the static load safety factor S_0 ➤ 580 | f16.

f16
Static load safety factor

$$S_0 = \frac{C_0}{P_0}$$

Legend

S_0	-	Static load safety factor
C_0	N	Basic static load rating
P_0	N	Equivalent static bearing load.

1.15 Minimum load

In order to prevent damage due to slippage, a minimum radial load of $P > C_{0r}/60$ is required

In order that no slippage occurs between the contact partners, the tapered roller bearings must be constantly subjected to a sufficiently high load. Based on experience, a minimum radial load of the order of $P > C_{0r}/60$ is thus necessary. In most cases, however, the radial load is already higher than the requisite minimum load due to the weight of the supported parts and the external forces.



If the minimum radial load is lower than indicated above, please consult Schaeffler.

1.16 Design of bearing arrangements

☞ *For secure radial location, tight fits are necessary*

Radial location of bearings

In addition to supporting the rings adequately, the bearings must also be securely located in a radial direction, to prevent creep of the bearing rings on the mating parts under load. This is generally achieved by means of tight fits between the bearing rings and the mating parts. If the rings are not secured adequately or correctly, this can cause severe damage to the bearings and adjacent machine parts. Influencing factors, such as the conditions of rotation, magnitude of the load, internal clearance, temperature conditions, design of the mating parts and the mounting and dismounting options must be taken into consideration in the selection of fits.



If shock type loads occur, tight fits (transition fit or interference fit) are required to prevent the rings from coming loose at any point. Clearance, transition or interference fits ▶ 150 | 6 and ▶ 158 | 7.



The following information provided in Technical principles must be taken into consideration in the design of bearing arrangements:

- conditions of rotation ▶ 145
- tolerance classes for cylindrical shaft seats (radial bearings) ▶ 147 | 2, excluding tapered roller bearings to ANSI/ABMA 19.2:2013 or with special tolerances
- shaft fits ▶ 150 | 6
- tolerance classes for bearing seats in housings (radial bearings) ▶ 148 | 4, excluding tapered roller bearings to ANSI/ABMA 19.2:2013 or with special tolerances
- housing fits ▶ 158 | 7.

Shaft and housing fits for bearings in inch sizes



For bearings with a different tolerance accuracy, such as ANSI/ABMA 19.2:2013 for example, the tolerance class must be shifted in accordance with the fit.

Shaft and housing fits for integral tapered roller bearings

Recommended shaft and housing tolerances for integral tapered roller bearings ▶ 581 | 16.

16
Tolerances for integral tapered roller bearings

Circumferential load	Tolerance class	
	Shaft	Housing
on inner ring	m6 [Ⓔ]	H7 [Ⓔ]
on outer ring	g6 [Ⓔ]	M7 [Ⓔ]

Axial location of bearings

☞ *The bearings must also be securely located in an axial direction*

As a tight fit alone is not normally sufficient to also locate the bearing rings securely on the shaft and in the housing bore in an axial direction, this must usually be achieved by means of an additional axial location or retention method. The axial location of the bearing rings must be matched to the type of bearing arrangement. Shaft and housing shoulders, housing covers, nuts, spacer rings and retaining rings etc., are fundamentally suitable ▶ 584 | 20.



☞ *A minimum of IT6 should be provided for the shaft seat and a minimum of IT7 for the housing seat*

Dimensional, geometrical and running accuracy of the bearing seats

The accuracy of the cylindrical bearing seat on the shaft and in the housing should correspond to the accuracy of the bearing used. For single row tapered roller bearings with the tolerance class Normal or 6X, the shaft seat should correspond to a minimum of standard tolerance grade IT6 and the housing seat to a minimum of IT7; with tolerance class 5, the shaft seat should correspond to a minimum of IT5 and the housing seat to a minimum of IT6. Guide values for the geometrical and positional tolerances of bearing seating surfaces ▶ 582 | 17, tolerances t_1 to t_3 in accordance with ▶ 168 | 11. Numerical values for IT grades ▶ 582 | 18.

17
Guide values for the geometrical and positional tolerances of bearing seating surfaces

Bearing tolerance class		Bearing seating surface	Standard tolerance grades to ISO 286-1 (IT grades)			
to ISO 492	to DIN 620		Diameter tolerance	Roundness tolerance	Parallelism tolerance	Total axial runout tolerance of abutment shoulder
				t_1	t_2	t_3
Normal 6X	PN (P0) P6X	Shaft	IT6 (IT5)	Circumferential load IT4/2	Circumferential load IT4/2	IT4
				Point load IT5/2	Point load IT5/2	
		Housing	IT7 (IT6)	Circumferential load IT5/2	Circumferential load IT5/2	IT5
				Point load IT6/2	Point load IT6/2	
5	P5	Shaft	IT5	Circumferential load IT2/2	Circumferential load IT2/2	IT2
				Point load IT3/2	Point load IT3/2	
		Housing	IT6	Circumferential load IT3/2	Circumferential load IT3/2	IT3
				Point load IT4/2	Point load IT4/2	

18
Numerical values for ISO standard tolerances (IT grades) to ISO 286-1:2010

IT grade	Nominal dimension in mm											
	over 10	18	30	50	80	120	180	250	315	400	500	630
	incl. 18	30	50	80	120	180	250	315	400	500	630	800
Values in μm												
IT2	2	2,5	2,5	3	4	5	7	8	9	10	11	13
IT3	3	4	4	5	6	8	10	12	13	15	16	18
IT4	5	6	7	8	10	12	14	16	18	20	22	25
IT5	8	9	11	13	15	18	20	23	25	27	32	36
IT6	11	13	16	19	22	25	29	32	36	40	44	50
IT7	18	21	25	30	35	40	46	52	57	63	70	80

 *Ra must not be too high*

Roughness of cylindrical bearing seats

The roughness of the bearing seats must be matched to the tolerance class of the bearings. The mean roughness value R_a must not be too high, in order to maintain the interference loss within limits. The shafts must be ground, while the bores must be precision turned. Guide values as a function of the IT grade of bearing seating surfaces [▶ 583](#) |  19.

 **19**
Roughness values
for cylindrical bearing seating
surfaces – guide values

Nominal diameter of the bearing seat d (D) mm		Recommended mean roughness value for ground bearing seats R_{amax} μm			
		Diameter tolerance (IT grade)			
over	incl.	IT7	IT6	IT5	IT4
–	80	1,6	0,8	0,4	0,2
80	500	1,6	1,6	0,8	0,4
500	1 250	3,2 ¹⁾	1,6	1,6	0,8

¹⁾ For the mounting of bearings using the hydraulic method, a value $R_a = 1,6 \mu\text{m}$ must not be exceeded.

Mounting dimensions for the contact surfaces of bearing rings

 *The contact surfaces for the rings must be of sufficient height*

The mounting dimensions of the shaft and housing shoulders, and spacer rings etc., must ensure that the contact surfaces for the bearing rings are of sufficient height. However, they must also reliably prevent rotating parts of the bearing from grazing stationary parts. Proven mounting dimensions for the radii and diameters of the abutment shoulders are defined in accordance with DIN 5418 [▶ 586](#) | . These dimensions are limiting dimensions (maximum or minimum dimensions); the actual values should not be higher or lower than specified.



If single row tapered roller bearings are mounted in a tandem arrangement, it must be ensured that the end faces of the outer rings in contact with each other have sufficient overlap. In case of doubt, please consult Schaeffler.





Cage projection



In the open bearings, the cages project laterally to a certain extent. In order to prevent the cages from grazing the adjacent construction, the lateral minimum distances C_a and C_b in the product tables must be taken into consideration in the design of the adjacent construction [▶ 586](#) | .

Adjustment of bearings

 *Always adjust single bearings against a second bearing*

Due to their internal construction, single row tapered roller bearings cannot be mounted alone, but must always be used together with a second bearing or as a bearing set [▶ 584](#) |  20. In bearing arrangements with two individual single row bearings, these must be adjusted against each other until the requisite preload or desired clearance is achieved [▶ 584](#) |  20. The preload is only achieved once the bearings have been fitted and is dependent on the adjustment against the second bearing.

 *Select the adjustment such that full function and operational reliability of the bearings is ensured*

The correct adjustment of the bearings has a considerable influence on the function and operational reliability of the bearing arrangement. If the clearance is too large, the load carrying capacity of the bearings will not be fully utilised; if the preload is too high, the increased friction losses will give rise to higher operating temperatures, which will, in turn, have a negative effect on the rating life of the bearings.

! In order that the rollers can be positioned correctly, the shaft or housing must be rotated several times in both directions when adjusting the bearings.

20
Adjusted bearing arrangement with two single row tapered roller bearings

H = support spacing

- ① Tapered roller bearings mounted in an O arrangement and adjusted against each other
- ② Fixing nut

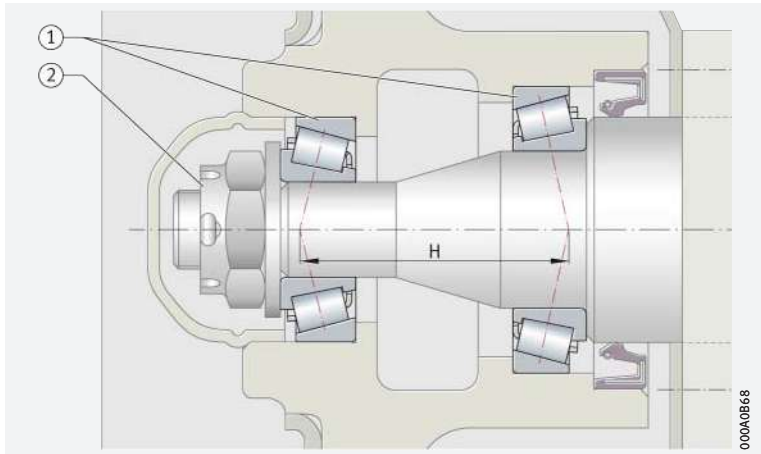

Matched bearings

Adjustment not required for matched bearing sets

Matched tapered roller bearings do not need to be adjusted ▶ 558 | 1.1. The desired operating clearance or required preload is already set at the manufacturing plant.

1.17

Mounting and dismounting



The mounting and dismounting options for tapered roller bearings, by thermal, hydraulic or mechanical methods, must be taken into consideration in the design of the bearing position.

Ensure that the bearings are not damaged during mounting

Integral tapered roller bearings are not separable. In the mounting of such bearings, the mounting forces must always be applied to the bearing ring with a tight fit.

Rolling bearings must be handled with great care

Schaeffler Mounting Handbook

Rolling bearings are well-proven precision machine elements for the design of economical and reliable bearing arrangements, which offer high operational security. In order that these products can function correctly and achieve the envisaged operating life without detrimental effect, they must be handled with care.



The Schaeffler Mounting Handbook MH 1 gives comprehensive information about the correct storage, mounting, dismounting and maintenance of rotary rolling bearings ▶ <https://www.schaeffler.de/std/1D53>. It also provides information which should be observed by the designer, in relation to the mounting, dismounting and maintenance of bearings, in the original design of the bearing position. This book is available from Schaeffler on request.

1.18 Legal notice regarding data freshness

The further development of products may also result in technical changes to catalogue products

Of central interest to Schaeffler is the further development and optimisation of its products and the satisfaction of its customers. In order that you, as the customer, can keep yourself optimally informed about the progress that is being made here and with regard to the current technical status of the products, we publish any product changes which differ from the printed version in our electronic product catalogue.



We therefore reserve the right to make changes to the data and illustrations in this catalogue. This catalogue reflects the status at the time of printing. More recent publications released by us (as printed or digital media) will automatically precede this catalogue if they involve the same subject. Therefore, please always use our electronic product catalogue to check whether more up-to-date information or modification notices exist for your desired product.

Link to electronic product catalogue



The following link will take you to the Schaeffler electronic product catalogue: ► <https://medias.schaeffler.com>.

1.19 Further information



In addition to the data in this chapter, the following chapters in Technical principles must also be observed in the design of bearing arrangements:

- Determining the bearing size ► 34
- Rigidity ► 54
- Friction and increases in temperature ► 56
- Speeds ► 64
- Bearing data ► 97
- Lubrication ► 70
- Sealing ► 182
- Design of bearing arrangements ► 139
- Mounting and dismounting ► 191.



Tapered roller bearings

Single row to DIN/ISO

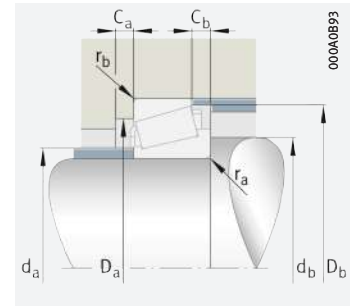
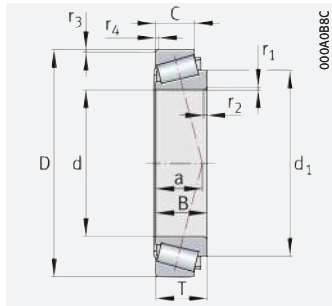

Mounting dimensions

d = 15 – 25 mm

Main dimensions					Basic load ratings		Fatigue limit load C_{ur} N	Limiting speed n_G min^{-1}	Speed rating $n_{\theta r}$ min^{-1}	Mass m \approx kg	Designation	Interchange designation to ISO 10317 and ISO 355
d	D	B	C	T	dyn. C_r N	stat. C_{0r} N						
15	35	11	10	11,75	17 700	14 400	1 740	26 000	13 400	0,055	30202-XL	–
	42	13	11	14,25	27 500	20 800	2 800	21 700	12 000	0,095	30302-XL	T2FB015
17	40	12	11	13,25	22 900	19 000	2 490	22 200	11 800	0,079	30203-XL	T2DB017
	40	16	14	17,25	34 500	30 000	4 300	21 400	10 700	0,107	32203-XL	T2DD017
	47	14	12	15,25	33 000	25 000	3 400	19 300	10 800	0,13	30303-XL	T2FB017
	47	19	16	20,25	36 500	36 000	3 750	17 200	10 300	0,181	32303-A	T2FD017
20	37	12	9	12	15 700	18 400	1 960	21 100	11 700	0,053	32904	T2BD020
	42	15	12	15	28 500	29 000	3 950	19 900	10 700	0,111	32004-X-XL	T3CC020
	45	14	10	14	22 200	21 100	2 240	17 500	10 700	0,103	T4DB020	–
	47	14	12	15,25	32 000	27 500	3 800	18 500	10 100	0,121	30204-XL	T2DB020
	47	18	15	19,25	39 000	37 000	5 600	17 600	9 500	0,17	32204-B-XL	T5DD020
	47	18	15	19,25	40 500	36 500	5 400	18 400	9 700	0,165	32204-XL	T2DD020
	50	22	18,5	22	46 000	49 000	5 800	15 400	9 400	0,23	T2ED020	–
	52	15	13	16,25	34 000	32 500	3 600	15 600	9 700	0,187	30304-A	T2FB020
	52	15	11	16,25	30 500	29 500	3 350	14 900	8 400	0,174	31304	–
	52	21	18	22,25	46 000	47 500	5 600	15 200	9 400	0,241	32304-A	T2FD020
22	40	12	9	12	16 000	18 100	1 910	19 300	10 700	0,065	329/22	T2BC022
	44	15	11,5	15	24 800	30 500	3 200	17 000	10 000	0,11	320/22-X	T3CC022
	47	14	10	14	23 300	22 800	2 430	16 600	10 000	0,109	T4CB022	–
	52	22	18,5	22	47 500	51 000	6 000	14 600	8 800	0,239	T2ED022	–
	56	16	14	17,25	38 000	36 000	4 050	14 600	9 400	0,21	303/22	–
25	42	12	9	12	14 900	18 800	1 910	18 000	9 900	0,067	32905	T2BD025
	47	17	14	17	33 000	41 500	4 650	15 700	9 400	0,133	33005	T2CE025
	47	15	11,5	15	31 500	34 000	4 700	17 200	9 000	0,117	32005-X-XL	T4CC025
	50	14	10	14	24 200	24 600	2 650	15 300	9 200	0,121	T4CB025	–
	52	22	18	22	48 500	58 000	6 900	14 200	8 300	0,222	33205	T2DE025
	52	15	13	16,25	38 500	35 500	5 000	16 400	9 100	0,154	30205-XL	T3CC025
	52	18	15	19,25	44 500	46 000	7 000	15 500	8 100	0,195	32205-B-XL	T5CD025
	52	18	16	19,25	47 500	45 000	6 700	15 900	8 000	0,186	32205-XL	T2CD025
	58	26	21	26	61 000	69 000	8 500	12 900	8 200	0,349	T2EE025	–
	62	17	15	18,25	47 000	45 500	5 100	12 800	8 000	0,264	30305-A	T2FB025
	62	17	13	18,25	37 000	38 500	4 400	12 000	7 100	0,297	31305-A	T7FB025
	62	24	20	25,25	62 000	66 000	7 800	12 500	7 800	0,378	32305-A	T2FD025
	62	24	20	25,25	57 000	66 000	8 000	12 200	7 900	0,405	32305-B	–

medias ► <https://www.schaeffler.de/std/1EFB>



Dimensions					Mounting dimensions								Calculation factors			
d	r ₁ , r ₂	r ₃ , r ₄	a	d ₁	d _a	d _b	D _a	D _a	D _b	C _a	C _b	r _a	r _b	e	Y	Y ₀
	min.	min.	≈	≈	max.	min.	min.	max.	min.	min.	min.	max.	max.			
15	0,6	0,6	9	25,8	20	19	29	29	32	2	1,5	0,6	0,6	0,35	1,73	0,95
	1	1	10	28,7	22	21	36	36	38	2	3	1	1	0,29	2,11	1,16
17	1	1	10	29,5	23	23	34	34	37	2	2	1	1	0,35	1,74	0,96
	1	1	11	29,3	22	23	34	34	37	3	3	1	1	0,31	1,92	1,06
	1	1	11	32	25	23	40	41	42	2	3	1	1	0,29	2,11	1,16
	1	1	12	31,5	24	23	39	41	43	3	4	1	1	0,29	2,11	1,16
20	0,3	0,3	8	29,5	24	24	32	34	34	2	3	0,3	0,3	0,32	1,88	1,04
	0,6	0,6	10	33,1	25	25	36	37	39	3	3	0,6	0,6	0,37	1,6	0,88
	1	1	11	32,9	26	27	38	40	42	3	4	1	1	0,45	1,34	0,73
	1	1	12	34,7	27	26	40	41	43	2	3	1	1	0,35	1,74	0,96
	1	1	15	36,2	26	27	37	41	44	2	4	1	1	0,52	1,16	0,64
	1	1	13	33,9	26	26	39	41	43	3	4	1	1	0,33	1,81	1
	2	1,5	14	35	26	28	41	43	47	4	3	2	1,5	0,33	1,8	0,99
	1,5	1,5	12	36,1	28	27	44	45	47	2	3	1,5	1,5	0,3	2	1,1
	1,5	1,5	16	37,3	27	27	40	45	48	3	5	1,5	1,5	0,73	0,82	0,45
22	0,3	0,3	9	31,5	26	26	35	37	37	2	3	0,3	0,3	0,32	1,88	1,04
	0,6	0,6	11	35,3	27	27	38	39	41	3	3,5	0,6	0,6	0,4	1,51	0,83
	1	1	12	34,9	28	29	40	42	44	3	4	1	1	0,47	1,27	0,7
	2	1,5	14	36,9	28	30	43	45	49	4	3,5	2	1,5	0,33	1,84	1,01
	1,5	1,5	12	37,3	30	29	47	49	50	2	3	1,5	1,5	0,3	2,01	1,1
25	0,3	0,3	9	34,2	29	30	37	38	39	2	3	0,3	0,3	0,32	1,88	1,04
	0,6	0,6	11	37,3	30	30	41	42	44	3	3	0,6	0,6	0,29	2,07	1,14
	0,6	0,6	12	38,5	30	30	40	42	44	3	3,5	0,6	0,6	0,43	1,39	0,77
	1	1	13	38	30	32	43	45	47	3	4	1	1	0,51	1,18	0,65
	1	1	14	39,6	30	31	43	46	49	4	4	1	1	0,35	1,71	0,94
	1	1	13	38,5	31	31	44	46	48	2	3	1	1	0,37	1,6	0,88
	1	1	16	41,3	30	31	41	46	49	2	4	1	1	0,58	1,03	0,57
	1	1	14	39,5	31	31	44	46	48	3	3	1	1	0,36	1,67	0,92
	2	1,5	16	42	32	34	48	51	54	4	5	2	1,5	0,33	1,8	0,99
	1,5	1,5	13	42,3	34	32	54	55	57	2	3	1,5	1,5	0,3	2	1,1
	1,5	1,5	21	46,3	34	32	47	55	59	3	5	1,5	1,5	0,83	0,73	0,4
	1,5	1,5	16	42,3	33	32	53	55	57	3	5	1,5	1,5	0,3	2	1,1
1,5	1,5	20	45,7	31	36	46	55	58	3	5	1,5	1,5	0,55	1,1	0,6	





Tapered roller bearings

Single row to DIN/ISO

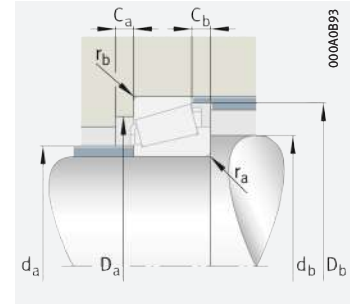
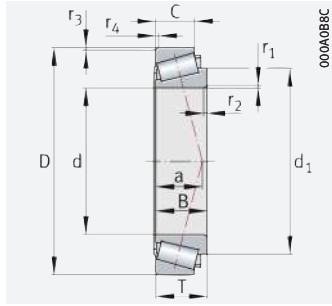

Mounting dimensions

d = 28 – 32 mm

Main dimensions					Basic load ratings		Fatigue limit load	Limiting speed	Speed rating	Mass	Designation	Interchange designation to ISO 10317 and ISO 355
d	D	B	C	T	dyn. C_r	stat. C_{0r}	C_{ur}	n_G	$n_{\theta r}$	m	▶ 573 1.12 ▶ 574 1.13 X-life ▶ 559	
					N	N	N	min^{-1}	min^{-1}	≈ kg		
28	45	12	9	12	15 800	20 900	2 130	16 700	8 900	0,073	329/28	T2BD028
	52	16	12	16	34 000	40 500	4 550	14 200	8 400	0,164	320/28-X	T4CC028
	55	14,5	11	15	30 000	31 000	3 400	13 900	8 400	0,151	T4CB028	–
	58	19	16	20,25	43 500	52 000	6 100	12 800	7 500	0,257	322/28-B	T5DD028
	58	24	19	24	57 000	66 000	8 000	12 700	7 700	0,306	332/28	–
	65	27	22	27	71 000	78 000	9 400	11 600	7 500	0,451	T2ED028	–
	68	18	16	19,75	53 000	51 000	5 800	11 700	7 600	0,342	303/28	–
	30	47	12	9	12	16 300	22 000	2 260	15 900	8 400	0,077	32906
55		17	13	17	46 000	47 000	6 500	14 600	7 900	0,174	32006-X-XL	T4CC030
55		20	16	20	53 000	57 000	8 800	14 500	8 300	0,212	33006-XL	T2CE030
60		16,5	12,5	17	38 000	38 500	4 500	12 600	8 000	0,207	T4CB030	–
62		16	14	17,25	52 000	48 500	7 200	13 700	7 400	0,238	320206-XL	T3DB030
62		20	17	21,25	62 000	65 000	9 700	12 900	6 700	0,28	32206-B-XL	T5DC030
62		20	17	21,25	63 000	62 000	9 700	13 300	6 800	0,28	32206-XL	T3DC030
62		25	19,5	25	77 000	78 000	12 400	13 000	7 000	0,365	33206-XL	T2DE030
68		29	24	29	80 000	93 000	11 500	10 900	7 100	0,534	T2EE030	–
72		19	16	20,75	77 000	61 000	8 400	12 100	7 100	0,445	30306-XL	T2FB030
72		19	14	20,75	45 000	46 500	5 300	10 300	6 400	0,441	31306-A	T7FB030
72		27	23	28,75	80 000	89 000	10 800	10 700	7 000	0,57	32306-A	T2FD030
32	72	27	23	28,75	73 000	87 000	10 600	10 400	7 100	0,602	32306-B	T5FD030
	52	15	10	14	24 200	30 500	3 000	14 300	7 900	0,114	329/32	T2BD032
	58	17	13	17	39 000	48 500	5 600	12 600	7 500	0,197	320/32-X	T4CC032
	65	17	15	18,25	47 500	52 000	6 100	11 800	7 300	0,279	302/32	T3DB032
	65	26	20,5	26	71 000	85 000	10 500	11 200	6 800	0,41	332/32	T2DE032
	65	17,5	13,5	18	43 500	45 000	5 300	11 700	7 500	0,262	T4DB032	–
	72	29	24	29	87 000	100 000	12 200	10 400	6 700	0,594	T2ED032	–
	75	20	17,5	21,75	67 000	68 000	7 900	10 400	6 800	0,464	303/32	–

medias ▶ <https://www.schaeffler.de/std/1EFC>



Dimensions					Mounting dimensions								Calculation factors			
d	r ₁ , r ₂	r ₃ , r ₄	a	d ₁	d _a	d _b	D _a	D _a	D _b	C _a	C _b	r _a	r _b	e	Y	Y ₀
	min.	min.	≈	≈	max.	min.	min.	max.	min.	min.	min.	max.	max.			
28	0,3	0,3	9	37,3	32	32	41	41	42	2	3	0,3	0,3	0,32	1,88	1,04
	1	1	13	41	33	34	45	46	49	3	4	1	1	0,43	1,39	0,77
	1	1	13	41,4	34	35	48	49	52	3	4	1	1	0,47	1,27	0,7
	1	1	17	44,8	33	34	46	52	55	3	4	1	1	0,56	1,07	0,59
	1	1	16	43,1	33	34	49	52	55	4	5	1	1	0,34	1,77	0,97
	2	2	18	45,6	35	37	54	57	61	5	5	2	2	0,34	1,77	0,97
	1,5	1,5	14	46,5	38	35	59	61	62	3	3,5	1,5	1,5	0,3	2	1,1
30	0,3	0,3	9	39,2	34	34	43	43	44	2	3	0,3	0,3	0,32	1,88	1,04
	1	1	14	43,9	35	36	48	49	52	3	4	1	1	0,43	1,39	0,77
	1	1	13	43,8	35	36	48	49	52	3	4	1	1	0,29	2,06	1,13
	1	1	15	44,6	36	37	52	54	57	3	4,5	1	1	0,47	1,27	0,7
	1	1	14	46,2	37	36	53	56	57	2	3	1	1	0,37	1,6	0,88
	1	1	18	48,5	36	36	50	56	60	3	4	1	1	0,56	1,07	0,59
	1	1	16	46,8	37	36	52	56	59	3	4	1	1	0,37	1,6	0,88
	1	1	16	46,9	36	36	53	56	59	5	5,5	1	1	0,34	1,76	0,97
	2	2	19	48,8	37	40	56	60	64	5	5	2	2	0,33	1,81	1
	1,5	1,5	15	50,1	40	37	62	65	66	3	4,5	1,5	1,5	0,32	1,9	1,05
	1,5	1,5	24	54	40	37	55	65	68	3	6,5	1,5	1,5	0,83	0,73	0,4
	1,5	1,5	18	49,3	39	37	59	65	66	4	5,5	1,5	1,5	0,32	1,9	1,05
	1,5	1,5	23	52,7	38	37	59	65	67	4	5,5	1,5	1,5	0,55	1,1	0,6
32	0,6	0,6	10	42,4	36	37	47	48	49	3	3	0,6	0,6	0,32	1,88	1,04
	1	1	14	46,5	38	38	50	52	55	3	4	1	1	0,45	1,32	0,73
	1	1	14	47,7	39	38	56	59	60	3	3	1	1	0,37	1,6	0,88
	1	1	17	48,6	38	38	55	59	62	4	5,5	1	1	0,35	1,73	0,95
	1	1	16	48	39	40	56	59	61	3	4,5	1	1	0,47	1,27	0,7
	2	2	19	51,1	40	42	60	64	67	5	5	2	2	0,34	1,78	0,98
	2	1,5	16	51,8	42	39	65	68	69	3	4	2	1,5	0,32	1,9	1,05



Tapered roller bearings

Single row to DIN/ISO

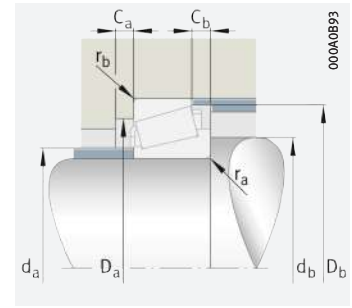
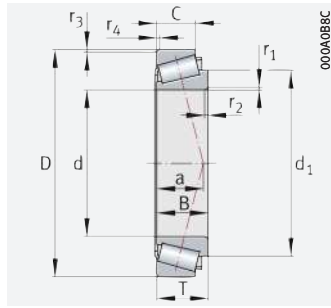

Mounting dimensions

d = 35 – 42 mm

Main dimensions					Basic load ratings		Fatigue limit load	Limiting speed	Speed rating	Mass	Designation	Interchange designation to ISO 10317 and ISO 355
d	D	B	C	T	dyn. C_r	stat. C_{0r}	C_{ur}	n_G	$n_{\theta r}$	m	▶ 573 1.12 ▶ 574 1.13 X-life ▶ 559	
					N	N	N	min^{-1}	min^{-1}	≈ kg		
35	55	14	11,5	14	27 500	38 000	3 850	13 200	7 000	0,127	32907	T2BD035
	62	21	17	21	53 000	70 000	8 500	11 500	7 200	0,273	33007	T2CE035
	62	18	14	18	54 000	57 000	8 900	12 800	7 000	0,225	32007-X-XL	T4CC035
	70	18	14	19	51 000	55 000	6 400	10 800	6 900	0,317	T4DB035	–
	72	17	15	18,25	64 000	59 000	8 900	11 700	6 400	0,336	30207-XL	T3DB035
	72	23	19	24,25	75 000	80 000	12 500	11 100	6 200	0,464	32207-B-XL	T5DC035
	72	23	19	24,25	84 000	85 000	13 400	11 400	6 000	0,449	32207-XL	T3DC035
	72	28	22	28	103 000	105 000	16 800	11 100	6 200	0,555	33207-XL	T2DE035
	78	32,5	27	33	106 000	120 000	14 700	9 400	6 400	0,777	T2EE035	–
	80	21	18	22,75	73 000	75 000	8 600	9 700	6 500	0,525	30307-A	T2FB035
	80	21	15	22,75	60 000	64 000	7 500	9 100	5 700	0,514	31307-A	T7FB035
80	31	25	32,75	100 000	113 000	13 600	9 400	6 500	0,758	32307-A	T2FE035	
80	31	25	32,75	95 000	116 000	14 400	9 100	6 400	0,806	32307-B	T5FE035	
38	65	18	14	18	49 000	64 000	7 500	11 100	6 400	0,252	320/38-X	–
40	62	15	12	15	32 500	46 000	5 000	11 700	6 200	0,186	32908	T2BC040
	68	22	18	22	62 000	87 000	10 600	10 400	6 300	0,34	33008	T2BE040
	68	19	14,5	19	63 000	71 000	10 100	11 600	6 200	0,28	32008-X-XL	T3CD040
	75	26	20,5	26	93 000	104 000	16 800	10 400	5 500	0,517	33108-XL	T2CE040
	75	18	14	19	53 000	59 000	6 900	9 900	6 300	0,345	T4CB040	–
	80	32	25	32	105 000	134 000	16 600	9 000	5 700	0,741	33208	T2DE040
	80	18	16	19,75	73 000	67 000	10 100	10 500	5 900	0,432	30208-XL	T3DB040
	80	23	19	24,75	87 000	88 000	13 900	10 000	5 500	0,57	32208-B-XL	T5DC040
	80	23	19	24,75	94 000	94 000	14 700	10 200	5 300	0,6	32208-XL	T3DC040
	85	32,5	28	33	114 000	139 000	17 000	8 600	5 700	0,9	T2EE040	–
	90	23	20	25,25	91 000	102 000	11 900	8 500	5 700	0,812	30308-A	T2FB040
90	23	17	25,25	89 000	83 000	12 100	8 700	5 100	0,723	31308-XL	T7FB040	
90	33	27	35,25	120 000	149 000	18 200	8 000	5 600	1,08	32308-B	–	
90	33	27	35,25	143 000	148 000	23 400	9 200	5 700	1,09	32308-XL	T2FD040	
42	72	20	15,5	20	59 000	82 000	9 800	9 900	5 700	0,345	320/42-X	–

medias ▶ <https://www.schaeffler.de/std/1EFD>



Dimensions					Mounting dimensions								Calculation factors			
d	r ₁ , r ₂	r ₃ , r ₄	a	d ₁	d _a	d _b	D _a	D _a	D _b	C _a	C _b	r _a	r _b	e	Y	Y ₀
	min.	min.	≈	≈	max.	min.	min.	max.	min.	min.	min.	max.	max.			
35	0,6	0,6	11	45,7	40	40	50	50	52	3	3	0,6	0,6	0,29	2,06	1,13
	1	1	14	49,2	41	41	55	56	59	4	4	1	1	0,31	1,97	1,08
	1	1	15	50,1	40	41	54	56	59	4	4	1	1	0,45	1,32	0,73
	1	1	16	51,8	43	43	61	64	66	4	5	1	1	0,45	1,32	0,73
	1,5	1,5	15	53,4	44	42	62	65	67	3	3	1,5	1,5	0,37	1,6	0,88
	1,5	1,5	22	56	42	42	56	65	68	3	5	1,5	1,5	0,58	1,03	0,57
	1,5	1,5	18	53,9	43	42	61	65	67	3	5,5	1,5	1,5	0,37	1,6	0,88
	1,5	1,5	18	53,9	42	42	61	65	68	5	6	1,5	1,5	0,35	1,7	0,93
	2,5	2	21	55,3	43	45	65	70	74	6	6	2,5	2	0,32	1,85	1,02
	2	1,5	16	55,2	45	44	70	71	74	3	4,5	2	1,5	0,32	1,9	1,05
	2	1,5	26	59,9	44	44	62	71	76	4	7,5	2	1,5	0,83	0,73	0,4
	2	1,5	20	55,2	44	44	66	71	74	4	7,5	2	1,5	0,32	1,9	1,05
	2	1,5	25	59,8	42	44	61	71	76	4	7,5	2	1,5	0,55	1,1	0,6
38	1	1	14	52	43	44	58	59	62	4	4	1	1	0,37	1,6	0,88
40	0,6	0,6	12	51,6	45	45	57	57	59	3	3	0,6	0,6	0,29	2,07	1,14
	1	1	15	54,6	46	46	61	62	65	4	4	1	1	0,28	2,12	1,17
	1	1	15	55,2	46	46	60	62	65	4	4,5	1	1	0,38	1,58	0,87
	1,5	1,5	18	59,2	47	47	65	68	71	4	5,5	1,5	1,5	0,36	1,69	0,93
	1	1	18	57,5	47	48	65	69	71	4	5	1	1	0,49	1,22	0,67
	1,5	1,5	21	60,1	47	47	67	73	76	5	7	1,5	1,5	0,36	1,68	0,92
	1,5	1,5	17	59	49	47	69	73	74	3	3,5	1,5	1,5	0,37	1,6	0,88
	1,5	1,5	22	61,1	48	47	65	73	76	4	5,5	1,5	1,5	0,55	1,1	0,6
	1,5	1,5	19	60	48	47	68	73	75	3	5,5	1,5	1,5	0,37	1,6	0,88
	2,5	2	22	61,9	48	51	70	75	80	6	5	2,5	2	0,34	1,74	0,96
	2	1,5	19	63,3	52	49	77	81	82	3	5	2	1,5	0,35	1,74	0,96
	2	1,5	30	67,7	51	49	71	81	86	4	8	2	1,5	0,83	0,73	0,4
	2	1,5	28	67	50	49	69	81	85	4	8	2	1,5	0,55	1,1	0,6
2	1,5	23	64,2	50	49	73	81	82	4	8	2	1,5	0,35	1,74	0,96	
42	1	1	16	58,3	48	48	64	66	69	4	4,5	1	1	0,37	1,6	0,88



Tapered roller bearings

Single row to DIN/ISO

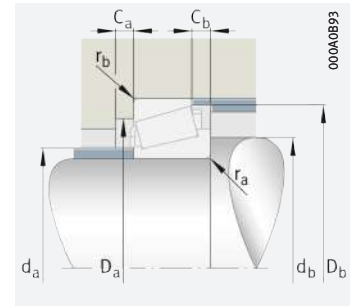
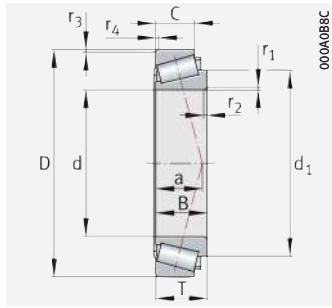

Mounting dimensions

d = 45 – 50 mm

Main dimensions					Basic load ratings		Fatigue limit load	Limiting speed	Speed rating	Mass	Designation	Interchange designation to ISO 10317 and ISO 355
d	D	B	C	T	dyn. Cr	stat. Cor	C _{ur}	n _G	n _{thr}	m	▶ 573 1.12 ▶ 574 1.13 X-life ▶ 559	
					N	N	N	min ⁻¹	min ⁻¹	≈ kg		
45	68	15	12	15	34 500	52 000	5 700	10 600	5 500	0,196		32909
	75	24	19	24	71 000	103 000	12 700	9 400	5 900	0,432	33009	T2CE045
	75	20	15,5	20	72 000	86 000	13 300	10 300	5 400	0,355	32009-X-XL	T3CC045
	80	26	20,5	26	84 000	115 000	14 400	8 800	4 950	0,542	33109	T3CE045
	85	32	25	32	107 000	146 000	18 300	8 200	5 200	0,8	33209	T3DE045
	85	19	16	20,75	84 000	83 000	12 600	9 600	5 400	0,488	30209-XL	T3DB045
	85	23	19	24,75	93 000	99 000	15 500	9 200	4 950	0,62	32209-B-XL	T5DC045
	85	23	19	24,75	97 000	100 000	15 700	9 400	4 850	0,592	32209-XL	T3DC045
	85	20	15,5	21	69 000	77 000	9 200	8 700	5 600	0,497	T4DB045	–
	90	31	26	32	105 000	141 000	17 800	7 900	5 200	0,967	T5ED045	–
	95	35	30	36	143 000	175 000	21 600	7 700	5 100	1,22	T2ED045	–
	95	26,5	20	29	105 000	109 000	16 600	8 100	6 100	0,93	T7FC045-XL	–
	100	25	22	27,25	111 000	125 000	14 800	7 600	5 100	0,997	30309-A	T2FB045
	100	25	18	27,25	114 000	108 000	16 000	7 800	4 650	0,97	31309-XL	T7FB045
100	36	30	38,25	154 000	193 000	23 900	7 300	4 900	1,42	32309-A	T2FD045	
100	36	30	38,25	144 000	188 000	23 200	7 200	5 100	1,46	32309-BA	T5FD045	
50	72	15	12	15	35 500	55 000	6 100	9 900	5 100	0,2	32910	T2BC050
	80	20	15,5	20	75 000	94 000	14 500	9 600	4 950	0,39	32010-X-XL	T3CC050
	80	24	19	24	89 000	114 000	18 200	9 600	5 300	0,454	33010-XL	T2CE050
	85	26	20	26	86 000	122 000	15 200	8 200	4 600	0,59	33110	T3CE050
	90	20	17	21,75	94 000	97 000	14 800	9 000	5 000	0,564	30210-XL	T3DB050
	90	23	19	24,75	98 000	102 000	16 000	8 600	4 600	0,66	32210-B-XL	T5DC050
	90	23	19	24,75	104 000	110 000	17 300	8 800	4 500	0,702	32210-XL	T3DC050
	90	32	24,5	32	136 000	163 000	26 500	8 400	4 700	0,87	33210-XL	T3DE050
	90	20	15,5	21	71 000	82 000	9 800	8 100	5 200	0,534	T4DB050	–
	100	35	30	36	150 000	188 000	23 400	7 200	4 750	1,28	T2ED050	–
	100	34,5	29	36	131 000	183 000	23 100	7 000	4 750	1,35	T5ED050	–
	105	29	22	32	127 000	135 000	20 700	7 200	5 600	1,23	T7FC050-XL	–
	110	27	23	29,25	130 000	148 000	17 700	6 800	4 700	1,25	30310-A	T2FB050
	110	27	19	29,25	131 000	125 000	18 500	7 100	4 300	1,25	31310-XL	T7FB050
	110	40	33	42,25	187 000	237 000	29 500	6 600	4 550	1,9	32310-A	T2FD050
	110	40	33	42,25	165 000	223 000	28 000	6 500	4 800	1,95	32310-B	T5FD050

medias ▶ <https://www.schaeffler.de/std/1EFE>



Dimensions					Mounting dimensions										Calculation factors		
d	r ₁ , r ₂	r ₃ , r ₄	a	d ₁	d _a	d _b	D _a	D _a	D _b	C _a	C _b	r _a	r _b	e	Y	Y ₀	
	min.	min.	≈	≈	max.	min.	min.	max.	min.	min.	min.	max.	max.				
45	0,6	0,6	12	57,8	51	50	62	63	64	3	3	0,6	0,6	0,32	1,88	1,04	
	1	1	16	61,8	51	51	67	69	71	4	5	1	1	0,29	2,04	1,12	
	1	1	17	62,2	51	51	67	69	72	4	4,5	1	1	0,39	1,53	0,84	
	1,5	1,5	19	63,8	52	52	69	73	77	4	5,5	1,5	1,5	0,38	1,57	0,86	
	1,5	1,5	22	66,2	52	52	72	78	81	5	7	1,5	1,5	0,39	1,56	0,86	
	1,5	1,5	18	64,8	54	52	74	78	80	3	4,5	1,5	1,5	0,4	1,48	0,81	
	1,5	1,5	24	66,8	53	52	70	78	82	4	5,5	1,5	1,5	0,59	1,01	0,56	
	1,5	1,5	20	65,6	53	52	73	78	80	3	5,5	1,5	1,5	0,4	1,48	0,81	
	2	2	19	63,7	53	54	74	77	80	5	5,5	2	2	0,46	1,31	0,72	
	4	2	27	69,7	52	57	70	82	86	5	6	4	2	0,55	1,1	0,6	
	2,5	2,5	24	68,8	54	56	80	83	89	6	6	2,5	2,5	0,32	1,86	1,02	
	2,5	2,5	33	73,5	53	59	71	83	91	5	9	2,5	2,5	0,87	0,69	0,38	
	2	1,5	21	70,7	59	54	86	91	92	3	5	2	1,5	0,35	1,74	0,96	
	2	1,5	32	74,7	56	54	79	91	95	4	9	2	1,5	0,83	0,73	0,4	
	2	1,5	26	71,1	56	54	82	91	93	4	8	2	1,5	0,35	1,74	0,96	
2	1,5	30	74,2	55	54	76	91	94	5	8	2	1,5	0,55	1,1	0,6		
50	0,6	0,6	14	61,6	55	55	66	67	69	3	3	0,6	0,6	0,34	1,76	0,97	
	1	1	18	67,3	56	56	72	74	77	4	4,5	1	1	0,42	1,42	0,78	
	1	1	18	66,5	56	56	72	74	76	4	5	1	1	0,32	1,9	1,04	
	1,5	1,5	21	69,1	56	57	74	78	82	4	6	1,5	1,5	0,41	1,46	0,8	
	1,5	1,5	20	69,7	58	57	79	83	85	3	4,5	1,5	1,5	0,42	1,43	0,79	
	1,5	1,5	25	71,2	57	57	76	83	87	4	6,5	1,5	1,5	0,59	1,02	0,56	
	1,5	1,5	21	70,1	58	57	78	83	85	3	5,5	1,5	1,5	0,42	1,43	0,79	
	1,5	1,5	24	72,5	57	57	77	83	87	5	7,5	1,5	1,5	0,41	1,45	0,8	
	2	2	21	69	58	59	79	82	85	4	5,5	2	2	0,49	1,23	0,67	
	2,5	2,5	25	73,5	59	61	84	90	94	6	6	2,5	2,5	0,34	1,75	0,96	
	4	2	30	77,7	59	64	78	91	95	5	7	4	2	0,53	1,13	0,62	
	3	3	36	81,1	59	65	78	91	100	5	10	3	3	0,87	0,69	0,38	
	2,5	2	23	77,6	65	60	95	100	102	4	6	2,5	2	0,35	1,74	0,96	
	2,5	2	35	81,7	62	60	87	100	104	4	10	2,5	2	0,83	0,73	0,4	
	2,5	2	29	79,1	62	60	90	100	102	5	9	2,5	2	0,35	1,74	0,96	
2,5	2	33	82,3	60	60	83	100	103	5	9	2,5	2	0,55	1,1	0,6		



Tapered roller bearings

Single row to DIN/ISO

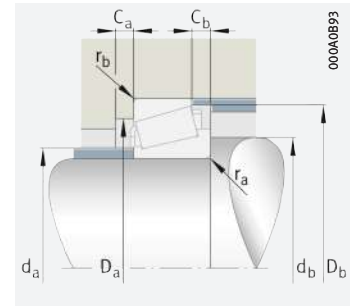
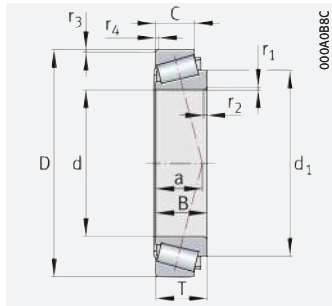

Mounting dimensions

d = 55 – 60 mm

Main dimensions					Basic load ratings		Fatigue limit load	Limiting speed	Speed rating	Mass	Designation	Interchange designation to ISO 10317 and ISO 355
d	D	B	C	T	dyn. C_r	stat. C_{0r}	C_{ur}	n_G	$n_{\theta r}$	m	▶ 573 1.12 ▶ 574 1.13 X-life ▶ 559	
					N	N	N	min ⁻¹	min ⁻¹	≈ kg		
55	80	17	14	17	46 500	78 000	9 000	8 900	4 650	0,304		32911
	90	27	21	27	94 000	142 000	18 000	7 700	4 900	0,671	33011	T2CE055
	90	23	17,5	23	96 000	118 000	18 800	8 500	4 600	0,57	32011-X-XL	T3CC055
	95	30	23	30	113 000	163 000	20 400	7 300	4 250	0,873	33111	T3CE055
	95	20	15,5	21	73 000	88 000	10 500	7 600	4 700	0,575	T4CB055	–
	100	21	18	22,75	109 000	109 000	16 200	8 100	4 600	0,728	30211-XL	T3DB055
	100	25	19	26,75	124 000	130 000	20 100	7 800	4 150	0,88	32211-B-XL	–
	100	25	21	26,75	130 000	137 000	21 200	7 900	4 100	0,87	32211-XL	T3DC055
	100	35	27	35	164 000	194 000	31 500	7 600	4 350	1,17	33211-XL	T3DE055
	105	34,5	29	36	135 000	193 000	24 400	6 600	4 450	1,43	T5ED055	–
	110	39	32	39	176 000	226 000	28 500	6 500	4 350	1,63	T2ED055	–
	115	31	23,5	34	152 000	165 000	25 500	6 600	5 000	1,59	T7FC055-XL	–
	120	29	25	31,5	180 000	175 000	27 000	6 900	4 350	1,63	30311-XL	T2FB055
	120	29	21	31,5	145 000	139 000	21 000	6 500	4 100	1,75	31311-XL	T7FB055
120	43	35	45,5	211 000	270 000	33 500	6 100	4 350	2,39	32311-A	T2FD055	
120	43	35	45,5	194 000	265 000	33 000	5 900	4 450	2,49	32311-B	T5FD055	
60	85	17	14	17	49 000	85 000	9 900	8 300	4 250	0,315	32912	T2BC060
	95	27	21	27	95 000	148 000	18 800	7 300	4 650	0,714	33012	T2CE060
	95	23	17,5	23	97 000	124 000	19 600	8 000	4 350	0,61	32012-X-XL	T4CC060
	100	30	23	30	116 000	171 000	21 500	6 900	3 950	0,918	33112	T3CE060
	100	20	15,5	21	75 000	93 000	11 100	7 200	4 400	0,597	T4CB060	–
	110	38	29	38	169 000	237 000	29 500	6 300	4 050	1,55	33212	T3EE060
	110	22	19	23,75	122 000	123 000	18 400	7 500	4 250	0,95	30212-XL	–
	110	28	21	29,75	151 000	162 000	25 500	7 000	3 900	1,19	32212-B-XL	–
	110	28	24	29,75	158 000	171 000	27 000	7 200	3 850	1,18	32212-XL	T3EC060
	115	39	33	40	189 000	250 000	31 500	6 100	4 050	2,04	T2EE060	–
	115	38	31	39	156 000	223 000	28 000	6 000	4 150	1,82	T5ED060	–
	125	33,5	26	37	181 000	200 000	31 000	6 100	4 700	2,03	T7FC060-XL	–
	130	31	26	33,5	208 000	204 000	31 500	6 300	4 050	2,03	30312-XL	T2FB060
	130	31	22	33,5	173 000	169 000	25 500	6 000	3 800	1,94	31312-XL	T7FB060
	130	46	37	48,5	220 000	300 000	38 000	5 400	4 150	3,1	32312-BA	T5FD060
	130	46	37	48,5	285 000	310 000	51 000	6 100	4 050	2,96	32312-XL	T2FD060

medias ▶ <https://www.schaeffler.de/std/1EFF>



Dimensions					Mounting dimensions										Calculation factors		
d	r ₁ , r ₂	r ₃ , r ₄	a	d ₁	d _a	d _b	D _a	D _a	D _b	C _a	C _b	r _a	r _b	e	Y	Y ₀	
	min.	min.	≈	≈	max.	min.	min.	max.	min.	min.	min.	max.	max.				
55	1	1	15	68,8	61	61	73	74	76	4	3	1	1	0,31	1,94	1,07	
	1,5	1,5	19	74,2	63	62	81	83	86	5	6	1,5	1,5	0,31	1,92	1,06	
	1,5	1,5	20	75,1	63	62	81	83	86	4	5,5	1,5	1,5	0,41	1,48	0,81	
	1,5	1,5	22	76,2	62	62	83	88	91	5	7	1,5	1,5	0,37	1,6	0,88	
	2	2	20	74,3	64	65	85	87	90	5	5,5	2	2	0,45	1,35	0,74	
	2	1,5	21	76	64	64	88	91	94	4	4,5	2	1,5	0,4	1,48	0,81	
	2	1,5	26	78	61	64	85	91	96	4	7,5	2	1,5	0,57	1,05	0,58	
	2	1,5	23	76,7	63	64	87	91	95	4	5,5	2	1,5	0,4	1,48	0,81	
	2	1,5	26	79,4	62	64	85	91	96	6	8	2	1,5	0,4	1,5	0,83	
	4	2,5	31	82,9	63	69	82	95	100	5	7	4	2,5	0,56	1,07	0,59	
	2,5	2,5	27	81,5	65	68	93	100	104	7	7	2,5	2,5	0,35	1,73	0,95	
	3	3	40	88,8	65	72	86	101	109	5	10,5	3	3	0,87	0,69	0,38	
	2,5	2	25	85,4	71	65	104	110	111	4	6,5	2,5	2	0,35	1,74	0,96	
	2,5	2	39	88,5	68	65	94	110	113	4	10,5	2,5	2	0,83	0,73	0,4	
	2,5	2	30	85,6	68	65	99	110	111	5	10,5	2,5	2	0,35	1,74	0,96	
2,5	2	36	89,6	65	65	91	110	112	5	10,5	2,5	2	0,55	1,1	0,6		
60	1	1	16	73,8	66	66	78	79	81	4	3	1	1	0,33	1,81	1	
	1,5	1,5	20	78,6	67	67	85	88	90	5	6	1,5	1,5	0,33	1,83	1,01	
	1,5	1,5	21	79,6	67	67	85	88	91	4	5,5	1,5	1,5	0,43	1,39	0,77	
	1,5	1,5	24	81,9	67	67	88	93	96	5	7	1,5	1,5	0,4	1,51	0,83	
	2	2	22	79,9	68	70	89	92	95	4	5,5	2	2	0,47	1,27	0,7	
	2	1,5	28	86,2	68	69	93	101	105	6	9	2	1,5	0,4	1,48	0,82	
	2	1,5	22	82,4	70	69	96	101	103	4	4,5	2	1,5	0,41	1,48	0,81	
	2	1,5	29	85,6	69	69	92	104	105	5	8,5	2	1,5	0,57	1,05	0,58	
	2	1,5	25	83,2	69	69	95	101	104	4	5,5	2	1,5	0,4	1,48	0,81	
	2,5	2,5	28	86,1	70	73	98	103	108	7	7	2,5	2,5	0,33	1,8	0,99	
	4	2,5	33	90,9	69	76	91	103	110	6	8	4	2,5	0,53	1,13	0,62	
	3	3	42	95,8	71	78	94	111	119	6	11	3	3	0,82	0,73	0,4	
	3	2,5	27	92,2	77	72	112	118	120	5	7,5	3	2,5	0,35	1,74	0,96	
	3	2,5	41	96,2	73	72	103	118	123	5	11,5	3	2,5	0,83	0,73	0,4	
	3	2,5	39	97	71	72	100	118	122	6	11,5	3	2,5	0,55	1,1	0,6	
3	2,5	32	92,5	74	72	107	118	120	6	11,5	3	2,5	0,35	1,74	0,96		



Tapered roller bearings

Single row to DIN/ISO

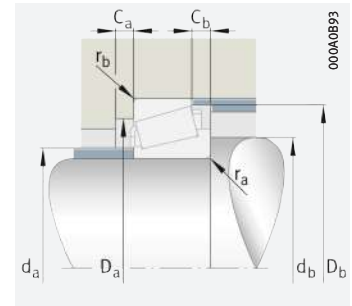
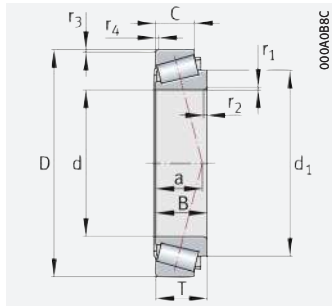

Mounting dimensions

d = 65 – 70 mm

Main dimensions					Basic load ratings		Fatigue limit load	Limiting speed	Speed rating	Mass	Designation	Interchange designation to ISO 10317 and ISO 355
d	D	B	C	T	dyn. Cr	stat. Cor	C _{ur}	n _G	n _{thr}	m	▶ 573 1.12 ▶ 574 1.13 X-life ▶ 559	
					N	N	N	min ⁻¹	min ⁻¹	≈ kg		
65	90	17	14	17	49 500	88 000	10 200	7 800	4 000	0,326		32913
	100	27	21	27	100 000	161 000	20 300	6 900	4 300	0,766	33013	T2CE065
	100	23	17,5	23	97 000	125 000	20 400	7 500	4 150	0,66	32013-X-XL	T4CC065
	105	20	15,5	21	80 000	102 000	12 300	6 800	4 100	0,65	T4CB065	–
	110	34	26,5	34	149 000	225 000	28 500	6 200	3 650	1,31	33113	T3DE065
	120	23	20	24,75	142 000	143 000	21 500	6 800	3 850	1,16	30213-XL	T3EB065
	120	31	23	32,75	174 000	185 000	29 000	6 500	3 750	1,53	32213-B-XL	–
	120	31	27	32,75	185 000	202 000	32 000	6 500	3 600	1,57	32213-XL	T3EC065
	120	41	32	41	242 000	285 000	46 500	6 300	3 750	2,02	33213-XL	T3EE065
	120	38	31	39	161 000	235 000	29 500	5 700	3 950	1,91	T5ED065	–
	130	33,5	26	37	186 000	211 000	32 500	5 700	4 450	2,15	T7FC065-XL	–
	140	33	28	36	196 000	228 000	27 000	5 300	3 850	2,4	30313-A	T2GB065
	140	33	23	36	193 000	188 000	28 500	5 500	3 650	2,39	31313-XL	T7GB065
	140	48	39	51	248 000	340 000	43 000	5 000	3 850	3,7	32313-BA	T5GD065
140	48	39	51	320 000	350 000	56 000	5 600	3 750	3,61	32313-XL	T2GD065	
70	100	20	16	20	85 000	116 000	18 300	7 600	3 800	0,494	32914-XL	T2BC070
	110	31	25,5	31	136 000	223 000	28 500	6 200	3 850	1,21	33014	T2CE070
	110	25	19	25	123 000	159 000	26 000	6 900	3 800	0,88	32014-X-XL	T4CC070
	110	20	15,5	21	82 000	108 000	13 100	6 500	3 800	0,691	T4CB070	–
	120	37	29	37	174 000	260 000	33 000	5 700	3 500	1,71	33114	T3DE070
	125	41	32	41	210 000	300 000	38 000	5 500	3 550	2,12	33214	T3EE070
	125	24	21	26,25	155 000	162 000	24 500	6 400	3 700	1,31	30214-XL	T3EB070
	125	31	23,5	33,25	179 000	196 000	31 000	6 100	3 550	1,64	32214-B-XL	–
	125	31	27	33,25	194 000	216 000	34 000	6 200	3 450	1,81	32214-XL	T3EC070
	130	42	35	43	225 000	310 000	39 000	5 300	3 550	2,52	T2ED070	–
	130	40	34	42	195 000	295 000	37 500	5 200	3 550	2,51	T5ED070	–
	140	35,5	27	39	208 000	237 000	37 500	5 300	4 150	2,68	T7FC070-XL	–
	150	35	30	38	223 000	260 000	30 500	4 900	3 650	3,02	30314-A	T2GB070
	150	35	25	38	221 000	219 000	33 000	5 200	3 450	2,96	31314-XL	T7GB070
	150	51	42	54	285 000	395 000	48 500	4 650	3 600	4,51	32314-BA	T5GD070
	150	51	42	54	370 000	410 000	65 000	5 200	3 500	4,39	32314-XL	T2GD070

medias ▶ <https://www.schaeffler.de/std/1F00>



Dimensions					Mounting dimensions									Calculation factors		
d	r ₁ , r ₂	r ₃ , r ₄	a	d ₁	d _a	d _b	D _a	D _a	D _b	C _a	C _b	r _a	r _b	e	Y	Y ₀
	min.	min.	≈	≈	max.	min.	min.	max.	min.	min.	min.	max.	max.			
65	1	1	17	79	71	71	83	84	86	4	3	1	1	0,35	1,7	0,93
	1,5	1,5	21	84,6	72	72	89	93	96	5	6	1,5	1,5	0,35	1,72	0,95
	1,5	1,5	23	85,1	72	72	90	93	97	4	5,5	1,5	1,5	0,46	1,31	0,72
	2	2	24	84,4	73	75	94	97	100	4	5,5	2	2	0,5	1,2	0,66
	1,5	1,5	26	89,6	73	72	96	103	106	6	7,5	1,5	1,5	0,39	1,55	0,85
	2	1,5	24	90,6	77	74	106	111	113	4	4,5	2	1,5	0,4	1,48	0,81
	2	1,5	31	92,1	74	74	101	111	114	5	9,5	2	1,5	0,56	1,07	0,59
	2	1,5	27	91,6	76	74	104	111	115	4	5,5	2	1,5	0,4	1,48	0,81
	2	1,5	30	93,1	74	74	102	111	115	6	9	2	1,5	0,39	1,54	0,85
	4	2,5	35	95,9	74	80	95	108	115	6	8	4	2,5	0,56	1,07	0,59
	3	3	45	101	75	83	98	116	124	5	11	3	3	0,87	0,69	0,38
	3	2,5	29	99,6	83	77	122	128	130	5	8	3	2,5	0,35	1,74	0,96
	3	2,5	44	103,5	79	77	111	128	132	5	13	3	2,5	0,83	0,73	0,4
	3	2,5	42	104,3	77	77	109	128	133	6	12	3	2,5	0,55	1,1	0,6
3	2,5	35	99,6	80	77	117	128	130	6	12	3	2,5	0,35	1,74	0,96	
70	1	1	18	85,9	76	76	93	94	96	4	4	1	1	0,32	1,9	1,05
	1,5	1,5	23	91	78	77	99	103	105	5	5,5	1,5	1,5	0,28	2,11	1,16
	1,5	1,5	24	91,7	78	77	98	103	105	5	6	1,5	1,5	0,43	1,38	0,76
	2	2	23	90,2	78	80	100	102	105	4	5,5	2	2	0,46	1,3	0,72
	2	1,5	28	96	79	79	104	111	115	6	8	2	1,5	0,38	1,58	0,87
	2	1,5	31	97,5	79	79	107	116	120	7	9	2	1,5	0,41	1,47	0,81
	2	1,5	25	95,2	81	79	110	116	118	4	5	2	1,5	0,42	1,43	0,79
	2	1,5	34	97,5	78	79	105	116	120	5	9,5	2	1,5	0,59	1,02	0,56
	2	1,5	28	96,4	80	79	108	116	119	4	6	2	1,5	0,42	1,43	0,79
	3	2,5	31	99,6	80	85	111	119	123	7	8	3	2,5	0,33	1,8	0,99
	4	2,5	37	103,2	81	87	105	119	124	7	8	4	2,5	0,52	1,15	0,63
	3	3	47	108,8	81	90	106	126	133	6	12	3	3	0,87	0,69	0,38
	3	2,5	30	106,6	89	82	130	138	140	5	8	3	2,5	0,35	1,74	0,96
	3	2,5	47	110,4	84	82	118	138	141	5	13	3	2,5	0,83	0,73	0,4
3	2,5	44	111,9	83	82	117	138	143	7	12	3	2,5	0,55	1,1	0,6	
3	2,5	37	106,4	86	82	125	138	140	6	12	3	2,5	0,35	1,74	0,96	



Tapered roller bearings

Single row to DIN/ISO

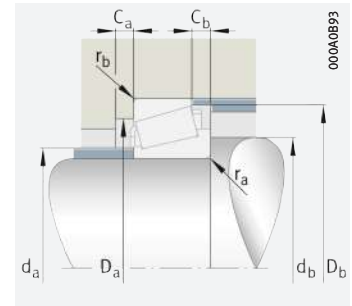
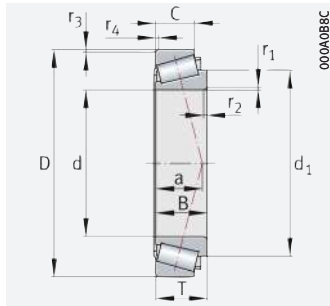

Mounting dimensions

d = 75 – 80 mm

Main dimensions					Basic load ratings		Fatigue limit load	Limiting speed	Speed rating	Mass	Designation	Interchange designation to ISO 10317 and ISO 355
d	D	B	C	T	dyn. Cr	stat. Cor	C _{ur}	n _G	n _{thr}	m	▶ 573 1.12 ▶ 574 1.13 X-life ▶ 559	
					N	N	N	min ⁻¹	min ⁻¹	≈ kg		
75	105	20	16	20	74 000	124 000	15 000	6 600	3 550	0,519		32915
	115	31	25,5	31	139 000	232 000	30 000	5 900	3 700	1,16	33015	T2CE075
	115	25	19	25	124 000	165 000	26 500	6 500	3 600	0,92	32015-X-XL	T4CC075
	115	20	15,5	21	83 000	113 000	13 700	6 100	3 600	0,722	T4CB075	–
	125	37	29	37	178 000	275 000	34 500	5 400	3 300	1,81	33115	T3DE075
	130	25	22	27,25	160 000	169 000	26 000	6 100	3 600	1,4	30215-XL	T4DB075
	130	31	27	33,25	201 000	227 000	36 000	5 900	3 250	1,76	32215-XL	T4DC075
	130	41	31	41	245 000	310 000	51 000	5 700	3 350	2,25	33215-XL	T3EE075
	135	42	35	43	233 000	330 000	41 000	5 100	3 350	2,66	T2ED075	–
	135	40	34	42	200 000	310 000	39 000	5 000	3 400	2,66	T5ED075	–
	150	38	29	42	238 000	275 000	42 500	4 950	3 950	3,22	T7FC075-XL	–
	160	37	31	40	250 000	295 000	34 500	4 600	3 400	3,9	30315-A	T2GB075
	160	37	26	40	240 000	236 000	34 500	4 850	3 300	3,46	31315-XL	T7GB075
	160	55	45	58	360 000	475 000	57 000	4 450	3 300	5,8	32315-A	T2GD075
160	55	45	58	330 000	470 000	54 000	4 350	3 400	5,56	32315-B	T5GD075	
80	110	20	16	20	77 000	132 000	16 000	6 300	3 350	0,56	32916	T2BC080
	125	29	22	29	162 000	212 000	34 000	6 000	3 450	1,29	32016-X-XL	T3CC080
	125	36	29,5	36	208 000	290 000	48 500	5 900	3 550	1,63	33016-XL	T2CE080
	125	22,5	17,5	24	114 000	150 000	17 800	5 600	3 450	1	T4CB080	–
	130	37	29	37	188 000	300 000	37 000	5 200	3 050	1,91	33116	T3DE080
	140	26	22	28,25	184 000	193 000	28 500	5 700	3 400	1,68	30216-XL	T3EB080
	140	33	28	35,25	234 000	265 000	40 500	5 500	3 050	2,15	32216-XL	T3EC080
	140	46	35	46	295 000	385 000	61 000	5 300	3 150	2,98	33216-XL	T3EE080
	140	40	34	42	204 000	320 000	40 000	4 800	3 250	2,75	T5ED080	–
	145	45	38	46	265 000	370 000	45 500	4 750	3 200	3,2	T2ED080	–
	160	41	31	45	270 000	315 000	48 000	4 600	3 750	3,98	T7FC080-XL	–
	170	39	33	42,5	285 000	345 000	39 500	4 250	3 200	4,37	30316-A	T2GB080
	170	39	27	42,5	270 000	270 000	38 500	4 550	3 150	4,16	31316-XL	T7GB080
	170	58	48	61,5	355 000	510 000	61 000	4 100	3 300	7,02	32316-B	T5GD080
170	58	48	61,5	475 000	540 000	82 000	4 550	3 150	7,02	32316-XL	T2GD080	

medias ▶ <https://www.schaeffler.de/std/1F01>



Dimensions					Mounting dimensions								Calculation factors			
d	r ₁ , r ₂	r ₃ , r ₄	a	d ₁	d _a	d _b	D _a	D _a	D _b	C _a	C _b	r _a	r _b	e	Y	Y ₀
	min.	min.	≈	≈	max.	min.	min.	max.	min.	min.	min.	max.	max.			
75	1	1	19	90,5	81	81	98	99	101	4	4	1	1	0,33	1,8	0,99
	1,5	1,5	23	96,4	83	82	104	108	110	6	5,5	1,5	1,5	0,3	2,01	1,11
	1,5	1,5	26	97	83	82	103	108	110	5	6	1,5	1,5	0,46	1,31	0,72
	2	2	25	94,6	83	85	104	107	110	4	5,5	2	2	0,48	1,24	0,68
	2	1,5	30	101,9	84	84	109	116	120	6	8	2	1,5	0,4	1,51	0,83
	2	1,5	27	100,4	86	84	115	121	124	4	5	2	1,5	0,43	1,38	0,76
	2	1,5	30	101,6	85	84	115	121	124	4	6	2	1,5	0,43	1,38	0,76
	2	1,5	32	103,9	83	84	111	121	125	7	10	2	1,5	0,43	1,4	0,77
	3	2,5	32	103,4	86	89	116	124	128	7	8	3	2,5	0,35	1,73	0,95
	5	2,5	38	108,5	85	92	109	124	129	6	8	5	2,5	0,55	1,1	0,6
	3	3	51	116,6	87	96	114	136	143	6	13	3	3	0,87	0,69	0,38
	3	2,5	32	114	95	87	139	148	149	5	9	3	2,5	0,35	1,74	0,96
	3	2,5	50	117,6	91	87	127	148	151	6	14	3	2,5	0,83	0,73	0,4
	3	2,5	39	114	91	87	133	148	149	7	13	3	2,5	0,35	1,74	0,96
3	2,5	47	119	90	87	124	148	151	7	14	3	2,5	0,55	1,1	0,6	
80	1	1	20	96,1	86	86	102	104	106	4	4	1	1	0,35	1,71	0,94
	1,5	1,5	27	104,2	89	87	112	117	120	6	7	1,5	1,5	0,42	1,42	0,78
	1,5	1,5	26	103,2	90	87	112	117	119	6	6,5	1,5	1,5	0,28	2,16	1,19
	2	2	26	101	86	90	113	115	120	5	6,5	2	2	0,45	1,33	0,73
	2	1,5	31	106,6	89	89	114	121	126	6	8	2	1,5	0,42	1,44	0,79
	2,5	2	28	106,4	91	90	124	130	132	4	6	2,5	2	0,42	1,43	0,79
	2,5	2	31	107,7	90	90	122	130	134	5	7	2,5	2	0,42	1,43	0,79
	2,5	2	35	112,2	89	90	119	130	135	7	11	2,5	2	0,43	1,41	0,78
	5	3	40	113,5	89	97	113	128	124	6	8	5	3	0,57	1,05	0,58
	3	2,5	33	110,3	92	95	125	134	137	7	8	3	2,5	0,32	1,88	1,03
	3	3	54	124,3	93	103	121	146	152	7	14	3	3	0,87	0,69	0,38
	3	2,5	34	121,7	102	92	148	158	159	5	9,5	3	2,5	0,35	1,74	0,96
	3	2,5	53	124,4	97	92	134	158	159	6	15	3	2,5	0,83	0,73	0,4
	3	2,5	49	126,9	96	92	130	158	160	7	13,5	3	2,5	0,55	1,1	0,6
3	2,5	42	120,6	98	92	142	158	159	7	13,5	3	2,5	0,35	1,74	0,96	



Tapered roller bearings

Single row to DIN/ISO

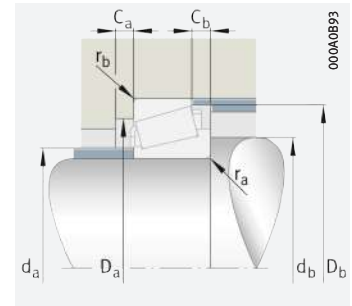
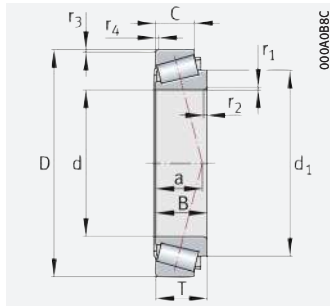

Mounting dimensions

d = 85 – 90 mm

Main dimensions					Basic load ratings		Fatigue limit load	Limiting speed	Speed rating	Mass	Designation	Interchange designation to ISO 10317 and ISO 355
d	D	B	C	T	dyn. C_r	stat. C_{0r}	C_{ur}	n_G	$n_{\theta r}$	m	▶ 573 1.12 ▶ 574 1.13 X-life ▶ 559	
					N	N	N	min^{-1}	min^{-1}	≈ kg		
85	120	23	18	23	95 000	160 000	20 000	5 700	3 250	0,778		32917
	130	36	29,5	36	184 000	315 000	39 500	5 100	3 300	1,89	33017	T2CE085
	130	29	22	29	167 000	224 000	35 500	5 700	3 250	1,36	32017-X-XL	T4CC085
	130	22,5	17,5	24	116 000	157 000	18 400	5 400	3 300	1,05	T4CB085	–
	140	41	32	41	221 000	350 000	43 000	4 750	2 950	2,54	33117	T3DE085
	145	40	34	42	210 000	340 000	41 500	4 600	3 050	2,87	T5ED085	–
	150	49	37	49	295 000	435 000	53 000	4 500	3 050	3,58	33217	T3EE085
	150	28	24	30,5	212 000	226 000	33 000	5 300	3 250	2,13	30217-XL	T3EB085
	150	36	30	38,5	270 000	305 000	46 500	5 200	2 950	2,71	32217-XL	T3EC085
	150	46	38	46	275 000	395 000	48 000	4 600	3 050	3,35	T2ED085	–
	170	45	33	48	310 000	365 000	55 000	4 350	3 550	4,83	T7FC085-XL	–
	180	41	28	44,5	255 000	300 000	34 000	3 900	3 000	4,88	31317	T7GB085
	180	41	34	44,5	310 000	375 000	42 000	4 050	3 100	5,07	30317-A	T2GB085
	180	60	49	63,5	480 000	590 000	90 000	4 250	3 000	7,75	32317-B-XL	T5GD085
180	60	49	63,5	510 000	580 000	88 000	4 300	3 000	7,4	32317-XL	T2GD085	
90	125	23	18	23	99 000	171 000	21 000	5 500	3 050	0,918	32918	T2BC090
	135	22,5	17,5	24	119 000	164 000	18 900	5 100	3 100	1,1	T4CB090	–
	140	39	32,5	39	216 000	365 000	45 000	4 750	3 150	2,26	33018	T2CE090
	140	32	24	32	195 000	255 000	40 000	5 400	3 200	1,76	32018-X-XL	T3CC090
	150	45	35	45	315 000	425 000	66 000	4 900	2 800	3,13	33118-XL	T3DE090
	150	40	34	42	214 000	355 000	43 000	4 450	2 900	2,99	T5ED090	–
	155	46	38	46	280 000	410 000	49 000	4 400	2 900	3,5	T2ED090	–
	160	55	42	55	345 000	530 000	64 000	4 200	2 950	4,76	33218	T3FE090
	160	30	26	32,5	239 000	260 000	37 500	5 000	3 050	2,61	30218-XL	T3FB090
	160	40	34	42,5	310 000	360 000	55 000	4 800	2 850	3,43	32218-XL	T3FC090
	190	43	30	46,5	275 000	325 000	35 500	3 700	2 900	5,45	31318	T7GB090
	190	43	36	46,5	330 000	395 000	43 500	3 850	3 050	5,7	30318-A	T2GB090
	190	64	53	67,5	435 000	630 000	73 000	3 650	2 850	9,29	32318-B	–
	190	64	53	67,5	580 000	660 000	98 000	4 050	2 750	8,21	32318-XL	T2GD090

medias ▶ <https://www.schaeffler.de/std/1F02>



Dimensions					Mounting dimensions									Calculation factors		
d	r ₁ , r ₂	r ₃ , r ₄	a	d ₁	d _a	d _b	D _a	D _a	D _b	C _a	C _b	r _a	r _b	e	Y	Y ₀
	min.	min.	≈	≈	max.	min.	min.	max.	min.	min.	min.	max.	max.			
85	1,5	1,5	21	102,6	92	92	111	113	115	5	5	1,5	1,5	0,33	1,83	1,01
	1,5	1,5	27	108,5	94	92	118	122	125	6	6,5	1,5	1,5	0,29	2,06	1,13
	1,5	1,5	29	109,1	94	92	117	122	125	6	7	1,5	1,5	0,44	1,36	0,75
	2	2	27	106,1	91	95	118	120	125	5	6,5	2	2	0,47	1,27	0,7
	2,5	2	33	114,7	95	95	122	130	135	7	9	2,5	2	0,41	1,48	0,81
	5	3	39	118,5	96	103	120	133	139	6	8	5	3	0,52	1,14	0,63
	2,5	2	37	117,6	95	95	128	140	144	7	12	2,5	2	0,42	1,43	0,79
	2,5	2	30	112,9	97	95	132	140	141	5	6,5	2,5	2	0,42	1,43	0,79
	2,5	2	34	114,7	96	95	130	140	142	5	8,5	2,5	2	0,42	1,43	0,79
	3	3	34	115,5	97	100	130	138	142	5	7	3	3	0,33	1,8	0,99
	4	4	55	132	100	110	131	153	161	7	15	4	4	0,8	0,75	0,41
	4	3	56	129,3	103	99	143	166	169	6	16,5	4	3	0,83	0,73	0,4
	3	3	36	127,6	107	99	156	166	167	6	10,5	3	3	0,35	1,74	0,96
	4	3	52	133,5	102	99	138	166	169	7	14,5	4	3	0,55	1,1	0,6
	4	3	44	127,6	103	99	150	166	167	8	14,5	4	3	0,35	1,74	0,96
90	1,5	1,5	22	107,8	97	97	116	131	120	5	5	1,5	1,5	0,34	1,75	0,96
	2	2	30	111,1	96	100	123	125	130	5	6,5	2	2	0,49	1,21	0,67
	2	1,5	28	116	100	99	127	131	135	7	6,5	2	1,5	0,27	2,23	1,23
	2	1,5	30	115,8	100	99	125	131	134	6	8	2	1,5	0,42	1,42	0,78
	2,5	2	36	121,8	100	100	130	140	144	7	10	2,5	2	0,4	1,51	0,83
	5	3	41	123,7	100	107	124	138	144	6	8	5	3	0,55	1,1	0,6
	3	3	34	120,5	102	106	135	143	147	6	8	3	3	0,33	1,84	1,01
	2,5	2	41	125,8	101	100	135	150	154	9	13	2,5	2	0,42	1,43	0,78
	2,5	2	32	120	103	100	140	150	150	5	6,5	2,5	2	0,42	1,43	0,79
	2,5	2	36	122,1	102	100	138	150	152	5	8,5	2,5	2	0,42	1,43	0,79
	4	3	58	135,9	109	104	151	176	179	6	16,5	4	3	0,83	0,73	0,4
	4	3	37	135	113	104	165	176	176	6	10,5	4	3	0,35	1,74	0,96
	4	3	55	141,8	108	104	146	176	180	8	14,5	4	3	0,55	1,1	0,6
	4	3	47	133	108	104	157	176	177	8	14,5	4	3	0,35	1,74	0,96



Tapered roller bearings

Single row to DIN/ISO

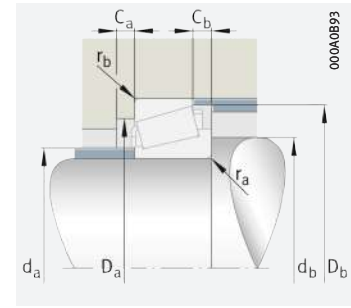
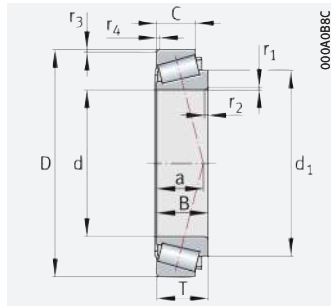

Mounting dimensions

d = 95 – 100 mm

Main dimensions					Basic load ratings		Fatigue limit load C_{ur} N	Limiting speed n_G min^{-1}	Speed rating $n_{\theta r}$ min^{-1}	Mass m \approx kg	Designation ▶ 573 1.12 ▶ 574 1.13 X-life ▶ 559	Interchange designation to ISO 10317 and ISO 355
d	D	B	C	T	dyn. C_r N	stat. C_{0r} N						
95	130	23	18	23	102 000	181 000	22 000	5 300	2 900	0,964	32919	T2BC095
	140	22,5	17,5	24	114 000	167 000	19 100	4 950	2 950	1,15	T4CB095	–
	145	32	24	32	201 000	275 000	42 500	5 100	3 000	1,86	32019-X-XL	T4CC095
	145	39	32,5	39	260 000	380 000	60 000	5 000	3 000	2,57	33019-XL	T2CE095
	155	40	34	42	218 000	365 000	44 500	4 250	2 800	3,15	T5ED095	–
	160	49	38	49	305 000	490 000	59 000	4 150	2 700	4,04	33119	T3EE095
	160	46	38	46	285 000	430 000	51 000	4 250	2 750	3,76	T2ED095	–
	170	58	44	58	375 000	560 000	66 000	3 950	2 850	5,55	33219	T3FE095
	170	32	27	34,5	265 000	285 000	41 500	4 700	2 950	3,13	30219-XL	T3FB095
	170	43	37	45,5	355 000	420 000	63 000	4 500	2 700	4,21	32219-XL	T3FC095
	180	45	33	49	325 000	400 000	59 000	4 000	3 300	5,23	T7FC095-XL	–
	200	45	38	49,5	360 000	440 000	47 500	3 650	2 950	6,78	30319-A	T2GB095
	200	45	32	49,5	305 000	370 000	40 000	3 500	2 800	6,45	31319-A	T7GB095
	200	67	55	71,5	570 000	690 000	102 000	3 750	2 700	10,9	32319-B-XL	–
	200	67	55	71,5	620 000	710 000	105 000	3 850	2 600	10	32319-XL	T2GD095
100	140	25	20	25	126 000	211 000	24 900	4 900	2 750	1,17	32920	T2CC100
	145	22,5	17,5	24	119 000	179 000	20 200	4 750	2 800	1,21	T4CB100	–
	150	39	32,5	39	225 000	395 000	47 500	4 450	2 900	2,42	33020	T2CE100
	150	32	24	32	205 000	285 000	43 500	4 950	2 900	1,94	32020-X-XL	T4CC100
	160	40	34	42	275 000	395 000	60 000	4 550	2 650	3,51	T5ED100-XL	–
	165	52	40	52	325 000	540 000	64 000	4 000	2 650	4,46	33120	T3EE100
	165	46	39	47	300 000	470 000	56 000	4 100	2 600	4,25	T2EE100	–
	180	63	48	63	430 000	660 000	77 000	3 700	2 650	6,71	33220	T3FE100
	180	34	29	37	295 000	325 000	46 500	4 400	2 850	3,76	30220-XL	T3FB100
	180	46	39	49	400 000	475 000	71 000	4 250	2 600	5,12	32220-XL	T3FC100
	215	47	39	51,5	410 000	500 000	54 000	3 400	2 750	8,3	30320-A	T2GB100
	215	51	35	56,5	385 000	480 000	51 000	3 200	2 550	8,81	31320-X	T7GB100
	215	73	60	77,5	680 000	780 000	114 000	3 550	2 500	13,4	32320-B-XL	–
	215	73	60	77,5	610 000	840 000	94 000	3 250	2 360	12,9	32320-A	T2GD100

medias ▶ <https://www.schaeffler.de/std/1F03>



Dimensions					Mounting dimensions									Calculation factors		
d	r ₁ , r ₂	r ₃ , r ₄	a	d ₁	d _a	d _b	D _a	D _a	D _b	C _a	C _b	r _a	r _b	e	Y	Y ₀
	min.	min.	≈	≈	max.	min.	min.	max.	min.	min.	min.	max.	max.			
95	1,5	1,5	24	113	102	102	121	123	125	5	5	1,5	1,5	0,36	1,68	0,92
	2	2	29	117,2	104	107	129	130	135	5	6,5	2	2	0,45	1,32	0,73
	2	1,5	32	121,4	105	104	130	136	140	6	8	2	1,5	0,44	1,36	0,75
	2	1,5	29	120,8	104	104	131	136	139	7	6,5	2	1,5	0,28	2,16	1,19
	5	3	43	128,8	104	112	128	143	150	6	8	5	3	0,57	1,06	0,58
	2,5	2	38	128,7	106	105	138	150	154	8	11	2,5	2	0,39	1,54	0,85
	3	3	35	125,6	107	111	140	148	152	8	8	3	3	0,34	1,77	0,97
	3	2,5	43	132	107	107	144	158	163	9	14	3	2,5	0,41	1,47	0,81
	3	2,5	34	127,3	110	107	149	158	159	5	7,5	3	2,5	0,42	1,43	0,79
	3	2,5	39	129	108	107	145	158	161	5	8,5	3	2,5	0,42	1,43	0,79
	4	4	61	142,4	108	119	138	164	172	7	16	4	4	0,87	0,69	0,38
	4	3	40	139	118	109	172	186	184	6	11,5	4	3	0,35	1,74	0,96
	4	3	62	142,5	114	109	157	186	187	6	17,5	4	3	0,83	0,73	0,4
	4	3	58	149,3	115	109	153	186	189	8	16,5	4	3	0,55	1,1	0,6
	4	3	49	142	115	109	166	186	186	8	16,5	4	3	0,35	1,74	0,96
100	1,5	1,5	24	120,6	109	107	131	131	135	5	5	1,5	1,5	0,33	1,82	1
	3	3	30	122,7	109	112	133	133	140	5	6,5	3	3	0,47	1,27	0,7
	2	1,5	29	124,7	108	109	135	141	143	7	6,5	2	1,5	0,29	2,09	1,15
	2	1,5	33	126,3	109	109	134	141	144	6	8	2	1,5	0,46	1,31	0,72
	5	3	42	133,8	110	117	135	146	154	6	8	5	3	0,53	1,14	0,63
	2,5	2	41	134,7	111	110	142	155	159	8	12	2,5	2	0,41	1,48	0,81
	3	3	35	131,3	112	116	145	151	157	8	8	3	3	0,32	1,88	1,04
	3	2,5	46	140	112	112	151	168	172	10	15	3	2,5	0,4	1,48	0,82
	3	2,5	36	134,2	116	112	157	168	168	5	8	3	2,5	0,42	1,43	0,79
	3	2,5	42	136,5	114	112	154	168	171	5	10	3	2,5	0,42	1,43	0,79
	4	3	42	151	127	114	184	201	197	6	12,5	4	3	0,35	1,74	0,96
	4	3	68	159,5	121	114	168	201	202	7	21,5	4	3	0,83	0,73	0,4
	4	3	53	152	123	114	177	201	200	8	17,5	4	3	0,35	1,74	0,96
	4	3	62	155,9	117	114	166	201	203	8	17,5	4	3	0,53	1,13	0,62



Tapered roller bearings

Single row to DIN/ISO

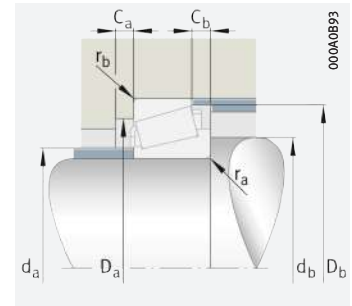
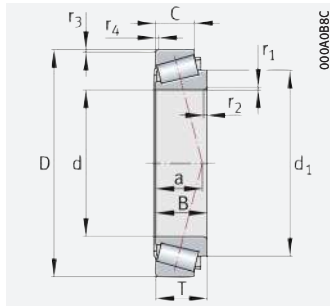

Mounting dimensions

d = 105 – 120 mm

Main dimensions					Basic load ratings		Fatigue limit load	Limiting speed	Speed rating	Mass	Designation	Interchange designation to ISO 10317 and ISO 355
d	D	B	C	T	dyn. C_r	stat. C_{0r}	C_{ur}	n_G	$n_{\theta r}$	m	▶ 573 1.12 ▶ 574 1.13 X-life ▶ 559	
					N	N	N	min ⁻¹	min ⁻¹	≈ kg		
105	145	25	20	25	128 000	217 000	25 500	4 700	2 650	1,15		32921
	150	22,5	17,5	24	121 000	185 000	20 700	4 600	2 650	1,25	T4CB105	–
	160	43	34	43	265 000	450 000	53 000	4 150	2 850	3,06	33021	T2DE105
	160	35	26	35	238 000	330 000	49 500	4 650	2 800	2,45	32021-X-XL	T4DC105
	170	46	39	47	315 000	495 000	58 000	3 950	2 500	4,13	T2EE105	–
	175	56	44	56	360 000	600 000	71 000	3 750	2 600	5,44	33121	T3EE105
	190	68	52	68	495 000	760 000	88 000	3 500	2 480	8,38	33221	T3FE105
	190	36	30	39	330 000	370 000	52 000	4 150	2 700	4,46	30221-XL	T3FB105
	190	50	43	53	455 000	550 000	82 000	4 000	2 550	6,3	32221-XL	T3FC105
	225	49	41	53,5	530 000	560 000	76 000	3 600	2 550	10,5	30321-XL	T2GB105
	225	53	36	58	480 000	510 000	70 000	3 350	2 440	10	31321-X-XL	T7GB105
	225	77	63	81,5	670 000	930 000	103 000	3 100	2 220	15,9	32321-A	T2GD105
110	150	25	20	25	133 000	231 000	27 000	4 550	2 500	1,41	32922	T2CC110
	160	25,5	19,5	27	148 000	222 000	24 800	4 300	2 600	1,69	T4CB110	–
	170	47	37	47	295 000	520 000	61 000	3 950	2 750	3,89	33022	T2DE110
	170	38	29	38	285 000	395 000	59 000	4 350	2 650	3,06	32022-X-XL	T4DC110
	175	46	39	47	325 000	520 000	60 000	3 800	2 400	4,27	T2EE110	–
	180	56	43	56	440 000	630 000	95 000	4 000	2 460	5,64	33122-XL	T3EE110
	200	38	32	41	375 000	420 000	59 000	3 950	2 550	5,68	30222-XL	T3FB110
	200	53	46	56	490 000	590 000	86 000	3 800	2 410	7,2	32222-XL	T3FC110
	240	50	42	54,5	570 000	600 000	79 000	3 350	2 340	11	30322-XL	T2GB110
	240	57	38	63	550 000	590 000	78 000	3 100	2 250	12,2	31322-X-XL	T7GB110
	240	80	65	84,5	740 000	1 020 000	126 000	2 900	2 030	19	32322-A	T2GD110
	120	165	29	23	29	176 000	305 000	35 000	4 100	2 370	1,82	32924
170		25	19,5	27	181 000	238 000	33 000	4 400	2 420	1,74	T4CB120-XL	–
180		48	38	48	310 000	560 000	65 000	3 700	2 600	4,53	33024	T2DE120
180		38	29	38	295 000	420 000	62 000	4 050	2 460	3,29	32024-X-XL	T4DC120
190		49	41	50	360 000	590 000	67 000	3 500	2 230	5,28	T2EE120	–
200		62	48	62	460 000	770 000	87 000	3 250	2 160	7,68	33124	T3FE120
215		40	34	43,5	395 000	445 000	62 000	3 650	2 470	6,26	30224-XL	T4FB120
215		58	50	61,5	570 000	730 000	105 000	3 450	2 150	9,31	32224-XL	T4FD120
260		62	42	68	640 000	700 000	92 000	2 850	2 020	15,8	31324-X-XL	T7GB120
260		86	69	90,5	670 000	970 000	118 000	2 750	2 060	21,1	32324	–
260		55	46	59,5	560 000	700 000	83 000	2 800	2 150	14,2	30324-A	T2GB120

medias ▶ <https://www.schaeffler.de/std/1F04>



Dimensions					Mounting dimensions										Calculation factors		
d	r ₁ , r ₂	r ₃ , r ₄	a	d ₁	d _a	d _b	D _a	D _a	D _b	C _a	C _b	r _a	r _b	e	Y	Y ₀	
	min.	min.	≈	≈	max.	min.	min.	max.	min.	min.	min.	max.	max.				
105	1,5	1,5	25	125	114	112	135	136	140	5	5	1,5	1,5	0,34	1,75	0,96	
	3	3	32	127,3	114	116	138	138	145	5	6,5	3	3	0,49	1,22	0,67	
	2,5	2	31	131,5	116	115	145	150	153	7	9	2,5	2	0,28	2,12	1,17	
	2,5	2	35	133,7	116	115	143	150	154	6	9	2,5	2	0,44	1,35	0,74	
	3	3	36	136,3	117	121	150	158	163	8	8	3	3	0,33	1,83	1,01	
	2,5	2	43	142	116	115	150	165	169	9	12	2,5	2	0,4	1,48	0,82	
	3	2,5	49	148	117	117	159	178	182	10	16	3	2,5	0,4	1,49	0,82	
	3	2,5	38	141,6	122	117	165	178	177	6	9	3	2,5	0,42	1,43	0,79	
	3	2,5	45	143,6	120	117	161	178	180	5	10	3	2,5	0,42	1,43	0,79	
	4	3	44	154,9	132	119	193	211	206	7	12,5	4	3	0,35	1,74	0,96	
110	1,5	1,5	26	130,9	118	117	140	141	145	5	5	1,5	1,5	0,36	1,69	0,93	
	3	3	32	134	120	122	147	148	154	6	7,5	3	3	0,44	1,36	0,75	
	2,5	2	33	139,2	123	120	152	160	161	7	10	2,5	2	0,29	2,09	1,15	
	2,5	2	37	141,2	122	120	152	160	163	7	9	2,5	2	0,43	1,39	0,77	
	4	3	37	140,9	121	125	155	163	168	8	8	4	3	0,34	1,78	0,98	
	2,5	2	44	147,6	121	120	155	170	174	9	13	2,5	2	0,42	1,43	0,79	
	3	2,5	40	149,3	129	122	174	188	187	6	9	3	2,5	0,42	1,43	0,79	
	3	2,5	46	151,4	126	122	170	188	190	6	10	3	2,5	0,42	1,43	0,79	
	4	3	45	166,6	141	124	206	226	220	8	12,5	4	3	0,35	1,74	0,96	
	4	3	75	176,7	135	124	188	226	224	7	25	4	3	0,83	0,73	0,4	
120	1,5	1,5	29	141	128	127	154	158	160	6	6	1,5	1,5	0,35	1,72	0,95	
	3	3	35	144,6	130	132	157	157	164	5	7,5	3	3	0,47	1,27	0,7	
	2,5	2	36	148,5	132	130	160	170	171	6	10	2,5	2	0,31	1,97	1,08	
	2,5	2	40	151,2	131	130	161	170	173	7	9	2,5	2	0,46	1,31	0,72	
	4	3	39	153,5	133	137	169	177	182	9	9	4	3	0,32	1,86	1,02	
	2,5	2	48	161,4	133	130	172	190	192	9	14	2,5	2	0,4	1,51	0,83	
	3	2,5	44	162	140	132	187	203	201	6	9,5	3	2,5	0,43	1,38	0,76	
	3	2,5	51	164,3	136	132	181	203	204	7	11,5	3	2,5	0,43	1,38	0,76	
	4	3	82	191,5	145	134	203	246	244	9	26	4	3	0,83	0,73	0,4	
	4	3	66	187	148	134	213	246	239	9	21,5	4	3	0,39	1,53	0,84	
4	3	48	183,5	152	134	221	246	237	10	13,5	4	3	0,35	1,74	0,96		



Tapered roller bearings

Single row to DIN/ISO

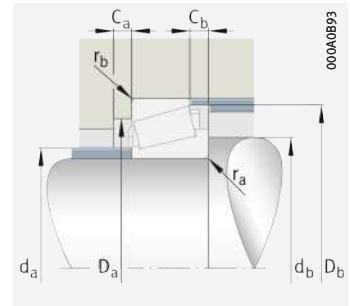
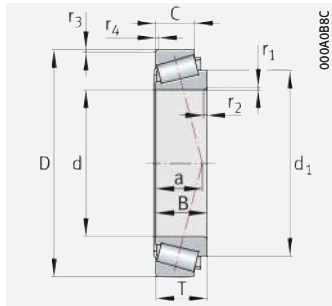

Mounting dimensions

d = 130 – 150 mm

Main dimensions					Basic load ratings		Fatigue limit load	Limiting speed	Speed rating	Mass	Designation	Interchange designation to ISO 10317 and ISO 355
d	D	B	C	T	dyn. C_r	stat. C_{0r}	C_{ur}	n_G	$n_{\theta r}$	m	▶ 573 1.12 ▶ 574 1.13 X-life ▶ 559	
					N	N	N	min ⁻¹	min ⁻¹	≈ kg		
130	180	32	25	32	208 000	370 000	41 500	3 750	2 220	2,4		32926
	185	27	21	29	179 000	275 000	29 500	3 700	2 280	2,27	T4CB130	–
	200	55	43	55	410 000	740 000	83 000	3 250	2 260	6,33	33026	T2EE130
	200	45	34	45	385 000	550 000	79 000	3 650	2 320	4,83	32026-X-XL	T4EC130
	230	40	34	43,75	420 000	470 000	63 000	3 400	2 290	7,08	30226-XL	T4FB130
	230	64	54	67,75	660 000	850 000	120 000	3 200	1 980	11,4	32226-XL	T4FD130
	280	58	49	63,75	770 000	850 000	110 000	2 850	1 870	17	30326-XL	T2GB130
	280	66	44	72	720 000	790 000	101 000	2 650	1 860	19	31326-X-XL	T7GB130
	280	93	78	98,75	830 000	1 120 000	133 000	2 500	1 860	26,7	32326	–
140	190	32	25	32	214 000	395 000	43 000	3 500	2 070	2,6	32928	T2CC140
	195	27	21	29	190 000	305 000	32 000	3 450	2 100	2,43	T4CB140	–
	210	56	44	56	415 000	770 000	85 000	3 100	2 140	6,81	33028	T2DE140
	210	45	34	45	400 000	590 000	84 000	3 450	2 180	5,4	32028-X-XL	T4DC140
	215	52	44	53	430 000	730 000	80 000	3 050	1 860	6,89	T2ED140	–
	250	42	36	45,75	490 000	560 000	74 000	3 100	2 040	8,8	30228-XL	T4FB140
	250	68	58	71,75	760 000	990 000	137 000	2 950	1 760	14,5	32228-XL	T4FD140
	300	62	53	67,75	690 000	730 000	93 000	2 750	2 000	20,3	30328-XL	–
	300	70	47	77	830 000	910 000	114 000	2 470	1 690	23,2	31328-X-XL	T7GB140
300	102	85	107,75	1 390 000	1 710 000	224 000	2 500	1 450	35,1	32328-XL	–	
150	210	38	30	38	285 000	495 000	53 000	3 200	2 040	3,9	32930	T2DC150
	210	30	23	32	217 000	345 000	33 500	3 250	2 040	3,1	T4DB150	–
	225	48	36	48	455 000	680 000	94 000	3 200	1 990	6,5	32030-X-XL	T4EC150
	225	59	46	59	550 000	890 000	124 000	3 150	1 910	8,1	33030-XL	T2EE150
	225	52	44	53	435 000	760 000	83 000	2 900	1 740	7,25	T2ED150	–
	270	45	38	49	550 000	630 000	82 000	2 900	1 880	10,9	30230-XL	T4GB150
	270	73	60	77	870 000	1 150 000	156 000	2 750	1 590	18,1	32230-XL	T4GD150
	320	65	55	72	800 000	1 030 000	113 000	2 270	1 630	25,2	30330-A	T2GB150
	320	75	50	82	930 000	1 040 000	128 000	2 300	1 540	27,8	31330-X-XL	T7GB150
	320	108	90	114	1 330 000	1 950 000	222 000	2 120	1 320	46,1	32330-A	–

medias ▶ <https://www.schaeffler.de/std/1F05>



Dimensions					Mounting dimensions										Calculation factors		
d	r ₁ , r ₂	r ₃ , r ₄	a	d ₁	d _a	d _b	D _a	D _a	D _b	C _a	C _b	r _a	r _b	e	Y	Y ₀	
	min.	min.	≈	≈	max.	min.	min.	max.	min.	min.	min.	max.	max.				
130	2	1,5	32	154,7	141	139	167	171	173	6	7	2	1,5	0,34	1,77	0,97	
	3	3	38	156,3	140	143	171	171	178	6	8	3	3	0,47	1,27	0,7	
	2,5	2	42	166,2	143	140	178	190	192	8	12	2,5	2	0,34	1,76	0,97	
	2,5	2	44	165,9	144	140	178	190	192	8	11	2,5	2	0,43	1,38	0,76	
	4	3	46	174,4	152	144	203	216	217	7	9,5	4	3	0,44	1,38	0,76	
	4	3	56	176,5	146	144	193	216	219	7	13,5	4	3	0,43	1,38	0,76	
	5	4	53	196,5	164	148	239	262	255	8	14,5	5	4	0,35	1,74	0,96	
	5	4	88	205	157	148	218	262	261	9	28	5	4	0,83	0,73	0,4	
	5	4	69	197,3	160	147	230	262	260	10	20,5	5	4	0,34	1,75	0,96	
140	2	1,5	34	164,8	150	149	177	181	184	6	7	2	1,5	0,36	1,67	0,92	
	3	3	41	167,2	150	153	180	183	189	6	8	3	3	0,5	1,19	0,66	
	2,5	2	46	175,8	152	150	186	200	202	7	12	2,5	2	0,36	1,67	0,92	
	2,5	2	46	175,6	153	150	187	200	202	8	11	2,5	2	0,46	1,31	0,72	
	4	3	43	175,6	154	159	193	202	206	9	9	4	3	0,32	1,88	1,04	
	4	3	48	188	163	154	219	236	234	9	9,5	4	3	0,43	1,38	0,76	
	4	3	60	191,5	159	154	210	236	238	8	13,5	4	3	0,43	1,38	0,76	
	5	4	52	204	176	158	255	282	273	8	14,5	5	4	0,28	2,18	1,2	
	5	4	94	220,5	169	158	235	282	280	9	30	5	4	0,83	0,73	0,4	
150	2,5	2	36	177,8	162	160	194	201	202	7	8	2,5	2	0,33	1,83	1,01	
	3	3	42	179	161	164	194	198	203	5	9	3	3	0,46	1,3	0,72	
	3	2,5	50	187,8	164	162	200	213	216	8	12	3	2,5	0,46	1,31	0,72	
	3	2,5	48	189,5	164	162	200	213	217	8	13	3	2,5	0,36	1,64	0,9	
	4	4	45	185,6	163	168	202	210	216	9	9	4	4	0,34	1,79	0,98	
	4	3	52	201,5	175	164	234	256	250	9	11	4	3	0,43	1,38	0,76	
	4	3	64	205,5	171	164	226	256	254	8	17	4	3	0,43	1,38	0,76	
	5	4	60	224	189	168	273	302	292	9	17	5	4	0,35	1,74	0,96	
	5	4	100	235,5	181	168	251	302	300	9	32	5	4	0,83	0,73	0,4	
5	4	79	230	184	167	264	302	299	12	24	5	4	0,35	1,74	0,96		





Tapered roller bearings

Single row to DIN/ISO

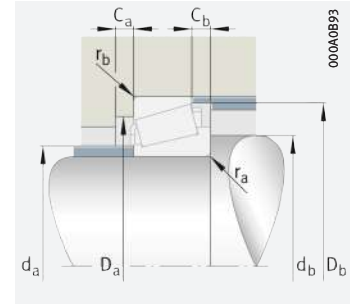
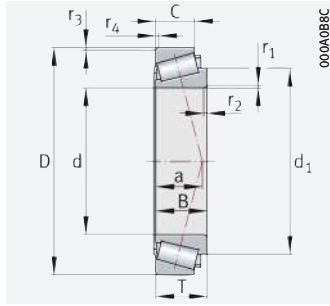

Mounting dimensions

d = 160 – 190 mm

Main dimensions					Basic load ratings		Fatigue limit load	Limiting speed	Speed rating	Mass	Designation	Interchange designation to ISO 10317 and ISO 355
d	D	B	C	T	dyn. C_r	stat. C_{0r}	C_{ur}	n_G	$n_{\theta r}$	m	▶ 573 1.12 ▶ 574 1.13 X-life ▶ 559	
					N	N	N	min^{-1}	min^{-1}	≈ kg		
160	220	38	30	38	295 000	530 000	56 000	3 000	1 900	4,13	32932	T2DC160
	220	30	23	32	226 000	370 000	38 000	3 050	1 910	3,3	T4DB160	–
	235	52	44	53	455 000	820 000	100 000	2 800	1 610	7,68	T2ED160	–
	240	51	38	51	500 000	740 000	102 000	3 000	1 850	7,8	32032-X-XL	T4EC160
	290	48	40	52	630 000	790 000	101 000	2 650	1 610	14,8	30232-XL	T4GB160
	290	80	67	84	1 030 000	1 380 000	184 000	2 550	1 430	23,1	32232-XL	T4GD160
	340	114	95	121	1 170 000	1 740 000	194 000	2 030	1 390	49,5	32332	–
	340	68	58	75	890 000	1 140 000	123 000	2 130	1 500	29,4	30332-A	T2GB160
170	230	38	30	38	295 000	560 000	59 000	2 850	1 790	4,36	32934	T3DC170
	230	30	23	32	228 000	390 000	39 500	2 950	1 790	3,47	T4DB170	–
	245	52	44	53	470 000	860 000	103 000	2 650	1 500	8,02	T2ED170	–
	260	57	43	57	600 000	880 000	119 000	2 750	1 690	10,5	32034-X-XL	T4EC170
	310	52	43	57	690 000	810 000	101 000	2 500	1 590	17	30234-XL	T4GB170
	310	86	71	91	1 160 000	1 560 000	204 000	2 350	1 310	28,8	32234-XL	T4GD170
	360	120	100	127	1 640 000	2 550 000	280 000	1 870	1 090	61,3	32334	–
	360	72	62	80	1 040 000	1 360 000	146 000	1 990	1 340	35,3	30334-A	T2GB170
180	240	30	23	32	230 000	400 000	44 500	2 800	1 710	3,65	T4DB180	–
	250	45	34	45	360 000	710 000	84 000	2 600	1 670	7,08	32936	T4DC180
	255	52	44	53	475 000	890 000	106 000	2 550	1 420	8,37	T2ED180	–
	280	64	48	64	740 000	1 100 000	144 000	2 550	1 510	14	32036-X-XL	T3FD180
	320	52	43	57	720 000	850 000	105 000	2 420	1 510	17,7	30236-XL	T4GB180
	320	86	71	91	1 190 000	1 640 000	213 000	2 270	1 240	30,1	32236-XL	T4GD180
	380	75	64	83	1 120 000	1 470 000	155 000	1 880	1 250	40,9	30336	–
	380	126	106	134	1 440 000	2 170 000	236 000	1 810	1 200	67,5	32336	–
190	260	45	34	45	370 000	750 000	89 000	2 490	1 560	6,87	32938	T4DC190
	260	34	27	37	300 000	520 000	60 000	2 600	1 630	5,32	T4DB190	–
	270	55	46	56	530 000	1 000 000	118 000	2 400	1 310	9,98	T2ED190	–
	290	64	48	64	740 000	1 120 000	147 000	2 460	1 440	14,6	32038-X-XL	T4FD190
	340	55	46	60	800 000	930 000	113 000	2 270	1 390	21,4	30238-XL	T4GB190
	340	92	75	97	1 340 000	1 820 000	231 000	2 120	1 150	35,9	32238-XL	T4GD190
	400	78	65	86	1 210 000	1 600 000	165 000	1 800	1 180	46,7	30338	–
	400	132	109	140	1 960 000	2 950 000	315 000	1 680	970	83,2	32338	–

medias ▶ <https://www.schaeffler.de/std/1F06>



Dimensions					Mounting dimensions									Calculation factors		
d	r ₁ , r ₂	r ₃ , r ₄	a	d ₁	d _a	d _b	D _a	D _a	D _b	C _a	C _b	r _a	r _b	e	Y	Y ₀
	min.	min.	≈	≈	max.	min.	min.	max.	min.	min.	min.	max.	max.			
160	2,5	2	38	188	173	170	204	210	212	7	8	2,5	2	0,35	1,73	0,95
	3	3	45	189,3	171	174	204	206	213	7	9	3	3	0,49	1,23	0,68
	4	4	47	195,8	173	178	211	220	226	9	9	4	4	0,35	1,71	0,94
	3	2,5	53	200,4	175	172	213	228	231	8	13	3	2,5	0,46	1,31	0,72
	4	3	56	220,5	189	174	252	276	269	9	12	4	3	0,43	1,38	0,76
	4	3	69	221	183	174	242	276	274	10	17	4	3	0,43	1,38	0,76
	5	4	86	245	190	177	280	321	320	12	26	5	4	0,38	1,58	0,87
	5	4	63	237	201	178	290	322	310	9	17	5	4	0,35	1,74	0,96
170	2,5	2	42	199	183	180	213	220	222	7	8	2,5	2	0,38	1,57	0,86
	3	3	45	199	182	185	214	216	223	6	9	3	3	0,46	1,3	0,72
	5	4	46	205,4	183	188	223	230	236	9	9	5	4	0,33	1,84	1,01
	3	2,5	57	214,5	187	182	230	248	249	10	14	3	2,5	0,44	1,35	0,74
	5	4	60	232	203	188	269	292	288	8	14	5	4	0,43	1,38	0,76
	5	4	74	237	196	188	259	292	294	10	20	5	4	0,43	1,38	0,76
	5	4	90	256	208	187	295	341	335	12	27	5	4	0,36	1,67	0,92
	5	4	67	252	213	188	307	342	329	9	18	5	4	0,35	1,74	0,96
180	3	3	48	209,4	192	195	224	228	233	5	9	3	3	0,48	1,24	0,68
	2,5	2	54	217	193	190	225	240	241	8	11	2,5	2	0,48	1,25	0,69
	5	4	49	215,6	193	198	232	239	246	9	9	5	4	0,34	1,77	0,97
	3	2,5	60	228	199	192	247	268	267	10	16	3	2,5	0,42	1,42	0,78
	5	4	62	241	211	198	278	302	297	9	14	5	4	0,45	1,33	0,73
	5	4	77	246,5	204	198	267	302	303	10	20	5	4	0,45	1,33	0,73
	5	4	69	267	230	197	327	359	350	10	19	5	4	0,35	1,74	0,96
	5	4	93	274	215	197	310	361	355	14	28	5	4	0,38	1,58	0,87
190	2,5	2	55	226	204	200	235	249	251	8	11	2,5	2	0,48	1,26	0,69
	3	3	50	223,5	204	207	241	246	251	7	10	3	3	0,45	1,33	0,73
	5	4	50	228,2	205	210	247	254	260	9	10	5	4	0,33	1,84	1,01
	3	2,5	63	239	209	202	257	278	279	10	16	3	2,5	0,44	1,36	0,75
	5	4	64	255,5	224	207	298	322	318	9	14	5	4	0,43	1,38	0,76
	5	4	81	261	216	207	286	322	323	10	22	5	4	0,43	1,38	0,76
	6	5	72	278,9	240	210	341	378	364	10	21	6	5	0,35	1,74	0,96
	6	5	97	281	230	210	330	378	373	14	31	6	5	0,35	1,73	0,95



Tapered roller bearings

Single row to DIN/ISO

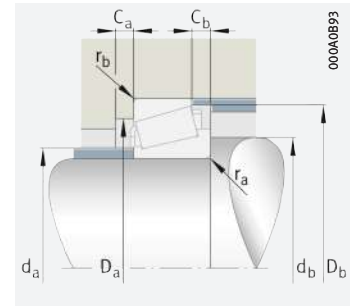
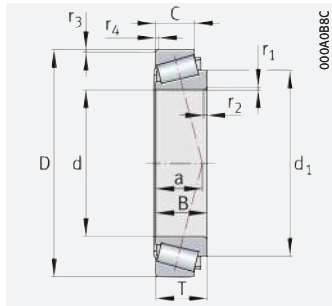

Mounting dimensions

d = 200 – 260 mm

Main dimensions					Basic load ratings		Fatigue limit load	Limiting speed	Speed rating	Mass	Designation	Interchange designation to ISO 10317 and ISO 355
d	D	B	C	T	dyn. C_r	stat. C_{0r}	C_{ur}	n_G	$n_{\theta r}$	m	▶ 573 1.12 ▶ 574 1.13 X-life ▶ 559	
					N	N	N	min^{-1}	min^{-1}	≈ kg		
200	270	34	27	37	310 000	550 000	63 000	2 460	1 530	5,55	T4DB200	–
	280	51	39	51	495 000	930 000	107 000	2 320	1 410	10,2	32940-A	T3EC200
	280	55	46	56	540 000	1 040 000	120 000	2 300	1 240	10,4	T2ED200	–
	310	70	53	70	900 000	1 380 000	176 000	2 290	1 280	18,7	32040-X-XL	T4FD200
	360	58	48	64	900 000	1 060 000	127 000	2 140	1 290	25,3	30240-XL	T4GB200
	360	98	82	104	1 570 000	2 080 000	255 000	2 030	1 080	42,8	32240-XL	T3GD200
	420	80	67	89	1 300 000	1 720 000	174 000	1 700	1 100	52,7	30340	–
	420	138	115	146	2 550 000	3 400 000	405 000	1 740	870	94	32340-XL	–
220	290	34	27	37	320 000	590 000	66 000	2 270	1 370	6	T4DB220	–
	300	51	39	51	495 000	980 000	110 000	2 150	1 280	10,1	32944	T3EC220
	300	55	46	56	570 000	1 140 000	130 000	2 140	1 100	11,3	T2ED220	–
	340	76	57	76	1 060 000	1 640 000	204 000	2 080	1 130	24,1	32044-X-XL	T4FD220
	400	65	54	72	1 120 000	1 330 000	150 000	1 930	1 130	34,5	30244-XL	–
	400	108	90	114	1 820 000	2 550 000	305 000	1 800	920	59,2	32244-XL	–
	460	88	73	97	1 440 000	1 880 000	185 000	1 560	1 030	68	30344	–
	460	145	122	154	2 400 000	3 650 000	370 000	1 470	820	115	32344	–
240	320	51	39	51	510 000	1 050 000	116 000	2 000	1 160	11	32948	T4EC240
	320	56	46	57	590 000	1 250 000	138 000	2 000	1 000	12,3	T2EE240	–
	360	76	57	76	1 060 000	1 680 000	207 000	1 950	1 060	25,8	32048-X-XL	T4FD240
	440	72	60	79	1 030 000	1 260 000	141 000	1 800	1 130	47,5	30248-XL	–
	440	120	100	127	2 190 000	3 100 000	365 000	1 630	810	80,5	32248-XL	–
	500	95	80	105	1 780 000	2 410 000	233 000	1 430	870	88,6	30348	–
	500	155	132	165	3 300 000	4 300 000	480 000	1 480	720	148	32348-XL	–
260	340	39	30	42	415 000	770 000	76 000	1 930	1 130	8,91	T4DB260	–
	360	63,5	48	63,5	890 000	1 500 000	181 000	1 960	1 000	18,6	32952-XL	T3EC260
	400	87	65	87	1 360 000	2 140 000	255 000	1 760	910	41,1	32052-X-XL	T4FC260
	480	80	67	89	1 730 000	2 090 000	224 000	1 580	860	63,2	30252-XL	–
	480	130	106	137	2 650 000	3 800 000	430 000	1 480	690	104	32252-XL	–
	540	102	85	113	1 940 000	2 600 000	247 000	1 320	820	105	30352	–
	540	165	136	176	3 150 000	4 900 000	475 000	1 240	650	181	32352	–

medias ▶ <https://www.schaeffler.de/std/1F07>



Dimensions					Mounting dimensions										Calculation factors		
d	r ₁ , r ₂	r ₃ , r ₄	a	d ₁	d _a	d _b	D _a	D _a	D _b	C _a	C _b	r _a	r _b	e	Y	Y ₀	
	min.	min.	≈	≈	max.	min.	min.	max.	min.	min.	min.	max.	max.				
200	3	3	54	234	214	218	251	254	262	7	10	3	3	0,47	1,27	0,7	
	3	2,5	54	239	216	212	257	268	271	9	12	3	2,5	0,39	1,52	0,84	
	5	4	53	238,3	214	220	256	264	271	9	10	5	4	0,34	1,77	0,97	
	3	2,5	67	253	221	212	273	298	297	11	17	3	2,5	0,43	1,39	0,77	
	5	4	69	270	237	217	315	342	336	9	16	5	4	0,43	1,38	0,76	
	5	4	83	269,5	226	217	302	342	340	11	22	5	4	0,41	1,48	0,81	
	6	5	76	288	250	250	360	397	385	10	22	6	5	0,35	1,74	0,96	
	6	5	104	302	240	258	344	397	392	17	31	6	5	0,36	1,67	0,92	
220	3	3	60	254,1	233	238	270	276	282	7	10	3	3	0,51	1,17	0,64	
	3	2,5	59	260	234	232	275	288	290	9	12	3	2,5	0,43	1,41	0,78	
	5	4	53	258,5	235	240	277	284	290	9	10	5	4	0,32	1,87	1,03	
	4	3	73	278,5	243	234	300	326	326	12	19	4	3	0,43	1,39	0,77	
	5	4	75	296	255	237	348	382	371	10	18	5	4	0,42	1,43	0,79	
	5	4	95	305	258	237	336	382	380	12	24	5	4	0,43	1,38	0,76	
	6	5	82	321	274	240	392	437	418	10	24	6	5	0,35	1,74	0,96	
	6	5	107	318,5	260	250	380	437	430	16	32	6	5	0,35	1,74	0,96	
240	3	2,5	65	281	254	252	294	308	311	9	12	3	2,5	0,46	1,31	0,72	
	6	4	58	278,8	254	260	296	304	311	9	11	6	4	0,34	1,74	0,96	
	4	3	79	298,5	261	254	318	346	346	12	19	4	3	0,46	1,31	0,72	
	5	4	76	322,5	285	257	383	420	410	10	19	5	4	0,36	1,68	0,92	
	5	4	105	334,5	286	257	372	422	415	14	27	5	4	0,43	1,38	0,76	
	6	5	90	347,5	296	260	425	476	454	12	25	6	5	0,35	1,74	0,96	
	6	5	115	351	285	260	411	476	465	16	32	6	5	0,35	1,74	0,96	
	260	3	3	68	297,5	274	279	318	326	330	8	12	3	3	0,49	1,23	0,67
3		2,5	70	307,5	279	272	328	348	347	11	15,5	3	2,5	0,41	1,48	0,81	
5		4	86	327,5	287	278	352	382	383	14	22	5	4	0,43	1,38	0,76	
6		5	89	353,5	310	280	419	457	447	10	22	6	5	0,4	1,48	0,81	
6		5	113	366	306	280	401	457	455	14	31	6	5	0,43	1,39	0,77	
7,5		6	96	377	320	286	456	508	490	12	28	7,5	6	0,35	1,73	0,95	
7,5		6	124	381,8	310	286	450	513	500	16	40	7,5	6	0,35	1,74	0,96	





Tapered roller bearings

Single row to DIN/ISO

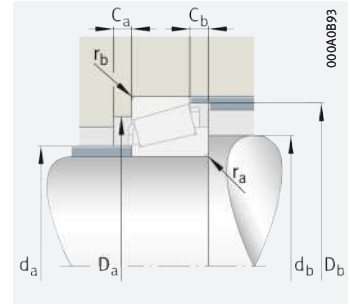
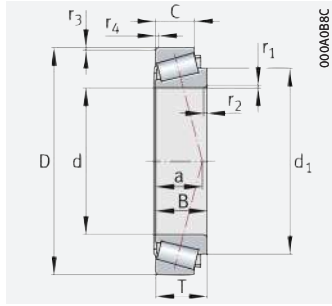

Mounting dimensions

d = 280 – 360 mm

Main dimensions					Basic load ratings		Fatigue limit load	Limiting speed	Speed rating	Mass	Designation	Interchange designation to ISO 10317 and ISO 355
d	D	B	C	T	dyn. C_r	stat. C_{0r}	C_{ur}	n_G	$n_{\theta r}$	m	▶ 573 1.12 ▶ 574 1.13 X-life ▶ 559	
					N	N	N	min^{-1}	min^{-1}	≈ kg		
280	380	63,5	48	63,5	880 000	1 520 000	184 000	1 840	940	19,8	32956-XL	T4EC280
	420	87	65	87	1 420 000	2 300 000	270 000	1 670	840	40,8	32056-X-XL	T4FC280
	500	80	67	89	1 740 000	2 130 000	229 000	1 520	830	66,5	30256-XL	–
	500	130	106	137	2 700 000	3 950 000	445 000	1 410	650	112	32256-XL	–
	580	108	90	119	2 300 000	3 150 000	285 000	1 230	710	133	30356	–
	580	175	145	187	3 600 000	5 700 000	530 000	1 150	570	220	32356	–
300	420	76	57	76	1 170 000	2 040 000	238 000	1 660	810	31,3	32960-XL	T3FD300
	460	100	74	100	1 780 000	2 850 000	330 000	1 520	750	58,1	32060-X-XL	T4GD300
	540	85	71	96	2 020 000	2 440 000	255 000	1 410	750	83,7	30260-XL	–
	540	140	115	149	3 150 000	4 550 000	500 000	1 310	590	139	32260-XL	–
320	440	76	57	76	1 260 000	2 280 000	260 000	1 580	730	33,5	32964-XL	T3FD320
	480	100	74	100	1 850 000	3 050 000	350 000	1 440	690	60,8	32064-X-XL	T4GD320
	580	92	75	104	2 310 000	3 000 000	305 000	1 290	650	107	30264-XL	–
	580	150	125	159	3 550 000	5 200 000	560 000	1 210	530	170	32264-XL	–
340	460	76	57	76	1 270 000	2 370 000	300 000	1 500	690	35	32968-XL	T4FD340
360	480	76	57	76	1 260 000	2 370 000	265 000	1 430	660	36,4	32972-XL	T4FD360

medias ▶ <https://www.schaeffler.de/std/1F08>



Dimensions					Mounting dimensions										Calculation factors		
d	r ₁ , r ₂	r ₃ , r ₄	a	d ₁	d _a	d _b	D _a	D _a	D _b	C _a	C _b	r _a	r _b	e	Y	Y ₀	
	min.	min.	≈	≈	max.	min.	min.	max.	min.	min.	min.	max.	max.				
280	3	2,5	75	328	298	292	348	368	368	11	15,5	3	2,5	0,43	1,39	0,76	
	5	4	91	347	305	298	370	402	402	14	22	5	4	0,46	1,31	0,72	
	6	5	97	369,5	330	300	433	477	465	12	22	6	5	0,45	1,33	0,73	
	6	5	118	384,5	322	300	418	477	475	14	31	6	5	0,45	1,34	0,73	
	7,5	6	101	401,7	345	357	492	548	525	15	29	7,5	6	0,35	1,74	0,96	
	7,5	6	132	411,6	335	306	480	552	540	16	41	7,5	6	0,35	1,74	0,96	
300	4	3	80	359	324	314	383	406	405	12	19	4	3	0,39	1,52	0,84	
	5	4	98	376	329	318	404	442	439	15	26	5	4	0,43	1,38	0,76	
	6	5	103	391,5	340	352	468	517	500	15	25	6	5	0,43	1,38	0,76	
	6	5	127	412,5	346	320	453	517	510	16	34	6	5	0,43	1,38	0,76	
320	4	3	86	379	343	334	402	426	426	13	19	4	3	0,42	1,44	0,79	
	5	4	104	398,5	350	338	424	462	461	15	26	5	4	0,46	1,31	0,72	
	6	5	112	432,5	380	340	501	556	536	12	29	6	5	0,43	1,38	0,76	
	6	5	136	443	372	340	486	556	555	16	34	6	5	0,43	1,38	0,76	
340	4	3	91	399	361	354	421	446	446	12	19	4	3	0,44	1,37	0,75	
360	4	3	97	419,5	380	374	439	466	466	14	19	4	3	0,46	1,31	0,72	



Tapered roller bearings

Single row to ANSI/ABMA

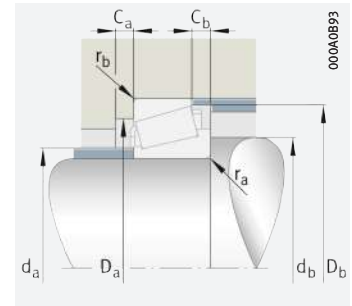
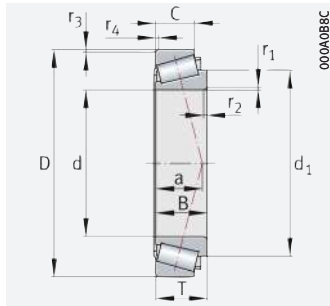

Mounting dimensions

d = 15,875 – 34,925 mm

Main dimensions					Basic load ratings		Fatigue limit load	Limiting speed	Mass	Designation
d	D	B	C	T	dyn. C_r	stat. C_{0r}	C_{ur}	n_G	m	▶ 573 1.12 ▶ 574 1.13 X-life ▶ 559
					N	N	N	min^{-1}	≈ kg	
15,875	42,863	14,287	9,525	14,288	17 900	18 000	1 890	18 800	0,104	K11590-11520
17,462	39,878	14,605	10,668	13,843	21 200	20 800	2 190	20 100	0,08	KLM11749-LM11710
19,05	45,237	16,637	12,065	15,494	28 000	28 000	3 050	17 800	0,131	KLM11949-LM11910
21,43	50,005	18,288	13,97	17,526	37 500	39 000	4 400	15 800	0,169	KM12649-M12610
21,986	45,237	16,637	12,065	15,494	28 500	32 000	3 550	16 900	0,118	KLM12749-LM12710
	45,974	16,637	12,065	15,494	28 500	32 000	3 550	16 900	0,122	KLM12749-LM12711
22,606	47	15,5	12	15,5	23 700	27 000	2 850	16 300	0,129	KLM72849-LM72810
25,4	50,292	14,732	10,668	14,224	26 000	29 500	3 150	15 200	0,128	KL44643-L44610
	56,896	19,837	15,875	19,368	43 000	46 500	5 300	14 200	0,243	K1780-1729
26,988	50,292	14,732	10,668	14,224	26 000	29 500	3 150	15 200	0,128	KL44649-L44610
	63,5	20,638	15,875	20,638	47 500	55 000	6 300	12 100	0,324	K15106-15250-X
28,575	57,15	19,355	15,875	19,845	48 000	55 000	6 400	13 100	0,233	K1985-1922
	57,15	19,355	15,875	19,845	48 000	55 000	6 400	13 100	0,267	K1988-1922
	59,131	16,764	11,811	15,875	34 000	40 000	4 500	12 800	0,207	KLM67043-LM67010
	72,626	24,257	17,462	24,608	56 000	53 000	6 000	10 900	0,492	K41125-41286
30,162	64,292	21,433	16,67	21,433	52 000	67 000	8 000	11 500	0,376	KM86649-M86610
31,75	59,131	16,764	11,811	15,875	34 000	40 000	4 500	12 800	0,187	KLM67047-LM67010
	59,131	16,764	11,811	15,875	34 000	40 000	4 500	12 800	0,203	KLM67048-LM67010
	59,131	16,764	11,811	15,875	34 000	40 000	4 500	12 800	0,19	KLM67049-A-LM67010
	61,986	16,764	11,811	15,875	34 000	40 000	4 500	12 800	0,212	KLM67048-LM67014
	73,025	27,782	23,02	29,37	72 000	97 000	12 100	9 900	0,641	KHM88542-HM88510
	76,2	28,575	23,02	29,37	79 000	107 000	13 400	9 400	0,705	KHM89440-HM89411
	76,2	28,575	23,02	29,37	79 000	107 000	13 400	9 400	0,757	KHM89443-HM89410
33,338	68,262	22,225	17,462	22,225	56 000	72 000	8 700	10 700	0,38	KM88048-M88010
	73,025	27,783	23,02	29,37	72 000	97 000	12 100	9 900	0,601	KHM88547-HM88510
	76,2	28,575	23,02	29,37	79 000	107 000	13 400	9 400	0,757	KHM89443-HM89410
34,925	65,088	18,288	13,97	18,034	46 500	56 000	6 400	11 500	0,261	KLM48548-A-LM48510
	65,088	18,288	13,97	18,034	46 500	56 000	6 400	11 500	0,252	KLM48548-LM48510
	65,088	18,288	13,97	18,034	46 500	56 000	6 400	11 500	0,278	KLM48549-X-LM48510
	72,233	25,4	19,842	25,4	68 000	91 000	11 300	10 000	0,5	KHM88649-HM88610
	73,025	24,608	19,05	23,812	78 000	78 000	12 400	11 400	0,462	K25877-25821-XL
	76,2	28,575	23,812	29,37	77 000	91 000	11 100	9 700	0,636	K31594-31520
	76,2	28,575	23,02	29,37	79 000	107 000	13 400	9 400	0,664	KHM89446-HM89410
	79,375	29,771	23,812	29,37	90 000	110 000	13 500	9 400	0,785	K3478-3420

medias ▶ <https://www.schaeffler.de/std/1F09>



Dimensions					Mounting dimensions								Calculation factors		
d	r ₁ , r ₂	r ₃ , r ₄	a	d ₁	d _a	d _b	D _a	D _b	C _a	C _b	r _a	r _b	e	Y	Y ₀
	min.	min.	≈	≈	max.	min.	min.	min.	min.	min.	max.	max.			
15,875	1,5	1,5	13	32,1	22,5	24,5	34,5	39,5	2	4,5	1,5	1,5	0,7	0,85	0,47
17,462	1,3	1,3	9	29,6	21,5	23	34	37	3	3	1,3	1,3	0,29	2,1	1,15
19,05	1,3	1,3	10	31,8	23,5	25	39,5	41,5	3,5	4,5	1,3	1,3	0,3	2	1,1
21,43	1,3	1,3	11	34,5	25,5	27,5	44	46	4	3,5	1,3	1,3	0,28	2,16	1,19
21,986	1,3	1,3	10	34,8	26	27,5	39,5	42	3	3	1,3	1,3	0,31	1,96	1,08
	1,3	1,3	10	34,8	26	27,5	40	42,5	3	3	1,3	1,3	0,31	1,96	1,08
22,606	1,5	1	13	36,1	28	30	40,5	44	2	3	1,5	1	0,47	1,27	0,7
25,4	1,3	1,3	11	39,5	30	32	44,5	47	3	3,5	1,3	1,3	0,37	1,6	0,88
	0,8	1,3	13	39,9	30	30,5	49	51	2	3	0,8	1,3	0,31	1,95	1,07
26,988	3,6	1,3	11	40,1	31	37,5	44,5	47	2,5	3,5	3,6	1,3	0,37	1,6	0,88
	0,8	1,5	15	46,8	32,5	33,5	55	59	3	3,5	0,8	1,5	0,35	1,71	0,94
28,575	0,8	1,5	14	43	33,5	34	51	53,5	3	3,5	0,8	1,5	0,33	1,82	1
	3,6	1,5	14	43	33,5	39,5	51	53,5	3	4	3,6	1,5	0,33	1,82	1
	4,75	1,3	13	45,7	34	40,5	52	56	3	4	4,75	1,3	0,41	1,46	0,8
	4,8	1,5	21	50,8	36,5	48	61	68	4	6,5	4,8	1,5	0,6	0,99	0,55
30,162	1,5	1,5	18	50,7	38	44	54	60	3	4,5	1,5	1,5	0,55	1,1	0,6
31,75	2,3	1,3	13	45,7	36,5	42,5	52	56	3	4	2,3	1,3	0,41	1,46	0,8
	3,6	1,3	13	45,8	36	42,5	52	56	3,5	4,5	3,6	1,3	0,41	1,46	0,8
	0,8	1,3	13	45,8	36	37	52	56	3	4	0,8	1,3	0,41	1,46	0,8
	3,6	1,3	13	45,8	36	42,5	52	56	3,5	4,5	3,6	1,3	0,41	1,46	0,8
	1,3	3,3	24	58	42,6	45,5	59	70	4	6	1,3	3,3	0,55	1,1	0,6
	0,8	0,8	24	60,1	44,5	45,5	65	73	3	6	0,8	0,8	0,55	1,1	0,6
33,338	0,8	1,5	20	53,3	41	42,5	58	65	3	4	0,8	1,5	0,55	1,1	0,6
	0,8	3,3	24	56,8	42,6	45,5	59	70	4	6	0,8	3,3	0,55	1,1	0,6
	0,8	3,3	24	60,5	44,5	46,5	62	73	3	5,5	0,8	3,3	0,55	1,1	0,6
34,925	0,8	1,3	14	49,9	42,2	40,5	58	61	4	4	0,8	1,3	0,38	1,59	0,88
	3,6	1,3	14	49,7	41,5	48	58	61	3	4	3,6	1,3	0,38	1,59	0,88
	2,3	1,3	14	49,7	40	42	58	61	3	4	2,3	1,3	0,38	1,59	0,88
	2,3	2,3	21	56,8	42,5	48,5	60	69	3	5	2,3	2,3	0,55	1,1	0,6
	1,5	0,8	16	53,9	43	46	62	67	5	4	1,5	0,8	0,29	2,07	1,14
	1,5	3,3	22	57,2	43,5	46	64	72	2	5	1,5	3,3	0,4	1,49	0,82
	3,6	3,3	24	60,5	44,6	53	62	73	3	6	3,6	3,3	0,55	1,1	0,6
	3,6	3,3	21	57,5	43,5	50	67	74	2	5	3,6	3,3	0,37	1,64	0,9



Tapered roller bearings

Single row to ANSI/ABMA

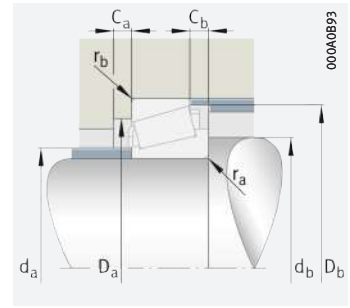
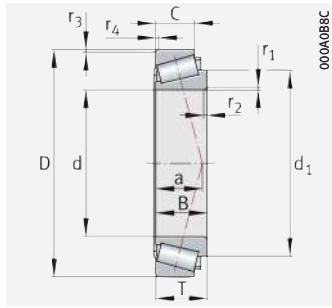

Mounting dimensions

d = 34,988 – 41,275 mm

Main dimensions					Basic load ratings		Fatigue limit load	Limiting speed	Mass	Designation
d	D	B	C	T	dyn. C_r	stat. C_{0r}	C_{ur}	n_G	m	▶ 573 1.12 ▶ 574 1.13 X-life ▶ 559
					N	N	N	min^{-1}	≈ kg	
34,988	59,131	16,764	11,938	15,875	34 000	44 500	5 000	12 400	0,171	KL68149-L68110
	59,974	16,764	11,938	15,875	34 000	44 500	5 000	12 400	0,179	KL68149-L68111
	61,973	17	15	18	38 000	49 000	5 700	11 800	0,215	KLM78349-A-LM78310-C
	61,973	17	13,6	16,7	38 000	49 000	5 700	11 800	0,2	KLM78349-LM78310-A
35,717	72,233	25,4	19,842	25,4	68 000	91 000	11 300	10 000	0,54	KHM88648-HM88610
36,512	76,2	28,575	23,02	29,37	79 000	107 000	13 400	9 400	0,65	KHM89448-HM89410
	76,2	28,575	23,02	29,37	79 000	107 000	13 400	9 400	0,717	KHM89449-HM89410
	76,2	28,575	23,02	29,37	79 000	107 000	13 400	9 400	0,647	KHM89449-HM89411
	79,375	28,829	22,664	29,37	92 000	111 000	13 600	9 200	0,679	KHM89249-HM89210
38	63	17	13,5	17	39 500	53 000	6 100	11 400	0,204	KJL69349-JL69310
38,1	65,088	18,288	13,97	18,034	45 000	60 000	6 900	11 200	0,227	KLM29748-LM29710
	65,088	18,288	13,97	18,034	45 000	60 000	6 900	11 200	0,26	KLM29749-LM29710
	65,088	18,288	15,748	19,812	45 000	60 000	6 900	11 200	0,275	KLM29749-LM29711
	79,375	29,771	23,812	29,37	90 000	110 000	13 500	9 400	0,677	K3490-3420
	82,55	28,575	23,02	29,37	89 000	122 000	15 200	8 700	0,874	KHM801346-HM801310
	90,488	40,386	33,338	39,688	142 000	185 000	23 200	8 000	1,33	K4375-4335
39,688	79,974	30,391	23,812	29,37	94 000	109 000	13 400	9 200	0,731	K3382-3325
	79,974	30,391	23,812	29,37	94 000	109 000	13 400	9 200	0,534	K3386-3325
	80,167	30,391	23,812	29,37	94 000	109 000	13 400	9 200	0,66	K3382-3320
	80,167	30,391	23,812	29,37	94 000	109 000	13 400	9 200	0,537	K3386-3320
40,483	82,55	28,575	23,02	29,37	89 000	122 000	15 200	8 700	0,724	KHM801349-HM801310
40,987	67,975	18	13,5	17,5	46 000	63 000	7 300	10 700	0,255	KLM300849-LM300811
	78	18	13,5	17,5	46 000	63 000	7 300	10 700	0,392	KLM300849-LM300816
41,275	73,431	19,812	14,732	19,558	55 000	68 000	8 100	10 000	0,334	KLM501349-LM501310
	73,431	19,812	16,604	21,43	55 000	68 000	8 100	10 000	0,366	KLM501349-LM501314
	80	22,403	21	24,176	68 000	74 000	8 700	9 400	0,498	K336-332-A
	82,55	25,654	20,193	26,543	83 000	111 000	13 800	8 700	0,647	KM802048-M802011
	87,313	30,886	23,812	30,163	97 000	121 000	14 900	8 500	0,857	K3585-3525
	88,5	29,083	22,225	26,988	89 000	98 000	11 700	8 900	0,79	K419-414
	88,9	29,37	23,02	30,162	93 000	123 000	15 400	8 000	0,9	KHM803146-HM803110
	90	22,225	15,875	20	72 000	84 000	9 900	8 400	0,648	K365-A-362
	93,662	31,75	26,195	31,75	110 000	142 000	17 600	7 900	1,12	K46162-46368
	95,25	29,37	23,02	30,162	111 000	151 000	18 900	7 500	1,19	KHM804840-HM804810

medias ▶ <https://www.schaeffler.de/std/1FOA>



Dimensions					Mounting dimensions								Calculation factors		
d	r ₁ , r ₂	r ₃ , r ₄	a	d ₁	d _a	d _b	D _a	D _b	C _a	C _b	r _a	r _b	e	Y	Y ₀
	min.	min.	≈	≈	max.	min.	min.	min.	min.	min.	max.	max.			
34,988	3,6	1,3	13	48,8	39	45,5	53	56	3	4	3,6	1,3	0,42	1,44	0,79
	3,6	1,3	13	48,8	39	45,5	53	56	3	4	3,6	1,3	0,42	1,44	0,79
	1,5	1,5	16	49,7	39,5	42	56	59	3	3	1,5	1,5	0,44	1,35	0,74
	3,6	1,5	14	49,7	40	46	54	59	3	3	3,6	1,5	0,44	1,35	0,74
35,717	3,5	2,3	21	56,8	43	52	60	69	4	5,5	3,5	2,3	0,55	1,1	0,6
36,512	0,8	3,3	24	60,5	44,5	48,5	62	73	3	5,5	0,8	3,3	0,55	1,1	0,6
	3,6	3,3	24	60,5	44,5	54	62	73	3	5,5	3,6	3,3	0,55	1,1	0,6
	3,6	0,8	24	60,1	44,5	54	65	73	3	5	3,6	0,8	0,55	1,1	0,6
	3,6	3,3	23	59,3	44	55	66	75	3	6,7	3,6	3,3	0,55	1,1	0,6
38	3,6	1,3	15	51,8	42,5	49	56	60	3	4	3,6	1,3	0,42	1,44	0,79
38,1	3,6	1,3	13	53	42,5	49	59	62	2	4	3,6	1,3	0,33	1,8	0,99
	2,3	1,3	13	53	42,5	46	59	62	2	4	2,3	1,3	0,33	1,8	0,99
	2,3	1,3	15	53	42,5	46	58	62	2	4	2,3	1,3	0,33	1,8	0,99
	3,6	3,3	21	57,5	45,5	52	67	74	2	5	3,6	3,3	0,37	1,64	0,9
	0,8	3,3	24	64,3	49,1	51	68	78	5	6	0,8	3,3	0,55	1,1	0,6
	1,5	3,3	25	66,1	51	53	77	85	3,5	6,3	1,5	3,3	0,28	2,11	1,16
39,688	3,6	3,3	19	59,5	45,5	52	70	75	2	6	3,6	3,3	0,27	2,2	1,21
	0,8	3,3	19	59,5	45,5	46,5	70	75	2	6	0,8	3,3	0,27	2,2	1,21
	3,6	3,3	19	59,5	45,5	52	70	75	2	6	3,6	3,3	0,27	2,2	1,21
	0,8	3,3	19	59,5	45,5	46,5	70	75	2	6	0,8	3,3	0,27	2,2	1,21
40,483	3,6	3,3	24	65,6	49	58	68	78	3	6	3,6	3,3	0,55	1,1	0,6
40,987	3,6	1,5	14	55,8	45	52	61	65	3	4	3,6	1,5	0,35	1,72	0,95
	3,6	0,3	14	55,8	45	52	61	65	5	4	3,6	0,3	0,35	1,72	0,95
41,275	3,6	0,8	16	57,2	46,5	53	67	70	4	4,5	3,6	0,8	0,4	1,5	0,83
	3,6	0,8	18	57,2	46,5	53	66	70	1,5	4,5	3,6	0,8	0,4	1,5	0,83
	0,8	2,3	18	59,1	46	47	71	75	2	6	0,8	2,3	0,27	2,21	1,21
	3,6	3,3	23	64,2	51	57	70	79	3	5,5	3,6	3,3	0,55	1,1	0,6
	1,5	3,3	20	64,5	48	50	75	81	3,5	6	1,5	3,3	0,31	1,96	1,08
	3,6	1,5	17	60,4	47	54	77	80	5	6	3,6	1,5	0,26	2,27	1,25
	3,6	3,3	26	69,5	52	57	70	84	4	7	3,6	3,3	0,55	1,1	0,6
	3,6	2	16	68,1	48,5	55	81	84	5	5,5	3,6	2	0,32	1,88	1,03
	0,8	3,3	24	69,1	51	52	79	87	3,5	5,5	0,8	3,3	0,4	1,49	0,82
	3,6	3,3	26	73,1	54	61	81	91	4,5	7	3,6	3,3	0,55	1,1	0,6





Tapered roller bearings

Single row to ANSI/ABMA

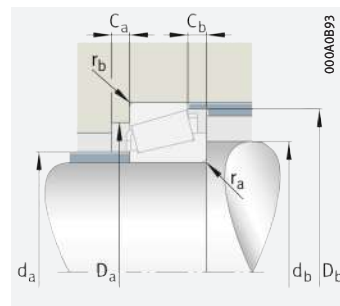
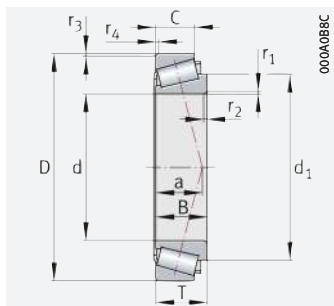

Mounting dimensions

d = 42,07 – 47,625 mm

Main dimensions					Basic load ratings		Fatigue limit load	Limiting speed	Mass	Designation
d	D	B	C	T	dyn. C_r	stat. C_{0r}	C_{ur}	n_G	m	▶ 573 1.12 ▶ 574 1.13 X-life ▶ 559
					N	N	N	min^{-1}	≈ kg	
42,07	90,488	40,386	33,338	39,688	142 000	185 000	23 200	8 000	1,29	K4395-4335
44,45	82,931	25,4	19,05	23,812	81 000	105 000	13 000	8 900	0,561	K25581-25520
	88,9	29,37	23,02	30,162	93 000	123 000	15 400	8 000	0,86	KHM803149-HM803110
	90,119	21,692	21,808	23	74 000	86 000	10 200	8 800	0,694	K355-X-352
	93,264	30,302	23,812	30,162	123 000	138 000	22 200	8 500	0,976	K3782-3720-XL
	93,662	31,75	25,4	31,75	109 000	130 000	15 800	8 000	1,02	K49175-49368
	95,25	28,575	22,225	27,783	131 000	145 000	23 400	8 300	1	AK33885-33822-XL
	95,25	29,37	23,02	30,162	111 000	151 000	18 900	7 500	1,13	KHM804842-HM804810
	95,25	29,37	23,02	30,162	111 000	151 000	18 900	7 500	1,16	KHM804843-HM804810
	95,25	28,575	22,225	30,958	99 000	120 000	14 400	7 500	1,01	KHM903249-HM903210
	101,6	31,75	25,4	31,75	108 000	132 000	16 100	7 200	1,27	K49576-49520
104,775	36,512	28,575	36,512	145 000	201 000	25 500	6 700	1,6	KHM807040-HM807010	
111,125	36,957	30,162	38,1	146 000	186 000	23 000	6 900	1,88	K535-532-A	
44,987	104,986	31,75	23,368	32,512	116 000	157 000	19 200	6 600	1,43	KHM905843-HM905810
45,242	73,431	19,812	15,748	19,558	57 000	79 000	9 500	9 700	0,316	KLM102949-LM102910
	77,788	19,842	15,08	19,842	55 000	69 000	8 200	9 300	0,369	KLM603049-LM603011
	77,788	19,842	16,667	21,43	55 000	69 000	8 200	9 300	0,38	KLM603049-LM603012
	80	19,842	15,08	19,842	55 000	69 000	8 200	9 300	0,399	KLM603049-LM603014
45,618	83,058	25,4	19,114	23,877	81 000	105 000	13 000	8 900	0,577	K25590-25522
45,987	74,975	18	14	18	48 500	67 000	7 900	9 600	0,3	KLM503349-A-LM503310
	74,975	18	14	18	48 500	67 000	7 900	9 600	0,304	KLM503349-LM503310
	90,975	32	26,5	32	117 000	146 000	18 100	7 900	0,958	KHM204049-HM204010
46,038	85	21,692	17,462	20,635	74 000	86 000	10 200	8 800	0,694	K359-S-354-X
47,625	88,9	22,225	16,513	20,637	72 000	84 000	9 900	8 400	0,559	K369-A-362-A
	88,9	22,225	16,513	20,637	72 000	84 000	9 900	8 400	0,556	K369-S-362-A
	95,25	29,37	23,02	30,162	111 000	151 000	18 900	7 500	1,09	KHM804846-HM804810
	96,838	21,946	15,875	21	76 000	95 000	11 200	7 500	0,725	K386-A-382-A
	112,713	28,575	20,638	30,163	102 000	133 000	16 100	6 300	1,5	KHM907639-HM907616

medias ▶ <https://www.schaeffler.de/std/1F0B>



Dimensions					Mounting dimensions								Calculation factors		
d	r ₁ , r ₂	r ₃ , r ₄	a	d ₁	d _a	d _b	D _a	D _b	C _a	C _b	r _a	r _b	e	Y	Y ₀
	min.	min.	≈	≈	max.	min.	min.	min.	min.	min.	max.	max.			
42,07	3,6	3,3	25	66,1	51	57	78	85	4	6	3,6	3,3	0,28	2,11	1,16
44,45	0,5	0,8	18	64,1	50	51	74	77	4,5	5,5	0,5	0,8	0,33	1,79	0,99
	3,6	3,3	26	69,1	53	62	74	85	4	7	3,6	3,3	0,55	1,1	0,6
	3,6	2,3	18	63,2	50	56	78	82	2	2,5	3,6	2,3	0,31	1,96	1,08
	3,6	3,3	22	72,2	52	58	82	88	3,5	7	3,6	3,3	0,34	1,77	0,97
	3,6	3,3	23	67,2	53	59	82	87	3	5,5	3,6	3,3	0,36	1,67	0,92
	0,8	0,8	20	73,4	53	53	86	90	5,5	6,5	0,8	0,8	0,33	1,82	1
	3,6	3,3	26	73,1	54	61	81	91	4,5	7	3,6	3,3	0,55	1,1	0,6
	3,6	3,3	26	73,1	57	63	81	91	4,5	7	3,6	3,3	0,55	1,1	0,6
	3,6	0,8	31	72	54	65	81	91	2	6,5	3,6	0,8	0,74	0,81	0,45
	0,8	3,3	25	76,5	54	55	88	96	4	6,5	0,8	3,3	0,4	1,5	0,82
	3,6	3,3	29	80,4	59	66	91	100	6	7,5	3,6	3,3	0,49	1,23	0,68
	3,6	3,3	26	78,1	54	60	95	100	2,5	8	3,6	3,3	0,3	2,02	1,11
44,987	2,5	2,5	34	82,2	60	68	86	100	3	7	2,5	2,5	0,78	0,77	0,42
45,242	3,6	0,8	15	60	50	56	68	70	3	4	3,6	0,8	0,31	1,97	1,08
	3,6	0,8	18	61,7	50	57	71	74	3	4,5	3,6	0,8	0,43	1,41	0,77
	3,6	0,8	19	61,7	50	57	70	74	2	4,5	3,6	0,8	0,43	1,41	0,77
	3,6	0,8	18	61,7	50	57	71	75	3	4,5	3,6	0,8	0,43	1,41	0,77
45,618	3,6	2	18	64,1	51	58	73	77	4,5	5,5	3,6	2	0,33	1,79	0,99
45,987	3,6	1,5	16	62	51	57	67	71	3,5	4	3,6	1,5	0,4	1,49	0,82
	2,3	1,5	16	61,9	51	55	67	71	4	3,5	2,3	1,5	0,4	1,49	0,82
	3,6	3,6	22	67,5	54	63	79	86	4	4	3,6	3,6	0,33	1,8	0,99
46,038	2,3	1,5	16	63,2	51	55	77	80	3	3	2,3	1,5	0,31	1,96	1,08
47,625	3,6	1,3	16	68,1	53	60	81	84	5	5,5	3,6	1,3	0,32	1,88	1,03
	2,3	1,3	16	68,1	53	60	81	84	5	5,5	2,3	1,3	0,32	1,88	1,03
	3,6	3,3	26	73,1	57	66	81	91	4,5	7	3,6	3,3	0,55	1,1	0,6
	0,8	0,8	19	76,6	55	56	89	92	5,5	5	0,8	0,8	0,35	1,69	0,93
	3,6	3,3	37	85,7	65,3	72	91	106	4	10	3,6	3,3	0,88	0,68	0,37





Tapered roller bearings

Single row to ANSI/ABMA

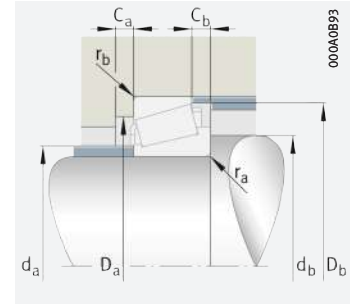
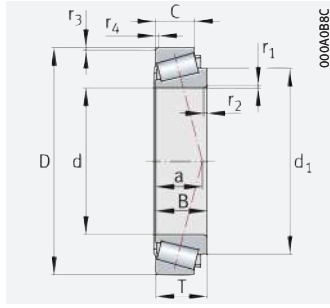

Mounting dimensions

d = 48,412 – 55 mm

Main dimensions					Basic load ratings		Fatigue limit load	Limiting speed	Mass	Designation
d	D	B	C	T	dyn. C _r	stat. C _{0r}	C _{ur}	n _G	m	
					N	N	N	min ⁻¹	≈ kg	
48,412	95,25	29,37	23,02	30,162	111 000	151 000	18 900	7 500	1,37	KHM804848-HM804810
	95,25	29,37	23,02	30,162	111 000	151 000	18 900	7 500	1,09	KHM804848-HM804811
	95,25	29,37	23,02	30,162	111 000	151 000	18 900	7 500	1,09	KHM804849-HM804810
49,212	104,775	36,512	28,575	36,512	145 000	201 000	25 500	6 700	1,5	KHM807044-HM807010
50	90	28	23	28	104 000	136 000	16 900	7 900	0,744	KJM205149-JM205110
50,8	82,55	22,225	16,51	21,59	69 000	94 000	11 500	8 700	0,428	KLM104949-LM104911
	82,931	22,225	16,51	21,59	69 000	94 000	11 500	8 700	0,432	KLM104949-LM104912
	88,9	22,225	16,513	20,637	72 000	84 000	9 900	8 400	0,516	K368-362-A
	88,9	22,225	16,513	20,637	72 000	84 000	9 900	8 400	0,555	K368-A-362-A
	93,264	30,302	23,812	30,162	104 000	137 000	17 000	7 700	0,89	K3780-3720
	95,25	28,575	22,225	27,783	107 000	138 000	17 200	7 500	0,861	K33889-33822
	104,775	30,958	23,812	30,162	126 000	162 000	20 100	6 800	1,25	K45284-45220
	104,775	40,157	33,338	39,688	159 000	226 000	28 500	6 700	1,67	K4580-4535
	104,775	36,512	28,575	36,512	145 000	201 000	25 500	6 700	1,64	KHM807046-HM807010
	104,775	36,512	28,575	36,512	145 000	201 000	25 500	6 700	1,49	KHM807046-HM807011
	107,95	36,957	28,575	36,512	146 000	186 000	23 000	6 900	1,69	K537-532-X
	111,125	28,575	20,638	30,163	106 000	140 000	16 900	6 300	1,4	KHM907643-HM907614
	123,825	32,791	25,4	36,512	135 000	150 000	17 900	6 000	2,18	K72200-72487
51,592	88,9	22,225	16,513	20,637	72 000	84 000	9 900	8 400	0,509	K368-S-362-A
	90	22,225	20	20	72 000	84 000	9 900	8 400	0,545	K368-S-363
53,975	88,9	19,05	13,492	19,05	69 000	78 000	12 100	8 800	0,434	KLM806649-LM806610-XL
	95,25	28,575	22,225	27,783	107 000	138 000	17 200	7 500	0,806	K33895-33822
	104,775	36,512	28,575	36,512	145 000	201 000	25 500	6 700	1,42	KHM807049-HM807010
	123,825	32,791	25,4	36,512	135 000	150 000	17 900	6 000	1,98	K72212-72487
54,488	104,775	36,512	28,575	36,512	145 000	201 000	25 000	6 700	1,41	KHM807048-HM807010
55	95	29	23,5	29	111 000	152 000	19 000	7 400	0,8	KJM207049-JM207010
	96,838	21,946	15,875	21	76 000	95 000	11 200	7 500	0,63	K385-X-382-A

medias ► <https://www.schaeffler.de/std/1FOC>



Dimensions					Mounting dimensions								Calculation factors		
d	r ₁ , r ₂	r ₃ , r ₄	a	d ₁	d _a	d _b	D _a	D _b	C _a	C _b	r _a	r _b	e	Y	Y ₀
	min.	min.	≈	≈	max.	min.	min.	min.	min.	min.	max.	max.			
48,412	2,3	3,3	26	73,1	57	63	81	91	4,5	7	2,3	3,3	0,55	1,1	0,6
	2,3	0,8	26	73,1	57	63	83	91	4,5	7	2,3	0,8	0,55	1,1	0,6
	3,6	3,3	26	73,1	57	66	81	91	4,5	7	3,6	3,3	0,55	1,1	0,6
49,212	3,6	3,3	29	80,4	63	69	91	100	6	7,5	3,6	3,3	0,49	1,23	0,68
50	3	2,5	21	70,1	57	62	80	85	4,5	5	3	2,5	0,33	1,82	1
50,8	3,6	1,3	16	66,3	55	62	75	78	3	5	3,6	1,3	0,31	1,97	1,08
	3,6	1,3	16	66,3	55	62	75	78	3	4	3,6	1,3	0,31	1,97	1,08
	1,5	1,3	16	68,1	56	58	81	84	5	5,5	1,5	1,3	0,32	1,88	1,03
	3,6	1,3	16	68	56	59	81	84	5	5,5	3,6	1,3	0,32	1,88	1,03
	3,6	3,3	22	72,3	58	64	82	88	3,5	7	3,6	3,3	0,34	1,77	0,97
	3,6	0,8	20	73,1	58	64	86	90	5,5	6,5	3,6	0,8	0,33	1,82	1
	6,4	3,3	22	79,6	59	71	93	99	4	6	6,4	3,3	0,33	1,81	0,99
	3,6	3,3	28	80,3	61	67	90	99	4	6	3,6	3,3	0,34	1,79	0,98
	3,6	3,3	29	80,4	63	70	89	100	4	6	3,6	3,3	0,49	1,23	0,68
	3,6	0,8	29	80,4	63	70	91	100	4	6	3,6	0,8	0,49	1,23	0,68
	3,6	3,3	24	78,1	59	65	94	100	4	7,5	3,6	3,3	0,3	2,02	1,11
	3,6	3,3	37	85,7	65,3	74	91	105	4	10	3,6	3,3	0,88	0,68	0,37
3,6	3,2	38	86,8	67	79	102	116	3,5	8,5	3,6	3,2	0,74	0,81	0,45	
51,592	2	1,3	16	68,1	56	59	81	84	5	5,5	2	1,3	0,32	1,88	1,03
	2	0,8	16	68,1	56	59	81	84	5	5,5	2	0,8	0,32	1,88	1,03
53,975	2,3	2	22	73,2	61	64	78	84	4	5	2,3	2	0,55	1,1	0,6
	1,5	0,8	20	73,1	60	63	86	90	5,5	6,5	1,5	0,8	0,33	1,82	1
	3,6	3,3	29	80,4	63	73	89	100	6	7,5	3,6	3,3	0,49	1,23	0,68
	3,6	3,2	38	86,8	67	79	102	116	3,5	8,5	3,6	3,2	0,74	0,81	0,45
54,488	3,6	3,3	29	81	63	73	91	100	4	6	3,6	3,3	0,49	1,23	0,68
55	1,5	2,5	21	74,7	62	64	85	91	4,5	5,5	1,5	2,5	0,33	1,79	0,99
	3,5	0,8	19	75,7	61	67	89	92	5,5	5	3,5	0,8	0,35	1,69	0,93





Tapered roller bearings

Single row to ANSI/ABMA

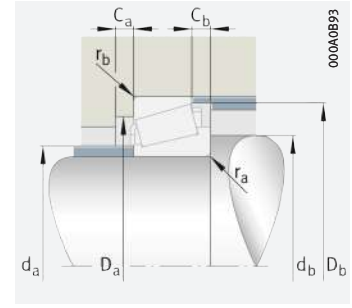
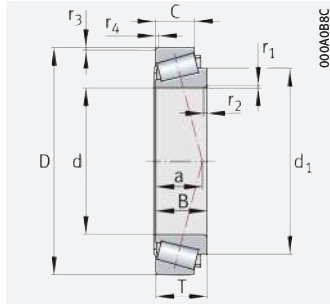

Mounting dimensions

d = 57,15 – 65,088 mm

Main dimensions					Basic load ratings		Fatigue limit load	Limiting speed	Mass	Designation
d	D	B	C	T	dyn. C_r	stat. C_{0r}	C_{ur}	n_G	m	▶ 573 1.12 ▶ 574 1.13 X-life ▶ 559
					N	N	N	min^{-1}	≈ kg	
57,15	87,312	18,258	14,288	18,258	56 000	88 000	10 400	8 100	0,418	KL507949-L507910
	96,838	21,945	15,875	21	76 000	95 000	11 200	7 500	0,593	K387-382-A
	96,838	21,946	15,875	21	76 000	95 000	11 200	7 500	0,59	K387-A-382-A
	96,838	21,946	20,274	25,4	76 000	95 000	11 200	7 500	0,66	K387-A-382-S
	98,425	21,946	17,826	21	76 000	95 000	11 200	7 500	0,637	K387-A-382
	104,775	29,317	24,605	30,162	111 000	141 000	17 000	6 900	1,07	K462-453-X
	104,775	29,317	24,605	30,162	111 000	141 000	17 000	6 900	1,08	K462-A-453-X
	110	29,317	27	27,795	111 000	141 000	17 000	6 900	1,26	K462-454
	112,712	30,162	23,812	30,162	137 000	192 000	23 800	6 200	1,41	K39580-39520
	112,712	30,162	23,812	30,162	137 000	192 000	23 800	6 200	1,42	K39581-39520
	112,712	30,048	23,812	30,162	119 000	176 000	22 000	6 300	1,44	K3979-3920
	117,475	30,162	23,812	30,162	124 000	189 000	23 900	5 900	1,62	K33225-33462
119,985	30,162	26,949	32,75	137 000	192 000	23 800	6 200	1,76	K39580-39528	
59,987	130,175	30,924	23,812	34,1	146 000	171 000	20 600	5 400	2,05	KHM911244-HM911210
60,325	122,238	38,354	29,718	38,1	193 000	255 000	32 000	5 800	2,09	KHM212044-HM212011
	130,175	33,338	23,812	36,513	146 000	171 000	20 600	5 400	2,13	KHM911245-HM911210
61,912	110	21,996	18,824	22	86 000	115 000	13 700	6 600	0,886	K392-394-A
	146,05	39,688	25,4	41,275	199 000	236 000	28 000	4 800	3,52	KH913842-H913810
62,738	101,6	25,4	19,845	25,4	91 000	135 000	16 700	7 000	0,78	K28995-28920
63,5	110	21,996	18,824	22	86 000	115 000	13 700	6 600	0,912	K395-394-A
	112,712	30,162	23,812	30,162	137 000	192 000	23 800	6 200	1,28	K39585-39520
	112,712	30,048	23,812	30,162	119 000	176 000	22 000	6 300	1,3	K3982-3920
	122,238	38,354	29,718	38,1	230 000	255 000	41 500	6 400	2,18	KHM212047-HM212011-XL
	130	36,17	29	36,937	168 000	238 000	29 500	5 600	2,29	K565-562-X
65	110	28	22,5	28	119 000	167 000	20 700	6 400	1,06	KJM511946-JM511910
65,088	135,755	56,007	44,45	53,975	275 000	385 000	49 000	5 200	3,74	AK6379-6320

medias ▶ <https://www.schaeffler.de/std/1F0D>



Dimensions					Mounting dimensions								Calculation factors			
d	r ₁ , r ₂	r ₃ , r ₄	a	d ₁	d _a	d _b	D _a	D _b	C _a	C _b	r _a	r _b	e	Y	Y ₀	
	min.	min.	≈	≈	max.	min.	min.	min.	min.	min.	min.	max.	max.			
57,15	1,5	1,5	17	73,9	62	65	79	83	2	3,8	1,5	1,5	0,39	1,54	0,85	
	2,3	0,8	19	75,7	62	66	89	92	4	5	2,3	0,8	0,35	1,69	0,93	
	3,6	0,8	19	76,6	62	69	89	92	4	5,1	3,6	0,8	0,35	1,69	0,93	
	3,6	2,3	23	76,6	62	69	87	91	2	6,5	3,6	2,3	0,35	1,69	0,93	
	3,6	0,8	19	76,6	62	69	90	92	4	3,1	3,6	0,8	0,35	1,69	0,93	
	2,3	3,3	24	80,3	67	70	92	98	3	5,5	2,3	3,3	0,34	1,79	0,98	
	2,3	3,3	24	80,3	67	70	92	98	3	5,5	2,3	3,3	0,34	1,79	0,98	
	2,3	2	22	80,3	67	70	96	100	2	2	2,3	2	0,34	1,79	0,98	
	3,6	3,3	24	89,5	66	72	101	107	6	6	3,6	3,3	0,34	1,77	0,97	
	7,9	3,3	24	90	66	81	101	107	6	6	7,9	3,3	0,34	1,77	0,97	
	3,6	3,3	27	89	66	72	99	106	4	6	3,6	3,3	0,4	1,49	0,82	
	3,6	3,3	28	95,6	68	74	104	112	3,5	6,5	3,6	3,3	0,44	1,38	0,76	
	3,6	0,8	26	89,5	66	72	101	107	2,5	5,5	3,6	0,8	0,34	1,77	0,97	
	59,987	3,6	3,3	42	97,3	74,4	84	109	123,6	4	8	3,6	3,3	0,82	0,73	0,4
60,325	7,9	3,3	27	91,5	70	85	108	116	4	7	7,9	3,3	0,34	1,78	0,98	
	5,2	3,3	42	97,3	74,4	87	109	123,6	6	4	5,2	3,3	0,82	0,73	0,4	
61,912	0,8	1,3	21	87,4	69	70	101	104,5	5	3	0,8	1,3	0,4	1,49	0,82	
	3,6	3,3	45	109,4	82,5	90	124	138	5	12,5	3,6	3,3	0,78	0,77	0,42	
62,738	3,6	3,3	23	82,9	69	75	90	97	3	5,5	3,6	3,3	0,43	1,41	0,78	
63,5	3,6	1,3	21	88,1	70	77	101	104,5	5	3	3,6	1,3	0,4	1,49	0,82	
	3,6	3,3	24	90	71	77	101	107	6	6	3,6	3,3	0,34	1,77	0,97	
	3,6	3,3	27	89	71	77	99	106	4	6	3,6	3,3	0,4	1,49	0,82	
	7,1	3,3	27	91,7	73	87	108	116	4	7	7,1	3,3	0,34	1,78	0,98	
	3,6	3	29	98,5	78	85	114	121	4	7,5	3,6	3	0,36	1,65	0,91	
65	3	2,5	24	87,7	72	78	99	105	3	5	3	2,5	0,4	1,49	0,82	
65,088	3,6	3,3	35	98,1	77	84	117	126	6	9	3,6	3,3	0,32	1,85	1,02	



Tapered roller bearings

Single row to ANSI/ABMA

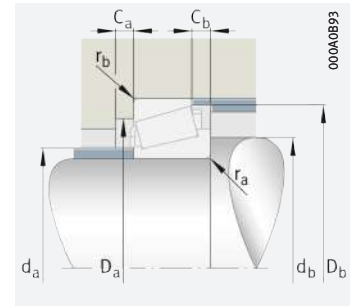
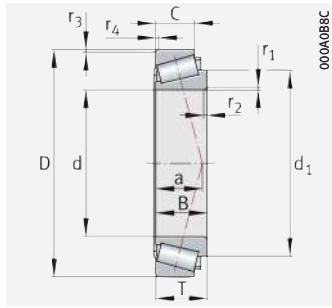

Mounting dimensions

d = 66,675 – 77,788 mm

Main dimensions					Basic load ratings		Fatigue limit load	Limiting speed	Mass	Designation
d	D	B	C	T	dyn. Cr	stat. Cor	C _{ur}	n _G	m	▶ 573 1.12 ▶ 574 1.13 X-life ▶ 559
					N	N	N	min ⁻¹	≈ kg	
66,675	110	21,996	18,824	22	86 000	115 000	13 700	6 600	0,855	K395-A-394-A
	110	21,996	18,824	22	86 000	115 000	13 700	6 600	0,801	K395-S-394-A
	112,712	30,162	23,812	30,162	137 000	192 000	23 800	6 200	1,2	K39590-39520
	112,712	30,048	23,812	30,162	119 000	176 000	22 000	6 300	1,31	K3984-3920
	112,712	30,048	23,812	30,162	119 000	176 000	22 000	6 300	1,31	K3994-3920
	122,238	38,354	29,718	38,1	193 000	255 000	32 000	5 800	1,93	KHM212049-HM212010
	122,238	38,354	29,718	38,1	193 000	255 000	32 000	5 800	1,93	KHM212049-HM212011
	136,525	41,275	31,75	41,275	270 000	295 000	46 500	5 700	2,77	KH414242-H414210-XL
68,263	110	21,996	18,824	22	86 000	115 000	13 700	6 600	0,781	K399-A-394-A
	110	21,996	18,824	22	86 000	115 000	13 700	6 600	0,781	K399-AS-394-A
69,85	112,712	21,996	15,875	22,225	85 000	115 000	13 700	6 400	0,798	KLM613449-LM613410
	117,475	30,162	23,812	30,162	124 000	189 000	23 900	5 900	1,21	K33275-33462
	120	32,545	26,195	32,545	152 000	224 000	28 000	5 800	1,53	K47487-47420
	120	29,007	24,237	29,794	112 000	150 000	18 300	6 000	1,32	K482-472
	127	36,17	28,575	36,512	168 000	238 000	29 500	5 600	1,95	K566-563
70	115	29	23	29	127 000	178 000	22 000	6 000	1,13	KJM612949-JM612910
71,438	120	32,545	26,195	32,545	152 000	224 000	28 000	5 800	1,61	K47490-47420
73,025	112,712	25,4	19,05	25,4	97 000	154 000	19 500	6 100	0,993	K29685-29620
	117,475	30,162	23,812	30,162	124 000	189 000	23 900	5 900	1,26	K33281-33462
	117,475	30,162	23,812	30,162	124 000	189 000	23 900	5 900	1,21	K33287-33462
75	115	25	19	25	124 000	165 000	26 500	6 500	0,919	KJLM714149-JLM714110-XL
	120	29,5	25	31	144 000	183 000	30 500	6 300	1,27	KJM714249-JM714210-XL
75,987	131,975	39	32	39	206 000	295 000	37 000	5 200	2,26	KHM215249-HM215210
76,2	127	31	22,225	30,162	136 000	199 000	24 400	5 500	1,51	K42687-42620
	133,35	29,769	22,225	30,163	134 000	200 000	24 100	5 200	1,95	K495-A-492-A
	133,35	39,688	32,545	39,688	183 000	310 000	39 500	5 000	2,43	KHM516442-HM516410
	133,35	39,688	32,545	39,688	183 000	310 000	39 500	5 000	2,43	KHM516447-HM516410
	136,525	29,769	22,225	30,163	134 000	200 000	24 100	5 200	2,05	K495-A-493
	142,138	46,1	33,338	44,45	206 000	290 000	35 500	5 000	2,99	KHM515745-HM515716
	142,138	46,1	33,338	44,45	206 000	290 000	35 500	5 000	2,99	KHM515745-HM515716
77,788	117,475	25,4	19,05	25,4	99 000	159 000	20 200	5 800	0,932	KLM814849-LM814810
	121,442	23,012	17,462	24,607	82 000	113 000	13 800	5 900	0,931	K34306-34478
	127	31	22,225	30,162	136 000	199 000	24 400	5 500	1,45	K42690-42620

medias ▶ <https://www.schaeffler.de/std/1FOE>



Dimensions					Mounting dimensions								Calculation factors			
d	r ₁ , r ₂	r ₃ , r ₄	a	d ₁	d _a	d _b	D _a	D _b	C _a	C _b	r _a	r _b	e	Y	Y ₀	
	min.	min.	≈	≈	max.	min.	min.	min.	min.	min.	min.	max.	max.			
66,675	0,8	1,3	21	87,4	73	73	101	104	4,5	2	0,8	1,3	0,4	1,49	0,82	
	3,6	1,3	21	88,1	73	79	101	104,5	5	3	3,6	1,3	0,4	1,49	0,82	
	3,6	3,3	24	90	75	82	101	107	6	6	3,6	3,3	0,34	1,77	0,97	
	3,6	3,3	27	89	74	80	99	106	4	6	3,6	3,3	0,4	1,49	0,82	
	5,6	3,3	27	89	74	84	99	106	4	6	5,6	3,3	0,4	1,49	0,82	
	3,6	1,5	27	91,5	75,5	82	108	116	4	8	3,6	1,5	0,34	1,78	0,98	
	3,6	3,3	27	91,5	75,5	82	108	116	4	8	3,6	3,3	0,34	1,78	0,98	
	3,6	3,3	30	101,2	81	85	121	129	6	9	3,6	3,3	0,36	1,67	0,92	
68,263	2,3	1,3	21	88,1	74	78	101	104,5	5	3	2,3	1,3	0,4	1,49	0,82	
	5,1	1,3	21	87,4	74	83	101	104,5	5	3	5,1	1,3	0,4	1,49	0,82	
69,85	1,5	0,8	22	91	76	78	104	107	3	6	1,5	0,8	0,42	1,44	0,79	
	3,6	3,3	28	95,5	77	84	104	112	4	6	3,6	3,3	0,44	1,38	0,76	
	3,6	3,3	27	96	78	84	107	114	4	6	3,6	3,3	0,36	1,67	0,92	
	3,6	2	26	93,9	77	83	107	112	3	5	3,6	2	0,38	1,56	0,86	
	3,6	3,3	29	98,5	78	85	112	120	4	7,5	3,6	3,3	0,36	1,65	0,91	
70	3	2,5	26	92,5	77	83	103	110	5	6	3	2,5	0,43	1,39	0,77	
71,438	3,6	3,3	27	95,2	79	86	107	114	4	6	3,6	3,3	0,36	1,67	0,92	
73,025	3,6	3,3	26	95,6	80	86	101	109	5	6	3,6	3,3	0,49	1,23	0,68	
	3,6	3,3	28	95,5	79	87	104	112	4	6	3,6	3,3	0,44	1,38	0,76	
	3,6	3,3	28	95,6	79	87	104	112	4	6	3,6	3,3	0,44	1,38	0,76	
75	3	2,5	26	97	81	87	104	110	4,5	6	3	2,5	0,46	1,31	0,72	
	3	2,5	29	99,4	83	88	108	115	4	6	3	2,5	0,44	1,35	0,74	
75,987	7,1	3,6	30	103,2	85	98	118	126	7	7	7,1	3,6	0,33	1,8	0,99	
76,2	3,6	3,3	27	102,6	84	90	114	121	4	8	3,6	3,3	0,42	1,43	0,79	
	3,6	3,3	30	110,6	86	92	120	128	4	7,5	3,6	3,3	0,44	1,35	0,74	
	3,6	3,3	32	110,6	87	93	118	128	5	7	3,6	3,3	0,4	1,49	0,82	
	3,6	3,3	32	110,6	87	93	118	128	5	8	3,6	3,3	0,4	1,49	0,82	
	3,6	3,3	30	110,6	86	92	122	130	4	7,5	3,6	3,3	0,44	1,35	0,74	
	3,6	3,3	33	107,2	87	92	124	133	6	10	3,6	3,3	0,39	1,55	0,85	
77,788	3,6	3,3	28	99,2	85	91	105	113	3	6	3,6	3,3	0,51	1,18	0,65	
	3,6	2	26	99,7	84	90	110	116	3	7	3,6	2	0,45	1,33	0,73	
	3,6	3,3	27	102,6	85	91	114	121	4	8	3,6	3,3	0,42	1,43	0,79	



Tapered roller bearings

Single row to ANSI/ABMA

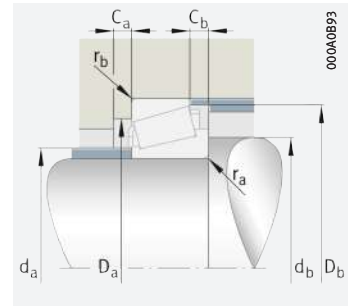
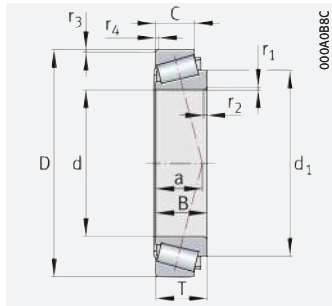

Mounting dimensions

d = 79,975 – 99,975 mm

Main dimensions					Basic load ratings		Fatigue limit load	Limiting speed	Mass	Designation ▶ 573 1.12 ▶ 574 1.13 X-life ▶ 559
d	D	B	C	T	dyn. Cr	stat. Cor	C _{ur}	n _G	m	
					N	N	N	min ⁻¹	≈ kg	
79,975	146,975	40	32,5	40	233 000	355 000	43 000	4 600	3,02	KHM218238-HM218210
80	130	34	28,5	35	160 000	239 000	29 500	5 300	1,74	KJM515649-JM515610
80,963	136,525	29,769	22,225	30,162	134 000	200 000	24 100	5 200	1,91	K496-493
82,55	133,35	33,338	26,195	33,338	153 000	235 000	29 000	5 200	1,94	AK47686-47620
	133,35	39,688	32,545	39,688	183 000	310 000	39 500	5 000	2,32	KHM516449-HM516410
	136,525	29,769	22,225	30,163	134 000	200 000	24 100	5 200	1,67	K495-493
	139,992	36,098	28,575	36,512	177 000	265 000	32 000	5 000	2,25	K580-572
	146,05	41,275	31,75	41,275	250 000	305 000	48 000	5 200	2,79	K663-653-XL
84,138	133,35	29,769	22,225	30,163	134 000	200 000	24 100	5 200	1,53	K498-492-A
	136,525	29,769	22,225	30,163	134 000	200 000	24 100	5 200	1,81	K498-493
85	130	29	24	30	130 000	205 000	25 500	5 200	1,37	KJM716649-JM716610
85,725	133,35	29,769	22,225	30,162	134 000	200 000	24 100	5 200	1,47	K497-492-A
	136,525	29,769	22,225	30,162	134 000	200 000	24 100	5 200	1,75	K497-493
	142,138	42,862	34,133	42,862	216 000	350 000	43 500	4 700	2,72	KHM617049-HM617010
88,9	152,4	39,688	30,163	39,688	244 000	350 000	41 000	4 500	2,94	KHM518445-HM518410
89,975	146,975	40	32,5	40	233 000	355 000	43 000	4 600	2,57	KHM218248-HM218210
90	145	34	27	35	177 000	265 000	32 000	4 700	2,15	KJM718149-A-JM718110
	145	34	27	35	177 000	265 000	32 000	4 700	2,15	KJM718149-JM718110
92,075	146,05	34,925	26,195	33,338	167 000	275 000	33 000	4 650	2,11	K47890-47820
	146,05	34,925	26,195	33,338	167 000	275 000	33 000	4 650	1,98	K47896-47820
	150	36,322	27	35,992	182 000	285 000	34 000	4 600	2,41	K598-A-593-X
95	135	20	14	20	83 000	138 000	16 400	5 100	0,893	KJL819349-JL819310
	150	34	27	35	182 000	285 000	34 000	4 600	2,26	KJM719149-JM719113
95,25	152,4	36,322	30,162	39,688	215 000	285 000	44 500	5 000	2,57	K594-A-592-A-XL
	152,4	36,322	30,162	39,688	215 000	285 000	44 000	5 000	2,55	K594-592-A-XL
	168,275	41,275	30,162	41,275	265 000	350 000	53 000	4 550	3,78	K683-672-XL
96,838	148,43	28,971	21,433	28,575	139 000	216 000	25 500	4 650	1,75	K42381-42584
	188,912	46,038	31,75	50,8	270 000	340 000	38 000	3 550	5,62	K90381-90744
99,975	156,975	42	34	42	250 000	410 000	48 500	4 250	2,94	KHM220149-HM220110

medias ▶ <https://www.schaeffler.de/std/1FOF>



Dimensions					Mounting dimensions								Calculation factors		
d	r ₁ , r ₂	r ₃ , r ₄	a	d ₁	d _a	d _b	D _a	D _b	C _a	C _b	r _a	r _b	e	Y	Y ₀
	min.	min.	≈	≈	max.	min.	min.	min.	min.	min.	max.	max.			
79,975	7,1	3,6	32	117,5	91	104	133	141	7	7,5	7,1	3,6	0,33	1,8	0,99
80	3	2,5	29	105,4	88	94	117	125	4,5	6,5	3	2,5	0,39	1,54	0,85
80,963	3,6	3,3	30	110,6	89	95	122	130	4	7,5	3,6	3,3	0,44	1,35	0,74
82,55	3,6	3,3	30	108,2	90	97	119	128	5	7	3,6	3,3	0,4	1,48	0,82
	3,6	3,3	32	110,5	92	99	118	128	5	7	3,6	3,3	0,4	1,49	0,82
	3,6	3,3	30	110,6	90	97	122	130	4	7,5	3,6	3,3	0,44	1,35	0,74
	3,6	3,3	31	110,7	91	98	125	133	5	7,5	3,6	3,3	0,4	1,49	0,82
84,138	3,6	3,3	33	114,5	92	99	131	139	5	8	3,6	3,3	0,41	1,47	0,81
	3,6	3,3	30	110,6	91	98	120	128	4	7,5	3,6	3,3	0,44	1,35	0,74
85	3,6	3,3	30	110,6	91	98	122	130	4	7,5	3,6	3,3	0,44	1,35	0,74
	3	2,5	30	109	92	98	117	125	4	6	3	2,5	0,44	1,35	0,74
85,725	3,6	3,3	30	110,6	93	99	120	128	4	7,5	3,6	3,3	0,44	1,35	0,74
	3,6	3,3	30	110,6	93	99	122	130	4	7,5	3,6	3,3	0,44	1,35	0,74
	4,8	3,3	36	115,8	95	106	125	137	5	8	4,8	3,3	0,43	1,39	0,76
88,9	6,4	3,3	34	119,5	100	110	134	146	4	8,5	6,4	3,3	0,4	1,49	0,82
89,975	7,1	3,6	32	119	99	112	133	141	5,5	7,5	7,1	3,6	0,33	1,8	0,99
90	6	2,5	33	118,5	99	111	131	139	4	7	6	2,5	0,44	1,35	0,74
	3	2,5	33	118,5	99	105	131	139	4	7	3	2,5	0,44	1,35	0,74
92,075	3,6	3,3	33	122,2	101	107	131	140	4,5	7	3,6	3,3	0,45	1,34	0,74
	3,6	3,3	33	122,2	101	107	131	140	4,5	7	3,6	3,3	0,45	1,34	0,74
	6,4	3,3	33	122,7	103	109	130	142	7	8	6,4	3,3	0,44	1,36	0,75
95	5	2,5	31	116,8	102	111	123	129	3,5	5,5	5	2,5	0,58	1,03	0,57
	3	2,5	33	121,4	104	109	135	143	4	6	3	2,5	0,44	1,36	0,75
95,25	5,1	3,3	37	122	103	109	128	141	3	9	5,1	3,3	0,44	1,36	0,75
	3,6	3,3	37	122	103	109	128	141	3	9	3,6	3,3	0,44	1,36	0,75
	3,6	3,3	38	133,5	106	113	149	160	5	9	3,6	3,3	0,47	1,28	0,7
96,838	3,6	3	32	123,3	104	110	134	142	4	6,5	3,6	3	0,49	1,22	0,67
	3,5	3,3	64	142,9	113	125	161	179	2,5	12	3,5	3,3	0,87	0,69	0,38
99,975	7,9	3,6	33	128,7	109	120	140	150	5	8	7,9	3,6	0,33	1,8	0,99



Tapered roller bearings

Single row to ANSI/ABMA

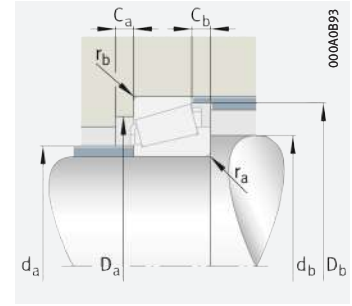
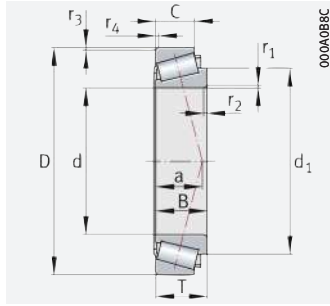

Mounting dimensions

d = 100 – 152,4 mm

Main dimensions					Basic load ratings		Fatigue limit load	Limiting speed	Mass	Designation
d	D	B	C	T	dyn. Cr	stat. Cor	C _{ur}	n _G	m	▶ 573 1.12 ▶ 574 1.13 X-life ▶ 559
					N	N	N	min ⁻¹	≈ kg	
100	155	35	28	36	187 000	305 000	36 000	4 300	2,38	KJM720249-JM720210
101,6	168,275	41,275	30,162	41,275	265 000	350 000	53 000	4 550	3,42	K687-672-XL
106,362	165,1	36,512	26,988	36,512	244 000	335 000	50 000	4 500	2,79	AK56418-56650-XL
107,95	158,75	21,438	15,875	23,02	100 000	164 000	18 500	4 400	1	K37425-37625
	161,925	34,925	26,988	34,925	175 000	305 000	35 000	4 150	2,46	K48190-48120
	165,1	36,512	26,988	36,512	244 000	335 000	50 000	4 500	2,71	AK56425-56650-XL
	168,275	36,512	26,988	36,512	244 000	335 000	50 000	4 500	2,89	AK56425-56662-XL
109,538	158,75	21,438	15,875	23,02	100 000	164 000	18 500	4 400	1,36	K37431-37625
	158,75	21,438	15,875	23,02	100 000	164 000	18 500	4 400	1,35	K37431-A-37625
109,987	159,987	34,925	26,988	34,925	174 000	340 000	40 500	4 200	2,36	KLM522548-LM522510
	159,987	34,925	26,988	34,925	174 000	340 000	40 500	4 200	2,34	KLM522549-LM522510
	164,737	34,925	32,131	37,312	174 000	340 000	40 500	4 200	2,71	KLM522549-LM522518
110	165	35	26,5	35	188 000	305 000	35 500	4 050	2,53	KJM822049-JM822010
	180	46	38	47	320 000	510 000	58 000	3 750	5,03	KJHM522649-JHM522610
114,3	177,8	41,275	30,162	41,275	285 000	395 000	57 000	4 150	3,63	K64450-64700-XL
	212,725	66,675	53,975	66,675	580 000	720 000	105 000	3 650	10	K938-932-XL
119,957	195,262	57,15	44,45	53,975	375 000	630 000	72 000	3 500	6,4	KHM124649-HM124618
120	180	36	26	36	221 000	355 000	40 000	3 750	3	KJM624649-JM624610
120,65	190,5	46,038	34,925	46,038	305 000	490 000	55 000	3 500	4,77	KHM624749-HM624710
127	234,95	63,5	49,212	63,5	520 000	810 000	101 000	2 900	12	K95500-95925
133,35	196,85	46,038	38,1	46,038	370 000	570 000	82 000	3 700	4,65	K67390-67322-XL
	234,95	63,5	49,212	63,5	520 000	810 000	101 000	2 900	12,3	K95525-95925
136,525	194,975	33	27,5	33	223 000	400 000	43 500	3 450	3,18	KLM229139-LM229110
139,7	187,325	29,37	23,02	28,575	180 000	350 000	39 000	3 600	2,21	KLM328448-LM328410
	254	66,675	47,625	66,675	580 000	970 000	117 000	2 650	14,3	K99550-99100
	295,275	87,312	57,15	82,55	830 000	1 120 000	130 000	2 450	24,1	KHH231649-HH231615
142,875	194,975	33	27,5	33	223 000	400 000	43 500	3 450	2,79	KLM229146-LM229110
	200,025	39,688	34,13	41,275	255 000	510 000	57 000	3 300	3,87	K48684-48620
	200,025	39,688	34,13	41,275	255 000	510 000	57 000	3 300	3,91	K48685-48620
146,05	193,675	28,575	23,02	28,575	215 000	335 000	46 500	3 850	2,24	AK36690-36620-XL
150	205	28,575	21,438	28,575	173 000	315 000	33 000	3 300	2,65	KJL730646-JL730612
	307,975	93,662	66,675	88,9	960 000	1 290 000	146 000	2 260	28,8	K107060-107105 KHH234048-HH234010

medias ▶ <https://www.schaeffler.de/std/1F10>



Dimensions					Mounting dimensions								Calculation factors		
d	r ₁ , r ₂	r ₃ , r ₄	a	d ₁	d _a	d _b	D _a	D _b	C _a	C _b	r _a	r _b	e	Y	Y ₀
	min.	min.	≈	≈	max.	min.	min.	min.	min.	min.	max.	max.			
100	3	2,5	36	127,5	109	115	140	149	4	6,5	3	2,5	0,47	1,27	0,7
101,6	3,6	3,3	38	133,5	112	118	149	160	7	11	3,6	3,3	0,47	1,28	0,7
106,362	3,6	3,3	38	137,1	117	123	145	159	4	8	3,6	3,3	0,5	1,21	0,66
107,95	3,6	3,3	37	134,2	115	122	143	152	3,5	7	3,6	3,3	0,61	0,99	0,54
	3,6	3,3	39	138,1	116	122	146	156	3,5	7,5	3,6	3,3	0,51	1,19	0,65
	3,6	3,3	38	137,1	117	123	145	159	4	8	3,6	3,3	0,5	1,21	0,66
	3,6	3,3	38	137,1	117	123	145	159	4	8	3,6	3,3	0,5	1,21	0,66
109,538	3,6	3,3	37	134,2	116	123	143	152	3	7	3,6	3,3	0,61	0,99	0,54
	5	3,3	37	134,2	116	126	143	152	3	7	5	3,3	0,61	0,99	0,54
109,987	8,1	3,3	33	138,2	118	133	146	154	4	8	8,1	3,3	0,4	1,49	0,82
	3,6	3,3	33	138,2	118	124	146	154	4	7,5	3,6	3,3	0,4	1,49	0,82
	3,6	2,3	36	138,2	118	124	149	157	4	4	3,6	2,3	0,4	1,49	0,82
110	3	2,5	38	139	119	124	149	159	4,5	8	3	2,5	0,5	1,21	0,66
	3	2,5	41	145	122	127	162	172	5	7	3	2,5	0,41	1,48	0,81
114,3	3,6	3,3	43	147,3	125	131	160	172	5	9	3,6	3,3	0,52	1,16	0,64
	7,1	3,3	47	153,5	128	141	187	193	5	10	7,1	3,3	0,33	1,84	1,01
119,957	3	3,3	38	151,8	131	137	168	179	5	9,5	3	3,3	0,26	2,27	1,25
120	3,6	1,5	37	149,6	128	135	166	173	5,5	9,5	3,6	1,5	0,43	1,4	0,77
120,65	3,6	1,5	43	155,1	132	138	174	184	5	8,5	3,6	1,5	0,43	1,41	0,77
127	6,4	3,3	50	179,2	142	154	209	217	7	14	6,4	3,3	0,37	1,62	0,89
133,35	3,6	3,3	40	165,5	143	149	180	189	4	6,5	3,6	3,3	0,34	1,74	0,96
	9,7	3,3	50	179,2	148	166	209	217	8	12	9,7	3,3	0,37	1,62	0,89
136,525	3,6	3,6	33	168,2	146	152	182	190	5,5	7,5	3,6	3,6	0,33	1,8	0,99
139,7	1,5	1,5	32	163,7	147	149	176	182	5	5	1,5	1,5	0,36	1,69	0,93
	7,1	3,3	55	201,5	156	170	227	238	8	13,5	7,1	3,3	0,41	1,47	0,81
	9,7	6,4	56	199,1	161	177	258	264	9	19	9,7	6,4	0,32	1,88	1,04
142,875	3,6	3,6	33	168	150	157	182	190	5	5,5	3,6	3,6	0,33	1,8	0,99
	7,9	3,3	38	172,3	151	158	185	193	5	7	7,9	3,3	0,34	1,78	0,98
	3,6	3,3	38	172,3	151	158	185	193	5	7	3,6	3,3	0,34	1,78	0,98
146,05	1,5	1,5	33	168,2	153	155	180	186	5	5	1,5	1,5	0,37	1,63	0,9
150	2,5	2	40	178,3	158	164	190	198	4	7	2,5	2	0,46	1,31	0,72
152,4	6,4	6,4	60	204	171	181	237	249	8	13,5	6,4	6,4	0,39	1,55	0,85
	9,7	6,9	63	219,2	179	191	276	285,4	9	17	9,7	6,9	0,33	1,84	1,01





Tapered roller bearings

Single row to ANSI/ABMA

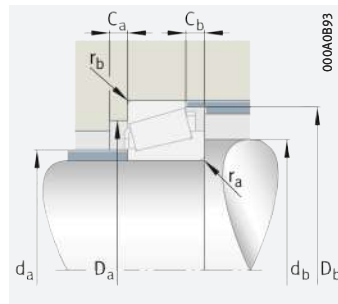
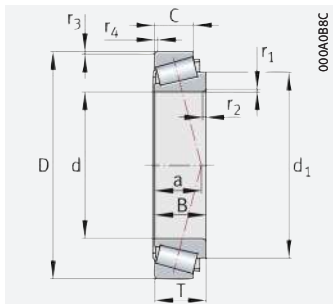

Mounting dimensions

d = 160 – 673,1 mm

Main dimensions					Basic load ratings		Fatigue limit load	Limiting speed	Mass	Designation
d	D	B	C	T	dyn. C_r	stat. C_{0r}	C_{ur}	n_G	m	▶ 573 1.12 ▶ 574 1.13 X-life ▶ 559
					N	N	N	min^{-1}	≈ kg	
160	240	44,5	37	46	345 000	650 000	78 000	2 700	7,14	KJM734445-JM734410
	252,413	69,85	52,388	63,5	520 000	900 000	110 000	2 650	13	KHM133448-HM133416
165,1	225,425	39,688	33,338	41,275	239 000	520 000	56 000	2 950	5,03	K46790-46720
	336,55	95,25	69,85	92,075	1 280 000	1 550 000	193 000	2 280	37,1	KHH437549-HH437510-XL
170	240	44,5	37	46	345 000	650 000	78 000	2 700	6,25	KJM734449-JM734410
177,8	227,012	30,162	23,02	30,162	221 000	395 000	51 000	3 250	3,17	K36990-36920-XL
180	250	45	37	47	360 000	710 000	84 000	2 600	6,8	KJM736149-JM736110
184,15	234,95	33	28	34	234 000	485 000	33 500	2 800	3,46	KLM236749-LM236710
	235,229	33	28	34	234 000	485 000	33 500	2 800	3,47	KLM236749-LM236710-A
190	260	44	36,5	46	370 000	750 000	89 000	2 490	7,06	KJM738249-JM738210
190,5	266,7	46,833	38,1	47,625	415 000	730 000	95 000	2 700	8,19	K67885-67820-XL
196,85	257,175	39,688	30,163	39,688	260 000	590 000	69 000	2 550	5,4	KLM739749-LM739710
199,949	282,575	49,212	36,512	46,038	435 000	810 000	103 000	2 500	9,6	K67982-67920-XL
200,025	276,225	46,038	34,133	42,862	380 000	720 000	82 000	2 420	7,85	KLM241147-LM241110
203,2	276,225	42,862	34,133	42,862	380 000	720 000	82 000	2 420	7,21	KLM241149-LM241110
203,987	276,225	46,038	34,133	42,862	380 000	720 000	82 000	2 420	7,25	KLM241148-LM241110
	276,225	46,038	34,132	42,862	380 000	720 000	82 000	2 420	7,21	KLM241148-LM241111
206,375	282,575	46,038	36,512	46,038	435 000	810 000	103 000	2 500	8,6	K67985-67920-XL
212,725	285,75	46,038	34,925	46,038	360 000	790 000	79 000	2 240	8,96	KLM742745-LM742710
215,9	285,75	46,038	34,925	46,038	360 000	790 000	79 000	2 240	7,86	KLM742749-LM742710
216,408	285,75	49,212	34,925	46,038	360 000	790 000	79 000	2 240	7,85	KLM742747-LM742710
216,713	285,75	49,213	34,925	46,038	360 000	790 000	79 000	2 240	7,77	KLM742747-A-LM742710
223,838	295,275	46,038	34,925	46,038	370 000	830 000	82 000	2 170	8,29	KLM844049-LM844010
228,6	295,275	31,75	23,813	33,338	250 000	510 000	56 000	2 320	5,31	AK544090-544116
230,188	317,5	52,388	36,512	47,625	455 000	830 000	91 000	2 090	11,1	KLM245846-LM245810
231,775	317,5	52,388	36,512	47,625	540 000	830 000	103 000	2 300	10,8	KLM245848-LM245810-XL
234,95	314,325	49,213	36,512	49,212	480 000	990 000	110 000	2 070	10,3	KLM545849-LM545810
279,982	380,898	65,088	49,212	65,088	690 000	1 610 000	171 000	1 670	21,3	KLM654642-LM654610
285,75	380,898	65,088	49,212	65,088	690 000	1 610 000	171 000	1 670	19,9	KLM654649-LM654610
317,5	447,675	85,725	68,262	85,725	1 210 000	2 600 000	260 000	1 420	41,6	KHM259049-HM259010
596,9	685,8	31,75	25,4	31,75	410 000	1 120 000	84 000	1 010	18,7	K680235-680270
673,1	793,75	61,912	49,212	66,675	1 060 000	3 250 000	247 000	820	53,3	KLL481448-LL481411

medias ▶ <https://www.schaeffler.de/std/1F11>



Dimensions					Mounting dimensions								Calculation factors		
d	r ₁ , r ₂	r ₃ , r ₄	a	d ₁	d _a	d _b	D _a	D _b	C _a	C _b	r _a	r _b	e	Y	Y ₀
	min.	min.	≈	≈	max.	min.	min.	min.	min.	min.	max.	max.			
160	3	2,5	50	205,5	173	178	222	232	6	9	3	2,5	0,44	1,37	0,75
	1,5	3,3	46	199,7	174	178	221	233	7	11,5	1,5	3,3	0,26	2,27	1,25
165,1	3,6	3,3	45	199	174	181	209	218	2,5	6,5	3,6	3,3	0,38	1,57	0,86
	3,3	6,4	72	239,5	197	196	280	308	10	22	3,3	6,4	0,37	1,62	0,89
170	3	2,5	50	205,5	180	185	222	232	6	9	3	2,5	0,44	1,37	0,75
177,8	1,5	1,5	43	203,6	186	188	214	221	4	7	1,5	1,5	0,44	1,36	0,75
180	3	2,5	54	217	190,5	196	232	242,6	5	8	3	2,5	0,48	1,25	0,69
184,15	2	2	39	209,8	191	195	224	229	4	5	2	2	0,33	0,99	1,79
	2	2	39	209,8	191	195	224	229	4	5	2	2	0,33	0,99	1,79
190	3	2,5	55	226	200	206	242	252	5	7,5	3	2,5	0,48	0,69	1,26
190,5	3,6	3,3	58	233	206	209	239	257	4	7,5	3,6	3,3	0,48	1,26	0,69
196,85	3,6	3,3	51	230	206	213	239	251	4	7,5	3,6	3,3	0,45	0,74	1,34
199,949	3,6	3,3	62	248,5	221	220	254	272	5	8	3,6	3,3	0,51	1,18	0,65
200,025	3,6	3,3	45	240,6	214	219	260	267	5	9	3,6	3,3	0,32	1,04	1,88
203,2	3,6	3,3	45	240,4	214	219	260	267	5	8	3,6	3,3	0,32	1,04	1,88
203,987	3,6	3,3	45	240,6	214	219	260	267	5	9	3,6	3,3	0,32	1,04	1,88
	3,6	3,3	45	240,6	214	219	260	267	5	8	3,6	3,3	0,32	1,04	1,88
206,375	3,6	3,3	62	248,5	221	220	254	272	5	8	3,6	3,3	0,51	1,18	0,65
212,725	3,6	3,3	61	255	225	230	266	279	5	10,5	3,6	3,3	0,48	0,69	1,25
215,9	3,6	3,3	61	255	227	233	266	279	5	11	3,6	3,3	0,48	0,69	1,25
216,408	3,6	3,3	61	254,1	227	233	266	279	5	11	3,6	3,3	0,48	0,69	1,25
216,713	3,6	3,3	61	254,1	227	233	266	279	5	11	3,6	3,3	0,48	0,69	1,25
223,838	3,6	3,3	64	263,5	235	241	275	288	5	11	3,6	3,3	0,5	0,66	1,2
228,6	3,6	3,3	50	262,5	240	244	280	287	4	9,5	3,6	3,3	0,4	0,82	1,49
230,188	3,3	3,3	50	270	245	248	299	306	10	11	3,3	3,3	0,32	1,04	1,88
231,775	3,3	3,3	50	270	247	248	296	304	10	11	3,3	3,3	0,32	1,88	1,04
234,95	3,6	3,3	58	274,2	246	252	296	306	5	10	3,6	3,3	0,4	0,83	1,51
279,982	3,6	3,3	76	334,5	298	302	356	368	4,5	12	3,6	3,3	0,43	0,76	1,39
285,75	3,6	3,3	76	334,5	302	306	356	368	7	16	3,6	3,3	0,43	0,76	1,39
317,5	3,6	3,3	80	380,4	337	341	418	428	9	13,5	3,6	3,3	0,33	0,99	1,8
596,9	3,6	3,3	126	637	615	621	659	667	8	6	3,6	3,3	0,53	0,63	1,14
673,1	6,4	6,4	117	725	690	702	765	771	7	14	6,4	6,4	0,36	0,92	1,67





Tapered roller bearings

Matched pairs

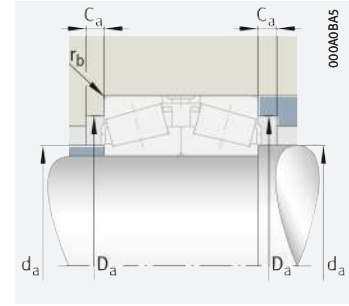
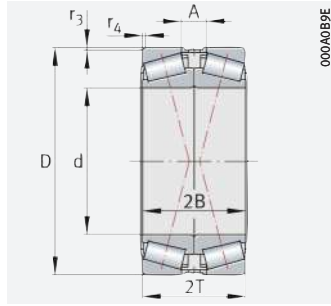

Mounting dimensions

d = 40 – 140 mm

Main dimensions				Basic load ratings for bearing pair		Fatigue limit load Bearing pair	Limiting speed Bearing pair	Speed rating Bearing pair	Mass for bearing pair	Designation ▶ 573 1.12 ▶ 574 1.13 X-life ▶ 559
d	D	2B	2T	dyn. Cr	stat. Cor	Cur	nG	nDr	m	
				N	N	N	min ⁻¹	min ⁻¹	≈ kg	
40	90	46	50,5	153 000	165 000	24 200	8 700	5 100	1,52	31308-XL-DF-A115-155
	90	46	50,5	153 000	165 000	24 200	8 700	5 100	1,52	31308-XL-DF-A50-90
60	110	44	47,5	210 000	246 000	36 500	7 500	4 250	1,97	30212-XL-DF-A100-140
80	125	58	58	280 000	425 000	68 000	6 000	3 450	2,66	32016-X-XL-DF-A140-170
	125	58	58	280 000	425 000	68 000	6 000	3 450	2,66	32016-X-XL-DF-A150-200
	125	58	58	280 000	425 000	68 000	6 000	3 450	2,66	32016-X-XL-DF-A25-50
85	130	58	58	285 000	450 000	71 000	5 700	3 250	2,8	32017-X-XL-DF-A170-220
	130	58	58	285 000	450 000	71 000	5 700	3 250	2,8	32017-X-XL-DF-A190-230
90	140	64	64	335 000	510 000	80 000	5 400	3 200	3,64	32018-X-XL-DF-A170-220
	160	80	85	530 000	720 000	109 000	4 800	2 650	7,12	32218-XL-DF-A220-270
100	150	64	64	350 000	570 000	87 000	4 950	2 900	4,02	32020-X-XL-DF-A220-270
	180	68	74	430 000	650 000	71 000	4 000	2 650	7,82	30220-A-DF-A180-220
	180	68	74	430 000	650 000	71 000	4 000	2 650	7,82	30220-A-DF-A220-270
	180	68	74	430 000	650 000	71 000	4 000	2 650	7,82	30220-A-DF-A250-280
105	160	70	70	410 000	660 000	99 000	4 650	2 650	5,11	32021-X-XL-DF-A280-330
	190	100	106	780 000	1 110 000	163 000	4 000	2 110	13	32221-XL-DF-A230-280
110	170	76	76	490 000	790 000	117 000	4 350	2 440	6,31	32022-X-XL-DF-A170-230
	170	76	76	490 000	790 000	117 000	4 350	2 440	6,31	32022-X-XL-DF-A220-270
	170	76	76	490 000	790 000	117 000	4 350	2 440	6,31	32022-X-XL-DF-A90-130
	240	114	126	940 000	1 170 000	157 000	3 100	1 890	26,2	31322-X-XL-DF-A200-250
	240	114	126	940 000	1 170 000	157 000	3 100	1 890	26,2	31322-X-XL-P5-DF-A120-160
	240	114	126	940 000	1 170 000	157 000	3 100	1 890	26,2	31322-X-XL-P5-DF-A140-180
	240	114	126	940 000	1 170 000	157 000	3 100	1 890	26,2	31322-X-XL-P5-DF-A60-100
120	180	76	76	510 000	840 000	123 000	4 050	2 240	6,76	32024-X-XL-DF-A230-280
130	200	90	90	660 000	1 100 000	158 000	3 650	1 960	9,94	32026-X-XL-DF-A125-175
	200	90	90	660 000	1 100 000	158 000	3 650	1 960	9,94	32026-X-XL-DF-A200-250
	200	90	90	660 000	1 100 000	158 000	3 650	1 960	9,94	32026-X-XL-DF-A250-300
140	210	90	90	690 000	1 180 000	168 000	3 450	1 810	11,1	32028-X-XL-DF-A250-300

medias ▶ <https://www.schaeffler.de/std/1F12>



Dimensions			Mounting dimensions					Calculation factors			
d	r ₃ , r ₄	A	d _a	D _a	D _a	C _a	r _b	e	Y ₁	Y ₂	Y ₀
	min.		max.	min.	max.	min.	max.				
40	1,5	16,5	51	71	81	4	1,5	0,83	0,82	1,22	0,8
	1,5	16,5	51	71	81	4	1,5	0,83	0,82	1,22	0,8
60	1,5	9,5	70	96	101	4	1,5	0,41	1,67	2,48	1,63
80	1,5	14	89	112	117	6	1,5	0,42	1,6	2,38	1,56
	1,5	14	89	112	117	6	1,5	0,42	1,6	2,38	1,56
	1,5	14	89	112	117	6	1,5	0,42	1,6	2,38	1,56
85	1,5	14	94	117	122	6	1,5	0,44	1,53	2,27	1,49
	1,5	14	94	117	122	6	1,5	0,44	1,53	2,27	1,49
90	1,5	16	100	125	131	6	1,5	0,42	1,6	2,38	1,56
	2	17	102	138	150	5	2	0,42	1,61	2,39	1,57
100	1,5	16	109	134	141	6	1,5	0,46	1,47	2,19	1,44
	2,5	16	116	157	168	5	2,5	0,42	1,61	2,39	1,57
	2,5	16	116	157	168	5	2,5	0,42	1,61	2,39	1,57
	2,5	16	116	157	168	5	2,5	0,42	1,61	2,39	1,57
105	2	18	116	143	150	6	2	0,44	1,52	2,26	1,49
	2,5	20	120	161	178	5	2,5	0,42	1,61	2,39	1,57
110	2	18	122	152	160	7	2	0,43	1,57	2,34	1,53
	2	18	122	152	160	7	2	0,43	1,57	2,34	1,53
	2	18	122	152	160	7	2	0,43	1,57	2,34	1,53
	3	50	135	188	226	7	3	0,83	0,82	1,22	0,8
	3	50	135	188	226	7	3	0,83	0,82	1,22	0,8
	3	50	135	188	226	7	3	0,83	0,82	1,22	0,8
	3	50	135	188	226	7	3	0,83	0,82	1,22	0,8
120	2	18	131	161	170	7	2	0,46	1,47	2,19	1,44
130	2	22	144	178	190	8	2	0,43	1,55	2,31	1,52
	2	22	144	178	190	8	2	0,43	1,55	2,31	1,52
	2	22	144	178	190	8	2	0,43	1,55	2,31	1,52
140	2	22	153	187	200	8	2	0,46	1,47	2,19	1,44



Tapered roller bearings

Matched pairs

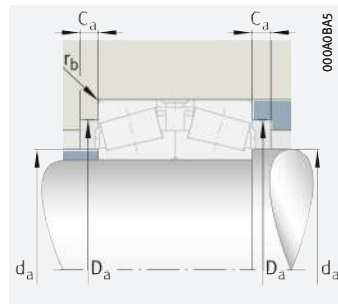
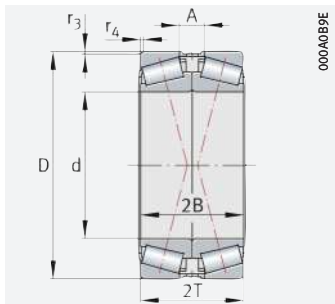

Mounting dimensions

d = 150 – 260 mm

Main dimensions				Basic load ratings for bearing pair		Fatigue limit load Bearing pair C_{ur}	Limiting speed Bearing pair n_G	Speed rating Bearing pair n_{dr}	Mass for bearing pair m	Designation
d	D	2B	2T	dyn. C_r	stat. C_{0r}					
				N	N	N	min^{-1}	min^{-1}	≈ kg	
150	225	96	96	780 000	1 350 000	188 000	3 200	1 650	13,5	32030-X-XL-DF-A120-170
	225	96	96	780 000	1 350 000	188 000	3 200	1 650	13,5	32030-X-XL-DF-A280-330
	225	118	118	950 000	1 770 000	249 000	3 150	1 580	16,7	33030-XL-DF-A0-35
170	310	172	182	1 980 000	3 100 000	410 000	2 350	1 090	59,2	32234-XL-DF-A320-370
	310	172	182	1 980 000	3 100 000	410 000	2 350	1 090	59,2	32234-XL-DF-A350-410
	310	172	182	1 980 000	3 100 000	410 000	2 350	1 090	59,2	32234-XL-DF-A490-540
180	280	128	128	1 270 000	2 200 000	290 000	2 550	1 250	28,9	32036-X-XL-DF-A240-290
	280	128	128	1 270 000	2 200 000	290 000	2 550	1 250	28,9	32036-X-XL-DF-A320-370
	280	128	128	1 270 000	2 200 000	290 000	2 550	1 250	28,9	32036-X-XL-DF-A330-380
	320	172	182	2 040 000	3 300 000	425 000	2 270	1 020	62,3	32236-XL-DF-A330-380
	320	172	182	2 040 000	3 300 000	425 000	2 270	1 020	62,3	32236-XL-DF-A380-430
	320	172	182	2 040 000	3 300 000	425 000	2 270	1 020	62,3	32236-XL-DF-A385-445
	320	172	182	2 040 000	3 300 000	425 000	2 270	1 020	62,3	32236-XL-DF-A430-480
190	290	128	128	1 280 000	2 250 000	295 000	2 460	1 180	30,1	32038-X-XL-DF-A120-150
	290	128	128	1 280 000	2 250 000	295 000	2 460	1 180	30,1	32038-X-XL-DF-A200-250
	290	128	128	1 280 000	2 250 000	295 000	2 460	1 180	30,1	32038-X-XL-DF-A300-350
	290	128	128	1 280 000	2 250 000	295 000	2 460	1 180	30,1	32038-X-XL-DF-A350-400
	290	128	128	1 280 000	2 250 000	295 000	2 460	1 180	30,1	32038-X-XL-DF-A370-420
	290	128	128	1 280 000	2 250 000	295 000	2 460	1 180	30,1	32038-X-XL-DF-A580-630
200	360	196	208	2 700 000	4 150 000	510 000	2 030	890	88,2	32240-XL-DF-A350-400
	360	196	208	2 700 000	4 150 000	510 000	2 030	890	88,2	32240-XL-DF-A400-450
	360	196	208	2 700 000	4 150 000	510 000	2 030	890	88,2	32240-XL-DF-A500-550
240	360	152	152	1 820 000	3 350 000	415 000	1 950	870	53,5	32048-X-XL-DF-A300-350
	360	152	152	1 820 000	3 350 000	415 000	1 950	870	53,5	32048-X-XL-DF-A400-450
	360	152	152	1 820 000	3 350 000	415 000	1 950	870	53,5	32048-X-XL-DF-A450-500
	360	152	152	1 820 000	3 350 000	415 000	1 950	870	53,5	32048-X-XL-DF-A700-750
	440	240	254	3 750 000	6 200 000	730 000	1 630	660	166	32248-XL-DF-A350-400
	440	240	254	3 750 000	6 200 000	730 000	1 630	660	166	32248-XL-DF-A450-500
260	480	260	274	4 550 000	7 600 000	860 000	1 480	560	215	32252-XL-DF-A500-550
	480	260	274	4 550 000	7 600 000	860 000	1 480	560	215	32252-XL-DF-A550-600

medias ► <https://www.schaeffler.de/std/1F13>



Dimensions			Mounting dimensions					Calculation factors			
d	r ₃ , r ₄	A	d _a	D _a	D _a	C _a	r _b	e	Y ₁	Y ₂	Y ₀
	min.		max.	min.	max.	min.	max.				
150	2,5	24	164	200	213	8	2,5	0,46	1,47	2,19	1,44
	2,5	24	164	200	213	8	2,5	0,46	1,47	2,19	1,44
	2,5	26	164	200	213	8	2,5	0,36	1,85	2,76	1,81
170	4	40	196	259	292	10	4	0,44	1,55	2,31	1,52
	4	40	196	259	292	10	4	0,44	1,55	2,31	1,52
	4	40	196	259	292	10	4	0,44	1,55	2,31	1,52
180	2,5	32	199	247	268	10	2,5	0,42	1,6	2,38	1,56
	2,5	32	199	247	268	10	2,5	0,42	1,6	2,38	1,56
	2,5	32	199	247	268	10	2,5	0,42	1,6	2,38	1,56
	4	40	204	267	302	10	4	0,45	1,5	2,23	1,47
	4	40	204	267	302	10	4	0,45	1,5	2,23	1,47
	4	40	204	267	302	10	4	0,45	1,5	2,23	1,47
	4	40	204	267	302	10	4	0,45	1,5	2,23	1,47
190	2,5	32	209	257	278	10	2,5	0,44	1,53	2,27	1,49
	2,5	32	209	257	278	10	2,5	0,44	1,53	2,27	1,49
	2,5	32	209	257	278	10	2,5	0,44	1,53	2,27	1,49
	2,5	32	209	257	278	10	2,5	0,44	1,53	2,27	1,49
	2,5	32	209	257	278	10	2,5	0,44	1,53	2,27	1,49
	2,5	32	209	257	278	10	2,5	0,44	1,53	2,27	1,49
200	4	44	226	302	342	11	4	0,41	1,66	2,47	1,62
	4	44	226	302	342	11	4	0,41	1,66	2,47	1,62
	4	44	226	302	342	11	4	0,41	1,66	2,47	1,62
240	3	38	261	318	346	12	3	0,46	1,47	2,19	1,44
	3	38	261	318	346	12	3	0,46	1,47	2,19	1,44
	3	38	261	318	346	12	3	0,46	1,47	2,19	1,44
	3	38	261	318	346	12	3	0,46	1,47	2,19	1,44
	4	54	286	372	422	14	4	0,43	1,55	2,31	1,52
	4	54	286	372	422	14	4	0,43	1,55	2,31	1,52
260	5	62	306	401	458	14	5	0,43	1,57	2,34	1,53
	5	62	306	401	458	14	5	0,43	1,57	2,34	1,53





Integral tapered roller bearings

Sealed on one side

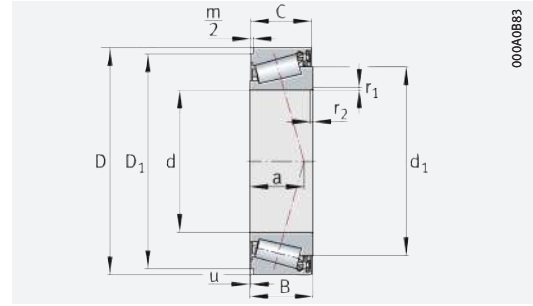

00040883

d = 30 – 80 mm

Main dimensions				Basic load ratings		Fatigue limit load C_{ur} N	Limiting speed n_G grease min^{-1}	Load carrying capacity $F_{BR}^{2)}$ N	Max. axial assembly clamping force Bearing pair N	Mass Bearing ¹⁾ m ≈ kg	Designation	
d	D	B	C	dyn. C_r N	stat. C_{0r} N						Bearing pair	Bearing
30	55	19	18,5	38 500	46 500	5 300	6 100	15 700	7 700	0,19	JK0S030	BR55
40	68	21	20,5	53 000	71 000	8 300	4 950	12 900	10 600	0,3	JK0S040³⁾	BR68
50	80	22	21,5	64 000	93 000	11 200	4 050	31 400	12 800	0,41	JK0S050	BR80
60	95	26	25	82 000	123 000	15 200	3 350	59 300	16 400	0,67	JK0S060	BR95
70	110	27	26,5	104 000	159 000	20 100	2 900	49 000	20 800	0,93	JK0S070-A	BR110
80	125	30	29,5	137 000	211 000	26 000	2 550	40 200	27 400	1,32	JK0S080-A	BR125

medias ► <https://www.schaeffler.de/std/1F14>

Other sizes and designs are also available; please contact us.

Ordering note

FAG integral tapered roller bearings are interchangeable with each other. When ordering, please always state the number of single bearings, not the number of bearing pairs. The snap ring must be ordered separately, for example

2 tapered roller bearings JK0S080-A
1 snap ring BR125

1) Ungreased.

2) For snap ring connection located against a sharp edge.

3) Also available with 95% grease filling; designation: JK0S040-J14.

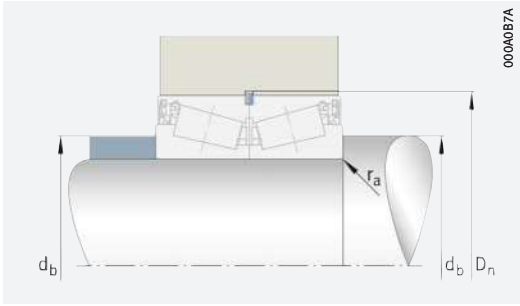

Mounting dimensions

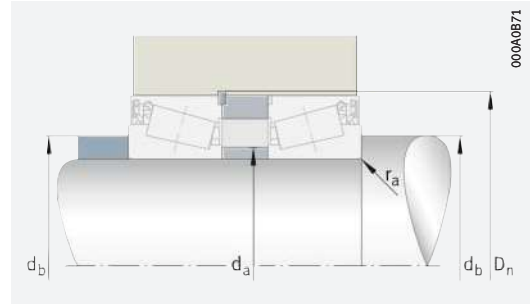

Mounting dimensions

Dimensions								Mounting dimensions					Calculation factors		
								Shaft			Slot				
d	r ₁ , r ₂	D ₁	m/2	a	u	Δ _u	d ₁	d _a	d _b	r _a	D _n	Δ _{Dn}	e	Y	Y ₀
	min.			≈		Devi- ations	≈	max.	min.	max.	Nominal dimension	Devi- ations			
30	1	51,4	0,75	15	0,02	+0,05 0	43,6	35	36	1	56,5	+0,19 0	0,43	1,4	0,77
40	1	64,4	0,75	16	0,03	+0,05 0	53,8	46	46	1	69,5	+0,19 0	0,37	1,6	0,88
50	1	75,7	1	19	0,02	+0,05 0	66,4	56	56	1	81,8	+0,22 0	0,42	1,43	0,79
60	1,5	89,3	1,25	23	0,03	+0,05 0	79,5	67	67	1,5	97	+0,22 0	0,43	1,4	0,77
70	1,5	104,8	1,25	25	0,03	+0,05 0	91,5	78	77	1,5	112,3	+0,22 0	0,43	1,38	0,76
80	1,5	119,8	1,25	28	0,03	+0,05 0	104,2	89	87	1,5	127,3	+0,25 0	0,42	1,42	0,78



Barrel roller bearings







Matrix for bearing preselection 641

1 Barrel roller bearings 642

- 1.1 Bearing design 642
- 1.2 Load carrying capacity 643
- 1.3 Compensation
of angular misalignments 644
- 1.4 Lubrication 644
- 1.5 Sealing 644
- 1.6 Speeds 644



1.7	Noise	644	1.17	Mounting and dismounting	652
1.8	Temperature range	645	1.18	Legal notice regarding data freshness	653
1.9	Cages	645	1.19	Further information	653
1.10	Internal clearance	645	Product tables	654	
1.11	Dimensions, tolerances	646	 Barrel roller bearings		
1.12	Suffixes	647	 with cylindrical or tapered bore	654	
1.13	Structure of bearing designation	647	 Barrel roller bearings		
1.14	Dimensioning	648	 with adapter sleeve	660	
1.15	Minimum load	648			
1.16	Design of bearing arrangements	649			

































Matrix for bearing preselection

The matrix gives an overview of the types and design features of barrel roller bearings.

It can be used to make a preliminary assessment of whether a bearing is fundamentally suitable for the envisaged application.

The additional information provided in the product chapter (see column "detailed information") and in the Technical principles must, however, be observed in selection of the bearing.

Design features and suitability			Barrel roller bearings		
+++ extremely suitable ++ highly suitable + suitable (+) suitable with restrictions - not suitable/not applicable available ✓ available			cylindrical or tapered bore 	with adapter sleeve 	detailed information  642
Load carrying capacity	radial		+++	+++	➤ 643 1.2
	axial, one direction		+	+	➤ 643 1.2
	axial, both directions		+	+	➤ 643 1.2
	moments		-	-	
Compensation of angular misalignments	static		+++	+++	➤ 644 1.3
	dynamic		+	+	➤ 644 1.3
Bearing design	cylindrical bore		✓	✓	➤ 642 1.1
	tapered bore		✓	-	➤ 642 1.1
	separable		-	-	➤ 652 1.17
Lubrication	greased		-	-	➤ 644 1.4
Sealing	open		✓	✓	➤ 644 1.5
	non-contact		-	-	
	contact		-	-	
Operating temperature in °C		from to 	-30 +150 ¹⁾	-30 +150 ¹⁾	➤ 645 1.8
Suitability for	high speeds		+	+	➤ 64
	high running accuracy		(+)	(+)	➤ 646 1.11 ➤ 114
	low-noise running		(+)	(+)	➤ 644 1.7 ➤ 27
	high rigidity		++	++	➤ 54
	reduced friction		+	+	➤ 56
	length compensation within bearing		-	-	
	non-locating bearing arrangement		+	+	➤ 139
	locating bearing arrangement		+	+	➤ 139
X-life bearings		X-life 	-	-	
Bearing bore ²⁾ d in mm		from to 	20 260 ³⁾	20 140 ³⁾	➤ 654
Product tables		from page 	654	660	

1) Data valid for bearings with brass cages, D ≤ 120 mm
 2) For bearings with adapter sleeve: inside diameter of adapter sleeve
 3) Larger catalogue bearings
 ➤ GL 1



1 Barrel roller bearings



Barrel roller bearings are suitable:

- for compensating angular misalignments where there is skewing between the outer and inner ring ➤644|1.3
- where high radial shock type loads occur, as a result of the line contact ➤643|1.2
- where angular misalignments and high radial loads occur, but speed is not a priority ➤642|1.

For an overview of other product-specific features, see the Matrix for bearing preselection ➤641.

1
Barrel roller bearing:
comparison of load carrying
capacity with
self-aligning ball bearing,
compensation of misalignments

F_r = radial load
 C_r = radial basic dynamic load
rating

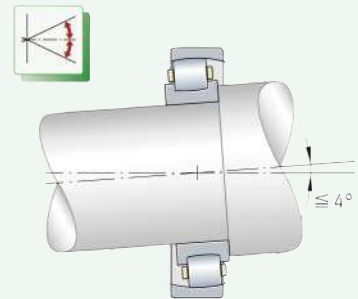
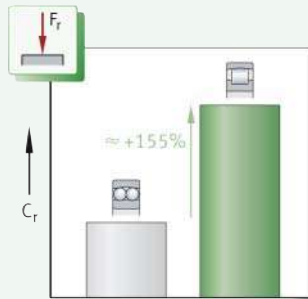

1.1 Bearing design

Design variants

Barrel roller bearings are available as:

- bearings of basic design ➤643|2
- bearings with adapter sleeve ➤643|3.

Bearings of basic design

The outer ring has a curved raceway

Barrel roller bearings are single row, self-retaining radial roller bearings, which are part of the group of self-aligning bearings. The outer ring has a concave raceway. As a result, the bearings permit the compensation of static and dynamic angular misalignments (skewing between the inner and outer ring) within certain limits ➤644|1.3. The inner ring has a formed raceway for the rolling elements and two rigid ribs. The rollers are barrel-shaped and are guided between the inner ring ribs. Their outside surface line closely follows the raceway profile of the outer and inner ring. Solid cages made from polyamide PA66 or brass are used ➤645|2.

The bore is cylindrical or tapered

Barrel roller bearings of basic design are available with a cylindrical or tapered bore, as a function of the bore diameter d ➤643|2.



Bearings with a tapered bore have a bore taper of 1:12 and the suffix K ➤647|5.

2 Barrel roller bearings of basic design

F_r = radial load
 F_a = axial load

- ① Barrel roller bearing with cylindrical bore
- ② Barrel roller bearing with tapered bore, bore taper 1:12

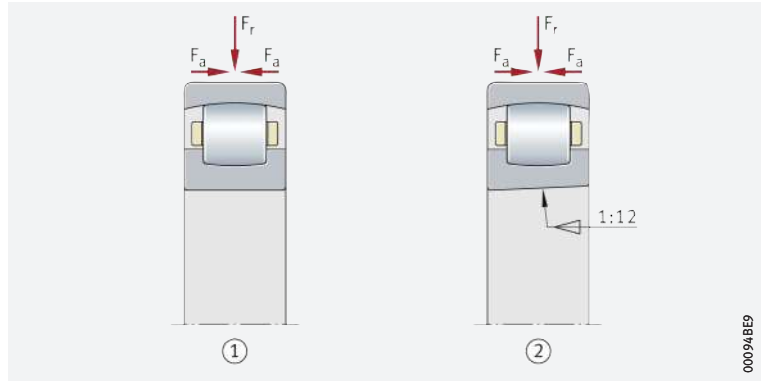

00094BE9

Ready-to-fit bearing mounting kits facilitate the ordering and mounting of barrel roller bearings

Bearings with adapter sleeve

Complete bearing mounting kits comprising the bearing of basic design, slotted adapter sleeve, tab washer and locknut, are also available for use in the location of barrel roller bearings with a tapered bore on a cylindrical shaft journal (series 202...-K + H, 203...-K + H) ▶643| 3. Adapter sleeves allow bearings to be located on smooth and stepped shafts. The adapter sleeves must also be stated when placing the order. Ordering example ▶647| 5.

3 Barrel roller bearing with adapter sleeve

F_r = radial load
 F_a = axial load

- ① Barrel roller bearing with tapered bore
- ② Adapter sleeve
- ③ Locknut
- ④ Tab washer

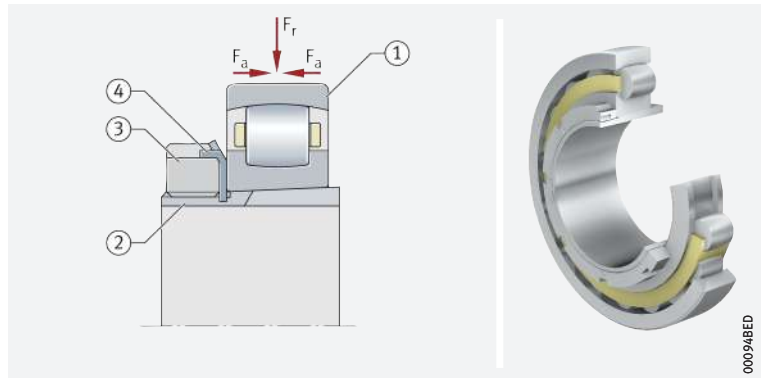

00094BED

1.2 Load carrying capacity

Suitable for high radial loads

The rolling elements are in line contact with the raceways. As a result, barrel roller bearings have a very high radial load carrying capacity ▶643| 2. In contrast, they have only a low axial load carrying capacity.

Axial load carrying capacity of bearings with adapter sleeve



Where bearings with adapter sleeves are located on a smooth shaft without a fixed stop (e.g. rigid shoulder), their axial load carrying capacity is dependent on the friction between the shaft and the sleeve.



If there is any uncertainty regarding the axial load carrying capacity of the adapter sleeve location method, please consult Schaeffler.

1.3 Compensation of angular misalignments

☞ *Barrel roller bearings compensate dynamic and static angular misalignments*

Due to the concave rolling element raceway in the outer ring, barrel roller bearings are capable of angular adjustment ► 642 | 1.1. As a result, they permit skewing between the outer and inner ring within certain limits, without causing damage to the bearings, and can thus compensate misalignments, shaft deflections and housing deformations.

Permissible adjustment angle

☞ *With a rotating inner ring, barrel roller bearings can swivel up to 4° from their central position*

The magnitude of alignment and angular defects may only be so large when the bearings are mounted that the contact surfaces of the rolling elements under load still lie within the width of the raceway. Under normal operating conditions and with a rotating inner ring, barrel roller bearings can swivel by up to 4° from their central position. The extent to which this value can be used for skewing between the inner and outer ring is, however, essentially dependent on the design of the bearing arrangement.



If the outer ring rotates or the inner ring undergoes tumbling motion, the angular adjustment facility is smaller. In such cases, please consult Schaeffler.

1.4 Lubrication

☞ *Oil or grease lubrication*

The bearings are not greased. They must be lubricated with oil or grease and can be lubricated from the end faces.

☞ *Compatibility with plastic cages*

When using bearings with plastic cages, compatibility between the lubricant and the cage material must be ensured if synthetic oils, lubricating greases with a synthetic oil base or lubricants containing a high proportion of EP additives are used.

☞ *Observe oil change intervals*

Aged oil and additives in the oil can impair the operating life of plastics at high temperatures. As a result, stipulated oil change intervals must be strictly observed.

1.5 Sealing

☞ *The bearings are open; provide seals in the adjacent construction*

Barrel roller bearings are supplied without seals. As a result, sealing of the bearing position must be carried out in the adjacent construction. The sealing system should reliably prevent:

- moisture and contaminants from entering the bearing
- the egress of lubricant from the bearing position.

1.6 Speeds



The product tables give the limiting speed n_G . This is the kinematically permissible speed of a bearing. Even under favourable mounting and operating conditions, this value should not be exceeded without prior consultation with Schaeffler ► 64.

1.7 Noise

Schaeffler Noise Index

The Schaeffler Noise Index (SGI) is not yet available for this bearing type ► 69. The data for these bearing series will be introduced and updated in stages.

Further information:

- **medias** ► <https://medias.schaeffler.com>.

1.8 Temperature range

Limiting values

The operating temperature of the bearings is limited by:

- the dimensional stability of the bearing rings and rolling elements
- the cage
- the lubricant.

Possible operating temperatures of barrel roller bearings ▶ 645 | 1.

Permissible temperature ranges



Operating temperature	Barrel roller bearings	
	with brass cage	with polyamide cage PA66
	-30 °C to +150 °C, for D > 120 mm up to +200 °C	-30 °C to +120 °C



In the event of anticipated temperatures which lie outside the stated values, please contact Schaeffler.

1.9 Cages

Standard cages for barrel roller bearings ▶ 645 | 2.

Cage, cage suffix, bore code



Bearing series	Solid cage made from polyamide PA66	Solid brass cage
	TVP	MB
	Bore code	
202	up to 16	from 17
203	up to 12	from 13



For high continuous temperatures and applications with difficult operating conditions, bearings with brass cages should be used. If there is any uncertainty regarding cage suitability, please consult Schaeffler.

1.10 Internal clearance

The standard is CN

Radial internal clearance – bearings with cylindrical bore

Barrel roller bearings with cylindrical bore are manufactured as standard with radial internal clearance CN (normal) ▶ 645 | 3. CN is not stated in the designation.



Certain sizes are also available by agreement with the smaller internal clearance C2 and with the larger internal clearance C3 and C4.

Values for radial internal clearance ▶ 645 | 3. These are valid for bearings which are free from load and measurement forces (without elastic deformation).

Radial internal clearance of barrel roller bearings with cylindrical bore



Nominal bore diameter d mm		Radial internal clearance							
		C2		CN		C3		C4	
		μm		μm		μm		μm	
over	incl.	min.	max.	min.	max.	min.	max.	min.	max.
–	30	2	9	9	17	17	28	28	40
30	40	3	10	10	20	20	30	30	45
40	50	3	13	13	23	23	35	35	50
50	65	4	15	15	27	27	40	40	55
65	80	5	20	20	35	35	55	55	75
80	100	7	25	25	45	45	65	65	90

continued ▼

 **3**
Radial internal clearance
of barrel roller bearings
with cylindrical bore

Nominal bore diameter		Radial internal clearance							
d		C2 (Group 2)		CN (Group N)		C3 (Group 3)		C4 (Group 4)	
mm		µm		µm		µm		µm	
over	incl.	min.	max.	min.	max.	min.	max.	min.	max.
100	120	10	30	30	50	50	70	70	95
120	140	15	35	35	55	55	80	80	110
140	160	20	40	40	65	65	95	95	125
160	180	25	45	45	70	70	100	100	130
180	225	30	50	50	75	75	105	105	135
225	250	35	55	55	80	80	110	110	140
250	280	40	60	60	85	85	115	115	145

continued ▲

Radial internal clearance – bearings with tapered bore

 C3 is normally used

Barrel roller bearings with tapered bore are normally manufactured with the larger radial internal clearance C3 ▶ 646 | .



Certain sizes are also available by agreement with the smaller internal clearance C2, with internal clearance CN (normal) and with the larger internal clearance C4.

Values for radial internal clearance ▶ 646 |  4. These are valid for bearings which are free from load and measurement forces (without elastic deformation).

 **4**
Radial internal clearance
of barrel roller bearings
with tapered bore

Nominal bore diameter		Radial internal clearance							
d		C2		CN		C3		C4	
mm		µm		µm		µm		µm	
over	incl.	min.	max.	min.	max.	min.	max.	min.	max.
–	30	9	17	17	28	28	40	40	55
30	40	10	20	20	30	30	45	45	60
40	50	13	23	23	35	35	50	50	65
50	65	15	27	27	40	40	55	55	75
65	80	20	35	35	55	55	75	75	95
80	100	25	45	45	65	65	90	90	120
100	120	30	50	50	70	70	95	95	125
120	140	35	55	55	80	80	110	110	140
140	160	40	65	65	95	95	125	125	155
160	180	45	70	70	100	100	130	130	160
180	225	50	75	75	105	105	135	135	165
225	250	55	80	80	110	110	140	140	170
250	280	60	85	85	115	115	145	145	175

1.11 Dimensions, tolerances

Dimension standards



The main dimensions of barrel roller bearings correspond to DIN 635-1:2010. Nominal dimensions of barrel roller bearings ▶ 654 | .

Chamfer dimensions



The limiting dimensions for chamfer dimensions correspond to DIN 620-6:2004. Overview and limiting values ▶ 135 | 7.11. Nominal value of chamfer dimension ▶ 654 | .

Tolerances



The tolerances for the dimensional and running accuracy of barrel roller bearings correspond to tolerance class Normal in accordance with ISO 492:2014. Tolerance values in accordance with ISO 492 ▶ 122 | 8.

1.12 Suffixes

5 Suffixes and corresponding descriptions

For a description of the suffixes used in this chapter ▶ 647 | 5 and **medias** interchange ▶ <https://www.schaeffler.de/std/1D52>.

Suffix	Description of suffix	
C2	Radial internal clearance C2 (smaller than normal)	Special design, available by agreement
C3	Radial internal clearance C3 (larger than normal)	Normally used for bearings with tapered bore, available by agreement for bearings with cylindrical bore
C4	Radial internal clearance C4 (larger than C3)	Special design, available by agreement
CN	Radial internal clearance CN (normal)	Standard for bearings with cylindrical bore, available by agreement for bearings with tapered bore
K	Tapered bore, taper 1:12	Standard
MB	Solid brass cage, guided on inner ring	Standard, cage material dependent on bore code
TVP	Solid cage made from glass fibre reinforced polyamide PA66	

1.13 Structure of bearing designation

Examples of composition of bearing designation

The designation of bearings follows a set model. Examples ▶ 647 | 4 and ▶ 647 | 5. The composition of designations is subject to DIN 623-1 ▶ 102 | 10.

4 Barrel roller bearing with cylindrical bore: designation structure



5 Barrel roller bearing with tapered bore and adapter sleeve: designation structure

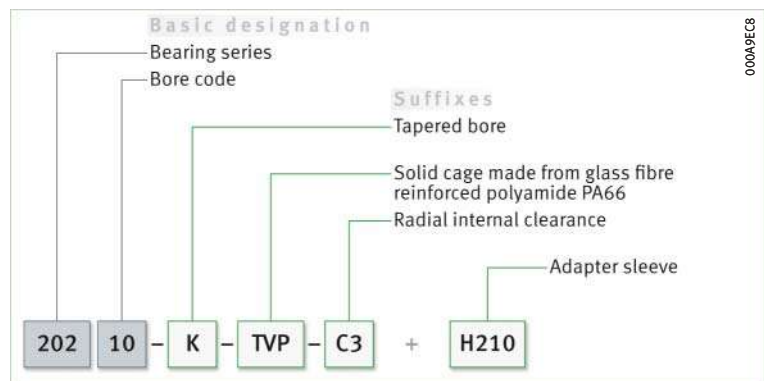

1.14 Dimensioning

$P = F_r$ under purely radial load of constant magnitude and direction

P is a substitute force for combined load and various load cases

Equivalent dynamic bearing load

The basic rating life equation $L = (C_r/P)^P$ used in the dimensioning of bearings under dynamic load assumes a load of constant magnitude and direction. In radial bearings, this is a purely radial load F_r . If this condition is met, the bearing load F_r is used in the rating life equation for P ($P = F_r$). If this condition is not met, a constant radial force must first be determined for the rating life calculation that (in relation to the rating life) represents an equivalent load. This force is known as the equivalent dynamic bearing load P .

To calculate P for barrel roller bearings under dynamic load ▶ 648 | f1 1.

f1 1
Equivalent dynamic load

$$P = F_r + 9,5 \cdot F_a$$

Legend

P	N	Equivalent dynamic bearing load
F_r	N	Radial load
F_a	N	Axial load.

Equivalent static bearing load

For barrel roller bearings subjected to static load ▶ 648 | f1 2.

f1 2
Equivalent static load

$$P_0 = F_{0r} + 5 \cdot F_{0a}$$

Legend

P_0	N	Equivalent static bearing load
F_{0r}, F_{0a}	N	Largest radial or axial load present (maximum load).

Static load safety factor

$$S_0 = C_0/P_0$$

In addition to the basic rating life $L (L_{10h})$, it is also always necessary to check the static load safety factor S_0 ▶ 648 | f1 3.

f1 3
Static load safety factor

$$S_0 = \frac{C_0}{P_0}$$

Legend

S_0	-	Static load safety factor
C_0	N	Basic static load rating
P_0	N	Equivalent static bearing load.

1.15 Minimum load

In order to prevent damage due to slippage, a minimum radial load of $P > C_{0r}/60$ is required

In order that no slippage occurs between the contact partners, the barrel roller bearings must be constantly subjected to a sufficiently high load. Based on experience, a minimum radial load of the order of $P > C_{0r}/60$ is thus necessary. In most cases, however, the radial load is already higher than the requisite minimum load due to the weight of the supported parts and the external forces.



If the minimum radial load is lower than indicated above, please consult Schaeffler.

1.16 Design of bearing arrangements

Support bearing rings over their entire circumference and width

In order to allow full utilisation of the load carrying capacity of the bearings and achieve the requisite rating life, the bearing rings must be rigidly and uniformly supported by means of contact surfaces over their entire circumference and over the entire width of the raceway. Support can be provided by means of a cylindrical or tapered seating surface ▶650| 6 to ▶650| 8. The seating and contact surfaces should not be interrupted by grooves, holes or other recesses. The accuracy of mating parts must meet specific requirements ▶651| 6 to ▶651| 8.

Radial location – fit recommendations for bearings with cylindrical bore

For secure radial location, tight fits are necessary

In addition to supporting the rings adequately, the bearings must also be securely located in a radial direction, to prevent creep of the bearing rings on the mating parts under load. This is generally achieved by means of tight fits between the bearing rings and the mating parts. If the rings are not secured adequately or correctly, this can cause severe damage to the bearings and adjacent machine parts. Influencing factors, such as the conditions of rotation, magnitude of the load, internal clearance, temperature conditions, design of the mating parts and the mounting and dismounting options must be taken into consideration in the selection of fits.



If shock type loads occur, tight fits (transition fit or interference fit) are required to prevent the rings from coming loose at any point. Clearance, transition or interference fits ▶150| 6 and ▶158| 7.



The following information provided in Technical principles must be taken into consideration in the design of bearing arrangements:

- conditions of rotation ▶145
- tolerance classes for cylindrical shaft seats (radial bearings) ▶147| 2
- shaft fits ▶150| 6
- tolerance classes for bearing seats in housings (radial bearings) ▶148| 4
- housing fits ▶158| 7
- shaft tolerances for adapter sleeves and withdrawal sleeves ▶166| 8.



The bearings must also be securely located in an axial direction

Axial location – location methods for bearings with cylindrical bore

As a tight fit alone is not normally sufficient to also locate the bearing rings securely on the shaft and in the housing bore in an axial direction, this must usually be achieved by means of an additional axial location or retention method. The axial location of the bearing rings must be matched to the type of bearing arrangement. Shaft and housing shoulders, housing covers, nuts, spacer rings, retaining rings, adapter and withdrawal sleeves etc., are fundamentally suitable.

Location by means of locknut and tab washer

Location of bearings with tapered bore

If a bearing with a tapered bore is mounted directly on a tapered journal, the bearing can be axially located with ease using a locknut and tab washer ▶ 650 | 6.



6
Barrel roller bearing with tapered bore, mounted directly on the tapered shaft journal

- ① Tapered journal with fixing thread
- ② Locknut
- ③ Tab washer

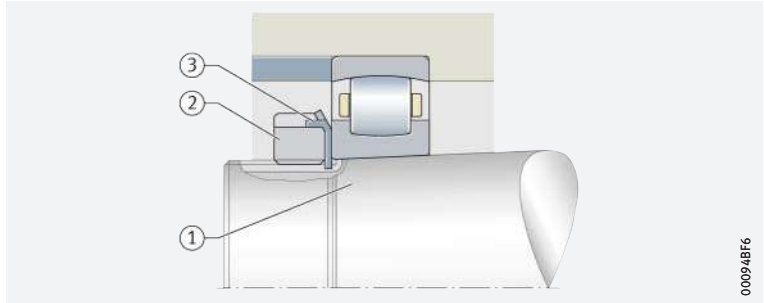

00094BF6

Mounting can be carried out quickly and reliably by means of wrench sets from Schaeffler

Location of bearings by means of adapter sleeve

Barrel roller bearings with a tapered bore can be located easily and with operational reliability on smooth or stepped shafts by means of an adapter sleeve ▶ 650 | 7. The adapter sleeves do not need to be secured on the shaft by any additional means. The bearings can be positioned at any point on smooth shafts. Axial load carrying capacity of bearing arrangements by means of adapter sleeve connection ▶ 643 | 1.2.



7
Barrel roller bearing with adapter sleeve, located on smooth shaft

- ① Adapter sleeve
- ② Locknut
- ③ Tab washer

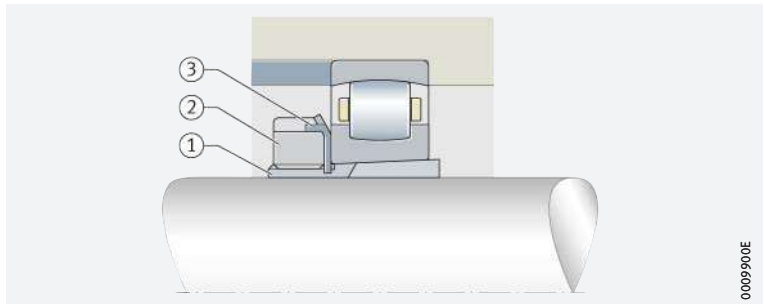

0009900E

Location by means of adapter sleeve, axial abutment by means of a support ring

If very high axial forces are present, a support ring can also be used to provide axial abutment ▶ 650 | 8. In this instance, the mounting dimensions of the support ring B_a and d_b in the product tables must be observed ▶ 660 | 8.



8
Stepped shaft, axial abutment by means of a support ring

- ① Adapter sleeve
- ② Locknut
- ③ Tab washer
- ④ Support ring
- ⑤ Shaft shoulder

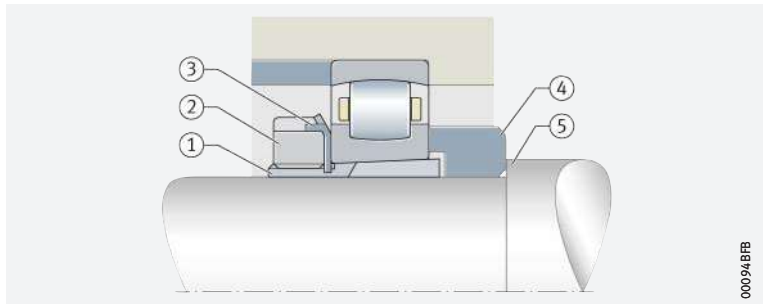

00094BFB

Dimensional, geometrical and running accuracy of cylindrical bearing seats

A minimum of IT6 should be provided for the shaft seat and a minimum of IT7 for the housing seat

The accuracy of the cylindrical bearing seat on the shaft and in the housing should correspond to the accuracy of the bearing used. For barrel roller bearings with the tolerance class Normal, the shaft seat should correspond to a minimum of standard tolerance grade IT6 and the housing seat to a minimum of IT7. Guide values for the geometrical and positional tolerances of bearing seating surfaces ▶ 651 | 6, tolerances t_1 to t_3 in accordance with ▶ 168 | 11. Numerical values for IT grades ▶ 651 | 7.

6
Guide values for the geometrical and positional tolerances of bearing seating surfaces

Bearing tolerance class		Bearing seating surface	Standard tolerance grades to ISO 286-1 (IT grades)			
to ISO 492	to DIN 620		Diameter tolerance	Roundness tolerance	Parallelism tolerance	Total axial runout tolerance of abutment shoulder
				t_1	t_2	t_3
Normal	PN (P0)	Shaft	IT6 (IT5)	Circumferential load IT4/2	Circumferential load IT4/2	IT4
				Point load IT5/2	Point load IT5/2	
		Housing	IT7 (IT6)	Circumferential load IT5/2	Circumferential load IT5/2	IT5
				Point load IT6/2	Point load IT6/2	

7
Numerical values for ISO standard tolerances (IT grades) to ISO 286-1:2010

IT grade	Nominal dimension in mm							
	over	18	30	50	80	120	180	250
	incl.	30	50	80	120	180	250	315
Values in μm								
IT4		6	7	8	10	12	14	16
IT5		9	11	13	15	18	20	23
IT6		13	16	19	22	25	29	32
IT7		21	25	30	35	40	46	52

Roughness of cylindrical bearing seating surfaces

Ra must not be too high

The roughness of the bearing seats must be matched to the tolerance class of the bearings. The mean roughness value Ra must not be too high, in order to maintain the interference loss within limits. The shafts must be ground, while the bores must be precision turned. Guide values as a function of the IT grade of bearing seating surfaces ▶ 651 | 8.

8
Roughness values for cylindrical bearing seating surfaces – guide values

Nominal diameter of the bearing seat d (D)		Recommended mean roughness value for ground bearing seats Ramax			
mm		μm			
		Diameter tolerance (IT grade)			
over	incl.	IT7	IT6	IT5	IT4
–	80	1,6	0,8	0,4	0,2
80	500	1,6	1,6	0,8	0,4

Tolerances for tapered bearing seats

Specifications for tapered bearing seats

For bearings located directly on a tapered shaft journal ▶ 650 | 6, the data are in accordance with ▶ 171 | 12.

The contact surfaces for the rings must be of sufficient height

Mounting dimensions for the contact surfaces of bearing rings

The mounting dimensions of the shaft and housing shoulders, and spacer rings etc., must ensure that the contact surfaces for the bearing rings are of sufficient height. However, they must also reliably prevent rotating parts of the bearing from grazing stationary parts. Proven mounting dimensions for the radii and diameters of the abutment shoulders are given in the product tables. These dimensions are limiting dimensions (maximum or minimum dimensions); the actual values should not be higher or lower than specified.

A large range of housings is available

Suitable bearing housings for barrel roller bearings

For economical, operationally reliable and easily interchangeable bearing arrangement units, the barrel roller bearings can also be combined with Schaeffler bearing housings ▶ 652 | 9. These easy-to-fit units fulfil all of the requirements for modern machine and plant designs with favourable maintenance-related characteristics.



Due to the large number of application areas, an extensive range of split plummer block housings and flanged housings is available for bearings with cylindrical and tapered bores. Detailed information on bearing housings can be found in publication GK 1 ▶ <https://www.schaeffler.de/std/1D54>. This book can be ordered from Schaeffler.

 Split plummer block housing with a barrel roller bearing

- ① Split plummer block housing SNV
- ② Barrel roller bearing

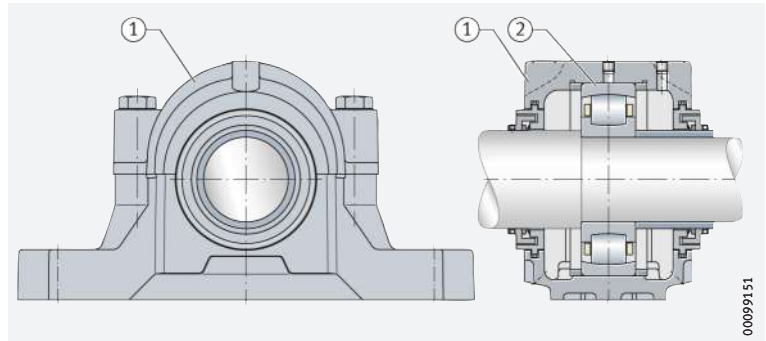

1.17 Mounting and dismounting



The mounting and dismounting options for barrel roller bearings, by thermal, hydraulic or mechanical methods, must be taken into consideration in the design of the bearing position.

Ensure that the bearings are not damaged during mounting

Barrel roller bearings are not separable. In the mounting of non-separable bearings, the mounting forces must always be applied to the bearing ring with a tight fit.

Suitable methods: measuring the reduction in radial internal clearance or axial drive-up distance

Bearings with tapered bore – methods for achieving a sufficiently tight fit

Bearings with a tapered bore are mounted with a tight fit on the shaft or adapter and withdrawal sleeve. The tight fit can be checked:

- by measuring the reduction in radial internal clearance or
- by measuring the axial drive-up distance of the inner ring on the tapered bearing seat.



The malfunction-free operation of barrel roller bearings presupposes that these have been mounted correctly. An insufficient operating clearance or inadequately tight fit on the shaft generally leads to bearing damage.



If there is any uncertainty regarding the practical application of both methods, Schaeffler must always be consulted.

👉 *Rolling bearings must be handled with great care*

Schaeffler Mounting Handbook

Rolling bearings are well-proven precision machine elements for the design of economical and reliable bearing arrangements, which offer high operational security. In order that these products can function correctly and achieve the envisaged operating life without detrimental effect, they must be handled with care.



The Schaeffler Mounting Handbook MH 1 gives comprehensive information about the correct storage, mounting, dismounting and maintenance of rotary rolling bearings ► <https://www.schaeffler.de/std/1D53>. It also provides information which should be observed by the designer, in relation to the mounting, dismounting and maintenance of bearings, in the original design of the bearing position. This book is available from Schaeffler on request.

1.18 Legal notice regarding data freshness

👉 *The further development of products may also result in technical changes to catalogue products*

Of central interest to Schaeffler is the further development and optimisation of its products and the satisfaction of its customers. In order that you, as the customer, can keep yourself optimally informed about the progress that is being made here and with regard to the current technical status of the products, we publish any product changes which differ from the printed version in our electronic product catalogue.



We therefore reserve the right to make changes to the data and illustrations in this catalogue. This catalogue reflects the status at the time of printing. More recent publications released by us (as printed or digital media) will automatically precede this catalogue if they involve the same subject. Therefore, please always use our electronic product catalogue to check whether more up-to-date information or modification notices exist for your desired product.

Link to electronic product catalogue



The following link will take you to the Schaeffler electronic product catalogue: ► <https://medias.schaeffler.com>.



1.19 Further information



In addition to the data in this chapter, the following chapters in Technical principles must also be observed in the design of bearing arrangements:

- Determining the bearing size ► 34
- Rigidity ► 54
- Friction and increases in temperature ► 56
- Speeds ► 64
- Bearing data ► 97
- Lubrication ► 70
- Sealing ► 182
- Design of bearing arrangements ► 139
- Mounting and dismounting ► 191.

Barrel roller bearings

With cylindrical or tapered bore

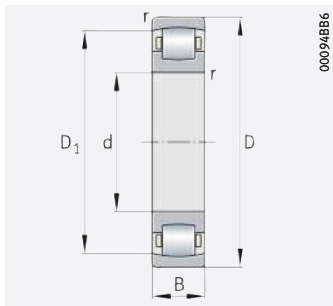

Cylindrical bore

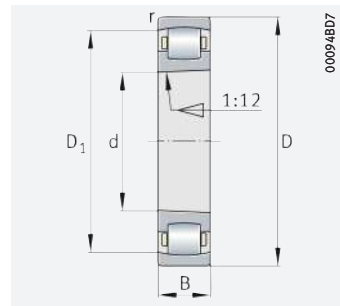

Tapered bore

d = 20 – 65 mm

Main dimensions			Basic load ratings		Fatigue limit load	Limiting speed	Mass	Designation
d	D	B	dyn. C_r N	stat. C_{0r} N	C_{ur} N	n_G min ⁻¹	m ≈ kg	▶ 647 1.12 ▶ 647 1.13
20	47	14	20 400	19 400	1 680	13 100	0,114	20204-TVP
	52	15	27 000	24 600	2 300	11 800	0,152	20304-TVP
25	52	15	24 100	24 900	2 190	11 500	0,132	20205-K-TVP-C3
	52	15	24 100	24 900	2 190	11 500	0,134	20205-TVP
	62	17	36 000	35 000	2 950	9 800	0,243	20305-TVP
30	62	16	28 000	28 500	2 850	10 800	0,203	20206-K-TVP-C3
	62	16	28 000	28 500	2 850	10 800	0,207	20206-TVP
	72	19	48 500	48 500	4 200	8 800	0,37	20306-TVP
35	72	17	41 000	43 000	4 900	9 700	0,296	20207-K-TVP-C3
	72	17	41 000	43 000	4 900	9 700	0,301	20207-TVP
	80	21	58 000	61 000	5 400	8 000	0,493	20307-TVP
40	80	18	49 500	53 000	5 000	8 700	0,38	20208-K-TVP-C3
	80	18	49 500	53 000	5 000	8 700	0,386	20208-TVP
	90	23	76 000	81 000	7 100	7 000	0,671	20308-TVP
45	85	19	52 000	58 000	5 900	8 400	0,433	20209-K-TVP-C3
	85	19	52 000	58 000	5 900	8 400	0,441	20209-TVP
	100	25	87 000	94 000	8 400	6 500	0,914	20309-TVP
50	90	20	59 000	69 000	7 000	7 700	0,489	20210-K-TVP-C3
	90	20	59 000	69 000	7 000	7 700	0,499	20210-TVP
	110	27	108 000	118 000	10 300	5 800	1,17	20310-TVP
55	100	21	74 000	85 000	8 700	7 100	0,642	20211-K-TVP-C3
	100	21	74 000	85 000	8 700	7 100	0,653	20211-TVP
	120	29	120 000	138 000	12 300	5 400	1,49	20311-K-TVP-C3
	120	29	120 000	138 000	12 300	5 400	1,53	20311-TVP
60	110	22	85 000	100 000	10 700	6 600	0,822	20212-K-TVP-C3
	110	22	85 000	100 000	10 700	6 600	0,836	20212-TVP
	130	31	147 000	171 000	15 000	4 950	1,89	20312-K-TVP-C3
	130	31	147 000	171 000	15 000	4 950	1,92	20312-TVP
65	120	23	94 000	117 000	12 400	6 000	1,07	20213-K-TVP-C3
	120	23	94 000	117 000	12 400	6 000	1,08	20213-TVP
	140	33	168 000	195 000	17 700	4 700	2,14	20313-K-MB-C3
	140	33	168 000	195 000	17 700	4 700	2,18	20313-MB

medias ▶ <https://www.schaeffler.de/std/1D88>

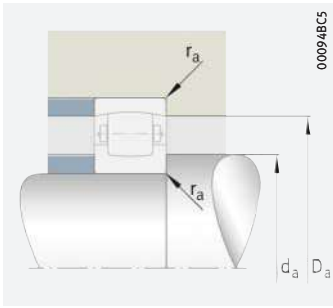

Mounting dimensions

Dimensions			Mounting dimensions		
d	r	D ₁	d _a	D _a	r _a
	min.	≈	min.	max.	max.
20	1	39	25,6	41,4	1
	1,1	43,5	27	45	1
25	1	43,9	30,6	46,4	1
	1	43,9	30,6	46,4	1
	1,1	51,9	32	55	1
30	1	53	35,6	56,4	1
	1	53	35,6	56,4	1
	1,1	60,7	37	65	1
35	1,1	62,3	42	65	1
	1,1	62,3	42	65	1
	1,5	67,4	44	71	1,5
40	1,1	70,1	47	73	1
	1,1	70,1	47	73	1
	1,5	76,8	49	81	1,5
45	1,1	74,6	52	78	1
	1,1	74,6	52	78	1
	1,5	85,2	54	91	1,5
50	1,1	79,5	57	83	1
	1,1	79,5	57	83	1
	2	94,4	61	99	2
55	1,5	89,2	64	91	1,5
	1,5	89,2	64	91	1,5
	2	101,7	66	109	2
	2	101,7	66	109	2
60	1,5	97,8	69	101	1,5
	1,5	97,8	69	101	1,5
	2,1	111,2	72	118	2,1
	2,1	111,2	72	118	2,1
65	1,5	105,1	74	111	1,5
	1,5	105,1	74	111	1,5
	2,1	120,6	77	128	2,1
	2,1	120,6	77	128	2,1





Barrel roller bearings

With cylindrical or tapered bore

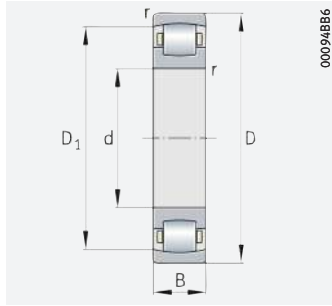

Cylindrical bore

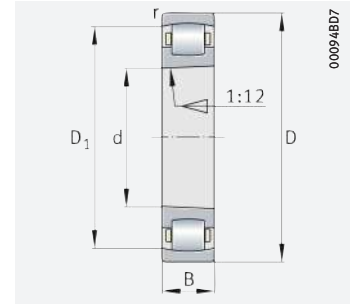

Tapered bore

d = 70 – 140 mm

Main dimensions			Basic load ratings		Fatigue limit load C_{ur} N	Limiting speed n_G min^{-1}	Mass m \approx kg	Designation ➤ 647 1.12 ➤ 647 1.13
d	D	B	dyn. C_r N	stat. C_{0r} N				
70	125	24	107 000	133 000	13 900	5 700	1,17	20214-TVP
	150	35	184 000	215 000	19 400	4 450	3,15	20314-MB
75	130	25	112 000	143 000	16 000	5 500	1,25	20215-K-TVP-C3
	130	25	112 000	143 000	16 000	5 500	1,28	20215-TVP
	160	37	216 000	255 000	22 200	4 100	3,76	20315-MB
80	140	26	126 000	163 000	15 400	5 200	1,56	20216-K-TVP-C3
	140	26	126 000	163 000	15 400	5 200	1,58	20216-TVP
	170	39	243 000	285 000	25 000	3 950	4,58	20316-MB
85	150	28	155 000	201 000	20 200	4 750	2,19	20217-K-MB-C3
	150	28	155 000	201 000	20 200	4 750	2,22	20217-MB
	180	41	270 000	320 000	28 500	3 750	5,25	20317-MB
90	160	30	174 000	220 000	21 900	4 550	2,68	20218-K-MB-C3
	160	30	174 000	220 000	21 900	4 550	2,72	20218-MB
	190	43	300 000	360 000	30 500	3 500	6,17	20318-K-MB-C3
	190	43	300 000	360 000	30 500	3 500	6,25	20318-MB
95	170	32	206 000	265 000	26 000	4 200	3,19	20219-MB
	200	45	330 000	400 000	33 500	3 400	7,29	20319-MB
100	180	34	225 000	290 000	28 000	4 000	3,9	20220-K-MB-C3
	180	34	225 000	290 000	28 000	4 000	3,96	20220-MB
	215	47	365 000	440 000	37 500	3 250	8,58	20320-K-MB-C3
	215	47	365 000	440 000	37 500	3 250	8,69	20320-MB
105	190	36	244 000	315 000	30 000	3 850	4,74	20221-MB
110	200	38	285 000	370 000	34 000	3 600	5,45	20222-K-MB-C3
	200	38	285 000	370 000	34 000	3 600	5,53	20222-MB
	240	50	405 000	480 000	44 500	3 000	11,6	20322-MB
120	215	40	305 000	415 000	37 500	3 350	6,51	20224-K-MB-C3
	215	40	305 000	415 000	37 500	3 350	6,6	20224-MB
	260	55	490 000	630 000	51 000	2 750	15,2	20324-MB
130	230	40	330 000	450 000	42 000	3 300	7,21	20226-K-MB-C3
	230	40	330 000	450 000	42 000	3 300	7,31	20226-MB
	280	58	560 000	720 000	58 000	2 600	18,4	20326-MB
140	250	42	395 000	540 000	49 500	3 050	8,98	20228-K-MB-C3
	250	42	395 000	540 000	49 500	3 050	9,09	20228-MB
	300	62	650 000	840 000	66 000	2 370	22,5	20328-MB

medias ➤ <https://www.schaeffler.de/std/1D89>

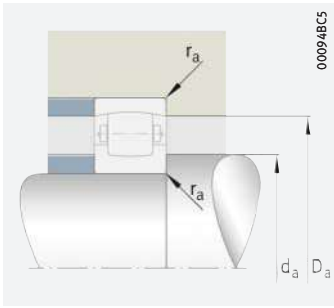

Mounting dimensions

Dimensions			Mounting dimensions		
d	r	D ₁	d _a	D _a	r _a
	min.	≈	min.	max.	max.
70	1,5	111	79	116	1,5
	2,1	128,7	82	138	2,1
75	1,5	115,9	84	121	1,5
	1,5	115,9	84	121	1,5
	2,1	138,1	87	148	2,1
80	2	124,5	91	129	2
	2	124,5	91	129	2
	2,1	147,5	92	158	2,1
85	2	133,9	96	139	2
	2	133,9	96	139	2
	3	156,9	99	166	2,5
90	2	143,8	101	149	2
	2	143,8	101	149	2
	3	165,1	104	176	2,5
	3	165,1	104	176	2,5
95	2,1	152,7	107	158	2,1
	3	174,5	109	186	2,5
100	2,1	160,8	112	168	2,1
	2,1	160,8	112	168	2,1
	3	186,6	114	201	2,5
	3	186,6	114	201	2,5
105	2,1	169,2	117	178	2,1
110	2,1	178,6	122	188	2,1
	2,1	178,6	122	188	2,1
	3	208,1	124	226	2,5
120	2,1	191,1	132	203	2,1
	2,1	191,1	132	203	2,1
	3	222,3	134	246	2,5
130	3	205,7	144	216	2,5
	3	205,7	144	216	2,5
	4	240,3	147	263	3
140	3	223,9	154	236	2,5
	3	223,9	154	236	2,5
	4	257,9	157	283	3





Barrel roller bearings

With cylindrical or tapered bore

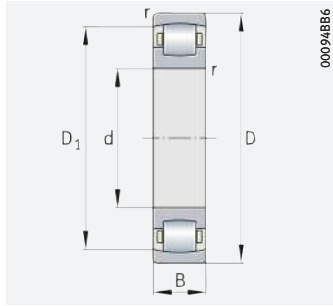

Cylindrical bore

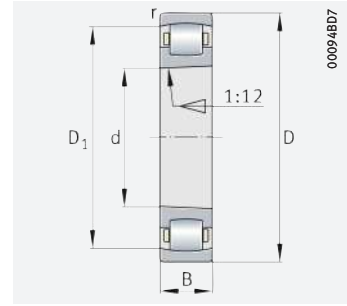

Tapered bore

d = 150 – 200 mm

Main dimensions			Basic load ratings		Fatigue limit load C_{ur} N	Limiting speed n_G min^{-1}	Mass m \approx kg	Designation ► 647 1.12 ► 647 1.13
d	D	B	dyn. C_r N	stat. C_{0r} N				
150	270	45	430 000	610 000	54 000	2 850	11,6	20230-K-MB-C3
	270	45	430 000	610 000	54 000	2 850	11,7	20230-MB
	320	65	720 000	950 000	74 000	2 250	26,9	20330-MB
160	290	48	500 000	720 000	63 000	2 650	14,4	20232-K-MB-C3
	290	48	500 000	720 000	63 000	2 650	14,5	20232-MB
170	310	52	570 000	830 000	70 000	2 460	17,9	20234-MB
180	320	52	590 000	850 000	73 000	2 420	18,4	20236-MB
190	340	55	650 000	950 000	80 000	2 290	22,5	20238-MB
200	360	58	730 000	1 080 000	90 000	2 180	26,7	20240-MB

medias ► <https://www.schaeffler.de/std/1D8A>

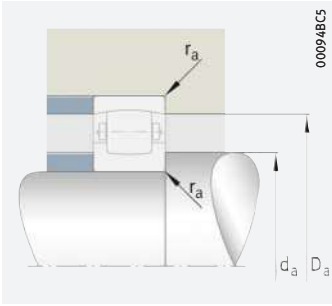

Mounting dimensions

Dimensions			Mounting dimensions		
d	r	D ₁	d _a	D _a	r _a
	min.	≈	min.	max.	max.
150	3	238,6	164	256	2,5
	3	238,6	164	256	2,5
	4	275,8	167	303	3
160	3	256,5	174	276	2,5
	3	256,5	174	276	2,5
170	4	273,1	187	293	3
180	4	284,3	197	303	3
190	4	301,2	207	323	3
200	4	319	217	343	3





Barrel roller bearings

With adapter sleeve

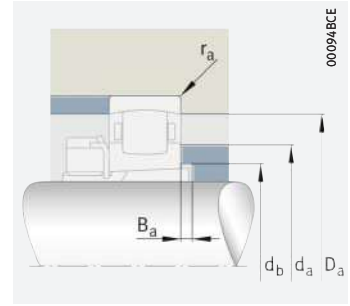
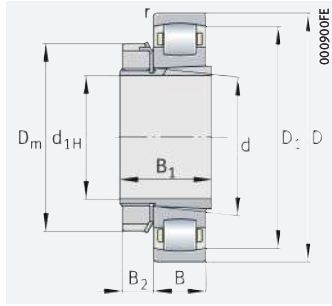

Mounting dimensions

$d_{1H} = 20 - 140 \text{ mm}$

Main dimensions				Basic load ratings		Fatigue limit load	Limiting speed	Mass m		Designation	
d_{1H}	d	D	B	dyn. C_r N	stat. C_{0r} N	C_{ur} N	n_G min ⁻¹	Bearing ≈ kg	Adapter sleeve ≈ kg	Bearing	Adapter sleeve
20	25	52	15	24 100	24 900	2 190	11 500	0,132	0,07	20205-K-TVP-C3	H205
25	30	62	16	28 000	28 500	2 850	10 800	0,203	0,1	20206-K-TVP-C3	H206
30	35	72	17	41 000	43 000	4 900	9 700	0,296	0,136	20207-K-TVP-C3	H207
35	40	80	18	49 500	53 000	5 000	8 700	0,38	0,177	20208-K-TVP-C3	H208
40	45	85	19	52 000	58 000	5 900	8 400	0,433	0,23	20209-K-TVP-C3	H209
45	50	90	20	59 000	69 000	7 000	7 700	0,489	0,276	20210-K-TVP-C3	H210
50	55	100	21	74 000	85 000	8 700	7 100	0,642	0,319	20211-K-TVP-C3	H211
	55	120	29	120 000	138 000	12 300	5 400	1,49	0,358	20311-K-TVP-C3	H311
55	60	110	22	85 000	100 000	10 700	6 600	0,822	0,35	20212-K-TVP-C3	H212
	60	130	31	147 000	171 000	15 000	4 950	1,89	0,401	20312-K-TVP-C3	H312
60	65	120	23	94 000	117 000	12 400	6 000	1,07	0,4	20213-K-TVP-C3	H213
	65	140	33	168 000	195 000	17 700	4 700	2,14	0,471	20313-K-MB-C3	H313
65	75	130	25	112 000	143 000	16 000	5 500	1,25	0,71	20215-K-TVP-C3	H215
70	80	140	26	126 000	163 000	15 400	5 200	1,56	0,89	20216-K-TVP-C3	H216
75	85	150	28	155 000	201 000	20 200	4 750	2,19	1,03	20217-K-MB-C3	H217
80	90	160	30	174 000	220 000	21 900	4 550	2,68	1,21	20218-K-MB-C3	H218
	90	190	43	300 000	360 000	30 500	3 500	6,17	1,41	20318-K-MB-C3	H318
90	100	180	34	225 000	290 000	28 000	4 000	3,9	1,52	20220-K-MB-C3	H220
	100	215	47	365 000	440 000	37 500	3 250	8,58	1,76	20320-K-MB-C3	H320
100	110	200	38	285 000	370 000	34 000	3 600	5,45	1,95	20222-K-MB-C3	H222
110	120	215	40	305 000	415 000	37 500	3 350	6,51	2,01	20224-K-MB-C3	H3024
115	130	230	40	330 000	450 000	42 000	3 300	7,21	2,96	20226-K-MB-C3	H3026
125	140	250	42	395 000	540 000	49 500	3 050	8,98	3,3	20228-K-MB-C3	H3028
135	150	270	45	430 000	610 000	54 000	2 850	11,6	4,02	20230-K-MB-C3	H3030
140	160	290	48	500 000	720 000	63 000	2 650	14,4	5,44	20232-K-MB-C3	H3032

medias ► <https://www.schaeffler.de/std/1D8B>



Dimensions						Mounting dimensions				
d_{1H}	r	D_1	D_m	B_1	B_2	d_a	D_a	d_b	B_a	r_a
	min.	≈	≈		≈	max.	max.	min.	min.	max.
20	1	43,9	25	26	8,25	33	46,4	28	6	1
25	1	53	45	27	8,25	39	56,4	33	5	1
30	1,1	62,3	52	29	9,25	45	65	38	5	1
35	1,1	70,1	58	31	10,25	51	73	43	5	1
40	1,1	74,6	65	33	11,25	56	78	48	5	1
45	1,1	79,5	70	35	12,25	61	83	53	5	1
50	1,5	89,2	75	37	12,5	68	91	60	6	1,5
	2	101,7	75	45	12,5	72	109	60	6	2
55	1,5	97,8	80	38	12,5	73	101	64	6	1,5
	2,1	111,2	80	47	12,5	78	118	65	5	2,1
60	1,5	105,1	85	40	13,5	80	111	70	5	1,5
	2,1	120,6	85	50	13,5	84	128	70	5	2,1
65	1,5	115,9	98	43	14,5	90	121	80	5	1,5
70	2	124,5	105	46	16,75	96	129	85	5	2
75	2	133,9	110	50	17,75	102	139	90	6	2
80	2	143,8	120	52	17,75	108	149	95	6	2
	3	165,1	120	65	17,75	113	176	96	6	2,5
90	2,1	160,8	130	58	19,75	120	168	106	7	2,1
	3	186,6	130	71	19,75	127	201	108	7	2,5
100	2,1	178,6	145	63	20,75	132	188	116	7	2,1
110	2,1	191,1	145	72	22	143	203	127	13	2,1
115	3	205,7	155	80	23	154	216	137	20	2,5
125	3	223,9	165	82	24	166	236	147	19	2,5
135	3	238,6	180	87	26	181	256	158	19	2,5
140	3	256,5	190	93	27,5	193	276	168	20	2,5



Spherical roller bearings



Matrix for bearing preselection 664

1 Spherical roller bearings **666**

1.1	Bearing design	666
1.2	Load carrying capacity	672
1.3	Compensation of angular misalignments	673
1.4	Lubrication	673
1.5	Sealing	674
1.6	Speeds	675
1.7	Noise	675
1.8	Temperature range	675
1.9	Cages	676

1.10	Internal clearance	678
1.11	Dimensions, tolerances	679
1.12	Suffixes	681
1.13	Structure of bearing designation	683
1.14	Dimensioning	684
1.15	Minimum load	685
1.16	Design of bearing arrangements	685
1.17	Mounting and dismounting	691
1.18	Legal notice regarding data freshness	695
1.19	Further information	695

Product tables	696
 Spherical roller bearings with cylindrical or tapered bore	696
Spherical roller bearings, sealed	752
Spherical roller bearings with adapter sleeve	756
Spherical roller bearings with withdrawal sleeve	770
Spherical roller bearings for vibratory machinery with cylindrical or tapered bore	788
Spherical roller bearings for vibratory machinery with adapter sleeve	792
Spherical roller bearings for vibratory machinery with withdrawal sleeve	794





Matrix for bearing preselection

The matrix gives an overview of the types and design features of spherical roller bearings.

It can be used to make a preliminary assessment of whether a bearing is fundamentally suitable for the envisaged application.

The additional information provided in the product chapter (see column "detailed information") and in the Technical principles must, however, be observed in addition to this overview in selection of the bearing.

Design features and suitability			Spherical roller bearings		
			cylindrical or tapered bore	sealed	detailed information
					666
+++ extremely suitable ++ highly suitable + suitable (+) suitable with restrictions - not suitable/not applicable ✓ available					
Load carrying capacity	radial		+++	+++	▶ 672 1.2
	axial, one direction		++	++	▶ 672 1.2
	axial, both directions		++	++	▶ 672 1.2
	moments		-	-	
Compensation of angular misalignments	static		+++	+++	▶ 673 1.3
	dynamic		+	+	▶ 673 1.3
Bearing design	cylindrical bore		✓	✓	▶ 666 1.1
	tapered bore		✓	✓ ⁴⁾	▶ 666 1.1
	separable		-	-	▶ 691 1.17
Lubrication	greased		-	✓	▶ 673 1.4
Sealing	open		✓	-	▶ 674 1.5
	non-contact		-	-	
	contact		-	✓	▶ 674 1.5
Operating temperature in °C		from to	-30 +200 ¹⁾	-30 +180 ²⁾	▶ 675 1.8
Suitability for	high speeds		+	(+)	▶ 675 1.6
	high running accuracy		+	+	▶ 679 1.11 ▶ 114
	low-noise running		(+)	+	▶ 27
	high rigidity		++	++	▶ 54
	reduced friction		+	+	▶ 56
	length compensation within bearing		-	-	
	non-locating bearing arrangement		+	+	▶ 139
locating bearing arrangement		++	++	▶ 139	
X-life bearings			✓	✓	▶ 671
Bearing bore ³⁾ d in mm		from to	20 1800	25 620	▶ 696
Product tables		from page	696	752	

1) Data valid for bearings with brass or sheet steel cages































2) Valid only for bearing series 240, 241. Series 222, 223: -40 °C to +100 °C

3) For bearings with adapter sleeve or withdrawal sleeve: inside diameter of adapter or withdrawal sleeve

4) Available by agreement

5) Larger catalogue bearings
▶ GL 1



Spherical roller bearings for vibratory machinery						
	with adapter sleeve	with withdrawal sleeve	cylindrical or tapered bore	with adapter sleeve	with withdrawal sleeve	detailed information
						 666
+++	+++	+++	+++	+++	+++	▶ 672 1.2 
++	++	++	++	++	++	▶ 672 1.2 
++	++	++	++	++	++	▶ 672 1.2 
-	-	-	-	-	-	
+++	+++	+++	+++	+++	+++	▶ 673 1.3 
+	+	+	+	+	+	▶ 673 1.3 
✓	✓	✓	✓	✓	✓	▶ 666 1.1 
-	-	✓	-	-	-	▶ 666 1.1 
-	-	-	-	-	-	▶ 691 1.17 
-	-	-	-	-	-	▶ 673 1.4 
✓	✓	✓	✓	✓	✓	▶ 674 1.5 
-	-	-	-	-	-	
-	-	-	-	-	-	
-30 +200 ¹⁾	-30 +200 ¹⁾	-30 +200 ¹⁾	-30 +200 ¹⁾	-30 +200 ¹⁾	-30 +200 ¹⁾	▶ 675 1.8 
+	+	+	+	+	+	▶ 675 1.6 
(+)	(+)	(+)	(+)	(+)	(+)	▶ 679 1.11 ▶ 114 
+	+	+	+	+	+	▶ 27 
++	++	++	++	++	++	▶ 54 
+	+	+	+	+	+	▶ 56 
-	-	-	-	-	-	
+	+	+	+	+	+	▶ 139 
++	++	++	++	++	++	▶ 139 
✓	✓	✓	✓	✓	✓	▶ 671 
20 850 ⁵⁾	35 850 ⁵⁾	40 220	35 200	35 200		▶ 756 
756	770	788	792	794		



1 Spherical roller bearings



Spherical roller bearings are suitable where:

- bearing arrangements are subjected to high and very high radial loads ▶672|1.2
- relatively high axial loads occur on one or both sides, in addition to high radial forces ▶672|1.2
- dynamic or static misalignments of the shaft relative to the housing, or deflections of the shaft, must be freely compensated by the bearing ▶673|1.3
- high shock type loads must be supported dynamically
- locating bearings with a very high load carrying capacity are required.

For an overview of other product-specific features, see the Matrix for bearing preselection ▶664.

1
Spherical roller bearing:
comparison of load carrying
capacity with barrel roller bearing
of the same dimensions,
compensation of misalignments

F_r = radial load

C_r = basic dynamic load rating

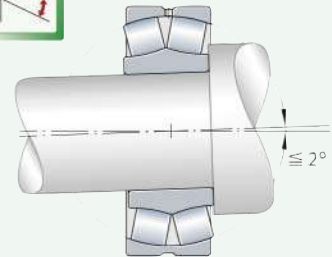
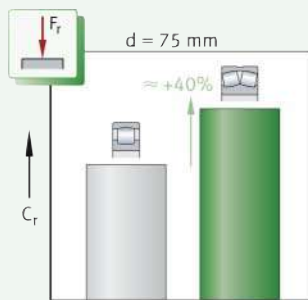

1.1 Bearing design

Design variants

The standard product range of spherical roller bearings comprises:

- bearings of the open design ▶667|□3, ▶668|□4 and ▶668|□5
- bearings with adapter sleeve or withdrawal sleeve ▶671|□7
- sealed bearings ▶670|□6
- bearings for vibratory machinery ▶670.

The bearings are available in the majority of sizes as X-life designs with significantly higher performance ▶671. Larger catalogue bearings and other bearing designs ▶□GL 1.

Bearings of basic design

The outer ring has a curved raceway

Spherical roller bearings are part of the group of radial roller bearings. These self-retaining rolling bearings have two rows of rollers with a mutually curved raceway in the outer ring and two raceways inclined relative to the bearing axis in the inner ring. This raceway design allows these bearings to combine a range of characteristics, which are essential to many applications, in one bearing, such as angular adjustability for example ▶673|1.3. The symmetrical barrel rollers are guided by brass, sheet steel or polyamide cages ▶676|1.9.

Roller contact design

The stress distribution at the contact points between the rollers and raceways is determined by the contact surface of the rollers. As a result, the roller geometry is matched to the raceway. This gives a favourable load distribution over the entire length of the roller and prevents both edge stresses and stress peaks at the ends of the roller ➤667|☐2.

2
Uniform load distribution due to optimised roller and raceway profile

F = load on the rollers

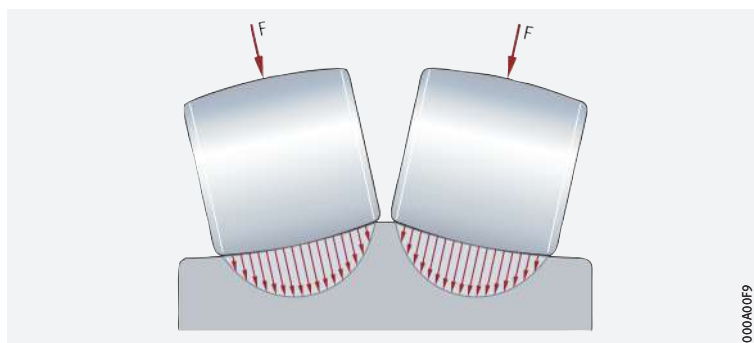

The bore is cylindrical or tapered

Bearings of basic design are supplied without seals and with a cylindrical bore. With the exception of series 233..-A, these bearings are also available with a tapered bore ➤668|☐4.



Bearings with a tapered bore have a bore taper of 1:12 and the suffix K, whereas spherical roller bearings of the series 249, 240 and 241 have a bore taper of 1:30 and the suffix K30 ➤668|☐4 and ➤681|1.12.

Distinguishing features of bearings in the basic design

In addition to the design of the bore (cylindrical or tapered), the specific bearing design is also dependent on the bearing series and bearing size. The key distinguishing features are the:

- design of the inner ring
 - bearings without a central rib on the inner ring ➤667|☐3, ➤668|☐4 and ➤668|☐1
 - bearings with a rigid central rib on the inner ring ➤667|☐3, ➤668|☐4 and ➤669|☐2
 - bearings with a loose central rib on the inner ring ➤668|☐5 and ➤669|☐3
- design of the cage ➤676|1.9.



Bearings with a loose central rib on the inner ring

A loose central rib provides axial guidance of the rollers in the load-free zone ➤668|☐5 and ➤669|☐3. This reduces friction in the bearing, which in turn leads to lower operating temperatures.

3
Spherical roller bearings of basic design, cylindrical bore

F_r = radial load
F_a = axial load

- ① Spherical roller bearing without central rib on inner ring
- ② Spherical roller bearing with rigid central rib on inner ring

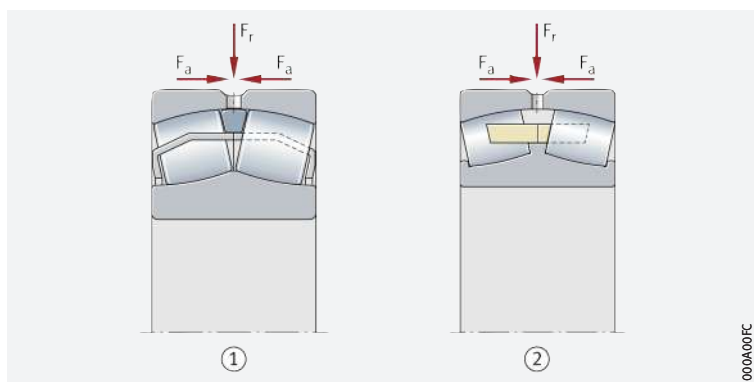

4

Spherical roller bearings of basic design, tapered bore

F_r = radial load
 F_a = axial load

- ① Spherical roller bearing without central rib on inner ring
- ② Spherical roller bearing with rigid central rib on inner ring

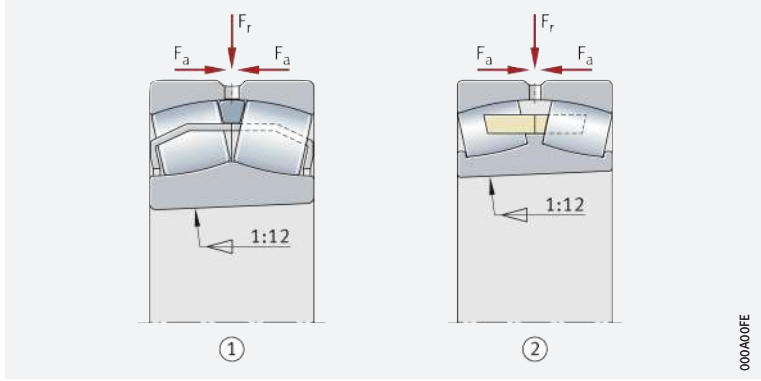

000A00FE

5

Spherical roller bearings of basic design, cylindrical or tapered bore, with loose central rib

F_r = radial load
 F_a = axial load

- ① Cylindrical bore
- ② Tapered bore
- ③ Loose central rib

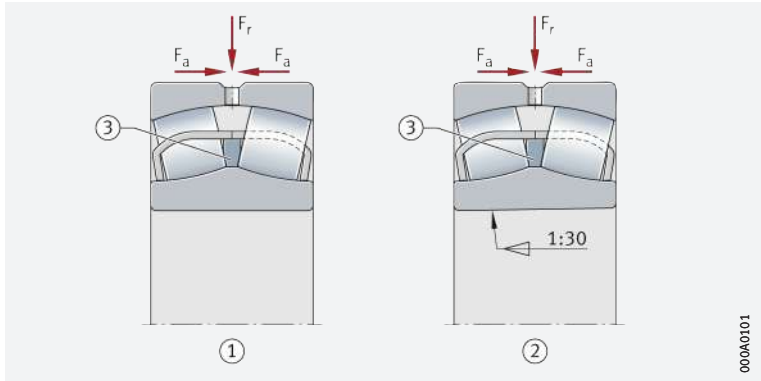

000A0101

Basic bearing design variants

Bearings of basic design are available in the following variants:

- bearings without central rib on inner ring ➤ 668 | 1
- bearings with rigid central rib on inner ring ➤ 669 | 2
- bearings with loose central rib ➤ 669 | 3.

1

Bearing design for bearings without central rib on inner ring

Design		Suffix
①		Two sheet steel cages, surface hardened or coated, guidance on outer ring, X-life E1-XL
②		One brass double comb cage, guided by rollers, inner ring with two lateral retaining ribs, X-life E1A-XL-M
③		Two window cages made from glass fibre reinforced polyamide, guidance on inner ring, X-life E1-XL-TVPB

2

Bearing design for bearings with rigid central rib on inner ring

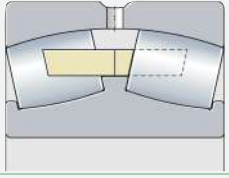
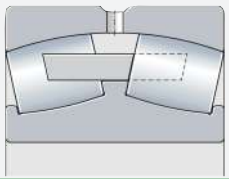
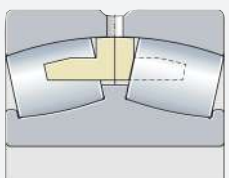
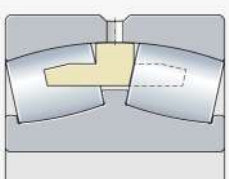
Design	Suffix
<p>①</p> 	<p>MB B-MB</p>
<p>②</p> 	<p>B-FB1</p>
<p>③</p> 	<p>A-MA AS-MA</p>
<p>④</p> 	<p>XL-MA1</p>

3

Bearing design for bearings with loose central rib

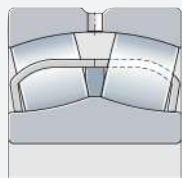
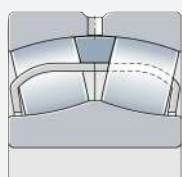
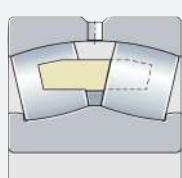
Design	Suffix
<p>①</p> 	<p>BE-XL</p>
<p>②</p> 	<p>BE-XL-JPA-T41A</p>
<p>③</p> 	<p>BEA-XL-MB1</p>



Sealed spherical roller bearings

A selection of standard bearings is also available with seals on both sides ▶ 670 | 6 and ▶ 674 | 1.5.

Series 222, 223 Sealed bearings of series 222 and 223 include an oversize width and the prefix WS in the designation ▶ 670 | 6 and ▶ 676 | 1.9.

Series 240, 241 The main dimensions of sealed bearings of series 240 and 241 correspond to the main dimensions of open bearings.

Further information on sealed spherical roller bearings ▶ TPI 218.



6

Spherical roller bearings
of basic design,
sealed on both sides

- ① Bearing with contact seal 2RSR ($D < 160$)
- ② Bearing with contact seal 2VSR ($160 < D \leq 320$)
- ③ Bearing with contact seal 2RSR ($320 < D \leq 620$)

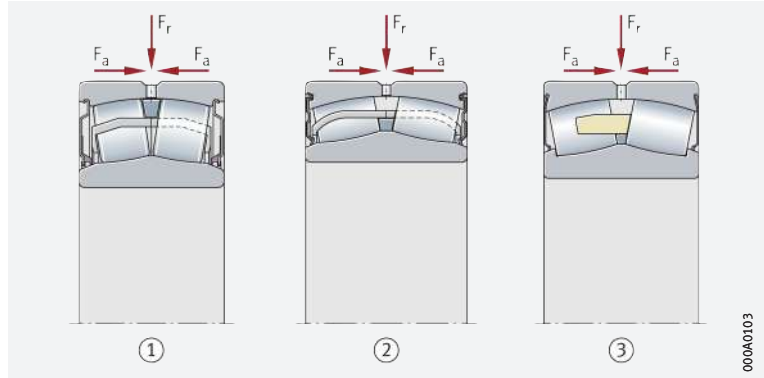

Spherical roller bearings for vibratory machinery

The rolling bearings fitted in vibratory machinery must support not only high loads and high speeds but also accelerations and centrifugal forces. In many cases, these applications involve adverse environmental conditions such as contamination and moisture.

Spherical roller bearings are matched to the operating conditions of vibratory machinery The special spherical roller bearings developed by Schaeffler are matched to the operating conditions in vibratory machinery and have proved highly successful in practical use. In particular, the cages of the rolling bearings are subjected to stresses arising from high radial accelerations. In unfavourable cases, these may be overlaid by axial accelerations as well.

The support of angular misalignments reduces additional sliding motions The rotating imbalance generates a rotating shaft deflection and additional sliding motion within the bearings. This increases the friction and therefore the operating temperature of the bearings. The special spherical roller bearings can support dynamic angular misalignments up to 0,15°.

Basic designs of special spherical roller bearings Schaeffler special spherical roller bearings for vibratory machinery have the main dimensions of dimension series 23 (DIN 616:2000, ISO 15:2017).

Specification T41A (T41D) Schaeffler spherical roller bearings for vibratory machinery are manufactured in accordance with the specification T41A or T41D ▶ 680 | 10. This takes into consideration the particular requirements of the application. The specification defines, for example, the tolerances of the bore and outside diameter, as well as the radial internal clearance of the bearings. The other tolerances are in accordance with tolerance class Normal to ISO 492:2014.



Schaeffler spherical roller bearings for vibratory machinery are described in detail in TPI 197. This can be requested from Schaeffler.

Ready-to-fit mounting kits facilitate the ordering and mounting of bearings

Bearings with adapter sleeve or withdrawal sleeve

Complete bearing mounting kits are also available for use in locating spherical roller bearings with a tapered bore onto a cylindrical shaft journal. These units comprise the bearing, adapter sleeve, tab washer and locknut, or bearing and withdrawal sleeve >671| 7. Adapter sleeves and withdrawal sleeves allow bearings to be located on smooth and stepped shafts >687| 16 and >687| 17. The fixing elements are described in the product tables and must also be stated when placing the order.

7
Spherical roller bearing with adapter sleeve

F_r = radial load
 F_a = axial load

- ① Spherical roller bearing with rigid central rib on inner ring, with adapter sleeve
- ② Adapter sleeve
- ③ Locknut
- ④ Tab washer

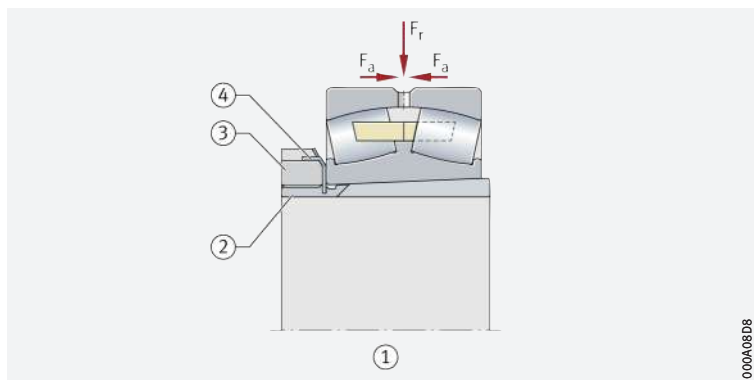

000A08D8

X-life premium quality

Spherical roller bearings are available in numerous series and dimensions as X-life bearings >671| 8. These bearings exhibit considerably higher performance than conventional spherical roller bearings. This is achieved, for example, through the modified internal construction, higher surface quality of the contact areas, optimised contact geometry between rollers and raceways, new roller dimensions with crowned ends and the optimised cage design, as well as through the higher quality of the steel and rolling elements and a loose central rib >669| 3.

X-life

8
Spherical roller bearing in X-life design

- ① Cage
- ② Barrel roller
- ③ Outer ring
- ④ Inner ring



000A018Z



 *Increased customer benefits due to X-life*

Advantages

These technical enhancements offer a range of advantages, such as:

- a more favourable load distribution in the bearing and thus a higher dynamic load carrying capacity of the bearings ►667|📄2
- a higher running accuracy and smooth running
- running with reduced friction and greater energy efficiency
- lower heat generation in the bearing
- higher possible speeds
- lower lubricant consumption and therefore longer maintenance intervals if relubrication is carried out
- a measurably longer operating life of the bearings
- high operational security
- compact, environmentally-friendly bearing arrangements.

 *Lower operating costs, higher machine availability*

In conclusion, these advantages improve the overall cost-efficiency of the bearing position significantly and thus bring about a sustainable increase in the efficiency of the machine and equipment.

 *Suffix XL*

X-life spherical roller bearings include the suffix XL in the designation ►681|1.12 and ►696|📄.

 *Suitable for a further area of application*

Areas of application

Due to their special technical features, X-life spherical roller bearings are highly suitable for bearing arrangements in:

- dryer rolls and calenders
- mining machinery, conveyor belts, crushers, vibrating screens, vertical mills, roller presses
- continuous casting plant
- passenger elevators
- marine propulsion systems.



X-life indicates a high product performance density and thus a particularly significant benefit to the customer. Further information on X-life ►10.

1.2

Load carrying capacity

 *Suitable for very high radial loads and high axial loads*

Spherical roller bearings can support high axial loads in both directions and very high radial loads. They are designed for very high load carrying capacity and, since they have the maximum possible number of large and particularly long barrel rollers (bearings in E1 design), are also suitable for the heaviest loads ►666|1.1.

Axial load carrying capacity of bearings with adapter sleeve or withdrawal sleeve



Due to their internal construction, spherical roller bearings can support high axial loads. Where bearings with adapter sleeves or withdrawal sleeves are located on a smooth shaft without a fixed axial stop (e.g. rigid shoulder), the axial load carrying capacity of the bearing arrangement is dependent on the friction between the shaft and the sleeve.



If there is any doubt about the axial load carrying capacity of the location method, please consult Schaeffler.

 *Friction in the bearing rises with increasing load and speed*

Axial load and higher speeds

Spherical roller bearings support high axial forces from both directions. However, if very high axial loads occur in combination with very high speeds, the resulting increase in friction and temperature in the bearing must be taken into consideration.

1.3 Compensation of angular misalignments

☞ *Spherical roller bearings compensate dynamic and static angular misalignments*

Due to the concave rolling element raceway in the outer ring, spherical roller bearings are capable of angular adjustment ▶666|1.1. As a result, they permit skewing between the outer and inner ring within certain limits, without causing damage to the bearings, and can thus compensate misalignments, shaft deflections and housing deformations.

☞ *The possible skewing is dependent on the magnitude of the load*

Permissible adjustment angle

The permissible adjustment angle is stated for loads $P < 0,1 \cdot C_r$ ▶673|4. The adjustment angles apply if:

- the angular deviation is constant (static angular misalignment)
- the rotating component is the inner ring.

The extent to which the stated values can be used in practice is essentially dependent on the design of the bearing arrangement, sealing etc.

Reduced adjustment angle



If the rotating component is the outer ring, the inner ring undergoes tumbling motion or the adjustment angles are larger than stated in the table, the angular adjustment facility of the bearings is smaller. In such cases, please consult Schaeffler.

Permissible adjustment angle for sealed bearings

In sealed spherical roller bearings, the angular adjustment facility is $0,5^\circ$ from the central position. The sealing function is not adversely affected by misalignments occurring up to this value.

☞ *The permissible adjustment angle is smaller for sealed bearings*

☞ **4**
Permissible adjustment angle of spherical roller bearings

Bearing series	Adjustment angle °
213..-E1, 222..-E1, 222..-BE(BEA), 230, 230..-E1 (E1A), 230..-BE(BEA), 238, 239, 240	1,5
223..-E1, 223..-BE(BEA), 231, 231..E1 (E1A), 231..-BE(BEA), 232, 232..-E1 (E1A), 232..-BE(BEA), 233..-A, 240..-BE(BEA), 241, 241..-BE(BEA)	2

1.4 Lubrication

☞ *The bearings can be lubricated via a circumferential groove and lubrication holes*

In order to ensure good lubrication, most spherical roller bearings have a circumferential groove and three lubrication holes in the outer ring. The lubricant is pressed into the bearing via the groove and holes ▶674|9. Due to the direct and symmetrical feed system, a uniform supply of lubricant to the rows of rollers is achieved. On both sides of the bearing, sufficiently large cavities for collection of the used grease or openings for the escape of grease must be provided.



☞ *Series 213*

Bearings of series 213 with a bore diameter $d \leq 35$ mm do not have a lubrication groove and lubrication hole.

☞ *Lubrication for ungreased bearings*

Open spherical roller bearings are not greased. These bearings must be lubricated with oil or grease.



If shafts with a vertical axis are supported using spherical roller bearings, particular attention must be paid to ensuring the reliable provision of lubricant to the bearings.

☞ *Compatibility with plastic cages*

When using bearings with plastic cages, compatibility between the lubricant and the cage material must be ensured if synthetic oils, lubricating greases with a synthetic oil base or lubricants containing a high proportion of EP additives are used.

☞ *Observe oil change intervals*

Aged oil and additives in the oil can impair the operating life of plastics at high temperatures. As a result, stipulated oil change intervals must be strictly observed.

Suffixes

Lubrication-specific suffixes

H40	without lubrication groove and lubrication holes
H40CA	6 lubrication holes in the outer ring
H40AB	6 lubrication holes in the inner ring
H40AC	6 lubrication holes and one lubrication groove in the inner ring
S	lubrication groove and lubrication holes in the outer ring
SY	3 lubrication holes in the outer ring, no lubrication groove



Lubrication of the bearing via a lubrication groove and lubrication holes in the outer ring

- ① Lubrication groove with lubrication holes
- ② Cavity for collecting grease

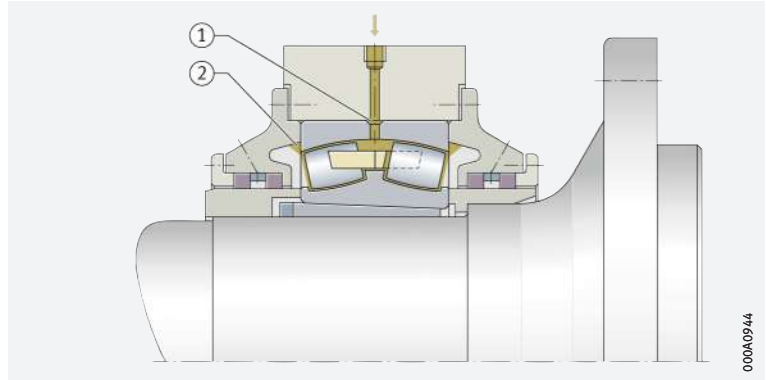

Greased bearings are normally maintenance-free

Sealed bearings

Sealed bearings are supplied already filled with a high quality lithium soap grease with a mineral oil base and are maintenance-free for most applications. Whether or not a bearing requires relubrication during its operating life is dependent on the operating conditions (e.g. on the operating temperatures and operating speeds). Where bearings cannot be relubricated, the grease operating life must be observed.

1.5

Sealing

Certain bearings are also available with seals

Sealed spherical roller bearings have sealing shields on both sides, which protect the bearing reliably against contamination. In order to ensure optimum sealing integrity, various sealing concepts are used, which are determined by size. The bearings should not be heated above +80 °C or washed out prior to mounting.

Series 240, 241

The seal material used is FKM

For spherical roller bearings of series 240 and 241, the standard seal material is fluoro elastomer.



Seals made from fluoro elastomer, such as Viton (FKM, FPM) for example, comprise particularly high performance materials which, when heated above approx. +300 °C, may release vapours and gases that are harmful to health if they are inhaled or come into contact with the eyes. Contact with seals which have been heated to such high temperatures is still dangerous even after cooling. Contact with skin must be avoided in all cases. A doctor must be consulted immediately if such vapours are inhaled. In all cases, the user is responsible for the safe handling of the seals during the operating life, as well as for scrapping the seals and disposing of them correctly.



Such temperatures may occur, for example, if a welding torch is used in the dismantling of a bearing. In these cases, the currently valid safety data sheet must be observed.

1.6 Speeds

Speeds in the product tables

- Two speeds are indicated in the product tables 696 5:
- the kinematic limiting speed n_G
 - the thermal speed rating $n_{\vartheta r}$.

Limiting speeds



The limiting speed n_G is the kinematically permissible speed of the bearing. Even under favourable mounting and operating conditions, this value should not be exceeded without prior consultation with Schaeffler 64.

Reference speeds

$n_{\vartheta r}$ is used to calculate n_{ϑ}

The thermal speed rating $n_{\vartheta r}$ is not an application-oriented speed limit, but is a calculated ancillary value for determining the thermally safe operating speed n_{ϑ} 64.

Bearings with contact seals

For bearings with contact seals, no reference speeds are defined in accordance with DIN ISO 15312:2004. As a result, only the limiting speed n_G is given in the product tables for these bearings.

1.7 Noise

Schaeffler Noise Index

The Schaeffler Noise Index (SGI) is not yet available for this bearing type 69. The data for these bearing series will be introduced and updated in stages.

Further information:

- **medias** <https://medias.schaeffler.com>.

1.8 Temperature range

Limiting values

- The operating temperature of the bearings is limited by:
- the dimensional stability of the bearing rings and rolling elements
 - the cage
 - the lubricant
 - the seals.

Possible operating temperatures of spherical roller bearings 675 5.



5
Permissible temperature ranges

Operating temperature	Open spherical roller bearings		Sealed spherical roller bearings	
	with brass or sheet steel cage	with polyamide cage PA66	Series 222, 223	Series 240, 241
	-30 °C to +200 °C	-30 °C to +120 °C	-40 °C to +100 °C, for short periods up to +120 °C, limited by the lubricant and seal material	-30 °C to +180 °C, for short periods up to +200 °C, limited by the lubricant and seal material



In the event of anticipated temperatures which lie outside the stated values, please contact Schaeffler.

1.9 Cages

🔑 *Solid brass cages are used as standard*

Standard cages for spherical roller bearings ▶668| 1, ▶669| 2, ▶669| 3, ▶677| 6. Other cage designs are available by agreement. With such cages, however, suitability for high speeds and temperatures as well as the basic load ratings may differ from the values for the bearings with standard cages. Essential information on cages ▶110.

🔑 *Solid brass cage or sheet metal cage*

Cages in design B and in bearings without a suffix

Spherical roller bearings with a rigid central rib on the inner ring (design B or bearings without a suffix) have a solid brass cage. Bearings without a cage suffix have sheet metal cages ▶669| 2 and ▶677| 6.

🔑 *Solid brass cage*

Cages in bearings with the suffix MB/MB1, MA/MA1

Bearings with the suffix MB or MB1 have solid brass cages, which are guided on the inner ring. In bearings with the suffix MA or MA1, the solid brass cages are guided on the outer ring ▶669| 2, ▶669| 3 and ▶677| 6.

🔑 *Solid brass cage*

Bearings with the suffix M



































Bearings with the suffix M have a roller-guided solid brass cage ▶668| 1 and ▶677| 6.

🔑 *Sheet steel cage, solid brass cage or solid cage made from polyamide PA66*

Bearings with the suffix E1/BE

Bearings with the suffix E1 and BE and without a cage suffix have sheet steel cages. The two cage halves are retained by a guiding ring or loose central rib in the outer or inner ring ▶668| 1 and ▶677| 6. The other bearings of E1 design have solid cages made from glass fibre reinforced polyamide PA66 or solid brass cages (suffix TVPB or M). The sheet steel cages are surface hardened or coated and, as a result, are particularly well protected against wear.

 **6** Cage, cage suffix, bore code

Bearing series	Cage design								Table/Figure	
	Sheet steel cages		Plastic cage	Brass cage			Steel cage			
	Guidance on			Guidance by rollers	Guidance on					
	inner ring	outer ring	inner ring		inner ring	outer ring				
–	–	TVPB	M	MB1	MB	MA	FB1			
Bore code										
213...-E1-XL	–	08 to 18	04 to 07 19 to 22	–	–	–	–	–	–	➤ 668  1, ① and ③
222...-E1-XL	–	05 to 36	–	–	–	–	–	–	–	➤ 668  1, ①
222...-BE-XL	38 to 48	–	–	–	–	–	–	–	–	➤ 669  3, ①
222...-BEA-XL	–	–	–	–	52 to 72	–	–	–	–	➤ 669  3, ③
223...-E1-XL	–	08 to 30	–	–	–	–	–	–	–	➤ 668  1, ①
223...-BE-XL	32 to 44	–	–	–	–	–	–	–	–	➤ 669  3, ①
223...-BE...-XL- JPA	–	32 to 44	–	–	–	–	–	–	–	➤ 669  3, ②
223...-BEA-XL	–	–	–	–	48 to 56	–	–	–	–	➤ 669  3, ③
230...-E1-XL	–	–	22 to 40	–	–	–	–	–	–	➤ 668  1, ③
230...-E1A-XL	–	–	–	22 to 40	–	–	–	–	–	➤ 668  1, ②
230...-BE-XL	44 to 60	–	–	–	–	–	–	–	–	➤ 669  3, ①
230...-BEA-XL	–	–	–	–	64 to /630	–	–	–	–	➤ 669  3, ③
230	–	–	–	–	–	/670 to /1250	–	–	–	➤ 669  2, ①
231...-E1-XL	–	–	20 to 38	–	–	–	–	–	–	➤ 668  1, ③
231...-E1A-XL	–	–	–	20 to 38	–	–	–	–	–	➤ 668  1, ②
231...-BE-XL	40 to 56	–	–	–	–	–	–	–	–	➤ 669  3, ①
231...-BEA-XL	–	–	–	–	60 to /560	–	–	–	–	➤ 669  3, ③
231	–	–	–	–	–	/600 to /1000	–	–	–	➤ 669  2, ①
232...-E1-XL	–	–	18 to 36	–	–	–	–	–	–	➤ 668  1, ③
232...-E1A-XL	–	–	–	18 to 36	–	–	–	–	–	➤ 668  1, ②
232...-BE-XL	38 to 48	–	–	–	–	–	–	–	–	➤ 669  3, ①
232...-BEA-XL	–	–	–	–	52 to /500	–	–	–	–	➤ 669  3, ③
232	–	–	–	–	–	/530 to /800	–	–	–	➤ 669  2, ①
233...-A, ...-AS	–	–	–	–	–	–	20 to 40	–	–	➤ 669  2, ③
238	–	–	–	–	–	/600 to /1180	/630 ¹⁾	–	–	➤ 669  2, ① and ④
239	–	–	–	–	–	36 to /1180	–	–	–	➤ 669  2, ①
240...-BE-XL	24 to 60	–	–	–	–	–	–	–	–	➤ 669  3, ①
240...-BEA-XL	–	–	–	–	64 to /630	–	–	–	–	➤ 669  3, ③
240	–	–	–	–	–	/670 to /1120	–	–	–	➤ 669  2, ①
241...-BE-XL	22 to 88	–	–	–	–	–	–	–	–	➤ 669  3, ①
241...-BEA-XL	–	–	–	–	92 to /560	–	–	–	–	➤ 669  3, ③
241	–	–	–	–	–	/600 to /1000	–	up to /900	–	➤ 669  2, ① and ②
248	–	–	–	–	–	92 to /1800	–	–	–	➤ 669  2, ①
249	–	–	–	–	–	/670 to /1320	–	–	–	➤ 669  2, ①

1) Cage designation MA1.



For high continuous temperatures and applications with difficult operating conditions, bearings with brass or sheet steel cages should be used. If there is any uncertainty regarding cage suitability, please consult Schaeffler.



1.10 Internal clearance

Radial internal clearance

The standard is CN

Spherical roller bearings with cylindrical and tapered bore are manufactured as standard with radial internal clearance CN (normal) ▶ 678 | 7 and ▶ 679 | 8.



A number of bearings are also available by agreement with the smaller internal clearance C2 and with the larger internal clearance C3 and C4 ▶ 678 | 7 and ▶ 679 | 8.

Spherical roller bearings with cylindrical bore



The values for radial internal clearance correspond to DIN 620-4:2004 (ISO 5753-1:2009) ▶ 678 | 7. They are valid for bearings which are free from load and measurement forces (without elastic deformation).

7
Radial internal clearance
of spherical roller bearings
with cylindrical bore

Nominal bore diameter d		Radial internal clearance							
		C2 (Group 2)		CN (Group N)		C3 (Group 3)		C4 (Group 4)	
mm		μm		μm		μm		μm	
over	incl.	min.	max.	min.	max.	min.	max.	min.	max.
18	24	10	20	20	35	35	45	45	60
24	30	15	25	25	40	40	55	55	75
30	40	15	30	30	45	45	60	60	80
40	50	20	35	35	55	55	75	75	100
50	65	20	40	40	65	65	90	90	120
65	80	30	50	50	80	80	110	110	145
80	100	35	60	60	100	100	135	135	180
100	120	40	75	75	120	120	160	160	210
120	140	50	95	95	145	145	190	190	240
140	160	60	110	110	170	170	220	220	280
160	180	65	120	120	180	180	240	240	310
180	200	70	130	130	200	200	260	260	340
200	225	80	140	140	220	220	290	290	380
225	250	90	150	150	240	240	320	320	420
250	280	100	170	170	260	260	350	350	460
280	315	110	190	190	280	280	370	370	500
315	355	120	200	200	310	310	410	410	550
355	400	130	220	220	340	340	450	450	600
400	450	140	240	240	370	370	500	500	660
450	500	140	260	260	410	410	550	550	720
500	560	150	280	280	440	440	600	600	780
560	630	170	310	310	480	480	650	650	850
630	710	190	350	350	530	530	700	700	920
710	800	210	390	390	580	580	770	770	1010
800	900	230	430	430	650	650	860	860	1120
900	1000	260	480	480	710	710	930	930	1220
1000	1120	290	530	530	770	770	1050	1050	1430
1120	1250	320	580	580	840	840	1140	1140	1560
1250	1400	350	630	630	910	910	1240	1240	1700
1400	1600	380	700	700	1020	1020	1390	1390	1890
1600	1800	420	780	780	1140	1140	1550	1550	2090

Spherical roller bearings with tapered bore



The values for radial internal clearance correspond to DIN 620-4:2004 (ISO 5753-1:2009) ▶ 679 | 8. These are valid for bearings which are free from load and measurement forces (without elastic deformation).

8
Radial internal clearance
of spherical roller bearings
with tapered bore

Nominal bore diameter d		Radial internal clearance							
d		C2 (Group 2)		CN (Group N)		C3 (Group 3)		C4 (Group 4)	
mm		μm		μm		μm		μm	
over	incl.	min.	max.	min.	max.	min.	max.	min.	max.
18	24	15	25	25	35	35	45	45	60
24	30	20	30	30	40	40	55	55	75
30	40	25	35	35	50	50	65	65	85
40	50	30	45	45	60	60	80	80	100
50	65	40	55	55	75	75	95	95	120
65	80	50	70	70	95	95	120	120	150
80	100	55	80	80	110	110	140	140	180
100	120	65	100	100	135	135	170	170	220
120	140	80	120	120	160	160	200	200	260
140	160	90	130	130	180	180	230	230	300
160	180	100	140	140	200	200	260	260	340
180	200	110	160	160	220	220	290	290	370
200	225	120	180	180	250	250	320	320	410
225	250	140	200	200	270	270	350	350	450
250	280	150	220	220	300	300	390	390	490
280	315	170	240	240	330	330	430	430	540
315	355	190	270	270	360	360	470	470	590
355	400	210	300	300	400	400	520	520	650
400	450	230	330	330	440	440	570	570	720
450	500	260	370	370	490	490	630	630	790
500	560	290	410	410	540	540	680	680	870
560	630	320	460	460	600	600	760	760	980
630	710	350	510	510	670	670	850	850	1090
710	800	390	570	570	750	750	960	960	1220
800	900	440	640	640	840	840	1070	1070	1370
900	1000	490	710	710	930	930	1190	1190	1520
1000	1120	540	780	780	1020	1020	1300	1300	1650
1120	1250	600	860	860	1120	1120	1420	1420	1800
1250	1400	660	940	940	1220	1220	1550	1550	1960
1400	1600	740	1060	1060	1380	1380	1750	1750	2200
1600	1800	820	1180	1180	1540	1540	1950	1950	2500



1.11

Dimensions, tolerances

Dimension standards



The main dimensions of spherical roller bearings correspond to DIN 635-2:2009, DIN 616:2000 and ISO 15:2017.

Width tolerances for bearings with the suffixes BE and BEA

For spherical roller bearings with the suffixes BE and BEA, the width tolerances are reduced by half compared to the standard values.

Values ▶ 680 | 9. The running accuracy corresponds to tolerance class 5.



9
Width tolerances
for spherical roller bearings
with the suffixes BE and BEA

Tolerance symbols > 115 |

U = upper limit deviation

L = lower limit deviation

Nominal bore diameter		Width deviation	
d		$t_{\Delta Bs}$	
mm		μm	
over	incl.	U	L
18	30	0	-60
30	50	0	-60
50	80	0	-75
80	120	0	-100
120	180	0	-125
180	250	0	-150
250	315	0	-175
315	400	0	-200
400	500	0	-225
500	630	0	-250
630	800	0	-375
800	1000	0	-500

Specification T41A and T41D

The tolerances for d and D are restricted

Spherical roller bearings to specification T41A and T41D have restricted tolerances for the inside and outside diameter > 680 | 10. In bearings with a tapered bore, the reduced tolerance range applies to the outside diameter only.



10
Restricted diameter tolerances
for the inner and outer ring
in bearings to specification T41A
and T41D

Tolerance symbols > 115 |

U = upper limit deviation

L = lower limit deviation

Inner ring				Outer ring			
Nominal bore diameter		Bore deviation		Nominal outer ring diameter		Outside diameter deviation	
d		$t_{\Delta dmp}$		D		$t_{\Delta Dmp}$	
mm		μm		mm		μm	
over	incl.	U	L	over	incl.	U	L
30	50	0	-7	80	150	-5	-13
50	80	0	-9	150	180	-5	-18
80	120	0	-12	180	315	-10	-23
120	180	0	-15	315	400	-13	-28
180	250	0	-18	400	500	-13	-30
250	315	0	-21	500	630	-15	-35

Chamfer dimensions



The limiting dimensions for chamfer dimensions correspond to DIN 620-6:2004. Overview and limiting values > 135 | 7.11.

Nominal value of chamfer dimension > 696 |

Tolerances



The tolerances for the dimensional and running accuracy of spherical roller bearings correspond to tolerance class Normal in accordance with ISO 492:2014. Tolerance values > 122 | 8. The tolerance values for tapered bores with a taper angle 1:12 correspond to ISO 492 > 132 | 23; the tolerance values for tapered bores with a taper angle 1:30 correspond to > 132 | 24. The running tolerances for spherical roller bearings with the suffixes BE and BEA correspond to tolerance class 5. Tolerance values in accordance with ISO 492 > 126 | 14.



For bearing arrangements with higher requirements for dimensional and running accuracy, spherical roller bearings are available with the tolerance class 5 to ISO 492:2014. In such cases, please consult Schaeffler.

1.12 Suffixes

For a description of the suffixes used in this chapter ▶ 681 | 11 and **medias** interchange ▶ <https://www.schaeffler.de/std/1D52>.

11
*Suffixes and
 corresponding descriptions*

Suffix	Description of suffix	
A-MA, AS-MA	Two brass cages, guidance on outer ring, inner ring with two lateral retaining ribs and one central rib	Standard combinations
B-FB1	One steel cage, guidance on inner ring, inner ring with two lateral retaining ribs and one central rib	
BE-XL	Two sheet steel cages, surface hardened, guidance on inner ring, X-life	
BE-XL-JPA	Two sheet steel cages, surface hardened, guidance on outer ring, X-life	
BEA-XL-MB1	One brass double comb cage, guidance on inner ring, inner ring with two lateral retaining ribs, X-life	
E1-XL	Two sheet steel cages, surface hardened or coated, guidance on outer ring, X-life	
E1-XL-TVPB	Two window cages made from glass fibre reinforced polyamide, guidance on inner ring, X-life	
E1A-XL-M	One brass double comb cage, guided by rollers, inner ring with two lateral retaining ribs, X-life	
MB, B-MB	Two brass cages, guidance on inner ring, inner ring with two lateral retaining ribs and one central rib	
MA1	One brass cage, guidance on outer ring, inner ring with two lateral retaining ribs and one central rib	
2RSR	Contact seal (lip seal) on both sides with sheet steel reinforcement, made from nitrile rubber (NBR); grease fill level 25% to 40%, filled with high pressure grease	Standard
2VSR	Contact seal (lip seal) on both sides with sheet steel reinforcement, made from fluoro rubber (FKM); grease fill level 60% to 100%, filled with high temperature grease	
		continued ▼



11
Suffixes and
corresponding descriptions

Suffix	Description of suffix	
C2	Radial internal clearance C2 (smaller than normal)	Available by agreement
C3	Radial internal clearance C3 (larger than normal)	
C4	Radial internal clearance C4 (larger than C3)	
H40	Without lubrication groove and lubrication holes	
H40CA	6 lubrication holes in the outer ring	
H40AB	6 lubrication holes in the inner ring	
H40AC	6 lubrication holes and one lubrication groove in the inner ring	
H78(*)	3 uniformly distributed threaded holes in one end face of the outer ring (* weight-oriented module letter, please contact us)	
H151	One 45° retaining slot in the outer ring	
H151B	One 15° retaining slot in the outer ring	
K	Tapered bore, taper 1:12	
K30	Tapered bore, taper 1:30	
P5	Dimensional and running accuracy in accordance with ISO tolerance class 5	
S	Lubrication groove and lubrication holes in outer ring	
SY	3 lubrication holes in the outer ring, no lubrication groove	
T41A	For oscillating load with restricted diameter tolerances, radial internal clearance C4	
T41D	For oscillating load with restricted diameter tolerances, radial internal clearance C4, bore with thin chromium coating	
W209B	Inner ring made from case hardening steel	
XL	X-life bearing	

1.13 Structure of bearing designation

Examples of composition of bearing designation

The designation of bearings follows a set model. Examples ▶ 683 | 10 to ▶ 683 | 13. The composition of designations is subject to DIN 623-1 ▶ 102 | 10.

10
Spherical roller bearing with cylindrical bore, without central rib on inner ring: designation structure

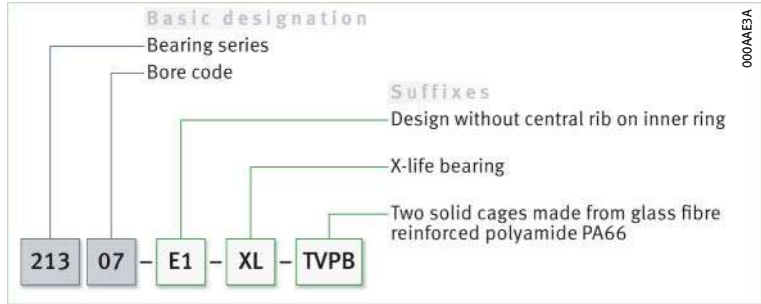

11
Spherical roller bearing for vibratory machinery, with cylindrical bore, without central rib on inner ring, to specification T41A: designation structure

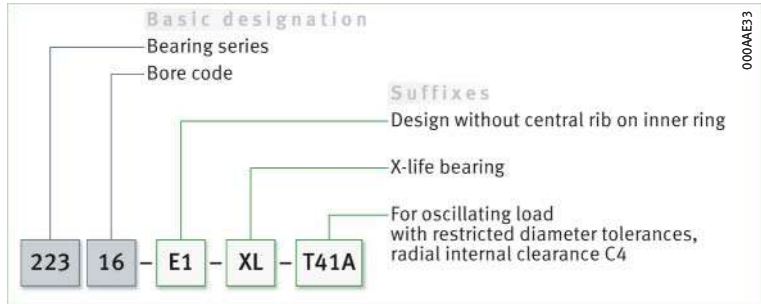

12
Spherical roller bearing with tapered bore, rigid central rib on inner ring: designation structure

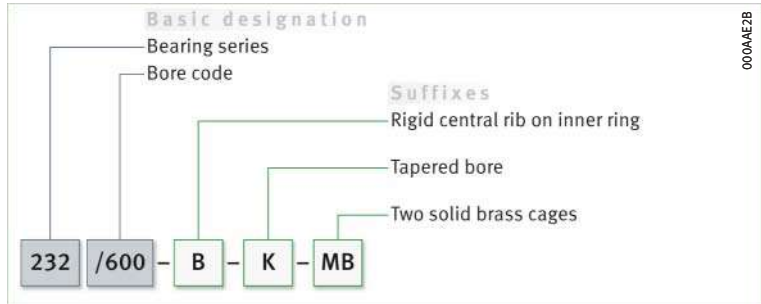

13
Spherical roller bearing with tapered bore and adapter sleeve, without central rib on inner ring: designation structure

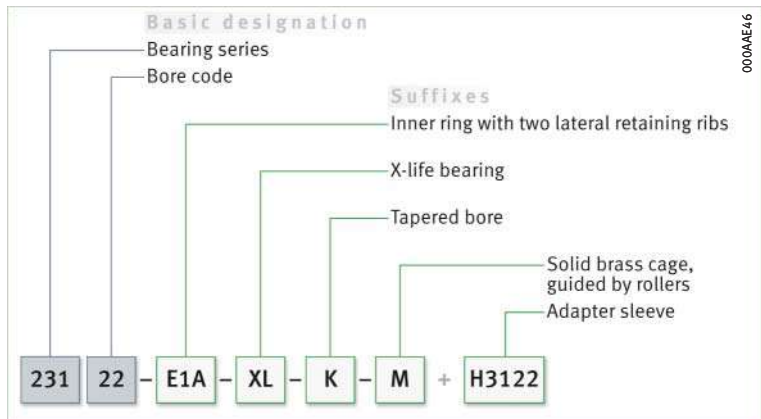

1.14 Dimensioning

$P = a$ substitute force for combined load and various load cases

Equivalent dynamic bearing load

The basic rating life equation $L = (C/P)^P$ used in the dimensioning of bearings under dynamic load assumes a load of constant magnitude and direction. In radial bearings, this is a purely radial load. If this condition is not met, an equivalent dynamic bearing load P must be determined for the rating life calculation. In the case of radial bearings, this is a radial load of constant magnitude and direction, which has the same effect on the rating life as the load occurring in practice.

$F_a/F_r \leq e$ or $F_a/F_r > e$

The calculation of P is dependent on the load ratio F_a/F_r and the calculation factor e ▶ 227 | f1 and ▶ 227 | f2.

f1
Equivalent dynamic load

$$\frac{F_a}{F_r} \leq e \Rightarrow P = F_r + Y_1 \cdot F_a$$

f2
Equivalent dynamic load

$$\frac{F_a}{F_r} > e \Rightarrow P = 0,67 \cdot F_r + Y_2 \cdot F_a$$

Legend

P	N	Equivalent dynamic bearing load
F_r	N	Radial load
F_a	N	Axial load
e, Y_1, Y_2	-	Factors ▶ 696 [table icon]

Equivalent static bearing load

For spherical roller bearings subjected to static load ▶ 684 | f3.

f3
Equivalent static load

$$P_0 = F_{0r} + Y_0 \cdot F_{0a}$$

Legend

P_0	N	Equivalent static bearing load
F_{0r}, F_{0a}	N	Largest radial or axial static bearing load present (maximum load)
Y_0	-	Factor ▶ 696 [table icon]

Static load safety factor

$S_0 = C_0/P_0$

In addition to the basic rating life $L (L_{10h}, L_{hmr})$, it is also always necessary to check the static load safety factor S_0 ▶ 684 | f4.

f4
Static load safety factor

$$S_0 = \frac{C_0}{P_0}$$

Legend

S_0	-	Static load safety factor
C_0	N	Basic static load rating
P_0	N	Equivalent static bearing load.

Axial load carrying capacity of bearings with adapter sleeve



Where bearings with adapter sleeves are located on a smooth shaft without a fixed axial stop (e.g. rigid shoulder), their axial load carrying capacity is dependent on the friction between the shaft and the sleeve ▶ 672 | 1.2.



If there is any doubt about the axial load carrying capacity of the location method, please consult Schaeffler.

1.15 Minimum load

In continuous operation, a minimum load of $P = C_{0r}/100$ is required



In order that no slippage occurs between the contact partners, the spherical roller bearings must be constantly subjected to a sufficiently high radial load. Based on experience, a minimum radial load of the order of $P = C_{0r}/100$ is thus necessary for continuous operation.

If the minimum radial load is lower than indicated above, please consult Schaeffler.

1.16 Design of bearing arrangements

Support bearing rings over their entire circumference and width

In order to allow full utilisation of the load carrying capacity of the bearings and thus also achieve the requisite rating life, the bearing rings must be rigidly and uniformly supported by means of contact surfaces over their entire circumference and over the entire width of the raceway. Support can be provided by means of a cylindrical or tapered seating surface [▶687](#) | [☞ 16](#) to [▶687](#) | [☞ 18](#). The accuracy of mating parts must meet specific requirements [▶688](#) | [☒ 12](#), [▶689](#) | [☒ 13](#), [▶689](#) | [☒ 14](#).

Radial location – bearings with cylindrical bore

For secure radial location, tight fits are necessary

In addition to supporting the rings adequately, the bearings must also be securely located in a radial direction, to prevent creep of the bearing rings on the mating parts under load [▶686](#) | [☞ 14](#). This is generally achieved by means of tight fits between the bearing rings and the mating parts. If the rings are not secured adequately or correctly, this can cause severe damage to the bearings and adjacent machine parts. Influencing factors, such as the conditions of rotation, magnitude of the load, internal clearance, temperature conditions, design of the mating parts, mounting and dismantling options etc., must be taken into consideration in the selection of fits.



If shock type loads occur, tight fits (transition fit or interference fit) are required to prevent the rings from coming loose at any point. Clearance, transition or interference fits [▶150](#) | [☒ 6](#) and [▶158](#) | [☒ 7](#).



The following information provided in Technical principles must be taken into consideration in the design of bearing arrangements:

- conditions of rotation [▶145](#)
- tolerance classes for cylindrical shaft seats (radial bearings) [▶147](#) | [☒ 2](#)
- shaft fits [▶150](#) | [☒ 6](#)
- tolerance classes for bearing seats in housings (radial bearings) [▶148](#) | [☒ 4](#)
- housing fits [▶158](#) | [☒ 7](#)
- shaft tolerances for adapter sleeves and withdrawal sleeves [▶166](#) | [☒ 8](#).



Axial location – bearings with cylindrical bore

The bearings must also be securely located in an axial direction

As a tight fit alone is not normally sufficient to also locate the bearing rings securely on the shaft or in the housing bore in an axial direction, this must usually be achieved by means of an additional axial location or retention method. The axial location of the bearing rings must be matched to the type of bearing arrangement. Shaft and housing shoulders, housing covers, nuts, spacer rings and retaining rings etc., are fundamentally suitable [▶686](#) | [☞ 14](#), [▶686](#) | [☞ 15](#), [▶687](#) | [☞ 16](#) and [▶687](#) | [☞ 17](#).

14

Location of a spherical roller bearing in a rotary kiln – example

- ① Spherical roller bearing 24164-BE-XL
- ② Felt ring seals
- ③ Labyrinths with relubrication facility
- ④ End cap
- ⑤ Oil feed ducts
- ⑥ Oil grooves
- ⑦ Flake graphite cast iron housing

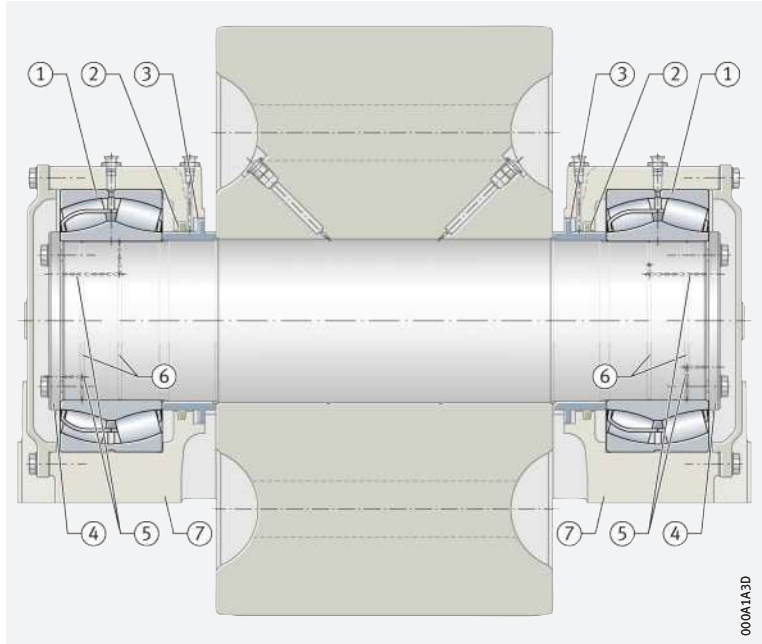

Axial location – bearings with tapered bore

Location by means of locknut and tab washer

If a bearing with a tapered bore is mounted directly on a tapered shaft journal, the bearing can be axially located with ease using a locknut and tab washer ▶ 686 | 15.

15

Spherical roller bearing with tapered bore, mounted directly on the tapered shaft journal

- ① Tapered journal with fixing thread
- ② Locknut
- ③ Tab washer

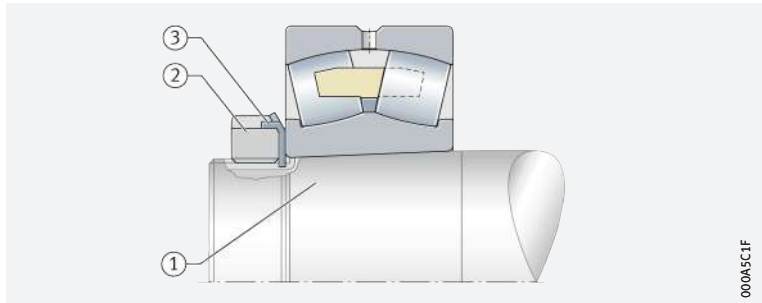

Location of bearings by means of adapter sleeve or withdrawal sleeve

Mounting can be carried out quickly and reliably by means of wrench sets from Schaeffler

The location of spherical roller bearings by means of adapter sleeve or withdrawal sleeve on a smooth or stepped cylindrical shaft is an easy-to-fit and operationally reliable method ▶ 666 | 1.1 and ▶ 687 | 16. It requires no additional means of retention on the shaft. The bearings can be positioned at any point on smooth shafts. Axial load carrying capacity of such bearing arrangements ▶ 672 | 1.2. Further information on adapter sleeves ▶ 1692.

Mounting of the adapter sleeve and withdrawal sleeve

While the bearing is being slid onto the adapter sleeve, the withdrawal sleeve is pressed into the tapered bearing bore until the required reduction in radial internal clearance is achieved. The position is fixed by means of a locknut. The inner ring is abutted against a shoulder on the shaft ▶ 687 | 16. The required adapter sleeves or withdrawal sleeves must be stated additionally in the order ▶ 666 | 1.1 and ▶ 756 | 15.

16

Location of spherical roller bearings by means of adapter sleeve or withdrawal sleeve

- ① Bearing with adapter sleeve, adapter sleeve nut (shaft nut) and tab washer
- ② Bearing with withdrawal sleeve, locknut and tab washer, abutment of the inner ring against a shaft shoulder

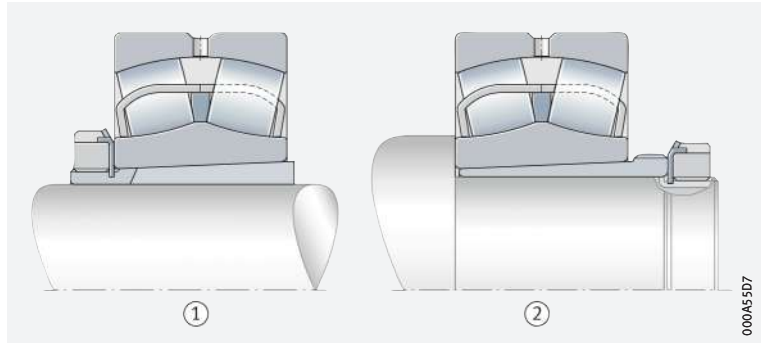

Location by means of adapter sleeve, axial abutment by means of a support ring



If an adapter sleeve connection is used and it is expected that the frictional forces of the sleeve cannot reliably support high axial forces, the bearing inner ring can be abutted by means of a support ring against a shaft shoulder ▶687| 17. Axial guidance forces in the opposing direction are supported by means of form fit. The mounting dimensions of the support ring in the product tables must be observed ▶756| 18.

17

Location of a spherical roller bearing by means of adapter sleeve and support ring on a stepped shaft

- ① Spherical roller bearing
- ② Adapter sleeve
- ③ Support ring
- ④ Locknut with tab washer

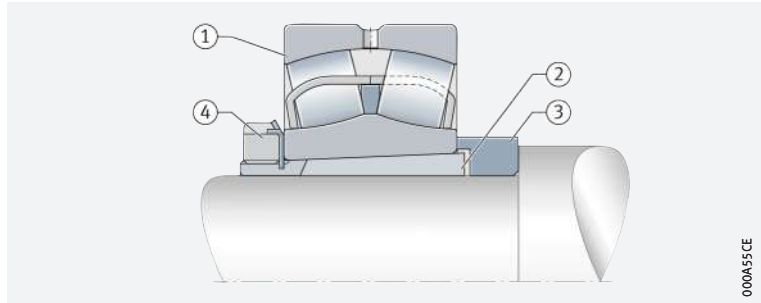

Location of bearings with a tapered bore on a tapered shaft

Axial location by means of fixing nut, ring nut and locking pin

Where shafts must support high torques, it is not always permissible to cut the thread for the fixing nut of the bearing into the shaft due to the notch effect. In this case, a slot with well rounded transitions is grooved into the shaft. A split ring with an external thread is inserted in the slot and secured by means of a feather key or pin. The fixing nut is screwed onto the ring nut and secured ▶687| 18.

18

Location of a spherical roller bearing on a tapered shaft

- ① Spherical roller bearing
- ② Fixing nut with retaining bracket
- ③ Retaining pin
- ④ Ring nut

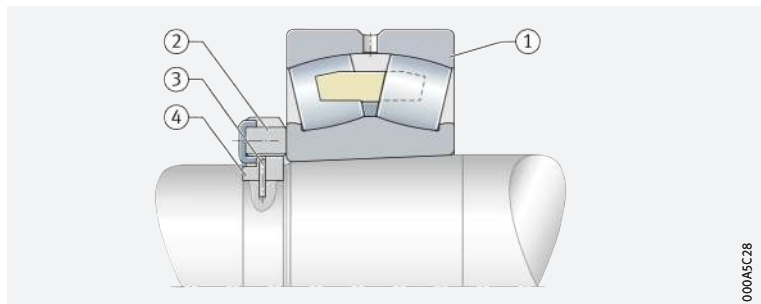

Dimensional, geometrical and running accuracy of cylindrical bearing seats

☞ *A minimum of IT6 should be provided for the shaft seat and a minimum of IT7 for the housing seat*

The accuracy of the cylindrical bearing seat on the shaft and in the housing should correspond to the accuracy of the bearing used. For spherical roller bearings with the tolerance class Normal, the shaft seat should correspond to a minimum of standard tolerance grade IT6 and the housing seat to a minimum of IT7. Guide values for the geometrical and positional tolerances of bearing seating surfaces ▶ 688 | 12, tolerances t_1 to t_3 in accordance with ▶ 168 | 11. Numerical values for IT grades ▶ 689 | 13.

12
Guide values for the geometrical and positional tolerances of bearing seating surfaces

Bearing tolerance class		Bearing seating surface	Standard tolerance grades to ISO 286-1 (IT grades)			
to ISO 492	to DIN 620		Diameter tolerance	Roundness tolerance	Parallelism tolerance	Total axial runout tolerance of abutment shoulder
				t_1	t_2	t_3
Normal	PN (P0)	Shaft	IT6 (IT5)	Circumferential load IT4/2	Circumferential load IT4/2	IT4
				Point load IT5/2	Point load IT5/2	
		Housing	IT7 (IT6)	Circumferential load IT5/2	Circumferential load IT5/2	IT5
				Point load IT6/2	Point load IT6/2	
5	P5	Shaft	IT5	Circumferential load IT2/2	Circumferential load IT2/2	IT2
				Point load IT3/2	Point load IT3/2	
		Housing	IT6	Circumferential load IT3/2	Circumferential load IT3/2	IT3
				Point load IT4/2	Point load IT4/2	

13

Numerical values for ISO standard tolerances (IT grades) to ISO 286-1:2010

IT grade	Nominal dimension in mm								
	over	18	30	50	80	120	180	250	315
	incl.	30	50	80	120	180	250	315	400
Values in μm									
IT2	2,5	2,5	3	4	5	7	8	9	
IT3	4	4	5	6	8	10	12	13	
IT4	6	7	8	10	12	14	16	18	
IT5	9	11	13	15	18	20	23	25	
IT6	13	16	19	22	25	29	32	36	
IT7	21	25	30	35	40	46	52	57	

continued ▼

13

Numerical values for ISO standard tolerances (IT grades) to ISO 286-1:2010

IT grade	Nominal dimension in mm							
	over	400	500	630	800	1000	1250	1600
	incl.	500	630	800	1000	1250	1600	2000
Values in μm								
IT2	10	11	13	15	18	21	25	
IT3	15	16	18	21	24	29	35	
IT4	20	22	25	28	33	39	46	
IT5	27	32	36	40	47	55	65	
IT6	40	44	50	56	66	78	92	
IT7	63	70	80	90	105	125	150	

continued ▲

Roughness of cylindrical bearing seating surfaces

Ra must not be too high

The roughness of the bearing seats must be matched to the tolerance class of the bearings. The mean roughness value Ra must not be too high, in order to maintain the interference loss within limits. The shafts must be ground, while the bores must be precision turned. Guide values as a function of the IT grade of bearing seating surfaces ▶ 689 | 14.

14

Roughness values for cylindrical bearing seating surfaces – guide values

Nominal diameter of the bearing seat d (D) mm		Recommended mean roughness value for ground bearing seats Ramax			
		μm			
		Diameter tolerance (IT grade)			
over	incl.	IT7	IT6	IT5	IT4
–	80	1,6	0,8	0,4	0,2
80	500	1,6	1,6	0,8	0,4
500	1 250	3,2 ¹⁾	1,6	1,6	0,8

¹⁾ For the mounting of bearings using the hydraulic method, a value Ra = 1,6 μm must not be exceeded



Tolerances for tapered bearing seats

Specifications for tapered bearing seats

For bearings located directly on a tapered shaft journal, the data are in accordance with ▶ 171 | 12.

☞ *The contact surfaces for the rings must be of sufficient height*

Mounting dimensions for the contact surfaces of bearing rings

The mounting dimensions of the shaft and housing shoulders, and spacer rings etc., must ensure that the contact surfaces for the bearing rings are of sufficient height. However, they must also reliably prevent rotating parts of the bearing from grazing stationary parts. Proven mounting dimensions for the radii and diameters of the abutment shoulders are given in the product tables. These dimensions are limiting dimensions (maximum or minimum dimensions); the actual values should not be higher or lower than specified.

☞ *A large range of housings is available*

Suitable bearing housings for spherical roller bearings

For economical, operationally reliable and easily interchangeable bearing arrangement units, the spherical roller bearings can also be combined with Schaeffler bearing housings ▶ 690 | 19. These easy-to-fit units fulfil all of the requirements for modern machine and plant designs with favourable maintenance-related characteristics.



Due to the large number of application areas, an extensive range of bearing housings is available for bearings with cylindrical and tapered bores. These include split and unsplit plummer block housings, take-up housings, flanged housings and housings for specific industrial and railway applications. Detailed information on bearing housings can be found in publication GK 1 ▶ <https://www.schaeffler.de/std/1D54>. This book can be ordered from Schaeffler.

19

Split plummer block housing SNS with a spherical roller bearing

- ① Split plummer block housing SNS
- ② Spherical roller bearing



000A02F

1.17 Mounting and dismounting



The mounting and dismounting options for spherical roller bearings, by thermal, hydraulic or mechanical methods, must also be taken into consideration in the design of the bearing position.

Example ► 691 | 20.

20

Mounting of large bearings with a hydraulic nut

- ① Spherical roller bearing with tapered bore mounted directly on the tapered shaft journal
- ② Hydraulic nut

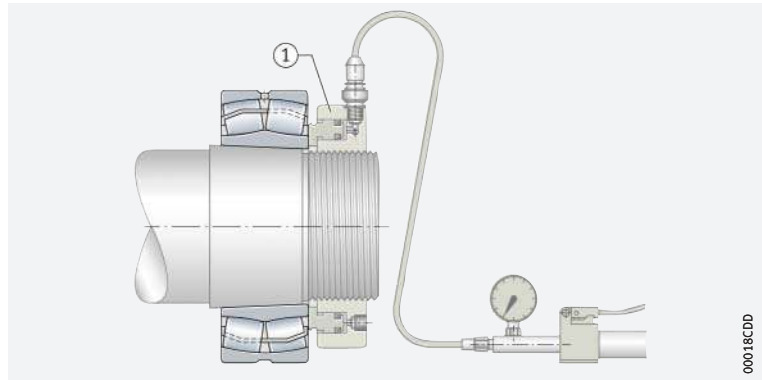

☞ Ensure that the bearings are not damaged during mounting

Spherical roller bearings are not separable. In the mounting of non-separable bearings, the mounting forces must always be applied to the bearing ring with a tight fit.

☞ Suitable methods

Mounting of bearings with a tapered bore

Bearings with a tapered bore are mounted with a tight fit on the shaft or adapter and withdrawal sleeve ► 686 | 15, ► 687 | 16 and ► 687 | 17. The measurement of the reduction in radial internal clearance or of the axial drive-up distance of the inner ring on the tapered bearing seat serves as an indication of the tight fit.



The measurement is usually carried out with a feeler gauge

Measuring the reduction in radial internal clearance during mounting of the bearings

The reduction in radial internal clearance is the difference between the radial internal clearance before mounting and the bearing clearance after mounting of the bearing $\text{▶692} | \text{Ⓢ} 21$, $\text{▶693} | \text{Ⓢ} 15$ and $\text{▶694} | \text{Ⓢ} 16$. The radial internal clearance must be measured first. During pressing on, the radial clearance (bearing clearance) must be checked until the necessary reduction in the radial internal clearance and thus the required tight fit is achieved.



If the values in the table are observed, secure radial location of the bearings will be achieved, i.e. the inner ring will be prevented from creeping under load. However, the mounting method does not ensure that an operating clearance which is appropriate to the application is also achieved simultaneously. In order to select the requisite internal clearance class, other factors influencing the operating clearance, such as the temperature difference between the inner and outer ring and the housing bore tolerance for example, must be taken into consideration.



If there is any uncertainty regarding the selection of an internal clearance class for a specific application, please consult Schaeffler.

21
Reduction in radial internal clearance

- s_a = axial press-on distance (axial drive-up distance of the bearing)
- s_r = radial internal clearance before mounting
- s_{r1} = radial internal clearance after mounting
- $s_r - s_{r1}$ = reduction in radial internal clearance

- ① Before mounting
- ② After mounting

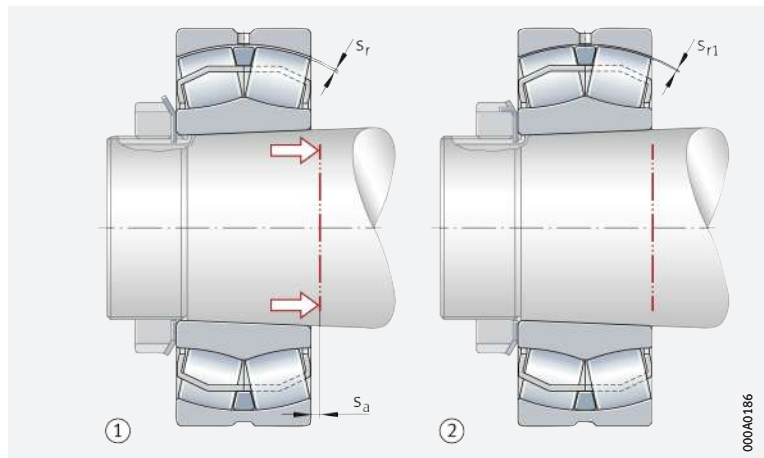

000A0186

15

Reduction in radial internal clearance in mounting of spherical roller bearings with tapered bore

Nominal bore diameter		Radial internal clearance before mounting in accordance with DIN 620-4:2004 (ISO 5753-1:2009)						Reduction in radial internal clearance during mounting ¹⁾	
d		CN (Group N)		C3 (Group 3)		C4 (Group 4)		mm	
mm		mm		mm		mm		mm	
over	incl.	min.	max.	min.	max.	min.	max.	min.	max.
24	30	0,03	0,04	0,04	0,055	0,055	0,075	0,015	0,02
30	40	0,035	0,05	0,05	0,065	0,065	0,085	0,02	0,025
40	50	0,045	0,06	0,06	0,08	0,08	0,1	0,025	0,03
50	65	0,055	0,075	0,075	0,095	0,095	0,12	0,03	0,04
65	80	0,07	0,095	0,095	0,12	0,12	0,15	0,04	0,05
80	100	0,08	0,11	0,11	0,14	0,14	0,18	0,045	0,06
100	120	0,1	0,135	0,135	0,17	0,17	0,22	0,05	0,07
120	140	0,12	0,16	0,16	0,2	0,2	0,26	0,065	0,09
140	160	0,13	0,18	0,18	0,23	0,23	0,3	0,075	0,1
160	180	0,14	0,2	0,2	0,26	0,26	0,34	0,08	0,11
180	200	0,16	0,22	0,22	0,29	0,29	0,37	0,09	0,13
200	225	0,18	0,25	0,25	0,32	0,32	0,41	0,1	0,14
225	250	0,2	0,27	0,27	0,35	0,35	0,45	0,11	0,15
250	280	0,22	0,3	0,3	0,39	0,39	0,49	0,12	0,17
280	315	0,24	0,33	0,33	0,43	0,43	0,54	0,13	0,19
315	355	0,27	0,36	0,36	0,47	0,47	0,59	0,15	0,21
355	400	0,3	0,4	0,4	0,52	0,52	0,65	0,17	0,23
400	450	0,33	0,44	0,44	0,57	0,57	0,72	0,2	0,26
450	500	0,37	0,49	0,49	0,63	0,63	0,79	0,21	0,28
500	560	0,41	0,54	0,54	0,68	0,68	0,87	0,24	0,32
560	630	0,46	0,6	0,6	0,76	0,76	0,98	0,26	0,35
630	710	0,51	0,67	0,67	0,85	0,85	1,09	0,3	0,4
710	800	0,57	0,75	0,75	0,96	0,96	1,22	0,34	0,45
800	900	0,64	0,84	0,84	1,07	1,07	1,37	0,37	0,5
900	1 000	0,71	0,93	0,93	1,19	1,19	1,52	0,41	0,55
1 000	1 120	0,78	1,02	1,02	1,3	1,3	1,65	0,45	0,6
1 120	1 250	0,86	1,12	1,12	1,42	1,42	1,8	0,49	0,65
1 250	1 400	0,94	1,22	1,22	1,55	1,55	1,96	0,55	0,72

¹⁾ Valid only for solid steel shafts and hollow shafts with a bore no larger than half the shaft diameter. The following applies: bearings with a radial internal clearance before mounting in the upper half of the tolerance range are mounted using the larger value for the reduction in radial internal clearance, while bearings in the lower half of the tolerance range are mounted using the smaller value for the reduction in radial internal clearance.



Measuring the axial drive-up distance of the inner ring

16
Axial drive-up distance
of the inner ring
in spherical roller bearings
with a tapered bore

Nominal bore diameter d		Drive-up distance on taper 1:12 ¹⁾				Drive-up distance on taper 1:30 ¹⁾				Minimum radial internal clearance required after mounting, control value		
		Shaft		Sleeve		Shaft		Sleeve		With CN (Group N)	With C3 (Group 3)	With C4 (Group 4)
over	incl.	min.	max.	min.	max.	min.	max.	min.	max.	min.	min.	min.
24	30	0,3	0,35	0,3	0,4	-	-	-	-	0,015	0,02	0,035
30	40	0,35	0,4	0,35	0,45	-	-	-	-	0,015	0,025	0,04
40	50	0,4	0,45	0,45	0,5	-	-	-	-	0,02	0,03	0,05
50	65	0,45	0,6	0,5	0,7	-	-	-	-	0,025	0,035	0,055
65	80	0,6	0,75	0,7	0,85	-	-	-	-	0,025	0,04	0,07
80	100	0,7	0,9	0,75	1	1,7	2,2	1,8	2,4	0,035	0,05	0,08
100	120	0,7	1,1	0,8	1,2	1,9	2,7	2	2,8	0,05	0,065	0,1
120	140	1,1	1,4	1,2	1,5	2,7	3,5	2,8	3,6	0,055	0,08	0,11
140	160	1,2	1,6	1,3	1,7	3	4	3,1	4,2	0,055	0,09	0,13
160	180	1,3	1,7	1,4	1,9	3,2	4,2	3,3	4,6	0,06	0,1	0,15
180	200	1,4	2	1,5	2,2	3,5	4,5	3,6	5	0,07	0,1	0,16
200	225	1,6	2,2	1,7	2,4	4	5,5	4,2	5,7	0,08	0,12	0,18
225	250	1,7	2,4	1,8	2,6	4,2	6	4,6	6,2	0,09	0,13	0,2
250	280	1,9	2,6	2	2,9	4,7	6,7	4,8	6,9	0,1	0,14	0,22
280	315	2	3	2,2	3,2	5	7,5	5,2	7,7	0,11	0,15	0,24
315	355	2,4	3,4	2,6	3,6	6	8,2	6,2	8,4	0,12	0,17	0,26
355	400	2,6	3,6	2,9	3,9	6,5	9	6,8	9,2	0,13	0,19	0,29
400	450	3,1	4,1	3,4	4,4	7,7	10	8	10,4	0,13	0,2	0,31
450	500	3,3	4,4	3,6	4,8	8,2	11	8,4	11,2	0,16	0,23	0,35
500	560	3,7	5	4,1	5,4	9,2	12,5	9,6	12,8	0,17	0,25	0,36
560	630	4	5,4	4,4	5,9	10	13,5	10,4	14	0,2	0,29	0,41
630	710	4,6	6,2	5,1	6,8	11,5	15,5	12	16	0,21	0,31	0,45
710	800	5,3	7	5,8	7,6	13,3	17,5	13,6	18	0,23	0,35	0,51
800	900	5,7	7,8	6,3	8,5	14,3	19,5	14,8	20	0,27	0,39	0,57
900	1000	6,3	8,5	7	9,4	15,8	21	16,4	22	0,3	0,43	0,64
1000	1120	6,8	9	7,6	10,2	17	23	18	24	0,32	0,48	0,7
1120	1250	7,4	9,8	8,3	11	18,5	25	19,6	26	0,34	0,54	0,77
1250	1400	8,3	10,8	9,3	12,1	21	27	22,2	28,3	0,36	0,59	0,84

¹⁾ Valid only for solid steel shafts and hollow shafts with a bore no larger than half the shaft diameter. The following applies: bearings with a radial internal clearance before mounting in the upper half of the tolerance range are mounted using the larger value for the axial drive-up distance, while bearings in the lower half of the tolerance range are mounted using the smaller value for the axial drive-up distance.

Schaeffler Mounting Handbook

Rolling bearings must be handled with great care

Rolling bearings are well-proven precision machine elements for the design of economical and reliable bearing arrangements, which offer high operational security. In order that these products can function correctly and achieve the envisaged operating life without detrimental effect, they must be handled with care.



The Schaeffler Mounting Handbook MH 1 gives comprehensive information about the correct storage, mounting, dismounting and maintenance of rotary rolling bearings ► <https://www.schaeffler.de/std/1D53>. It also provides information which should be observed by the designer, in relation to the mounting, dismounting and maintenance of bearings, in the original design of the bearing position. This book is available from Schaeffler on request.

1.18 Legal notice regarding data freshness

The further development of products may also result in technical changes to catalogue products

Of central interest to Schaeffler is the further development and optimisation of its products and the satisfaction of its customers. In order that you, as the customer, can keep yourself optimally informed about the progress that is being made here and with regard to the current technical status of the products, we publish any product changes which differ from the printed version in our electronic product catalogue.



We therefore reserve the right to make changes to the data and illustrations in this catalogue. This catalogue reflects the status at the time of printing. More recent publications released by us (as printed or digital media) will automatically precede this catalogue if they involve the same subject. Therefore, please always use our electronic product catalogue to check whether more up-to-date information or modification notices exist for your desired product.

Link to electronic product catalogue



The following link will take you to the Schaeffler electronic product catalogue: ► <https://medias.schaeffler.com>.

1.19 Further information



In addition to the data in this chapter, the following chapters in Technical principles must also be observed in the design of bearing arrangements:

- Determining the bearing size ► 34
- Rigidity ► 54
- Friction and increases in temperature ► 56
- Speeds ► 64
- Bearing data ► 97
- Lubrication ► 70
- Sealing ► 182
- Design of bearing arrangements ► 139
- Mounting and dismounting ► 191.





Spherical roller bearings

With cylindrical or tapered bore

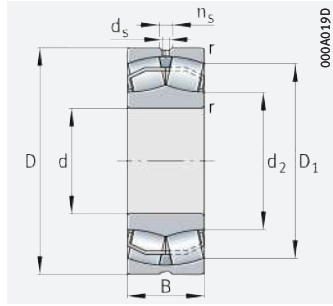

Cylindrical bore

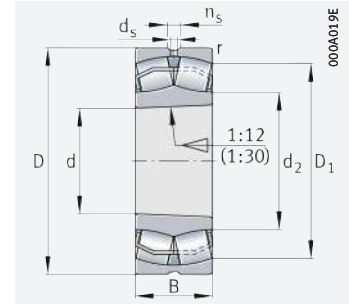

Tapered bore

d = 20 – 50 mm

Main dimensions			Basic load ratings		Fatigue limit load C_{ur} N	Limiting speed n_G min ⁻¹	Speed rating $n_{\theta r}$ min ⁻¹	Mass m ≈ kg	Designation ▶ 681 1.12 ▶ 683 1.13 X-life ▶ 671
d	D	B	dyn. C_r kN	stat. C_{0r} kN					
20	52	15	41	33	3 700	16 000	9 700	0,16	21304-E1-XL-TVPB
25	52	18	48,5	42,5	4 800	14 400	9 200	0,191	22205-E1-XL
	52	18	48,5	42,5	4 800	14 400	9 200	0,175	22205-E1-XL-K
	62	17	52	43,5	4 750	13 900	8 400	0,254	21305-E1-XL-TVPB
30	62	20	64	57	6 900	12 500	7 800	0,275	22206-E1-XL
	62	20	64	57	6 900	12 500	7 800	0,275	22206-E1-XL-K
	72	19	72	63	7 000	12 000	7 300	0,386	21306-E1-XL-TVPB
35	72	23	89	81	9 400	10 700	7 000	0,434	22207-E1-XL
	72	23	89	81	9 400	10 700	7 000	0,434	22207-E1-XL-K
	80	21	83	74	8 100	10 900	6 800	0,496	21307-E1-XL-K-TVPB
	80	21	83	74	8 100	10 900	6 800	0,503	21307-E1-XL-TVPB
40	80	23	101	91	11 800	10 500	6 200	0,528	22208-E1-XL
	80	23	101	91	11 800	10 500	6 200	0,528	22208-E1-XL-K
	90	23	109	107	14 300	9 800	5 200	0,749	21308-E1-XL
	90	23	109	107	14 300	9 800	5 200	0,749	21308-E1-XL-K
	90	33	156	149	13 100	7 600	5 500	1,05	22308-E1-XL
	90	33	156	149	13 100	7 600	5 500	1	22308-E1-XL-K
45	85	23	104	99	12 700	10 100	5 600	0,589	22209-E1-XL
	85	23	104	99	12 700	10 100	5 600	0,577	22209-E1-XL-K
	100	25	129	130	17 300	9 000	4 750	0,999	21309-E1-XL
	100	25	129	130	17 300	9 000	4 750	0,999	21309-E1-XL-K
	100	36	187	183	16 000	6 800	5 000	1,39	22309-E1-XL
	100	36	187	183	16 000	6 800	5 000	1,4	22309-E1-XL-K
50	90	23	109	107	14 300	9 800	5 100	0,606	22210-E1-XL
	90	23	109	107	14 300	9 800	5 100	0,608	22210-E1-XL-K
	110	27	129	130	17 300	9 000	5 400	1,32	21310-E1-XL
	110	27	129	130	17 300	9 000	5 400	1,32	21310-E1-XL-K
	110	40	229	223	20 100	6 300	4 800	1,9	22310-E1-XL
	110	40	229	223	20 100	6 300	4 800	1,9	22310-E1-XL-K

medias ▶ <https://www.schaeffler.de/std/1EC9>

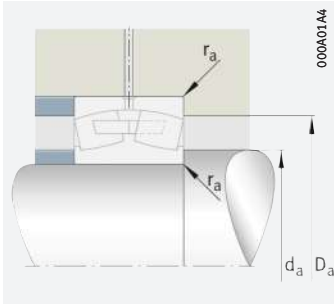

Mounting dimensions

Dimensions						Mounting dimensions			Calculation factors			
d	r	D ₁	d ₂	d _s	n _s	d _a	D _a	r _a	e	Y ₁	Y ₂	Y ₀
	min.	≈	≈			min.	max.	max.				
20	1,1	43	28,9	–	–	27	45	1	0,3	2,25	3,34	2,2
	1	44,4	31,5	3,2	4,8	30,6	46,4	1	0,33	2,07	3,09	2,03
	1,1	51	35,2	–	–	32	55	1	0,28	2,43	3,61	2,37
30	1	53,7	38,1	3,2	4,8	35,6	56,4	1	0,3	2,26	3,37	2,21
	1	53,7	38,1	3,2	4,8	35,6	54,6	1	0,3	2,26	3,37	2,21
	1,1	59,9	41,5	–	–	37	65	1	0,27	2,49	3,71	2,43
35	1,1	62,5	43,9	3,2	4,8	42	65	1	0,31	2,21	3,29	2,16
	1,1	62,5	43,9	3,2	4,8	42	65	1	0,31	2,21	3,29	2,16
	1,5	66,6	47,4	–	–	44	71	1,5	0,26	2,55	3,8	2,5
	1,5	66,6	47,4	–	–	44	71	1,5	0,26	2,55	3,8	2,5
40	1,1	70,4	48,8	3,2	4,8	47	73	1	0,27	2,49	3,71	2,43
	1,1	70,4	48,8	3,2	4,8	47	73	1	0,27	2,49	3,71	2,43
	1,5	80,8	59,9	3,2	4,8	49	81	1,5	0,23	2,95	4,4	2,89
	1,5	80,8	59,9	3,2	4,8	49	81	1,5	0,23	2,95	4,4	2,89
	1,5	76	52,4	3,2	6,5	49	81	1,5	0,36	1,86	2,77	1,82
	1,5	76	52,4	3,2	6,5	49	81	1,5	0,36	1,86	2,77	1,82
45	1,1	75,6	55	3,2	4,8	52	78	1	0,25	2,74	4,08	2,68
	1,1	75,6	55	3,2	4,8	52	78	1	0,25	2,74	4,08	2,68
	1,5	89,8	67,6	3,2	4,8	54	91	1,5	0,21	3,17	4,72	3,1
	1,5	89,8	67,6	3,2	4,8	54	91	1,5	0,21	3,17	4,72	3,1
	1,5	84,7	58,9	3,2	6,5	54	91	1,5	0,36	1,9	2,83	1,86
	1,5	84,7	58,9	3,2	6,5	54	91	1,5	0,36	1,9	2,83	1,86
50	1,1	80,8	59,9	3,2	4,8	57	83	1	0,23	2,95	4,4	2,89
	1,1	80,8	59,9	3,2	4,8	57	83	1	0,23	2,95	4,4	2,89
	2	89,8	67,7	3,2	4,8	61	99	2	0,21	3,17	4,72	3,1
	2	89,8	67,7	3,2	4,8	61	99	2	0,21	3,17	4,72	3,1
	2	92,6	63	3,2	6,5	61	99	2	0,36	1,86	2,77	1,82
	2	92,6	63	3,2	6,5	61	99	2	0,36	1,86	2,77	1,82





Spherical roller bearings

With cylindrical or tapered bore

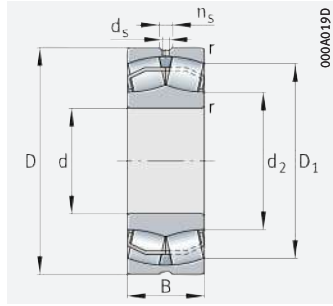

Cylindrical bore

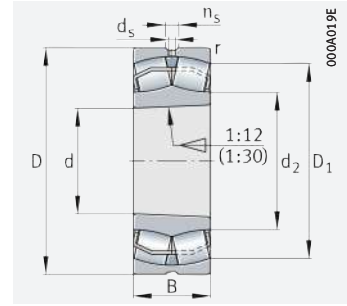

Tapered bore

d = 55 – 75 mm

Main dimensions			Basic load ratings		Fatigue limit load	Limiting speed	Speed rating	Mass	Designation
d	D	B	dyn. C _r	stat. C _{0r}	C _{ur}	n _G	n _{Dr}	m	▶ 681 1.12 ▶ 683 1.13 X-life ▶ 671
			kN	kN	N	min ⁻¹	min ⁻¹	≈ kg	
55	100	25	129	130	17 300	9 000	4 650	0,822	22211-E1-XL
	100	25	129	130	17 300	9 000	4 650	0,825	22211-E1-XL-K
	120	29	160	155	20 200	8 100	5 100	1,28	21311-E1-XL
	120	29	160	155	20 200	8 100	5 100	1,28	21311-E1-XL-K
	120	43	265	260	23 900	5 800	4 500	2,27	22311-E1-XL
	120	43	265	260	23 900	5 800	4 500	2,2	22311-E1-XL-K
60	110	28	160	155	20 200	8 100	4 550	1,12	22212-E1-XL
	110	28	160	155	20 200	8 100	4 550	1,09	22212-E1-XL-K
	130	31	211	226	28 000	6 700	4 100	1,89	21312-E1-XL
	130	31	211	226	28 000	6 700	4 100	1,89	21312-E1-XL-K
	130	46	310	310	28 000	5 400	4 200	2,97	22312-E1-XL
	130	46	310	310	28 000	5 400	4 200	2,8	22312-E1-XL-K
65	120	31	202	210	25 500	7 000	4 200	1,55	22213-E1-XL
	120	31	202	210	25 500	7 000	4 200	1,52	22213-E1-XL-K
	140	33	250	270	33 500	6 200	3 600	2,13	21313-E1-XL
	140	33	250	270	33 500	6 200	3 600	2,13	21313-E1-XL-K
	140	48	350	365	32 500	5 000	3 800	3,57	22313-E1-XL
	140	48	350	365	32 500	5 000	3 800	3,5	22313-E1-XL-K
70	125	31	211	226	28 000	6 700	3 950	1,65	22214-E1-XL
	125	31	211	226	28 000	6 700	3 950	1,61	22214-E1-XL-K
	150	35	250	270	33 500	6 200	3 950	3,13	21314-E1-XL
	150	35	250	270	33 500	6 200	3 950	3,13	21314-E1-XL-K
	150	51	390	390	36 500	4 800	3 700	4,21	22314-E1-XL
	150	51	390	390	36 500	4 800	3 700	4,1	22314-E1-XL-K
75	130	31	216	237	29 500	6 500	3 700	1,72	22215-E1-XL
	130	31	216	237	29 500	6 500	3 700	1,68	22215-E1-XL-K
	160	37	305	325	38 000	5 700	3 750	3,79	21315-E1-XL
	160	37	305	325	38 000	5 700	3 750	3,74	21315-E1-XL-K
	160	55	445	450	40 500	4 500	3 550	5,38	22315-E1-XL
	160	55	445	450	40 500	4 500	3 550	5,3	22315-E1-XL-K

medias ▶ <https://www.schaeffler.de/std/1ECA>

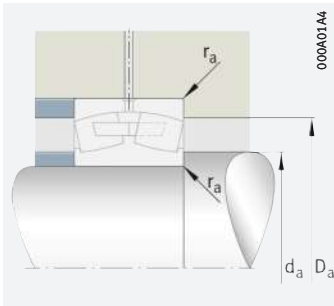

Mounting dimensions

Dimensions						Mounting dimensions			Calculation factors			
d	r	D ₁	d ₂	d _s	n _s	d _a	D _a	r _a	e	Y ₁	Y ₂	Y ₀
	min.	≈	≈			min.	max.	max.				
55	1,5	89,8	67,6	3,2	4,8	64	91	1,5	0,21	3,17	4,72	3,1
	1,5	89,8	67,6	3,2	4,8	64	91	1,5	0,21	3,17	4,72	3,1
	2	98,3	71,6	3,2	6,5	66	109	2	0,23	2,98	4,44	2,92
	2	98,3	71,6	3,2	6,5	66	109	2	0,23	2,98	4,44	2,92
	2	101,4	68,9	3,2	6,5	66	109	2	0,36	1,89	2,81	1,84
	2	101,4	68,9	3,2	6,5	66	109	2	0,36	1,89	2,81	1,84
60	1,5	98,7	71,6	3,2	6,5	69	101	1,5	0,23	2,98	4,44	2,92
	1,5	98,7	71,6	3,2	6,5	69	101	1,5	0,23	2,98	4,44	2,92
	2,1	112,5	84,4	3,2	6,5	72	118	2,1	0,23	2,95	4,4	2,89
	2,1	112,5	84,4	3,2	6,5	72	118	2,1	0,23	2,95	4,4	2,89
	2,1	110,1	74,8	3,2	6,5	72	118	2,1	0,35	1,91	2,85	1,87
	2,1	110,1	74,8	3,2	6,5	72	118	2,1	0,35	1,91	2,85	1,87
65	1,5	107,3	79,1	3,2	6,5	74	111	1,5	0,24	2,81	4,19	2,75
	1,5	107,3	79,1	3,2	6,5	74	111	1,5	0,24	2,81	4,19	2,75
	2,1	126,8	94,9	3,2	6,5	77	128	2,1	0,22	3,14	4,67	3,07
	2,1	126,8	94,9	3,2	6,5	77	128	2,1	0,22	3,14	4,67	3,07
	2,1	119,3	83,2	4,8	9,5	77	128	2,1	0,34	2	2,98	1,96
	2,1	119,3	83,2	4,8	9,5	77	128	2,1	0,34	2	2,98	1,96
70	1,5	112,5	84,4	3,2	6,5	79	116	1,5	0,23	2,95	4,4	2,89
	1,5	112,5	84,4	3,2	6,5	79	116	1,5	0,23	2,95	4,4	2,89
	2,1	126,2	94,9	3,2	6,5	82	138	2,1	0,22	3,14	4,67	3,07
	2,1	126,2	94,9	3,2	6,5	82	138	2,1	0,22	3,14	4,67	3,07
	2,1	128	86,7	4,8	9,5	82	138	2,1	0,34	2	2,98	1,96
	2,1	128	86,7	4,8	9,5	82	138	2,1	0,34	2	2,98	1,96
75	1,5	117,7	89,8	3,2	6,5	84	121	1,5	0,22	3,1	4,62	3,03
	1,5	117,7	89,8	3,2	6,5	84	121	1,5	0,22	3,1	4,62	3,03
	2,1	135,2	99,7	3,2	6,5	87	148	2,1	0,22	3,04	4,53	2,97
	2,1	135,2	99,7	3,2	6,5	87	148	2,1	0,22	3,04	4,53	2,97
	2,1	136,3	92,4	4,8	9,5	87	148	2,1	0,34	1,99	2,96	1,94
	2,1	136,3	92,4	4,8	9,5	87	148	2,1	0,34	1,99	2,96	1,94





Spherical roller bearings

With cylindrical or tapered bore

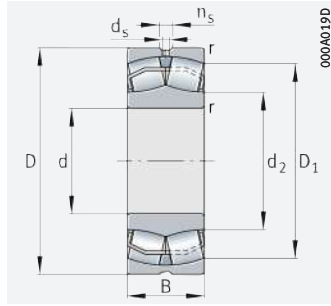

Cylindrical bore

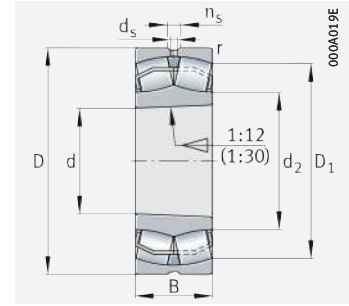

Tapered bore

d = 80 – 95 mm

Main dimensions			Basic load ratings		Fatigue limit load C_{ur}	Limiting speed n_G	Speed rating $n_{\theta r}$	Mass m	Designation
d	D	B	dyn. C_r	stat. C_{0r}					
			kN	kN	N	min^{-1}	min^{-1}	\approx kg	
80	140	33	250	270	33 500	6 200	3 550	2,1	22216-E1-XL
	140	33	250	270	33 500	6 200	3 550	2,08	22216-E1-XL-K
	170	39	305	325	38 000	5 700	4 050	4,54	21316-E1-XL
	170	39	305	325	38 000	5 700	4 050	4,54	21316-E1-XL-K
	170	58	495	510	45 000	4 250	3 400	6,27	22316-E1-XL
	170	58	495	510	45 000	4 250	3 400	6,1	22316-E1-XL-K
85	150	36	305	325	38 000	5 700	3 450	2,65	22217-E1-XL
	150	36	305	325	38 000	5 700	3 450	2,59	22217-E1-XL-K
	180	41	345	375	42 500	5 200	3 800	5,36	21317-E1-XL
	180	41	345	375	42 500	5 200	3 800	5,3	21317-E1-XL-K
	180	60	540	560	49 500	4 100	3 200	7,06	22317-E1-XL
	180	60	540	560	49 500	4 100	3 200	7,1	22317-E1-XL-K
90	160	40	345	375	42 500	5 200	3 400	3,42	22218-E1-XL
	160	40	345	375	42 500	5 200	3 400	3,35	22218-E1-XL-K
	160	52,4	445	520	48 500	4 250	2 650	4,1	23218-E1-XL-K-TVPB
	160	52,4	445	520	48 500	4 250	2 650	4,3	23218-E1-XL-TVPB
	160	52,4	445	520	48 500	4 250	2 650	4,3	23218-E1A-XL-K-M
	160	52,4	445	520	48 500	4 250	2 650	4,5	23218-E1A-XL-M
	190	43	380	415	47 000	4 850	3 600	6,26	21318-E1-XL
	190	43	380	415	47 000	4 850	3 600	6,26	21318-E1-XL-K
	190	64	610	630	55 000	3 850	3 000	8,69	22318-E1-XL
	190	64	610	630	55 000	3 850	3 000	8,5	22318-E1-XL-K
95	170	43	380	415	47 000	4 850	3 300	4,13	22219-E1-XL
	170	43	380	415	47 000	4 850	3 300	4,04	22219-E1-XL-K
	200	45	425	450	47 500	4 600	3 250	6,63	21319-E1-XL-K-TVPB
	200	45	425	450	47 500	4 600	3 250	6,81	21319-E1-XL-TVPB
	200	67	670	700	59 000	3 700	2 800	9,69	22319-E1-XL
	200	67	670	700	59 000	3 700	2 800	9,5	22319-E1-XL-K

medias ► <https://www.schaeffler.de/std/1ECB>

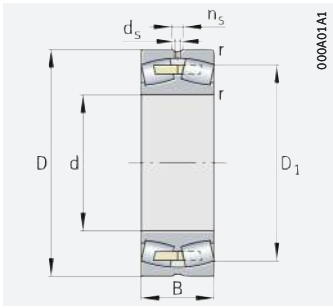

Solid cage, brass or steel;
cylindrical bore

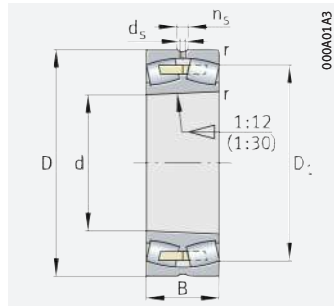

Solid cage, brass or steel;
tapered bore

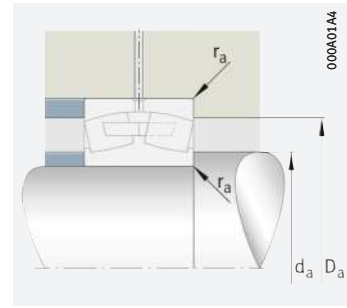

Mounting dimensions

Dimensions						Mounting dimensions			Calculation factors			
d	r	D ₁	d ₂	d _s	n _s	d _a	D _a	r _a	e	Y ₁	Y ₂	Y ₀
	min.	≈	≈			min.	max.	max.				
80	2	126,8	94,9	3,2	6,5	91	129	2	0,22	3,14	4,67	3,07
	2	126,8	94,9	3,2	6,5	91	129	2	0,22	3,14	4,67	3,07
	2,1	135,4	99,7	3,2	6,5	92	158	2,1	0,22	3,04	4,53	2,97
	2,1	135,4	99,8	3,2	6,5	92	158	2,1	0,22	3,04	4,53	2,97
	2,1	145,1	98,3	4,8	9,5	92	158	2,1	0,34	1,99	2,96	1,94
	2,1	145,1	98,3	4,8	9,5	92	158	2,1	0,34	1,99	2,96	1,94
85	2	135,4	99,7	3,2	6,5	96	139	2	0,22	3,04	4,53	2,97
	2	135,4	99,7	3,2	6,5	96	139	2	0,22	3,04	4,53	2,97
	3	143,9	106,1	4,8	9,5	99	166	2,5	0,23	2,9	4,31	2,83
	3	143,9	106,1	4,8	9,5	99	166	2,5	0,23	2,9	4,31	2,83
	3	154,2	104,4	4,8	9,5	99	166	2,5	0,33	2,04	3,04	2
	3	154,2	104,4	4,8	9,5	99	166	2,5	0,33	2,04	3,04	2
90	2	143,9	106,1	3,2	6,5	101	149	2	0,23	2,9	4,31	2,83
	2	143,9	106,1	3,2	6,5	101	149	2	0,23	2,9	4,31	2,83
	2	140	104,1	3,2	6,5	101	149	2	0,31	2,2	3,27	2,15
	2	140	104,1	3,2	6,5	101	149	2	0,31	2,2	3,27	2,15
	2	140	–	3,2	6,5	101	149	2	0,31	2,2	3,27	2,15
	2	140	–	3,2	6,5	101	149	2	0,31	2,2	3,27	2,15
	3	152,7	112,6	4,8	9,5	104	176	2,5	0,24	2,87	4,27	2,8
	3	152,7	112,6	4,8	9,5	104	176	2,5	0,24	2,87	4,27	2,8
	3	162,5	110,2	6,3	12,2	104	176	2,5	0,33	2,03	3,02	1,98
	3	162,5	110,2	6,3	12,2	104	176	2,5	0,33	2,03	3,02	1,98
95	2,1	152,7	112,6	4,8	9,5	107	158	2,1	0,24	2,87	4,27	2,8
	2,1	152,7	112,6	4,8	9,5	107	158	2,1	0,24	2,87	4,27	2,8
	3	169,4	124,3	4,8	9,5	109	186	2,5	0,22	3,04	4,53	2,97
	3	169,4	124,3	4,8	9,5	109	186	2,5	0,22	3,04	4,53	2,97
	3	171,2	116	6,3	12,2	109	186	2,5	0,33	2,03	3,02	1,98
	3	171,2	116	6,3	12,2	109	186	2,5	0,33	2,03	3,02	1,98





Spherical roller bearings

With cylindrical or tapered bore

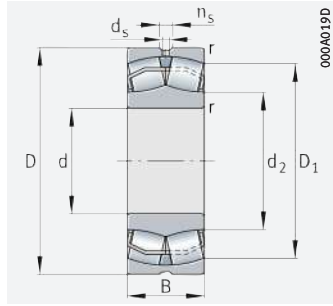

Cylindrical bore

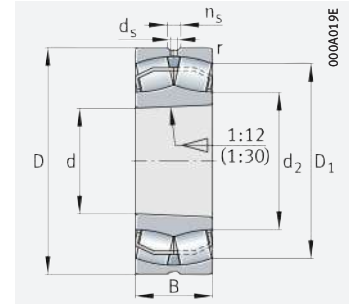

Tapered bore

d = 100 – 100 mm

Main dimensions			Basic load ratings		Fatigue limit load C_{ur}	Limiting speed n_G	Speed rating $n_{\theta r}$	Mass m	Designation
d	D	B	dyn. C_r	stat. C_{0r}					
			kN	kN	N	min^{-1}	min^{-1}	≈ kg	
100	165	52	450	570	52 000	4 000	2 750	4,1	23120-E1-XL-K-TVPB
	165	52	450	570	52 000	4 000	2 750	4,2	23120-E1-XL-TVPB
	165	52	450	570	52 000	4 000	2 750	4,2	23120-E1A-XL-K-M
	165	52	450	570	52 000	4 000	2 750	4,4	23120-E1A-XL-M
	180	46	430	475	52 000	4 550	3 150	4,96	22220-E1-XL
	180	46	430	475	52 000	4 550	3 150	4,91	22220-E1-XL-K
	180	60,3	560	660	60 000	3 750	2 410	6,1	23220-E1-XL-K-TVPB
	180	60,3	560	660	60 000	3 750	2 410	6,3	23220-E1-XL-TVPB
	180	60,3	560	660	60 000	3 750	2 410	6,3	23220-E1A-XL-K-M
	180	60,3	560	660	60 000	3 750	2 410	6,5	23220-E1A-XL-M
	215	47	495	530	60 000	4 400	3 050	8,08	21320-E1-XL-K-TVPB
	215	47	495	530	60 000	4 400	3 050	8,19	21320-E1-XL-TVPB
	215	73	810	920	75 000	3 300	2 380	13,1	22320-E1-XL
	215	73	810	920	75 000	3 300	2 380	13	22320-E1-XL-K

medias > <https://www.schaeffler.de/std/1ECC>

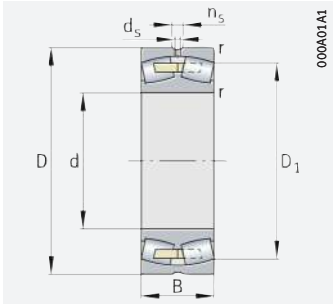

Solid cage, brass or steel;
cylindrical bore

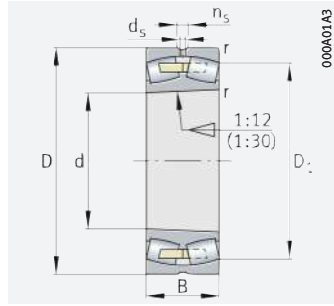

Solid cage, brass or steel;
tapered bore

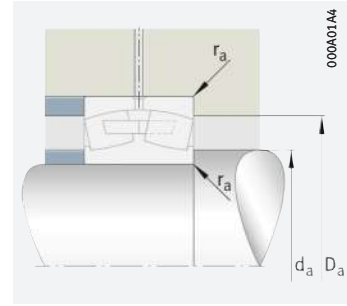

Mounting dimensions

Dimensions						Mounting dimensions			Calculation factors			
d	r	D ₁	d ₂	d _s	n _s	d _a	D _a	r _a	e	Y ₁	Y ₂	Y ₀
	min.	≈	≈			min.	max.	max.				
100	2	146,3	113,9	3,2	6,5	111	154	2	0,28	2,37	3,53	2,32
	2	146,3	113,9	3,2	6,5	111	154	2	0,28	2,37	3,53	2,32
	2	146,3	–	3,2	6,5	111	154	2	0,28	2,37	3,53	2,32
	2	146,3	–	3,2	6,5	111	154	2	0,28	2,37	3,53	2,32
	2,1	161,4	119	4,8	9,5	112	168	2,1	0,24	2,84	4,23	2,78
	2,1	161,4	119	4,8	9,5	112	168	2,1	0,24	2,84	4,23	2,78
	2,1	156,7	116,7	4,8	9,5	112	168	2,1	0,31	2,15	3,2	2,1
	2,1	156,7	116,7	4,8	9,5	112	168	2,1	0,31	2,15	3,2	2,1
	2,1	156,7	–	4,8	9,5	112	168	2,1	0,31	2,15	3,2	2,1
	2,1	156,7	–	4,8	9,5	112	168	2,1	0,31	2,15	3,2	2,1
	3	182	132	4,8	9,5	114	201	2,5	0,22	3,14	4,67	3,07
	3	182	132	4,8	9,5	114	201	2,5	0,22	3,14	4,67	3,07
	3	184,7	130,2	6,3	12,2	114	201	2,5	0,33	2,03	3,02	1,98
	3	184,7	130,2	6,3	12,2	114	201	2,5	0,33	2,03	3,02	1,98





Spherical roller bearings

With cylindrical or tapered bore

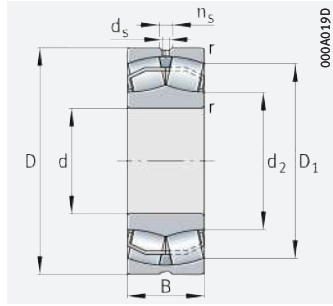

Cylindrical bore

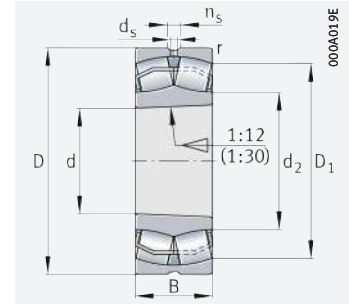

Tapered bore

d = 110 – 110 mm

Main dimensions			Basic load ratings		Fatigue limit load C_{ur}	Limiting speed n_G	Speed rating n_{gr}	Mass m	Designation
d	D	B	dyn. C_r	stat. C_{or}					
			kN	kN	N	min^{-1}	min^{-1}	≈ kg	
110	170	45	400	530	53 000	4 200	3 000	3,4	23022-E1-XL-K-TVPB
	170	45	400	530	53 000	4 200	3 000	3,5	23022-E1-XL-TVPB
	170	45	400	530	53 000	4 200	3 000	3,8	23022-E1A-XL-K-M
	170	45	400	530	53 000	4 200	3 000	3,9	23022-E1A-XL-M
	180	56	530	680	60 000	3 700	2 550	4,9	23122-E1-XL-K-TVPB
	180	56	530	680	60 000	3 700	2 550	5,3	23122-E1-XL-TVPB
	180	56	530	680	60 000	3 700	2 550	5,1	23122-E1A-XL-K-M
	180	56	530	680	60 000	3 700	2 550	5,5	23122-E1A-XL-M
	180	69	530	750	84 000	3 350	1 960	6,8	24122-BE-XL
	180	69	530	750	84 000	3 350	1 960	6,7	24122-BE-XL-K30
	200	53	550	600	62 000	4 100	3 000	6,99	22222-E1-XL
	200	53	550	600	62 000	4 100	3 000	6,99	22222-E1-XL-K
	200	69,8	710	870	71 000	3 250	2 100	8,8	23222-E1-XL-K-TVPB
	200	69,8	710	870	71 000	3 250	2 100	9,2	23222-E1-XL-TVPB
	200	69,8	710	870	71 000	3 250	2 100	9,3	23222-E1A-XL-K-M
	200	69,8	710	870	71 000	3 250	2 100	9,5	23222-E1A-XL-M
	240	50	600	640	69 000	4 000	2 700	10,91	21322-E1-XL-K-TVPB
	240	50	600	640	69 000	4 000	2 700	11,06	21322-E1-XL-TVPB
240	80	950	1 070	90 000	3 000	2 130	17,7	22322-E1-XL	
240	80	950	1 070	90 000	3 000	2 130	17,4	22322-E1-XL-K	

medias ► <https://www.schaeffler.de/std/1ECD>

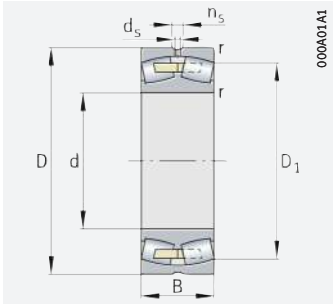

Solid cage, brass or steel;
cylindrical bore

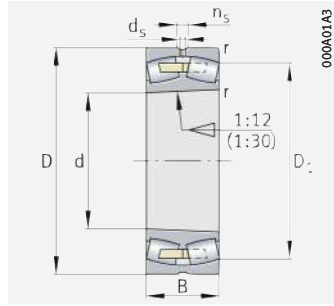

Solid cage, brass or steel;
tapered bore

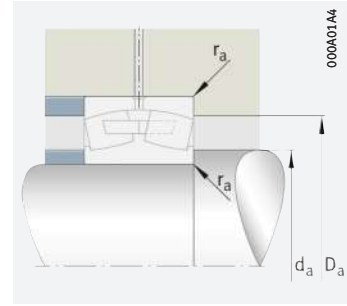

Mounting dimensions

Dimensions						Mounting dimensions			Calculation factors			
d	r	D ₁	d ₂	d _s	n _s	d _a	D _a	r _a	e	Y ₁	Y ₂	Y ₀
	min.	≈	≈			min.	max.	max.				
110	2	154,6	123,7	3,2	6,5	118,8	161,2	2	0,23	2,9	4,31	2,83
	2	154,6	123,7	3,2	6,5	118,8	161,2	2	0,23	2,9	4,31	2,83
	2	154,6	–	3,2	6,5	118,8	161,2	2	0,23	2,9	4,31	2,83
	2	154,6	–	3,2	6,5	118,8	161,2	2	0,23	2,9	4,31	2,83
	2	160	124,6	4,8	9,5	121	169	2	0,28	2,39	3,56	2,34
	2	160	124,6	4,8	9,5	121	169	2	0,28	2,39	3,56	2,34
	2	160	–	4,8	9,5	121	169	2	0,28	2,41	3,59	2,35
	2	160	–	4,8	9,5	121	169	2	0,28	2,41	3,59	2,35
	2	154,9	125,6	3,2	6,5	121	169	2	0,34	1,96	2,92	1,92
	2	154,9	125,6	3,2	6,5	121	169	2	0,34	1,96	2,92	1,92
	2,1	178,7	129,4	4,8	9,5	122	188	2,1	0,25	2,71	4,04	2,65
	2,1	178,7	129,4	4,8	9,5	122	188	2,1	0,25	2,71	4,04	2,65
	2,1	172,7	129,1	4,8	9,5	122	188	2,1	0,33	2,06	3,06	2,01
	2,1	172,7	129,1	4,8	9,5	122	188	2,1	0,33	2,06	3,06	2,01
	2,1	172,7	–	4,8	9,5	122	188	2,1	0,33	2,06	3,06	2,01
	2,1	172,7	–	4,8	9,5	122	188	2,1	0,33	2,06	3,06	2,01
	3	202,5	146,4	6,3	12,2	124	226	2,5	0,21	3,24	4,82	3,16
	3	202,5	146,4	6,3	12,2	124	226	2,5	0,21	3,24	4,82	3,16
	3	204,9	143,1	8	15	124	226	2,5	0,33	2,07	3,09	2,03
	3	204,9	143,1	8	15	124	226	2,5	0,33	2,07	3,09	2,03





Spherical roller bearings

With cylindrical or tapered bore

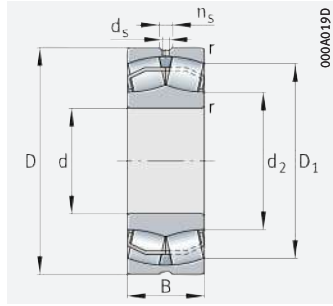

Cylindrical bore

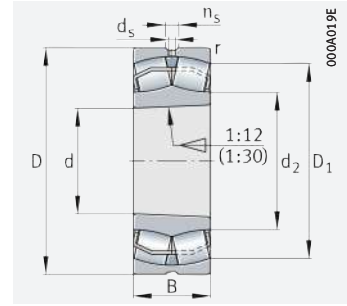

Tapered bore

d = 120 – 120 mm

Main dimensions			Basic load ratings		Fatigue limit load	Limiting speed	Speed rating	Mass	Designation
d	D	B	dyn. C _r	stat. C _{0r}	C _{ur}	n _G	n _{Dr}	m	▶ 681 1.12 ▶ 683 1.13 X-life ▶ 671
			kN	kN	N	min ⁻¹	min ⁻¹	≈ kg	
120	180	46	430	580	58 000	3 950	2 800	3,7	23024-E1-XL-K-TVPB
	180	46	430	580	58 000	3 950	2 800	3,9	23024-E1-XL-TVPB
	180	46	430	580	58 000	3 950	2 800	4,1	23024-E1A-XL-K-M
	180	46	430	580	58 000	3 950	2 800	4,2	23024-E1A-XL-M
	180	60	450	690	84 000	3 450	2 360	5,6	24024-BE-XL
	180	60	450	690	84 000	3 450	2 360	5,4	24024-BE-XL-K30
	200	62	630	800	72 000	3 400	2 290	7,1	23124-E1-XL-K-TVPB
	200	62	630	800	72 000	3 400	2 290	7,4	23124-E1-XL-TVPB
	200	62	630	800	72 000	3 400	2 290	7,6	23124-E1A-XL-K-M
	200	62	630	800	72 000	3 400	2 290	7,7	23124-E1A-XL-M
	200	80	680	950	101 000	2 950	1 740	10,4	24124-BE-XL
	200	80	680	950	101 000	2 950	1 740	10,2	24124-BE-XL-K30
	215	58	640	740	71 000	3 650	2 700	8,84	22224-E1-XL
	215	58	640	740	68 000	3 650	2 700	8,84	22224-E1-XL-K
	215	76	820	1 020	80 000	3 000	1 910	11,1	23224-E1-XL-K-TVPB
	215	76	820	1 020	80 000	3 000	1 910	11,5	23224-E1-XL-TVPB
	215	76	820	1 020	80 000	3 000	1 910	11,4	23224-E1A-XL-K-M
	215	76	820	1 020	80 000	3 000	1 910	12,1	23224-E1A-XL-M
260	86	1 080	1 170	102 000	2 850	2 000	22,3	22324-E1-XL	
260	86	1 080	1 170	102 000	2 850	2 000	22,1	22324-E1-XL-K	

medias ▶ <https://www.schaeffler.de/std/1ECE>

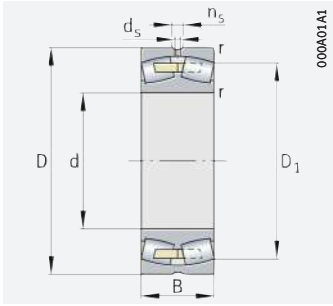

Solid cage, brass or steel;
cylindrical bore

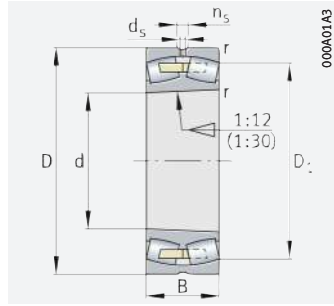

Solid cage, brass or steel;
tapered bore

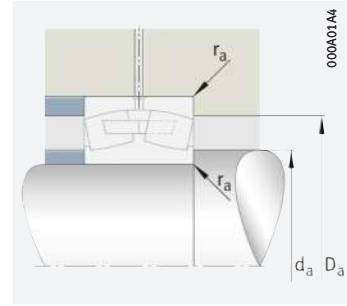

Mounting dimensions

Dimensions

Mounting dimensions

Calculation factors

d	r	D ₁	d ₂	d _s	n _s	d _a	D _a	r _a	e	Y ₁	Y ₂	Y ₀
120	2	164,7	133	3,2	6,5	128,8	171,2	2	0,22	3,04	4,53	2,97
	2	164,7	133	3,2	6,5	128,8	171,2	2	0,22	3,04	4,53	2,97
	2	164,7	–	3,2	6,5	128,8	171,2	2	0,22	3,04	4,53	2,97
	2	164,7	–	3,2	6,5	128,8	171,2	2	0,22	3,04	4,53	2,97
	2	159,8	134,5	3,2	6,5	128,8	171,2	2	0,29	2,33	3,47	2,28
	2	159,8	134,5	3,2	6,5	128,8	171,2	2	0,29	2,33	3,47	2,28
	2	177,4	136,2	4,8	9,5	131	189	2	0,28	2,39	3,56	2,34
	2	177,4	136,2	4,8	9,5	131	189	2	0,28	2,39	3,56	2,34
	2	177,4	–	4,8	9,5	131	189	2	0,28	2,39	3,56	2,34
	2	177,4	–	4,8	9,5	131	189	2	0,28	2,39	3,56	2,34
	2	170,3	136,6	3,2	6,5	131	189	2	0,37	1,84	2,74	1,8
	2	170,3	136,6	3,2	6,5	131	189	2	0,37	1,84	2,74	1,8
	2,1	192	141,9	6,3	12,2	132	203	2,1	0,25	2,71	4,04	2,65
	2,1	192	141,9	6,3	12,2	132	203	2,1	0,25	2,71	4,04	2,65
	2,1	185,5	139	4,8	9,5	132	203	2,1	0,33	2,03	3,02	1,98
	2,1	185,5	139	4,8	9,5	132	203	2,1	0,33	2,03	3,02	1,98
	2,1	185,5	–	4,8	9,5	132	203	2,1	0,33	2,03	3,02	1,98
	2,1	185,5	–	4,8	9,5	132	203	2,1	0,33	2,03	3,02	1,98
	3	222,4	150,8	8	15	134	246	2,5	0,33	2,06	3,06	2,01
	3	222,4	150,7	8	15	134	246	2,5	0,33	2,06	3,06	2,01





Spherical roller bearings

With cylindrical or tapered bore

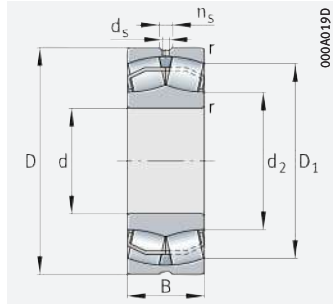

Cylindrical bore

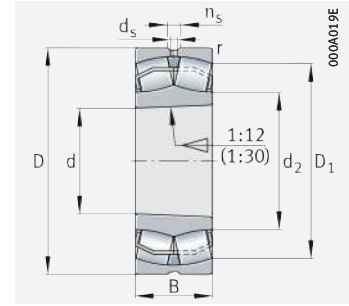

Tapered bore

d = 130 – 130 mm

Main dimensions			Basic load ratings		Fatigue limit load	Limiting speed	Speed rating	Mass	Designation
d	D	B	dyn. C _r	stat. C _{0r}	C _{ur}	n _G	n _{0r}	m	▶ 681 1.12 ▶ 683 1.13 X-life ▶ 671
			kN	kN	N	min ⁻¹	min ⁻¹	≈ kg	
130	200	52	540	730	69 000	3 600	2 600	5,4	23026-E1-XL-K-TVPB
	200	52	540	730	69 000	3 600	2 600	5,6	23026-E1-XL-TVPB
	200	52	540	730	69 000	3 600	2 600	5,7	23026-E1A-XL-K-M
	200	52	540	730	69 000	3 600	2 600	6	23026-E1A-XL-M
	200	69	570	860	100 000	3 100	2 130	8,4	24026-BE-XL
	200	69	570	860	100 000	3 100	2 130	8,1	24026-BE-XL-K30
	210	64	680	890	78 000	3 200	2 110	7,8	23126-E1-XL-K-TVPB
	210	64	680	890	78 000	3 200	2 110	8,1	23126-E1-XL-TVPB
	210	64	680	890	78 000	3 200	2 110	8,1	23126-E1A-XL-K-M
	210	64	680	890	78 000	3 200	2 110	8,5	23126-E1A-XL-M
	210	80	710	1 050	109 000	2 800	1 560	11	24126-BE-XL
	210	80	710	1 050	109 000	2 800	1 560	10,8	24126-BE-XL-K30
	230	64	760	890	79 000	3 350	2 500	11,1	22226-E1-XL
	230	64	760	890	79 000	3 350	2 500	10,9	22226-E1-XL-K
	230	80	910	1 150	88 000	2 850	1 740	12,6	23226-E1-XL-K-TVPB
	230	80	910	1 150	88 000	2 850	1 740	13,4	23226-E1-XL-TVPB
	230	80	910	1 150	88 000	2 850	1 740	13,6	23226-E1A-XL-K-M
	230	80	910	1 150	88 000	2 850	1 740	14	23226-E1A-XL-M
280	93	1 250	1 370	116 000	2 650	1 820	28	22326-E1-XL	
280	93	1 250	1 370	116 000	2 650	1 820	27,4	22326-E1-XL-K	

medias ▶ <https://www.schaeffler.de/std/1ECF>

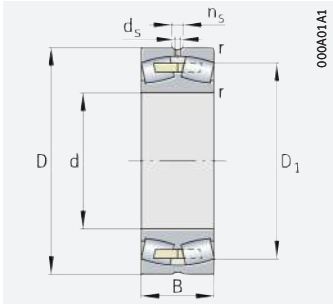

Solid cage, brass or steel;
cylindrical bore

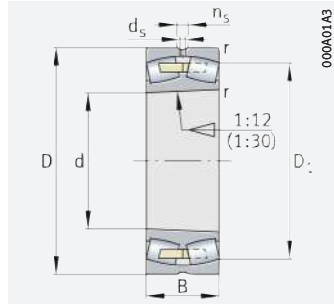

Solid cage, brass or steel;
tapered bore

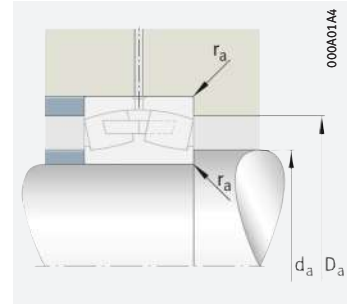

Mounting dimensions

Dimensions

Mounting dimensions

Calculation factors

d	r	D ₁	d ₂	d _s	n _s	d _a	D _a	r _a	e	Y ₁	Y ₂	Y ₀
130	2	182,3	145,9	4,8	9,5	138,8	191,2	2	0,23	2,95	4,4	2,89
	2	182,3	145,9	4,8	9,5	138,8	191,2	2	0,23	2,95	4,4	2,89
	2	182,3	–	4,8	9,5	138,8	191,2	2	0,23	2,95	4,4	2,89
	2	182,3	–	4,8	9,5	138,8	191,2	2	0,23	2,95	4,4	2,89
	2	176,1	146,2	3,2	6,5	138,8	191,2	2	0,31	2,21	3,29	2,16
	2	176,1	146,2	3,2	6,5	138,8	191,2	2	0,31	2,21	3,29	2,16
	2	187,3	146	4,8	9,5	141	199	2	0,28	2,45	3,64	2,39
	2	187,3	146	4,8	9,5	141	199	2	0,28	2,45	3,64	2,39
	2	187,3	–	4,8	9,5	141	199	2	0,28	2,45	3,64	2,39
	2	187,3	–	4,8	9,5	141	199	2	0,28	2,45	3,64	2,39
	2	181,2	148,3	3,2	6,5	141	199	2	0,34	1,98	2,94	1,93
	2	181,2	148,3	3,2	6,5	141	199	2	0,34	1,98	2,94	1,93
	3	205	151,7	6,3	12,2	144	216	2,5	0,26	2,62	3,9	2,56
	3	205	151,7	6,3	12,2	144	216	2,5	0,26	2,62	3,9	2,56
	3	199,3	150	4,8	9,5	144	216	2,5	0,33	2,07	3,09	2,03
	3	199,3	150	4,8	9,5	144	216	2,5	0,33	2,07	3,09	2,03
	3	199,3	–	4,8	9,5	144	216	2,5	0,33	2,07	3,09	2,03
	3	199,3	–	4,8	9,5	144	216	2,5	0,33	2,07	3,09	2,03
4	239,5	162,2	9,5	17,7	147	263	3	0,33	2,06	3,06	2,01	
4	239,5	162,2	9,5	17,7	147	263	3	0,33	2,06	3,06	2,01	





Spherical roller bearings

With cylindrical or tapered bore

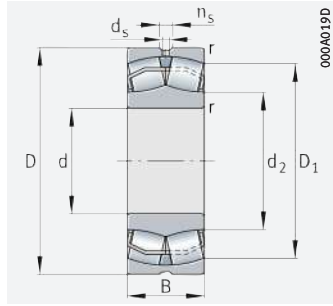

Cylindrical bore

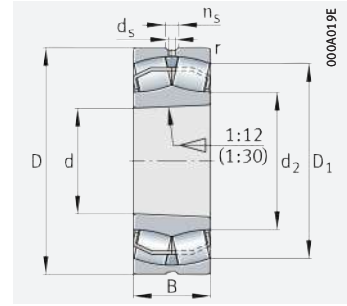

Tapered bore

d = 140 – 140 mm

Main dimensions			Basic load ratings		Fatigue limit load	Limiting speed	Speed rating	Mass	Designation
d	D	B	dyn. C _r	stat. C _{0r}	C _{ur}	n _G	n _{∅r}	m	▶ 681 1.12 ▶ 683 1.13 X-life ▶ 671
			kN	kN	N	min ⁻¹	min ⁻¹	≈ kg	
140	210	53	570	800	75 000	3 450	2 390	5,8	23028-E1-XL-K-TVPB
	210	53	570	800	75 000	3 450	2 390	6	23028-E1-XL-TVPB
	210	53	570	800	75 000	3 450	2 390	6	23028-E1A-XL-K-M
	210	53	570	800	75 000	3 450	2 390	6,5	23028-E1A-XL-M
	210	69	590	930	108 000	2 950	1 950	8,4	24028-BE-XL
	210	69	590	930	108 000	2 950	1 950	8,1	24028-BE-XL-K30
	225	68	760	1 010	87 000	3 000	1 930	9,5	23128-E1-XL-K-TVPB
	225	68	760	1 010	87 000	3 000	1 930	9,8	23128-E1-XL-TVPB
	225	68	760	1 010	87 000	3 000	1 930	10,2	23128-E1A-XL-K-M
	225	68	760	1 010	87 000	3 000	1 930	10,4	23128-E1A-XL-M
	225	85	800	1 190	124 000	2 650	1 430	13,8	24128-BE-XL
	225	85	800	1 190	124 000	2 650	1 430	13,5	24128-BE-XL-K30
	250	68	870	1 040	97 000	3 150	2 250	14,1	22228-E1-XL
	250	68	870	1 040	97 000	3 150	2 250	13,7	22228-E1-XL-K
	250	88	1 090	1 400	113 000	2 600	1 550	17,1	23228-E1-XL-K-TVPB
	250	88	1 090	1 400	113 000	2 600	1 550	17,1	23228-E1-XL-TVPB
	250	88	1 090	1 400	113 000	2 600	1 550	17,6	23228-E1A-XL-K-M
	250	88	1 090	1 400	113 000	2 600	1 550	18,3	23228-E1A-XL-M
	300	102	1 460	1 630	131 000	2 420	1 660	34,6	22328-E1-XL
	300	102	1 460	1 630	131 000	2 420	1 660	34,4	22328-E1-XL-K

medias ▶ <https://www.schaeffler.de/std/1ED0>

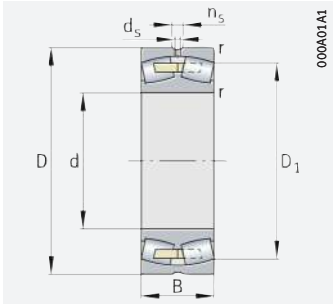

Solid cage, brass or steel;
cylindrical bore

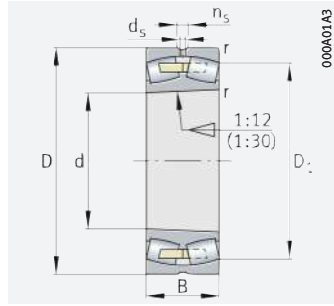

Solid cage, brass or steel;
tapered bore

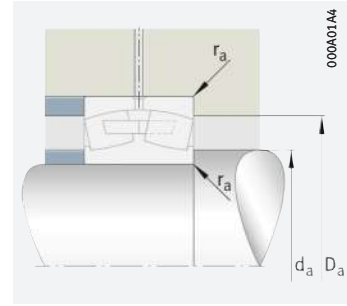

Mounting dimensions

Dimensions

Mounting dimensions

Calculation factors

d	r	D ₁	d ₂	d _s	n _s	d _a	D _a	r _a	e	Y ₁	Y ₂	Y ₀
						min.	max.	max.				
140	2	192,3	155,4	4,8	9,5	148,8	201,2	2	0,22	3,07	4,57	3
	2	192,3	155,4	4,8	9,5	148,8	201,2	2	0,22	3,07	4,57	3
	2	192,3	–	4,8	9,5	148,8	201,2	2	0,22	3,07	4,57	3
	2	192,3	–	4,8	9,5	148,8	201,2	2	0,22	3,07	4,57	3
	2	186,4	157,1	3,2	6,5	148,8	201,2	2	0,28	2,37	3,53	2,32
	2	186,4	157,1	3,2	6,5	148,8	201,2	2	0,28	2,37	3,53	2,32
	2,1	201	157,1	4,8	9,5	152	213	2,1	0,27	2,49	3,71	2,43
	2,1	201	157,1	4,8	9,5	152	213	2,1	0,27	2,49	3,71	2,43
	2,1	201	–	4,8	9,5	152	213	2,1	0,27	2,49	3,71	2,43
	2,1	201	–	4,8	9,5	152	213	2,1	0,27	2,49	3,71	2,43
	2,1	194,4	158,9	4,8	9,5	152	213	2,1	0,34	1,99	2,96	1,94
	2,1	194,4	158,9	4,8	9,5	152	213	2,1	0,34	1,99	2,96	1,94
	3	223,1	164,9	6,3	12,2	154	236	2,5	0,25	2,67	3,97	2,61
	3	223,1	164,9	6,3	12,2	154	236	2,5	0,25	2,67	3,97	2,61
	3	216	162	6,3	12,2	154	236	2,5	0,33	2,04	3,04	2
	3	216	162	6,3	12,2	154	236	2,5	0,33	2,04	3,04	2
	3	216	–	6,3	12,2	154	236	2,5	0,33	2,04	3,04	2
	3	216	–	6,3	12,2	154	236	2,5	0,33	2,04	3,04	2
4	255,7	173,5	9,5	17,7	157	283	3	0,34	2	2,98	1,96	
4	255,7	173,5	9,5	17,7	157	283	3	0,34	2	2,98	1,96	





Spherical roller bearings

With cylindrical or tapered bore

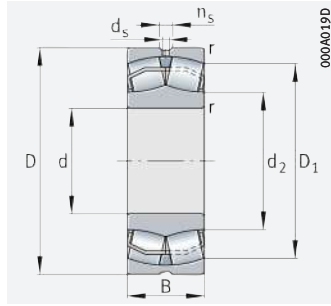

Cylindrical bore

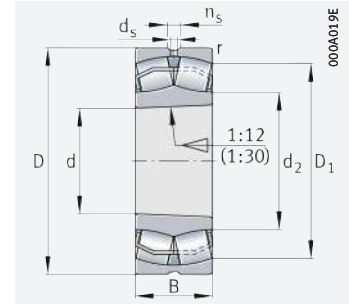

Tapered bore

d = 150 – 150 mm

Main dimensions			Basic load ratings		Fatigue limit load	Limiting speed	Speed rating	Mass	Designation
d	D	B	dyn. C _r	stat. C _{0r}	C _{ur}	n _G	n _{∅r}	m	▶ 681 1.12 ▶ 683 1.13 X-life ▶ 671
			kN	kN	N	min ⁻¹	min ⁻¹	≈ kg	
150	225	56	630	880	85 000	3 250	2 210	7,3	23030-E1-XL-K-TVPB
	225	56	630	880	85 000	3 250	2 210	7,6	23030-E1-XL-TVPB
	225	56	630	880	85 000	3 250	2 210	7,3	23030-E1A-XL-K-M
	225	56	630	880	85 000	3 250	2 210	7,8	23030-E1A-XL-M
	225	75	680	1 090	122 000	2 750	1 790	11,1	24030-BE-XL
	225	75	680	1 090	122 000	2 750	1 790	10,7	24030-BE-XL-K30
	250	80	1 000	1 330	141 000	2 650	1 720	14,5	23130-E1-XL-K-TVPB
	250	80	1 000	1 330	141 000	2 650	1 720	15	23130-E1-XL-TVPB
	250	80	1 000	1 330	141 000	2 650	1 720	15,8	23130-E1A-XL-K-M
	250	80	1 000	1 330	141 000	2 650	1 720	16,3	23130-E1A-XL-M
	250	100	1 050	1 520	148 000	2 370	1 270	20,6	24130-BE-XL
	250	100	1 050	1 520	148 000	2 370	1 270	20,2	24130-BE-XL-K30
	270	73	1 010	1 210	111 000	2 900	2 050	18,2	22230-E1-XL
	270	73	1 010	1 210	111 000	2 900	2 050	17,8	22230-E1-XL-K
	270	96	1 280	1 660	129 000	2 400	1 400	22,3	23230-E1-XL-K-TVPB
	270	96	1 280	1 660	129 000	2 400	1 400	22,9	23230-E1-XL-TVPB
	270	96	1 280	1 660	129 000	2 400	1 400	22,9	23230-E1A-XL-K-M
	270	96	1 280	1 660	129 000	2 400	1 400	23,8	23230-E1A-XL-M
320	108	1 640	1 850	147 000	2 290	1 520	42,2	22330-E1-XL	
320	108	1 640	1 850	147 000	2 290	1 520	40,9	22330-E1-XL-K	

medias ▶ <https://www.schaeffler.de/std/1ED1>

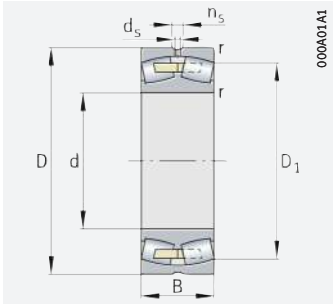

Solid cage, brass or steel;
cylindrical bore

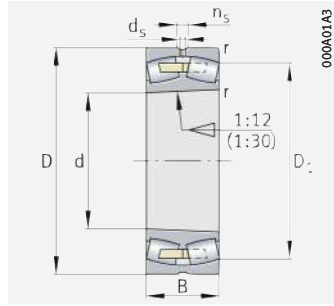

Solid cage, brass or steel;
tapered bore

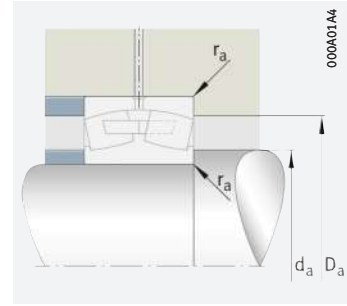

Mounting dimensions

Dimensions						Mounting dimensions			Calculation factors			
d	r	D ₁	d ₂	d _s	n _s	d _a	D _a	r _a	e	Y ₁	Y ₂	Y ₀
	min.	≈	≈			min.	max.	max.				
150	2,1	206,3	166,6	4,8	9,5	160,2	214,8	2,1	0,22	3,1	4,62	3,03
	2,1	206,3	166,6	4,8	9,5	160,2	214,8	2,1	0,22	3,1	4,62	3,03
	2,1	206,3	–	4,8	9,5	160,2	214,8	2,1	0,22	3,1	4,62	3,03
	2,1	206,3	–	4,8	9,5	160,2	214,8	2,1	0,22	3,1	4,62	3,03
	2,1	199,4	168,1	3,2	6,5	160,2	214,8	2,1	0,29	2,32	3,45	2,26
	2,1	199,4	168,1	3,2	6,5	160,2	214,8	2,1	0,29	2,32	3,45	2,26
	2,1	220,8	170,1	6,3	12,2	162	238	2,1	0,29	2,32	3,45	2,26
	2,1	220,8	170,2	6,3	12,2	162	238	2,1	0,29	2,32	3,45	2,26
	2,1	220,8	–	6,3	12,2	162	238	2,1	0,29	2,32	3,45	2,26
	2,1	220,8	–	6,3	12,2	162	238	2,1	0,29	2,32	3,45	2,26
	2,1	213	170,3	4,8	9,5	162	238	2,1	0,37	1,83	2,72	1,79
	2,1	213	170,3	4,8	9,5	162	238	2,1	0,37	1,83	2,72	1,79
	3	240,8	177,9	8	15	164	256	2,5	0,25	2,69	4	2,63
	3	240,8	177,9	8	15	164	256	2,5	0,25	2,69	4	2,63
	3	232,6	174	6,3	12,2	164	256	2,5	0,33	2,02	3	1,97
	3	232,6	174	6,3	12,2	164	256	2,5	0,33	2,02	3	1,97
	3	232,6	–	6,3	12,2	164	256	2,5	0,33	2,02	3	1,97
	3	232,6	–	6,3	12,2	164	256	2,5	0,33	2,02	3	1,97
4	273,2	185,3	9,5	17,7	167	303	3	0,33	2,02	3	1,97	
4	273,2	185,3	9,5	17,7	167	303	3	0,33	2,02	3	1,97	





Spherical roller bearings

With cylindrical or tapered bore

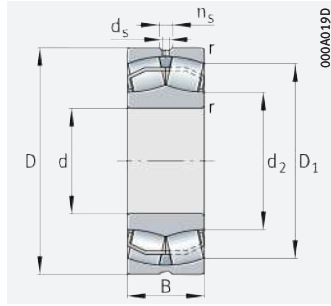

Cylindrical bore

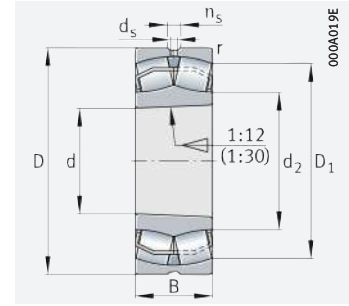

Tapered bore

d = 160 – 160 mm

Main dimensions			Basic load ratings		Fatigue limit load	Limiting speed	Speed rating	Mass	Designation
d	D	B	dyn. C _r	stat. C _{0r}	C _{ur}	n _G	n _{∅r}	m	▶ 681 1.12 ▶ 683 1.13 X-life ▶ 671
			kN	kN	N	min ⁻¹	min ⁻¹	≈ kg	
160	240	60	720	1 010	95 000	3 050	2 060	8,7	23032-E1-XL-K-TVPB
	240	60	720	1 010	95 000	3 050	2 060	9	23032-E1-XL-TVPB
	240	60	720	1 010	95 000	3 050	2 060	9,4	23032-E1A-XL-K-M
	240	60	720	1 010	95 000	3 050	2 060	9,5	23032-E1A-XL-M
	240	80	770	1 240	1 370	137 000	2 550	12,7	24032-BE-XL
	240	80	770	1 240	1 370	137 000	2 550	12,2	24032-BE-XL-K30
	270	86	1 160	1 550	162 000	2 490	1 560	18,5	23132-E1-XL-K-TVPB
	270	86	1 160	1 550	162 000	2 490	1 560	19,1	23132-E1-XL-TVPB
	270	86	1 160	1 550	162 000	2 490	1 560	18,6	23132-E1A-XL-K-M
	270	86	1 160	1 550	162 000	2 490	1 560	20	23132-E1A-XL-M
	270	109	1 220	1 800	168 000	2 180	1 140	25,4	24132-BE-XL
	270	109	1 220	1 800	168 000	2 180	1 140	24,9	24132-BE-XL-K30
	290	80	1 150	1 400	125 000	2 650	1 900	23,3	22232-E1-XL
	290	80	1 150	1 400	125 000	2 650	1 900	22,4	22232-E1-XL-K
	290	104	1 460	1 910	146 000	2 210	1 280	27,7	23232-E1-XL-K-TVPB
	290	104	1 460	1 910	146 000	2 210	1 280	28,6	23232-E1-XL-TVPB
	290	104	1 460	1 910	146 000	2 210	1 280	28,5	23232-E1A-XL-K-M
	290	104	1 460	1 910	146 000	2 210	1 280	29,8	23232-E1A-XL-M
	340	114	1 680	1 990	157 000	2 250	1 420	48,4	22332-BE-XL
	340	114	1 680	1 990	157 000	2 250	1 420	47,3	22332-BE-XL-K

medias ▶ <https://www.schaeffler.de/std/1ED2>

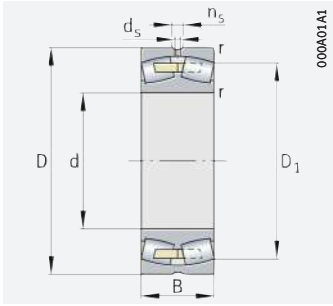

Solid cage, brass or steel;
cylindrical bore

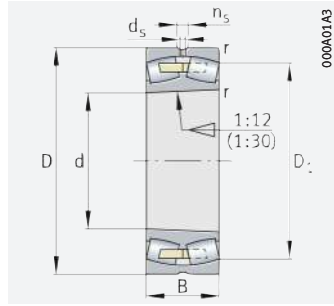

Solid cage, brass or steel;
tapered bore

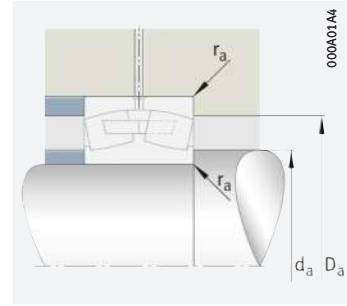

Mounting dimensions

Dimensions						Mounting dimensions			Calculation factors			
d	r	D ₁	d ₂	d _s	n _s	d _a	D _a	r _a	e	Y ₁	Y ₂	Y ₀
	min.	≈	≈			min.	max.	max.				
160	2,1	219,9	177	6,3	12,2	170,2	229,8	2,1	0,22	3,1	4,62	3,03
	2,1	219,9	177,5	6,3	12,2	170,2	229,8	2,1	0,22	3,1	4,62	3,03
	2,1	219,9	–	6,3	12,2	170,2	229,8	2,1	0,22	3,1	4,62	3,03
	2,1	219,9	–	6,3	12,2	170,2	229,8	2,1	0,22	3,1	4,62	3,03
	2,1	212,5	179,3	4,8	9,5	170,2	229,8	2,1	0,29	2,32	3,45	2,26
	2,1	212,5	179,3	4,8	9,5	170,2	229,8	2,1	0,29	2,32	3,45	2,26
	2,1	238,3	183,2	8	15	172	258	2,1	0,29	2,32	3,45	2,26
	2,1	238,3	183,2	8	15	172	258	2,1	0,29	2,32	3,45	2,26
	2,1	238,3	–	8	15	172	258	2,1	0,29	2,32	3,45	2,26
	2,1	238,3	–	8	15	172	258	2,1	0,29	2,32	3,45	2,26
	2,1	228,9	183,4	4,8	9,5	172	258	2,1	0,37	1,8	2,69	1,76
	2,1	228,9	183,4	4,8	9,5	172	258	2,1	0,37	1,8	2,69	1,76
	3	258,2	190,9	8	15	174	276	2,5	0,26	2,64	3,93	2,58
	3	258,2	190,9	8	15	174	276	2,5	0,26	2,64	3,93	2,58
	3	249,3	186,7	8	15	174	276	2,5	0,34	2	2,98	1,96
	3	249,3	186,7	8	15	174	276	2,5	0,34	2	2,98	1,96
	3	249,3	–	8	15	174	276	2,5	0,34	2	2,98	1,96
	3	249,3	–	8	15	174	276	2,5	0,34	2	2,98	1,96
4	286,7	201,2	9,5	17,7	177	323	3	0,35	1,94	2,88	1,89	
4	286,7	201,2	9,5	17,7	177	323	3	0,35	1,94	2,88	1,89	





Spherical roller bearings

With cylindrical or tapered bore

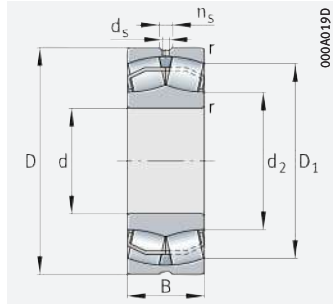

Cylindrical bore

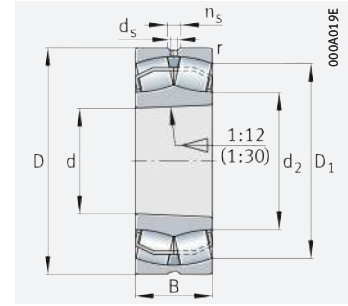

Tapered bore

d = 170 – 170 mm

Main dimensions			Basic load ratings		Fatigue limit load	Limiting speed	Speed rating	Mass	Designation
d	D	B	dyn. C _r	stat. C _{0r}	C _{ur}	n _G	n _{∅r}	m	▶ 681 1.12 ▶ 683 1.13 X-life ▶ 671
			kN	kN	N	min ⁻¹	min ⁻¹	≈ kg	
170	260	67	880	1 230	148 000	2 800	1 890	11,9	23034-E1-XL-K-TVPB
	260	67	880	1 230	148 000	2 800	1 890	12,3	23034-E1-XL-TVPB
	260	67	880	1 230	148 000	2 800	1 890	12,5	23034-E1A-XL-K-M
	260	67	880	1 230	148 000	2 800	1 890	12,8	23034-E1A-XL-M
	260	90	940	1 480	158 000	2 380	1 540	17,2	24034-BE-XL
	260	90	940	1 480	158 000	2 380	1 540	16,5	24034-BE-XL-K30
	280	88	1 220	1 690	173 000	2 380	1 460	19,9	23134-E1-XL-K-TVPB
	280	88	1 220	1 690	173 000	2 380	1 460	20,7	23134-E1-XL-TVPB
	280	88	1 220	1 690	173 000	2 380	1 460	19,5	23134-E1A-XL-K-M
	280	88	1 220	1 690	173 000	2 380	1 460	22,1	23134-E1A-XL-M
	280	109	1 260	1 900	179 000	2 110	1 060	26,4	24134-BE-XL
	280	109	1 260	1 900	179 000	2 110	1 060	25,9	24134-BE-XL-K30
	310	86	1 320	1 570	140 000	2 550	1 780	27,8	22234-E1-XL
	310	86	1 320	1 570	140 000	2 550	1 780	27,1	22234-E1-XL-K
	310	110	1 640	2 170	163 000	2 090	1 160	33,1	23234-E1-XL-K-TVPB
	310	110	1 640	2 170	163 000	2 090	1 160	34,9	23234-E1-XL-TVPB
	310	110	1 640	2 170	163 000	2 090	1 160	34,6	23234-E1A-XL-K-M
	310	110	1 640	2 170	163 000	2 090	1 160	35,7	23234-E1A-XL-M
	360	120	1 870	2 220	173 000	2 130	1 320	58,2	22334-BE-XL
	360	120	1 870	2 220	173 000	2 130	1 320	56,9	22334-BE-XL-K

medias ▶ <https://www.schaeffler.de/std/1ED3>

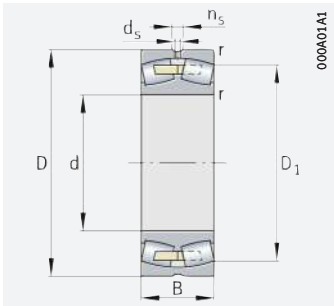

Solid cage, brass or steel;
cylindrical bore

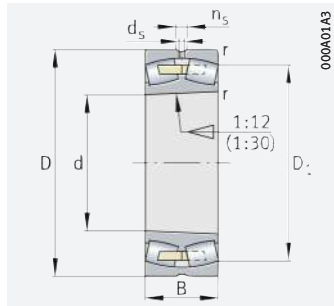

Solid cage, brass or steel;
tapered bore

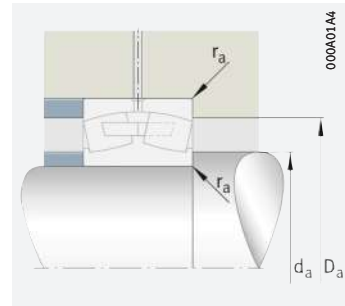

Mounting dimensions

Dimensions						Mounting dimensions			Calculation factors			
d	r	D ₁	d ₂	d _s	n _s	d _a	D _a	r _a	e	Y ₁	Y ₂	Y ₀
	min.	≈	≈			min.	max.	max.				
170	2,1	237,2	189,8	6,3	12,2	180,2	249,8	2,1	0,23	2,98	4,44	2,92
	2,1	237,2	189,8	6,3	12,2	180,2	249,8	2,1	0,23	2,98	4,44	2,92
	2,1	237,2	–	6,3	12,2	180,2	249,8	2,1	0,23	2,98	4,44	2,92
	2,1	237,2	–	6,3	12,2	180,2	249,8	2,1	0,23	2,98	4,44	2,92
	2,1	228,4	190	4,8	9,5	180,2	249,8	2,1	0,31	2,2	3,27	2,15
	2,1	228,4	190	4,8	9,5	180,2	249,8	2,1	0,31	2,2	3,27	2,15
	2,1	248,1	193,4	8	15	182	268	2,1	0,28	2,37	3,53	2,32
	2,1	248,1	193,4	8	15	182	268	2,1	0,28	2,37	3,53	2,32
	2,1	248,1	–	8	15	182	268	2,1	0,28	2,37	3,53	2,32
	2,1	248,1	–	8	15	182	268	2,1	0,28	2,37	3,53	2,32
	2,1	240	194,1	4,8	9,5	182	268	2,1	0,36	1,9	2,83	1,86
	2,1	240	194,1	4,8	9,5	182	268	2,1	0,36	1,9	2,83	1,86
	4	275,4	199,8	9,5	17,7	187	293	3	0,26	2,6	3,87	2,54
	4	275,4	199,8	9,5	17,7	187	293	3	0,26	2,6	3,87	2,54
	4	267,4	199,8	8	15	187	293	3	0,33	2,03	3,02	1,98
	4	267,4	199,8	8	15	187	293	3	0,33	2,03	3,02	1,98
	4	267,4	–	8	15	187	293	3	0,33	2,03	3,02	1,98
4	267,4	–	8	15	187	293	3	0,33	2,03	3,02	1,98	
4	303,9	213,1	9,5	17,7	187	343	3	0,35	1,95	2,9	1,91	
4	303,9	213,1	9,5	17,7	187	343	3	0,35	1,95	2,9	1,91	





Spherical roller bearings

With cylindrical or tapered bore

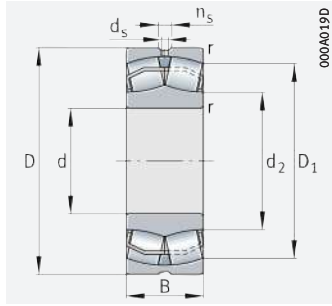

Cylindrical bore

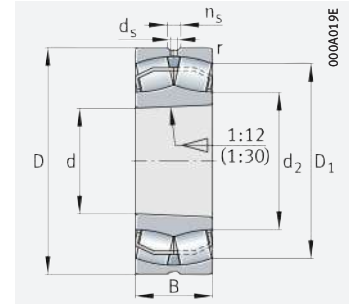

Tapered bore

d = 180 – 180 mm

Main dimensions			Basic load ratings		Fatigue limit load	Limiting speed	Speed rating	Mass	Designation
d	D	B	dyn. C _r	stat. C _{0r}	C _{ur}	n _G	n _{∅r}	m	▶ 681 1.12 ▶ 683 1.13 X-life ▶ 671
			kN	kN	N	min ⁻¹	min ⁻¹	≈ kg	
180	250	52	445	840	57 000	3 200	1 850	7,8	23936-S-K-MB
	250	52	445	840	57 000	3 200	1 850	8	23936-S-MB
	280	74	1 040	1 450	169 000	2 600	1 760	15,6	23036-E1-XL-K-TVPB
	280	74	1 040	1 450	169 000	2 600	1 760	15,9	23036-E1-XL-TVPB
	280	74	1 040	1 450	169 000	2 600	1 760	16	23036-E1A-XL-K-M
	280	74	1 040	1 450	169 000	2 600	1 760	16,8	23036-E1A-XL-M
	280	100	1 130	1 770	180 000	2 200	1 420	22,7	24036-BE-XL
	280	100	1 130	1 770	180 000	2 200	1 420	21,8	24036-BE-XL-K30
	300	96	1 420	1 950	194 000	2 230	1 350	25,9	23136-E1-XL-K-TVPB
	300	96	1 420	1 950	194 000	2 230	1 350	27,3	23136-E1-XL-TVPB
	300	96	1 420	1 950	194 000	2 230	1 350	25,5	23136-E1A-XL-K-M
	300	96	1 420	1 950	194 000	2 230	1 350	26,1	23136-E1A-XL-M
	300	118	1 460	2 170	203 000	2 000	980	33,2	24136-BE-XL
	300	118	1 460	2 170	203 000	2 000	980	32,5	24136-BE-XL-K30
	320	86	1 360	1 680	148 000	2 470	1 670	29,2	22236-E1-XL
	320	86	1 360	1 680	148 000	2 470	1 670	28,5	22236-E1-XL-K
	320	112	1 720	2 340	173 000	2 010	1 090	36	23236-E1-XL-K-TVPB
	320	112	1 720	2 340	173 000	2 010	1 090	37,2	23236-E1-XL-TVPB
	320	112	1 720	2 340	173 000	2 010	1 090	37	23236-E1A-XL-K-M
	320	112	1 720	2 340	173 000	2 010	1 090	38,5	23236-E1A-XL-M
380	126	2 060	2 460	190 000	2 030	1 230	68,1	22336-BE-XL	
380	126	2 060	2 460	190 000	2 030	1 230	66,6	22336-BE-XL-K	

medias ▶ <https://www.schaeffler.de/std/1ED4>

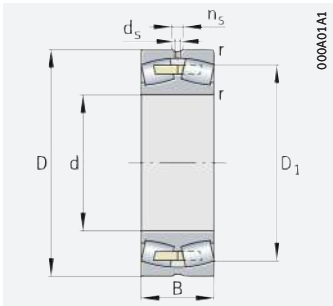

Solid cage, brass or steel;
cylindrical bore

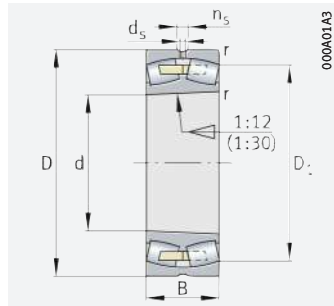

Solid cage, brass or steel;
tapered bore

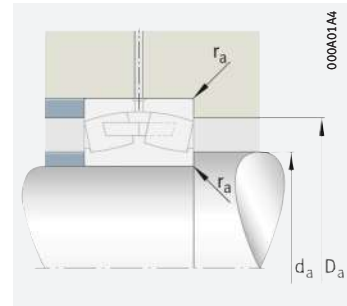

Mounting dimensions

Dimensions						Mounting dimensions			Calculation factors			
d	r	D ₁	d ₂	d _s	n _s	d _a	D _a	r _a	e	Y ₁	Y ₂	Y ₀
	min.	≈	≈			min.	max.	max.				
180	2	230,9	–	4,8	9,5	188,8	241,2	2	0,2	3,42	5,09	3,34
	2	230,9	–	4,8	9,5	188,8	241,2	2	0,2	3,42	5,09	3,34
	2,1	254,3	201,8	8	15	190,2	269,8	2,1	0,23	2,9	4,31	2,83
	2,1	254,3	201,8	8	15	190,2	269,8	2,1	0,23	2,9	4,31	2,83
	2,1	254,3	–	8	15	190,2	269,8	2,1	0,23	2,9	4,31	2,83
	2,1	254,3	–	8	15	190,2	269,8	2,1	0,23	2,9	4,31	2,83
	2,1	244,6	201,7	4,8	9,5	190,2	269,8	2,1	0,32	2,1	3,13	2,06
	2,1	244,6	201,7	4,8	9,5	190,2	269,8	2,1	0,32	2,1	3,13	2,06
	3	264,8	204,1	8	15	194	286	2,5	0,29	2,32	3,45	2,26
	3	264,8	204,1	8	15	194	286	2,5	0,29	2,32	3,45	2,26
	3	264,8	–	8	15	194	286	2,5	0,29	2,32	3,45	2,26
	3	264,8	–	8	15	194	286	2,5	0,29	2,32	3,45	2,26
	3	255,7	204,8	6,3	12,2	194	286	2,5	0,36	1,86	2,77	1,82
	3	255,7	204,8	6,3	12,2	194	286	2,5	0,36	1,86	2,77	1,82
	4	285,9	211,3	9,5	17,7	197	303	3	0,25	2,71	4,04	2,65
	4	285,9	211,3	9,5	17,7	197	303	3	0,25	2,71	4,04	2,65
	4	277,3	210,6	8	15	197	303	3	0,33	2,07	3,09	2,03
	4	277,3	210,6	8	15	197	303	3	0,33	2,07	3,09	2,03
	4	277,3	–	8	15	197	303	3	0,33	2,07	3,09	2,03
	4	277,3	–	8	15	197	303	3	0,33	2,07	3,09	2,03
4	320,8	224,9	12,5	23,5	197	363	3	0,34	1,96	2,92	1,92	
4	320,8	224,9	12,5	23,5	197	363	3	0,34	1,96	2,92	1,92	





Spherical roller bearings

With cylindrical or tapered bore

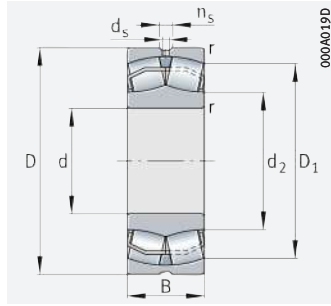

Cylindrical bore

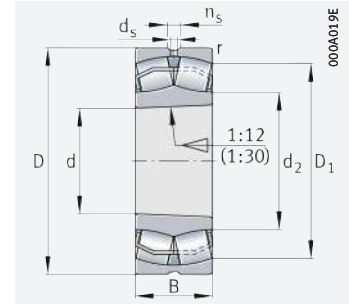

Tapered bore

d = 190 – 190 mm

Main dimensions			Basic load ratings		Fatigue limit load	Limiting speed	Speed rating	Mass	Designation
d	D	B	dyn. C _r	stat. C _{0r}	C _{ur}	n _G	n _{∅r}	m	▶681 1.12 ▶683 1.13 X-life ▶671
			kN	kN	N	min ⁻¹	min ⁻¹	≈ kg	
190	260	52	470	890	62 000	3 150	1 750	8,1	23938-S-K-MB
	260	52	470	890	62 000	3 150	1 750	8,4	23938-S-MB
	290	75	1 080	1 550	179 000	2 490	1 660	16,3	23038-E1-XL-K-TVPB
	290	75	1 080	1 550	179 000	2 490	1 660	17,2	23038-E1-XL-TVPB
	290	75	1 080	1 550	179 000	2 490	1 660	17,7	23038-E1A-XL-K-M
	290	75	1 080	1 550	179 000	2 490	1 660	18,3	23038-E1A-XL-M
	290	100	1 160	1 860	192 000	2 140	1 330	23,7	24038-BE-XL
	290	100	1 160	1 860	192 000	2 140	1 330	22,8	24038-BE-XL-K30
	320	104	1 610	2 220	216 000	2 070	1 260	30,3	23138-E1-XL-K-TVPB
	320	104	1 610	2 220	216 000	2 070	1 260	32	23138-E1-XL-TVPB
	320	104	1 610	2 220	216 000	2 070	1 260	32,4	23138-E1A-XL-K-M
	320	104	1 610	2 220	216 000	2 070	1 260	33,9	23138-E1A-XL-M
	320	128	1 680	2 550	226 000	1 850	880	41,5	24138-BE-XL
	320	128	1 680	2 550	226 000	1 850	880	40,7	24138-BE-XL-K30
	340	92	1 360	1 760	159 000	2 480	1 620	36,8	22238-BE-XL
	340	92	1 360	1 760	159 000	2 480	1 620	36	22238-BE-XL-K
	340	120	1 740	2 400	200 000	1 990	1 070	44,1	23238-BE-XL
	340	120	1 740	2 400	200 000	1 990	1 070	42,6	23238-BE-XL-K
	400	132	2 220	2 650	207 000	1 940	1 160	78,9	22338-BE-XL
400	132	2 220	2 650	207 000	1 940	1 160	77,2	22338-BE-XL-K	

medias ▶ <https://www.schaeffler.de/std/1ED5>

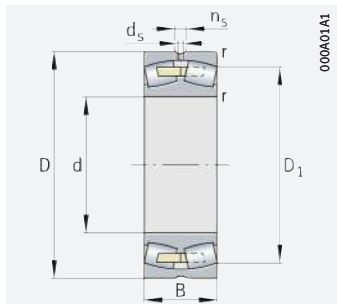

Solid cage, brass or steel;
cylindrical bore

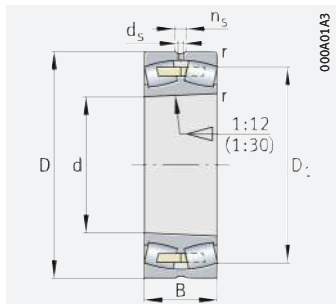

Solid cage, brass or steel;
tapered bore

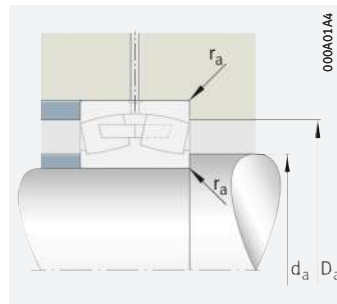

Mounting dimensions

Dimensions						Mounting dimensions			Calculation factors			
d	r	D ₁	d ₂	d _s	n _s	d _a	D _a	r _a	e	Y ₁	Y ₂	Y ₀
	min.	≈	≈			min.	max.	max.				
190	2	240,2	–	4,8	9,5	198,8	251,2	2	0,18	3,66	5,46	3,58
	2	240,2	–	4,8	9,5	198,8	251,2	2	0,18	3,66	5,46	3,58
	2,1	264,5	211,9	8	15	200,2	279,8	2,1	0,23	2,98	4,44	2,92
	2,1	264,5	211,9	8	15	200,2	279,8	2,1	0,23	2,98	4,44	2,92
	2,1	264,5	–	8	15	200,2	279,8	2,1	0,23	2,98	4,44	2,92
	2,1	264,5	–	8	15	200,2	279,8	2,1	0,23	2,98	4,44	2,92
	2,1	255	211,9	4,8	9,5	200,2	279,8	2,1	0,31	2,2	3,27	2,15
	2,1	255	211,9	4,8	9,5	200,2	279,8	2,1	0,31	2,2	3,27	2,15
	3	281,6	217	8	15	204	306	2,5	0,3	2,28	3,39	2,23
	3	281,6	217	8	15	204	306	2,5	0,3	2,28	3,39	2,23
	3	281,6	–	8	15	204	306	2,5	0,3	2,28	3,39	2,23
	3	281,6	–	8	15	204	306	2,5	0,3	2,28	3,39	2,23
	3	271,6	217,4	6,3	12,2	204	306	2,5	0,37	1,82	2,7	1,78
	3	271,6	217,4	6,3	12,2	204	306	2,5	0,37	1,82	2,7	1,78
	4	295,2	225,2	9,5	17,7	207	323	3	0,26	2,6	3,87	2,54
	4	295,2	225,2	9,5	17,7	207	323	3	0,26	2,6	3,87	2,54
4	289	222,4	9,5	17,7	207	323	3	0,34	1,98	2,94	1,93	
4	289	222,4	9,5	17,7	207	323	3	0,34	1,98	2,94	1,93	
5	338,1	236,8	12,5	23,5	210	380	4	0,34	1,96	2,92	1,92	
5	338,1	236,8	12,5	23,5	210	380	4	0,34	1,96	2,92	1,92	





Spherical roller bearings

With cylindrical or tapered bore

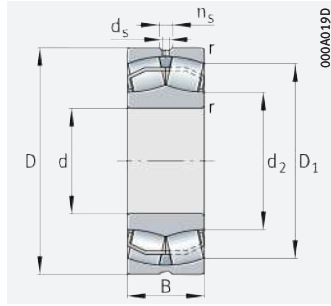

Cylindrical bore

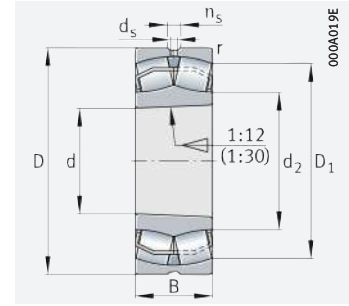

Tapered bore

d = 200 – 200 mm

Main dimensions			Basic load ratings		Fatigue limit load	Limiting speed	Speed rating	Mass	Designation
d	D	B	dyn. C _r	stat. C _{0r}	C _{ur}	n _G	n _{∅r}	m	▶ 681 1.12 ▶ 683 1.13 X-life ▶ 671
			kN	kN	N	min ⁻¹	min ⁻¹	≈ kg	
200	280	60	550	1 070	71 000	2 800	1 650	11,5	23940-S-K-MB
	280	60	550	1 070	71 000	2 800	1 650	11,8	23940-S-MB
	310	82	1 270	1 800	202 000	2 330	1 550	20,8	23040-E1-XL-K-TVPB
	310	82	1 270	1 800	202 000	2 330	1 550	21,5	23040-E1-XL-TVPB
	310	82	1 270	1 800	202 000	2 330	1 550	21,4	23040-E1A-XL-K-M
	310	82	1 270	1 800	202 000	2 330	1 550	22,8	23040-E1A-XL-M
	310	109	1 350	2 150	215 000	2 010	1 240	30,1	24040-BE-XL
	310	109	1 350	2 150	215 000	2 010	1 240	28,9	24040-BE-XL-K30
	340	112	1 610	2 270	188 000	2 040	1 230	41,5	23140-BE-XL
	340	112	1 610	2 270	188 000	2 040	1 230	40,9	23140-BE-XL-K
	340	140	1 880	2 800	250 000	1 780	840	49,5	24140-BE-XL
	340	140	1 880	2 800	250 000	1 780	840	48,5	24140-BE-XL-K30
	360	98	1 520	1 990	175 000	2 330	1 510	43,3	22240-BE-XL
	360	98	1 520	1 990	175 000	2 330	1 510	42,3	22240-BE-XL-K
	360	128	1 940	2 700	219 000	1 870	1 000	59	23240-BE-XL
	360	128	1 940	2 700	219 000	1 870	1 000	57,3	23240-BE-XL-K
	420	138	2 440	2 950	225 000	1 830	1 080	89,4	22340-BE-XL
	420	138	2 440	2 950	225 000	1 830	1 080	87,4	22340-BE-XL-K

medias ▶ <https://www.schaeffler.de/std/1ED6>

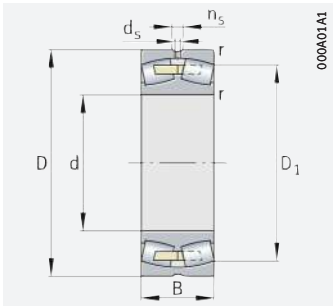

Solid cage, brass or steel;
cylindrical bore

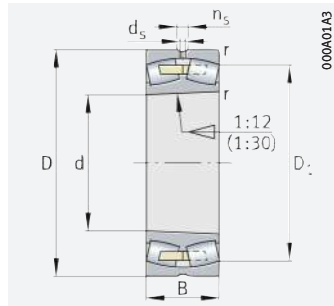

Solid cage, brass or steel;
tapered bore

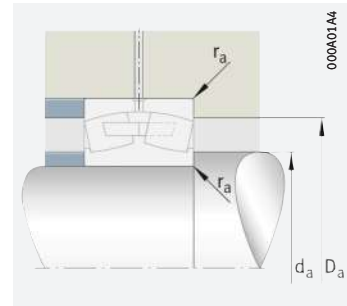

Mounting dimensions

Dimensions						Mounting dimensions			Calculation factors			
d	r	D ₁	d ₂	d _s	n _s	d _a	D _a	r _a	e	Y ₁	Y ₂	Y ₀
	min.	≈	≈			min.	max.	max.				
200	2,1	256,9	–	6,3	12,2	210,2	269,8	2,1	0,2	3,42	5,09	3,34
	2,1	256,9	–	6,3	12,2	210,2	269,8	2,1	0,2	3,42	5,09	3,34
	2,1	281,6	223,4	8	15	210,2	299,8	2,1	0,23	2,9	4,31	2,83
	2,1	281,6	223,4	8	15	210,2	299,8	2,1	0,23	2,9	4,31	2,83
	2,1	281,6	–	8	15	210,2	299,8	2,1	0,23	2,9	4,31	2,83
	2,1	281,6	–	8	15	210,2	299,8	2,1	0,23	2,9	4,31	2,83
	2,1	271,6	223,6	6,3	12,2	210,2	299,8	2,1	0,32	2,13	3,17	2,08
	2,1	271,6	223,6	6,3	12,2	210,2	299,8	2,1	0,32	2,13	3,17	2,08
	3	295,8	230,4	9,5	17,7	214	326	2,5	0,32	2,1	3,13	2,06
	3	295,8	230,4	9,5	17,7	214	326	2,5	0,32	2,1	3,13	2,06
	3	287,9	227,1	6,3	12,2	214	326	2,5	0,39	1,71	2,54	1,67
	3	287,9	227,1	6,3	12,2	214	326	2,5	0,39	1,71	2,54	1,67
	4	310,9	238,2	9,5	17,7	217	343	3	0,26	2,57	3,83	2,52
	4	310,9	238,2	9,5	17,7	217	343	3	0,26	2,57	3,83	2,52
	4	305,3	235	9,5	17,7	217	343	3	0,35	1,95	2,9	1,91
	4	305,3	235	9,5	17,7	217	343	3	0,35	1,95	2,9	1,91
5	355,1	248,8	12,5	23,5	220	400	4	0,34	1,98	2,94	1,93	
5	355,1	248,8	12,5	23,5	220	400	4	0,34	1,98	2,94	1,93	





Spherical roller bearings

With cylindrical or tapered bore

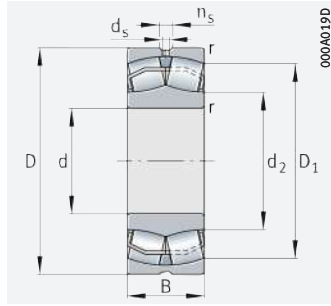

Cylindrical bore

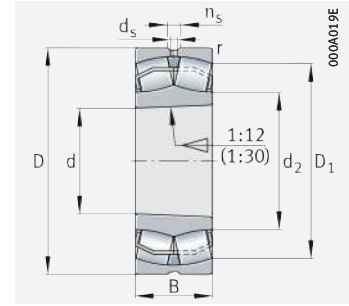

Tapered bore

d = 220 – 240 mm

Main dimensions			Basic load ratings		Fatigue limit load	Limiting speed	Speed rating	Mass	Designation
d	D	B	dyn. C _r	stat. C _{0r}	C _{ur}	n _G	n _{θr}	m	▶ 681 1.12 ▶ 683 1.13 X-life ▶ 671
			kN	kN	N	min ⁻¹	min ⁻¹	≈ kg	
220	300	60	610	1 240	72 000	2 600	1 460	12,3	23944-S-K-MB
	300	60	610	1 240	72 000	2 600	1 460	12,3	23944-S-MB
	340	90	1 260	1 900	177 000	2 230	1 450	29,4	23044-BE-XL
	340	90	1 260	1 900	177 000	2 230	1 450	28,5	23044-BE-XL-K
	340	118	1 620	2 600	250 000	1 830	1 090	39,3	24044-BE-XL
	340	118	1 620	2 600	250 000	1 830	1 090	37,7	24044-BE-XL-K30
	370	120	1 860	2 700	217 000	1 860	1 080	52,2	23144-BE-XL
	370	120	1 860	2 700	217 000	1 860	1 080	50,5	23144-BE-XL-K
	370	150	2 190	3 250	290 000	1 650	750	64	24144-BE-XL
	370	150	2 190	3 250	290 000	1 650	750	62,7	24144-BE-XL-K30
	400	108	1 840	2 360	210 000	2 140	1 350	59,6	22244-BE-XL
	400	108	1 840	2 360	210 000	2 140	1 350	58,3	22244-BE-XL-K
	400	144	2 380	3 300	265 000	1 700	880	77,7	23244-BE-XL
	400	144	2 380	3 300	265 000	1 700	880	75,3	23244-BE-XL-K
460	145	2 800	3 400	265 000	1 690	950	117	22344-BE-XL	
460	145	2 800	3 400	265 000	1 690	950	114	22344-BE-XL-K	
240	320	60	640	1 370	93 000	2 440	1 310	13,4	23948-K-MB
	320	60	640	1 370	93 000	2 440	1 310	13,9	23948-MB
	360	92	1 350	2 120	194 000	2 080	1 310	32,6	23048-BE-XL
	360	118	1 670	2 850	275 000	1 710	980	44,1	24048-BE-XL
	400	128	2 130	3 150	248 000	1 700	970	64	23148-BE-XL
	400	160	2 600	3 900	330 000	1 470	650	83,2	24148-BE-XL
	440	120	2 230	2 900	247 000	1 900	1 200	83,6	22248-BE-XL
	440	160	2 850	4 000	310 000	1 500	770	106	23248-BE-XL
	500	155	3 200	4 050	305 000	1 510	830	151	22348-BEA-XL-MB1

medias ▶ <https://www.schaeffler.de/std/1ED7>

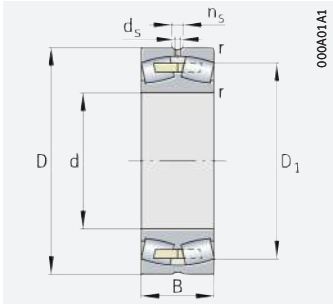

Solid cage, brass or steel;
cylindrical bore

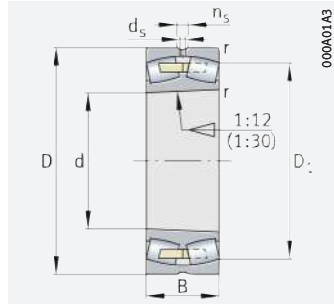

Solid cage, brass or steel;
tapered bore

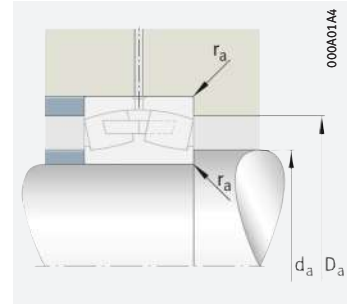

Mounting dimensions

Dimensions						Mounting dimensions			Calculation factors			
d	r	D ₁	d ₂	d _s	n _s	d _a	D _a	r _a	e	Y ₁	Y ₂	Y ₀
	min.	≈	≈			min.	max.	max.				
220	2,1	277,4	–	6,3	12,2	230,2	289,8	2,1	0,18	3,76	5,59	3,67
	2,1	277,4	–	6,3	12,2	230,2	289,8	2,1	0,18	3,76	5,59	3,67
	3	304,5	248,8	8	15	232,4	327,6	2,5	0,24	2,81	4,19	2,75
	3	304,5	248,8	8	15	232,4	327,6	2,5	0,24	2,81	4,19	2,75
	3	295,7	245	6,3	12,2	232,4	327,6	2,5	0,32	2,1	3,13	2,06
	3	295,7	245	6,3	12,2	232,4	327,6	2,5	0,32	2,1	3,13	2,06
	4	323	254,8	9,5	17,7	237	353	3	0,31	2,15	3,2	2,1
	4	323	254,8	9,5	17,7	237	353	3	0,31	2,15	3,2	2,1
	4	314,3	247,6	6,3	12,2	237	353	3	0,39	1,74	2,59	1,7
	4	314,3	247,6	6,3	12,2	237	353	3	0,39	1,74	2,59	1,7
	4	346,6	260,1	9,5	17,7	237	383	3	0,26	2,57	3,83	2,52
	4	346,6	260,1	9,5	17,7	237	383	3	0,26	2,57	3,83	2,52
	4	338	255,8	9,5	17,7	237	383	3	0,36	1,9	2,83	1,86
	4	338	255,8	9,5	17,7	237	383	3	0,36	1,9	2,83	1,86
5	391,1	273,4	12,5	23,5	240	440	4	0,33	2,06	3,06	2,01	
5	391,1	273,4	12,5	23,5	240	440	4	0,33	2,06	3,06	2,01	
240	2,1	297,8	–	6,3	12,2	250,2	309,8	2,1	0,17	4,05	6,04	3,96
	2,1	297,8	–	6,3	12,2	250,2	309,8	2,1	0,17	4,05	6,04	3,96
	3	324,6	269,5	8	15	252,4	347,6	2,5	0,23	2,98	4,44	2,92
	3	317,2	268,5	6,3	12,2	252,4	347,6	2,5	0,3	2,28	3,39	2,23
	4	349,9	275,9	9,5	17,7	257	383	3	0,31	2,18	3,24	2,13
	4	339	267,3	6,3	12,2	257	383	3	0,39	1,71	2,54	1,67
	4	380,4	285,6	12,5	23,5	257	423	3	0,26	2,55	3,8	2,5
	4	370,8	280,8	12,5	23,5	257	423	3	0,36	1,87	2,79	1,83
	5	426,4	–	12,5	23,5	260	480	4	0,32	2,12	3,15	2,07





Spherical roller bearings

With cylindrical or tapered bore

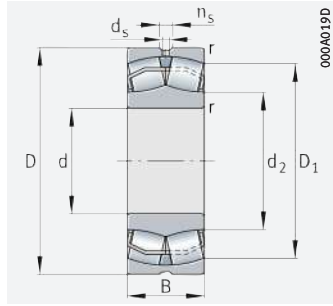

Cylindrical bore

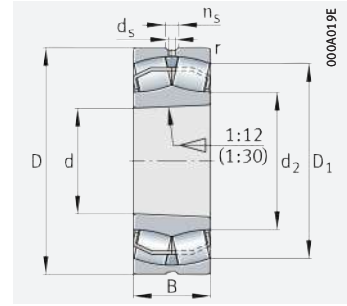

Tapered bore

d = 260 – 280 mm

Main dimensions			Basic load ratings		Fatigue limit load C_{ur}	Limiting speed n_G	Speed rating $n_{\theta r}$	Mass m	Designation
d	D	B	dyn. C_r	stat. C_{0r}					
			kN	kN	N	min^{-1}	min^{-1}	\approx kg	
260	360	75	940	1 940	108 000	2 100	1 190	22,4	23952-K-MB
	360	75	940	1 940	108 000	2 100	1 190	24,1	23952-MB
	400	104	1 670	2 600	233 000	1 850	1 170	47,4	23052-BE-XL
	400	104	1 670	2 600	233 000	1 850	1 170	45,9	23052-BE-XL-K
	400	140	2 210	3 650	335 000	1 510	880	63,8	24052-BE-XL
	400	140	2 210	3 650	335 000	1 510	880	61,2	24052-BE-XL-K30
	440	144	2 600	3 900	305 000	1 500	860	90	23152-BE-XL
	440	144	2 600	3 900	305 000	1 500	860	87,2	23152-BE-XL-K
	440	180	3 150	4 900	390 000	1 290	560	110	24152-BE-XL
	440	180	3 150	4 900	390 000	1 290	560	108	24152-BE-XL-K30
	480	130	2 600	3 450	290 000	1 720	1 070	104	22252-BEA-XL-K-MB1
	480	130	2 600	3 450	290 000	1 720	1 070	106	22252-BEA-XL-MB1
	480	174	3 350	4 750	360 000	1 360	690	134	23252-BEA-XL-K-MB1
	480	174	3 350	4 750	360 000	1 360	690	139	23252-BEA-XL-MB1
	540	165	3 650	4 650	350 000	1 390	740	179	22352-BEA-XL-K-MB1
	540	165	3 650	4 650	350 000	1 390	740	182	22352-BEA-XL-MB1
280	380	75	970	2 040	129 000	2 000	1 100	24,7	23956-K-MB
	380	75	970	2 040	129 000	2 000	1 100	25,5	23956-MB
	420	106	1 780	2 850	255 000	1 740	1 090	50,9	23056-BE-XL
	420	106	1 780	2 850	255 000	1 740	1 090	49,3	23056-BE-XL-K
	420	140	2 290	3 950	360 000	1 420	800	70,6	24056-BE-XL
	420	140	2 290	3 950	360 000	1 420	800	67,8	24056-BE-XL-K30
	460	146	2 750	4 200	315 000	1 420	790	96,3	23156-BE-XL
	460	146	2 750	4 200	315 000	1 420	790	93,1	23156-BE-XL-K
	460	180	3 300	5 200	425 000	1 230	520	116	24156-BE-XL
	460	180	3 300	5 200	425 000	1 230	520	114	24156-BE-XL-K30
	500	130	2 750	3 700	310 000	1 650	990	109	22256-BEA-XL-K-MB1
	500	130	2 750	3 700	310 000	1 650	990	112	22256-BEA-XL-MB1
	500	176	3 550	5 200	385 000	1 280	630	143,7	23256-BEA-XL-K-MB1
	500	176	3 550	5 200	385 000	1 280	630	148	23256-BEA-XL-MB1
	580	175	4 150	5 300	395 000	1 280	670	223	22356-BEA-XL-K-MB1
	580	175	4 150	5 300	395 000	1 280	670	228	22356-BEA-XL-MB1

medias ► <https://www.schaeffler.de/std/1ED8>

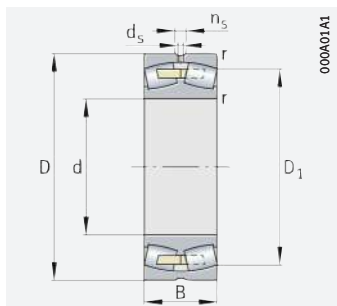

Solid cage, brass or steel;
cylindrical bore

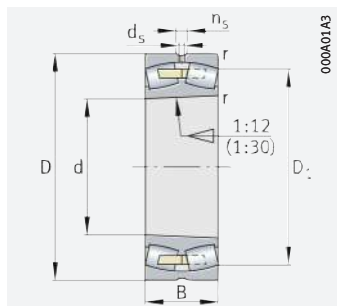

Solid cage, brass or steel;
tapered bore

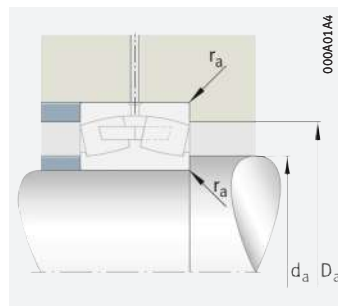

Mounting dimensions

Dimensions						Mounting dimensions			Calculation factors			
d	r	D ₁	d ₂	d _s	n _s	d _a	D _a	r _a	e	Y ₁	Y ₂	Y ₀
	min.	≈	≈			min.	max.	max.				
260	2,1	330,5	–	8	15	270,2	349,8	2,1	0,19	3,54	5,27	3,46
	2,1	330,5	–	8	15	270,2	349,8	2,1	0,19	3,54	5,27	3,46
	4	358,7	295,5	9,5	17,7	274,6	385,4	3	0,23	2,9	4,31	2,83
	4	358,7	295,5	9,5	17,7	274,6	385,4	3	0,23	2,9	4,31	2,83
	4	349	288,3	6,3	12,2	274,6	385,4	3	0,32	2,09	3,11	2,04
	4	349	288,3	6,3	12,2	274,6	385,4	3	0,32	2,09	3,11	2,04
	4	382,7	301,7	9,5	17,7	277	423	3	0,32	2,12	3,15	2,07
	4	382,7	301,7	9,5	17,7	277	423	3	0,32	2,12	3,15	2,07
	4	370,6	292,2	8	15	277	423	3	0,4	1,67	2,49	1,63
	4	370,6	292,2	8	15	277	423	3	0,4	1,67	2,49	1,63
	5	415,1	–	12,5	23,5	280	460	4	0,26	2,57	3,83	2,52
	5	415,1	–	12,5	23,5	280	460	4	0,26	2,57	3,83	2,52
	5	404,3	–	12,5	23,5	280	460	4	0,36	1,87	2,79	1,83
	5	404,3	–	12,5	23,5	280	460	4	0,36	1,87	2,79	1,83
6	460,6	–	12,5	23,5	286	514	5	0,31	2,15	3,2	2,1	
6	460,6	–	12,5	23,5	286	514	5	0,31	2,15	3,2	2,1	
280	2,1	350	–	8	15	290,2	369,8	2,1	0,18	3,76	5,59	3,67
	2,1	350	–	8	15	290,2	369,8	2,1	0,18	3,76	5,59	3,67
	4	379,2	314,3	9,5	17,7	294,6	405,4	3	0,22	3,01	4,48	2,94
	4	379,2	314,3	9,5	17,7	294,6	405,4	3	0,22	3,01	4,48	2,94
	4	370,5	310,3	6,3	12,2	294,6	405,4	3	0,3	2,23	3,32	2,18
	4	370,5	310,3	6,3	12,2	294,6	405,4	3	0,3	2,23	3,32	2,18
	5	403,4	321,4	9,5	17,7	300	440	4	0,31	2,21	3,29	2,16
	5	403,4	321,4	9,5	17,7	300	440	4	0,31	2,21	3,29	2,16
	5	392,4	312,8	8	15	300	440	4	0,38	1,76	2,62	1,72
	5	392,4	312,8	8	15	300	440	4	0,38	1,76	2,62	1,72
	5	436	–	12,5	23,5	300	480	4	0,25	2,71	4,04	2,65
	5	436	–	12,5	23,5	300	480	4	0,25	2,71	4,04	2,65
	5	425,4	–	12,5	23,5	300	480	4	0,34	1,96	2,92	1,92
	5	425,4	–	12,5	23,5	300	480	4	0,34	1,96	2,92	1,92
	6	495,5	–	12,5	23,5	306	554	5	0,31	2,18	3,24	2,13
	6	495,5	–	12,5	23,5	306	554	5	0,31	2,18	3,24	2,13





Spherical roller bearings

With cylindrical or tapered bore

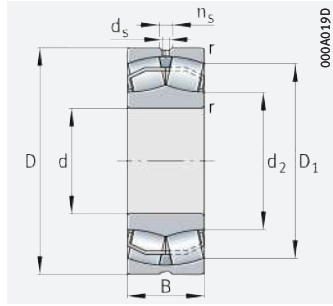

Cylindrical bore

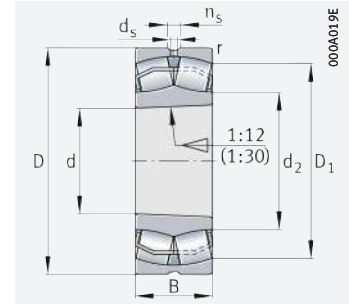

Tapered bore

d = 300 – 320 mm

Main dimensions			Basic load ratings		Fatigue limit load	Limiting speed	Speed rating	Mass	Designation
d	D	B	dyn. C_r	stat. C_{0r}	C_{ur}	n_G	$n_{\theta r}$	m	▶ 681 1.12 ▶ 683 1.13 X-life ▶ 671
			kN	kN	N	min ⁻¹	min ⁻¹	≈ kg	
300	420	90	1 270	2 650	165 000	1 780	1 000	39,1	23960-B-K-MB
	420	90	1 270	2 650	165 000	1 780	1 000	40,6	23960-B-MB
	460	118	2 160	3 450	295 000	1 570	980	70,5	23060-BE-XL
	460	118	2 160	3 450	295 000	1 570	980	68,4	23060-BE-XL-K
	460	160	2 850	4 900	425 000	1 250	720	101	24060-BE-XL
	460	160	2 850	4 900	425 000	1 250	720	97	24060-BE-XL-K30
	500	160	3 250	4 950	365 000	1 300	720	126	23160-BEA-XL-K-MB1
	500	160	3 250	4 950	365 000	1 300	720	130	23160-BEA-XL-MB1
	500	200	3 950	6 400	485 000	1 100	450	164	24160-BE-XL
	500	200	3 950	6 400	485 000	1 100	450	161	24160-BE-XL-K30
	540	140	3 100	4 250	355 000	1 500	900	139	22260-BEA-XL-K-MB1
	540	140	3 100	4 250	355 000	1 500	900	142	22260-BEA-XL-MB1
	540	192	4 100	6 100	440 000	1 160	560	187	23260-BEA-XL-K-MB1
	540	192	4 100	6 100	440 000	1 160	560	193	23260-BEA-XL-MB1
320	440	90	1 310	2 750	201 000	1 700	930	41	23964-K-MB
	440	90	1 310	2 750	201 000	1 700	930	41,8	23964-MB
	480	121	2 300	3 750	320 000	1 480	920	75,6	23064-BEA-XL-K-MB1
	480	121	2 300	3 750	320 000	1 480	920	78	23064-BEA-XL-MB1
	480	160	2 950	5 200	455 000	1 200	670	99	24064-BEA-XL-K30-MB1
	480	160	2 950	5 200	455 000	1 200	670	102	24064-BEA-XL-MB1
	540	176	3 800	5 900	415 000	1 170	650	161	23164-BEA-XL-K-MB1
	540	176	3 800	5 900	415 000	1 170	650	165	23164-BEA-XL-MB1
	540	218	4 600	7 300	560 000	1 010	415	209	24164-BE-XL
	540	218	4 600	7 300	560 000	1 010	415	205	24164-BE-XL-K30
	580	150	3 550	4 700	395 000	1 410	830	171	22264-BEA-XL-K-MB1
	580	150	3 550	4 700	395 000	1 410	830	174	22264-BEA-XL-MB1
	580	208	4 650	7 000	495 000	1 060	510	229,6	23264-BEA-XL-K-MB1
	580	208	4 650	7 000	495 000	1 060	510	237	23264-BEA-XL-MB1

medias ▶ <https://www.schaeffler.de/std/1ED9>

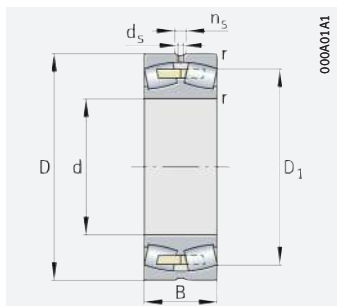

Solid cage, brass or steel;
cylindrical bore

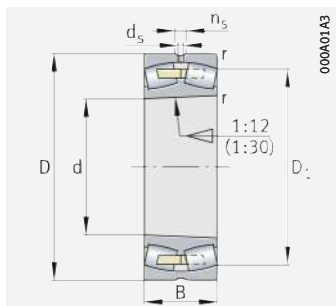

Solid cage, brass or steel;
tapered bore

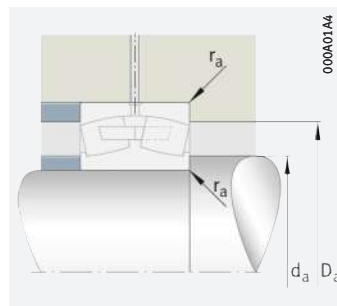

Mounting dimensions

Dimensions						Mounting dimensions			Calculation factors			
d	r	D ₁	d ₂	d _s	n _s	d _a	D _a	r _a	e	Y ₁	Y ₂	Y ₀
	min.	≈	≈			min.	max.	max.				
300	3	384,6	–	9,5	17,7	312,4	407,6	2,5	0,2	3,42	5,09	3,34
	3	384,6	–	9,5	17,7	312,4	407,6	2,5	0,2	3,42	5,09	3,34
	4	413	340	9,5	17,7	314,6	445,4	3	0,23	2,92	4,35	2,86
	4	413	340	9,5	17,7	314,6	445,4	3	0,23	2,92	4,35	2,86
	4	403	334,8	8	15	314,6	445,4	3	0,32	2,12	3,15	2,07
	4	403	334,8	8	15	314,6	445,4	3	0,32	2,12	3,15	2,07
	5	436,8	–	9,5	17,7	320	480	4	0,31	2,18	3,24	2,13
	5	436,8	–	9,5	17,7	320	480	4	0,31	2,18	3,24	2,13
	5	422,8	338,2	8	15	320	480	4	0,39	1,72	2,56	1,68
	5	422,8	338,2	8	15	320	480	4	0,39	1,72	2,56	1,68
	5	470,5	–	12,5	23,5	320	520	4	0,25	2,71	4,04	2,65
	5	470,5	–	12,5	23,5	320	520	4	0,25	2,71	4,04	2,65
	5	458	–	12,5	23,5	320	520	4	0,35	1,92	2,86	1,88
	5	458	–	12,5	23,5	320	520	4	0,35	1,92	2,86	1,88
320	3	406,2	–	9,5	17,7	332,4	427,6	2,5	0,19	3,62	5,39	3,54
	3	406,2	–	9,5	17,7	332,4	427,6	2,5	0,19	3,62	5,39	3,54
	4	433	–	9,5	17,7	334,6	465,4	3	0,22	3,01	4,48	2,94
	4	433	–	9,5	17,7	334,6	465,4	3	0,22	3,01	4,48	2,94
	4	422,3	–	8	15	334,6	465,4	3	0,3	2,23	3,32	2,18
	4	422,3	–	8	15	334,6	465,4	3	0,3	2,23	3,32	2,18
	5	469,3	–	12,5	23,5	340	520	4	0,32	2,13	3,17	2,08
	5	469,3	–	12,5	23,5	340	520	4	0,32	2,13	3,17	2,08
	5	455,5	359	9,5	17,7	340	520	4	0,4	1,69	2,52	1,65
	5	455,5	359	9,5	17,7	340	520	4	0,4	1,69	2,52	1,65
	5	505,1	–	12,5	23,5	340	560	4	0,25	2,71	4,04	2,65
	5	505,1	–	12,5	23,5	340	560	4	0,25	2,71	4,04	2,65
	5	490,4	–	12,5	23,5	340	560	4	0,35	1,91	2,85	1,87
	5	490,4	–	12,5	23,5	340	560	4	0,35	1,91	2,85	1,87





Spherical roller bearings

With cylindrical or tapered bore

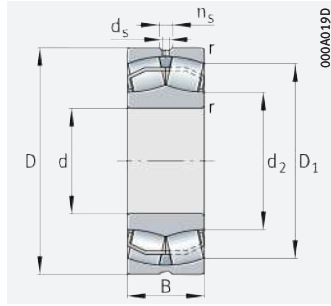

Cylindrical bore

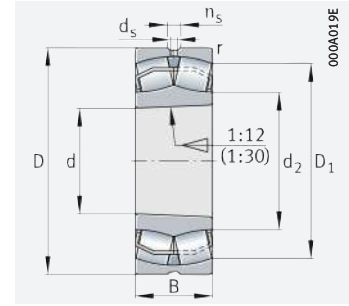

Tapered bore

d = 340 – 380 mm

Main dimensions			Basic load ratings		Fatigue limit load	Limiting speed	Speed rating	Mass	Designation
d	D	B	dyn. C _r	stat. C _{0r}	C _{ur}	n _G	n _{θr}	m	▶ 681 1.12 ▶ 683 1.13 X-life ▶ 671
			kN	kN	N	min ⁻¹	min ⁻¹	≈ kg	
340	460	90	1 370	3 000	198 000	1 610	860	42,9	23968-K-MB
	460	90	1 370	3 000	198 000	1 610	860	43,7	23968-MB
	520	133	2 700	4 400	365 000	1 360	840	101	23068-BEA-XL-K-MB1
	520	133	2 700	4 400	365 000	1 360	840	104	23068-BEA-XL-MB1
	520	180	3 550	6 200	520 000	1 080	610	136	24068-BEA-XL-K30-MB1
	520	180	3 550	6 200	520 000	1 080	610	139	24068-BEA-XL-MB1
	580	190	4 350	6 600	465 000	1 090	600	204	23168-BEA-XL-K-MB1
	580	190	4 350	6 600	465 000	1 090	600	210	23168-BEA-XL-MB1
	580	243	5 400	8 800	620 000	900	370	267	24168-BE-XL
	580	243	5 400	8 800	620 000	900	370	263	24168-BE-XL-K30
	620	165	4 100	5 600	445 000	1 280	770	217	22268-BEA-XL-K-MB1
	620	165	4 100	5 600	445 000	1 280	770	221	22268-BEA-XL-MB1
360	620	224	5 300	7 900	570 000	1 000	475	292	23268-BEA-XL-K-MB1
	620	224	5 300	7 900	570 000	1 000	475	301	23268-BEA-XL-MB1
	480	90	1 440	3 200	210 000	1 540	800	45	23972-K-MB
	480	90	1 440	3 200	210 000	1 540	800	46,5	23972-MB
	540	134	2 800	4 650	390 000	1 300	790	108	23072-BEA-XL-MB1
	540	180	3 650	6 600	550 000	1 040	570	144	24072-BEA-XL-MB1
	600	192	4 550	7 100	495 000	1 040	560	222	23172-BEA-XL-MB1
	600	243	5 600	9 100	660 000	890	350	277	24172-BE-XL
	600	243	5 600	9 100	660 000	890	350	272	24172-BE-XL-K30
	650	170	4 450	6 200	485 000	1 190	710	245	22272-BEA-XL-K-MB1
	650	170	4 450	6 200	485 000	1 190	710	251	22272-BEA-XL-MB1
	650	232	5 700	8 900	610 000	930	430	341	23272-BEA-XL-MB1
380	520	106	1 780	4 000	265 000	1 340	750	66,3	23976-K-MB
	520	106	1 780	4 000	265 000	1 340	750	69,1	23976-MB
	560	135	2 900	5 000	410 000	1 230	740	114	23076-BEA-XL-MB1
	560	180	3 750	7 000	590 000	990	530	153	24076-BEA-XL-MB1
	620	194	4 700	7 600	530 000	990	530	234	23176-BEA-XL-MB1
	620	243	5 800	9 700	710 000	850	325	290	24176-BE-XL
	620	243	5 800	9 700	710 000	850	325	285	24176-BE-XL-K30
	680	240	6 200	9 600	660 000	890	400	385	23276-BEA-XL-MB1

medias ▶ <https://www.schaeffler.de/std/1EDA>

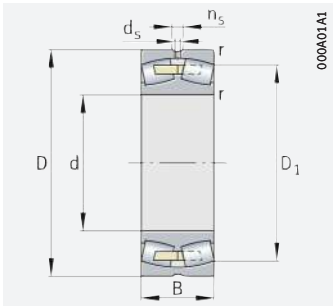

Solid cage, brass or steel;
cylindrical bore

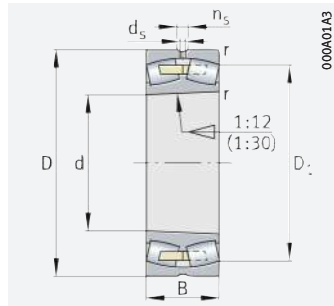

Solid cage, brass or steel;
tapered bore

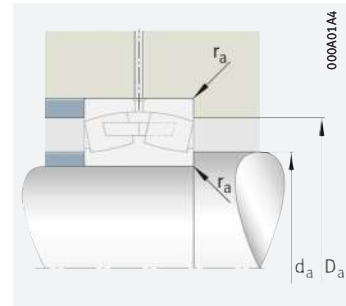

Mounting dimensions

Dimensions						Mounting dimensions			Calculation factors			
d	r	D ₁	d ₂	d _s	n _s	d _a	D _a	r _a	e	Y ₁	Y ₂	Y ₀
	min.	≈	≈			min.	max.	max.				
340	3	426,7	–	9,5	17,7	352,4	447,6	2,5	0,18	3,85	5,73	3,76
	3	426,7	–	9,5	17,7	352,4	447,6	2,5	0,18	3,85	5,73	3,76
	5	467,1	–	12,5	23,5	358	502	4	0,23	2,92	4,35	2,86
	5	467,1	–	12,5	23,5	358	502	4	0,23	2,92	4,35	2,86
	5	456,1	–	9,5	17,7	358	502	4	0,32	2,12	3,15	2,07
	5	456,1	–	9,5	17,7	358	502	4	0,32	2,12	3,15	2,07
	5	502,6	–	12,5	23,5	360	560	4	0,32	2,1	3,13	2,06
	5	502,6	–	12,5	23,5	360	560	4	0,32	2,1	3,13	2,06
	5	484,1	382,8	9,5	17,7	360	560	4	0,42	1,62	2,42	1,59
	5	484,1	382,8	9,5	17,7	360	560	4	0,42	1,62	2,42	1,59
	6	538,3	–	12,5	23,5	366	594	5	0,26	2,62	3,9	2,56
	6	538,3	–	12,5	23,5	366	594	5	0,26	2,62	3,9	2,56
6	523,5	–	12,5	23,5	366	594	5	0,36	1,85	2,76	1,81	
6	523,5	–	12,5	23,5	366	594	5	0,36	1,85	2,76	1,81	
360	3	447,1	–	9,5	17,7	372,4	467,6	2,5	0,17	4,05	6,04	3,96
	3	447,1	–	9,5	17,7	372,4	467,6	2,5	0,17	4,05	6,04	3,96
	5	487,6	–	12,5	23,5	378	522	4	0,22	3,04	4,53	2,97
	5	476,4	–	9,5	17,7	378	522	4	0,3	2,23	3,32	2,18
	5	523,3	–	12,5	23,5	380	580	4	0,31	2,18	3,24	2,13
	5	505,9	399,4	9,5	17,7	380	580	4	0,4	1,69	2,52	1,65
	5	505,9	399,4	9,5	17,7	380	580	4	0,4	1,69	2,52	1,65
	6	566	–	12,5	23,5	386	624	5	0,25	2,69	4	2,63
	6	566	–	12,5	23,5	386	624	5	0,25	2,69	4	2,63
	6	550,8	–	12,5	23,5	386	624	5	0,36	1,9	2,83	1,86
380	4	477,6	–	9,5	17,7	394,6	505,4	3	0,19	3,58	5,33	3,5
	4	477,6	–	9,5	17,7	394,6	505,4	3	0,19	3,58	5,33	3,5
	5	508,1	–	12,5	23,5	398	542	4	0,21	3,17	4,72	3,1
	5	497,9	–	9,5	17,7	398	542	4	0,29	2,33	3,47	2,28
	5	543,6	–	12,5	23,5	400	600	4	0,3	2,25	3,34	2,2
	5	528,4	421	9,5	17,7	400	600	4	0,38	1,76	2,62	1,72
	5	528,4	421	9,5	17,7	400	600	4	0,38	1,76	2,62	1,72
	6	578,1	–	12,5	23,5	406	654	5	0,35	1,92	2,86	1,88





Spherical roller bearings

With cylindrical or tapered bore

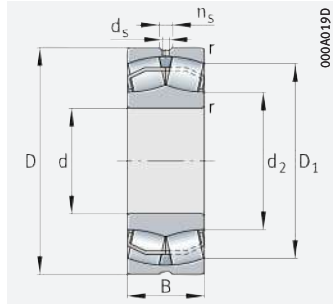

Cylindrical bore

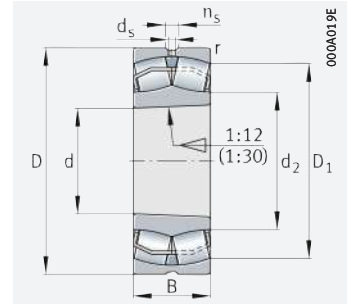

Tapered bore

d = 400 – 420 mm

Main dimensions			Basic load ratings		Fatigue limit load	Limiting speed	Speed rating	Mass	Designation
d	D	B	dyn. C _r	stat. C _{0r}	C _{ur}	n _G	n _{θr}	m	▶ 681 1.12 ▶ 683 1.13 X-life ▶ 671
			kN	kN	N	min ⁻¹	min ⁻¹	≈ kg	
400	540	106	1 830	4 150	270 000	1 290	710	68,2	23980-B-K-MB
	540	106	1 830	4 150	270 000	1 290	710	72,9	23980-B-MB
	600	148	3 400	5 700	465 000	1 150	690	149	23080-BEA-XL-MB1
	600	200	4 500	8 100	660 000	920	495	200	24080-BEA-XL-MB1
	650	200	5 000	8 100	570 000	950	495	255	23180-BEA-XL-MB1
	650	250	6 200	10 600	760 000	800	300	328	24180-BE-XL
	650	250	6 200	10 600	760 000	800	300	323	24180-BE-XL-K30
420	720	256	7 000	10 900	730 000	820	370	464	23280-BEA-XL-MB1
	560	106	1 910	4 450	300 000	1 230	660	72,1	23984-K-MB
	560	106	1 910	4 450	300 000	1 230	660	75,5	23984-MB
	620	150	3 650	6 300	510 000	1 090	650	153	23084-BEA-XL-K-MB1
	620	150	3 650	6 300	510 000	1 090	650	158	23084-BEA-XL-MB1
	620	200	4 600	8 500	710 000	890	465	205	24084-BEA-XL-K30-MB1
	620	200	4 600	8 500	710 000	890	465	208	24084-BEA-XL-MB1
	700	224	6 000	9 600	650 000	860	455	342	23184-BEA-XL-K-MB1
	700	224	6 000	9 600	650 000	860	455	353	23184-BEA-XL-MB1
	700	280	7 400	12 600	860 000	720	270	437	24184-BE-XL
	700	280	7 400	12 600	860 000	720	270	431	24184-BE-XL-K30
	760	272	7 800	12 300	800 000	770	340	537	23284-BEA-XL-K-MB1
	760	272	7 800	12 300	800 000	770	340	553	23284-BEA-XL-MB1

medias ▶ <https://www.schaeffler.de/std/1EDB>

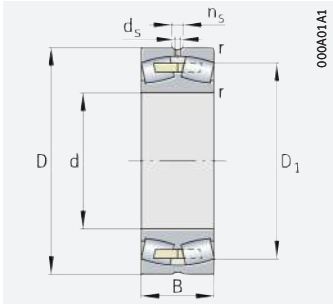

Solid cage, brass or steel;
cylindrical bore

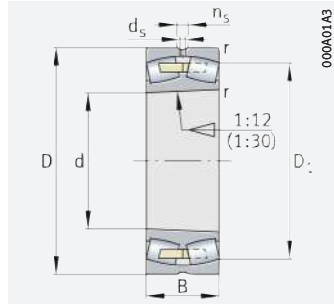

Solid cage, brass or steel;
tapered bore

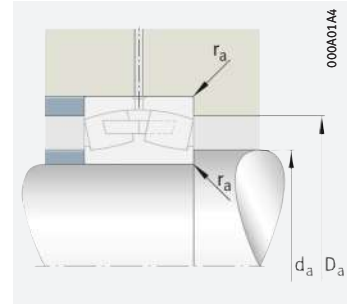

Mounting dimensions

Dimensions

Mounting dimensions

Calculation factors

d	r	D ₁	d ₂	d _s	n _s	d _a	D _a	r _a	e	Y ₁	Y ₂	Y ₀
400	4	499	–	9,5	17,7	414,6	525,4	3	0,18	3,71	5,52	3,63
	4	499	–	9,5	17,7	414,6	525,4	3	0,18	3,71	5,52	3,63
	5	541,9	–	12,5	23,5	418	582	4	0,22	3,07	4,57	3
	5	529,4	–	12,5	23,5	418	582	4	0,3	2,23	3,32	2,18
	6	571,4	–	12,5	23,5	426	624	5	0,29	2,3	3,42	2,25
	6	556,5	448,8	12,5	23,5	426	624	5	0,37	1,82	2,7	1,78
	6	556,5	448,8	12,5	23,5	426	624	5	0,37	1,82	2,7	1,78
	6	610,9	–	12,5	23,5	426	694	5	0,36	1,9	2,83	1,86
420	4	519,5	–	9,5	17,7	434,6	545,4	3	0,18	3,85	5,73	3,76
	4	519,5	–	9,5	17,7	434,6	545,4	3	0,18	3,85	5,73	3,76
	5	560,7	–	12,5	23,5	438	602	4	0,21	3,17	4,72	3,1
	5	560,7	–	12,5	23,5	438	602	4	0,21	3,17	4,72	3,1
	5	551	–	12,5	23,5	438	602	4	0,29	2,32	3,45	2,26
	5	551	–	12,5	23,5	438	602	4	0,29	2,32	3,45	2,26
	6	609,8	–	12,5	23,5	446	674	5	0,31	2,18	3,24	2,13
	6	609,8	–	12,5	23,5	446	674	5	0,31	2,18	3,24	2,13
	6	592,2	472,7	12,5	23,5	446	674	5	0,39	1,72	2,56	1,68
	6	592,2	472,7	12,5	23,5	446	674	5	0,39	1,72	2,56	1,68
	7,5	643,4	–	12,5	23,5	452	728	6	0,36	1,89	2,81	1,84
	7,5	643,4	–	12,5	23,5	452	728	6	0,36	1,89	2,81	1,84





Spherical roller bearings

With cylindrical or tapered bore

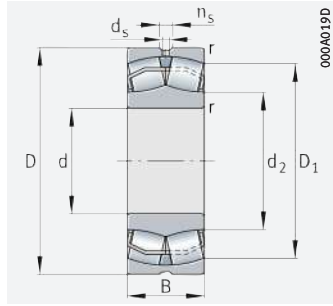

Cylindrical bore

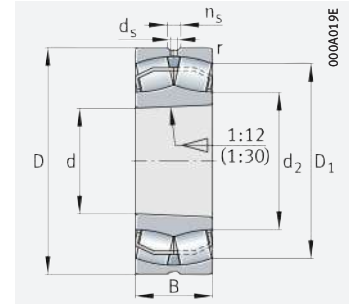

Tapered bore

d = 440 – 460 mm

Main dimensions			Basic load ratings		Fatigue limit load	Limiting speed	Speed rating	Mass	Designation
d	D	B	dyn. C _r	stat. C _{0r}	C _{ur}	n _G	n _{θr}	m	▶ 681 1.12 ▶ 683 1.13 X-life ▶ 671
			kN	kN	N	min ⁻¹	min ⁻¹	≈ kg	
440	600	118	2 230	5 200	295 000	1 130	620	98,3	23988-K-MB
	600	118	2 230	5 200	295 000	1 130	620	101	23988-MB
	650	157	3 950	6 900	550 000	1 030	610	176	23088-BEA-XL-K-MB1
	650	157	3 950	6 900	550 000	1 030	610	182	23088-BEA-XL-MB1
	650	212	5 100	9 500	760 000	830	435	238	24088-BEA-XL-K30-MB1
	650	212	5 100	9 500	760 000	830	435	243	24088-BEA-XL-MB1
	720	226	6 200	10 200	680 000	820	430	358	23188-BEA-XL-K-MB1
	720	226	6 200	10 200	680 000	820	430	370	23188-BEA-XL-MB1
	720	280	7 600	12 900	910 000	710	260	453	24188-BE-XL
	720	280	7 600	12 900	910 000	710	260	446	24188-BE-XL-K30
460	790	280	8 300	13 200	860 000	730	320	592	23288-BEA-XL-K-MB1
	790	280	8 300	13 200	860 000	730	320	610	23288-BEA-XL-MB1
	580	118	1 940	5 100	330 000	1 020	325	71	24892-B-MB
	620	118	2 270	5 400	370 000	1 080	590	103	23992-B-K-MB
	620	118	2 270	5 400	370 000	1 080	590	111	23992-B-MB
	680	163	4 300	7 500	590 000	980	580	201	23092-BEA-XL-K-MB1
	680	163	4 300	7 500	590 000	980	580	208	23092-BEA-XL-MB1
	680	218	5 500	10 200	820 000	800	410	270	24092-BEA-XL-K30-MB1
	680	218	5 500	10 200	820 000	800	410	274	24092-BEA-XL-MB1
	760	240	6 900	11 500	740 000	770	395	431	23192-BEA-XL-K-MB1
760	240	6 900	11 500	740 000	770	395	445	23192-BEA-XL-MB1	
760	300	8 500	14 500	1 000 000	660	241	531	24192-BEA-XL-K30-MB1	
760	300	8 500	14 500	1 000 000	660	241	540	24192-BEA-XL-MB1	
830	296	9 200	14 700	930 000	690	295	695	23292-BEA-XL-K-MB1	
830	296	9 200	14 700	930 000	690	295	716	23292-BEA-XL-MB1	

medias ▶ <https://www.schaeffler.de/std/1EDC>

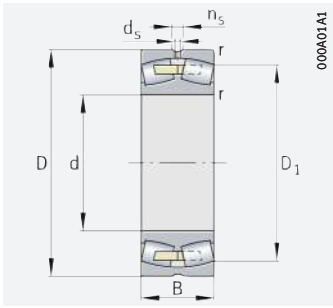

Solid cage, brass or steel;
cylindrical bore

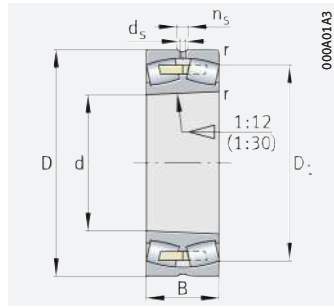

Solid cage, brass or steel;
tapered bore

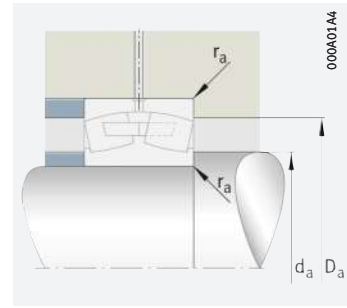

Mounting dimensions

Dimensions						Mounting dimensions			Calculation factors			
d	r	D ₁	d ₂	d _s	n _s	d _a	D _a	r _a	e	Y ₁	Y ₂	Y ₀
	min.	≈	≈			min.	max.	max.				
440	4	552,8	–	12,5	23,5	454,6	585,4	3	0,18	3,66	5,46	3,58
	4	552,8	–	12,5	23,5	454,6	585,4	3	0,18	3,66	5,46	3,58
	6	589,3	–	12,5	23,5	463	627	5	0,21	3,17	4,72	3,1
	6	589,3	–	12,5	23,5	463	627	5	0,21	3,17	4,72	3,1
	6	576,7	–	12,5	23,5	463	627	5	0,29	2,3	3,42	2,25
	6	576,7	–	12,5	23,5	463	627	5	0,29	2,3	3,42	2,25
	6	630,2	–	12,5	23,5	466	694	5	0,3	2,25	3,34	2,2
	6	630,2	–	12,5	23,5	466	694	5	0,3	2,25	3,34	2,2
	6	614,3	614,2	12,5	23,5	466	694	5	0,38	1,78	2,65	1,74
	6	614,3	614,2	12,5	23,5	466	694	5	0,38	1,78	2,65	1,74
	7,5	670,7	–	12,5	23,5	472	758	6	0,35	1,91	2,85	1,87
	7,5	670,7	–	12,5	23,5	472	758	6	0,35	1,91	2,85	1,87
460	3	542,6	–	6,3	12,2	472,4	567,6	2,5	0,18	3,76	5,59	3,67
	4	573,3	–	12,5	23,5	474,6	605,4	3	0,18	3,85	5,73	3,76
	4	573,3	–	12,5	23,5	474,6	605,4	3	0,18	3,85	5,73	3,76
	6	616,7	–	12,5	23,5	483	657	5	0,21	3,17	4,72	3,1
	6	616,7	–	12,5	23,5	483	657	5	0,21	3,17	4,72	3,1
	6	604,5	–	12,5	23,5	483	657	5	0,29	2,33	3,47	2,28
	6	604,5	–	12,5	23,5	483	657	5	0,29	2,33	3,47	2,28
	7,5	663,4	–	12,5	23,5	492	728	6	0,31	2,21	3,29	2,16
	7,5	663,4	–	12,5	23,5	492	728	6	0,31	2,21	3,29	2,16
	7,5	645,4	–	12,5	23,5	492	728	6	0,38	1,76	2,62	1,72
	7,5	645,4	–	12,5	23,5	492	728	6	0,38	1,76	2,62	1,72
	7,5	703,5	–	12,5	23,5	492	798	6	0,36	1,9	2,83	1,86
	7,5	703,5	–	12,5	23,5	492	798	6	0,36	1,9	2,83	1,86





Spherical roller bearings

With cylindrical or tapered bore

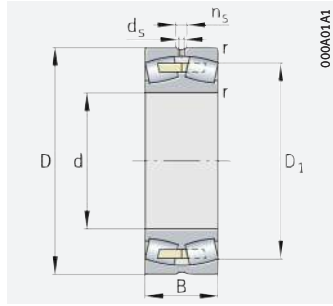

Solid cage, brass or steel;
cylindrical bore

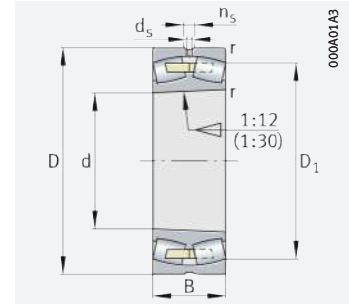

Solid cage, brass or steel;
tapered bore

d = 480 – 500 mm

Main dimensions			Basic load ratings		Fatigue limit load	Limiting speed	Speed rating	Mass	Designation
d	D	B	dyn. C _r	stat. C _{0r}	C _{ur}	n _G	n _{gr}	m	▶681 1.12 ▶683 1.13 X-life ▶671
			kN	kN	N	min ⁻¹	min ⁻¹	≈ kg	
480	600	118	2 000	5 400	360 000	980	305	78,4	24896-MB
	650	128	2 550	6 000	460 000	1 040	570	121	23996-B-K-MB
	650	128	2 550	6 000	460 000	1 040	570	126	23996-B-MB
	700	165	4 450	8 000	620 000	950	550	210	23096-BEA-XL-K-MB1
	700	165	4 450	8 000	620 000	950	550	217	23096-BEA-XL-MB1
	700	218	5 600	10 700	860 000	770	385	279	24096-BEA-XL-K30-MB1
	700	218	5 600	10 700	860 000	770	385	284	24096-BEA-XL-MB1
	790	248	7 400	12 400	790 000	740	375	479	23196-BEA-XL-K-MB1
	790	248	7 400	12 400	790 000	740	375	494	23196-BEA-XL-MB1
	790	308	9 000	15 500	1 070 000	640	227	594	24196-BEA-XL-K30-MB1
	790	308	9 000	15 500	1 070 000	640	227	603	24196-BEA-XL-MB1
	870	310	10 000	16 200	1 010 000	650	275	804	23296-BEA-XL-K-MB1
870	310	10 000	16 200	1 010 000	650	275	829	23296-BEA-XL-MB1	
500	620	118	2 070	5 700	265 000	930	290	84,3	248/500-B-MB
	670	128	2 600	6 300	400 000	990	540	124	239/500-K-MB
	670	128	2 600	6 300	400 000	990	540	132	239/500-MB
	720	167	4 700	8 700	750 000	890	510	223	230/500-BEA-XL-K-MB1
	720	167	4 700	8 700	750 000	890	510	230	230/500-BEA-XL-MB1
	720	218	5 700	11 100	900 000	750	370	289	240/500-BEA-XL-K30-MB1
	720	218	5 700	11 100	900 000	750	370	294	240/500-BEA-XL-MB1
	830	264	8 300	13 900	860 000	690	350	574	231/500-BEA-XL-K-MB1
	830	264	8 300	13 900	860 000	690	350	593	231/500-BEA-XL-MB1
	830	325	10 000	17 300	1 160 000	600	209	692	241/500-BEA-XL-K30-MB1
	830	325	10 000	17 300	1 160 000	600	209	703	241/500-BEA-XL-MB1
	920	336	11 300	18 000	1 110 000	610	260	983	232/500-BEA-XL-K-MB1
920	336	11 300	18 000	1 110 000	610	260	1 013	232/500-BEA-XL-MB1	

medias ▶ <https://www.schaeffler.de/std/1EDD>

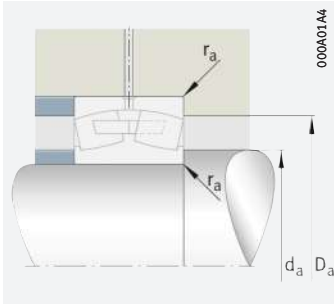

Mounting dimensions

Dimensions					Mounting dimensions			Calculation factors			
d	r	D ₁	d _s	n _s	d _a	D _a	r _a	e	Y ₁	Y ₂	Y ₀
	min.	≈			min.	max.	max.				
480	3	562,8	6,3	12,2	492	588	2,5	0,17	3,9	5,81	3,81
	5	598,8	12,5	23,5	498	632	4	0,18	3,76	5,59	3,67
	5	598,8	12,5	23,5	498	632	4	0,18	3,76	5,59	3,67
	6	636,9	12,5	23,5	503	677	5	0,21	3,27	4,87	3,2
	6	636,9	12,5	23,5	503	677	5	0,21	3,27	4,87	3,2
	6	626,1	12,5	23,5	503	677	5	0,28	2,43	3,61	2,37
	6	626,1	12,5	23,5	503	677	5	0,28	2,43	3,61	2,37
	7,5	690,4	12,5	23,5	512	758	6	0,3	2,23	3,32	2,18
	7,5	690,4	12,5	23,5	512	758	6	0,3	2,23	3,32	2,18
	7,5	673,14	12,5	23,5	512	758	6	0,38	1,79	2,67	1,75
	7,5	673,1	12,5	23,5	512	758	6	0,38	1,79	2,67	1,75
	7,5	737,1	12,5	23,5	512	838	6	0,36	1,9	2,83	1,86
7,5	737,1	12,5	23,5	512	838	6	0,36	1,9	2,83	1,86	
500	3	583,5	6,3	12,2	512,4	607,6	2,5	0,17	4	5,96	3,91
	5	619,3	12,5	23,5	518	652	4	0,17	3,9	5,81	3,81
	5	619,3	12,5	23,5	518	652	4	0,17	3,9	5,81	3,81
	6	657,1	12,5	23,5	523	697	5	0,21	3,24	4,82	3,16
	6	657,1	12,5	23,5	523	697	5	0,21	3,24	4,82	3,16
	6	647,3	12,5	23,5	523	697	5	0,27	2,51	3,74	2,45
	6	647,3	12,5	23,5	523	697	5	0,27	2,51	3,74	2,45
	7,5	723,1	12,5	23,5	532	798	6	0,31	2,2	3,27	2,15
	7,5	723,1	12,5	23,5	532	798	6	0,31	2,2	3,27	2,15
	7,5	705,2	12,5	23,5	532	798	6	0,38	1,78	2,65	1,74
	7,5	705,2	12,5	23,5	532	798	6	0,38	1,78	2,65	1,74
	7,5	774,6	12,5	23,5	532	888	6	0,37	1,83	2,72	1,79
	7,5	774,6	12,5	23,5	532	888	6	0,37	1,83	2,72	1,79



Spherical roller bearings

With cylindrical or tapered bore

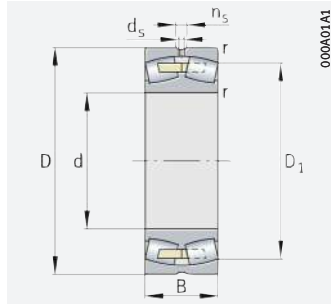

Solid cage, brass or steel; cylindrical bore

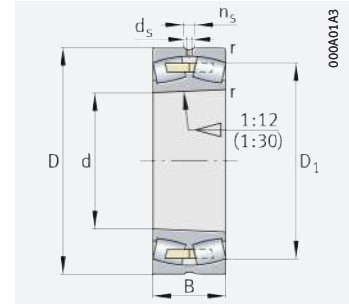

Solid cage, brass or steel; tapered bore

d = 530 – 600 mm

Main dimensions			Basic load ratings		Fatigue limit load	Limiting speed	Speed rating	Mass	Designation	
d	D	B	dyn. C _r	stat. C _{0r}	C _{ur}	n _G	n _{thr}	m		
			kN	kN	N	min ⁻¹	min ⁻¹	≈ kg		
530	650	118	2 240	6 400	370 000	880	260	89,7	248/530-B-MB	
	710	136	2 850	6 900	385 000	930	500	160	239/530-MB	
	780	185	5 600	10 100	860 000	820	475	312	230/530-BEA-XL-MB1	
	780	250	7 000	13 500	1 040 000	670	335	403	240/530-BEA-XL-K30-MB1	
	780	250	7 000	13 500	1 040 000	670	335	410	240/530-BEA-XL-MB1	
	870	272	8 900	15 000	940 000	660	325	655	231/530-BEA-XL-MB1	
	870	335	10 700	19 100	1 260 000	560	190	791	241/530-BEA-XL-MB1	
	980	355	10 900	20 900	1 190 000	570	230	1 202	232/530-K-MB	
	980	355	10 900	20 900	1 190 000	570	230	1 240	232/530-MB	
560	680	118	2 210	6 300	390 000	840	250	92,7	248/560-B-MB	
	750	140	3 100	7 600	520 000	880	465	181	239/560-B-MB	
	820	195	6 100	11 200	930 000	760	440	361	230/560-BEA-XL-MB1	
	820	258	7 500	14 600	1 120 000	630	315	459	240/560-BEA-XL-K30-MB1	
	820	258	7 500	14 600	1 120 000	630	315	466	240/560-BEA-XL-MB1	
	920	280	9 700	16 400	1 030 000	630	300	754	231/560-BEA-XL-MB1	
	920	355	12 000	21 000	1 410 000	530	177	929	241/560-BEA-XL-MB1	
	1 030	365	11 700	22 600	910 000	540	215	1 358	232/560-K-MB	
		1 030	365	11 700	22 600	910 000	540	215	1 397	232/560-MB
	600	730	98	1 960	5 300	350 000	980	435	84	238/600-K-MB
730		98	1 960	5 300	350 000	980	435	87	238/600-MB	
730		128	2 550	7 300	440 000	780	228	116	248/600-B-MB	
800		150	3 450	8 600	630 000	810	430	224	239/600-B-MB	
870		200	6 600	12 300	1 020 000	710	405	411	230/600-BEA-XL-MB1	
870		272	8 300	16 600	1 240 000	580	285	536	240/600-BEA-XL-K30-MB1	
870		272	8 300	16 600	1 240 000	580	285	545	240/600-BEA-XL-MB1	
980		300	9 000	19 200	810 000	560	270	929	231/600-MB	
980		375	11 600	26 000	1 780 000	480	149	1 180	241/600-B-MB	
1 090		388	13 000	25 500	1 720 000	495	196	1 599	232/600-B-K-MB	
		1 090	388	13 000	25 500	1 720 000	495	196	1 634	232/600-B-MB

medias ► <https://www.schaeffler.de/std/1EDE>

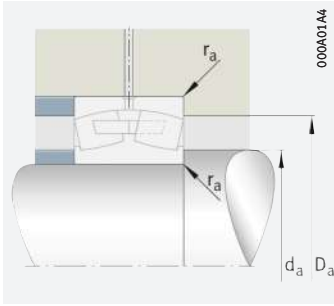

Mounting dimensions

Dimensions					Mounting dimensions			Calculation factors			
d	r	D ₁	d _s	n _s	d _a	D _a	r _a	e	Y ₁	Y ₂	Y ₀
	min.	≈			min.	max.	max.				
530	3	614,1	6,3	12,2	542,4	637,6	2,5	0,16	4,22	6,29	4,13
	5	656,5	12,5	23,5	548	692	4	0,18	3,85	5,73	3,76
	6	708,2	12,5	23,5	553	757	5	0,22	3,1	4,62	3,03
	6	694,2	12,5	23,5	553	757	5	0,29	2,33	3,47	2,28
	6	694,2	12,5	23,5	553	757	5	0,29	2,33	3,47	2,28
	7,5	760,5	12,5	23,5	562	838	6	0,3	2,25	3,34	2,2
	7,5	742,9	12,5	23,5	562	838	6	0,37	1,83	2,72	1,79
	9,5	824,4	12,5	23,5	570	940	8	0,38	1,77	2,64	1,73
	9,5	824,4	12,5	23,5	570	940	8	0,38	1,77	2,64	1,73
560	3	644,6	6,3	12,2	542	638	2,5	0,15	4,47	6,65	4,37
	5	693,4	12,5	23,5	578	732	4	0,17	3,95	5,88	3,86
	6	745	12,5	23,5	583	797	5	0,22	3,1	4,62	3,03
	6	732,1	12,5	23,5	583	797	5	0,28	2,39	3,56	2,34
	6	732,1	12,5	23,5	583	797	5	0,28	2,39	3,56	2,34
	7,5	806,6	12,5	23,5	592	888	6	0,29	2,32	3,45	2,26
	7,5	791,5	12,5	23,5	592	888	6	0,37	1,83	2,72	1,79
	9,5	868,1	12,5	23,5	600	990	8	0,38	1,78	2,65	1,74
	9,5	868,1	12,5	23,5	600	990	8	0,38	1,78	2,65	1,74
600	3	696,3	6,3	12,2	612,4	717,6	2,5	0,12	5,78	8,61	5,65
	3	696,3	6,3	12,2	612,4	717,6	2,5	0,12	5,78	8,61	5,65
	3	691,5	6,3	12,2	612,4	717,6	2,5	0,15	4,4	6,56	4,31
	5	740,5	12,5	23,5	618	782	4	0,17	3,95	5,88	3,86
	6	793,3	12,5	23,5	623	847	5	0,21	3,24	4,82	3,16
	6	778,4	12,5	23,5	623	847	5	0,28	2,41	3,59	2,35
	6	778,4	12,5	23,5	623	847	5	0,28	2,41	3,59	2,35
	7,5	852,6	12,5	23,5	632	948	6	0,31	2,2	3,27	2,15
	7,5	833	12,5	23,5	632	948	6	0,38	1,79	2,67	1,75
	9,5	919,5	12,5	23,5	640	1050	8	0,37	1,83	2,72	1,79
	9,5	919,5	12,5	23,5	640	1050	8	0,37	1,83	2,72	1,79



Spherical roller bearings

With cylindrical or tapered bore

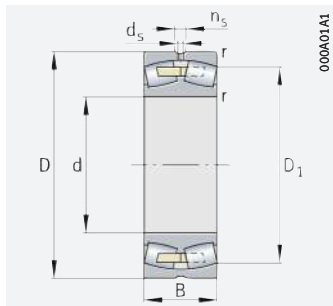

Solid cage, brass or steel; cylindrical bore

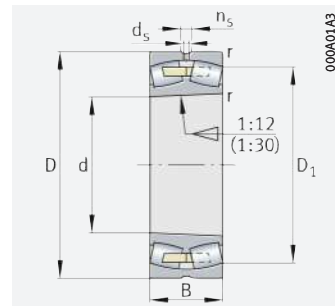

Solid cage, brass or steel; tapered bore

d = 630 – 670 mm

Main dimensions			Basic load ratings		Fatigue limit load	Limiting speed	Speed rating	Mass	Designation
d	D	B	dyn. C_r	stat. C_{0r}	C_{ur}	n_G	$n_{\theta r}$	m	▶ 681 1.12 ▶ 683 1.13 X-life ▶ 671
			kN	kN	N	min^{-1}	min^{-1}	≈ kg	
630	780	112	2 650	6 400	580 000	860	410	120	238/630-XL-K-MA1
	780	112	2 650	6 400	580 000	860	410	122	238/630-XL-MA1
	780	150	3 200	9 000	560 000	700	209	163	248/630-MB
	850	165	4 100	9 900	710 000	740	405	292	239/630-B-MB
	920	212	7 400	13 700	1 120 000	670	380	491	230/630-BEA-XL-MB1
	920	290	9 400	18 600	1 370 000	550	265	656	240/630-BEA-XL-MB1
	1 030	315	9 800	20 700	1 420 000	530	255	1 037	231/630-B-K-MB
	1 030	315	9 800	20 700	1 420 000	530	255	1 074	231/630-B-MB
	1 030	400	13 100	29 500	1 990 000	440	136	1 393	241/630-B-MB
	1 150	412	14 400	28 500	1 350 000	465	181	1 910	232/630-B-K-MB
	1 150	412	14 400	28 500	1 350 000	465	181	1 940	232/630-B-MB
670	820	112	2 380	6 900	445 000	810	380	124	238/670-B-K-MB
	820	112	2 380	6 900	445 000	810	380	129	238/670-B-MB
	820	150	3 350	9 700	590 000	670	191	175	248/670-B-MB
	900	170	4 300	10 600	750 000	710	375	310	239/670-B-K-MB
	900	170	4 300	10 600	750 000	710	375	320	239/670-B-MB
	900	230	5 900	14 900	940 000	580	174	429	249/670-B-K30-MB
	900	230	5 900	14 900	940 000	580	174	433	249/670-B-MB
	980	230	7 200	15 800	1 100 000	630	350	590	230/670-B-K-MB
	980	230	7 200	15 800	1 100 000	630	350	600	230/670-B-MB
	980	308	9 000	21 500	1 480 000	510	239	794	240/670-B-K30-MB
	980	308	9 000	21 500	1 480 000	510	239	813	240/670-B-MB
	1 090	336	11 000	23 900	1 560 000	495	230	1 241	231/670-B-K-MB
	1 090	336	11 000	23 900	1 560 000	495	230	1 279	231/670-B-MB
	1 090	412	14 000	31 500	2 110 000	420	127	1 539	241/670-B-K30-MB
	1 090	412	14 000	31 500	2 110 000	420	127	1 544	241/670-B-MB
	1 220	438	16 000	32 000	2 130 000	430	165	2 246	232/670-B-K-MB
		1 220	438	16 000	32 000	2 130 000	430	165	2 317

medias ▶ <https://www.schaeffler.de/std/1EDF>

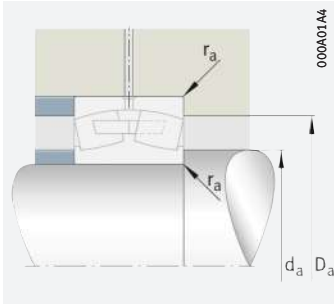

Mounting dimensions

Dimensions					Mounting dimensions			Calculation factors			
d	r	D ₁	d _s	n _s	d _a	D _a	r _a	e	Y ₁	Y ₂	Y ₀
	min.	≈			min.	max.	max.				
630	4	736,8	8	15	644,6	765,4	3	0,12	5,51	8,21	5,39
	4	736,8	8	15	644,6	765,4	3	0,12	5,51	8,21	5,39
	4	734,2	8	15	645	765	3	0,17	3,95	5,88	3,86
	6	784,5	12,5	23,5	653	827	5	0,18	3,8	5,66	3,72
	7,5	837,8	12,5	23,5	658	892	6	0,21	3,24	4,82	3,16
	7,5	821,5	12,5	23,5	658	892	6	0,28	2,39	3,56	2,34
	7,5	896,2	12,5	23,5	662	998	6	0,31	2,21	3,29	2,16
	7,5	896,15	12,5	23,5	662	998	6	0,31	2,21	3,29	2,16
	7,5	872,2	12,5	23,5	662	998	6	0,38	1,78	2,65	1,74
	12	969,2	12,5	23,5	678	1102	10	0,37	1,8	2,69	1,76
	12	969,2	12,5	23,5	678	1102	10	0,37	1,8	2,69	1,76
	670	4	777,2	8	15	684,6	805,4	3	0,12	5,72	8,51
4		777,2	8	15	684,6	805,4	3	0,12	5,72	8,51	5,59
4		775,2	8	15	684,6	805,4	3	0,16	4,22	6,29	4,13
6		831,5	12,5	23,5	693	877	5	0,17	3,95	5,88	3,86
6		831,5	12,5	23,5	693	877	5	0,17	3,95	5,88	3,86
6		826,5	12,5	23,5	693	877	5	0,24	2,81	4,19	2,75
6		826,5	12,5	23,5	693	877	5	0,24	2,81	4,19	2,75
7,5		888,7	12,5	23,5	698	952	6	0,22	3,01	4,48	2,94
7,5		888,7	12,5	23,5	698	952	6	0,22	3,01	4,48	2,94
7,5		873,1	12,5	23,5	698	952	6	0,31	2,2	3,27	2,15
7,5		873,1	12,5	23,5	698	952	6	0,31	2,2	3,27	2,15
7,5		948,2	12,5	23,5	702	1058	6	0,31	2,21	3,29	2,16
7,5		948,15	12,5	23,5	702	1058	6	0,31	2,21	3,29	2,16
7,5		929,4	12,5	23,5	702	1058	6	0,37	1,83	2,72	1,79
7,5		929,4	12,5	23,5	702	1058	6	0,37	1,83	2,72	1,79
12		1030,7	12,5	23,5	718	1172	10	0,37	1,82	2,7	1,78
12		1030,7	12,5	23,5	718	1172	10	0,37	1,82	2,7	1,78



Spherical roller bearings

With cylindrical or tapered bore

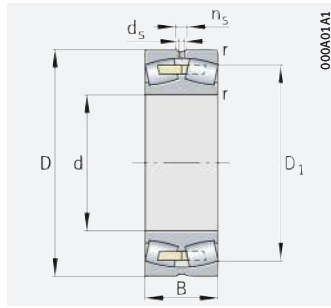

Solid cage, brass or steel; cylindrical bore

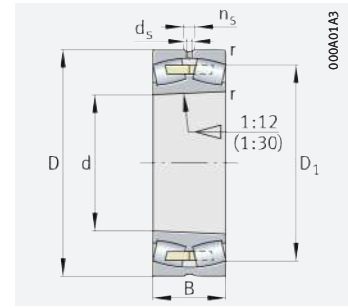

Solid cage, brass or steel; tapered bore

d = 710 – 750 mm

Main dimensions			Basic load ratings		Fatigue limit load	Limiting speed	Speed rating	Mass	Designation
d	D	B	dyn. C _r kN	stat. C _{0r} kN	C _{ur} N	n _G min ⁻¹	n _{θr} min ⁻¹	m ≈ kg	▶ 681 1.12 ▶ 683 1.13
710	870	118	2 650	7 500	540 000	770	355	148	238/710-K-MB
	870	118	2 650	7 500	540 000	770	355	153	238/710-MB
	870	160	3 700	11 000	780 000	610	175	215	248/710-B-MB
	950	180	4 800	12 100	720 000	670	350	336	239/710-K-MB
	950	180	4 800	12 100	720 000	670	350	355	239/710-MB
	950	243	6 600	16 900	1 060 000	550	159	488	249/710-B-K30-MB
	950	243	6 600	16 900	1 060 000	550	159	494	249/710-B-MB
	1030	236	7 600	16 900	1 150 000	590	325	650	230/710-B-K-MB
	1030	236	7 600	16 900	1 150 000	590	325	678	230/710-B-MB
	1030	315	9 600	23 000	1 560 000	480	223	873	240/710-B-K30-MB
	1030	315	9 600	23 000	1 560 000	480	223	903	240/710-B-MB
	1150	345	12 500	27 000	1 790 000	470	207	1 417	231/710-B-K-MB
	1150	345	12 500	27 000	1 790 000	470	207	1 450	231/710-B-MB
	1150	438	15 600	35 500	2 290 000	395	116	1 791	241/710-B-K30-MB
1150	438	15 600	35 500	2 290 000	395	116	1 818	241/710-B-MB	
1280	450	17 200	35 500	2 320 000	405	149	2 541	232/710-B-K-MB	
1280	450	17 200	35 500	2 320 000	405	149	2 614	232/710-B-MB	
750	920	128	3 000	8 700	600 000	720	330	180	238/750-B-K-MB
	920	128	3 000	8 700	600 000	720	330	186	238/750-B-MB
	920	170	4 150	12 500	740 000	570	160	254	248/750-B-MB
	1000	185	5 200	13 000	790 000	640	325	394	239/750-K-MB
	1000	185	5 200	13 000	790 000	640	325	426	239/750-MB
	1000	250	7 200	18 900	1 170 000	510	143	558	249/750-B-K30-MB
	1000	250	7 200	18 900	1 170 000	510	143	571	249/750-B-MB
	1090	250	8 500	19 100	1 010 000	550	305	786	230/750-K-MB
	1090	250	8 500	19 100	1 010 000	550	305	806	230/750-MB
	1090	335	10 800	26 000	1 740 000	445	204	1 071	240/750-B-K30-MB
	1090	335	10 800	26 000	1 740 000	445	204	1 057	240/750-B-MB
	1220	365	14 100	30 500	1 970 000	445	189	1 700	231/750-B-K-MB
	1220	365	14 100	30 500	1 970 000	445	189	1 754	231/750-B-MB
	1220	475	17 800	41 000	2 600 000	360	104	2 298	241/750-B-K30-MB
	1220	475	17 800	41 000	2 600 000	360	104	2 276	241/750-B-MB
	1360	475	19 300	39 500	2 500 000	380	137	3 087	232/750-B-K-MB
	1360	475	19 300	39 500	2 500 000	380	137	3 136	232/750-B-MB

medias ▶ <https://www.schaeffler.de/std/1EE0>

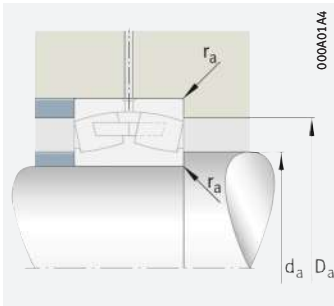

Mounting dimensions

Dimensions					Mounting dimensions			Calculation factors			
d	r	D ₁	d _s	n _s	d _a	D _a	r _a	e	Y ₁	Y ₂	Y ₀
	min.	≈			min.	max.	max.				
710	4	824,9	8	15	724,6	855,4	3	0,12	5,72	8,51	5,59
	4	824,9	8	15	724,6	855,4	3	0,12	5,72	8,51	5,59
	4	821,2	8	15	725	855	3	0,16	4,22	6,29	4,13
	6	877,5	12,5	23,5	733	927	5	0,18	3,85	5,73	3,76
	6	877,5	12,5	23,5	733	927	5	0,18	3,85	5,73	3,76
	6	871,7	12,5	23,5	733	927	5	0,24	2,81	4,19	2,75
	6	871,7	12,5	23,5	733	927	5	0,24	2,81	4,19	2,75
	7,5	938,8	12,5	23,5	738	1002	6	0,22	3,07	4,57	3
	7,5	938,8	12,5	23,5	738	1002	6	0,22	3,07	4,57	3
	7,5	921,6	12,5	23,5	738	1002	6	0,3	2,26	3,37	2,21
	7,5	921,6	12,5	23,5	738	1002	6	0,3	2,26	3,37	2,21
	9,5	1006,6	12,5	23,5	750	1110	8	0,3	2,25	3,34	2,2
	9,5	1006,55	12,5	23,5	750	1110	8	0,3	2,25	3,34	2,2
	9,5	980,2	12,5	23,5	750	1110	8	0,38	1,79	2,67	1,75
	9,5	980,2	12,5	23,5	750	1110	8	0,38	1,79	2,67	1,75
	12	1088,4	12,5	23,5	758	1232	10	0,37	1,83	2,72	1,79
12	1088,4	12,5	23,5	758	1232	10	0,37	1,83	2,72	1,79	
750	5	872,1	8	15	768	902	4	0,12	5,61	8,36	5,49
	5	872,1	8	15	768	902	4	0,12	5,61	8,36	5,49
	5	868,2	8	15	768	902	4	0,16	4,11	6,12	4,02
	6	923,2	12,5	23,5	773	977	5	0,17	3,95	5,88	3,86
	6	923,2	12,5	23,5	773	977	5	0,17	3,95	5,88	3,86
	6	921,7	12,5	23,5	773	977	5	0,22	3,1	4,62	3,03
	6	921,7	12,5	23,5	773	977	5	0,22	3,1	4,62	3,03
	7,5	990,9	12,5	23,5	778	1062	6	0,22	3,01	4,48	2,94
	7,5	990,9	12,5	23,5	778	1062	6	0,22	3,01	4,48	2,94
	7,5	976,2	12,5	23,5	778	1062	6	0,3	2,26	3,37	2,21
	7,5	976,2	12,5	23,5	778	1062	6	0,3	2,26	3,37	2,21
	9,5	1067,4	12,5	23,5	790	1180	8	0,29	2,3	3,42	2,25
	9,5	1067,37	12,5	23,5	790	1180	8	0,29	2,3	3,42	2,25
	9,5	1035,8	12,5	23,5	790	1180	8	0,38	1,76	2,62	1,72
	9,5	1035,8	12,5	23,5	790	1180	8	0,38	1,76	2,62	1,72
	15	1154,1	12,5	23,5	808	1302	12	0,37	1,83	2,72	1,79
15	1154,1	12,5	23,5	808	1302	12	0,37	1,83	2,72	1,79	





Spherical roller bearings

With cylindrical or tapered bore

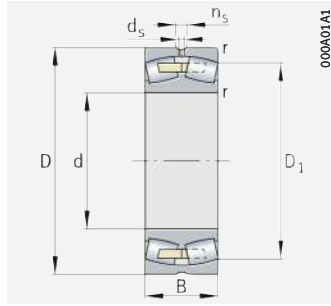

Solid cage, brass or steel;
cylindrical bore

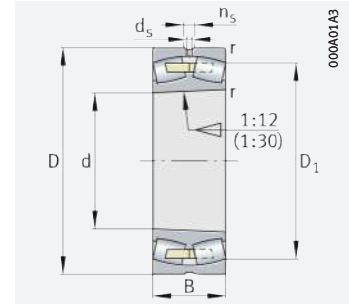

Solid cage, brass or steel;
tapered bore

d = 800 – 850 mm

Main dimensions			Basic load ratings		Fatigue limit load	Limiting speed	Speed rating	Mass	Designation
d	D	B	dyn. C _r kN	stat. C _{0r} kN	C _{ur} N	n _G min ⁻¹	n _{θr} min ⁻¹	m ≈ kg	▶ 681 1.12 ▶ 683 1.13
800	980	136	3 400	9 900	680 000	660	305	216	238/800-B-K-MB
	980	136	3 400	9 900	680 000	660	305	223	238/800-B-MB
	980	180	4 650	14 000	830 000	540	146	301	248/800-B-MB
	1060	195	5 900	15 100	1 010 000	580	295	490	239/800-B-K-MB
	1060	195	5 900	15 100	1 010 000	580	295	506	239/800-B-MB
	1060	258	7 700	20 300	1 360 000	480	133	639	249/800-B-K30-MB
	1060	258	7 700	20 300	1 360 000	480	133	650	249/800-B-MB
	1150	258	9 300	21 200	1 420 000	530	280	877	230/800-K-MB
	1150	258	9 300	21 200	1 420 000	530	280	899	230/800-MB
	1150	345	11 600	28 500	1 790 000	420	188	1 186	240/800-B-K30-MB
	1150	345	11 600	28 500	1 790 000	420	188	1 199	240/800-B-MB
	1280	375	14 900	33 500	1 660 000	415	175	1 861	231/800-K-MB
	1280	375	14 900	33 500	1 660 000	415	175	1 968	231/800-MB
	1280	475	18 700	43 500	2 430 000	345	96	2 530	241/800-B-K30-MB
1280	475	18 700	43 500	2 430 000	345	96	2 530	241/800-B-MB	
1420	488	20 000	41 500	1 540 000	365	130	3 325	232/800-K-MB	
1420	488	20 000	41 500	1 540 000	365	130	3 377	232/800-MB	
850	1030	136	3 500	10 600	710 000	620	285	228	238/850-K-MB
	1030	136	3 500	10 600	710 000	620	285	236	238/850-MB
	1030	180	4 850	14 900	880 000	510	135	312	248/850-MB
	1120	200	6 300	16 400	960 000	550	275	554	239/850-K-MB
	1120	200	6 300	16 400	960 000	550	275	579	239/850-MB
	1120	272	8 400	22 500	1 370 000	445	123	743	249/850-B-K30-MB
	1120	272	8 400	22 500	1 370 000	445	123	756	249/850-B-MB
	1220	272	10 300	23 800	1 540 000	490	255	1 035	230/850-B-K-MB
	1220	272	10 300	23 800	1 540 000	490	255	1 078	230/850-B-MB
	1220	365	12 800	32 000	2 060 000	390	173	1 415	240/850-B-K30-MB
	1220	365	12 800	32 000	2 060 000	390	173	1 438	240/850-B-MB
	1360	400	16 100	36 000	2 290 000	385	164	2 245	231/850-B-K-MB
	1360	400	16 100	36 000	2 290 000	385	164	2 396	231/850-B-MB
	1360	500	21 200	48 500	3 050 000	330	88	2 836	241/850-B-K30-MB
1360	500	21 200	48 500	3 050 000	330	88	2 948	241/850-B-MB	

medias ▶ <https://www.schaeffler.de/std/1EE1>

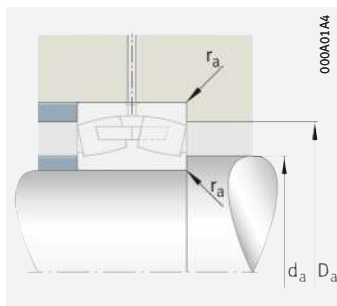

Mounting dimensions

Dimensions					Mounting dimensions			Calculation factors			
d	r	D ₁	d _s	n _s	d _a	D _a	r _a	e	Y ₁	Y ₂	Y ₀
	min.	≈			min.	max.	max.				
800	5	927,6	8	15	818	962	4	0,12	5,72	8,51	5,59
	5	927,6	8	15	818	962	4	0,12	5,72	8,51	5,59
	5	925,4	8	15	818	962	4	0,16	4,11	6,12	4,02
	6	983,7	12,5	23,5	823	1 037	5	0,17	4,05	6,04	3,96
	6	983,7	12,5	23,5	823	1 037	5	0,17	4,05	6,04	3,96
	6	978,6	12,5	23,5	823	1 037	5	0,23	2,98	4,44	2,92
	6	978,6	12,5	23,5	823	1 037	5	0,23	2,98	4,44	2,92
	7,5	1 050,9	12,5	23,5	828	1 122	6	0,22	3,07	4,57	3
	7,5	1 050,9	12,5	23,5	828	1 122	6	0,22	3,07	4,57	3
	7,5	1 034,1	12,5	23,5	828	1 122	6	0,29	2,33	3,47	2,28
	7,5	1 034,1	12,5	23,5	828	1 122	6	0,29	2,33	3,47	2,28
	9,5	1 119,1	12,5	23,5	840	1 240	8	0,29	2,32	3,45	2,26
	9,5	1 119,05	12,5	23,5	840	1 240	8	0,29	2,32	3,45	2,26
	9,5	1 099,5	12,5	23,5	840	1 240	8	0,36	1,86	2,77	1,82
	9,5	1 099,5	12,5	23,5	840	1 240	8	0,36	1,86	2,77	1,82
15	1 211,4	12,5	23,5	858	1 362	12	0,36	1,87	2,79	1,83	
15	1 211,4	12,5	23,5	858	1 362	12	0,36	1,87	2,79	1,83	
850	5	978,1	8	15	868	1 012	4	0,11	6,06	9,02	5,92
	5	978,1	8	15	868	1 012	4	0,11	6,06	9,02	5,92
	5	973,9	8	15	868	1 012	4	0,15	4,4	6,56	4,31
	6	1 039,9	12,5	23,5	873	1 097	5	0,16	4,11	6,12	4,02
	6	1 039,9	12,5	23,5	873	1 097	5	0,16	4,11	6,12	4,02
	6	1 033,9	12,5	23,5	873	1 097	5	0,23	2,98	4,44	2,92
	6	1 033,9	12,5	23,5	873	1 097	5	0,23	2,98	4,44	2,92
	7,5	1 113,5	12,5	23,5	878	1 192	6	0,21	3,24	4,82	3,16
	7,5	1 113,5	12,5	23,5	878	1 192	6	0,21	3,24	4,82	3,16
	7,5	1 092,9	12,5	23,5	878	1 192	6	0,29	2,33	3,47	2,28
	7,5	1 092,9	12,5	23,5	878	1 192	6	0,29	2,33	3,47	2,28
	12	1 197,2	12,5	23,5	898	1 312	10	0,29	2,35	3,5	2,3
	12	1 197,2	12,5	23,5	898	1 312	10	0,29	2,35	3,5	2,3
	12	1 171,7	12,5	23,5	898	1 312	10	0,36	1,89	2,81	1,84
	12	1 171,7	12,5	23,5	898	1 312	10	0,36	1,89	2,81	1,84





Spherical roller bearings

With cylindrical or tapered bore

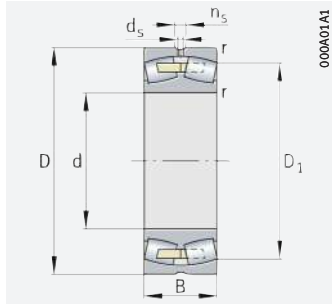

Solid cage, brass or steel; cylindrical bore

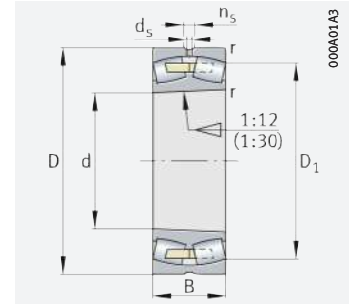

Solid cage, brass or steel; tapered bore

d = 900 – 950 mm

Main dimensions			Basic load ratings		Fatigue limit load	Limiting speed	Speed rating	Mass	Designation
d	D	B	dyn. C _r kN	stat. C _{0r} kN	C _{ur} N	n _G min ⁻¹	n _{θr} min ⁻¹	m ≈ kg	▶ 681 1.12 ▶ 683 1.13
900	1090	140	3 750	11 600	760 000	590	260	262	238/900-B-K-MB
	1090	140	3 750	11 600	760 000	590	260	271	238/900-B-MB
	1090	190	5 200	16 700	960 000	465	124	382	248/900-B-MB
	1180	206	6 500	17 200	1 010 000	520	260	641	239/900-K-MB
	1180	206	6 500	17 200	1 010 000	520	260	653	239/900-MB
	1280	280	11 100	26 500	1 620 000	455	235	1 153	230/900-B-K-MB
	1280	280	11 100	26 500	1 620 000	455	235	1 228	230/900-B-MB
	1280	375	14 200	36 500	2 220 000	365	155	1 569	240/900-B-K30-MB
	1280	375	14 200	36 500	2 220 000	365	155	1 595	240/900-B-MB
	1420	412	18 000	40 500	2 550 000	365	149	2 469	231/900-B-K-MB
	1420	412	18 000	40 500	2 550 000	365	149	2 570	231/900-B-MB
	1420	515	22 300	53 000	2 900 000	310	81	3 130	241/900-B-FB1
1420	515	22 300	53 000	2 900 000	310	81	3 130	241/900-B-K30-FB1	
950	1150	200	5 700	18 500	1 030 000	430	114	431	248/950-MB
	1250	224	7 500	19 900	1 280 000	475	239	747	239/950-B-K-MB
	1250	224	7 500	19 900	1 280 000	475	239	769	239/950-B-MB
	1250	300	10 300	28 500	1 700 000	385	101	1 013	249/950-B-K30-MB
	1250	300	10 300	28 500	1 700 000	385	101	1 031	249/950-B-MB
	1360	300	12 300	29 500	1 800 000	425	218	1 421	230/950-B-K-MB
	1360	300	12 300	29 500	1 800 000	425	218	1 493	230/950-B-MB
	1360	412	16 200	42 000	2 550 000	335	142	1 973	240/950-B-K30-MB
	1360	412	16 200	42 000	2 550 000	335	142	1 993	240/950-B-MB
	1500	545	23 700	54 000	3 100 000	300	81	3 777	241/950-B-K30-MB
	1500	545	23 700	54 000	3 100 000	300	81	3 819	241/950-B-MB

medias ▶ <https://www.schaeffler.de/std/1EE2>

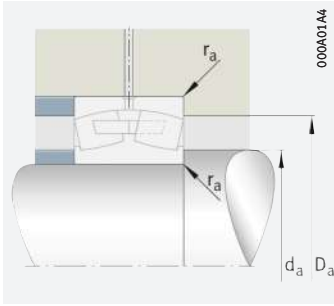

Mounting dimensions

Dimensions					Mounting dimensions			Calculation factors			
d	r	D ₁	d _s	n _s	d _a	D _a	r _a	e	Y ₁	Y ₂	Y ₀
	min.	≈			min.	max.	max.				
900	5	1 036,1	8	15	918	1 072	4	0,11	6,06	9,02	5,92
	5	1 036,1	8	15	918	1 072	4	0,11	6,06	9,02	5,92
	5	1 030,5	8	15	918	1 072	4	0,15	4,4	6,56	4,31
	6	1 098,8	12,5	23,5	923	1 157	5	0,16	4,28	6,37	4,19
	6	1 098,8	12,5	23,5	923	1 157	5	0,16	4,28	6,37	4,19
	7,5	1 171,3	12,5	23,5	928	1 252	6	0,22	3,14	4,67	3,07
	7,5	1 171,3	12,5	23,5	928	1 252	6	0,22	3,14	4,67	3,07
	7,5	1 150,7	12,5	23,5	928	1 252	6	0,28	2,45	3,64	2,39
	7,5	1 150,7	12,5	23,5	928	1 252	6	0,28	2,45	3,64	2,39
	12	1 252,4	12,5	23,5	948	1 372	10	0,29	2,33	3,47	2,28
	12	1 252,35	12,5	23,5	948	1 372	10	0,29	2,33	3,47	2,28
	12	1 230,4	12,5	23,5	948	1 372	10	0,35	1,91	2,85	1,87
12	1 230,4	12,5	23,5	948	1 372	10	0,35	1,91	2,85	1,87	
950	5	1 087,2	8	15	968	1 132	4	0,15	4,4	6,56	4,31
	7,5	1 162,5	12,5	23,5	978	1 222	6	0,16	4,22	6,29	4,13
	7,5	1 162,5	12,5	23,5	978	1 222	6	0,16	4,22	6,29	4,13
	7,5	1 155	12,5	23,5	978	1 222	6	0,22	3,01	4,48	2,94
	7,5	1 155	12,5	23,5	978	1 222	6	0,22	3,01	4,48	2,94
	7,5	1 244,7	12,5	23,5	978	1 332	6	0,22	3,14	4,67	3,07
	7,5	1 244,7	12,5	23,5	978	1 332	6	0,22	3,14	4,67	3,07
	7,5	1 216	12,5	23,5	978	1 332	6	0,28	2,37	3,53	2,32
	7,5	1 216	12,5	23,5	978	1 332	6	0,28	2,37	3,53	2,32
	12	1 306,7	12,5	23,5	998	1 452	10	0,36	1,87	2,79	1,83
	12	1 306,7	12,5	23,5	998	1 452	10	0,36	1,87	2,79	1,83





Spherical roller bearings

With cylindrical or tapered bore

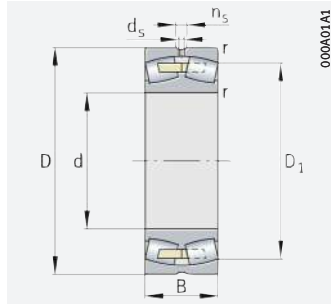

Solid cage, brass or steel;
cylindrical bore

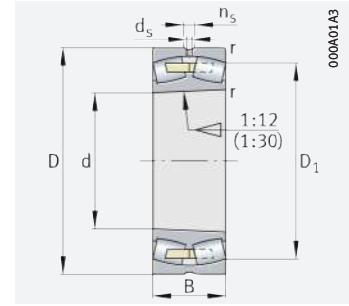

Solid cage, brass or steel;
tapered bore

d = 1 000 – 1 120 mm

Main dimensions			Basic load ratings		Fatigue limit load	Limiting speed	Speed rating	Mass	Designation
d	D	B	dyn. C _r kN	stat. C _{0r} kN	C _{ur} N	n _G min ⁻¹	n _{Dr} min ⁻¹	m ≈ kg	▶ 681 1.12 ▶ 683 1.13
1 000	1 220	165	4 900	14 900	960 000	510	231	399	238/1000-K-MB
	1 220	165	4 900	14 900	960 000	510	231	413	238/1000-MB
	1 220	218	6 700	21 500	1 210 000	405	104	546	248/1000-B-MB
	1 320	315	11 400	31 000	1 850 000	370	95	1 192	249/1000-B-K30-MB
	1 320	315	11 400	31 000	1 850 000	370	95	1 212	249/1000-B-MB
	1 420	308	13 100	31 500	1 580 000	405	206	1 590	230/1000-K-MB
	1 420	308	13 100	31 500	1 580 000	405	206	1 590	230/1000-MB
	1 420	412	16 400	42 000	2 550 000	330	138	2 073	240/1000-B-K30-MB
	1 420	412	16 400	42 000	2 550 000	330	138	2 108	240/1000-B-MB
	1 580	462	22 000	51 000	3 150 000	320	126	3 474	231/1000-B-K-MB
	1 580	462	22 000	51 000	3 150 000	320	126	3 474	231/1000-B-MB
	1 580	580	27 500	64 000	3 950 000	275	70	4 379	241/1000-B-K30-MB
1 580	580	27 500	64 000	3 950 000	275	70	4 429	241/1000-B-MB	
1 060	1 280	165	5 100	16 100	980 000	480	213	421	238/1060-B-K-MB
	1 280	165	5 100	16 100	980 000	480	213	435	238/1060-B-MB
	1 280	218	7 000	22 700	1 270 000	385	97	599	248/1060-B-MB
	1 400	250	9 900	26 000	1 420 000	420	202	1 060	239/1060-K-MB1
	1 400	250	9 900	26 000	1 420 000	420	202	1 081	239/1060-MB1
	1 400	335	12 900	36 000	2 240 000	345	84	1 411	249/1060-B-K30-MB
	1 400	335	12 900	36 000	2 240 000	345	84	1 436	249/1060-B-MB
	1 500	325	13 700	34 000	2 110 000	375	193	1 896	230/1060-B-MB
	1 500	438	18 800	49 500	2 950 000	295	122	2 483	240/1060-B-K30-MB
	1 500	438	18 800	49 500	2 950 000	295	122	2 524	240/1060-B-MB
1 120	1 360	243	8 000	26 000	1 460 000	365	90	791	248/1120-B-MB
	1 460	335	12 800	35 500	2 180 000	340	83	1 518	249/1120-B-K30-MB
	1 460	335	12 800	35 500	2 180 000	340	83	1 545	249/1120-B-MB
	1 580	345	14 900	37 500	2 250 000	350	181	2 210	230/1120-B-MB
	1 580	462	20 900	55 000	3 250 000	280	113	2 889	240/1120-B-K30-MB
	1 580	462	20 900	55 000	3 250 000	280	113	2 924	240/1120-B-MB

medias ▶ <https://www.schaeffler.de/std/1EE3>

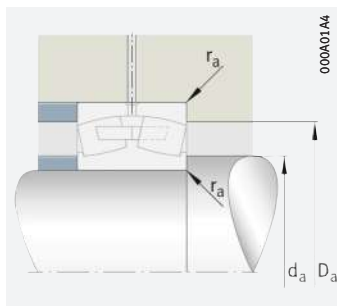

Mounting dimensions

Dimensions					Mounting dimensions			Calculation factors			
d	r	D ₁	d _s	n _s	d _a	D _a	r _a	e	Y ₁	Y ₂	Y ₀
	min.	≈			min.	max.	max.				
1 000	6	1 158	9,5	17,7	1 023	1 197	5	0,12	5,72	8,51	5,59
	6	1 158	9,5	17,7	1 023	1 197	5	0,12	5,72	8,51	5,59
	6	1 151,4	9,5	17,7	1 023	1 197	5	0,16	4,28	6,37	4,19
	7,5	1 218,4	12,5	23,5	1 028	1 292	6	0,22	3,01	4,48	2,94
	7,5	1 218,4	12,5	23,5	1 028	1 292	6	0,22	3,01	4,48	2,94
	7,5	1 300,3	12,5	23,5	1 028	1 392	6	0,21	3,2	4,77	3,13
	7,5	1 300,3	12,5	23,5	1 028	1 392	6	0,21	3,2	4,77	3,13
	7,5	1 278,3	12,5	23,5	1 028	1 392	6	0,28	2,41	3,59	2,35
	7,5	1 278,3	12,5	23,5	1 028	1 392	6	0,28	2,41	3,59	2,35
	12	1 391,8	12,5	23,5	1 048	1 532	10	0,29	2,33	3,47	2,28
	12	1 391,78	12,5	23,5	1 048	1 532	10	0,29	2,33	3,47	2,28
	12	1 372,6	12,5	23,5	1 048	1 532	10	0,35	1,91	2,85	1,87
12	1 372,6	12,5	23,5	1 048	1 532	10	0,35	1,91	2,85	1,87	
1 060	6	1 218,6	9,5	17,7	1 083	1 257	5	0,11	6,18	9,2	6,04
	6	1 218,6	9,5	17,7	1 083	1 257	5	0,11	6,18	9,2	6,04
	6	1 212,7	9,5	17,7	1 083	1 257	5	0,15	4,54	6,75	4,43
	7,5	1 307,6	12,5	23,5	1 088	1 372	6	0,17	4,05	6,04	3,96
	7,5	1 307,6	12,5	23,5	1 088	1 372	6	0,17	4,05	6,04	3,96
	7,5	1 290,7	12,5	23,5	1 088	1 372	6	0,21	3,17	4,72	3,1
	7,5	1 290,7	12,5	23,5	1 088	1 372	6	0,21	3,17	4,72	3,1
	9,5	1 374,6	12,5	23,5	1 094	1 466	8	0,2	3,38	5,03	3,3
	9,5	1 353,5	12,5	23,5	1 094	1 466	8	0,27	2,47	3,67	2,41
	9,5	1 353,5	12,5	23,5	1 094	1 466	8	0,27	2,47	3,67	2,41
1 120	6	1 285	9,5	17,7	1 143	1 337	5	0,15	4,47	6,65	4,37
	7,5	1 352,6	12,5	23,5	1 148	1 432	6	0,21	3,27	4,87	3,2
	7,5	1 352,6	12,5	23,5	1 148	1 432	6	0,21	3,27	4,87	3,2
	9,5	1 445,4	12,5	23,5	1 154	1 546	8	0,2	3,42	5,09	3,34
	9,5	1 429,7	12,5	23,5	1 154	1 546	8	0,28	2,45	3,64	2,39
	9,5	1 429,7	12,5	23,5	1 154	1 546	8	0,28	2,45	3,64	2,39





Spherical roller bearings

With cylindrical or tapered bore

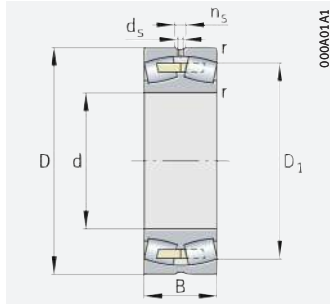

Solid cage, brass or steel;
cylindrical bore

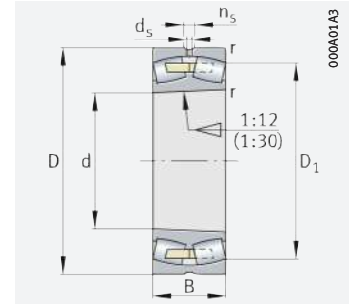

Solid cage, brass or steel;
tapered bore

d = 1 180 – 1 800 mm

Main dimensions			Basic load ratings		Fatigue limit load	Limiting speed	Speed rating	Mass	Designation
d	D	B	dyn. C _r kN	stat. C _{0r} kN	C _{ur} N	n _G min ⁻¹	n _{Dr} min ⁻¹	m ≈ kg	
1 180	1 420	180	6 000	19 200	1 110 000	430	187	556	238/1180-B-K-MB
	1 420	180	6 000	19 200	1 110 000	430	187	576	238/1180-B-MB
	1 420	243	8 400	28 000	1 540 000	335	83	790	248/1180-B-MB
	1 540	272	11 300	31 000	1 770 000	370	177	1 340	239/1180-B-K-MB
	1 540	272	11 300	31 000	1 770 000	370	177	1 385	239/1180-B-MB
	1 540	355	14 700	42 000	2 400 000	305	73	1 751	249/1180-B-K30-MB
	1 540	355	14 700	42 000	2 400 000	305	73	1 788	249/1180-B-MB
	1 660	355	16 600	42 000	2 470 000	330	166	2 513	230/1180-B-MB
1 250	1 500	250	9 000	30 500	1 220 000	320	76	918	248/1250-B-MB
	1 630	375	16 000	45 500	2 700 000	295	69	2 096	249/1250-B-K30-MB
	1 630	375	16 000	45 500	2 700 000	295	69	2 132	249/1250-B-MB
	1 750	375	18 100	46 500	2 700 000	310	154	2 923	230/1250-B-K-MB
	1 750	375	18 100	46 500	2 700 000	310	154	2 933	230/1250-B-MB
1 320	1 600	280	10 300	35 000	1 900 000	295	71	1 235	248/1320-B-MB
	1 720	400	17 600	52 000	2 370 000	265	62	2 515	249/1320-B-K30-MB
	1 720	400	17 600	52 000	2 370 000	265	62	2 558	249/1320-B-MB
1 400	1 700	300	12 100	41 000	2 220 000	270	63	1 470	248/1400-B-MB
1 500	1 820	315	13 000	44 500	2 380 000	255	58	1 660	248/1500-B-MB
1 600	1 950	345	16 000	54 000	3 000 000	240	51	2 222	248/1600-B-MB
1 700	2 060	355	17 100	60 000	2 850 000	218	46	2 573	248/1700-MB
1 800	2 180	375	18 700	67 000	3 400 000	201	42	2 992	248/1800-B-MB

medias ► <https://www.schaeffler.de/std/1EE4>

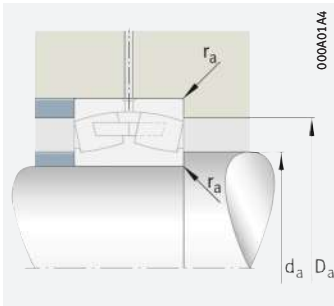

Mounting dimensions

Dimensions					Mounting dimensions			Calculation factors			
d	r	D ₁	d _s	n _s	d _a	D _a	r _a	e	Y ₁	Y ₂	Y ₀
	min.	≈			min.	max.	max.				
1 180	6	1 353,9	9,5	17,7	1 203	1 397	5	0,11	6,18	9,2	6,04
	6	1 353,9	9,5	17,7	1 203	1 397	5	0,11	6,18	9,2	6,04
	6	1 345	9,5	17,7	1 203	1 397	5	0,15	4,54	6,75	4,43
	7,5	1 438,3	12,5	23,5	1 208	1 512	6	0,17	4,05	6,04	3,96
	7,5	1 438,3	12,5	23,5	1 208	1 512	6	0,17	4,05	6,04	3,96
	7,5	1 428,9	12,5	23,5	1 208	1 512	6	0,22	3,14	4,67	3,07
	7,5	1 428,9	12,5	23,5	1 208	1 512	6	0,22	3,14	4,67	3,07
	9,5	1 522,2	12,5	23,5	1 214	1 626	8	0,21	3,27	4,87	3,2
1 250	6	1 423,5	9,5	17,7	1 273	1 477	5	0,14	4,67	6,96	4,57
	7,5	1 510,5	12,5	23,5	1 278	1 602	6	0,21	3,24	4,82	3,16
	7,5	1 510,5	12,5	23,5	1 278	1 602	6	0,21	3,24	4,82	3,16
	9,5	1 607,6	12,5	23,5	1 284	1 716	8	0,2	3,34	4,98	3,27
	9,5	1 607,6	12,5	23,5	1 284	1 716	8	0,2	3,34	4,98	3,27
1 320	7,5	1 512,8	12,5	23,5	1 343	1 577	5	0,15	4,4	6,56	4,31
	7,5	1 595,5	12,5	23,5	1 348	1 640	6	0,22	3,1	4,62	3,03
	7,5	1 595,5	12,5	23,5	1 348	1 640	6	0,22	3,1	4,62	3,03
1 400	7,5	1 606,9	12,5	23,5	1 428	1 672	6	0,16	4,34	6,47	4,25
1 500	7,5	1 722,1	12,5	23,5	1 528	1 792	6	0,15	4,47	6,65	4,37
1 600	7,5	1 846,9	12,5	23,5	1 628	1 922	6	0,15	4,54	6,75	4,43
1 700	7,5	1 946,7	12,5	23,5	1 728	2 032	6	0,15	4,47	6,65	4,37
1 800	9,5	2 060	12,5	23,5	1 834	2 146	8	0,15	4,47	6,65	4,37



Spherical roller bearings

Sealed

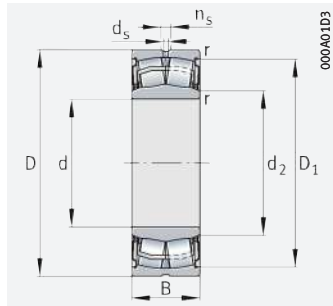

$D \leq 160 \text{ mm}$
with seal 2RSR

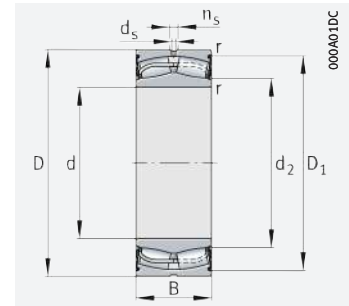

$160 \text{ mm} < D \leq 320 \text{ mm}$
with seal 2VSR

d = 25 – 140 mm

Main dimensions			Basic load ratings		Fatigue limit load C_{ur}	Limiting speed n_G	Mass m	Designation
d	D	B	dyn. C_r	stat. C_{0r}				
			kN	kN	N	min^{-1}	$\approx \text{kg}$	
25	52	23	48,5	42,5	4 800	3 600	0,235	WS22205-E1-XL-2RSR
30	62	25	64	57	6 900	3 150	0,4	WS22206-E1-XL-2RSR
35	72	28	89	81	9 400	2 700	0,6	WS22207-E1-XL-2RSR
40	80	28	101	91	11 800	2 600	0,7	WS22208-E1-XL-2RSR
	90	38	156	149	13 100	1 890	1,16	WS22308-E1-XL-2RSR
45	85	28	104	99	12 700	2 550	0,67	WS22209-E1-XL-2RSR
50	90	28	109	107	14 300	2 440	0,8	WS22210-E1-XL-2RSR
55	100	31	129	130	17 300	2 250	1,1	WS22211-E1-XL-2RSR
	120	49	265	260	23 900	1 460	2,9	WS22311-E1-XL-2RSR
60	110	34	160	155	20 200	2 030	1,5	WS22212-E1-XL-2RSR
	130	53	310	310	28 000	1 350	3,4	WS22312-E1-XL-2RSR
65	120	38	202	210	25 500	1 740	2	WS22213-E1-XL-2RSR
70	125	38	211	226	28 000	1 670	2,1	WS22214-E1-XL-2RSR
	150	60	390	390	36 500	1 210	5,4	WS22314-E1-XL-2RSR
75	130	38	216	237	29 500	1 630	2,2	WS22215-E1-XL-2RSR
80	140	40	250	270	33 500	1 540	2,7	WS22216-E1-XL-2RSR
85	150	44	305	325	38 000	1 420	3,4	WS22217-E1-XL-2RSR
90	160	48	345	375	42 500	1 300	4,3	WS22218-E1-XL-2RSR
100	180	55	430	475	52 000	1 140	6,3	WS22220-E1-XL-2RSR
110	180	69	530	750	84 000	830	6,8	24122-BE-XL-2VSR
	200	63	550	600	62 000	1 020	9	WS22222-E1-XL-2RSR
120	180	60	450	690	84 000	860	5,6	24024-BE-XL-2VSR
	200	80	680	950	101 000	740	10,4	24124-BE-XL-2VSR
	215	69	640	740	71 000	920	11,3	WS22224-E1-XL-2RSR
130	200	69	570	860	100 000	780	8,4	24026-BE-XL-2VSR
	210	80	710	1 050	109 000	700	11	24126-BE-XL-2VSR
	230	75	760	890	79 000	840	12,8	WS22226-E1-XL-2RSR
140	210	69	590	930	108 000	740	8,4	24028-BE-XL-2VSR
	225	85	800	1 190	124 000	660	13,8	24128-BE-XL-2VSR

medias ► <https://www.schaeffler.de/std/1EE5>

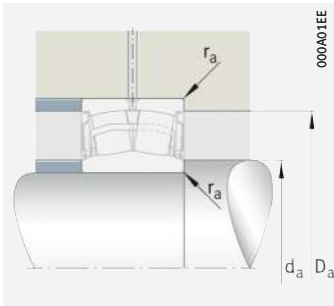

Mounting dimensions

Dimensions						Mounting dimensions			Calculation factors			
d	r	D ₁	d ₂	d _s	n _s	d _a	D _a	r _a	e	Y ₁	Y ₂	Y ₀
	min.	≈	≈			min.	max.	max.				
25	1	46,1	29,8	3,2	4,8	29,8	46,4	1	0,33	2,07	3,09	2,03
30	1	55,5	35	3,2	4,8	35	56,4	1	0,3	2,26	3,37	2,21
35	1,1	64,2	40,1	3,2	4,8	40,1	65	1	0,31	2,21	3,29	2,16
40	1,1	72,6	45,9	3,2	4,8	45,9	73	1	0,27	2,49	3,71	2,43
	1,5	78,1	48,9	3,2	6,5	48,9	81	1,5	0,36	1,86	2,77	1,82
45	1,1	77,8	51,4	3,2	4,8	51,4	78	1	0,25	2,74	4,08	2,68
50	1,1	83,1	56	3,2	4,8	56	83,1	1	0,23	2,95	4,4	2,89
55	1,5	91,9	63,5	3,2	4,8	63,5	91,9	1,5	0,21	3,17	4,72	3,1
	2	104,1	64,8	3,2	6,5	64,8	109	2	0,36	1,89	2,81	1,84
60	1,5	100,7	67,6	3,2	6,5	67,6	101	1,5	0,23	2,98	4,44	2,92
	2,1	110,2	71,4	3,2	6,5	71,4	118	2,1	0,35	1,91	2,85	1,87
65	1,5	110,2	76,2	3,2	6,5	76,2	111	1,5	0,24	2,81	4,19	2,75
70	1,5	113,5	82,5	3,2	6,5	82,5	116	1,5	0,23	2,95	4,4	2,89
	2,1	130,4	80,7	4,8	9,5	80,7	138	2,1	0,34	2	2,98	1,96
75	1,5	120,2	85,6	3,2	6,5	84	121	1,5	0,22	3,1	4,62	3,03
80	2	128,6	91,3	3,2	6,5	91	129	2	0,22	3,14	4,67	3,07
85	2	137,1	96,5	3,2	6,5	96	139	2	0,22	3,04	4,53	2,97
90	2	146,7	101,4	3,2	6,5	101	149	2	0,23	2,9	4,31	2,83
100	2,1	169,1	115	4,8	9,5	112	169,1	2,1	0,24	2,84	4,23	2,78
110	2	167,1	120,8	3,2	6,5	121	169	2	0,34	1,96	2,92	1,92
	2,1	182,6	124,9	4,8	9,5	122	188	2,1	0,25	2,71	4,04	2,65
120	2	170,5	131	3,2	6,5	128,8	171,2	2	0,29	2,33	3,47	2,28
	2	184,5	131,1	3,2	6,5	131	189	2	0,37	1,84	2,74	1,8
	2,1	203,4	136,8	6,3	12,2	132	203,4	2,1	0,25	2,71	4,04	2,65
130	2	187,2	142,1	3,2	6,5	138,8	191,2	2	0,31	2,21	3,29	2,16
	2	196,1	143,1	3,2	6,5	141	199	2	0,34	1,98	2,94	1,93
	3	217,5	146,6	6,3	12,2	144	217,5	2,5	0,26	2,62	3,9	2,56
140	2	198,5	153,3	3,2	6,5	148,8	201,2	2	0,28	2,37	3,53	2,32
	2,1	209,9	153,5	4,8	9,5	152	213	2,1	0,34	1,99	2,96	1,94



Spherical roller bearings

Sealed

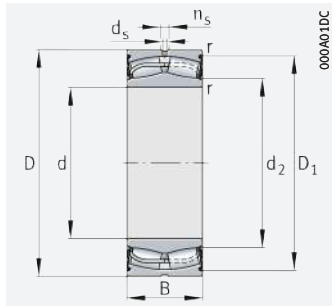

160 mm $D \leq 320 \text{ mm}$
with seal 2VSR

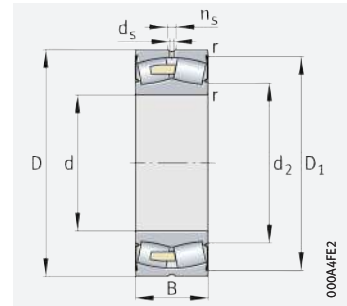

320 mm $D \leq 620 \text{ mm}$
with seal 2RSR

d = 150 – 380 mm

Main dimensions			Basic load ratings		Fatigue limit load	Limiting speed	Mass	Designation
d	D	B	dyn. C_r	stat. C_{0r}	C_{ur}	n_G	m	
			kN	kN	N	min^{-1}	\approx kg	
150	225	75	680	1 090	122 000	690	11,1	24030-BE-XL-2VSR
	250	100	1 050	1 520	148 000	590	20,6	24130-BE-XL-2VSR
160	240	80	770	1 240	137 000	640	12,7	24032-BE-XL-2VSR
	270	109	1 220	1 800	168 000	540	25,4	24132-BE-XL-2VSR
170	260	90	940	1 480	158 000	600	17,2	24034-BE-XL-2VSR
	280	109	1 260	1 900	179 000	530	26,4	24134-BE-XL-2VSR
180	280	100	1 130	1 770	180 000	550	22,7	24036-BE-XL-2VSR
	300	118	1 460	2 170	203 000	500	33,2	24136-BE-XL-2VSR
190	290	100	1 160	1 860	192 000	540	23,7	24038-BE-XL-2VSR
	320	128	1 680	2 550	226 000	460	41,5	24138-BE-XL-2VSR
200	340	112	1 620	2 270	188 000	510	41,5	23140-BE-XL-2RSR
	310	109	1 350	2 150	215 000	500	30,1	24040-BE-XL-2VSR
	340	140	1 880	2 800	250 000	445	49,5	24140-BE-XL-2VSR
220	370	120	1 860	2 700	217 000	465	52,2	23144-BE-XL-2RSR
	370	150	2 190	3 250	290 000	410	64	24144-BE-XL-2VSR
240	400	128	2 140	3 150	249 000	425	64	23148-BE-XL-2RSR
260	440	144	2 600	3 900	290 000	375	90	23152-BE-XL-2RSR
280	460	146	2 750	4 200	315 000	355	96,3	23156-BE-XL-2RSR
300	500	160	3 250	4 950	365 000	325	130	23160-BEA-XL-2RSR-MB1
320	540	176	3 800	5 900	415 000	290	165	23164-BEA-XL-2RSR-MB1
340	580	190	4 400	6 600	470 000	270	210	23168-BEA-XL-2RSR-MB1
360	600	192	4 550	7 100	495 000	260	222	23172-BEA-XL-2RSR-MB1
380	620	194	4 750	7 600	530 000	248	234	23176-BEA-XL-2RSR-MB1

medias ► <https://www.schaeffler.de/std/1EE6>

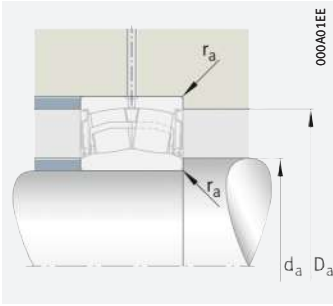

Mounting dimensions

Dimensions						Mounting dimensions			Calculation factors			
d	r	D ₁	d ₂	d _s	n _s	d _a	D _a	r _a	e	Y ₁	Y ₂	Y ₀
	min.	≈	≈			min.	max.	max.				
150	2,1	213,2	164	3,2	6,5	160,2	214,8	2,1	0,29	2,32	3,45	2,26
	2,1	228,9	163,1	4,8	9,5	162	238	2,1	0,37	1,83	2,72	1,79
160	2,1	226,9	174,8	4,8	9,5	170,2	229,8	2,1	0,29	2,32	3,45	2,26
	2,1	245,6	175,5	4,8	9,5	172	258	2,1	0,37	1,8	2,69	1,76
170	2,1	243,3	184,8	4,8	9,5	180,2	249,8	2,1	0,31	2,2	3,27	2,15
	2,1	257,3	186,7	4,8	9,5	182	268	2,1	0,36	1,9	2,83	1,86
180	2,1	259,6	195,6	4,8	9,5	190,2	269,8	2,1	0,32	2,1	3,13	2,06
	3	276,3	196,2	6,3	12,2	194	286	2,5	0,36	1,86	2,77	1,82
190	2,1	271,1	206,2	4,8	9,5	200,2	279,8	2,1	0,31	2,2	3,27	2,15
	3	292,6	208	6,3	12,2	204	306	2,5	0,37	1,82	2,7	1,78
200	3	319	224,6	9,5	17,7	214	326	2,5	0,3	2,25	3,34	2,2
	2,1	287,8	217	6,3	12,2	210,2	299,8	2,1	0,32	2,13	3,17	2,08
	3	309,5	216,2	6,3	12,2	214	326	2,5	0,39	1,71	2,54	1,67
220	4	345	249	9,5	17,7	237	353	3	0,29	2,32	3,45	2,26
	4	338,5	236,2	6,3	12,2	237	353	3	0,39	1,74	2,59	1,7
240	4	374	269	9,5	17,7	257	383	3	0,29	2,35	3,5	2,3
260	4	412	295	9,5	17,7	277	423	3	0,3	2,26	3,37	2,21
280	5	431	315	9,5	17,7	300	440	4	0,28	2,37	3,53	2,32
300	5	460	–	9,5	17,7	320	480	4	0,29	2,3	3,42	2,25
320	5	503	–	12,5	23,5	340	520	4	0,3	2,26	3,37	2,21
340	5	537	–	12,5	23,5	360	560	4	0,3	2,23	3,32	2,18
360	5	560	–	12,5	23,5	380	580	4	0,29	2,3	3,42	2,25
380	5	580	–	12,5	23,5	400	600	4	0,28	2,37	3,53	2,32



Spherical roller bearings

With adapter sleeve

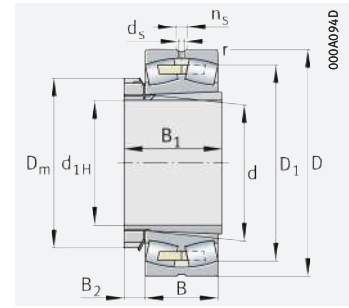
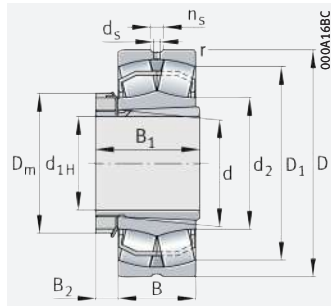

With solid cage, brass or steel

d_{1H} = 20 – 75 mm

Main dimensions				Basic load ratings		Fatigue limit load	Limiting speed	Speed rating	Mass m		Designation	
d _{1H}	d	D	B	dyn. C _r kN	stat. C _{0r} kN	C _{ur} N	n _G min ⁻¹	n _{∅r} min ⁻¹	Bearing ≈ kg	Adapter sleeve ≈ kg	Bearing	Adapter sleeve
20	25	52	18	48,5	42,5	4 800	14 400	9 200	0,175	0,07	22205-E1-XL-K	H305
25	30	62	20	64	57	6 900	12 500	7 800	0,275	0,11	22206-E1-XL-K	H306
30	35	72	23	89	81	9 400	10 700	7 000	0,434	0,153	22207-E1-XL-K	H307
	35	80	21	83	74	8 100	10 900	6 800	0,496	0,153	21307-E1-XL-K-TVPB	H307
35	40	80	23	101	91	11 800	10 500	6 200	0,528	0,192	22208-E1-XL-K	H308
	40	90	23	109	107	14 300	9 800	5 200	0,749	0,192	21308-E1-XL-K	H308
	40	90	33	156	149	13 100	7 600	5 500	1	0,23	22308-E1-XL-K	H2308
40	45	85	23	104	99	12 700	10 100	5 600	0,577	0,253	22209-E1-XL-K	H309
	45	100	25	129	130	17 300	9 000	4 750	0,999	0,253	21309-E1-XL-K	H309
	45	100	36	187	183	16 000	6 800	5 000	1,4	0,298	22309-E1-XL-K	H2309
45	50	90	23	109	107	14 300	9 800	5 100	0,608	0,306	22210-E1-XL-K	H310
	50	110	27	129	130	17 300	9 000	5 400	1,32	0,306	21310-E1-XL-K	H310
	50	110	40	229	223	20 100	6 300	4 800	1,9	0,36	22310-E1-XL-K	H2310
50	55	100	25	129	130	17 300	9 000	4 650	0,825	0,358	22211-E1-XL-K	H311
	55	120	29	160	155	20 200	8 100	5 100	1,28	0,358	21311-E1-XL-K	H311
	55	120	43	265	260	23 900	5 800	4 500	2,2	0,435	22311-E1-XL-K	H2311
55	60	110	28	160	155	20 200	8 100	4 550	1,09	0,401	22212-E1-XL-K	H312
	60	130	31	211	226	28 000	6 700	4 100	1,89	0,401	21312-E1-XL-K	H312
	60	130	46	310	310	28 000	5 400	4 200	2,8	0,493	22312-E1-XL-K	H2312
60	65	120	31	202	210	25 500	7 000	4 200	1,52	0,471	22213-E1-XL-K	H313
	65	140	33	250	270	33 500	6 200	3 600	2,13	0,471	21313-E1-XL-K	H313
	65	140	48	350	365	32 500	5 000	3 800	3,5	0,57	22313-E1-XL-K	H2313
	70	125	31	211	226	28 000	6 700	3 950	1,61	0,74	22214-E1-XL-K	H314
	70	150	35	250	270	33 500	6 200	3 950	3,13	0,74	21314-E1-XL-K	H314
	70	150	51	390	390	36 500	4 800	3 700	4,1	0,92	22314-E1-XL-K	H2314
65	75	130	31	216	237	29 500	6 500	3 700	1,68	0,86	22215-E1-XL-K	H315
	75	160	37	305	325	38 000	5 700	3 750	3,74	0,86	21315-E1-XL-K	H315
	75	160	55	445	450	40 500	4 500	3 550	5,3	1,06	22315-E1-XL-K	H2315
70	80	140	33	250	270	33 500	6 200	3 550	2,08	1,06	22216-E1-XL-K	H316
	80	170	39	305	325	38 000	5 700	4 050	4,54	1,06	21316-E1-XL-K	H316
	80	170	58	495	510	45 000	4 250	3 400	6,1	1,31	22316-E1-XL-K	H2316
75	85	150	36	305	325	38 000	5 700	3 450	2,59	1,21	22217-E1-XL-K	H317
	85	180	41	345	375	42 500	5 200	3 800	5,3	1,21	21317-E1-XL-K	H317
	85	180	60	540	560	49 500	4 100	3 200	7,1	1,47	22317-E1-XL-K	H2317

medias ► <https://www.schaeffler.de/std/1EE7>

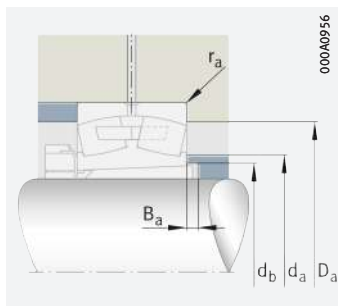

Mounting dimensions

Dimensions									Mounting dimensions					Calculation factors			
d _{1H}	r	D ₁	d ₂	d _s	n _s	D _m	B ₁	B ₂	d _a	D _a	d _b	B _a	r _a	e	Y ₁	Y ₂	Y ₀
	min.	≈	≈					≈	max.	max.	min.	min.	max.				
20	1	44,4	31,5	3,2	4,8	38	29	8,25	30,6	46,4	28	5	1	0,33	2,07	3,09	2,03
25	1	53,7	38,1	3,2	4,8	45	31	8,25	35,6	54,6	33	5	1	0,3	2,26	3,37	2,21
30	1,1	62,5	43,9	3,2	4,8	52	35	9,25	42	65	39	5	1	0,31	2,21	3,29	2,16
	1,5	66,6	47,4	–	–	52	35	9,25	44	71	39	8	1,5	0,26	2,55	3,8	2,5
35	1,1	70,4	48,8	3,2	4,8	58	36	10,25	47	73	44	5	1	0,27	2,49	3,71	2,43
	1,5	80,8	59,9	3,2	4,8	58	36	10,25	49	81	44	5	1,5	0,23	2,95	4,4	2,89
	1,5	76	52,4	3,2	6,5	58	46	10,25	49	81	45	5	1,5	0,36	1,86	2,77	1,82
40	1,1	75,6	55	3,2	4,8	65	39	11,25	52	78	50	8	1	0,25	2,74	4,08	2,68
	1,5	89,8	67,6	3,2	4,8	65	39	11,25	54	91	50	5	1,5	0,21	3,17	4,72	3,1
	1,5	84,7	58,9	3,2	6,5	65	50	11,25	54	91	50	5	1,5	0,36	1,9	2,83	1,86
45	1,1	80,8	59,9	3,2	4,8	70	42	12,25	57	83	55	10	1	0,23	2,95	4,4	2,89
	2	89,8	67,7	3,2	4,8	70	42	12,25	61	99	55	5	2	0,21	3,17	4,72	3,1
	2	92,6	63	3,2	6,5	70	55	12,25	61	99	56	5	2	0,36	1,86	2,77	1,82
50	1,5	89,8	67,6	3,2	4,8	75	45	12,5	64	91	60	10	1,5	0,21	3,17	4,72	3,1
	2	98,3	71,6	3,2	6,5	75	45	12,5	66	109	60	6	2	0,23	2,98	4,44	2,92
	2	101,4	68,9	3,2	6,5	75	59	12,5	66	109	61	6	2	0,36	1,89	2,81	1,84
55	1,5	98,7	71,6	3,2	6,5	80	47	12,5	69	101	65	8	1,5	0,23	2,98	4,44	2,92
	2,1	112,5	84,4	3,2	6,5	80	47	12,5	72	118	65	5	2,1	0,23	2,95	4,4	2,89
	2,1	110,1	74,8	3,2	6,5	80	62	12,5	72	118	66	5	2,1	0,35	1,91	2,85	1,87
60	1,5	107,3	79,1	3,2	6,5	85	50	13,5	74	111	70	8	1,5	0,24	2,81	4,19	2,75
	2,1	126,8	94,9	3,2	6,5	85	50	13,5	77	128	70	5	2,1	0,22	3,14	4,67	3,07
	2,1	119,3	83,2	4,8	9,5	85	65	13,5	77	128	72	5	2,1	0,34	2	2,98	1,96
	1,5	112,5	84,4	3,2	6,5	92	52	13,5	79	116	75	11	1,5	0,23	2,95	4,4	2,89
	2,1	126,2	94,9	3,2	6,5	92	52	13,5	82	138	75	6	2,1	0,22	3,14	4,67	3,07
	2,1	128	86,7	4,8	9,5	92	68	13,5	82	138	77	5	2,1	0,34	2	2,98	1,96
65	1,5	117,7	89,8	3,2	6,5	98	55	14,5	84	121	80	12	1,5	0,22	3,1	4,62	3,03
	2,1	135,2	99,7	3,2	6,5	98	55	14,5	87	148	80	5	2,1	0,22	3,04	4,53	2,97
	2,1	136,3	92,4	4,8	9,5	98	73	14,5	87	148	82	5	2,1	0,34	1,99	2,96	1,94
70	2	126,8	94,9	3,2	6,5	105	59	16,75	91	129	85	12	2	0,22	3,14	4,67	3,07
	2,1	135,4	99,8	3,2	6,5	105	59	16,75	92	158	85	5	2,1	0,22	3,04	4,53	2,97
	2,1	145,1	98,3	4,8	9,5	105	78	16,75	92	158	88	5	2,1	0,34	1,99	2,96	1,94
75	2	135,4	99,7	3,2	6,5	110	63	17,75	96	139	91	12	2	0,22	3,04	4,53	2,97
	3	143,9	106,1	4,8	9,5	110	63	17,75	99	166	91	6	2,5	0,23	2,9	4,31	2,83
	3	154,2	104,4	4,8	9,5	110	82	17,75	99	166	94	6	2,5	0,33	2,04	3,04	2



Spherical roller bearings

With adapter sleeve

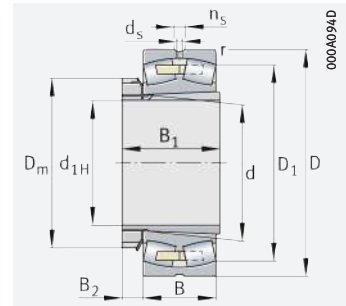
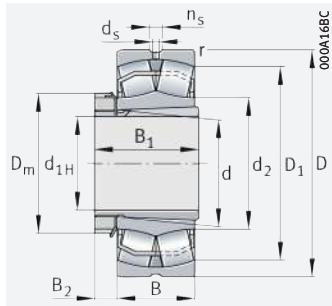

With solid cage, brass or steel

d_{1H} = 80 – 110 mm

Main dimensions				Basic load ratings		Fatigue limit load C _{ur} N	Limiting speed n _G min ⁻¹	Speed rating n _{∅r} min ⁻¹	Mass m		Designation	
d _{1H}	d	D	B	dyn. C _r kN	stat. C _{0r} kN				Bearing ≈ kg	Adapter sleeve ≈ kg	Bearing	Adapter sleeve
80	90	160	40	345	375	42 500	5 200	3 400	3,35	1,41	22218-E1-XL-K	H318
	90	160	52,4	445	520	48 500	4 250	2 650	4,1	1,71	23218-E1-XL-K-TVPB	H2318
	90	160	52,4	445	520	48 500	4 250	2 650	4,3	1,71	23218-E1A-XL-K-M	H2318
	90	190	43	380	415	47 000	4 850	3 600	6,26	1,41	21318-E1-XL-K	H318
	90	190	64	610	630	55 000	3 850	3 000	8,5	1,71	22318-E1-XL-K	H2318
85	95	170	43	380	415	47 000	4 850	3 300	4,04	1,58	22219-E1-XL-K	H319
	95	200	45	425	450	47 500	4 600	3 250	6,63	1,58	21319-E1-XL-K-TVPB	H319
	95	200	67	670	700	59 000	3 700	2 800	9,5	1,95	22319-E1-XL-K	H2319
90	100	165	52	450	570	52 000	4 000	2 750	4,1	1,81	23120-E1-XL-K-TVPB	H3120
	100	165	52	450	570	52 000	4 000	2 750	4,2	1,81	23220-E1A-XL-K-M	H3120
	100	180	46	430	475	52 000	4 550	3 150	4,91	1,76	22220-E1-XL-K	H320
	100	180	60,3	560	660	60 000	3 750	2 410	6,1	2,2	23220-E1-XL-K-TVPB	H2320
	100	180	60,3	560	660	60 000	3 750	2 410	6,3	2,2	23220-E1A-XL-K-M	H2320
	100	215	47	495	530	60 000	4 400	3 050	8,08	1,76	21320-E1-XL-K-TVPB	H320
	100	215	73	810	920	75 000	3 300	2 380	13	2,2	22320-E1-XL-K	H2320
100	110	170	45	400	530	53 000	4 200	3 000	3,4	2,25	23022-E1-XL-K-TVPB	H322
	110	170	45	400	530	53 000	4 200	3 000	3,8	2,25	23022-E1A-XL-K-M	H322
	110	180	56	530	680	60 000	3 700	2 550	4,9	2,32	23122-E1-XL-K-TVPB	H3122
	110	180	56	530	680	60 000	3 700	2 550	5,1	2,32	23122-E1A-XL-K-M	H3122
	110	200	53	550	600	62 000	4 100	3 000	6,99	2,25	22222-E1-XL-K	H322
	110	200	69,8	710	870	71 000	3 250	2 100	8,8	2,78	23222-E1-XL-K-TVPB	H2322
	110	200	69,8	710	870	71 000	3 250	2 100	9,3	2,78	23222-E1A-XL-K-M	H2322
	110	240	50	600	640	69 000	4 000	2 700	10,91	2,25	21322-E1-XL-K-TVPB	H322
	110	240	80	950	1 070	90 000	3 000	2 130	17,4	2,78	22322-E1-XL-K	H2322
110	120	180	46	430	580	58 000	3 950	2 800	3,7	2,01	23024-E1-XL-K-TVPB	H3024
	120	180	46	430	580	58 000	3 950	2 800	4,1	2,01	23024-E1A-XL-K-M	H3024
	120	200	62	630	800	72 000	3 400	2 290	7,1	2,7	23124-E1-XL-K-TVPB	H3124
	120	200	62	630	800	72 000	3 400	2 290	7,6	2,7	23124-E1A-XL-K-M	H3124
	120	215	58	640	740	68 000	3 650	2 700	8,84	2,7	22224-E1-XL-K	H3124
	120	215	76	820	1 020	80 000	3 000	1 910	11,1	3,24	23224-E1-XL-K-TVPB	H2324
	120	215	76	820	1 020	80 000	3 000	1 910	11,4	3,24	23224-E1A-XL-K-M	H2324
	120	260	86	1 080	1 170	102 000	2 850	2 000	22,1	3,24	22324-E1-XL-K	H2324

medias ► <https://www.schaeffler.de/std/1EE8>

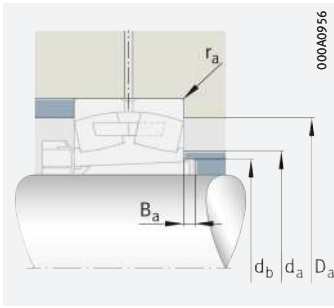

Mounting dimensions

Dimensions									Mounting dimensions					Calculation factors			
d_{1H}	r	D_1	d_2	d_s	n_s	D_m	B_1	B_2	d_a	D_a	d_b	B_a	r_a	e	Y_1	Y_2	Y_0
	min.	≈	≈					≈	max.	max.	min.	min.	max.				
80	2	143,9	106,1	3,2	6,5	120	65	17,75	101	149	96	10	2	0,23	2,9	4,31	2,83
	2	140	104,1	3,2	6,5	120	86	17,75	101	149	100	18	2	0,31	2,2	3,27	2,15
	2	140	-	3,2	6,5	120	86	17,75	101	149	100	18	2	0,31	2,2	3,27	2,15
	3	152,7	112,6	4,8	9,5	120	65	17,75	104	176	96	6	2,5	0,24	2,87	4,27	2,8
	3	162,5	110,2	6,3	12,2	120	86	17,75	104	176	100	6	2,5	0,33	2,03	3,02	1,98
85	2,1	152,7	112,6	4,8	9,5	125	68	18,75	107	158	102	9	2,1	0,24	2,87	4,27	2,8
	3	169,4	124,3	4,8	9,5	125	68	18,75	109	186	102	7	2,5	0,22	3,04	4,53	2,97
	3	171,2	116	6,3	12,2	125	90	18,75	109	186	105	7	2,5	0,33	2,03	3,02	1,98
90	2	146,3	113,9	3,2	6,5	130	76	19,75	111	154	107	7	2	0,28	2,37	3,53	2,32
	2	146,3	-	3,2	6,5	130	76	19,75	111	154	107	7	2	0,28	2,37	3,53	2,32
	2,1	161,4	119	4,8	9,5	130	71	19,75	112	168	108	8	2,1	0,24	2,84	4,23	2,78
	2,1	156,7	116,7	4,8	9,5	130	97	19,75	112	168	110	19	2,1	0,31	2,15	3,2	2,1
	2,1	156,7	-	4,8	9,5	130	97	19,75	112	168	110	19	2,1	0,31	2,15	3,2	2,1
	3	182	132	4,8	9,5	130	71	19,75	114	201	108	7	2,5	0,22	3,14	4,67	3,07
100	3	184,7	130,2	6,3	12,2	130	97	19,75	114	201	110	7	2,5	0,33	2,03	3,02	1,98
	2	154,6	123,7	3,2	6,5	145	77	20,75	118,8	161,2	118	14	2	0,23	2,9	4,31	2,83
	2	154,6	-	3,2	6,5	145	77	20,75	118,8	161,2	118	14	2	0,23	2,9	4,31	2,83
	2	160	124,6	4,8	9,5	145	81	20,75	121	169	117	7	2	0,28	2,39	3,56	2,34
	2	160	-	4,8	9,5	145	81	20,75	121	169	117	7	2	0,28	2,41	3,59	2,35
	2,1	178,7	129,4	4,8	9,5	145	77	20,75	122	188	118	6	2,1	0,25	2,71	4,04	2,65
	2,1	172,7	129,1	4,8	9,5	145	105	20,75	122	188	121	17	2,1	0,33	2,06	3,06	2,01
	2,1	172,7	-	4,8	9,5	145	105	20,75	122	188	121	17	2,1	0,33	2,06	3,06	2,01
	3	202,5	146,4	6,3	12,2	145	77	20,75	124	226	118	9	2,5	0,21	3,24	4,82	3,16
3	204,9	143,1	8	15	145	105	20,75	124	226	121	7	2,5	0,33	2,07	3,09	2,03	
110	2	164,7	133	3,2	6,5	155	72	22	128,8	171,2	127	7	2	0,22	3,04	4,53	2,97
	2	164,7	-	3,2	6,5	155	72	22	128,8	171,2	127	7	2	0,22	3,04	4,53	2,97
	2	177,4	136,2	4,8	9,5	155	88	22	131	189	128	7	2	0,28	2,39	3,56	2,34
	2	177,4	-	4,8	9,5	155	88	22	131	189	128	7	2	0,28	2,39	3,56	2,34
	2,1	192	141,9	6,3	12,2	155	88	22	132	203	128	11	2,1	0,25	2,71	4,04	2,65
	2,1	185,5	139	4,8	9,5	155	112	22	132	203	131	17	2,1	0,33	2,03	3,02	1,98
	2,1	185,5	-	4,8	9,5	155	112	22	132	203	131	17	2,1	0,33	2,03	3,02	1,98
	3	222,4	150,7	8	15	155	112	22	134	246	131	7	2,5	0,33	2,06	3,06	2,01





Spherical roller bearings

With adapter sleeve

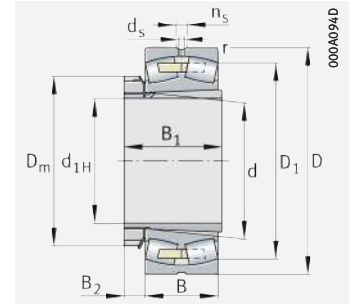
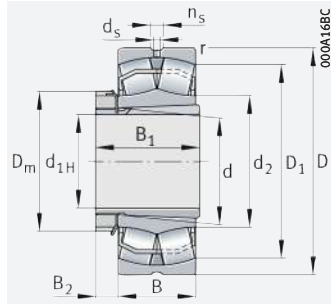

With solid cage, brass or steel

$d_{1H} = 115 - 135 \text{ mm}$

Main dimensions				Basic load ratings		Fatigue limit load C_{ur} N	Limiting speed n_G min^{-1}	Speed rating $n_{\emptyset r}$ min^{-1}	Mass m		Designation	
d_{1H}	d	D	B	dyn. C_r kN	stat. C_{Or} kN				Bearing $\approx \text{kg}$	Adapter sleeve $\approx \text{kg}$	Bearing	Adapter sleeve
115	130	200	52	540	730	69 000	3 600	2 600	5,4	2,96	23026-E1-XL-K-TVPB	H3026
	130	200	52	540	730	69 000	3 600	2 600	5,7	2,96	23026-E1A-XL-K-M	H3026
	130	210	64	680	890	78 000	3 200	2 110	7,8	3,74	23126-E1-XL-K-TVPB	H3126
	130	210	64	680	890	78 000	3 200	2 110	8,1	3,74	23126-E1A-XL-K-M	H3126
	130	230	64	760	890	79 000	3 350	2 500	10,9	3,74	22226-E1-XL-K	H3126
	130	230	80	910	1 150	88 000	2 850	1 740	12,6	4,69	23226-E1-XL-K-TVPB	H2326
	130	230	80	910	1 150	88 000	2 850	1 740	13,6	4,69	23226-E1A-XL-K-M	H2326
	130	280	93	1 250	1 370	116 000	2 650	1 820	27,4	4,69	22326-E1-XL-K	H2326
125	140	210	53	570	800	75 000	3 450	2 390	5,8	3,3	23028-E1-XL-K-TVPB	H3028
	140	210	53	570	800	75 000	3 450	2 390	6	3,3	23028-E1A-XL-K-M	H3028
	140	225	68	760	1 010	87 000	3 000	1 930	9,5	4,46	23128-E1-XL-K-TVPB	H3128
	140	225	68	760	1 010	87 000	3 000	1 930	10,2	4,46	23128-E1A-XL-K-M	H3128
	140	250	68	870	1 040	97 000	3 150	2 250	13,7	4,46	22228-E1-XL-K	H3128
	140	250	88	1 090	1 400	113 000	2 600	1 550	17,1	5,66	23228-E1-XL-K-TVPB	H2328
	140	250	88	1 090	1 400	113 000	2 600	1 550	17,6	5,66	23228-E1A-XL-K-M	H2328
	140	300	102	1 460	1 630	131 000	2 420	1 660	34,4	5,66	22328-E1-XL-K	H2328
135	150	225	56	630	880	85 000	3 250	2 210	7,3	4,02	23030-E1-XL-K-TVPB	H3030
	150	225	56	630	880	85 000	3 250	2 210	7,3	4,02	23030-E1A-XL-K-M	H3030
	150	250	80	1 000	1 330	141 000	2 650	1 720	14,5	5,7	23130-E1-XL-K-TVPB	H3130
	150	250	80	1 000	1 330	141 000	2 650	1 720	15,8	5,7	23130-E1A-XL-K-M	H3130
	150	270	73	1 010	1 210	111 000	2 900	2 050	17,8	5,7	22230-E1-XL-K	H3130
	150	270	96	1 280	1 660	129 000	2 400	1 400	22,3	6,76	23230-E1-XL-K-TVPB	H2330
	150	270	96	1 280	1 660	129 000	2 400	1 400	22,9	6,76	23230-E1A-XL-K-M	H2330
	150	320	108	1 640	1 850	147 000	2 290	1 520	40,9	6,76	22330-E1-XL-K	H2330

medias ► <https://www.schaeffler.de/std/1EE9>

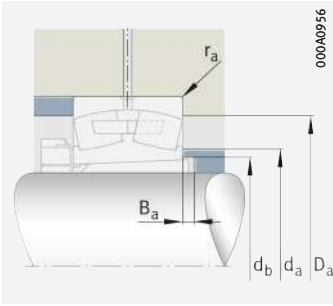

Mounting dimensions

Dimensions									Mounting dimensions					Calculation factors			
d_{1H}	r	D_1	d_2	d_s	n_s	D_m	B_1	B_2	d_a	D_a	d_b	B_a	r_a	e	Y_1	Y_2	Y_0
	min.	≈	≈					≈	max.	max.	min.	min.	max.				
115	2	182,3	145,9	4,8	9,5	165	80	23	138,8	191,2	137	8	2	0,23	2,95	4,4	2,89
	2	182,3	-	4,8	9,5	165	80	23	138,8	191,2	137	8	2	0,23	2,95	4,4	2,89
	2	187,3	146	4,8	9,5	165	92	23	141	199	138	8	2	0,28	2,45	3,64	2,39
	2	187,3	-	4,8	9,5	165	92	23	141	199	138	8	2	0,28	2,45	3,64	2,39
	3	205	151,7	6,3	12,2	165	92	23	144	216	138	8	2,5	0,26	2,62	3,9	2,56
	3	199,3	150	4,8	9,5	165	121	23	144	216	142	21	2,5	0,33	2,07	3,09	2,03
	3	199,3	-	4,8	9,5	165	121	23	144	216	142	21	2,5	0,33	2,07	3,09	2,03
	4	239,5	162,2	9,5	17,7	165	121	23	147	263	142	8	3	0,33	2,06	3,06	2,01
125	2	192,3	155,4	4,8	9,5	180	82	24	148,8	201,2	147	8	2	0,22	3,07	4,57	3
	2	192,3	-	4,8	9,5	180	82	24	148,8	201,2	147	8	2	0,22	3,07	4,57	3
	2,1	201	157,1	4,8	9,5	180	97	24	152	213	149	8	2,1	0,27	2,49	3,71	2,43
	2,1	201	-	4,8	9,5	180	97	24	152	213	149	8	2,1	0,27	2,49	3,71	2,43
	3	223,1	164,9	6,3	12,2	180	97	24	154	236	149	8	2,5	0,25	2,67	3,97	2,61
	3	216	162	6,3	12,2	180	131	24	154	236	152	22	2,5	0,33	2,04	3,04	2
	3	216	-	6,3	12,2	180	131	24	154	236	152	22	2,5	0,33	2,04	3,04	2
	4	255,7	173,5	9,5	17,7	180	131	24	157	283	152	8	3	0,34	2	2,98	1,96
135	2,1	206,3	166,6	4,8	9,5	195	87	26	160,2	214,8	158	8	2,1	0,22	3,1	4,62	3,03
	2,1	206,3	-	4,8	9,5	195	87	26	160,2	214,8	158	8	2,1	0,22	3,1	4,62	3,03
	2,1	220,8	170,1	6,3	12,2	195	111	26	162	238	160	8	2,1	0,29	2,32	3,45	2,26
	2,1	220,8	-	6,3	12,2	195	111	26	162	238	160	8	2,1	0,29	2,32	3,45	2,26
	3	240,8	177,9	8	15	195	111	26	164	256	160	15	2,5	0,25	2,69	4	2,63
	3	232,6	174	6,3	12,2	195	139	26	164	256	163	20	2,5	0,33	2,02	3	1,97
	3	232,6	-	6,3	12,2	195	139	26	164	256	163	20	2,5	0,33	2,02	3	1,97
	4	273,2	185,3	9,5	17,7	195	139	26	167	303	163	8	3	0,33	2,02	3	1,97



Spherical roller bearings

With adapter sleeve

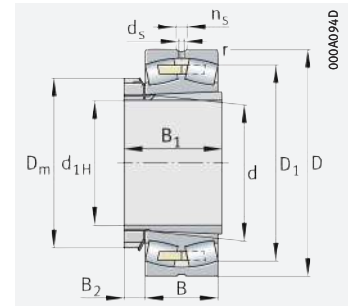
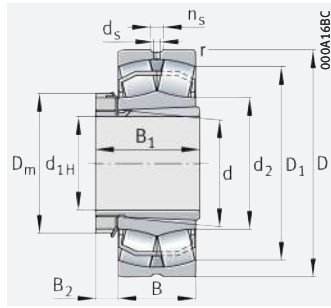

With solid cage, brass or steel

$d_{1H} = 140 - 170 \text{ mm}$

Main dimensions				Basic load ratings		Fatigue limit load C_{ur} N	Limiting speed n_G min^{-1}	Speed rating $n_{\partial r}$ min^{-1}	Mass m		Designation	
d_{1H}	d	D	B	dyn. C_r kN	stat. C_{Or} kN				Bearing $\approx \text{kg}$	Adapter sleeve $\approx \text{kg}$	Bearing	Adapter sleeve
140	160	240	60	720	1010	95 000	3 050	2 060	8,7	5,44	23032-E1-XL-K-TVPB	H3032
	160	240	60	720	1010	95 000	3 050	2 060	9,4	5,44	23032-E1A-XL-K-M	H3032
	160	270	86	1 160	1 550	162 000	2 490	1 560	18,5	7,81	23132-E1-XL-K-TVPB	H3132
	160	270	86	1 160	1 550	162 000	2 490	1 560	18,6	7,81	23132-E1A-XL-K-M	H3132
	160	290	80	1 150	1 400	125 000	2 650	1 900	22,4	7,81	22232-E1-XL-K	H3132
	160	290	104	1 460	1 910	146 000	2 210	1 280	27,7	9,32	23232-E1-XL-K-TVPB	H2332
	160	290	104	1 460	1 910	146 000	2 210	1 280	28,5	9,32	23232-E1A-XL-K-M	H2332
	160	340	114	1 680	1 990	157 000	2 250	1 420	47,3	9,32	22332-BE-XL-K	H2332
150	170	260	67	880	1 230	148 000	2 800	1 890	11,9	6,25	23034-E1-XL-K-TVPB	H3034
	170	260	67	880	1 230	148 000	2 800	1 890	12,5	6,25	23034-E1A-XL-K-M	H3034
	170	280	88	1 220	1 690	173 000	2 380	1 460	19,9	8,6	23134-E1-XL-K-TVPB	H3134
	170	280	88	1 220	1 690	173 000	2 380	1 460	19,5	8,6	23134-E1A-XL-K-M	H3134
	170	310	86	1 320	1 570	140 000	2 550	1 780	27,1	8,6	22234-E1-XL-K	H3134
	170	310	110	1 640	2 170	163 000	2 090	1 160	33,1	10,4	23234-E1-XL-K-TVPB	H2334
	170	310	110	1 640	2 170	163 000	2 090	1 160	34,6	10,4	23234-E1A-XL-K-M	H2334
	170	360	120	1 870	2 220	173 000	2 130	1 320	56,9	10,4	22334-BE-XL-K	H2334
160	180	250	52	445	840	57 000	3 200	1 850	7,8	6,01	23936-S-K-MB	H3936
	180	280	74	1 040	1 450	169 000	2 600	1 760	15,6	7,18	23036-E1-XL-K-TVPB	H3036
	180	280	74	1 040	1 450	169 000	2 600	1 760	16	7,18	23036-E1A-XL-K-M	H3036
	180	300	96	1 420	1 950	194 000	2 230	1 350	25,9	9,8	23136-E1-XL-K-TVPB	H3136
	180	300	96	1 420	1 950	194 000	2 230	1 350	25,5	9,8	23136-E1A-XL-K-M	H3136
	180	320	86	1 360	1 680	148 000	2 470	1 670	28,5	9,8	22236-E1-XL-K	H3136
	180	320	112	1 720	2 340	173 000	2 010	1 090	36	11,6	23236-E1-XL-K-TVPB	H2336
	180	320	112	1 720	2 340	173 000	2 010	1 090	37	11,6	23236-E1A-XL-K-M	H2336
	180	380	126	2 060	2 460	190 000	2 030	1 230	66,6	11,6	22336-BE-XL-K	H2336
170	190	290	75	1 080	1 550	179 000	2 490	1 660	16,3	7,8	23038-E1-XL-K-TVPB	H3038
	190	290	75	1 080	1 550	179 000	2 490	1 660	17,7	7,8	23038-E1A-XL-K-M	H3038
	190	320	104	1 610	2 220	216 000	2 070	1 260	30,3	7,8	23138-E1-XL-K-TVPB	H3138
	190	320	104	1 610	2 220	216 000	2 070	1 260	32,4	7,8	23138-E1A-XL-K-M	H3138
	190	340	92	1 360	1 760	159 000	2 480	1 620	36	7,8	22238-BE-XL-K	H3138
	190	340	120	1 740	2 400	200 000	1 990	1 070	42,6	12,9	23238-BE-XL-K	H2338
	190	400	132	2 220	2 650	207 000	1 940	1 160	77,2	12,9	22338-BE-XL-K	H2338

medias ► <https://www.schaeffler.de/std/1EEA>

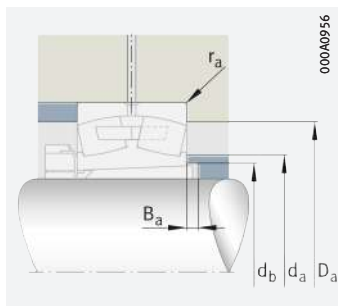

Mounting dimensions

Dimensions									Mounting dimensions					Calculation factors			
d_{1H}	r	D_1	d_2	d_s	n_s	D_m	B_1	B_2	d_a	D_a	d_b	B_a	r_a	e	Y_1	Y_2	Y_0
	min.	≈	≈					≈	max.	max.	min.	min.	max.				
140	2,1	219,9	177	6,3	12,2	210	93	27,5	170,2	229,8	168	8	2,1	0,22	3,1	4,62	3,03
	2,1	219,9	-	6,3	12,2	210	93	27,5	170,2	229,8	168	8	2,1	0,22	3,1	4,62	3,03
	2,1	238,3	183,2	8	15	210	119	27,5	172	258	170	8	2,1	0,29	2,32	3,45	2,26
	2,1	238,3	-	8	15	210	119	27,5	172	258	170	8	2,1	0,29	2,32	3,45	2,26
	3	258,2	190,9	8	15	210	119	27,5	174	276	170	14	2,5	0,26	2,64	3,93	2,58
	3	249,3	186,7	8	15	210	147	27,5	174	276	174	18	2,5	0,34	2	2,98	1,96
	3	249,3	-	8	15	210	147	27,5	174	276	174	18	2,5	0,34	2	2,98	1,96
	4	286,7	201,2	9,5	17,7	210	147	27,5	177	323	174	8	3	0,35	1,94	2,88	1,89
150	2,1	237,2	189,8	6,3	12,2	220	101	28,5	180,2	249,8	179	8	2,1	0,23	2,98	4,44	2,92
	2,1	237,2	-	6,3	12,2	220	101	28,5	180,2	249,8	179	8	2,1	0,23	2,98	4,44	2,92
	2,1	248,1	193,4	8	15	220	122	28,5	182	268	180	8	2,1	0,28	2,37	3,53	2,32
	2,1	248,1	-	8	15	220	122	28,5	182	268	180	8	2,1	0,28	2,37	3,53	2,32
	4	275,4	199,8	9,5	17,7	220	122	28,5	187	293	180	10	3	0,26	2,6	3,87	2,54
	4	267,4	199,8	8	15	220	154	28,5	187	293	185	18	3	0,33	2,03	3,02	1,98
	4	267,4	-	8	15	220	154	28,5	187	293	185	18	3	0,33	2,03	3,02	1,98
	4	303,9	213,1	9,5	17,7	220	154	28,5	187	343	185	8	3	0,35	1,95	2,9	1,91
160	2	230,9	-	4,8	9,5	230	87	29,5	188,8	241,2	188	8	2	0,2	3,42	5,09	3,34
	2,1	254,3	201,8	8	15	230	109	29,5	190,2	269,8	189	8	2,1	0,23	2,9	4,31	2,83
	2,1	254,3	-	8	15	230	109	29,5	190,2	269,8	189	8	2,1	0,23	2,9	4,31	2,83
	3	264,8	204,1	8	15	230	131	29,5	194	286	191	8	2,5	0,29	2,32	3,45	2,26
	3	264,8	-	8	15	230	131	29,5	194	286	180	8	2,5	0,29	2,32	3,45	2,26
	4	285,9	211,3	9,5	17,7	230	131	29,5	197	303	191	18	3	0,25	2,71	4,04	2,65
	4	277,3	210,6	8	15	230	161	29,5	197	303	195	22	3	0,33	2,07	3,09	2,03
	4	277,3	-	8	15	230	161	29,5	197	303	195	22	3	0,33	2,07	3,09	2,03
	4	320,8	224,9	12,5	23,5	230	161	29,5	197	363	195	8	3	0,34	1,96	2,92	1,92
	170	2,1	264,5	211,9	8	15	240	112	30,5	200,2	279,8	199	9	2,1	0,23	2,98	4,44
2,1		264,5	-	8	15	240	112	30,5	200,2	279,8	199	9	2,1	0,23	2,98	4,44	2,92
3		281,6	217	8	15	240	112	30,5	204	306	202	9	2,5	0,3	2,28	3,39	2,23
3		281,6	-	8	15	240	112	30,5	204	306	202	9	2,5	0,3	2,28	3,39	2,23
4		295,2	225,2	9,5	17,7	240	112	30,5	207	323	202	21	3	0,26	2,6	3,87	2,54
4		289	222,4	9,5	17,7	240	169	30,5	207	323	206	21	3	0,34	1,98	2,94	1,93
5		338,1	236,8	12,5	23,5	240	169	30,5	210	380	206	9	4	0,34	1,96	2,92	1,92



Spherical roller bearings

With adapter sleeve

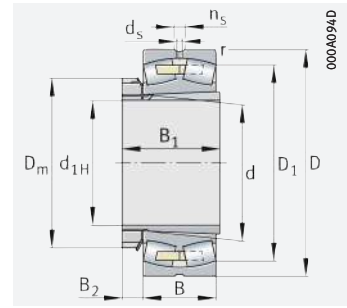
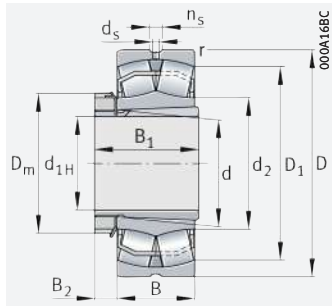

With solid cage, brass or steel

d_{1H} = 180 – 260 mm

Main dimensions				Basic load ratings		Fatigue limit load	Limiting speed	Speed rating	Mass m		Designation	
d _{1H}	d	D	B	dyn. C _r kN	stat. C _{0r} kN	C _{ur} N	n _G min ⁻¹	n _{thr} min ⁻¹	Bearing ≈ kg	Adapter sleeve ≈ kg	Bearing	Adapter sleeve
180	200	280	60	550	1070	71 000	2 800	1 650	11,5	8,2	23940-S-K-MB	H3940
	200	310	82	1 270	1 800	202 000	2 330	1 550	20,8	9,5	23040-E1-XL-K-TVPB	H3040
	200	310	82	1 270	1 800	202 000	2 330	1 550	21,4	9,5	23040-E1A-XL-K-M	H3040
	200	340	112	1 610	2 270	188 000	2 040	1 230	40,9	12,5	23140-BE-XL-K	H3140
	200	360	98	1 520	1 990	175 000	2 330	1 510	42,3	12,5	22240-BE-XL-K	H3140
	200	360	128	1 940	2 700	219 000	1 870	1 000	57,3	14,2	23240-BE-XL-K	H2340
	200	420	138	2 440	2 950	225 000	1 830	1 080	87,4	14,2	22340-BE-XL-K	H2340
200	220	300	60	610	1 240	72 000	2 600	1 460	12,3	8,45	23944-S-K-MB	H3944
	220	340	90	1 260	1 900	177 000	2 230	1 450	28,5	10,5	23044-BE-XL-K	H3044X
	220	370	120	1 860	2 700	217 000	1 860	1 080	50,5	16	23144-BE-XL-K	H3144X
	220	400	108	1 840	2 360	210 000	2 140	1 350	58,3	16	22244-BE-XL-K	H3144X
	220	400	144	2 380	3 300	265 000	1 700	880	75,3	17,8	23244-BE-XL-K	H2344X
220	240	320	60	640	1 370	93 000	2 440	1 310	13,4	11,3	23948-K-MB	H3948
	240	360	92	1 350	2 120	194 000	2 080	1 310	31,6	13,7	23048-BE-XL-K	H3048
	240	400	128	2 130	3 150	248 000	1 700	970	62	18,7	23148-BE-XL-K	H3148X
	240	440	120	2 230	2 900	247 000	1 900	1 200	81,8	18,7	22248-BE-XL-K	H3148X
	240	440	160	2 850	4 000	310 000	1 500	770	102	20,9	23248-BE-XL-K	H2348X
240	240	500	155	3 200	4 050	305 000	1 510	830	148	20,9	22348-BEA-XL-K-MB1	H2348X
	260	360	75	940	1 940	108 000	2 100	1 190	22,4	13,6	23952-K-MB	H3952
	260	400	104	1 670	2 600	233 000	1 850	1 170	45,9	16	23052-BE-XL-K	H3052X
	260	440	144	2 600	3 900	305 000	1 500	860	87,2	23,6	23152-BE-XL-K	H3152X
	260	480	130	2 600	3 450	290 000	1 720	1 070	104	23,6	22252-BEA-XL-K-MB1	H3152X
260	260	480	174	3 350	4 750	360 000	1 360	690	134	25,8	23252-BEA-XL-K-MB1	H2352X
	260	540	165	3 650	4 650	350 000	1 390	740	179	25,8	22352-BEA-XL-K-MB1	H2352X
	280	380	75	970	2 040	129 000	2 000	1 100	24,7	15,6	23956-K-MB	H3956
	280	420	106	1 780	2 850	255 000	1 740	1 090	49,3	18,5	23056-BE-XL-K	H3056
	280	460	146	2 750	4 200	315 000	1 420	790	93,1	26,3	23156-BE-XL-K	H3156X
280	500	130	2 750	3 700	310 000	1 650	990	109	26,3	22256-BEA-XL-K-MB1	H3156X	
280	500	176	3 550	5 200	385 000	1 280	630	143,7	29,8	23256-BEA-XL-K-MB1	H2356X	
280	580	175	4 150	5 300	395 000	1 280	670	223	29,8	22356-BEA-XL-K-MB1	H2356X	

medias ► <https://www.schaeffler.de/std/1EEB>

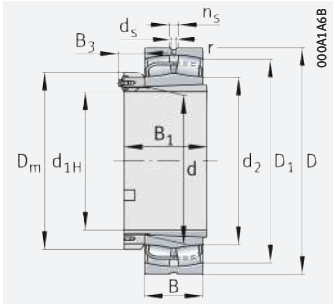

With locknut and retaining bracket

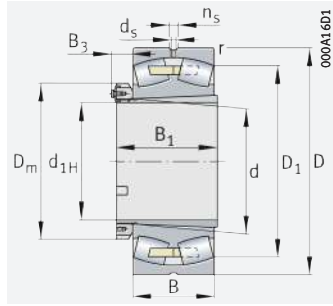

With solid cage, brass or steel;
with locknut and retaining bracket

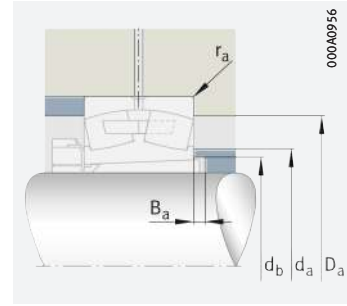

Mounting dimensions

Dimensions										Mounting dimensions					Calculation factors			
d_{1H}	r	D_1	d_2	d_s	n_s	D_m	B_1	B_2	B_3	d_a	D_a	d_b	B_a	r_a	e	Y_1	Y_2	Y_0
	min.	≈	≈					≈	≈	max.	max.	min.	min.	max.				
180	2,1	256,9	–	6,3	12,2	250	98	31,5	–	210,2	269,8	210	9	2,1	0,2	3,42	5,09	3,34
	2,1	281,6	223,4	8	15	250	120	31,5	–	210,2	299,8	210	10	2,1	0,23	2,9	4,31	2,83
	2,1	281,6	–	8	15	250	120	31,5	–	210,2	299,8	210	10	2,1	0,23	2,9	4,31	2,83
	3	295,8	230,4	9,5	17,7	250	150	31,5	–	214	326	212	10	2,5	0,32	2,1	3,13	2,06
	4	310,9	238,2	9,5	17,7	250	150	31,5	–	217	343	212	24	3	0,26	2,57	3,83	2,52
	4	305,3	235	9,5	17,7	250	176	31,5	–	217	343	216	20	3	0,35	1,95	2,9	1,91
	5	355,1	248,8	12,5	23,5	250	176	31,5	–	220	400	216	10	4	0,34	1,98	2,94	1,93
200	2,1	277,4	–	6,3	12,2	260	96	–	39	230,2	289,8	230	9	2,1	0,18	3,76	5,59	3,67
	3	304,5	248,8	8	15	260	126	–	39	232,4	327,6	231	12	2,5	0,24	2,81	4,19	2,75
	4	323	254,8	9,5	17,7	260	161	35	–	237	353	233	10	3	0,31	2,15	3,2	2,1
	4	346,6	260,1	9,5	17,7	260	161	35	–	237	383	233	22	3	0,26	2,57	3,83	2,52
	4	338	255,8	9,5	17,7	260	186	35	–	237	383	236	11	3	0,36	1,9	2,83	1,86
	5	391,1	273,4	12,5	23,5	260	186	35	–	240	440	236	10	4	0,33	2,06	3,06	2,01
220	2,1	297,8	–	6,3	12,2	290	101	–	45	250,2	309,8	250	11	2,1	0,17	4,05	6,04	3,96
	3	324,6	269,5	8	15	290	133	–	45	252,4	347,6	251	11	2,5	0,23	2,98	4,44	2,92
	4	349,9	275,9	9,5	17,7	290	172	37	–	257	383	254	11	3	0,31	2,18	3,24	2,13
	4	380,4	285,6	12,5	23,5	290	172	37	–	257	423	254	19	3	0,26	2,55	3,8	2,5
	4	370,8	280,8	12,5	23,5	290	199	37	–	257	423	257	6	3	0,36	1,87	2,79	1,83
	5	426,4	–	12,5	23,5	290	199	37	–	260	480	257	11	4	0,32	2,12	3,15	2,07
240	2,1	330,5	–	8	15	310	116	–	45	270,2	349,8	270	11	2,1	0,19	3,54	5,27	3,46
	4	358,7	295,5	9,5	17,7	310	145	–	45	274,6	385,4	272	13	3	0,23	2,9	4,31	2,83
	4	382,7	301,7	9,5	17,7	310	190	38	–	277	423	276	11	3	0,32	2,12	3,15	2,07
	5	415,1	–	12,5	23,5	310	190	38	–	280	460	276	25	4	0,26	2,57	3,83	2,52
	5	404,3	–	12,5	23,5	310	211	38	–	280	460	278	2	4	0,36	1,87	2,79	1,83
	6	460,6	–	12,5	23,5	310	211	38	–	286	514	278	11	5	0,31	2,15	3,2	2,1
260	2,1	350	–	8	15	330	121	–	49	290,2	369,8	290	12	2,1	0,18	3,76	5,59	3,67
	4	379,2	314,3	9,5	17,7	330	152	–	49	294,6	405,4	292	12	3	0,22	3,01	4,48	2,94
	5	403,4	321,4	9,5	17,7	330	195	39	–	300	440	296	12	4	0,31	2,21	3,29	2,16
	5	436	–	12,5	23,5	330	195	39	–	300	480	296	28	4	0,25	2,71	4,04	2,65
	5	425,4	–	12,5	23,5	330	224	39	–	300	480	299	11	4	0,34	1,96	2,92	1,92
	6	495,5	–	12,5	23,5	330	224	39	–	306	554	299	12	5	0,31	2,18	3,24	2,13



Spherical roller bearings

With adapter sleeve

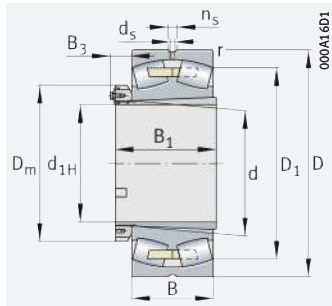

With solid cage, brass or steel;
with locknut and retaining bracket

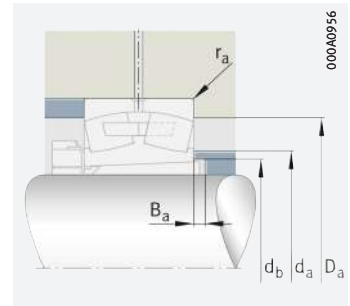

Mounting dimensions

d_{1H} = 280 – 410 mm

Main dimensions				Basic load ratings		Fatigue limit load	Limiting speed	Speed rating	Mass m		Designation	
d _{1H}	d	D	B	dyn. C _r kN	stat. C _{0r} kN	C _{ur} N	n _G min ⁻¹	n _{∅r} min ⁻¹	Bearing ≈ kg	Adapter sleeve ≈ kg	Bearing	Adapter sleeve
280	300	420	90	1 270	2 650	165 000	1 780	1 000	39,1	20,9	23960-B-K-MB	H3960
	300	460	118	2 160	3 450	295 000	1 570	980	68,4	23,7	23060-BE-XL-K	H3060
	300	500	160	3 250	4 950	365 000	1 300	720	126	31,1	23160-BEA-XL-K-MB1	H3160
	300	540	140	3 100	4 250	355 000	1 500	900	139	31,1	22260-BEA-XL-K-MB1	H3160
	300	540	192	4 100	6 100	440 000	1 160	560	187	35,1	23260-BEA-XL-K-MB1	H3260
300	320	440	90	1 310	2 750	201 000	1 700	930	41	22,1	23964-K-MB	H3964-HG
	320	480	121	2 300	3 750	320 000	1 480	920	75,6	25,7	23064-BEA-XL-K-MB1	H3064-HG
	320	540	176	3 800	5 900	415 000	1 170	650	161	36,2	23164-BEA-XL-K-MB1	H3164-HG
	320	580	150	3 550	4 700	395 000	1 410	830	171	36,2	22264-BEA-XL-K-MB1	H3164-HG
	320	580	208	4 650	7 000	495 000	1 060	510	229,6	40,6	23264-BEA-XL-K-MB1	H3264-HG
320	340	520	133	2 700	4 400	365 000	1 360	840	101	30	23068-BEA-XL-K-MB1	H3068-HG
	340	580	190	4 350	6 600	465 000	1 090	600	204	51,8	23168-BEA-XL-K-MB1	H3168-HG
	340	620	224	5 300	7 900	570 000	1 000	475	292	57,2	23268-BEA-XL-K-MB1	H3268-HG
340	360	480	90	1 440	3 200	210 000	1 540	800	45	25,9	23972-K-MB	H3972-HG
	360	540	134	2 800	4 650	390 000	1 300	790	104	31,6	23072-BEA-XL-K-MB1	H3072-HG
	360	600	192	4 550	7 100	495 000	1 040	560	215	54,3	23172-BEA-XL-K-MB1	H3172-HG
	360	650	232	5 700	8 900	610 000	930	430	330,5	63,8	23272-BEA-XL-K-MB1	H3272-HG
360	380	520	106	1 780	4 000	265 000	1 340	750	66,3	32,1	23976-K-MB	H3976-HG
	380	560	135	2 900	5 000	410 000	1 230	740	109	36,2	23076-BEA-XL-K-MB1	H3076-HG
	380	620	194	4 700	7 600	530 000	990	530	227	64,1	23176-BEA-XL-K-MB1	H3176-HG
	380	680	240	6 200	9 600	660 000	890	400	374	72,4	23276-BEA-XL-K-MB1	H3276-HG
380	400	540	106	1 830	4 150	270 000	1 290	710	68,2	35,4	23980-B-K-MB	H3980-HG
	400	600	148	3 400	5 700	465 000	1 150	690	144	41,7	23080-BEA-XL-K-MB1	H3080-HG
	400	650	200	5 000	8 100	570 000	950	495	246	71,3	23180-BEA-XL-K-MB1	H3180-HG
	400	720	256	7 000	10 900	730 000	820	370	450	83,7	23280-BEA-XL-K-MB1	H3280-HG
400	420	560	106	1 910	4 450	300 000	1 230	660	72,1	38,6	23984-K-MB	H3984-HG
	420	620	150	3 650	6 300	510 000	1 090	650	153	45,7	23084-BEA-XL-K-MB1	H3084-HG
	420	700	224	6 000	9 600	650 000	860	455	342	88,4	23184-BEA-XL-K-MB1	H3184-HG
	420	760	272	7 800	12 300	800 000	770	340	537	98,7	23284-BEA-XL-K-MB1	H3284-HG
410	440	600	118	2 230	5 200	295 000	1 130	620	98,3	59	23988-K-MB	H3988-HG
	440	650	157	3 950	6 900	550 000	1 030	610	176	67,7	23088-BEA-XL-K-MB1	H3088-HG
	440	720	226	6 200	10 200	680 000	820	430	358	108	23188-BEA-XL-K-MB1	H3188-HG
	440	790	280	8 300	13 200	860 000	730	320	592	123	23288-BEA-XL-K-MB1	H3288-HG

medias ▶ <https://www.schaeffler.de/std/1EEC>

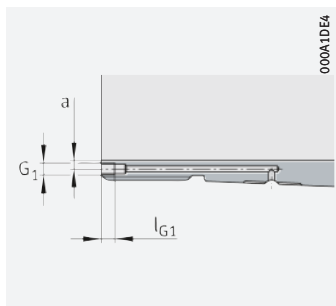

Hydraulic adapter sleeve (...HG)
Mounting dimensions

Dimensions										Mounting dimensions								Calculation factors			
d_{1H}	r	D_1	d_2	d_s	n_s	D_m	B_1	B_3	d_a	D_a	d_b	B_a	r_a	G_1	a	l_{G1}	e	Y_1	Y_2	Y_0	
		min.	≈	≈			≈	max.		max.	min.	min.	max.								
280	3	384,6	–	9,5	17,7	360	140	53	312,4	407,6	311	12	2,5	–	–	–	0,2	3,42	5,09	3,34	
	4	413	340	9,5	17,7	360	168	53	314,6	445,4	313	12	3	–	–	–	0,23	2,92	4,35	2,86	
	5	436,8	–	9,5	17,7	360	208	52	320	480	318	12	4	–	–	–	0,31	2,18	3,24	2,13	
	5	470,5	–	12,5	23,5	360	208	52	320	520	318	32	4	–	–	–	0,25	2,71	4,04	2,65	
	5	458	–	12,5	23,5	360	240	52	320	520	321	12	4	–	–	–	0,35	1,92	2,86	1,88	
300	3	406,2	–	9,5	17,7	380	140	54	332,4	427,6	332	12	2,5	M6	3,5	7	0,19	3,62	5,39	3,54	
	4	433	–	9,5	17,7	380	171	54	334,6	465,4	334	13	3	M6	3,5	7	0,22	3,01	4,48	2,94	
	5	469,3	–	12,5	23,5	380	226	55	340	520	338	13	4	M6	3,5	7	0,32	2,13	3,17	2,08	
	5	505,1	–	12,5	23,5	380	226	55	340	560	338	39	4	M6	3,5	7	0,25	2,71	4,04	2,65	
	5	490,4	–	12,5	23,5	380	258	55	340	560	343	13	4	M6	3,5	7	0,35	1,91	2,85	1,87	
320	5	467,1	–	12,5	23,5	320	187	57	358	502	355	14	4	M6	3,5	7	0,23	2,92	4,35	2,86	
	5	502,6	–	12,5	23,5	320	254	70	360	560	360	14	4	M6	3,5	7	0,32	2,1	3,13	2,06	
	6	523,5	–	12,5	23,5	320	288	70	366	594	364	14	5	M6	3,5	7	0,36	1,85	2,76	1,81	
340	3	447,1	–	9,5	17,7	420	144	57	372,4	467,6	372	14	2,5	M6	3,5	7	0,17	4,05	6,04	3,96	
	5	487,6	–	12,5	23,5	420	188	57	378	522	375	14	4	M6	3,5	7	0,22	3,04	4,53	2,97	
	5	523,3	–	12,5	23,5	420	259	73	380	580	380	14	4	M6	3,5	7	0,31	2,18	3,24	2,13	
	6	550,8	–	12,5	23,5	420	299	73	386	624	385	14	5	M6	3,5	7	0,36	1,9	2,83	1,86	
360	4	477,6	–	9,5	17,7	450	164	61	394,6	505,4	393	15	3	M6	3,5	7	0,19	3,58	5,33	3,5	
	5	508,1	–	12,5	23,5	450	193	61	398	542	396	15	4	M6	3,5	7	0,21	3,17	4,72	3,1	
	5	543,6	–	12,5	23,5	450	264	75	400	600	401	15	4	M6	3,5	7	0,3	2,25	3,34	2,2	
	6	578,1	–	12,5	23,5	450	310	75	406	654	405	15	5	M6	3,5	7	0,35	1,92	2,86	1,88	
380	4	499	–	9,5	17,7	470	168	65	414,6	525,4	413	15	3	M6	3,5	7	0,18	3,71	5,52	3,63	
	5	541,9	–	12,5	23,5	470	210	65	418	582	417	15	4	M6	3,5	7	0,22	3,07	4,57	3	
	6	571,4	–	12,5	23,5	470	272	80	426	624	421	15	5	M6	3,5	7	0,29	2,3	3,42	2,25	
	6	610,9	–	12,5	23,5	470	328	80	426	694	427	15	5	M6	3,5	7	0,36	1,9	2,83	1,86	
400	4	519,5	–	9,5	17,7	490	168	65	434,6	545,4	433	15	3	M6	3,5	7	0,18	3,85	5,73	3,76	
	5	560,7	–	12,5	23,5	490	212	65	438	602	437	16	4	M6	3,5	7	0,21	3,17	4,72	3,1	
	6	609,8	–	12,5	23,5	490	304	88	446	674	443	16	5	M6	3,5	7	0,31	2,18	3,24	2,13	
	7,5	643,4	–	12,5	23,5	490	352	88	452	728	449	16	6	M6	3,5	7	0,36	1,89	2,81	1,84	
410	4	552,8	–	12,5	23,5	520	189	75	454,6	585,4	454	17	3	M8	6,5	12	0,18	3,66	5,46	3,58	
	6	589,3	–	12,5	23,5	520	228	75	463	627	458	17	5	M8	6,5	12	0,21	3,17	4,72	3,1	
	6	630,2	–	12,5	23,5	520	307	88	466	694	463	17	5	M8	6,5	12	0,3	2,25	3,34	2,2	
	7,5	670,7	–	12,5	23,5	520	361	88	472	758	469	17	6	M8	6,5	12	0,35	1,91	2,85	1,87	



Spherical roller bearings

With adapter sleeve

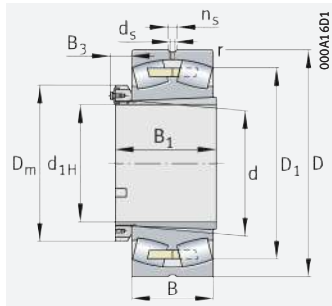

With solid cage, brass or steel;
with locknut and retaining bracket

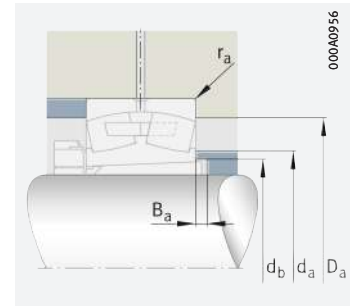

Mounting dimensions

$d_{1H} = 430 - 850 \text{ mm}$

Main dimensions				Basic load ratings		Fatigue limit load C_{ur} N	Limiting speed n_G min^{-1}	Speed rating $n_{\theta r}$ min^{-1}	Mass m		Designation ▶681 1.12 ▶683 1.13 X-life ▶671	Bearing	Adapter sleeve
d_{1H}	d	D	B	dyn. C_r kN	stat. C_{0r} kN				Bearing $\approx \text{kg}$	Adapter sleeve $\approx \text{kg}$			
430	460	620	118	2 270	5 400	370 000	1080	590	103	62,4	23992-B-K-MB	H3992-HG	
	460	680	163	4 300	7 500	590 000	980	580	201	71,8	23092-BEA-XL-K-MB1	H3092-HG	
	460	760	240	6 900	11 500	740 000	770	395	431	118	23192-BEA-XL-K-MB1	H3192-HG	
	460	830	296	9 200	14 700	930 000	690	295	695	138,9	23292-BEA-XL-K-MB1	H3292-HG	
450	480	650	128	2 550	6 000	460 000	1040	570	121	66,8	23996-B-K-MB	H3996-HG	
	480	700	165	4 450	8 000	620 000	950	550	210	76,8	23096-BEA-XL-K-MB1	H3096-HG	
	480	790	248	7 400	12 400	790 000	740	375	479	135	23196-BEA-XL-K-MB1	H3196-HG	
	480	870	310	10 000	16 200	1 010 000	650	275	804	159,2	23296-BEA-XL-K-MB1	H3296-HG	
470	500	670	128	2 600	6 300	400 000	990	540	124	76,1	239/500-K-MB	H39/500-HG	
	500	720	167	4 700	8 700	750 000	890	510	223	85,2	230/500-BEA-XL-K-MB1	H30/500-HG	
	500	830	264	8 300	13 900	860 000	690	350	574	149,9	231/500-BEA-XL-K-MB1	H31/500-HG	
500	530	710	136	2 850	6 900	385 000	930	500	146	91,6	239/530-K-MB	H39/530-HG	
	530	780	185	5 600	10 100	860 000	820	475	302	103	230/530-BEA-XL-K-MB1	H30/530-HG	
	530	870	272	8 900	15 000	940 000	660	325	634	161	231/530-BEA-XL-K-MB1	H31/530-HG	
530	560	750	140	3 100	7 600	520 000	880	465	176	98,5	239/560-B-K-MB	H39/560-HG	
	560	820	195	6 100	11 200	930 000	760	440	350	112	230/560-BEA-XL-K-MB1	H30/560-HG	
	560	920	280	9 700	16 400	1 030 000	630	300	731	184	231/560-BEA-XL-K-MB1	H31/560-HG	
560	600	800	150	3 450	8 600	630 000	810	430	210	132,2	239/600-B-K-MB	H39/600-HG	
	600	870	200	6 600	12 300	1 020 000	710	405	398	152,3	230/600-BEA-XL-K-MB1	H30/600-HG	
	600	980	300	9 000	19 200	810 000	560	270	901	241,8	231/600-K-MB	H31/600-HG	
600	630	850	165	4 100	9 900	710 000	740	405	283	126,3	239/630-B-K-MB	H39/630-HG	
	630	920	212	7 400	13 700	1 120 000	670	380	476	143,1	230/630-BEA-XL-K-MB1	H30/630-HG	
630	670	900	170	4 300	10 600	750 000	710	375	310	166	239/670-B-K-MB	H39/670-HG	
	670	980	230	7 200	15 800	1 100 000	630	350	590	194	230/670-B-K-MB	H30/670-HG	
670	710	950	180	4 800	12 100	720 000	670	350	336	206	239/710-K-MB	H39/710-HG	
	710	1030	236	7 600	16 900	1 150 000	590	325	650	234,2	230/710-B-K-MB	H30/710-HG	
710	750	1000	185	5 200	13 000	790 000	640	325	394	219,6	239/750-K-MB	H39/750-HG	
	750	1090	250	8 500	19 100	1 010 000	550	305	786	248	230/750-K-MB	H30/750-HG	
750	800	1060	195	5 900	15 100	1 010 000	580	295	490	268,9	239/800-B-K-MB	H39/800-HG	
	800	1150	258	9 300	21 200	1 420 000	530	280	877	311,6	230/800-K-MB	H30/800-HG	
800	850	1 120	200	6 300	16 400	960 000	550	275	554	298,5	239/850-K-MB	H39/850-HG	
850	900	1 180	206	6 500	17 200	1 010 000	520	260	641	335	239/900-K-MB	H39/900-HG	

medias ▶ <https://www.schaeffler.de/std/1EED>

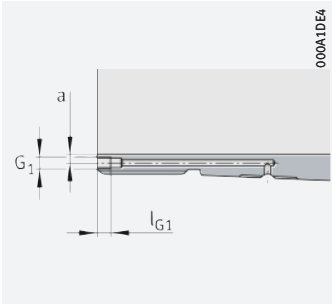

Hydraulic adapter sleeve (...HG)
Mounting dimensions

Dimensions									Mounting dimensions								Calculation factors			
d_{1H}	r	D_1	d_s	n_s	D_m	B_1	B_3		d_a	D_a	d_b	B_a	r_a	G_1	a	l_{G1}	e	Y_1	Y_2	Y_0
	min.	≈					≈		max.	max.	min.	min.	max.							
430	4	573,3	12,5	23,5	540	189	75		474,6	605,4	474	17	3	M8	6,5	12	0,18	3,85	5,73	3,76
	6	616,7	12,5	23,5	540	234	75		483	657	478	17	5	M8	6,5	12	0,21	3,17	4,72	3,1
	7,5	663,4	12,5	23,5	540	326	93		492	728	484	17	6	M8	6,5	12	0,31	2,21	3,29	2,16
	7,5	703,5	12,5	23,5	540	382	93		492	798	490	17	6	M8	6,5	12	0,36	1,9	2,83	1,86
450	5	598,8	12,5	23,5	560	200	75		498	632	496	18	4	M8	6,5	12	0,18	3,76	5,59	3,67
	6	636,9	12,5	23,5	560	237	75		503	677	499	18	5	M8	6,5	12	0,21	3,27	4,87	3,2
	7,5	690,4	12,5	23,5	560	335	93		512	758	505	18	6	M8	6,5	12	0,3	2,23	3,32	2,18
	7,5	737,1	12,5	23,5	560	397	93		512	838	512	18	6	M8	6,5	12	0,36	1,9	2,83	1,86
470	5	619,3	12,5	23,5	580	208	83		518	652	516	18	4	M8	6,5	12	0,17	3,9	5,81	3,81
	6	657,1	12,5	23,5	580	247	83		523	697	519	18	5	M8	6,5	12	0,21	3,24	4,82	3,16
	7,5	723,1	12,5	23,5	580	356	98		532	798	527	18	6	M8	6,5	12	0,31	2,2	3,27	2,15
500	5	656,5	12,5	23,5	630	216	88		548	692	546	18	4	M8	6	12	0,18	3,85	5,73	3,76
	6	708,2	12,5	23,5	630	265	88		553	757	550	18	5	M8	6	12	0,22	3,1	4,62	3,03
	7,5	760,5	12,5	23,5	630	364	102		562	838	558	18	6	M8	6	12	0,3	2,25	3,34	2,2
530	5	693,4	12,5	23,5	650	227	95		578	732	577	18	4	M8	6	12	0,17	3,95	5,88	3,86
	6	745	12,5	23,5	650	282	95		583	797	581	18	5	M8	6	12	0,22	3,1	4,62	3,03
	7,5	806,6	12,5	23,5	650	377	107		592	888	589	18	6	M8	6	12	0,29	2,32	3,45	2,26
560	5	740,5	12,5	23,5	700	239	95		618	782	618	20	4	G ¹ / ₈	8	12	0,17	3,95	5,88	3,86
	6	793,3	12,5	23,5	700	289	95		623	847	622	20	5	G ¹ / ₈	8	12	0,21	3,24	4,82	3,16
	7,5	852,6	12,5	23,5	700	399	108		632	948	629	20	6	G ¹ / ₈	8	12	0,31	2,2	3,27	2,15
600	6	784,5	12,5	23,5	730	254	95		653	827	649	20	5	M8	6	12	0,18	3,8	5,66	3,72
	7,5	837,8	12,5	23,5	730	301	95		658	892	653	20	6	M8	6	12	0,21	3,24	4,82	3,16
630	6	831,5	12,5	23,5	780	264	101		693	877	689	20	5	G ¹ / ₈	8	12	0,17	3,95	5,88	3,86
	7,5	888,7	12,5	23,5	780	324	101		698	952	694	20	6	G ¹ / ₈	8	12	0,22	3,01	4,48	2,94
670	6	877,5	12,5	23,5	830	286	110		733	927	730	22	5	G ¹ / ₈	8	12	0,18	3,85	5,73	3,76
	7,5	938,8	12,5	23,5	830	342	110		738	1002	735	23	6	G ¹ / ₈	8	12	0,22	3,07	4,57	3
710	6	923,2	12,5	23,5	870	291	110		773	977	771	23	5	G ¹ / ₈	8	12	0,17	3,95	5,88	3,86
	7,5	990,9	12,5	23,5	870	356	110		778	1062	776	23	6	G ¹ / ₈	8	12	0,22	3,01	4,48	2,94
750	6	983,7	12,5	23,5	920	303	110		823	1037	822	25	5	G ¹ / ₈	10	12	0,17	4,05	6,04	3,96
	7,5	1050,9	12,5	23,5	920	366	110		828	1122	828	25	6	G ¹ / ₈	10	12	0,22	3,07	4,57	3
800	6	1039,9	12,5	23,5	980	308	113		873	1097	873	25	5	G ¹ / ₈	10	12	0,16	4,11	6,12	4,02
850	6	1098,8	12,5	23,5	1030	326	122		923	1157	923	27	5	G ¹ / ₈	10	12	0,16	4,28	6,37	4,19



Spherical roller bearings

With withdrawal sleeve

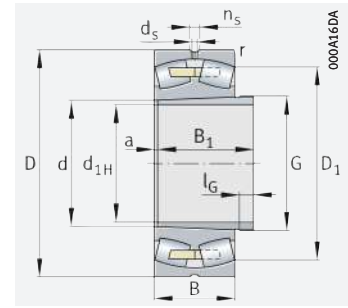
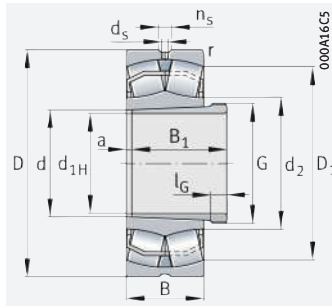

With solid cage, brass or steel

d_{1H} = 35 – 75 mm

Main dimensions				Basic load ratings		Fatigue limit load	Limiting speed	Speed rating	Mass m		Designation	
d _{1H}	d	D	B	dyn. C _r	stat. C _{0r}				C _{ur}	n _G	n _{∅r}	Bearing
				kN	kN	N	min ⁻¹	min ⁻¹	≈ kg	≈ kg		
35	40	80	23	101	91	11 800	10 500	6 200	0,528	0,09	22208-E1-XL-K	AH308
	40	90	23	109	107	14 300	9 800	5 200	0,749	0,09	21308-E1-XL-K	AH308
	40	90	33	156	149	13 100	7 600	5 500	1	0,13	22308-E1-XL-K	AH2308
40	45	85	23	104	99	12 700	10 100	5 600	0,577	0,11	22209-E1-XL-K	AH309
	45	100	25	129	130	17 300	9 000	4 750	0,999	0,11	21309-E1-XL-K	AH309
	45	100	36	187	183	16 000	6 800	5 000	1,4	0,17	22309-E1-XL-K	AH2309
45	50	90	23	109	107	14 300	9 800	5 100	0,608	0,14	22210-E1-XL-K	AHX310
	50	110	27	129	130	17 300	9 000	5 400	1,32	0,14	21310-E1-XL-K	AHX310
	50	110	40	229	223	20 100	6 300	4 800	1,9	0,22	22310-E1-XL-K	AHX2310
50	55	100	25	129	130	17 300	9 000	4 650	0,825	0,17	22211-E1-XL-K	AHX311
	55	120	29	160	155	20 200	8 100	5 100	1,28	0,17	21311-E1-XL-K	AHX311
	55	120	43	265	260	23 900	5 800	4 500	2,2	0,26	22311-E1-XL-K	AHX2311
55	60	110	28	160	155	20 200	8 100	4 550	1,09	0,2	22212-E1-XL-K	AHX312
	60	130	31	211	226	28 000	6 700	4 100	1,89	0,2	21312-E1-XL-K	AHX312
	60	130	46	310	310	28 000	5 400	4 200	2,8	0,32	22312-E1-XL-K	AHX2312
60	65	120	31	202	210	25 500	7 000	4 200	1,52	0,23	22213-E1-XL-K	AH313G
	65	140	33	250	270	33 500	6 200	3 600	2,13	0,23	21313-E1-XL-K	AH313G
	65	140	48	350	365	32 500	5 000	3 800	3,5	0,36	22313-E1-XL-K	AH2313G
65	70	125	31	211	226	28 000	6 700	3 950	1,61	0,26	22214-E1-XL-K	AH314G
	70	150	35	250	270	33 500	6 200	3 950	3,13	0,26	21314-E1-XL-K	AH314G
	70	150	51	390	390	36 500	4 800	3 700	4,1	0,42	22314-E1-XL-K	AHX2314G
70	75	130	31	216	237	29 500	6 500	3 700	1,68	0,29	22215-E1-XL-K	AH315G
	75	160	37	305	325	38 000	5 700	3 750	3,74	0,29	21315-E1-XL-K	AH315G
	75	160	55	445	450	40 500	4 500	3 550	5,3	0,48	22315-E1-XL-K	AHX2315G
75	80	140	33	250	270	33 500	6 200	3 550	2,08	0,38	22216-E1-XL-K	AH316
	80	170	39	305	325	38 000	5 700	4 050	4,54	0,38	21316-E1-XL-K	AH316
	80	170	58	495	510	45 000	4 250	3 400	6,1	0,61	22316-E1-XL-K	AHX2316

medias ► <https://www.schaeffler.de/std/1EEF>

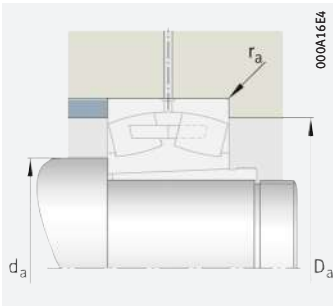

Mounting dimensions

Dimensions											Mounting dimensions			Calculation factors			
d _{1H}	r	D ₁	d ₂	d _s	n _s	a	l _G	Thread G	B ₁	d _a	D _a	r _a	e	Y ₁	Y ₂	Y ₀	
	min.	≈	≈			≈				min.	max.	max.					
35	1,1	70,4	48,8	3,2	4,8	3	6	M45×1,5	29	47	73	1	0,27	2,49	3,71	2,43	
	1,5	80,8	59,9	3,2	4,8	3	6	M45×1,5	29	49	81	1,5	0,23	2,95	4,4	2,89	
	1,5	76	52,4	3,2	6,5	3	7	M45×1,5	40	49	81	1,5	0,36	1,86	2,77	1,82	
40	1,1	75,6	55	3,2	4,8	3	6	M50×1,5	31	52	78	1	0,25	2,74	4,08	2,68	
	1,5	89,8	67,6	3,2	4,8	3	6	M50×1,5	31	54	91	1,5	0,21	3,17	4,72	3,1	
	1,5	84,7	58,9	3,2	6,5	3	7	M50×1,5	44	54	91	1,5	0,36	1,9	2,83	1,86	
45	1,1	80,8	59,9	3,2	4,8	3	7	M55×2	35	57	83	1	0,23	2,95	4,4	2,89	
	2	89,8	67,7	3,2	4,8	3	7	M55×2	35	61	99	2	0,21	3,17	4,72	3,1	
	2	92,6	63	3,2	6,5	3	9	M55×2	50	61	99	2	0,36	1,86	2,77	1,82	
50	1,5	89,8	67,6	3,2	4,8	3	7	M60×2	37	64	91	1,5	0,21	3,17	4,72	3,1	
	2	98,3	71,6	3,2	6,5	3	7	M60×2	37	66	109	2	0,23	2,98	4,44	2,92	
	2	101,4	68,9	3,2	6,5	3	10	M60×2	54	66	109	2	0,36	1,89	2,81	1,84	
55	1,5	98,7	71,6	3,2	6,5	3	8	M65×2	40	69	101	1,5	0,23	2,98	4,44	2,92	
	2,1	112,5	84,4	3,2	6,5	3	8	M65×2	40	72	118	2,1	0,23	2,95	4,4	2,89	
	2,1	110,1	74,8	3,2	6,5	3	11	M65×2	58	72	118	2,1	0,35	1,91	2,85	1,87	
60	1,5	107,3	79,1	3,2	6,5	3	8	M70×2	42	74	111	1,5	0,24	2,81	4,19	2,75	
	2,1	126,8	94,9	3,2	6,5	3	8	M70×2	42	77	128	2,1	0,22	3,14	4,67	3,07	
	2,1	119,3	83,2	4,8	9,5	3	12	M70×2	61	77	128	2,1	0,34	2	2,98	1,96	
65	1,5	112,5	84,4	3,2	6,5	4	8	M75×2	43	79	116	1,5	0,23	2,95	4,4	2,89	
	2,1	126,2	94,9	3,2	6,5	4	8	M75×2	43	82	138	2,1	0,22	3,14	4,67	3,07	
	2,1	128	86,7	4,8	9,5	4	12	M75×2	64	82	138	2,1	0,34	2	2,98	1,96	
70	1,5	117,7	89,8	3,2	6,5	4	8	M80×2	45	84	121	1,5	0,22	3,1	4,62	3,03	
	2,1	135,2	99,7	3,2	6,5	4	8	M80×2	45	87	148	2,1	0,22	3,04	4,53	2,97	
	2,1	136,3	92,4	4,8	9,5	4	12	M80×2	68	87	148	2,1	0,34	1,99	2,96	1,94	
75	2	126,8	94,9	3,2	6,5	4	8	M90×2	48	91	129	2	0,22	3,14	4,67	3,07	
	2,1	135,4	99,8	3,2	6,5	4	8	M90×2	48	92	158	2,1	0,22	3,04	4,53	2,97	
	2,1	145,1	98,3	4,8	9,5	4	12	M90×2	71	92	158	2,1	0,34	1,99	2,96	1,94	



Spherical roller bearings

With withdrawal sleeve

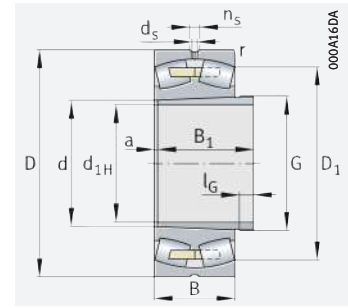
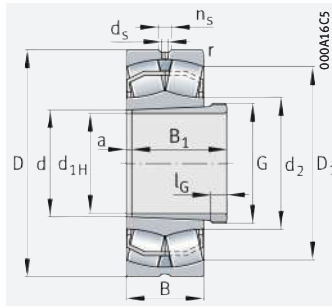

With solid cage, brass or steel

d_{1H} = 80 – 105 mm

Main dimensions				Basic load ratings		Fatigue limit load C _{ur}	Limiting speed n _G	Speed rating n _{Dr}	Mass m		Designation	
d _{1H}	d	D	B	dyn. C _r	stat. C _{0r}				Bearing	With- drawal sleeve	Bearing	With- drawal sleeve
				kN	kN	N	min ⁻¹	min ⁻¹	≈ kg	≈ kg		
80	85	150	36	305	325	38 000	5 700	3 450	2,59	0,44	22217-E1-XL-K	AHX317
	85	180	41	345	375	42 500	5 200	3 800	5,3	0,44	21317-E1-XL-K	AHX317
	85	180	60	540	560	49 500	4 100	3 200	7,1	0,68	22317-E1-XL-K	AHX2317
85	90	160	40	345	375	42 500	5 200	3 400	3,35	0,48	22218-E1-XL-K	AHX318
	90	160	52,4	445	520	48 500	4 250	2 650	4,1	0,58	23218-E1-XL-K-TVPB	AHX3218
	90	160	52,4	445	520	48 500	4 250	2 650	4,3	0,58	23218-E1A-XL-K-M	AHX3218
	90	190	43	380	415	47 000	4 850	3 600	6,26	0,48	21318-E1-XL-K	AHX318
	90	190	64	610	630	55 000	3 850	3 000	8,5	0,78	22318-E1-XL-K	AHX2318
90	95	170	43	380	415	47 000	4 850	3 300	4,04	0,55	22219-E1-XL-K	AHX319
	95	200	45	425	450	47 500	4 600	3 250	6,63	0,55	21319-E1-XL-K-TVPB	AHX319
	95	200	67	670	700	59 000	3 700	2 800	9,5	0,91	22319-E1-XL-K	AHX2319
95	100	165	52	450	570	52 000	4 000	2 750	4,1	0,67	23120-E1-XL-K-TVPB	AHX3120
	100	165	52	450	570	52 000	4 000	2 750	4,2	0,67	23120-E1A-XL-K-M	AHX3120
	100	180	46	430	475	52 000	4 550	3 150	4,91	0,6	22220-E1-XL-K	AHX320
	100	180	60,3	560	660	60 000	3 750	2 410	6,1	0,78	23220-E1-XL-K-TVPB	AHX3220
	100	180	60,3	560	660	60 000	3 750	2 410	6,3	0,78	23220-E1A-XL-K-M	AHX3220
	100	215	47	495	530	60 000	4 400	3 050	8,08	0,6	21320-E1-XL-K-TVPB	AHX320
	100	215	73	810	920	75 000	3 300	2 380	13	1,03	22320-E1-XL-K	AHX2320
	105	110	170	45	400	530	53 000	4 200	3 000	3,4	0,73	23022-E1-XL-K-TVPB
110	170	45	400	530	53 000	4 200	3 000	3,8	0,73	23022-E1A-XL-K-M	AHX322	
110	180	56	530	680	60 000	3 700	2 550	4,9	0,79	23122-E1-XL-K-TVPB	AHX3122	
110	180	56	530	680	60 000	3 700	2 550	5,1	0,79	23122-E1A-XL-K-M	AHX3122	
110	180	69	530	750	84 000	3 350	1 960	6,7	0,73	24122-BE-XL-K30	AH24122	
110	200	53	550	600	62 000	4 100	3 000	6,99	0,79	22222-E1-XL-K	AHX3122	
110	200	69,8	710	870	71 000	3 250	2 100	8,8	0,98	23222-E1-XL-K-TVPB	AHX3222A	
110	200	69,8	710	870	71 000	3 250	2 100	9,3	0,98	23222-E1A-XL-K-M	AHX3222A	
110	240	50	600	640	69 000	4 000	2 700	10,91	0,73	21322-E1-XL-K-TVPB	AHX322	
110	240	80	950	1 070	90 000	3 000	2 130	17,4	1,26	22322-E1-XL-K	AHX2322G	

medias ► <https://www.schaeffler.de/std/1EEF>

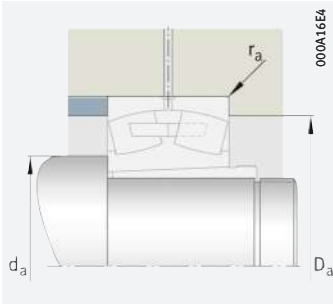

Mounting dimensions

Dimensions											Mounting dimensions			Calculation factors			
d_{1H}	r	D_1	d_2	d_s	n_s	a	l_G	Thread G	B_1	d_a	D_a	r_a	e	Y_1	Y_2	Y_0	
	min.	≈	≈			≈				min.	max.	max.					
80	2	135,4	99,7	3,2	6,5	4	9	M95×2	52	96	139	2	0,22	3,04	4,53	2,97	
	3	143,9	106,1	4,8	9,5	4	9	M95×2	52	99	166	2,5	0,23	2,9	4,31	2,83	
	3	154,2	104,4	4,8	9,5	4	13	M95×2	74	99	166	2,5	0,33	2,04	3,04	2	
85	2	143,9	106,1	3,2	6,5	4	9	M100×2	53	101	149	2	0,23	2,9	4,31	2,83	
	2	140	104,1	3,2	6,5	4	10	M100×2	63	101	149	2	0,31	2,2	3,27	2,15	
	2	140	-	3,2	6,5	4	10	M100×2	63	101	149	2	0,31	2,2	3,27	2,15	
	3	152,7	112,6	4,8	9,5	4	9	M100×2	53	104	176	2,5	0,24	2,87	4,27	2,8	
	3	162,5	110,2	6,3	12,2	4	14	M100×2	79	104	176	2,5	0,33	2,03	3,02	1,98	
90	2,1	152,7	112,6	4,8	9,5	4	10	M105×2	57	107	158	2,1	0,24	2,87	4,27	2,8	
	3	169,4	124,3	4,8	9,5	4	10	M105×2	57	109	186	2,5	0,22	3,04	4,53	2,97	
	3	171,2	116	6,3	12,2	4	16	M105×2	85	109	186	2,5	0,33	2,03	3,02	1,98	
95	2	146,3	113,9	3,2	6,5	4	11	M110×2	64	111	154	2	0,28	2,37	3,53	2,32	
	2	146,3	-	3,2	6,5	4	11	M110×2	64	111	154	2	0,28	2,37	3,53	2,32	
	2,1	161,4	119	4,8	9,5	4	10	M110×2	59	112	168	2,1	0,24	2,84	4,23	2,78	
	2,1	156,7	116,7	4,8	9,5	4	11	M110×2	73	112	168	2,1	0,31	2,15	3,2	2,1	
	2,1	156,7	-	4,8	9,5	4	11	M110×2	73	112	168	2,1	0,31	2,15	3,2	2,1	
	3	182	132	4,8	9,5	4	10	M110×2	59	114	201	2,5	0,22	3,14	4,67	3,07	
	3	184,7	130,2	6,3	12,2	4	16	M110×2	90	114	201	2,5	0,33	2,03	3,02	1,98	
105	2	154,6	123,7	3,2	6,5	4	12	M120×2	63	118,8	161,2	2	0,23	2,9	4,31	2,83	
	2	154,6	-	3,2	6,5	4	12	M120×2	63	118,8	161,2	2	0,23	2,9	4,31	2,83	
	2	160	124,6	4,8	9,5	4	11	M120×2	68	121	169	2	0,28	2,39	3,56	2,34	
	2	160	-	4,8	9,5	4	11	M120×2	68	121	169	2	0,28	2,41	3,59	2,35	
	2	154,9	125,6	3,2	6,5	9	13	M115×2	82	121	169	2	0,34	1,96	2,92	1,92	
	2,1	178,7	129,4	4,8	9,5	4	11	M120×2	68	122	188	2,1	0,25	2,71	4,04	2,65	
	2,1	172,7	129,1	4,8	9,5	4	11	M120×2	82	122	188	2,1	0,33	2,06	3,06	2,01	
	2,1	172,7	-	4,8	9,5	4	11	M120×2	82	122	188	2,1	0,33	2,06	3,06	2,01	
	3	202,5	146,4	6,3	12,2	4	12	M120×2	63	124	226	2,5	0,21	3,24	4,82	3,16	
	3	204,9	143,1	8	15	4	16	M120×2	98	124	226	2,5	0,33	2,07	3,09	2,03	



Spherical roller bearings

With withdrawal sleeve

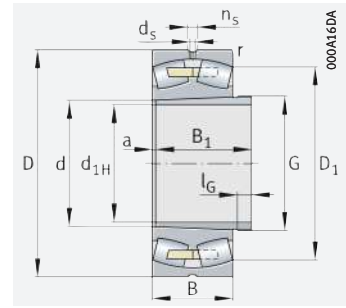
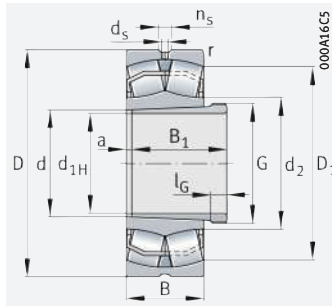

With solid cage, brass or steel

d_{1H} = 115 – 135 mm

Main dimensions				Basic load ratings		Fatigue limit load C _{ur}	Limiting speed n _G	Speed rating n _{gr}	Mass m		Designation ▶681 1.12 ▶683 1.13 X-life ▶671	Bearing	With- drawal sleeve
d _{1H}	d	D	B	dyn. C _r	stat. C _{0r}				Bearing	With- drawal sleeve			
				kN	kN	N	min ⁻¹	min ⁻¹	≈ kg	≈ kg			
115	120	180	46	430	580	58 000	3 950	2 800	3,7	0,77	23024-E1-XL-K-TVPB	AHX3024	
	120	180	46	430	580	58 000	3 950	2 800	4,1	0,77	23024-E1A-XL-K-M	AHX3024	
	120	180	60	450	690	84 000	3 450	2 360	5,4	0,71	24024-BE-XL-K30	AH24024	
	120	200	62	630	800	72 000	3 400	2 290	7,1	0,97	23124-E1-XL-K-TVPB	AHX3124	
	120	200	62	630	800	72 000	3 400	2 290	7,6	0,97	23124-E1A-XL-K-M	AHX3124	
	120	200	80	680	950	101 000	2 950	1 740	10,2	1,02	24124-BE-XL-K30	AH24124	
	120	215	58	640	740	68 000	3 650	2 700	8,84	0,97	22224-E1-XL-K	AHX3124	
	120	215	76	820	1 020	80 000	3 000	1 910	11,1	1,22	23224-E1-XL-K-TVPB	AHX3224A	
	120	215	76	820	1 020	80 000	3 000	1 910	11,4	1,22	23224-E1A-XL-K-M	AHX3224A	
	120	260	86	1 080	1 170	102 000	2 850	2 000	22,1	1,5	22324-E1-XL-K	AHX2324G	
125	130	200	52	540	730	69 000	3 600	2 600	5,4	0,94	23026-E1-XL-K-TVPB	AHX3026	
	130	200	52	540	730	69 000	3 600	2 600	5,7	0,94	23026-E1A-XL-K-M	AHX3026	
	130	200	69	570	860	100 000	3 100	2 130	8,1	0,89	24026-BE-XL-K30	AH24026	
	130	210	64	680	890	78 000	3 200	2 110	7,8	1,1	23126-E1-XL-K-TVPB	AHX3126	
	130	210	64	680	890	78 000	3 200	2 110	8,1	1,1	23126-E1A-XL-K-M	AHX3126	
	130	210	80	710	1 050	109 000	2 800	1 560	10,8	1,13	24126-BE-XL-K30	AH24126	
	130	230	64	760	890	79 000	3 350	2 500	10,9	1,1	22226-E1-XL-K	AHX3126	
	130	230	80	910	1 150	88 000	2 850	1 740	12,6	1,48	23226-E1-XL-K-TVPB	AHX3226G	
	130	230	80	910	1 150	88 000	2 850	1 740	13,6	1,48	23226-E1A-XL-K-M	AHX3226G	
	130	280	93	1 250	1 370	116 000	2 650	1 820	27,4	1,84	22326-E1-XL-K	AHX2326G	
135	140	210	53	570	800	75 000	3 450	2 390	5,8	1,03	23028-E1-XL-K-TVPB	AHX3028	
	140	210	53	570	800	75 000	3 450	2 390	6	1,03	23028-E1A-XL-K-M	AHX3028	
	140	210	69	590	930	108 000	2 950	1 950	8,1	0,96	24028-BE-XL-K30	AH24028	
	140	225	68	760	1 010	87 000	3 000	1 930	9,5	1,29	23128-E1-XL-K-TVPB	AHX3128	
	140	225	68	760	1 010	87 000	3 000	1 930	10,2	1,29	23128-E1A-XL-K-M	AHX3128	
	140	225	85	800	1 190	124 000	2 650	1 430	13,5	1,29	24128-BE-XL-K30	AH24128	
	140	250	68	870	1 040	97 000	3 150	2 250	13,7	1,29	22228-E1-XL-K	AHX3128	
	140	250	88	1 090	1 400	113 000	2 600	1 550	17,1	1,72	23228-E1-XL-K-TVPB	AHX3228G	
	140	250	88	1 090	1 400	113 000	2 600	1 550	17,6	1,72	23228-E1A-XL-K-M	AHX3228G	
	140	300	102	1 460	1 630	131 000	2 420	1 660	34,4	2,21	22328-E1-XL-K	AHX2328G	

medias ▶ <https://www.schaeffler.de/std/1EF0>

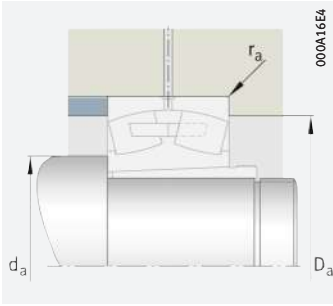

Mounting dimensions

Dimensions										Mounting dimensions			Calculation factors			
d_{1H}	r	D_1	d_2	d_s	n_s	a	l_G	Thread G	B_1	d_a	D_a	r_a	e	Y_1	Y_2	Y_0
	min.	≈	≈			≈				min.	max.	max.				
115	2	164,7	133	3,2	6,5	4	13	M130×2	60	128,8	171,2	2	0,22	3,04	4,53	2,97
	2	164,7	-	3,2	6,5	4	13	M130×2	60	128,8	171,2	2	0,22	3,04	4,53	2,97
	2	159,8	134,5	3,2	6,5	9	13	M125×2	73	128,8	171,2	2	0,29	2,33	3,47	2,28
	2	177,4	136,2	4,8	9,5	4	12	M130×2	75	131	189	2	0,28	2,39	3,56	2,34
	2	177,4	-	4,8	9,5	4	12	M130×2	75	131	189	2	0,28	2,39	3,56	2,34
	2	170,3	136,6	3,2	6,5	9	13	M130×2	93	131	189	2	0,37	1,84	2,74	1,8
	2,1	192	141,9	6,3	12,2	4	12	M130×2	75	132	203	2,1	0,25	2,71	4,04	2,65
	2,1	185,5	139	4,8	9,5	4	13	M130×2	90	132	203	2,1	0,33	2,03	3,02	1,98
	2,1	185,5	-	4,8	9,5	4	13	M130×2	90	132	203	2,1	0,33	2,03	3,02	1,98
	3	222,4	150,7	8	15	4	17	M130×2	105	134	246	2,5	0,33	2,06	3,06	2,01
125	2	182,3	145,9	4,8	9,5	4	14	M140×2	67	138,8	191,2	2	0,23	2,95	4,4	2,89
	2	182,3	-	4,8	9,5	4	14	M140×2	67	138,8	191,2	2	0,23	2,95	4,4	2,89
	2	176,1	146,2	3,2	6,5	10	14	M135×2	83	138,8	191,2	2	0,31	2,21	3,29	2,16
	2	187,3	146	4,8	9,5	4	12	M140×2	78	141	199	2	0,28	2,45	3,64	2,39
	2	187,3	-	4,8	9,5	4	12	M140×2	78	141	199	2	0,28	2,45	3,64	2,39
	2	181,2	148,3	3,2	6,5	10	14	M140×2	94	141	199	2	0,34	1,98	2,94	1,93
	3	205	151,7	6,3	12,2	4	12	M140×2	78	144	216	2,5	0,26	2,62	3,9	2,56
	3	199,3	150	4,8	9,5	4	15	M140×2	98	144	216	2,5	0,33	2,07	3,09	2,03
	3	199,3	-	4,8	9,5	4	15	M140×2	98	144	216	2,5	0,33	2,07	3,09	2,03
	4	239,5	162,2	9,5	17,7	4	19	M140×2	115	147	263	3	0,33	2,06	3,06	2,01
135	2	192,3	155,4	4,8	9,5	5	14	M150×2	68	148,8	201,2	2	0,22	3,07	4,57	3
	2	192,3	-	4,8	9,5	5	14	M150×2	68	148,8	201,2	2	0,22	3,07	4,57	3
	2	186,4	157,1	3,2	6,5	10	14	M145×2	83	148,8	201,2	2	0,28	2,37	3,53	2,32
	2,1	201	157,1	4,8	9,5	5	14	M150×2	83	152	213	2,1	0,27	2,49	3,71	2,43
	2,1	201	-	4,8	9,5	5	14	M150×2	83	152	213	2,1	0,27	2,49	3,71	2,43
	2,1	194,4	158,9	4,8	9,5	10	14	M150×2	99	152	213	2,1	0,34	1,99	2,96	1,94
	3	223,1	164,9	6,3	12,2	5	14	M150×2	83	154	236	2,5	0,25	2,67	3,97	2,61
	3	216	162	6,3	12,2	5	15	M150×2	104	154	236	2,5	0,33	2,04	3,04	2
	3	216	-	6,3	12,2	5	15	M150×2	104	154	236	2,5	0,33	2,04	3,04	2
	4	255,7	173,5	9,5	17,7	5	20	M150×2	125	157	283	3	0,34	2	2,98	1,96



Spherical roller bearings

With withdrawal sleeve

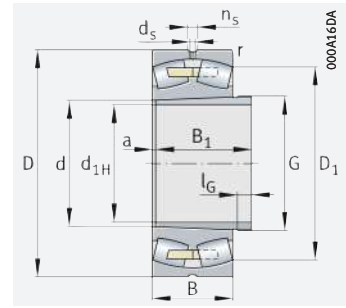
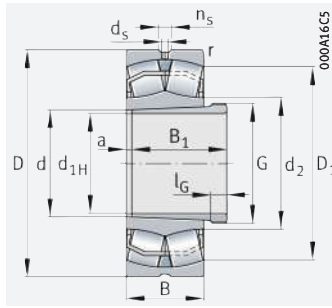

With solid cage, brass or steel

d_{1H} = 145 – 160 mm

Main dimensions				Basic load ratings		Fatigue limit load C _{ur}	Limiting speed n _G	Speed rating n _{dr}	Mass m		Designation	
d _{1H}	d	D	B	dyn. C _r	stat. C _{Or}				Bearing	Withdrawal sleeve	Bearing	Withdrawal sleeve
				kN	kN	N	min ⁻¹	min ⁻¹	≈ kg	≈ kg		
145	150	225	56	630	880	85 000	3 250	2 210	7,3	1,18	23030-E1-XL-K-TVPB	AHX3030
	150	225	56	630	880	85 000	3 250	2 210	7,3	1,18	23030-E1A-XL-K-M	AHX3030
	150	225	75	680	1 090	122 000	2 750	1 790	10,7	1,12	24030-BE-XL-K30	AH24030
	150	250	80	1 000	1 330	141 000	2 650	1 720	14,5	1,66	23130-E1-XL-K-TVPB	AHX3130G
	150	250	80	1 000	1 330	141 000	2 650	1 720	15,8	1,66	23130-E1A-XL-K-M	AHX3130G
	150	250	100	1 050	1 520	148 000	2 370	1 270	20,2	1,63	24130-BE-XL-K30	AH24130
	150	270	73	1 010	1 210	111 000	2 900	2 050	17,8	1,66	22230-E1-XL-K	AHX3130G
	150	270	96	1 280	1 660	129 000	2 400	1 400	22,3	2,09	23230-E1-XL-K-TVPB	AHX3230G
	150	270	96	1 280	1 660	129 000	2 400	1 400	22,9	2,09	23230-E1A-XL-K-M	AHX3230G
	150	320	108	1 640	1 850	147 000	2 290	1 520	40,9	2,64	22330-E1-XL-K	AHX2330G
150	160	240	60	720	1 010	95 000	3 050	2 060	8,7	2,09	23032-E1-XL-K-TVPB	AH3032
	160	240	60	720	1 010	95 000	3 050	2 060	9,4	2,09	23032-E1A-XL-K-M	AH3032
	160	240	80	770	1 240	137 000	2 550	1 660	12,2	2,31	24032-BE-XL-K30	AH24032
	160	270	86	1 160	1 550	162 000	2 490	1 560	18,5	2,9	23132-E1-XL-K-TVPB	AH3132A
	160	270	86	1 160	1 550	162 000	2 490	1 560	18,6	2,9	23132-E1A-XL-K-M	AH3132A
	160	270	109	1 220	1 800	168 000	2 180	1 140	24,9	3,04	24132-BE-XL-K30	AH24132
	160	290	80	1 150	1 400	125 000	2 650	1 900	22,4	2,9	22232-E1-XL-K	AH3132A
	160	290	104	1 460	1 910	146 000	2 210	1 280	27,7	3,65	23232-E1-XL-K-TVPB	AH3232G
	160	290	104	1 460	1 910	146 000	2 210	1 280	28,5	3,65	23232-E1A-XL-K-M	AH3232G
	160	340	114	1 680	1 990	157 000	2 250	1 420	47,3	4,26	22332-BE-XL-K	AH2332G
160	170	260	67	880	1 230	148 000	2 800	1 890	11,9	2,48	23034-E1-XL-K-TVPB	AH3034
	170	260	67	880	1 230	148 000	2 800	1 890	12,5	2,48	23034-E1A-XL-K-M	AH3034
	170	260	90	940	1 480	158 000	2 380	1 540	16,5	2,76	24034-BE-XL-K30	AH24034
	170	280	88	1 220	1 690	173 000	2 380	1 460	19,9	3,12	23134-E1-XL-K-TVPB	AH3134A
	170	280	88	1 220	1 690	173 000	2 380	1 460	19,5	3,12	23134-E1A-XL-K-M	AH3134A
	170	280	109	1 260	1 900	179 000	2 110	1 060	25,9	3,27	24134-BE-XL-K30	AH24134
	170	310	86	1 320	1 570	140 000	2 550	1 780	27,1	3,12	22234-E1-XL-K	AH3134A
	170	310	110	1 640	2 170	163 000	2 090	1 160	33,1	4,29	23234-E1-XL-K-TVPB	AH3234G
	170	310	110	1 640	2 170	163 000	2 090	1 160	34,6	4,29	23234-E1A-XL-K-M	AH3234G
	170	360	120	1 870	2 220	173 000	2 130	1 320	56,9	4,78	22334-BE-XL-K	AH2334G

medias ► <https://www.schaeffler.de/std/1EF1>

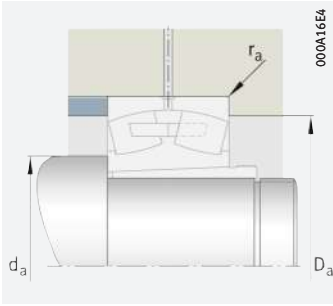

Mounting dimensions

Dimensions										Mounting dimensions			Calculation factors			
d_{1H}	r	D_1	d_2	d_s	n_s	a	l_G	Thread G	B_1	d_a	D_a	r_a	e	Y_1	Y_2	Y_0
	min.	≈	≈			≈				min.	max.	max.				
145	2,1	206,3	166,6	4,8	9,5	5	15	M160×3	72	160,2	214,8	2,1	0,22	3,1	4,62	3,03
	2,1	206,3	-	4,8	9,5	5	15	M160×3	72	160,2	214,8	2,1	0,22	3,1	4,62	3,03
	2,1	199,4	168,1	3,2	6,5	11	15	M155×3	90	160,2	214,8	2,1	0,29	2,32	3,45	2,26
	2,1	220,8	170,1	6,3	12,2	5	15	M160×3	96	162	238	2,1	0,29	2,32	3,45	2,26
	2,1	220,8	-	6,3	12,2	5	15	M160×3	96	162	238	2,1	0,29	2,32	3,45	2,26
	2,1	213	170,3	4,8	9,5	11	15	M160×3	115	162	238	2,1	0,37	1,83	2,72	1,79
	3	240,8	177,9	8	15	5	15	M160×3	96	164	256	2,5	0,25	2,69	4	2,63
	3	232,6	174	6,3	12,2	5	17	M160×3	114	164	256	2,5	0,33	2,02	3	1,97
	3	232,6	-	6,3	12,2	5	17	M160×3	114	164	256	2,5	0,33	2,02	3	1,97
	4	273,2	185,3	9,5	17,7	5	24	M160×3	135	167	303	3	0,33	2,02	3	1,97
150	2,1	219,9	177	6,3	12,2	5	16	M170×3	77	170,2	229,8	2,1	0,22	3,1	4,62	3,03
	2,1	219,9	-	6,3	12,2	5	16	M170×3	77	170,2	229,8	2,1	0,22	3,1	4,62	3,03
	2,1	212,5	179,3	4,8	9,5	11	15	M170×3	95	170,2	229,8	2,1	0,29	2,32	3,45	2,26
	2,1	238,3	183,2	8	15	5	16	M170×3	103	172	258	2,1	0,29	2,32	3,45	2,26
	2,1	238,3	-	8	15	5	16	M170×3	103	172	258	2,1	0,29	2,32	3,45	2,26
	2,1	228,9	183,4	4,8	9,5	11	15	M170×3	124	172	258	2,1	0,37	1,8	2,69	1,76
	3	258,2	190,9	8	15	5	16	M170×3	103	174	276	2,5	0,26	2,64	3,93	2,58
	3	249,3	186,7	8	15	6	20	M170×3	124	174	276	2,5	0,34	2	2,98	1,96
	3	249,3	-	8	15	6	20	M170×3	124	174	276	2,5	0,34	2	2,98	1,96
	4	286,7	201,2	9,5	17,7	6	24	M170×3	140	177	323	3	0,35	1,94	2,88	1,89
160	2,1	237,2	189,8	6,3	12,2	5	17	M180×3	85	180,2	249,8	2,1	0,23	2,98	4,44	2,92
	2,1	237,2	-	6,3	12,2	5	17	M180×3	85	180,2	249,8	2,1	0,23	2,98	4,44	2,92
	2,1	228,4	190	4,8	9,5	11	16	M180×3	106	180,2	249,8	2,1	0,31	2,2	3,27	2,15
	2,1	248,1	193,4	8	15	5	16	M180×3	104	182	268	2,1	0,28	2,37	3,53	2,32
	2,1	248,1	-	8	15	5	16	M180×3	104	182	268	2,1	0,28	2,37	3,53	2,32
	2,1	240	194,1	4,8	9,5	11	16	M180×3	125	182	268	2,1	0,36	1,9	2,83	1,86
	4	275,4	199,8	9,5	17,7	5	16	M180×3	104	187	293	3	0,26	2,6	3,87	2,54
	4	267,4	199,8	8	15	6	24	M180×3	134	187	293	3	0,33	2,03	3,02	1,98
	4	267,4	-	8	15	6	24	M180×3	134	187	293	3	0,33	2,03	3,02	1,98
	4	303,9	213,1	9,5	17,7	6	24	M180×3	146	187	343	3	0,35	1,95	2,9	1,91



Spherical roller bearings

With withdrawal sleeve

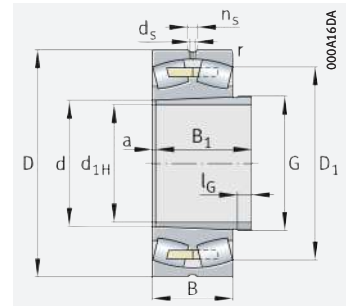
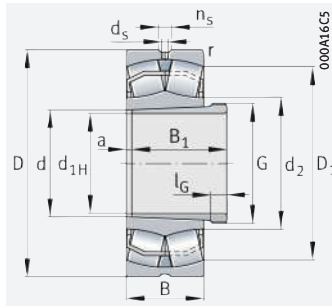

With solid cage, brass or steel

d_{1H} = 170 – 190 mm

Main dimensions				Basic load ratings		Fatigue limit load C _{ur}	Limiting speed n _G	Speed rating n _{Dr}	Mass m		Designation	
d _{1H}	d	D	B	dyn. C _r	stat. C _{Or}				Bearing	With- drawal sleeve	Bearing	With- drawal sleeve
				kN	kN	N	min ⁻¹	min ⁻¹	≈ kg	≈ kg		
170	180	250	52	445	840	57 000	3 200	1 850	7,8	1,96	23936-S-K-MB	AH3936
	180	280	74	1 040	1 450	169 000	2 600	1 760	15,6	2,87	23036-E1-XL-K-TVPB	AH3036
	180	280	74	1 040	1 450	169 000	2 600	1 760	16	2,87	23036-E1A-XL-K-M	AH3036
	180	280	100	1 130	1 770	180 000	2 200	1 420	21,8	3,21	24036-BE-XL-K30	AH24036
	180	300	96	1 420	1 950	194 000	2 230	1 350	25,9	3,79	23136-E1-XL-K-TVPB	AH3136A
	180	300	96	1 420	1 950	194 000	2 230	1 350	25,5	3,79	23136-E1A-XL-K-M	AH3136A
	180	300	118	1 460	2 170	203 000	2 000	980	32,5	3,74	24136-BE-XL-K30	AH24136
	180	320	86	1 360	1 680	148 000	2 470	1 670	28,5	3,35	22236-E1-XL-K	AH2236G
	180	320	112	1 720	2 340	173 000	2 010	1 090	36	4,8	23236-E1-XL-K-TVPB	AH3236G
	180	320	112	1 720	2 340	173 000	2 010	1 090	37	4,8	23236-E1A-XL-K-M	AH3236G
180	380	126	2 060	2 460	190 000	2 030	1 230	66,6	5,42	22336-BE-XL-K	AH2336G	
180	190	290	75	1 080	1 550	179 000	2 490	1 660	16,3	3,19	23038-E1-XL-K-TVPB	AH3038G
	190	290	75	1 080	1 550	179 000	2 490	1 660	17,7	3,19	23038-E1A-XL-K-M	AH3038G
	190	290	100	1 160	1 860	192 000	2 140	1 330	22,8	3,48	24038-BE-XL-K30	AH24038
	190	320	104	1 610	2 220	216 000	2 070	1 260	30,3	4,39	23138-E1-XL-K-TVPB	AH3138G
	190	320	104	1 610	2 220	216 000	2 070	1 260	32,4	4,39	23138-E1A-XL-K-M	AH3138G
	190	320	128	1 680	2 550	226 000	1 850	880	40,7	4,37	24138-BE-XL-K30	AH24138
	190	340	92	1 360	1 760	159 000	2 480	1 620	36	3,83	22238-BE-XL-K	AH2238G
	190	340	120	1 740	2 400	200 000	1 990	1 070	42,6	5,3	23238-BE-XL-K	AH3238G
	190	400	132	2 220	2 650	207 000	1 940	1 160	77,2	6,02	22338-BE-XL-K	AH2338G
190	200	280	60	550	1 070	71 000	2 800	1 650	11,5	2,62	23940-S-K-MB	AH3940
	200	310	82	1 270	1 800	202 000	2 330	1 550	20,8	3,62	23040-E1-XL-K-TVPB	AH3040G
	200	310	82	1 270	1 800	202 000	2 330	1 550	21,4	3,62	23040-E1A-XL-K-M	AH3040G
	200	310	109	1 350	2 150	215 000	2 010	1 240	28,9	3,96	24040-BE-XL-K30	AH24040
	200	340	112	1 610	2 270	188 000	2 040	1 230	40,9	5,6	23140-BE-XL-K	AH3140
	200	340	140	1 880	2 800	250 000	1 780	840	48,5	5,02	24140-BE-XL-K30	AH24140
	200	360	98	1 520	1 990	175 000	2 330	1 510	42,3	4,8	22240-BE-XL-K	AH2240
	200	360	128	1 940	2 700	219 000	1 870	1 000	57,3	6,61	23240-BE-XL-K	AH3240
	200	420	138	2 440	2 950	225 000	1 830	1 080	87,4	7,64	22340-BE-XL-K	AH2340

medias ► <https://www.schaeffler.de/std/1EF2>

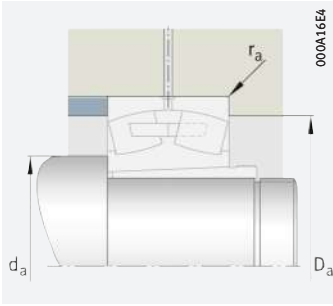

Mounting dimensions

Dimensions										Mounting dimensions			Calculation factors			
d_{1H}	r	D_1	d_2	d_s	n_s	a	l_G	Thread G	B_1	d_a	D_a	r_a	e	Y_1	Y_2	Y_0
	min.	≈	≈			≈				min.	max.	max.				
170	2	230,9	-	4,8	9,5	5	13	M190×3	66	188,8	241,2	2	0,2	3,42	5,09	3,34
	2,1	254,3	201,8	8	15	6	17	M190×3	92	190,2	269,8	2,1	0,23	2,9	4,31	2,83
	2,1	254,3	-	8	15	6	17	M190×3	92	190,2	269,8	2,1	0,23	2,9	4,31	2,83
	2,1	244,6	201,7	4,8	9,5	11	16	M190×3	116	190,2	269,8	2,1	0,32	2,1	3,13	2,06
	3	264,8	204,1	8	15	6	19	M190×3	116	194	286	2,5	0,29	2,32	3,45	2,26
	3	264,8	-	8	15	6	19	M190×3	116	194	286	2,5	0,29	2,32	3,45	2,26
	3	255,7	204,8	6,3	12,2	11	16	M190×3	134	194	286	2,5	0,36	1,86	2,77	1,82
	4	285,9	211,3	9,5	17,7	5	17	M190×3	105	197	303	3	0,25	2,71	4,04	2,65
	4	277,3	210,6	8	15	6	25	M190×3	140	197	303	3	0,33	2,07	3,09	2,03
	4	277,3	-	8	15	6	25	M190×3	140	197	303	3	0,33	2,07	3,09	2,03
4	320,8	224,9	12,5	23,5	6	26	M190×3	154	197	363	3	0,34	1,96	2,92	1,92	
180	2,1	264,5	211,9	8	15	6	18	M200×3	96	200,2	279,8	2,1	0,23	2,98	4,44	2,92
	2,1	264,5	-	8	15	6	18	M200×3	96	200,2	279,8	2,1	0,23	2,98	4,44	2,92
	2,1	255	211,9	4,8	9,5	13	18	M200×3	118	200,2	279,8	2,1	0,31	2,2	3,27	2,15
	3	281,6	217	8	15	6	20	M200×3	125	204	306	2,5	0,3	2,28	3,39	2,23
	3	281,6	-	8	15	6	20	M200×3	125	204	306	2,5	0,3	2,28	3,39	2,23
	3	271,6	217,4	6,3	12,2	13	18	M200×3	146	204	306	2,5	0,37	1,82	2,7	1,78
	4	295,2	225,2	9,5	17,7	5	18	M200×3	112	207	323	3	0,26	2,6	3,87	2,54
	4	289	222,4	9,5	17,7	7	25	M200×3	145	207	323	3	0,34	1,98	2,94	1,93
	5	338,1	236,8	12,5	23,5	7	26	M200×3	160	210	380	4	0,34	1,96	2,92	1,92
190	2,1	256,9	-	6,3	12,2	6	16	Tr210×4	77	210,2	269,8	2,1	0,2	3,42	5,09	3,34
	2,1	281,6	223,4	8	15	6	19	Tr210×4	102	210,2	299,8	2,1	0,23	2,9	4,31	2,83
	2,1	281,6	-	8	15	6	19	Tr210×4	102	210,2	299,8	2,1	0,23	2,9	4,31	2,83
	2,1	271,6	223,6	6,3	12,2	13	18	Tr210×4	127	210,2	299,8	2,1	0,32	2,13	3,17	2,08
	3	295,8	230,4	9,5	17,7	6	21	Tr220×4	134	214	326	2,5	0,32	2,1	3,13	2,06
	3	287,9	227,1	6,3	12,2	13	18	Tr210×4	158	214	326	2,5	0,39	1,71	2,54	1,67
	4	310,9	238,2	9,5	17,7	5	19	Tr220×4	118	217	343	3	0,26	2,57	3,83	2,52
	4	305,3	235	9,5	17,7	7	24	Tr220×4	153	217	343	3	0,35	1,95	2,9	1,91
	5	355,1	248,8	12,5	23,5	7	30	Tr220×4	170	220	400	4	0,34	1,98	2,94	1,93



Spherical roller bearings

With withdrawal sleeve

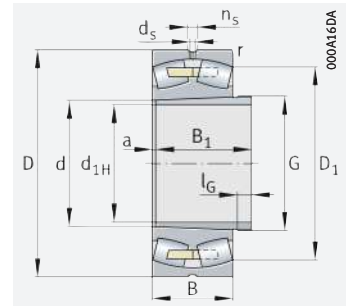
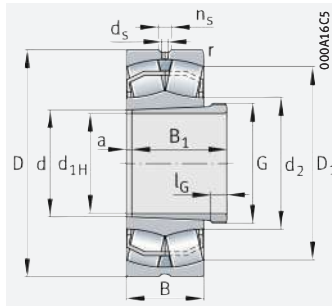

With solid cage, brass or steel

d_{1H} = 200 – 260 mm

Main dimensions				Basic load ratings		Fatigue limit load C _{ur}	Limiting speed n _G	Speed rating n _{Dr}	Mass m		Designation	
d _{1H}	d	D	B	dyn. C _r	stat. C _{Or}				Bearing	With- drawal sleeve	Bearing	With- drawal sleeve
				kN	kN	N	min ⁻¹	min ⁻¹	≈ kg	≈ kg		
200	220	300	60	610	1 240	72 000	2 600	1 460	12,3	4,81	23944-S-K-MB	AH3944
	220	340	90	1 260	1 900	177 000	2 230	1 450	28,5	7,18	23044-BE-XL-K	AH3044G
	220	340	118	1 620	2 600	250 000	1 830	1 090	37,7	8,22	24044-BE-XL-K30	AH24044
	220	370	120	1 860	2 700	217 000	1 860	1 080	50,5	10,4	23144-BE-XL-K	AH3144
	220	370	150	2 190	3 250	290 000	1 650	750	62,7	10,3	24144-BE-XL-K30	AH24144
	220	400	108	1 840	2 360	210 000	2 140	1 350	58,3	9,17	22244-BE-XL-K	AH2244
	220	400	144	2 380	3 300	265 000	1 700	880	75,3	13,6	23244-BE-XL-K	AH2344
	220	460	145	2 800	3 400	265 000	1 690	950	114	13,6	22344-BE-XL-K	AH2344
220	240	320	60	640	1 370	93 000	2 440	1 310	13,4	5,26	23948-K-MB	AH3948
	240	360	92	1 350	2 120	194 000	2 080	1 310	31,6	8,92	23048-BE-XL-K	AH3048
	240	360	118	1 670	2 850	275 000	1 710	980	42,3	9,03	24048-BE-XL-K30	AH24048
	240	400	128	2 130	3 150	248 000	1 700	970	62	12,3	23148-BE-XL-K	AH3148
	240	400	160	2 600	3 900	330 000	1 470	650	81,5	12,6	24148-BE-XL-K30	AH24148
	240	440	120	2 230	2 900	247 000	1 900	1 200	81,8	11,3	22248-BE-XL-K	AH2248
	240	440	160	2 850	4 000	310 000	1 500	770	102	15,6	23248-BE-XL-K	AH2348
	240	500	155	3 200	4 050	305 000	1 510	830	148	15,6	22348-BEA-XL-K-MB1	AH2348
240	260	360	75	940	1 940	108 000	2 100	1 190	22,4	7,7	23952-K-MB	AH3952G
	260	400	104	1 670	2 600	233 000	1 850	1 170	45,9	10,8	23052-BE-XL-K	AH3052
	260	400	140	2 210	3 650	335 000	1 510	880	61,2	11,6	24052-BE-XL-K30	AH24052
	260	440	144	2 600	3 900	305 000	1 500	860	87,2	15,1	23152-BE-XL-K	AH3152G
	260	440	180	3 150	4 900	390 000	1 290	560	108	15,5	24152-BE-XL-K30	AH24152
	260	480	130	2 600	3 450	290 000	1 720	1 070	104	13,3	22252-BEA-XL-K-MB1	AH2252G
	260	480	174	3 350	4 750	360 000	1 360	690	134	18,7	23252-BEA-XL-K-MB1	AH2352G
	260	540	165	3 650	4 650	350 000	1 390	740	179	18,7	22352-BEA-XL-K-MB1	AH2352G
260	280	380	75	970	2 040	129 000	2 000	1 100	24,7	8,3	23956-K-MB	AH3956G
	280	420	106	1 780	2 850	255 000	1 740	1 090	49,3	12	23056-BE-XL-K	AH3056
	280	420	140	2 290	3 950	360 000	1 420	800	67,8	12,6	24056-BE-XL-K30	AH24056
	280	460	146	2 750	4 200	315 000	1 420	790	93,1	16,7	23156-BE-XL-K	AH3156G
	280	460	180	3 300	5 200	425 000	1 230	520	114	16,7	24156-BE-XL-K30	AH24156
	280	500	130	2 750	3 700	310 000	1 650	990	109	14,4	22256-BEA-XL-K-MB1	AH2256G
	280	500	176	3 550	5 200	385 000	1 280	630	143,7	20,9	23256-BEA-XL-K-MB1	AH2356G
	280	580	175	4 150	5 300	395 000	1 280	670	223	20,9	22356-BEA-XL-K-MB1	AH2356G

medias ► <https://www.schaeffler.de/std/1EF3>

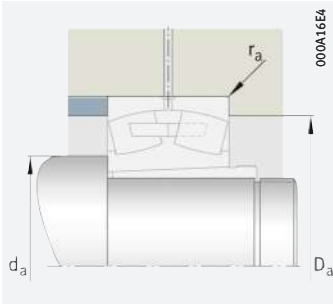

Mounting dimensions

Dimensions										Mounting dimensions			Calculation factors			
d_{1H}	r	D_1	d_2	d_s	n_s	a	l_G	Thread G	B_1	d_a	D_a	r_a	e	Y_1	Y_2	Y_0
	min.	≈	≈			≈				min.	max.	max.				
200	2,1	277,4	–	6,3	12,2	6	16	Tr230×4	77	230,2	289,8	2,1	0,18	3,76	5,59	3,67
	3	304,5	248,8	8	15	6	20	Tr230×4	111	232,4	327,6	2,5	0,24	2,81	4,19	2,75
	3	295,7	245	6,3	12,2	14	18	Tr230×4	138	232,4	327,6	2,5	0,32	2,1	3,13	2,06
	4	323	254,8	9,5	17,7	6	23	Tr240×4	145	237	353	3	0,31	2,15	3,2	2,1
	4	314,3	247,6	6,3	12,2	14	20	Tr230×4	170	237	353	3	0,39	1,74	2,59	1,7
	4	346,6	260,1	9,5	17,7	6	20	Tr240×4	130	237	383	3	0,26	2,57	3,83	2,52
	4	338	255,8	9,5	17,7	8	30	Tr240×4	181	237	383	3	0,36	1,9	2,83	1,86
	5	391,1	273,4	12,5	23,5	8	30	Tr240×4	181	240	440	4	0,33	2,06	3,06	2,01
220	2,1	297,8	–	6,3	12,2	6	16	Tr250×4	77	250,2	309,8	2,1	0,17	4,05	6,04	3,96
	3	324,6	269,5	8	15	7	21	Tr260×4	116	252,4	347,6	2,5	0,23	2,98	4,44	2,92
	3	317,2	268,5	6,3	12,2	15	20	Tr250×4	138	252,4	347,6	2,5	0,3	2,28	3,39	2,23
	4	349,9	275,9	9,5	17,7	7	25	Tr260×4	154	257	383	3	0,31	2,18	3,24	2,13
	4	339	267,3	6,3	12,2	15	20	Tr260×4	180	257	383	3	0,39	1,71	2,54	1,67
	4	380,4	285,6	12,5	23,5	6	21	Tr260×4	144	257	423	3	0,26	2,55	3,8	2,5
	4	370,8	280,8	12,5	23,5	8	30	Tr260×4	189	257	423	3	0,36	1,87	2,79	1,83
	5	426,4	–	12,5	23,5	8	30	Tr260×4	189	260	480	4	0,32	2,12	3,15	2,07
240	2,1	330,5	–	8	15	6	18	Tr280×4	94	270,2	349,8	2,1	0,19	3,54	5,27	3,46
	4	358,7	295,5	9,5	17,7	7	23	Tr280×4	128	274,6	385,4	3	0,23	2,9	4,31	2,83
	4	349	288,3	6,3	12,2	16	20	Tr270×4	162	274,6	385,4	3	0,32	2,09	3,11	2,04
	4	382,7	301,7	9,5	17,7	7	26	Tr280×4	172	277	423	3	0,32	2,12	3,15	2,07
	4	370,6	292,2	8	15	16	22	Tr280×4	202	277	423	3	0,4	1,67	2,49	1,63
	5	415,1	–	12,5	23,5	6	23	Tr280×4	155	280	460	4	0,26	2,57	3,83	2,52
	5	404,3	–	12,5	23,5	8	30	Tr280×4	205	280	460	4	0,36	1,87	2,79	1,83
	6	460,6	–	12,5	23,5	8	30	Tr280×4	205	286	514	5	0,31	2,15	3,2	2,1
260	2,1	350	–	8	15	6	18	Tr300×4	94	290,2	369,8	2,1	0,18	3,76	5,59	3,67
	4	379,2	314,3	9,5	17,7	8	24	Tr300×4	131	294,6	405,4	3	0,22	3,01	4,48	2,94
	4	370,5	310,3	6,3	12,2	17	22	Tr290×4	162	294,6	405,4	3	0,3	2,23	3,32	2,18
	5	403,4	321,4	9,5	17,7	8	28	Tr300×4	175	300	440	4	0,31	2,21	3,29	2,16
	5	392,4	312,8	8	15	17	22	Tr300×4	202	300	440	4	0,38	1,76	2,62	1,72
	5	436	–	12,5	23,5	8	24	Tr300×4	155	300	480	4	0,25	2,71	4,04	2,65
	5	425,4	–	12,5	23,5	8	30	Tr300×4	212	300	480	4	0,34	1,96	2,92	1,92
	6	495,5	–	12,5	23,5	8	30	Tr300×4	212	306	554	5	0,31	2,18	3,24	2,13



Spherical roller bearings

With withdrawal sleeve

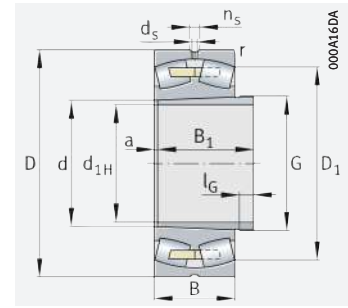
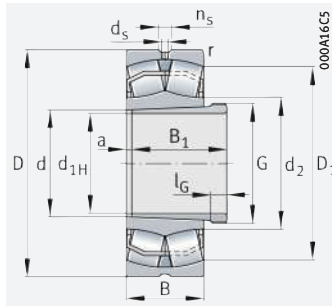

With solid cage, brass or steel

d_{1H} = 280 – 360 mm

Main dimensions				Basic load ratings		Fatigue limit load C _{ur}	Limiting speed n _G	Speed rating n _{dr}	Mass m		Designation ▶681 1.12 ▶683 1.13 X-life ▶671	Bearing	With- drawal sleeve
d _{1H}	d	D	B	dyn. C _r	stat. C _{Or}				Bearing	With- drawal sleeve			
				kN	kN	N	min ⁻¹	min ⁻¹	≈ kg	≈ kg			
280	300	420	90	1 270	2 650	165 000	1 780	1 000	39,1	10,8	23960-B-K-MB	AH3960G	
	300	460	118	2 160	3 450	295 000	1 570	980	68,4	14,4	23060-BE-XL-K	AH3060	
	300	460	160	2 850	4 900	425 000	1 250	720	97	15,5	24060-BE-XL-K30	AH24060	
	300	500	160	3 250	4 950	365 000	1 300	720	126	20	23160-BEA-XL-K-MB1	AH3160G	
	300	500	200	3 950	6 400	485 000	1 100	450	161	20,1	24160-BE-XL-K30	AH24160	
	300	540	140	3 100	4 250	355 000	1 500	900	139	17,2	22260-BEA-XL-K-MB1	AH2260G	
	300	540	192	4 100	6 100	440 000	1 160	560	187	24,6	23260-BEA-XL-K-MB1	AH3260G-H	
300	320	440	90	1 310	2 750	201 000	1 700	930	41	11,5	23964-K-MB	AH3964G-H	
	320	480	121	2 300	3 750	320 000	1 480	920	75,6	15,9	23064-BEA-XL-K-MB1	AH3064G-H	
	320	480	160	2 950	5 200	455 000	1 200	670	99	16,6	24064-BEA-XL-K30-MB1	AH24064-H	
	320	540	176	3 800	5 900	415 000	1 170	650	161	23,6	23164-BEA-XL-K-MB1	AH3164G-H	
	320	540	218	4 600	7 300	560 000	1 010	415	205	23,4	24164-BE-XL-K30	AH24164-H	
	320	580	150	3 550	4 700	395 000	1 410	830	171	19,6	22264-BEA-XL-K-MB1	AH2264G-H	
	320	580	208	4 650	7 000	495 000	1 060	510	229,6	28,9	23264-BEA-XL-K-MB1	AH3264G-H	
320	340	520	133	2 700	4 400	365 000	1 360	840	101	18,6	23068-BEA-XL-K-MB1	AH3068G-H	
	340	520	180	3 550	6 200	520 000	1 080	610	136	21,1	24068-BEA-XL-K30-MB1	AH24068-H	
	340	580	190	4 350	6 600	465 000	1 090	600	204	27,5	23168-BEA-XL-K-MB1	AH3168G-H	
	340	580	243	5 400	8 800	620 000	900	370	263	28	24168-BE-XL-K30	AH24168-H	
	340	620	224	5 300	7 900	570 000	1 000	475	292	33,6	23268-BEA-XL-K-MB1	AH3268G-H	
340	360	480	90	1 440	3 200	210 000	1 540	800	45	13	23972-K-MB	AH3972G-H	
	360	540	134	2 800	4 650	390 000	1 300	790	104	20,5	23072-BEA-XL-K-MB1	AH3072G-H	
	360	540	180	3 650	6 600	550 000	1 040	570	141	22,3	24072-BEA-XL-K30-MB1	AH24072-H	
	360	600	192	4 550	7 100	495 000	1 040	560	215	29,8	23172-BEA-XL-K-MB1	AH3172G-H	
	360	600	243	5 600	9 100	660 000	890	350	272	29,7	24172-BE-XL-K30	AH24172-H	
	360	650	232	5 700	8 900	610 000	930	430	330,5	37,3	23272-BEA-XL-K-MB1	AH3272G-H	
360	380	520	106	1 780	4 000	265 000	1 340	750	66,3	16,1	23976-K-MB	AH3976G-H	
	380	560	135	2 900	5 000	410 000	1 230	740	109	22,1	23076-BEA-XL-K-MB1	AH3076G-H	
	380	560	180	3 750	7 000	590 000	990	530	151	24	24076-BEA-XL-K30-MB1	AH24076-H	
	380	620	194	4 700	7 600	530 000	990	530	227	32	23176-BEA-XL-K-MB1	AH3176G-H	
	380	620	243	5 800	9 700	710 000	850	325	285	31,8	24176-BE-XL-K30	AH24176-H	
	380	680	240	6 200	9 600	660 000	890	400	374	41,3	23276-BEA-XL-K-MB1	AH3276G-H	

medias ▶ <https://www.schaeffler.de/std/1EF4>

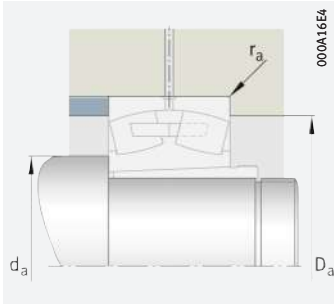

Mounting dimensions

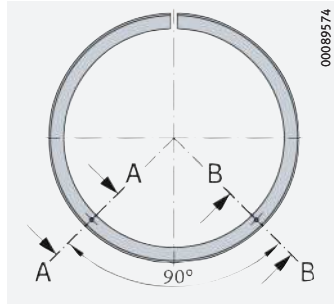

Pump connectors for hydraulic withdrawal sleeve

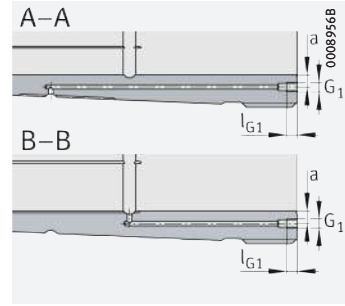

Hydraulic withdrawal sleeve (...H) Mounting dimensions

Dimensions

Mounting dimensions

Calculation factors

d _{1H}	r	D ₁	d ₂	d _s	n _s	a	l _G	Thread G	B ₁	d _a	D _a	r _a	G ₁	a	l _{G1}	e	Y ₁	Y ₂	Y ₀
280	3	384,6	–	9,5	17,7	7	21	Tr320×5	112	312,4	407,6	2,5	–	–	–	0,2	3,42	5,09	3,34
	4	413	340	9,5	17,7	8	26	Tr320×5	145	314,6	445,4	3	–	–	–	0,23	2,92	4,35	2,86
	4	403	334,8	8	15	18	24	Tr310×5	184	314,6	445,4	3	–	–	–	0,32	2,12	3,15	2,07
	5	436,8	–	9,5	17,7	8	30	Tr320×5	192	320	480	4	–	–	–	0,31	2,18	3,24	2,13
	5	422,8	338,2	8	15	18	24	Tr320×5	224	320	480	4	–	–	–	0,39	1,72	2,56	1,68
	5	470,5	–	12,5	23,5	8	26	Tr320×5	170	320	520	4	–	–	–	0,25	2,71	4,04	2,65
	5	458	–	12,5	23,5	8	34	Tr320×5	228	320	520	4	G ¹ / ₈	8,5	12	0,35	1,92	2,86	1,88
300	3	406,2	–	9,5	17,7	7	21	Tr340×5	112	332,4	427,6	2,5	M8	8,5	12	0,19	3,62	5,39	3,54
	4	433	–	9,5	17,7	8	27	Tr340×5	149	334,6	465,4	3	G ¹ / ₈	8,5	12	0,22	3,01	4,48	2,94
	4	422,3	–	8	15	18	24	Tr330×5	184	334,6	465,4	3	M6	8,5	7	0,3	2,23	3,32	2,18
	5	469,3	–	12,5	23,5	8	31	Tr340×5	209	340	520	4	G ¹ / ₈	8,5	12	0,32	2,13	3,17	2,08
	5	455,5	359	9,5	17,7	18	24	Tr340×5	242	340	520	4	G ¹ / ₈	8,5	12	0,4	1,69	2,52	1,65
	5	505,1	–	12,5	23,5	10	27	Tr340×5	180	340	560	4	G ¹ / ₈	8,5	12	0,25	2,71	4,04	2,65
	5	490,4	–	12,5	23,5	8	36	Tr340×5	246	340	560	4	G ¹ / ₈	8,5	12	0,35	1,91	2,85	1,87
320	5	467,1	–	12,5	23,5	9	28	Tr360×5	162	358	502	4	G ¹ / ₈	8,5	12	0,23	2,92	4,35	2,86
	5	456,1	–	9,5	17,7	19	26	Tr360×5	206	358	502	4	G ¹ / ₈	8,5	12	0,32	2,12	3,15	2,07
	5	502,6	–	12,5	23,5	9	33	Tr360×5	225	360	560	4	G ¹ / ₈	8,5	12	0,32	2,1	3,13	2,06
	5	484,1	382,8	9,5	17,7	19	26	Tr360×5	269	360	560	4	G ¹ / ₈	8,5	12	0,42	1,62	2,42	1,59
	6	523,5	–	12,5	23,5	9	38	Tr360×5	264	366	594	5	G ¹ / ₈	8,5	12	0,36	1,85	2,76	1,81
340	3	447,1	–	9,5	17,7	7	21	Tr380×5	112	372,4	467,6	2,5	M8	8,5	12	0,17	4,05	6,04	3,96
	5	487,6	–	12,5	23,5	9	30	Tr380×5	167	378	522	4	G ¹ / ₈	8,5	12	0,22	3,04	4,53	2,97
	5	476,4	–	9,5	17,7	20	26	Tr380×5	206	378	522	4	G ¹ / ₈	8,5	12	0,3	2,23	3,32	2,18
	5	523,3	–	12,5	23,5	9	35	Tr380×5	229	380	580	4	G ¹ / ₈	8,5	12	0,31	2,18	3,24	2,13
	5	505,9	399,4	9,5	17,7	20	26	Tr380×5	269	380	580	4	G ¹ / ₈	8,5	12	0,4	1,69	2,52	1,65
	6	550,8	–	12,5	23,5	9	40	Tr380×5	274	386	624	5	G ¹ / ₈	8,5	12	0,36	1,9	2,83	1,86
360	4	477,6	–	9,5	17,7	8	22	Tr400×5	130	394,6	505,4	3	M8	8,5	12	0,19	3,58	5,33	3,5
	5	508,1	–	12,5	23,5	10	31	Tr400×5	170	398	542	4	G ¹ / ₈	8,5	12	0,21	3,17	4,72	3,1
	5	497,9	–	9,5	17,7	20	28	Tr400×5	208	398	542	4	G ¹ / ₈	8,5	12	0,29	2,33	3,47	2,28
	5	543,6	–	12,5	23,5	10	36	Tr400×5	232	400	600	4	G ¹ / ₈	8,5	12	0,3	2,25	3,34	2,2
	5	528,4	421	9,5	17,7	20	28	Tr400×5	271	400	600	4	G ¹ / ₈	8,5	12	0,38	1,76	2,62	1,72
	6	578,1	–	12,5	23,5	10	42	Tr400×5	284	406	654	5	G ¹ / ₈	8,5	12	0,35	1,92	2,86	1,88



Spherical roller bearings

With withdrawal sleeve

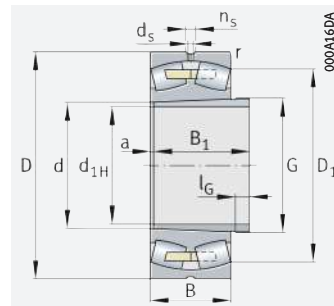
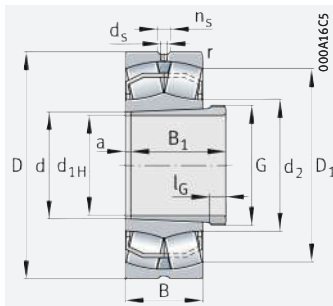

With solid cage, brass or steel

d_{1H} = 380 – 480 mm

Main dimensions				Basic load ratings		Fatigue limit load C _{ur} N	Limiting speed n _G min ⁻¹	Speed rating n _{gr} min ⁻¹	Mass m		Designation	
d _{1H}	d	D	B	dyn. C _r kN	stat. C _{0r} kN				Bearing ≈ kg	With- drawal sleeve ≈ kg	Bearing	With- drawal sleeve
380	400	540	106	1 830	4 150	270 000	1 290	710	68,2	17	23980-B-K-MB	AH3980G-H
	400	600	148	3 400	5 700	465 000	1 150	690	144	25,4	23080-BEA-XL-K-MB1	AH3080G-H
	400	600	200	4 500	8 100	660 000	920	495	196	27,8	24080-BEA-XL-K30-MB1	AH24080-H
	400	650	200	5 000	8 100	570 000	950	495	246	35,1	23180-BEA-XL-K-MB1	AH3180G-H
400	420	560	106	1 910	4 450	300 000	1 230	660	72,1	17,8	23984-K-MB	AH3984G-H
	420	620	150	3 650	6 300	510 000	1 090	650	153	27,2	23084-BEA-XL-K-MB1	AH3084G-H
	420	620	200	4 600	8 500	710 000	890	465	205	29,6	24084-BEA-XL-K30-MB1	AH24084-H
	420	700	224	6 000	9 600	650 000	860	455	342	42	23184-BEA-XL-K-MB1	AH3184G-H
	420	700	280	7 400	12 600	860 000	720	270	431	41	24184-BE-XL-K30	AH24184-H
	420	760	272	7 800	12 300	800 000	770	340	537	53,6	23284-BEA-XL-K-MB1	AH3284G-H
420	440	600	118	2 230	5 200	295 000	1 130	620	98,3	21,2	23988-K-MB	AH3988-H
	440	650	157	3 950	6 900	550 000	1 030	610	176	30	23088-BEA-XL-K-MB1	AHX3088G-H
	440	650	212	5 100	9 500	760 000	830	435	238	32,8	24088-BEA-XL-K30-MB1	AH24088-H
	440	720	226	6 200	10 200	680 000	820	430	358	44,9	23188-BEA-XL-K-MB1	AHX3188G-H
	440	720	280	7 600	12 900	910 000	710	260	446	42,9	24188-BE-XL-K30	AH24188-H
	440	790	280	8 300	13 200	860 000	730	320	592	58,2	23288-BEA-XL-K-MB1	AHX3288G-H
440	460	620	118	2 270	5 400	370 000	1 080	590	103	22,2	23992-B-K-MB	AH3992-H
	460	680	163	4 300	7 500	590 000	980	580	201	32,9	23092-BEA-XL-K-MB1	AHX3092G-H
	460	760	240	6 900	11 500	740 000	770	395	431	50,3	23192-BEA-XL-K-MB1	AHX3192G-H
	460	760	300	8 500	14 500	1 000 000	660	241	531	48,7	24192-BEA-XL-K30-MB1	AH24192-H
	460	830	296	9 200	14 700	930 000	690	295	695	65,6	23292-BEA-XL-K-MB1	AHX3292G-H
460	480	650	128	2 550	6 000	460 000	1 040	570	121	25,7	23996-B-K-MB	AH3996-H
	480	700	165	4 450	8 000	620 000	950	550	210	35	23096-BEA-XL-K-MB1	AHX3096G-H
	480	700	218	5 600	10 700	860 000	770	385	279	37,2	24096-BEA-XL-K30-MB1	AH24096-H
	480	790	248	7 400	12 400	790 000	740	375	479	54,8	23196-BEA-XL-K-MB1	AHX3196G-H
	480	790	308	9 000	15 500	1 070 000	640	227	594	52,9	24196-BEA-XL-K30-MB1	AH24196-H
	480	870	310	10 000	16 200	1 010 000	650	275	804	72,4	23296-BEA-XL-K-MB1	AHX3296G-H
	480	830	325	10 000	17 300	1 160 000	600	209	692	58,8	241/500-BEA-XL-K30-MB1	AH241/500-H
480	500	670	128	2 600	6 300	400 000	990	540	124	27,7	239/500-K-MB	AH39/500-H
	500	720	167	4 700	8 700	750 000	890	510	223	42,5	230/500-BEA-XL-K-MB1	AHX30/500-H
	500	830	264	8 300	13 900	860 000	690	350	574	70,9	231/500-BEA-XL-K-MB1	AHX31/500-H
	500	830	325	10 000	17 300	1 160 000	600	209	692	58,8	241/500-BEA-XL-K30-MB1	AH241/500-H

medias ▶ <https://www.schaeffler.de/std/1EF5>

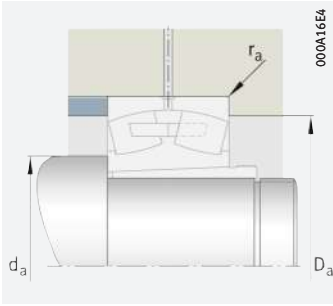

Mounting dimensions

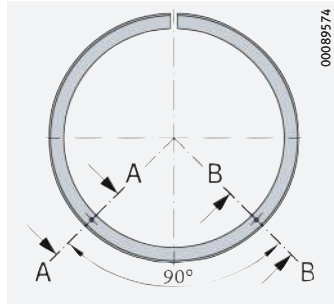

Pump connectors for hydraulic withdrawal sleeve

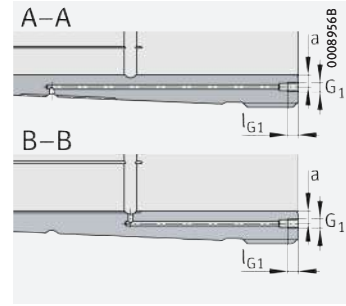

Hydraulic withdrawal sleeve (...H) Mounting dimensions

Dimensions										Mounting dimensions						Calculation factors			
d_{1H}	r	D_1	d_2	d_s	n_s	a	l_G	Thread G	B_1	d_a	D_a	r_a	G_1	a	l_{G1}	e	Y_1	Y_2	Y_0
	min.	≈	≈			≈				min.	max.	max.							
380	4	499	-	9,5	17,7	8	22	Tr420×5	130	414,6	525,4	3	M8	8,5	12	0,18	3,71	5,52	3,63
	5	541,9	-	12,5	23,5	10	33	Tr420×5	183	418	582	4	G ¹ / ₈	8,5	12	0,22	3,07	4,57	3
	5	529,4	-	12,5	23,5	20	28	Tr420×5	228	418	582	4	G ¹ / ₈	8,5	12	0,3	2,23	3,32	2,18
	6	571,4	-	12,5	23,5	10	38	Tr420×5	240	426	624	5	G ¹ / ₈	8,5	12	0,29	2,3	3,42	2,25
400	4	519,5	-	9,5	17,7	8	22	Tr440×5	130	434,6	545,4	3	M8	8,5	12	0,18	3,85	5,73	3,76
	5	560,7	-	12,5	23,5	10	34	Tr440×5	186	438	602	4	G ¹ / ₈	8,5	12	0,21	3,17	4,72	3,1
	5	551	-	12,5	23,5	22	30	Tr440×5	230	438	602	4	G ¹ / ₈	8,5	12	0,29	2,32	3,45	2,26
	6	609,8	-	12,5	23,5	10	40	Tr440×5	266	446	674	5	G ¹ / ₈	8,5	12	0,31	2,18	3,24	2,13
	6	592,2	472,7	12,5	23,5	22	30	Tr440×5	310	446	674	5	G ¹ / ₈	8,5	12	0,39	1,72	2,56	1,68
	7,5	643,4	-	12,5	23,5	10	46	Tr440×5	321	452	728	6	G ¹ / ₈	8,5	12	0,36	1,89	2,81	1,84
420	4	552,8	-	12,5	23,5	8	25	Tr460×5	145	454,6	585,4	3	G ¹ / ₈	8,5	12	0,18	3,66	5,46	3,58
	6	589,3	-	12,5	23,5	11	35	Tr460×5	194	463	627	5	G ¹ / ₈	8,5	12	0,21	3,17	4,72	3,1
	6	576,7	-	12,5	23,5	22	30	Tr460×5	242	463	627	5	G ¹ / ₈	8,5	12	0,29	2,3	3,42	2,25
	6	630,2	-	12,5	23,5	11	42	Tr460×5	270	466	694	5	G ¹ / ₈	8,5	12	0,3	2,25	3,34	2,2
	6	614,3	614,2	12,5	23,5	22	30	Tr460×5	310	466	694	5	G ¹ / ₈	8,5	12	0,38	1,78	2,65	1,74
	7,5	670,7	-	12,5	23,5	11	48	Tr460×5	330	472	758	6	G ¹ / ₈	8,5	12	0,35	1,91	2,85	1,87
440	4	573,3	-	12,5	23,5	8	25	Tr480×5	145	474,6	605,4	3	G ¹ / ₈	8,5	12	0,18	3,85	5,73	3,76
	6	616,7	-	12,5	23,5	11	37	Tr480×5	202	483	657	5	G ¹ / ₈	8,5	12	0,21	3,17	4,72	3,1
	7,5	663,4	-	12,5	23,5	11	43	Tr480×5	285	492	728	6	G ¹ / ₈	8,5	12	0,31	2,21	3,29	2,16
	7,5	645,4	-	12,5	23,5	23	32	Tr480×5	332	492	728	6	G ¹ / ₈	8,5	12	0,38	1,76	2,62	1,72
	7,5	703,5	-	12,5	23,5	11	50	Tr480×5	349	492	798	6	G ¹ / ₈	8,5	12	0,36	1,9	2,83	1,86
460	5	598,8	-	12,5	23,5	9	28	Tr500×5	158	498	632	4	G ¹ / ₈	8,5	12	0,18	3,76	5,59	3,67
	6	636,9	-	12,5	23,5	12	38	Tr500×5	205	503	677	5	G ¹ / ₈	8,5	12	0,21	3,27	4,87	3,2
	6	626,1	-	12,5	23,5	23	32	Tr500×5	250	503	677	5	G ¹ / ₈	8,5	12	0,28	2,43	3,61	2,37
	7,5	690,4	-	12,5	23,5	12	45	Tr500×5	295	512	758	6	G ¹ / ₈	8,5	12	0,3	2,23	3,32	2,18
	7,5	673,14	-	12,5	23,5	25	35	Tr500×5	343	512	758	6	G ¹ / ₈	8,5	12	0,38	1,79	2,67	1,75
	7,5	737,1	-	12,5	23,5	12	52	Tr500×5	364	512	838	6	G ¹ / ₈	8,5	12	0,36	1,9	2,83	1,86
480	5	619,3	-	12,5	23,5	10	32	Tr520×6	162	518	652	4	G ¹ / ₈	8,5	12	0,17	3,9	5,81	3,81
	6	657,1	-	12,5	23,5	12	40	Tr540×6	209	523	697	5	G ¹ / ₈	8,5	12	0,21	3,24	4,82	3,16
	7,5	723,1	-	12,5	23,5	12	47	Tr550×6	313	532	798	6	G ¹ / ₈	8,5	12	0,31	2,2	3,27	2,15
	7,5	705,2	-	12,5	23,5	25	37	Tr520×6	362	532	798	6	G ¹ / ₈	8,5	12	0,38	1,78	2,65	1,74



Spherical roller bearings

With withdrawal sleeve

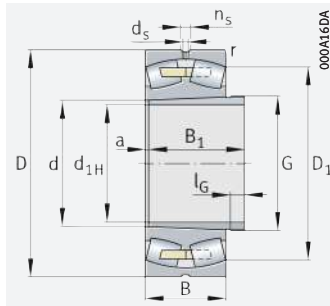

With solid cage, brass or steel

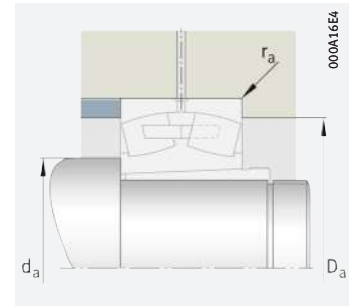

Mounting dimensions

$d_{1H} = 500 - 850$ mm

Main dimensions				Basic load ratings		Fatigue limit load	Limiting speed	Speed rating	Mass m		Designation		
d_{1H}	d	D	B	dyn. C_r	stat. C_{Or}				C_{ur}	n_G	$n_{\theta r}$	Bearing	Withdrawal sleeve
				kN	kN	N	min^{-1}	min^{-1}	≈ kg	≈ kg	Bearing	Withdrawal sleeve	X-life ▶ 671
500	530	710	136	2 850	6 900	385 000	930	500	146	43,1	239/530-K-MB	AH39/530-H	
	530	780	185	5 600	10 100	860 000	820	475	302	61,7	230/530-BEA-XL-K-MB1	AH30/530A-H	
	530	870	272	8 900	15 000	940 000	660	325	634	92,3	231/530-BEA-XL-K-MB1	AH31/530A-H	
	530	870	335	10 700	19 100	1 260 000	560	190	778	88,2	241/530-BEA-XL-K30-MB1	AH241/530-H	
530	560	750	140	3 100	7 600	520 000	880	465	176	47	239/560-B-K-MB	AH39/560-H	
	560	820	195	6 100	11 200	930 000	760	440	350	68,4	230/560-BEA-XL-K-MB1	AH30/560A-H	
	560	920	280	9 700	16 400	1 030 000	630	300	731	101	231/560-BEA-XL-K-MB1	AH31/560A-H	
	560	920	355	12 000	21 000	1 410 000	530	177	914	101	241/560-BEA-XL-K30-MB1	AH241/560-H	
570	600	800	150	3 450	8 600	630 000	810	430	210	55,6	239/600-B-K-MB	AH39/600-H	
	600	870	200	6 600	12 300	1 020 000	710	405	398	75	230/600-BEA-XL-K-MB1	AH30/600A-H	
	600	980	300	9 000	19 200	810 000	560	270	901	116	231/600-K-MB	AH31/600A-H	
	600	980	375	11 600	26 000	1 780 000	480	149	1 170	118	241/600-B-K30-MB	AH241/600-H	
600	630	850	165	4 100	9 900	710 000	740	405	283	64,5	239/630-B-K-MB	AH39/630-H	
	630	920	212	7 400	13 700	1 120 000	670	380	476	87,3	230/630-BEA-XL-K-MB1	AH30/630A-H	
	630	920	290	9 400	18 600	1 370 000	550	265	645	95,1	240/630-BEA-XL-K30-MB1	AH240/630-H	
	630	1 030	400	13 100	29 500	1 990 000	440	136	1 360	132	241/630-B-K30-MB	AH241/630-H	
630	670	900	170	4 300	10 600	750 000	710	375	310	87,7	239/670-B-K-MB	AH39/670-H	
	670	980	230	7 200	15 800	1 100 000	630	350	590	124	230/670-B-K-MB	AH30/670A-H	
	670	1 090	412	14 000	31 500	2 110 000	420	127	1 539	183	241/670-B-K30-MB	AH241/670-H	
670	710	950	180	4 800	12 100	720 000	670	350	336	101	239/710-K-MB	AH39/710-H	
	710	1 030	236	7 600	16 900	1 150 000	590	325	650	135	230/710-B-K-MB	AH30/710A-H	
	710	1 030	315	9 600	23 000	1 560 000	480	223	873	151	240/710-B-K30-MB	AH240/710-H	
	710	1 150	438	15 600	35 500	2 290 000	395	116	1 791	209	241/710-B-K30-MB	AH241/710-H	
710	750	1 000	185	5 200	13 000	790 000	640	325	394	110	239/750-K-MB	AH39/750-H	
	750	1 090	250	8 500	19 100	1 010 000	550	305	786	155	230/750-K-MB	AH30/750A-H	
	750	1 090	335	10 800	26 000	1 740 000	445	204	1 071	169	240/750-B-K30-MB	AH240/750-H	
750	800	1 060	195	5 900	15 100	1 010 000	580	295	490	146	239/800-B-K-MB	AH39/800-H	
	800	1 150	258	9 300	21 200	1 420 000	530	280	877	198	230/800-K-MB	AH30/800A-H	
800	850	1 120	200	6 300	16 400	960 000	550	275	554	165	239/850-K-MB	AH39/850-H	
	850	1 220	365	12 800	32 000	2 060 000	390	173	1 415	250	240/850-B-K30-MB	AH240/850-H	
850	900	1 180	206	6 500	17 200	1 010 000	520	260	641	180	239/900-K-MB	AH39/900-H	

medias ▶ <https://www.schaeffler.de/std/1EF6>

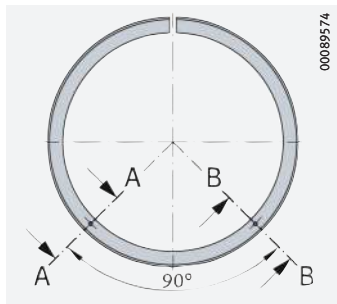

Pump connectors for hydraulic withdrawal sleeve

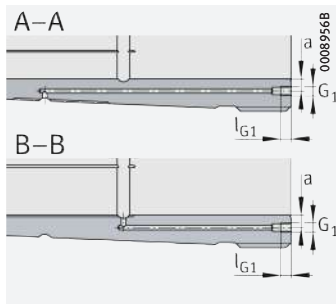

Hydraulic withdrawal sleeve (...H)
Mounting dimensions

Dimensions										Mounting dimensions						Calculation factors			
d_{1H}	r	D_1	d_s	n_s	a	l_G	Thread G	B_1		d_a	D_a	r_a	G_1	a	l_{G1}	e	Y_1	Y_2	Y_0
	min.	≈			≈					min.	max.	max.							
500	5	656,5	12,5	23,5	10	37	Tr550×6	175	548	692	4	$G^{1/4}$	10	15	0,18	3,85	5,73	3,76	
	6	708,2	12,5	23,5	12	45	Tr560×6	230	553	757	5	$G^{1/4}$	10	15	0,22	3,1	4,62	3,03	
	7,5	760,5	12,5	23,5	12	53	Tr560×6	325	562	838	6	$G^{1/4}$	10	15	0,3	2,25	3,34	2,2	
	7,5	742,9	12,5	23,5	25	40	Tr550×6	375	562	838	6	$G^{1/4}$	10	15	0,37	1,83	2,72	1,79	
530	5	693,4	12,5	23,5	10	37	Tr580×6	180	578	732	4	$G^{1/4}$	12	15	0,17	3,95	5,88	3,86	
	6	745	12,5	23,5	12	45	Tr590×6	240	583	797	5	$G^{1/4}$	12	15	0,22	3,1	4,62	3,03	
	7,5	806,6	12,5	23,5	12	55	Tr590×6	335	592	888	6	$G^{1/4}$	12	15	0,29	2,32	3,45	2,26	
	7,5	791,5	12,5	23,5	28	45	Tr580×6	400	592	888	6	$G^{1/4}$	12	15	0,37	1,83	2,72	1,79	
570	5	740,5	12,5	23,5	10	38	Tr625×6	192	618	782	4	$G^{1/4}$	12	15	0,17	3,95	5,88	3,86	
	6	793,3	12,5	23,5	14	45	Tr630×6	245	623	847	5	$G^{1/4}$	12	15	0,21	3,24	4,82	3,16	
	7,5	852,6	12,5	23,5	14	55	Tr630×6	355	632	948	6	$G^{1/4}$	12	15	0,31	2,2	3,27	2,15	
	7,5	833	12,5	23,5	30	50	Tr625×6	425	632	948	6	$G^{1/4}$	12	15	0,38	1,79	2,67	1,75	
600	6	784,5	12,5	23,5	12	40	Tr655×6	210	653	827	5	$G^{1/4}$	12	15	0,18	3,8	5,66	3,72	
	7,5	837,8	12,5	23,5	14	46	Tr670×6	258	658	892	6	$G^{1/4}$	12	15	0,21	3,24	4,82	3,16	
	7,5	821,5	12,5	23,5	30	45	Tr655×6	335	658	892	6	$G^{1/4}$	12	15	0,28	2,39	3,56	2,34	
	7,5	872,2	12,5	23,5	30	50	Tr655×6	450	662	998	6	$G^{1/4}$	12	15	0,38	1,78	2,65	1,74	
630	6	831,5	12,5	23,5	12	41	Tr695×6	216	693	877	5	$G^{1/4}$	12	15	0,17	3,95	5,88	3,86	
	7,5	888,7	12,5	23,5	14	50	Tr710×7	280	698	952	6	$G^{1/4}$	12	15	0,22	3,01	4,48	2,94	
	7,5	929,4	12,5	23,5	30	55	Tr695×6	467	702	1058	6	$G^{1/4}$	12	15	0,37	1,83	2,72	1,79	
670	6	877,5	12,5	23,5	12	43	Tr740×7	228	733	927	5	$G^{1/4}$	15	15	0,18	3,85	5,73	3,76	
	7,5	938,8	12,5	23,5	16	50	Tr750×7	286	738	1002	6	$G^{1/4}$	15	15	0,22	3,07	4,57	3	
	7,5	921,6	12,5	23,5	33	50	Tr740×7	365	738	1002	6	$G^{1/4}$	15	15	0,3	2,26	3,37	2,21	
	9,5	980,2	12,5	23,5	33	55	Tr740×7	493	750	1110	8	$G^{1/4}$	15	15	0,38	1,79	2,67	1,75	
710	6	923,2	12,5	23,5	12	44	Tr780×7	234	773	977	5	$G^{1/4}$	15	15	0,17	3,95	5,88	3,86	
	7,5	990,9	12,5	23,5	16	50	Tr800×7	300	778	1062	6	$G^{1/4}$	15	15	0,22	3,01	4,48	2,94	
	7,5	976,2	12,5	23,5	35	50	Tr780×7	385	778	1062	6	$G^{1/4}$	15	15	0,3	2,26	3,37	2,21	
750	6	983,7	12,5	23,5	12	45	Tr830×7	245	823	1037	5	$G^{1/4}$	15	15	0,17	4,05	6,04	3,96	
	7,5	1050,9	12,5	23,5	18	50	Tr850×7	308	828	1122	6	$G^{1/4}$	15	15	0,22	3,07	4,57	3	
800	6	1039,9	12,5	23,5	12	50	Tr880×7	258	873	1097	5	$G^{1/4}$	15	15	0,16	4,11	6,12	4,02	
	7,5	1092,9	12,5	23,5	40	53	Tr880×7	418	878	1192	6	$G^{1/4}$	15	15	0,29	2,33	3,47	2,28	
850	6	1098,8	12,5	23,5	12	51	Tr930×8	265	923	1157	5	$G^{1/4}$	15	15	0,16	4,28	6,37	4,19	





Spherical roller bearings

For vibratory machinery
Cylindrical or tapered bore

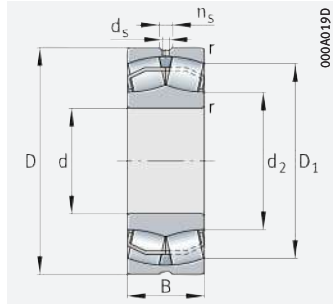

Cylindrical bore

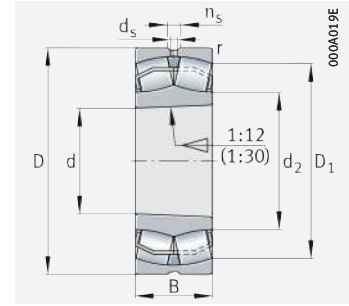

Tapered bore

d = 40 – 110 mm

Main dimensions			Basic load ratings		Fatigue limit load C_{ur} N	Limiting speed n_G min^{-1}	Speed rating $n_{\partial r}$ min^{-1}	Mass m \approx kg	Designation ▶ 681 1.12 ▶ 683 1.13 X-life ▶ 671
d	D	B	dyn. C_r kN	stat. C_{Or} kN					
40	90	33	156	149	13 100	7 600	5 500	1,05	22308-E1-XL-T41A
	90	33	156	149	13 100	7 600	5 500	1	22308-E1-XL-K-T41A
45	100	36	187	183	16 000	6 800	5 000	1,39	22309-E1-XL-T41A
	100	36	187	183	16 000	6 800	5 000	1,4	22309-E1-XL-K-T41A
50	110	40	229	223	20 100	6 300	4 800	1,9	22310-E1-XL-T41A
	110	40	229	223	20 100	6 300	4 800	1,9	22310-E1-XL-K-T41A
55	120	43	265	260	23 900	5 800	4 500	2,27	22311-E1-XL-T41A
	120	43	265	260	23 900	5 800	4 500	2,2	22311-E1-XL-K-T41A
60	130	46	310	310	28 000	5 400	4 200	2,97	22312-E1-XL-T41A
	130	46	310	310	28 000	5 400	4 200	2,8	22312-E1-XL-K-T41A
65	140	48	350	365	32 500	5 000	3 800	3,57	22313-E1-XL-T41A
	140	48	350	365	32 500	5 000	3 800	3,5	22313-E1-XL-K-T41A
70	150	51	390	390	36 500	4 800	3 700	4,21	22314-E1-XL-T41A
	150	51	390	390	36 500	4 800	3 700	4,1	22314-E1-XL-K-T41A
75	160	55	445	450	40 500	4 500	3 550	5,38	22315-E1-XL-T41A
	160	55	445	450	40 500	4 500	3 550	5,3	22315-E1-XL-K-T41A
80	170	58	495	510	45 000	4 250	3 400	6,27	22316-E1-XL-T41A
	170	58	495	510	45 000	4 250	3 400	6,1	22316-E1-XL-K-T41A
85	180	60	540	560	49 500	4 100	3 200	7,06	22317-E1-XL-T41D
	180	60	540	560	49 500	4 100	3 200	7,1	22317-E1-XL-K-T41A
90	190	64	610	630	55 000	3 850	3 000	8,69	22318-E1-XL-T41D
	190	64	610	630	55 000	3 850	3 000	8,5	22318-E1-XL-K-T41A
95	200	67	670	700	59 000	3 700	2 800	9,69	22319-E1-XL-T41D
	200	67	670	700	59 000	3 700	2 800	9,5	22319-E1-XL-K-T41A
100	215	82,6	680	900	69 000	2 800	–	15,5	23320-AS-MA-T41A
	215	73	810	920	75 000	3 300	2 380	13,1	22320-E1-XL-T41D
	215	73	810	920	75 000	3 300	2 380	13	22320-E1-XL-K-T41A
110	240	92,1	830	1 080	86 000	2 600	–	21,3	23322-AS-MA-T41A
	240	80	950	1 070	90 000	3 000	2 130	17,7	22322-E1-XL-T41D
	240	80	950	1 070	90 000	3 000	2 130	17,4	22322-E1-XL-K-T41A

medias ▶ <https://www.schaeffler.de/std/1EF7>

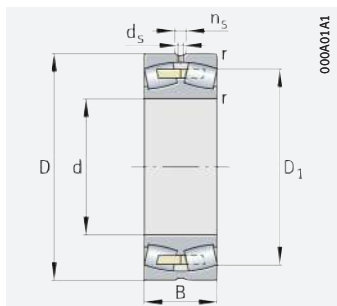

Solid cage, brass or steel;
cylindrical bore

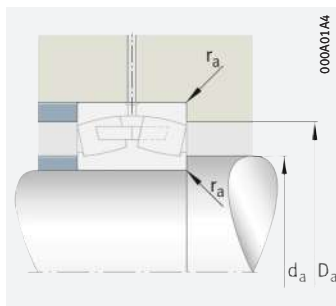

Mounting dimensions

Dimensions						Mounting dimensions			Calculation factors			
d	r	D ₁	d ₂	d _s	n _s	d _a	D _a	r _a	e	Y ₁	Y ₂	Y ₀
	min.	≈	≈			min.	max.	max.				
40	1,5	76	52,4	3,2	6,5	49	81	1,5	0,36	1,86	2,77	1,82
	1,5	76	52,4	3,2	6,5	49	81	1,5	0,36	1,86	2,77	1,82
45	1,5	84,7	58,9	3,2	6,5	54	91	1,5	0,36	1,9	2,83	1,86
	1,5	84,7	58,9	3,2	6,5	54	91	1,5	0,36	1,9	2,83	1,86
50	2	92,6	63	3,2	6,5	61	99	2	0,36	1,86	2,77	1,82
	2	92,6	63	3,2	6,5	61	99	2	0,36	1,86	2,77	1,82
55	2	101,4	68,9	3,2	6,5	66	109	2	0,36	1,89	2,81	1,84
	2	101,4	68,9	3,2	6,5	66	109	2	0,36	1,89	2,81	1,84
60	2,1	110,1	74,8	3,2	6,5	72	118	2,1	0,35	1,91	2,85	1,87
	2,1	110,1	74,8	3,2	6,5	72	118	2,1	0,35	1,91	2,85	1,87
65	2,1	119,3	83,2	4,8	9,5	77	128	2,1	0,34	2	2,98	1,96
	2,1	119,3	83,2	4,8	9,5	77	128	2,1	0,34	2	2,98	1,96
70	2,1	128	86,7	4,8	9,5	82	138	2,1	0,34	2	2,98	1,96
	2,1	128	86,7	4,8	9,5	82	138	2,1	0,34	2	2,98	1,96
75	2,1	136,3	92,4	4,8	9,5	87	148	2,1	0,34	1,99	2,96	1,94
	2,1	136,3	92,4	4,8	9,5	87	148	2,1	0,34	1,99	2,96	1,94
80	2,1	145,1	98,3	4,8	9,5	92	158	2,1	0,34	1,99	2,96	1,94
	2,1	145,1	98,3	4,8	9,5	92	158	2,1	0,34	1,99	2,96	1,94
85	3	154,2	104,4	4,8	9,5	99	166	2,5	0,33	2,04	3,04	2
	3	154,2	104,4	4,8	9,5	99	166	2,5	0,33	2,04	3,04	2
90	3	162,5	110,2	6,3	12,2	104	176	2,5	0,33	2,03	3,02	1,98
	3	162,5	110,2	6,3	12,2	104	176	2,5	0,33	2,03	3,02	1,98
95	3	171,2	116	6,3	12,2	109	186	2,5	0,33	2,03	3,02	1,98
	3	171,2	116	6,3	12,2	109	186	2,5	0,33	2,03	3,02	1,98
100	3	179,5	–	4,8	9,5	114	201	2,5	0,43	1,57	2,34	1,53
	3	184,7	130,2	6,3	12,2	114	201	2,5	0,33	2,03	3,02	1,98
	3	184,7	130,2	6,3	12,2	114	201	2,5	0,33	2,03	3,02	1,98
110	3	199,6	–	6,3	12,2	124	226	2,5	0,43	1,57	2,34	1,53
	3	204,9	143,1	8	15	124	226	2,5	0,33	2,07	3,09	2,03
	3	204,9	143,1	8	15	124	226	2,5	0,33	2,07	3,09	2,03





Spherical roller bearings

For vibratory machinery
Cylindrical or tapered bore

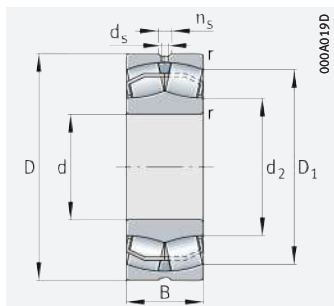

Cylindrical bore

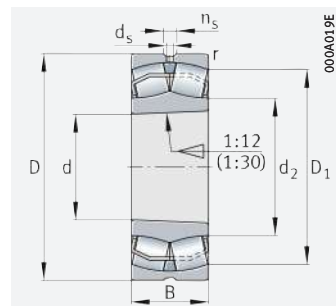

Tapered bore

d = 120 – 220 mm

Main dimensions			Basic load ratings		Fatigue limit load	Limiting speed	Speed rating	Mass	Designation
d	D	B	dyn. C _r	stat. C _{0r}	C _{ur}	n _G	n _{0r}	m	▶ 681 1.12 ▶ 683 1.13 X-life ▶ 671
			kN	kN	N	min ⁻¹	min ⁻¹	≈ kg	
120	260	106	1 020	1 430	103 000	2 400	–	29,1	23324-AS-MA-T41A
	260	86	1 080	1 170	102 000	2 850	2 000	22,3	22324-E1-XL-T41D
	260	86	1 080	1 170	102 000	2 850	2 000	22,1	22324-E1-XL-K-T41A
130	280	112	1 160	1 600	108 000	2 200	–	34,2	23326-AS-MA-T41A
	280	93	1 250	1 370	116 000	2 650	1 820	28	22326-E1-XL-T41D
	280	93	1 250	1 370	116 000	2 650	1 820	27,4	22326-E1-XL-K-T41A
140	300	118	1 270	1 800	123 000	2 000	–	40,9	23328-AS-MA-T41A
	300	102	1 460	1 630	131 000	2 420	1 660	34,6	22328-E1-XL-T41D
	300	102	1 460	1 630	131 000	2 420	1 660	34,4	22328-E1-XL-K-T41A
150	320	128	1 500	2 120	135 000	2 000	–	49,8	23330-A-MA-T41A
	320	108	1 640	1 850	147 000	2 290	1 520	42,2	22330-E1-XL-T41D
	320	108	1 640	1 850	147 000	2 290	1 520	40,9	22330-E1-XL-K-T41A
160	340	136	1 660	2 320	152 000	2 000	–	61,3	23332-A-MA-T41A
	340	114	1 680	1 990	157 000	2 250	1 420	47,3	22332-BE-XL-K-JPA-T41A
	340	114	1 680	1 990	157 000	2 250	1 420	48,4	22332-BE-XL-K-JPA-T41A
170	360	120	1 870	2 220	173 000	2 130	1 320	56,9	22334-BE-XL-K-JPA-T41A
	360	120	1 870	2 220	173 000	2 130	1 320	58,2	22334-BE-XL-K-JPA-T41A
180	380	126	2 060	2 460	190 000	2 030	1 230	66,6	22336-BE-XL-K-JPA-T41A
	380	126	2 060	2 460	190 000	2 030	1 230	68,1	22336-BE-XL-K-JPA-T41A
190	400	155	2 200	3 200	223 000	1 400	–	97,1	23338-A-MA-T41A
	400	132	2 220	2 650	207 000	1 940	1 160	77,2	22338-BE-XL-K-JPA-T41A
	400	132	2 220	2 650	207 000	1 940	1 160	78,9	22338-BE-XL-K-JPA-T41A
200	420	165	2 450	3 600	238 000	1 300	–	108	23340-A-MA-T41A
	420	138	2 440	2 950	225 000	1 830	1 080	87,4	22340-BE-XL-K-JPA-T41A
	420	138	2 440	2 950	225 000	1 830	1 080	89,4	22340-BE-XL-K-JPA-T41A
220	460	145	2 800	3 400	265 000	1 690	950	114	22344-BE-XL-K-JPA-T41A
	460	145	2 800	3 400	265 000	1 690	950	117	22344-BE-XL-K-JPA-T41A

medias ▶ <https://www.schaeffler.de/std/1EF8>

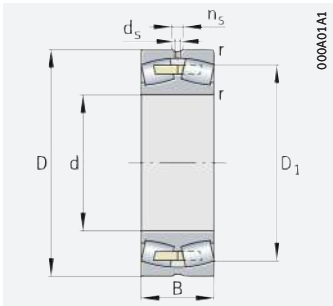

Solid cage, brass or steel;
cylindrical bore

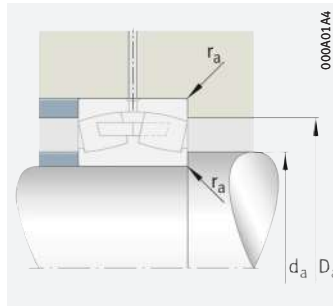

Mounting dimensions

Dimensions						Mounting dimensions			Calculation factors			
d	r	D ₁	d ₂	d _s	n _s	d _a	D _a	r _a	e	Y ₁	Y ₂	Y ₀
	min.	≈	≈			min.	max.	max.				
120	3	213,9	–	6,3	12,2	134	246	2,5	0,45	1,5	2,23	1,46
	3	222,4	150,8	8	15	134	246	2,5	0,33	2,06	3,06	2,01
	3	222,4	150,7	8	15	134	246	2,5	0,33	2,06	3,06	2,01
130	4	232,1	–	6,3	12,2	147	263	3	0,45	1,51	2,25	1,48
	4	239,5	162,2	9,5	17,7	147	263	3	0,33	2,06	3,06	2,01
	4	239,5	162,2	9,5	17,7	147	263	3	0,33	2,06	3,06	2,01
140	4	249,2	–	6,3	12,2	157	283	3	0,43	1,57	2,34	1,53
	4	255,7	173,5	9,5	17,7	157	283	3	0,34	2	2,98	1,96
	4	255,7	173,5	9,5	17,7	157	283	3	0,34	2	2,98	1,96
150	4	264,5	–	8	15	167	303	3	0,44	1,52	2,26	1,49
	4	273,2	185,3	9,5	17,7	167	303	3	0,33	2,02	3	1,97
	4	273,2	185,3	9,5	17,7	167	303	3	0,33	2,02	3	1,97
160	4	280,6	–	9,5	17,7	177	323	3	0,44	1,54	2,3	1,51
	4	286,7	201,2	9,5	17,7	177	323	3	0,35	1,94	2,88	1,89
	4	286,7	201,2	9,5	17,7	177	323	3	0,35	1,94	2,88	1,89
170	4	303,9	213,1	9,5	17,7	187	343	3	0,35	1,95	2,9	1,91
	4	303,9	213,1	9,5	17,7	187	343	3	0,35	1,95	2,9	1,91
180	4	320,8	224,9	12,5	23,5	197	363	3	0,34	1,96	2,92	1,92
	4	320,8	224,9	12,5	23,5	197	363	3	0,34	1,96	2,92	1,92
190	5	331,6	–	9,5	17,7	210	380	4	0,43	1,57	2,34	1,53
	5	338,1	236,8	12,5	23,5	210	380	4	0,34	1,96	2,92	1,92
	5	338,1	236,8	12,5	23,5	210	380	4	0,34	1,96	2,92	1,92
200	5	350,2	–	9,5	17,7	220	400	4	0,43	1,55	2,31	1,52
	5	355,1	248,8	12,5	23,5	220	400	4	0,34	1,98	2,94	1,93
	5	355,1	248,8	12,5	23,5	220	400	4	0,34	1,98	2,94	1,93
220	5	391,1	273,4	12,5	23,5	240	440	4	0,33	2,06	3,06	2,01
	5	391,1	273,4	12,5	23,5	240	440	4	0,33	2,06	3,06	2,01





Spherical roller bearings

For vibratory machinery
With adapter sleeve

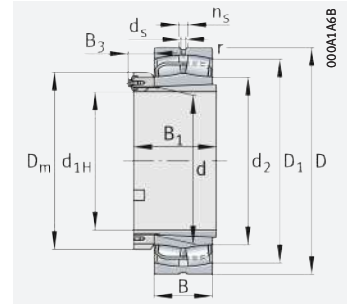
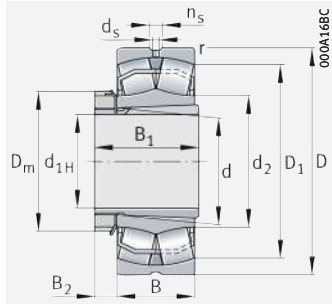

With locknut and retaining bracket

d_{1H} = 35 – 200 mm

Main dimensions				Basic load ratings		Fatigue limit load C _{ur} N	Limiting speed n _G min ⁻¹	Speed rating n _{thr} min ⁻¹	Mass m		Designation	
d _{1H}	d	D	B	dyn. C _r kN	stat. C _{0r} kN				Bearing ≈ kg	Adapter sleeve ≈ kg	▶ 681 1.12 ▶ 683 1.13 X-life ▶ 671	Bearing
35	40	90	33	156	149	13 100	7 600	5 500	1	0,23	22308-E1-XL-K-T41A	H2308
40	45	100	36	187	183	16 000	6 800	5 000	1,4	0,298	22309-E1-XL-K-T41A	H2309
45	50	110	40	229	223	20 100	6 300	4 800	1,9	0,36	22310-E1-XL-K-T41A	H2310
50	55	120	43	265	260	23 900	5 800	4 500	2,2	0,435	22311-E1-XL-K-T41A	H2311
55	60	130	46	310	310	28 000	5 400	4 200	2,8	0,493	22312-E1-XL-K-T41A	H2312
60	65	140	48	350	365	32 500	5 000	3 800	3,5	0,57	22313-E1-XL-K-T41A	H2313
	70	150	51	390	390	36 500	4 800	3 700	4,1	0,92	22314-E1-XL-K-T41A	H2314
65	75	160	55	445	450	40 500	4 500	3 550	5,3	1,06	22315-E1-XL-K-T41A	H2315
70	80	170	58	495	510	45 000	4 250	3 400	6,1	1,31	22316-E1-XL-K-T41A	H2316
75	85	180	60	540	560	49 500	4 100	3 200	7,1	1,47	22317-E1-XL-K-T41A	H2317
80	90	190	64	610	630	55 000	3 850	3 000	8,5	1,71	22318-E1-XL-K-T41A	H2318
85	95	200	67	670	700	59 000	3 700	2 800	9,5	1,95	22319-E1-XL-K-T41A	H2319
90	100	215	73	810	920	75 000	3 300	2 380	13	2,2	22320-E1-XL-K-T41A	H2320
100	110	240	80	950	1 070	90 000	3 000	2 130	17,4	2,78	22322-E1-XL-K-T41A	H2322
110	120	260	86	1 080	1 170	102 000	2 850	2 000	22,1	3,24	22324-E1-XL-K-T41A	H2324
115	130	280	93	1 250	1 370	116 000	2 650	1 820	27,4	4,69	22326-E1-XL-K-T41A	H2326
125	140	300	102	1 460	1 630	131 000	2 420	1 660	34,4	5,66	22328-E1-XL-K-T41A	H2328
135	150	320	108	1 640	1 850	147 000	2 290	1 520	40,9	6,76	22330-E1-XL-K-T41A	H2330
140	160	340	114	1 680	1 990	157 000	2 250	1 420	47,3	9,32	22332-BE-XL-K-JPA-T41A	H2332
150	170	360	120	1 870	2 220	173 000	2 130	1 320	56,9	10,4	22334-BE-XL-K-JPA-T41A	H2334
160	180	380	126	2 060	2 460	190 000	2 030	1 230	66,6	11,6	22336-BE-XL-K-JPA-T41A	H2336
170	190	400	132	2 220	2 650	207 000	1 940	1 160	77,2	12,9	22338-BE-XL-K-JPA-T41A	H2338
180	200	420	138	2 440	2 950	225 000	1 830	1 080	87,4	14,2	22340-BE-XL-K-JPA-T41A	H2340
200	220	460	145	2 800	3 400	265 000	1 690	950	114	17,8	22344-BE-XL-K-JPA-T41A	H2344X

medias ▶ <https://www.schaeffler.de/std/1EF9>

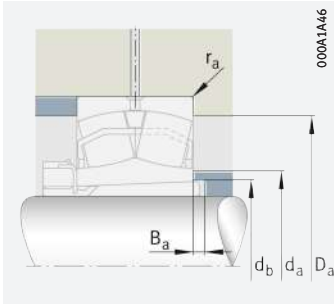

Mounting dimensions

Dimensions									Mounting dimensions					Calculation factors			
d_{1H}	r	D_1	d_2	d_s	n_s	D_m	B_1	B_2	d_a	D_a	d_b	B_a	r_a	e	Y_1	Y_2	Y_0
	min.	≈	≈					≈	max.	max.	min.	min.	max.				
35	1,5	76	52,4	3,2	6,5	58	46	10,25	49	81	45	5	1,5	0,36	1,86	2,77	1,82
40	1,5	84,7	58,9	3,2	6,5	65	50	11,25	54	91	50	5	1,5	0,36	1,9	2,83	1,86
45	2	92,6	63	3,2	6,5	70	55	12,25	61	99	56	5	2	0,36	1,86	2,77	1,82
50	2	101,4	68,9	3,2	6,5	75	59	12,5	66	109	61	6	2	0,36	1,89	2,81	1,84
55	2,1	110,1	74,8	3,2	6,5	80	62	12,5	72	118	66	5	2,1	0,35	1,91	2,85	1,87
60	2,1	119,3	83,2	4,8	9,5	85	65	13,5	77	128	72	5	2,1	0,34	2	2,98	1,96
	2,1	128	86,7	4,8	9,5	92	68	13,5	82	138	77	5	2,1	0,34	2	2,98	1,96
65	2,1	136,3	92,4	4,8	9,5	98	73	14,5	87	148	82	5	2,1	0,34	1,99	2,96	1,94
70	2,1	145,1	98,3	4,8	9,5	105	78	16,75	92	158	88	5	2,1	0,34	1,99	2,96	1,94
75	3	154,2	104,4	4,8	9,5	110	82	17,75	99	166	94	6	2,5	0,33	2,04	3,04	2
80	3	162,5	110,2	6,3	12,2	120	86	17,75	104	176	100	18	2,5	0,33	2,03	3,02	1,98
85	3	171,2	116	6,3	12,2	125	90	18,75	109	186	105	7	2,5	0,33	2,03	3,02	1,98
90	3	184,7	130,2	6,3	12,2	130	97	19,75	114	201	110	19	2,5	0,33	2,03	3,02	1,98
100	3	204,9	143,1	8	15	145	105	20,75	124	226	121	17	2,5	0,33	2,07	3,09	2,03
110	3	222,4	150,7	8	15	155	112	22	134	246	131	17	2,5	0,33	2,06	3,06	2,01
115	4	239,5	162,2	9,5	17,7	165	121	23	147	263	142	21	3	0,33	2,06	3,06	2,01
125	4	255,7	173,5	9,5	17,7	180	131	24	157	283	152	22	3	0,34	2	2,98	1,96
135	4	273,2	185,3	9,5	17,7	195	139	26	167	303	163	20	3	0,33	2,02	3	1,97
140	4	286,7	201,2	9,5	17,7	210	147	27,5	177	323	174	18	3	0,35	1,94	2,88	1,89
150	4	303,9	213,1	9,5	17,7	220	154	28,5	187	343	185	18	3	0,35	1,95	2,9	1,91
160	4	320,8	224,9	12,5	23,5	230	161	29,5	197	363	195	22	3	0,34	1,96	2,92	1,92
170	5	338,1	236,8	12,5	23,5	240	169	30,5	210	380	206	9	4	0,34	1,96	2,92	1,92
180	5	355,1	248,8	12,5	23,5	250	176	31,5	220	400	216	10	4	0,34	1,98	2,94	1,93
200	5	391,1	273,4	12,5	23,5	280	186	35	240	440	236	10	4	0,33	2,06	3,06	2,01



Spherical roller bearings

For vibratory machinery
With withdrawal sleeve

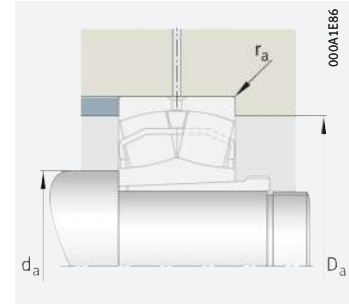
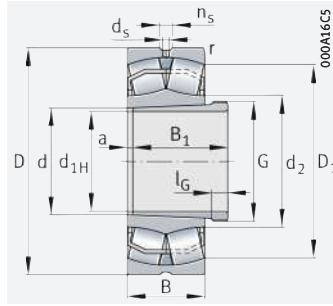

Mounting dimensions

$d_{1H} = 35 - 200 \text{ mm}$

Main dimensions				Basic load ratings		Fatigue limit load C_{ur} N	Limiting speed n_G min^{-1}	Speed rating n_{Dr} min^{-1}	Mass m		Designation	
d_{1H}	d	D	B	dyn. C_r kN	stat. C_{Or} kN				Bearing $\approx \text{kg}$	With- drawal sleeve $\approx \text{kg}$	Bearing	With- drawal sleeve
35	40	90	33	156	149	13 100	7 600	5 500	1	0,13	22308-E1-XL-K-T41A	AH2308
40	45	100	36	187	183	16 000	6 800	5 000	1,4	0,17	22309-E1-XL-K-T41A	AH2309
45	50	110	40	229	223	20 100	6 300	4 800	1,9	0,22	22310-E1-XL-K-T41A	AHX2310
50	55	120	43	265	260	23 900	5 800	4 500	2,2	0,26	22311-E1-XL-K-T41A	AHX2311
55	60	130	46	310	310	28 000	5 400	4 200	2,8	0,32	22312-E1-XL-K-T41A	AHX2312
60	65	140	48	350	365	32 500	5 000	3 800	3,5	0,36	22313-E1-XL-K-T41A	AH2313G
65	70	150	51	390	390	36 500	4 800	3 700	4,1	0,42	22314-E1-XL-K-T41A	AHX2314G
70	75	160	55	445	450	40 500	4 500	3 550	5,3	0,48	22315-E1-XL-K-T41A	AHX2315G
75	80	170	58	495	510	45 000	4 250	3 400	6,1	0,61	22316-E1-XL-K-T41A	AHX2316
80	85	180	60	540	560	49 500	4 100	3 200	7,1	0,68	22317-E1-XL-K-T41A	AHX2317
85	90	190	64	610	630	55 000	3 850	3 000	8,5	0,78	22318-E1-XL-K-T41A	AHX2318
90	95	200	67	670	700	59 000	3 700	2 800	9,5	0,91	22319-E1-XL-K-T41A	AHX2319
95	100	215	73	810	920	75 000	3 300	2 380	13	1,03	22320-E1-XL-K-T41A	AHX2320
105	110	240	80	950	1 070	90 000	3 000	2 130	17,4	1,26	22322-E1-XL-K-T41A	AHX2322G
115	120	260	86	1 080	1 170	102 000	2 850	2 000	22,1	1,5	22324-E1-XL-K-T41A	AHX2324G
125	130	280	93	1 250	1 370	116 000	2 650	1 820	27,4	1,84	22326-E1-XL-K-T41A	AHX2326G
135	140	300	102	1 460	1 630	131 000	2 420	1 660	34,4	2,21	22328-E1-XL-K-T41A	AHX2328G
145	150	320	108	1 640	1 850	147 000	2 290	1 520	40,9	2,64	22330-E1-XL-K-T41A	AHX2330G
150	160	340	114	1 680	1 990	157 000	2 250	1 420	47,3	4,26	22332-BE-XL-K-JPA-T41A	AH2332G
160	170	360	120	1 870	2 220	173 000	2 130	1 320	56,9	4,78	22334-BE-XL-K-JPA-T41A	AH2334G
170	180	380	126	2 060	2 460	190 000	2 030	1 230	66,6	5,42	22336-BE-XL-K-JPA-T41A	AH2336G
180	190	400	132	2 220	2 650	207 000	1 940	1 160	77,2	6,02	22338-BE-XL-K-JPA-T41A	AH2338G
190	200	420	138	2 440	2 950	225 000	1 830	1 080	87,4	7,64	22340-BE-XL-K-JPA-T41A	AH2340
200	220	460	145	2 800	3 400	265 000	1 690	950	114	13,6	22344-BE-XL-K-JPA-T41A	AH2344

medias ► <https://www.schaeffler.de/std/1EFA>



Dimensions										Mounting dimensions			Calculation factors			
d_{1H}	r	D_1	d_2	d_s	n_s	a	B_1	l_G	Thread G	d_a	D_a	r_a	e	Y_1	Y_2	Y_0
	min.	≈	≈			≈				min.	max.	max.				
35	1,5	76	52,4	3,2	6,5	3	7	40	M45×1,5	49	81	1,5	0,36	1,86	2,77	1,82
40	1,5	84,7	58,9	3,2	6,5	3	7	44	M50×1,5	54	91	1,5	0,36	1,9	2,83	1,86
45	2	92,6	63	3,2	6,5	3	9	50	M55×2	61	99	2	0,36	1,86	2,77	1,82
50	2	101,4	68,9	3,2	6,5	3	10	54	M60×2	66	109	2	0,36	1,89	2,81	1,84
55	2,1	110,1	74,8	3,2	6,5	3	11	58	M65×2	72	118	2,1	0,35	1,91	2,85	1,87
60	2,1	119,3	83,2	4,8	9,5	3	12	61	M70×2	77	128	2,1	0,34	2	2,98	1,96
65	2,1	128	86,7	4,8	9,5	4	12	64	M75×2	82	138	2,1	0,34	2	2,98	1,96
70	2,1	136,3	92,4	4,8	9,5	4	12	68	M80×2	87	148	2,1	0,34	1,99	2,96	1,94
75	2,1	145,1	98,3	4,8	9,5	4	12	71	M90×2	92	158	2,1	0,34	1,99	2,96	1,94
80	3	154,2	104,4	4,8	9,5	4	13	74	M95×2	99	166	2,5	0,33	2,04	3,04	2
85	3	162,5	110,2	6,3	12,2	4	14	79	M100×2	104	176	2,5	0,33	2,03	3,02	1,98
90	3	171,2	116	6,3	12,2	4	16	85	M105×2	109	186	2,5	0,33	2,03	3,02	1,98
95	3	184,7	130,2	6,3	12,2	4	16	90	M110×2	114	201	2,5	0,33	2,03	3,02	1,98
105	3	204,9	143,1	8	15	4	16	98	M120×2	124	226	2,5	0,33	2,07	3,09	2,03
115	3	222,4	150,7	8	15	4	17	105	M130×2	134	246	2,5	0,33	2,06	3,06	2,01
125	4	239,5	162,2	9,5	17,7	4	19	115	M140×2	147	263	3	0,33	2,06	3,06	2,01
135	4	255,7	173,5	9,5	17,7	5	20	125	M150×2	157	283	3	0,34	2	2,98	1,96
145	4	273,2	185,3	9,5	17,7	5	24	135	M160×3	167	303	3	0,33	2,02	3	1,97
150	4	286,7	201,2	9,5	17,7	6	24	140	M170×3	177	323	3	0,35	1,94	2,88	1,89
160	4	303,9	213,1	9,5	17,7	6	24	146	M180×3	187	343	3	0,35	1,95	2,9	1,91
170	4	320,8	224,9	12,5	23,5	6	26	154	M190×3	197	363	3	0,34	1,96	2,92	1,92
180	5	338,1	236,8	12,5	23,5	7	26	160	M200×3	210	380	4	0,34	1,96	2,92	1,92
190	5	355,1	248,8	12,5	23,5	7	30	170	Tr220×4	220	400	4	0,34	1,98	2,94	1,93
200	5	391,1	273,4	12,5	23,5	8	30	181	Tr240×4	240	440	4	0,33	2,06	3,06	2,01



Toroidal roller bearings



Matrix for bearing preselection 799

1	Toroidal roller bearings	800
1.1	Bearing design	800
1.2	Load carrying capacity	805
1.3	Compensation of angular misalignments	805
1.4	Lubrication	805
1.5	Sealing	805
1.6	Speeds	806

1.7	Noise	806	1.17	Mounting and dismounting	826
1.8	Temperature range	806	1.18	Legal notice regarding data freshness	830
1.9	Cages	806	1.19	Further information	831
1.10	Internal clearance	807	Product tables	832	
1.11	Dimensions, tolerances	808	 Toroidal roller bearings	832	
1.12	Suffixes	809			
1.13	Structure of bearing designation	809			
1.14	Dimensioning	810			
1.15	Minimum load	811			
1.16	Design of bearing arrangements	815			







Matrix for bearing preselection

The matrix gives an overview of the types and design features of toroidal roller bearings.

It can be used to make a preliminary assessment of whether a bearing is fundamentally suitable for the envisaged application.

The additional information provided in the product chapter (see column "detailed information") and in the Technical principles must, however, be observed in selection of the bearing.

Design features and suitability			Toroidal roller bearings		
			with cage	full complement roller set	detailed information
+++ extremely suitable ++ highly suitable + suitable (+) suitable with restrictions – not suitable/not applicable available ✓ available					800
Load carrying capacity	radial		+++	+++	805 1.2
	axial, one direction		–	–	805 1.2
	axial, both directions		–	–	805 1.2
	moments		–	–	805 1.2
Compensation of angular misalignments	static		+++	+++	805 1.3
	dynamic		++	++	805 1.3
Bearing design	cylindrical bore		✓	✓	800 1.1
	tapered bore		✓	✓	800 1.1
	separable		–	–	800 1.1
Lubrication	greased		–	–	805 1.4
Sealing	open		✓	✓	805 1.5
	non-contact		–	–	805 1.5
	contact		–	–	805 1.5
Operating temperature in °C		from to	–30 +200	–30 +200	806 1.8
Suitability for	high speeds		+	(+)	806 1.6
	high running accuracy		++	++	808 1.11 114
	low-noise running		+	+	806 1.7 27
	high rigidity		++	+++	54
	reduced friction		+	(+)	56
	length compensation within bearing		+++	+++	800 1.1 25
	non-locating bearing arrangement		+++	+++	139
	locating bearing arrangement		–	–	139
X-life bearings			✓	✓	804
Bearing bore d in mm		from to	70 900	60 220	832
Product tables		from page	832	832	



1 Toroidal roller bearings



Toroidal roller bearings:

- combine the angular adjustment facility of spherical roller bearings with the unconstrained axial displacement facility of cylindrical roller bearings in one bearing ▶800|1.1
- have a very high radial load carrying capacity (in the full complement design) ▶832|
- support radial loads only ▶805|1.2
- are used solely as non-locating bearings (compensate axial displacements of the shaft relative to the housing)
- compensate misalignments between the shaft and housing ▶800| 1, ▶805|1.3
- permit high speeds in spite of line contact ▶832|
- are available in numerous sizes and designs ▶832|
- result in particularly compact and economical bearing arrangements.

For an overview of other product-specific features, see the Matrix for bearing preselection ▶799.

1
Axial displacement facility and angular adjustment facility in one bearing

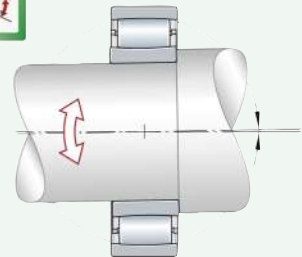
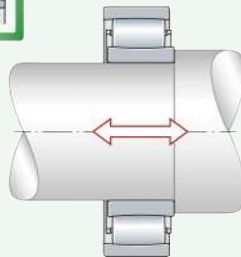

1.1 Bearing design

Design variants

Toroidal roller bearings are X-life bearings. The standard product range comprises:

- bearings with cage ▶801| 3
- full complement bearings ▶801| 3
- bearings with cylindrical or tapered bore (bearings with cage or full complement bearings) ▶802| 4.



The bearings described here constitute the basic product range of Schaeffler toroidal roller bearings. These bearings are, however, also available in many other designs and sizes, as well as for specific applications. Related information is available from Schaeffler on request.

Toroidal roller bearings

☞ Suitable for misalignments and where axial displacements of the shaft relative to the housing must be compensated without constraint in the bearing

Toroidal roller bearings are single row radial roller bearings with a low radial section height and very high load carrying capacity, which are part of the group of self-aligning bearings ➤801|☐2, ➤801|☐3 and ➤802|☐4. The outer ring has a toroidal raceway, which is concentric relative to the centre of the bearing. Correspondingly, the inner ring raceway is concave. This raceway design allows the bearings to compensate static and dynamic angular misalignments (skewing between the inner and outer ring) within certain limits ➤805|1.3 and ➤832|☐☐. The relatively long and slightly crowned symmetrical rollers have self-aligning characteristics (they are “self-guiding”); i.e. they will always automatically adopt the position at which the load is distributed uniformly over the length of the roller, irrespective of whether the bearing rings are displaced or skewed relative to each other ➤801|☐2.

As this “self-guiding” of the rollers improves the load distribution in the bearing, the bearing is able to run with less friction and, as a result, at lower temperatures. This in turn has a positive effect on the operating life of the bearing and lubricant.

☐2
Operating modes of the inner ring – with tilting and axial displacement

- ① Initial position
- ② Inner ring with tilting
- ③ Inner ring with axial displacement
- ④ Inner ring with displacement and tilting

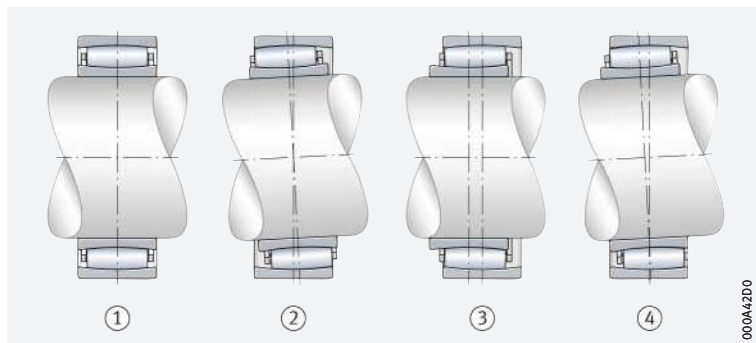

☞ With cage or full complement cylindrical roller set

☐3
Toroidal roller bearings with cage or full complement cylindrical roller set

F_r = radial load

- ① Bearing with solid brass cage
- ② Full complement design

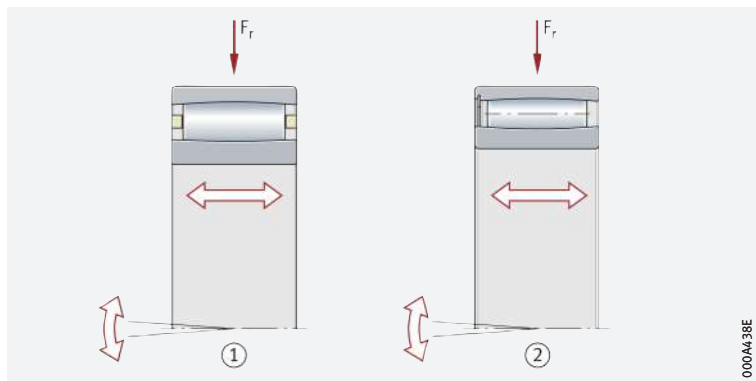

☞ The bore is cylindrical or tapered

With only a few exceptions, the bearings are available with a cylindrical bore as well as with a tapered bore ➤802|☐4. Bearings with a tapered bore have the bore taper 1:12 (suffix K) and 1:30 (suffix K30) ➤809|☐4 and ➤806|1.9.

4

Toroidal roller bearings
with cylindrical or tapered bore

F_r = radial load

- ① Bearing with cylindrical bore
- ② Bearing with tapered bore, taper angle 1:12

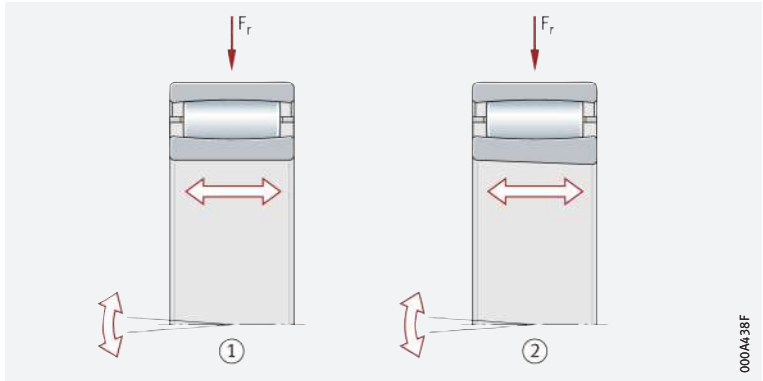

Roller profile design

The stress distribution at the contact points between the rollers and raceways is determined by the contact profile of the rollers. As a result, the roller profile is matched to the raceway profiles. In addition, the rollers exhibit high dimensional and geometrical accuracy. Consequently, the rollers in an individual rolling element set are practically identical in terms of their size and shape. This gives a favourable and even load distribution across all rollers and over the entire length of the roller, thus preventing edge stresses and stress peaks at the ends of the roller ➤ 802 | 5.

5

Uniform load distribution
due to optimised roller profile

F_r = radial load

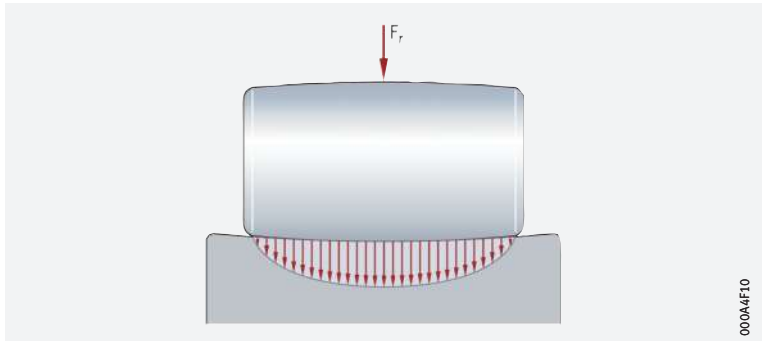

Length compensation
takes place without constraint
in the bearing

Bearings with non-locating bearing function

Toroidal roller bearings simplify the design of locating/non-locating bearing arrangements, as they compensate temperature-induced changes in length and skewing between the inner and outer ring with hardly any friction in the bearing ➤ 803 | 6. Axial displacements of the shaft relative to the housing are possible in both directions and within certain limits. Even more considerable axial displacements have no effect on the locating bearing. Length compensation takes place during rotary motion. The constraining forces occurring are so slight that they can be disregarded during operation. The maximum axial displacement distance s_1 and s_2 is given in the product tables ➤ 832 | 7. s_1 is valid for bearings with cages, s_1 and s_2 are valid for full complement bearings.

6

Locating/non-locating bearing arrangement, angular adjustment facility and axial displacement facility

- ① Spherical roller bearing (locating bearing)
- ② Toroidal roller bearing (non-locating bearing)

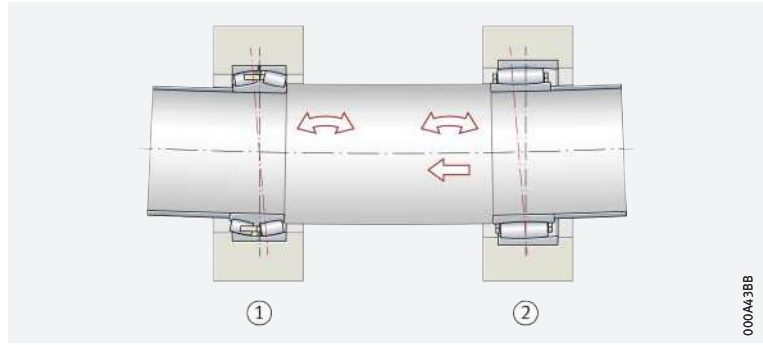

000A43BB

Product range

The range of toroidal roller bearings comprises eight series ►803|7.

7

Product range – cross-sectional comparison of available series

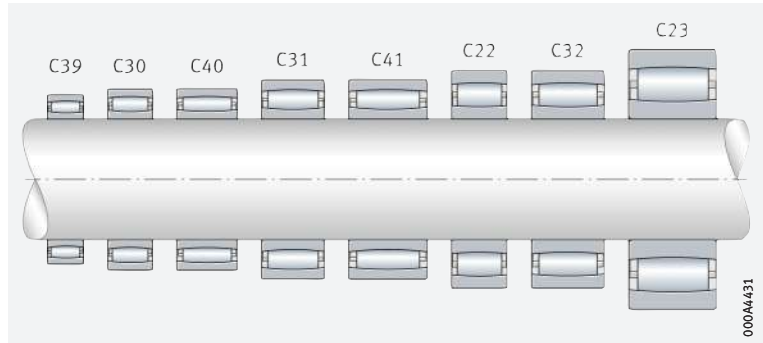

000A4431

Interchangeable with spherical roller bearings and cylindrical roller bearings

Substituting bearing arrangements composed of two spherical roller bearings for one spherical roller bearing (locating bearing) and one toroidal roller bearing (non-locating bearing) can significantly reduce the overall operating costs of the locating/non-locating system ►803|6 and ►803|8. The interchangeability of the bearings is ensured, as toroidal roller bearings are manufactured as standard in the same ISO dimension series and sizes as spherical roller bearings.

8

Comparison of the overall operating costs of locating/non-locating bearing systems

- ① Bearing arrangement with two spherical roller bearings
- ② Bearing arrangement with one spherical roller bearing (locating bearing) and one toroidal roller bearing (non-locating bearing)

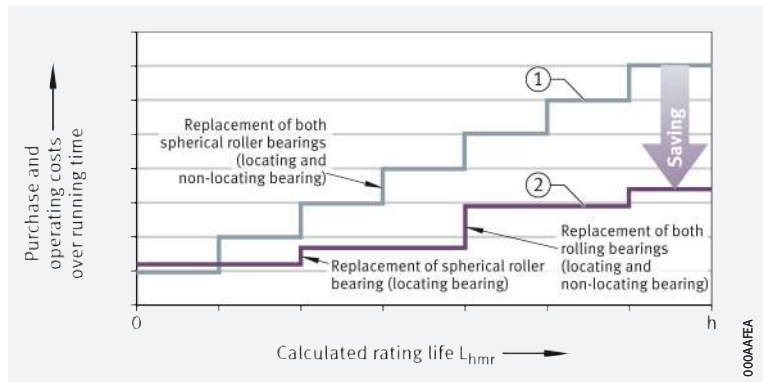

000A44EA





X-life premium quality

The toroidal roller bearings described here are X-life bearings. These products exhibit considerably higher performance than toroidal roller bearings that are not X-life. This is achieved, for example, through the optimised contact geometry between the rollers and raceways, as well as through the higher quality of the steel and rolling elements, higher surface quality and appropriate heat treatment.

Advantages

Increased customer benefits due to X-life

The technical enhancements offer a range of advantages, such as:

- a more favourable load distribution in the bearing and thus a higher dynamic load carrying capacity of the bearings (higher basic dynamic load ratings C_r)
- quieter running and higher running accuracy
- running with reduced friction and greater energy efficiency
- lower heat generation in the bearing
- higher possible speeds
- lower lubricant consumption and, consequently, longer maintenance intervals
- significantly reduced maintenance requirements
- a measurably longer operating life ► 803| 8
- high operational security
- compact, environmentally-friendly bearing arrangements.

Lower operating costs, higher machine availability

In conclusion, these advantages improve the overall cost-efficiency of the bearing position significantly and thus bring about a sustainable increase in the efficiency of the machine and equipment.

Suffix XL

X-life toroidal roller bearings include the suffix XL in the designation ► 800| 1.1 and ► 832| .

Areas of application

Wide application range

Due to their special technical features, X-life toroidal roller bearings are highly suitable for bearing arrangements in:



- paper machinery
- marine propulsion systems
- continuous casting plant
- steelworks and rolling mills
- ventilators, fans and pumps
- conveying equipment and belt installations
- crushers
- gearboxes
- agricultural machinery.



X-life indicates a high product performance density and thus a particularly significant benefit to the customer. Further information on X-life ► 10.

1.2 Load carrying capacity

 *The bearings are radial bearings*

Toroidal roller bearings support very high radial forces due to the line contact of the rollers. They may, however, only be subjected to purely radial load ►801| 3, ►802| 4 and ►800|1.1. As non-locating bearings, they cannot guide the shaft axially in either direction. Combining toroidal roller bearings with a spherical roller bearing on the locating bearing side results in bearing arrangements with a smaller design envelope, a lower mass and only low maintenance requirements ►803| 6.

 *Full complement bearings have the highest load carrying capacity*

Bearings without a cage can accommodate the largest possible number of rolling elements. As a result, the radial load carrying capacity of full complement toroidal roller bearings is higher still than for the designs with a cage. These bearings are therefore highly suitable for bearing arrangements in continuous casting plant.

1.3 Compensation of angular misalignments

 *Toroidal roller bearings compensate angular misalignments*

Toroidal roller bearings can be tilted by an angle of up to $0,5^\circ$ between the centre axes of the inner ring and outer ring without impairing the function and rating life. This allows the toroidal roller bearing to easily compensate a slight geometrical deviation of the housing bore or a shaft that is not precisely aligned.



Depending on the series and size, skewing of more than $0,5^\circ$ is possible, but may be associated with a reduction in the rating life. In the case of such applications, please contact our technical advisory service in order to achieve an optimum design of the bearing arrangement.

 *Roller offset under skewing*

Skewing of the bearing rings relative to each other causes a degree of roller offset in the bearing, which can cause the rollers to protrude beyond the rings. In order to prevent this, the axial displacement facility of the rings relative to each other is restricted ►822.



If there is any uncertainty regarding possible skewing in a specific application, please consult Schaeffler.

1.4 Lubrication

 *Oil or grease lubrication is possible*

Open toroidal roller bearings are not greased. They must be lubricated with oil or grease. Lubricant is introduced from one side and exits on the opposing side.



If there is any uncertainty regarding the suitability of the selected lubricant for the application, please consult Schaeffler or the lubricant manufacturer.



1.5 Sealing

 *Provide seals in the adjacent construction*

The bearings are not sealed; i.e. sealing of the bearing position must be carried out in the adjacent construction. This must reliably prevent:

- moisture and contaminants from entering the bearing
- the egress of lubricant from the bearing.

1.6 Speeds

Limiting speeds and reference speeds in the product tables

The product tables give two speeds for most bearings ▶832|:

- the kinematic limiting speed n_G
- the thermal speed rating $n_{\vartheta r}$.

Limiting speeds



The limiting speed n_G is the kinematically permissible speed of the bearing. Even under favourable mounting and operating conditions, this value should not be exceeded without prior consultation with Schaeffler ▶64.

Reference speeds

$n_{\vartheta r}$ is used to calculate n_{ϑ}

The thermal speed rating $n_{\vartheta r}$ is not an application-oriented speed limit, but is a calculated ancillary value for determining the thermally safe operating speed n_{ϑ} ▶64.

1.7 Noise

Schaeffler Noise Index

The Schaeffler Noise Index (SGI) is not yet available for this bearing type ▶69. The data for these bearing series will be introduced and updated in stages.

Further information:

- **medias** ▶ <https://medias.schaeffler.com>.

1.8 Temperature range

Limiting values

The operating temperature of the bearings is limited by:

- the dimensional stability of the bearing rings and rollers
- the cage
- the lubricant.

Toroidal roller bearings are dimensionally stable up to +200 °C. Possible operating temperatures of bearings ▶806| 1.

 **1**
Permissible temperature ranges

Operating temperature	Toroidal roller bearings	
	with cage	full complement roller set
	-30 °C to +200 °C	-30 °C to +200 °C



In the event of anticipated temperatures which lie outside the stated values, please contact Schaeffler.

1.9 Cages

Sheet steel and brass cages are used as standard



Depending on the series and bearing size, toroidal roller bearings are supplied with the following cages ▶809| 4:

- roller-guided sheet steel cage, single-piece (no suffix)
- roller-guided brass window cage (suffix M)
- brass window cage, guided on inner ring (suffix M1B).



1.10 Internal clearance

 The standard is CN



Radial internal clearance

Toroidal roller bearings are manufactured as standard with radial internal clearance CN (normal). CN is not stated in the designation. Values for bearings with a cylindrical bore $\blacktriangleright 807$  2, values for bearings with a tapered bore $\blacktriangleright 808$  3.





Toroidal roller bearings are also available with the smaller internal clearance C2 and with the larger internal clearance C3, C4 and C5 $\blacktriangleright 807$  2 and $\blacktriangleright 808$  3.



The values for radial internal clearance correspond to ISO 5753-1:2009 $\blacktriangleright 807$  2 and $\blacktriangleright 808$  3. They are valid for unmounted bearings which are free from load and measurement forces (without elastic deformation).



Axial displacements of the bearing rings relative to each other will reduce the internal clearance of toroidal roller bearings. This reduction can be determined by way of calculation $\blacktriangleright 821$  13.

 2
Radial internal clearance
of toroidal roller bearings
with cylindrical bore

Nominal bore diameter d mm		Radial internal clearance									
		C2 (Group 2)		CN (Group N)		C3 (Group 3)		C4 (Group 4)		C5 (Group 5)	
over	incl.	μm		μm		μm		μm		μm	
		min.	max.	min.	max.	min.	max.	min.	max.	min.	max.
18	24	15	30	25	40	35	55	50	65	65	85
24	30	15	35	30	50	45	60	60	80	75	95
30	40	20	40	35	55	55	75	70	95	90	120
40	50	25	45	45	65	65	85	85	110	105	140
50	65	30	55	50	80	75	105	100	140	135	175
65	80	40	70	65	100	95	125	120	165	160	210
80	100	50	85	80	120	120	160	155	210	205	260
100	120	60	100	100	145	140	190	185	245	240	310
120	140	75	120	115	170	165	215	215	280	280	350
140	160	85	140	135	195	195	250	250	325	320	400
160	180	95	155	150	220	215	280	280	365	360	450
180	200	105	175	170	240	235	310	305	395	390	495
200	225	115	190	185	265	260	340	335	435	430	545
225	250	125	205	200	285	280	370	365	480	475	605
250	280	135	225	220	310	305	410	405	520	515	655
280	315	150	240	235	330	330	435	430	570	570	715
315	355	160	260	255	360	360	485	480	620	620	790
355	400	175	280	280	395	395	530	525	675	675	850
400	450	190	310	305	435	435	580	575	745	745	930
450	500	205	335	335	475	475	635	630	815	810	1015
500	560	220	360	360	520	510	690	680	890	890	1110
560	630	240	400	390	570	560	760	750	980	970	1220
630	710	260	440	430	620	610	840	830	1080	1070	1340
710	800	300	500	490	680	680	920	920	1200	1200	1480
800	900	320	540	530	760	750	1020	1010	1330	1320	1660
900	1000	370	600	590	830	830	1120	1120	1460	1460	1830
1000	1120	410	660	660	930	930	1260	1260	1640	1640	2040
1120	1250	450	720	720	1020	1020	1380	1380	1800	1800	2240
1250	1400	490	800	800	1130	1130	1510	1540	1970	1970	2460
1400	1600	570	890	890	1250	1250	1680	1680	2200	2200	2740
1600	1800	650	1010	1010	1390	1390	1870	1870	2430	2430	3000



 **3**
Radial internal clearance
of toroidal roller bearings
with tapered bore

Nominal bore diameter d		Radial internal clearance									
		C2 (Group 2)		CN (Group N)		C3 (Group 3)		C4 (Group 4)		C5 (Group 5)	
mm		µm		µm		µm		µm		µm	
over	incl.	min.	max.	min.	max.	min.	max.	min.	max.	min.	max.
18	24	15	35	30	45	40	55	55	70	65	85
24	30	20	40	35	55	50	65	65	85	80	100
30	40	25	50	45	65	60	80	80	100	100	125
40	50	30	55	50	75	70	95	90	120	115	145
50	65	40	65	60	90	85	115	110	150	145	185
65	80	50	80	75	110	105	140	135	180	175	220
80	100	60	100	95	135	130	175	170	220	215	275
100	120	75	115	115	155	155	205	200	255	255	325
120	140	90	135	135	180	180	235	230	295	290	365
140	160	100	155	155	215	210	270	265	340	335	415
160	180	115	175	170	240	235	305	300	385	380	470
180	200	130	195	190	260	260	330	325	420	415	520
200	225	140	215	210	290	285	365	360	460	460	575
225	250	160	235	235	315	315	405	400	515	510	635
250	280	170	260	255	345	340	445	440	560	555	695
280	315	195	285	280	380	375	485	480	620	615	765
315	355	220	320	315	420	415	545	540	680	675	850
355	400	250	350	350	475	470	600	595	755	755	920
400	450	280	385	380	525	525	655	650	835	835	1005
450	500	305	435	435	575	575	735	730	915	910	1115
500	560	330	480	470	640	630	810	800	1010	1000	1230
560	630	380	530	530	710	700	890	880	1110	1110	1350
630	710	420	590	590	780	770	990	980	1230	1230	1490
710	800	480	680	670	860	860	1100	1100	1380	1380	1660
800	900	520	740	730	960	950	1220	1210	1530	1520	1860
900	1000	580	820	810	1040	1040	1340	1340	1670	1670	2050
1000	1120	640	900	890	1170	1160	1500	1490	1880	1870	2280
1120	1250	700	980	970	1280	1270	1640	1630	2060	2050	2500
1250	1400	770	1080	1080	1410	1410	1790	1780	2250	2250	2740
1400	1600	870	1200	1200	1550	1550	1990	1990	2500	2500	3050
1600	1800	950	1320	1320	1690	1690	2180	2180	2730	2730	3310

1.11 Dimensions, tolerances

Dimension standards



The main dimensions of toroidal roller bearings correspond to ISO 15:2017 (DIN 616:2000).

Chamfer dimensions



The limiting dimensions for chamfer dimensions correspond to DIN 620-6:2004. Overview and limiting values ►135|7.11.
Nominal value of chamfer dimension ►832|.

Tolerances



The dimensional tolerances of toroidal roller bearings with a cylindrical and tapered bore correspond to the tolerance class Normal in accordance with ISO 492:2014. Tolerance values in accordance with ISO 492 ►122| 8.

Running accuracy

The running accuracy of the inner and outer ring corresponds to tolerance class 5 in accordance with ISO 492:2014. Tolerance values in accordance with ISO 492 ►126| 14.

1.12 Suffixes

For a description of the suffixes used in this chapter ▶ 809| 4 and **medias** interchange ▶ <https://www.schaeffler.de/std/1D52>.

4
Suffixes and corresponding descriptions

Suffix	Description of suffix	
C2	Radial internal clearance C2 (smaller than normal)	Available by agreement
C3	Radial internal clearance C3 (larger than normal)	
C4	Radial internal clearance C4 (larger than C3)	
C5	Radial internal clearance C5 (larger than C4)	
K	Tapered bore, taper 1:12	Standard
K30	Tapered bore, taper 1:30	
M	Brass window cage, guided by rollers	
M1B	Brass window cage, guided on inner ring	
V	Full complement	
W209B	Inner ring made from case hardening steel	
XL	X-life bearing	

1.13 Structure of bearing designation

Examples of composition of bearing designation

The designation of bearings follows a set model. Examples ▶ 809| 9 and ▶ 809| 10. The composition of designations is subject to DIN 623-1 ▶ 102| 10.

9
Toroidal roller bearing, series 31, with cage, tapered bore: designation structure

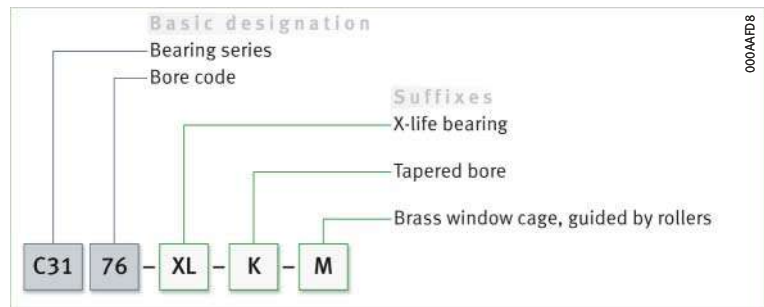

10
Toroidal roller bearing, series 40, full complement, cylindrical bore: designation structure

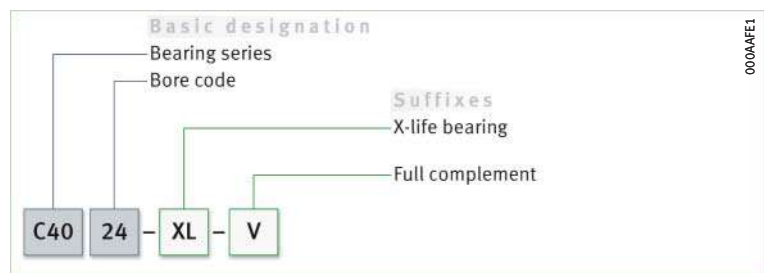

1.14 Dimensioning

$P = F_r$ under purely radial load of constant magnitude and direction

Equivalent dynamic bearing load

The basic rating life equation $L = (C_r/P)^P$ used in the dimensioning of bearings under dynamic load assumes a load of constant magnitude and direction. In radial bearings, this is a purely radial load F_r . If this condition is met, the bearing load F_r is used in the rating life equation for P ($P = F_r$) ▶ 810 | f1 1.

f1 1
Equivalent dynamic load
Legend

$$P = F_r$$

P	N	Equivalent dynamic bearing load
F_r	N	Radial load.

Permissible dynamic bearing load

Maximum values in accordance with ▶ 810 | f5 apply to dynamic bearing load P .

f5
Permissible dynamic bearing load

Fundamentally valid for	Valid up to bore diameter $d \leq 200$ mm for
P	
$P \leq 0,33 C_r$	$P \leq 0,18 C_{0r}$



In applications with very high dynamic loads, the rating life calculation must be carried out in greater detail. In such cases, please consult Schaeffler.

Equivalent static bearing load

For toroidal bearings subjected to static load ▶ 810 | f2.

f2
Equivalent static load
Legend

$$P_0 = F_r$$

P_0	N	Equivalent static bearing load
F_r	N	Largest radial load present (maximum load).

Static load safety factor

In addition to the basic rating life L (L_{10h}), it is also always necessary to check the static load safety factor S_0 ▶ 810 | f3.

f3
Static load safety factor

$$S_0 = \frac{C_0}{P_0}$$

S_0	-	Static load safety factor
C_0	N	Basic static load rating
P_0	N	Equivalent static bearing load.

1.15 Minimum load

In order to prevent damage due to slippage, a minimum radial load is required

In order that no slippage occurs between the contact partners, the toroidal roller bearings must be constantly subjected to a sufficiently high radial load. This applies in particular to high speed bearings since, if the radial load is not present, damaging sliding motion may occur between the rolling elements and raceways. Based on experience, a minimum load is thus necessary $\blacktriangleright 811 | \text{fig. 4}$. In most cases, however, the radial load is already higher than the requisite minimum load $F_{r \min}$ due to the weight of the supported parts and the external forces.

fig. 4
Minimum radial load

$$F_{r \min} = 0,0135 \cdot C_0$$

Legend

$F_{r \min}$	kN	Minimum radial load
C_0	kN	Basic static load rating $\blacktriangleright 832 \text{table}$



If the minimum radial load $F_{r \min} \leq 0,0135 \cdot C_0$, please consult Schaeffler.

Minimum radial load with oil lubrication

Values can be determined from a diagram or by calculation

If oil lubrication is used, the requisite minimum load $F_{r \min}$ is reduced as a function of the bearing type and speed. $F_{r \min}$ can be determined for this operating condition:

- with the aid of a diagram, whereby $F_{r \min}$ is read off relative to C_0 $\blacktriangleright 811 | \text{fig. 11}$
- by calculation $\blacktriangleright 812 | \text{fig. 6}$ and $\blacktriangleright 812 | \text{table 6}$.

Determining the minimum radial load with the aid of a diagram

fig. 5
Determining ancillary value k_r

In order to calculate $F_{r \min}$, the ancillary value k_r must first be determined $\blacktriangleright 811 | \text{fig. 5}$.

fig. 5
Ancillary value

$$k_r = k_\delta \cdot d_M$$

Legend

k_r	-	Ancillary value
k_δ	-	Operating clearance factor $\blacktriangleright 832 \text{table}$
d_M	mm	Mean bearing diameter $(d+D)/2$.

Reading off the minimum radial load from a diagram

With the aid of the ancillary value k_r and the speed ratio $n/n_{\partial r}$, the requisite minimum load can be read off relative to the basic static load rating C_0 $\blacktriangleright 811 | \text{fig. 11}$.

fig. 11
Minimum radial load with oil lubrication

- $F_{r \min}$ = minimum radial load
- C_0 = basic static load rating $\blacktriangleright 832 | \text{table}$
- n = operating speed
- $n_{\partial r}$ = speed rating $\blacktriangleright 832 | \text{table}$
- k_r = ancillary value $\blacktriangleright 811 | \text{fig. 5}$

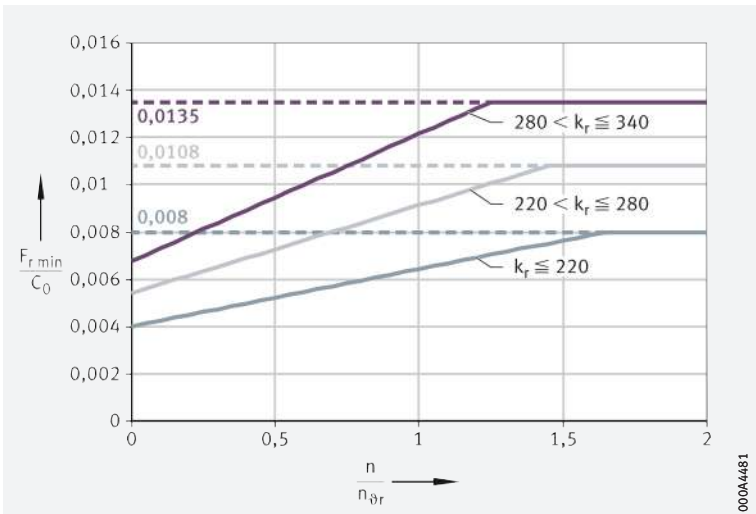

000A4481

Determining the minimum radial load by calculation

As an alternative to using a diagram, the requisite minimum radial load can also be determined by calculation ▶812| 6 to ▶812| 8.

f16
Factor f_n , if $n < n_K \cdot n_{\partial r}$

$$f_n = 0,5 \cdot \left(1 + \frac{n}{n_{\partial r} \cdot n_K} \right)$$

f17
Factor f_n , if $n \geq n_K \cdot n_{\partial r}$

$$f_n = 1$$

Legend

f_n	-	Factor for determining the influence of speed. In the case of full complement bearings: $f_n = 1$
n	min ⁻¹	Operating speed
$n_{\partial r}$	min ⁻¹	Speed rating ▶832 6
n_K	-	Speed parameter ▶812 6.

f18
Minimum radial load

$$F_{r \min} = f_F \cdot f_n \cdot C_0$$

Legend

$F_{r \min}$	kN	Minimum radial load
f_F	-	Factor due to influence of load ▶812 6
f_n	-	Factor due to influence of speed ▶812 f16 and ▶812 f17
C_0	kN	Basic static load rating ▶832 6.



Higher minimum radial loads may also be necessary under certain conditions when starting up at low temperature, when using greases with a high base oil viscosity and where bearings have been regreased.

As a function of k_r , the factors for calculation of the minimum load should be selected as follows ▶812| 6.

6
Factors for calculation of minimum radial load

Ancillary value		Factor due to influence of load	Speed parameter
k_r		f_F	n_K
over	incl.		
-	220	0,0080	1,65
220	280	0,0108	1,45
280	340	0,0135	1,25

Calculation example 1:

Determining the minimum radial load $F_{r \min}$ with the aid of a diagram

Task The aim is to determine the minimum radial load $F_{r \min}$ for toroidal roller bearing C3144-XL-K-C4 using a diagram \blacktriangleright 813 | $\text{f}9$ and \blacktriangleright 813 | $\text{Q}12$. The operating speed $n = 260 \text{ min}^{-1}$, the static load carrying capacity of the bearing $C_{0r} = 2\,900 \text{ kN}$.

$\text{f}9$ Ancillary value	$k_r = k_\delta \cdot d_M$
Calculation factor \blacktriangleright 832 $\text{f}9$	$k_\delta = 0,791$
Mean bearing diameter \blacktriangleright 832 $\text{f}9$	$d_M = \frac{220 \text{ mm} + 370 \text{ mm}}{2} = 295 \text{ mm}$
Ancillary value \blacktriangleright 813 $\text{f}9$	$k_r = 0,791 \cdot 295 \text{ mm} = 233,345 \text{ mm} \approx 233 \text{ mm}$
Speed ratio \blacktriangleright 813 $\text{Q}12$	$\frac{n}{n_{\vartheta r}} = \frac{260 \text{ min}^{-1}}{960 \text{ min}^{-1}} = 0,27$

The middle curve applies $k_r = 233 \text{ mm}$, therefore the middle (grey) curve is selected in the diagram \blacktriangleright 813 | $\text{Q}12$. $n/n_{\vartheta r} = 0,27$ for $F_{r \min}/C_0 = 0,0064$.

$\text{Q}12$ Minimum radial load with oil lubrication

$F_{r \min}$ = minimum radial load
 C_0 = basic static load rating
 \blacktriangleright 832 | $\text{f}9$
 n = operating speed
 $n_{\vartheta r}$ = speed rating \blacktriangleright 832 | $\text{f}9$
 k_r = ancillary value \blacktriangleright 813 | $\text{f}9$

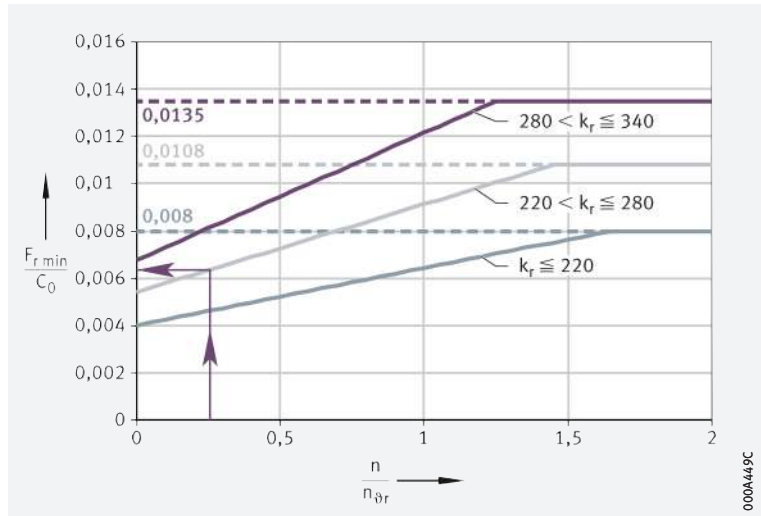

\blacktriangleright $F_{r \min}$

Calculate the minimum radial load for C3144-XL-K-C4:



$$F_{r \min} = 0,0064 \cdot 2\,900 \text{ kN} = 18,6 \text{ kN}$$



Calculation example 2:
Determining the minimum radial load $F_{r \min}$ by calculation

 **Task** The aim is to determine the minimum radial load $F_{r \min}$ for toroidal roller bearing C3144-XL-K-C4 by calculation ➤ 814 | f10, ➤ 814 | f11 and ➤ 812 | 6. The operating speed $n = 260 \text{ min}^{-1}$, the static load carrying capacity of the bearing $C_{0r} = 2\,900 \text{ kN}$.

If $k_r \approx 233 \text{ mm}$ is taken from Example 1, this gives:

■ $n_K = 1,45$ ➤ 812 | 6

■ $f_F = 0,0108$ ➤ 812 | 6.

If $n_{\partial r} \cdot n_K = 960 \text{ min}^{-1} \cdot 1,45 = 1\,392 \text{ min}^{-1} > 260 \text{ min}^{-1}$, this gives ➤ 814 | f10 and ➤ 814 | f11.

f10
Factor for determining
the influence of speed

$$f_n = 0,5 \cdot \left(1 + \frac{n}{n_{\partial r} \cdot n_K} \right)$$



$$f_n = 0,5 \cdot \left(1 + \frac{260 \text{ min}^{-1}}{960 \text{ min}^{-1} \cdot 1,45} \right) = 0,593$$

f11
Minimum radial load

$$F_{r \min} = f_F \cdot f_n \cdot C_0$$



$$F_{r \min} = 0,0108 \cdot 0,593 \cdot 2\,900 \text{ kN} \approx 18,6 \text{ kN}$$

1.16 Design of bearing arrangements

☞ *Support bearing rings over their entire circumference and width*

In order to allow full utilisation of the load carrying capacity of the bearings and achieve the requisite rating life, the bearing rings must be rigidly and uniformly supported by means of contact surfaces over their entire circumference and over the entire width of the raceway. Support can be provided by means of a cylindrical or tapered seating surface ▶816|📄13 to ▶820|📄16. The seating and contact surfaces should not be interrupted by grooves, holes or other recesses. The accuracy of mating parts must meet specific requirements ▶817|📄7 to ▶818|📄9.

Radial location – fit recommendations for bearings with cylindrical bore

☞ *For secure radial location, tight fits are necessary*

In addition to supporting the rings adequately, the bearings must also be securely located in a radial direction, to prevent creep of the bearing rings on the mating parts under load. This is generally achieved by means of tight fits between the bearing rings and the mating parts. If the rings are not secured adequately or correctly, this can cause severe damage to the bearings and adjacent machine parts. Influencing factors, such as the conditions of rotation, magnitude of the load, internal clearance, temperature conditions, design of the mating parts and the mounting and dismounting options must be taken into consideration in the selection of fits.



If shock type loads occur, tight fits (transition fit or interference fit) are required to prevent the rings from coming loose at any point. Clearance, transition or interference fits ▶150|📄6 and ▶158|📄7.



The following information provided in Technical principles must be taken into consideration in the design of bearing arrangements:

- conditions of rotation ▶145
- tolerance classes for cylindrical shaft seats (radial bearings) ▶147|📄2
- shaft fits ▶150|📄6
- tolerance classes for bearing seats in housings (radial bearings) ▶148|📄4
- housing fits ▶158|📄7
- shaft tolerances for adapter sleeves and withdrawal sleeves ▶166|📄8.

Axial location – bearings with cylindrical bore

☞ *The bearings must also be securely located in an axial direction*

As a tight fit alone is not normally sufficient to also locate the bearing rings securely on the shaft and in the housing bore in an axial direction, this must usually be achieved by means of an additional axial location or retention method. The axial location of the bearing rings must be matched to the type of bearing arrangement. Shaft and housing shoulders, housing covers, nuts, spacer rings and retaining rings etc., are fundamentally suitable.



Location by means of locknut and tab washer

Axial location – bearings with tapered bore

If a bearing with a tapered bore is mounted directly on a tapered journal, the bearing can be axially located with ease using a locknut and tab washer ▶ 816 | 13.

13
Toroidal roller bearing with tapered bore, mounted directly on the tapered shaft journal

- ① Tapered journal with fixing thread
- ② Locknut
- ③ Tab washer

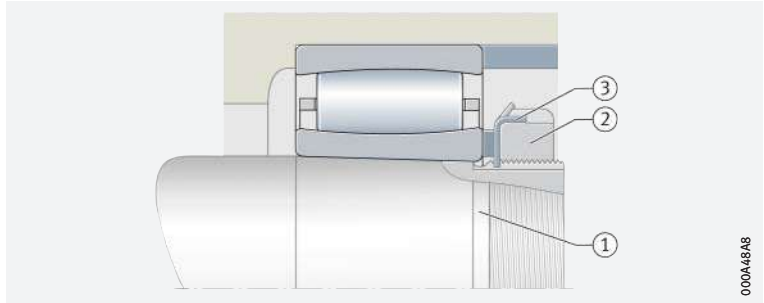

Mounting can be carried out quickly and reliably by means of wrench sets from Schaeffler

Location of bearings by means of adapter sleeve or withdrawal sleeve

Toroidal roller bearings with a tapered bore can be located easily and with operational reliability on smooth or stepped cylindrical shafts by means of an adapter sleeve or withdrawal sleeve ▶ 816 | 14. The adapter sleeve does not need to be secured on the shaft by any additional means. The bearings can be positioned at any point on smooth shafts.

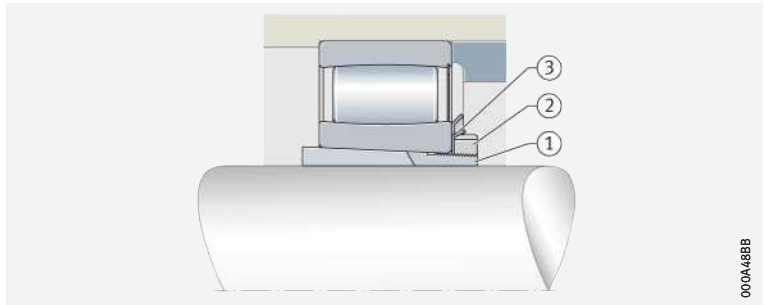

14
Toroidal roller bearing with adapter sleeve, located on smooth shaft

- ① Adapter sleeve
- ② Locknut
- ③ Tab washer



Dimensional, geometrical and running accuracy of cylindrical bearing seats

☞ A minimum of IT6 should be provided for the shaft seat and a minimum of IT7 for the housing seat

The accuracy of the cylindrical bearing seat on the shaft and in the housing should correspond to the accuracy of the bearing used. For toroidal roller bearings with the tolerance class Normal, the shaft seat should correspond to a minimum of standard tolerance grade IT6 and the housing seat to a minimum of IT7. Guide values for the geometrical and positional tolerances of bearing seating surfaces ▶ 817  7, tolerances t_1 to t_3 in accordance with ▶ 168  11. Numerical values for IT grades ▶ 817  8.

 7
Guide values for the geometrical and positional tolerances of bearing seating surfaces

Bearing tolerance class		Bearing seating surface	Standard tolerance grades to ISO 286-1 (IT grades)			
to ISO 492	to DIN 620		Diameter tolerance	Roundness tolerance	Parallelism tolerance	Total axial runout tolerance of abutment shoulder
				t_1	t_2	t_3
Normal	PN (P0)	Shaft	IT6 (IT5)	Circumferential load IT4/2	Circumferential load IT4/2	IT4
				Point load IT5/2	Point load IT5/2	
		Housing	IT7 (IT6)	Circumferential load IT5/2	Circumferential load IT5/2	IT5
				Point load IT6/2	Point load IT6/2	
5	P5	Shaft	IT5	Circumferential load IT2/2	Circumferential load IT2/2	IT2
				Point load IT3/2	Point load IT3/2	
		Housing	IT6	Circumferential load IT3/2	Circumferential load IT3/2	IT3
				Point load IT4/2	Point load IT4/2	

 8
Numerical values for ISO standard tolerances (IT grades) to ISO 286-1:2010

IT grade	Nominal dimension in mm									
	over 50	80	120	180	250	315	400	500	630	800
	incl. 80	120	180	250	315	400	500	630	800	1 000
Values in μm										
IT4	8	10	12	14	16	18	20	22	25	28
IT5	13	15	18	20	23	25	27	32	36	40
IT6	19	22	25	29	32	36	40	44	50	56
IT7	30	35	40	46	52	57	63	70	80	90



☞ *Ra must not be too high*

Roughness of cylindrical bearing seating surfaces

The roughness of the bearing seats must be matched to the tolerance class of the bearings. The mean roughness value Ra must not be too high, in order to maintain the interference loss within limits. The shafts must be ground, while the bores must be precision turned. Guide values as a function of the IT grade of bearing seating surfaces ➤ 818 | 9.

9
Roughness values
for cylindrical bearing seating
surfaces – guide values

Nominal diameter of the bearing seat d (D) mm		Recommended mean roughness value for ground bearing seats Ramax µm			
		Diameter tolerance (IT grade)			
over	incl.	IT7	IT6	IT5	IT4
–	80	1,6	0,8	0,4	0,2
80	500	1,6	1,6	0,8	0,4
500	1 250	3,2 ¹⁾	1,6	1,6	0,8

¹⁾ For the mounting of bearings using the hydraulic method, a value Ra = 1,6 µm must not be exceeded.

Tolerances for tapered bearing seats

☞ *Specifications for tapered bearing seats*

For bearings located directly on a tapered shaft journal ➤ 816 | 13, the data are in accordance with ➤ 171 | 12.

Mounting dimensions for the contact surfaces of bearing rings

☞ *The contact surfaces for the rings must be of sufficient height*

The mounting dimensions of the shaft and housing shoulders, and spacer rings etc., must ensure that the contact surfaces for the bearing rings are of sufficient height. However, they must also reliably prevent rotating parts of the bearing from grazing stationary parts. Proven mounting dimensions for the radii and diameters of the abutment shoulders ➤ 832 | 11. These dimensions are limiting dimensions (maximum or minimum dimensions); the actual values should not be higher or lower than specified.

Calculating minimum values

Required axial free space

Toroidal roller bearings can compensate thermally-induced changes in the length of the shaft relative to the housing within the bearing. In order to ensure the function of the bearings, free space must be provided on both end faces of the bearings **► 819** | **15**.

The minimum values recommended by Schaeffler for the depth of the free space are in accordance with **► 819** | **f 12**.

f 12
Requisite value for the depth of the free space

$$C_{a \text{ req}} = C_a + 0,5 \cdot (\delta_{ax} + s_{\varphi})$$

Legend

$C_{a \text{ req}}$	mm	Requisite value for the depth of the free space ► 819 15
C_a	mm	Minimum value for depth of free space in the case of bearing rings without offset ► 832 17
δ_{ax}	mm	Axial displacement from central position
s_{φ}	mm	Reduction in axial displacement facility as a result of tilting ► 823 f 17 .

15
Free space in the housing for toroidal roller bearings with a cage

$C_{a \text{ req}}$ = requisite value for the depth of the free space

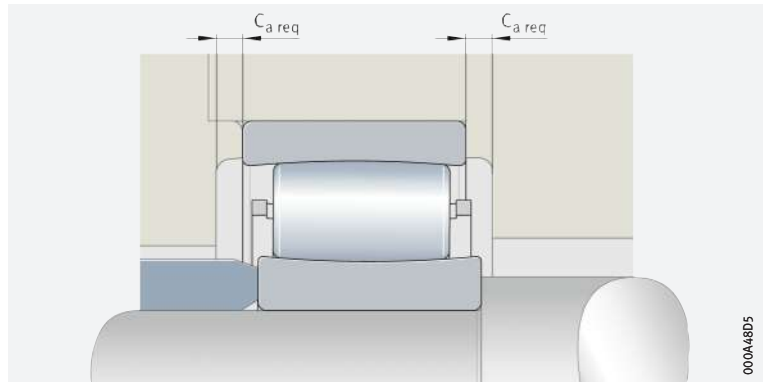

☞ *Suitable for significant changes in length in one direction*

☞ *Axial fixing elements*

Offset mounting

In standard mounting, the bearing rings are fitted concentrically in relation to each other. If significant changes in length occur in one direction in the application due to heat, the inner ring can be fitted offset relative to the outer ring in the opposing direction by up to the maximum permissible axial displacement. As a result, there is a significant increase in the possible axial displacement.

Toroidal roller bearings can be axially located by means of shaft nuts KML or KM and tab washers MBL or MB ▶ 820 | 16. For bearings with a bore diameter larger than 200 mm, nuts of series HM30 should be used with retaining bracket MS30.



In the axial location of toroidal roller bearings with retaining nuts, it must be ensured that the cage of the bearing does not graze the retaining nut or tab washer if the shaft undergoes axial displacement. The outside diameter of the retaining nut should always be smaller than the stated mounting dimension $d_{a\max}$. If this is not possible, an intermediate ring can be arranged between the bearing and means of retention and the thread on the shaft can be made correspondingly longer.

16
Toroidal roller bearing
on adapter sleeve

C_a = minimum value for free space in the case of bearings with cage and rings without offset, or required free space with offset bearing rings

r_a = maximum chamfer dimension
▶ 832 | 832

d_a = maximum or minimum abutment height for inner ring
▶ 832 | 832

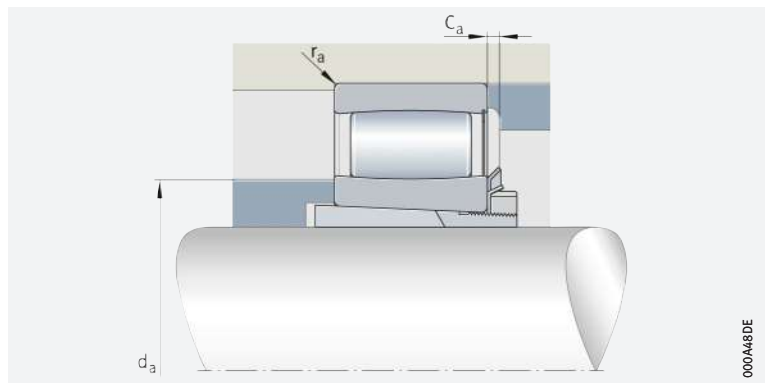

000A48DE

Possible axial displacement of the bearing rings relative to each other from the central position

🔗 *Conditions for s_1 and s_2*

Toroidal roller bearings compensate axial displacement of the shaft relative to the housing within the bearing ➤ 800 | 1.1. As a result, they can accommodate thermal expansion or deviations from the required bearing position within certain limits. The maximum displacement distances s_1 and s_2 in the product tables apply only where a sufficiently large operating clearance is present and to untilted bearing rings.



Axial displacement and tilting of the bearing rings changes the position of the rolling element in the bearing and thus also the operating clearance. In order to ensure that the axial displacement distance is available, the free space on both sides of the bearing must be maintained ➤ 819 | 15 and ➤ 819 | 12.

Factors which restrict the axial displacement of the bearing rings

🔗 *Roller offset and operating clearance restrict the axial displacement of the bearing rings*

The possible axial displacement of one bearing ring relative to the other from the central position is limited by:

- the restriction of the roller offset (geometrical restriction)
- the restriction of the operating clearance.

🔗 *Parameters which must be fulfilled for a reliable function*

In order to ensure the function of toroidal roller bearings in operation, the following must always be checked when designing the bearing position:

- The axial displacement of the bearing rings in combination with any tilting lies within the permitted displacement distance s_1 or s_2 ➤ 832 | 11 respectively
- Sufficient operating clearance is present under axial displacement, tilting and under axial displacement and tilting (since the axial displacement and tilting of the bearing rings changes the bearing clearance).

Determining the resulting bearing clearance

The resulting bearing clearance can be determined using the following equation:

f 13
Resulting bearing clearance

$$s_{res} = s_{ini} - k_{\delta} \cdot (\delta_{ax} + k_{\varphi} \cdot \varphi)^2$$

Legend

s_{res}	μm	Resulting bearing clearance after tilting and axial displacement
s_{ini}	μm	Radial internal clearance after mounting
k_{δ}	-	Operating clearance factor ➤ 832 11
δ_{ax}	mm	Axial displacement from central position
k_{φ}	-	Tilting factor ➤ 832 11
φ	°	Tilting between inner ring and outer ring (misalignment ± shaft deflection).



Other influences such as differences in temperature between the inner ring and outer ring must also be taken into consideration.

The axial displacement facility is reduced here

Restriction of the axial displacement facility by the roller offset

Tilting causes axial displacement of the rollers from the central position. This means that the axial displacement facility of the bearing rings relative to each other is reduced by s_{φ} . The reduction in the axial displacement facility due to tilting can be calculated ▶822 | f14.

f14
Reduction in the axial displacement facility

$$s_{\varphi} = k_{\varphi} \cdot \varphi$$

Legend

s_{φ}	mm	Reduction in axial displacement facility as a result of tilting
k_{φ}	-	Tilting factor ▶832 f14
φ	°	Tilting between inner ring and outer ring (misalignment ± shaft deflection).

When tilting occurs at the same time, this gives the maximum possible axial displacement facility ▶822 | f15 and ▶822 | f16.

f15
Maximum axial displacement facility

$$s_{red} = s_1 - s_{\varphi}$$

In the case of full complement bearings, there is an additional effect as follows:

f16
Maximum axial displacement facility

$$s_{red} = s_2 - s_{\varphi}$$

Legend

s_{red}	mm	Maximum axial displacement facility under tilting
s_1	mm	Maximum axial displacement facility ▶832 f14 in the case of full complement bearings in the opposing direction to the retaining ring
s_{φ}	mm	Reduction in axial displacement facility as a result of tilting
s_2	mm	Maximum axial displacement facility ▶832 f14 in the case of full complement bearings in the direction of the retaining ring.

Restriction of axial displacement due to reduction in radial bearing clearance

Influences on the reduction of the bearing clearance

The bearing clearance is reduced in the following cases:

- axial displacement
- tilting of the bearing from the central position
- axial displacement and tilting of the bearing from the central position.



Depending on the necessary operating clearance, it must be checked whether the required axial displacement is possible under the tilting present.

The reduction in operating clearance is calculated in accordance with **823** | **f17**.

f17
Reduction in radial bearing clearance

$$\Delta s = k_{\delta} \cdot (\delta_{ax} + k_{\varphi} \cdot \varphi)^2$$

Legend

Δs	μm	Reduction in radial bearing clearance
k_{δ}	-	Operating clearance factor 832
δ_{ax}	mm	Axial displacement
k_{φ}	-	Tilting factor 832
φ	°	Tilting between inner ring and outer ring (misalignment \pm shaft deflection).

Calculation example

Bearing data

The toroidal roller bearing C3144-XL-K-C4 with a tapered bore is supplied with a radial internal clearance of 390 μm . The operating clearance in the central position is only 240 μm due to mounting.

$$k_{\varphi} = 13,67 \text{ **832** |$$

$$\varphi = 0,2$$

$$s_1 = 22,3 \text{ **832** |$$

Dryer roll application

In the dryer roll, the misalignment is 0,2° and the shaft also undergoes thermal elongation of 6,3 mm.

Questions:

- Is this displacement permissible in addition to the tilting?
- What is the change in the operating clearance?

f18
Reduction in the axial displacement facility

$$s_{\varphi} = k_{\varphi} \cdot \varphi$$



$$s_{\varphi} = 13,67 \cdot 0,2 \approx 2,73 \text{ mm}$$

Legend

s_{φ}	mm	Reduction in axial displacement facility as a result of tilting
k_{φ}	-	Tilting factor 832
φ	°	Tilting between inner ring and outer ring (misalignment \pm shaft deflection).



f 19
Maximum axial displacement



$$s_{red} = s_1 - s_\varphi$$

$$s_{red} = 22,30 \text{ mm} - 2,73 \text{ mm} = 19,57 \text{ mm}$$

The axial displacement by 6,3 mm is in the permissible range of 19,57 mm in combination with tilting by 0,2°. The application must now be checked in relation to the reduction in operating clearance.

$$k_\delta = 0,791 \text{ } \blacktriangleright \text{ 832} \text{ } \left[\frac{\text{mm}}{\text{mm}^2} \right]$$

$$\delta_{ax} = 6,30 \text{ mm}$$

f 20
Resulting operating clearance



$$s_{res} = s_{ini} - k_\delta \cdot (\delta_{ax} + k_\varphi \cdot \varphi)^2$$

$$s_{res} = 240 \text{ } \mu\text{m} - 0,791 \cdot (6,3 + 2,73)^2 \approx 175 \text{ } \mu\text{m}$$

The resulting operating clearance after tilting and axial displacement is 175 μm.



The influence of the difference in temperature between the inner ring and outer ring must also be taken into consideration.

The axial displacement facility for the bearing C3144-XL-K-C4 is shown as an example [▶ 824 | 17](#). The actual internal clearance as a function of axial displacement is shown in relation to the bearing width.

17
Resulting operating clearance s_{res} , shown using the example of toroidal roller bearing C3144-XL-K-C4, as a function of tilting and axial displacement

s_{res} = operating clearance
 δ_{ax} = axial displacement
 φ = tilting

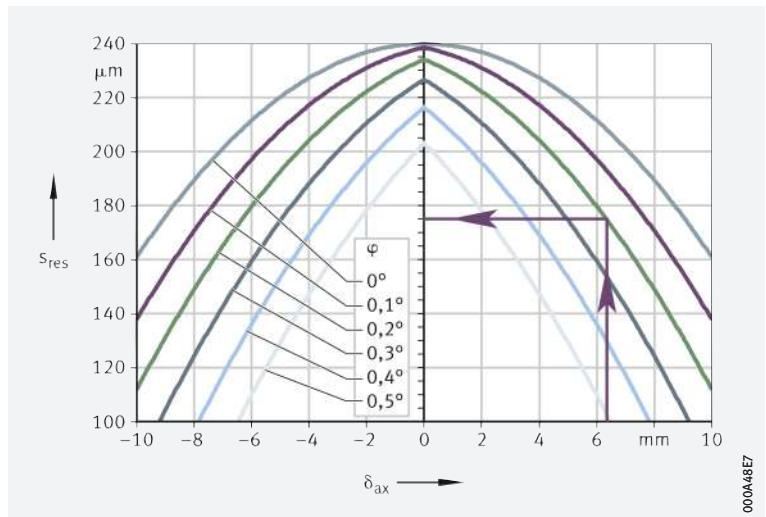

A large range of housings is available

Suitable bearing housings for toroidal roller bearings

For economical, operationally reliable and easily interchangeable bearing arrangement units, toroidal roller bearings can also be combined with Schaeffler bearing housings ► 825 |  18. These easy-to-fit units fulfil all of the requirements for modern machine and plant designs with favourable maintenance-related characteristics.



Due to the large number of application areas, an extensive range of bearing housings is available for bearings with cylindrical and tapered bores. These include split and unsplit plummer block housings, take-up housings, flanged housings and housings for specific industrial and railway applications. Detailed information on bearing housings can be found in publication GK 1 ► <https://www.schaeffler.de/std/1D54>. This book can be ordered from Schaeffler.



18
Bearing housing with
toroidal roller bearing

- ① Toroidal roller bearing
- ② Bearing housing



000444AE



1.17 Mounting and dismounting



The mounting and dismounting options for toroidal roller bearings, by thermal, hydraulic or mechanical methods, must be taken into consideration in the design of the bearing position. The hydraulic method should be used in preference for the mounting and dismounting of larger bearings on a tapered journal and on adapter or withdrawal sleeves. In cases where a bearing failure may result in a production stoppage and incur high costs, monitoring of rolling bearings is advisable.

Special tool
extractor PULLER-SPECIAL-E

The extractor PULLER-SPECIAL-E is a special tool for the dismounting of spherical roller bearings and toroidal roller bearings. The dismounting tool has specially produced fingers that grip behind the end faces of the rollers. The extractor then presses on the shaft by means of a hydraulic cylinder and pulls the bearing out.

Ensure that the bearings are not damaged during mounting

Toroidal roller bearings are not separable. In the mounting of non-separable bearings, the mounting forces must always be applied to the bearing ring with a tight fit.

Mounting on a horizontally aligned shaft

During mounting of the bearings, the bearing rings can become axially displaced from the central position. For this reason, toroidal roller bearings should be mounted on horizontally aligned shafts and in appropriately aligned housing bores. In order that the bearing rings and roller set can achieve concentric alignment during mounting, the inner and outer ring should be rotated a couple of times on assembly.



If the intention is to mount the toroidal roller bearings on a vertically aligned shaft or in a vertically aligned housing bore, it should be noted that the outer and inner ring, complete with roller and cage assembly, will be displaced downwards. This will, in turn, have an effect on the internal clearance. If the user has no experience in the design of such bearing arrangements, please consult Schaeffler.

Suitable methods for checking the fit strength

Mounting of bearings with a tapered bore

Bearings with a tapered bore are mounted with a tight fit on the shaft or on the adapter or withdrawal sleeve. Proven methods for checking the strength of the fit involve measuring:

- the reduction in radial internal clearance
- the axial drive-up distance of the inner ring on the tapered bearing seat
- the tightening angle of the fixing nut.

Measurement with a feeler gauge

Measuring the reduction in radial internal clearance

The reduction in radial internal clearance is the difference between the radial internal clearance before mounting and the bearing clearance after mounting of the bearing $\blacktriangleright 826 | \text{ } \text{ } 19$ and $\blacktriangleright 828 | \text{ } \text{ } 10$. The radial internal clearance must be measured first. During pressing on, the radial clearance (bearing clearance) must be checked until the necessary reduction in the radial internal clearance and thus the required tight fit is achieved $\blacktriangleright 828 | \text{ } \text{ } 10$.



19
Reduction in radial internal clearance

s_r = radial internal clearance before mounting

s_{r1} = radial internal clearance after mounting

$s_r - s_{r1}$ = reduction in radial internal clearance

① Before mounting

② After mounting

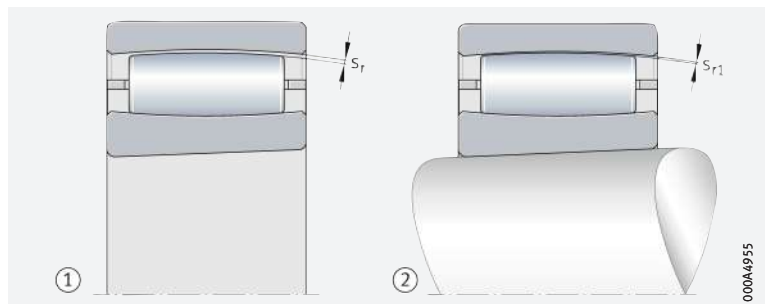

000A4955

Measuring the axial drive-up distance

The axial drive-up distance can also be measured in place of the reduction in radial internal clearance ► 383 | 14.

20 Axial drive-up distance

s_a = axial press-on distance
(axial drive-up distance
of the bearing)

s_r = radial internal clearance
before pressing on

s_{r1} = radial internal clearance
after pressing on

$s_r - s_{r1}$ = reduction in radial
internal clearance

① Before pressing on

② After pressing on

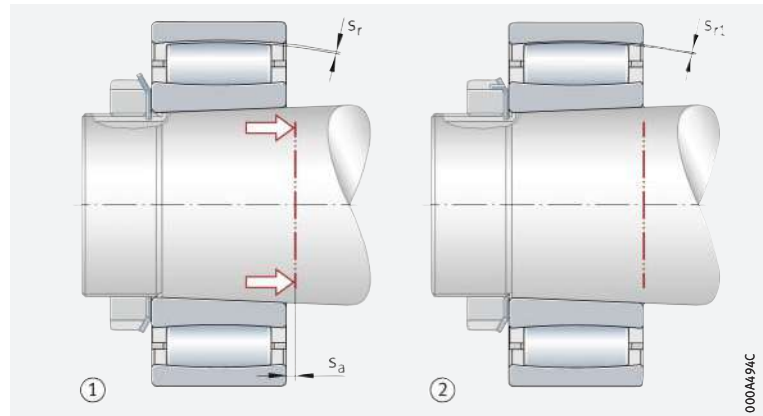

Example of calculation of the axial drive-up distance

Principal procedure

Toroidal roller bearing C2215-XL-K with adapter sleeve H2316:

■ Radial internal clearance before mounting

– 0,075 mm to 0,110 mm ► 828 | 10

■ Reduction in radial internal clearance during mounting

– 0,030 mm to 0,046 mm ► 828 | 10

■ Control value for radial internal clearance after mounting

– 0,045 mm ► 829 | 10

■ Axial drive-up distance, taper angle 1:12

– 0,55 mm to 0,61 mm ► 829 | 10.



The malfunction-free operation of toroidal roller bearings presupposes that these have been mounted correctly. An insufficient operating clearance or inadequately tight fit on the shaft generally leads to bearing damage.





If there is any uncertainty regarding the practical application of the methods, Schaeffler must always be consulted.



 **Reduced radial internal clearance in mounting**

Guide values for the reduction in radial internal clearance

When bearings with a tapered bore are mounted, there is a reduction in the radial internal clearance. Adherence to the indicated values ensures that the bearings or sleeve are securely seated on the shaft and prevents the inner ring from creeping on the shaft  10. The setting should not, however, be equated to the later appropriate operating clearance.

 **10**
Reduction in radial internal clearance in mounting of toroidal roller bearings with tapered bore

Nominal bore diameter		Radial internal clearance before mounting in accordance with DIN 620-4:2004 (ISO 5753-1:2009)						Reduction in radial internal clearance during mounting ¹⁾	
d mm		CN (Group N) mm		C3 (Group 3) mm		C4 (Group 4) mm			
over	incl.	min.	max.	min.	max.	min.	max.	min.	max.
24	30	0,035	0,055	0,050	0,065	0,065	0,085	0,010	0,017
30	40	0,045	0,065	0,060	0,080	0,080	0,100	0,014	0,021
40	50	0,050	0,075	0,070	0,095	0,090	0,120	0,018	0,028
50	65	0,060	0,090	0,085	0,115	0,110	0,150	0,024	0,035
65	80	0,075	0,110	0,105	0,140	0,135	0,180	0,030	0,046
80	100	0,095	0,135	0,130	0,175	0,170	0,220	0,040	0,056
100	120	0,115	0,155	0,155	0,205	0,200	0,255	0,049	0,069
120	140	0,135	0,180	0,180	0,235	0,230	0,295	0,060	0,083
140	160	0,155	0,215	0,210	0,270	0,265	0,340	0,072	0,095
160	180	0,170	0,240	0,235	0,305	0,300	0,385	0,081	0,107
180	200	0,190	0,260	0,260	0,330	0,325	0,420	0,090	0,121
200	225	0,210	0,290	0,285	0,365	0,360	0,460	0,101	0,134
225	250	0,235	0,315	0,315	0,405	0,400	0,515	0,113	0,151
250	280	0,255	0,345	0,340	0,445	0,440	0,560	0,126	0,168
280	315	0,280	0,380	0,375	0,485	0,480	0,620	0,142	0,188
315	355	0,315	0,420	0,415	0,545	0,540	0,680	0,160	0,211
355	400	0,350	0,475	0,470	0,600	0,595	0,755	0,180	0,238
400	450	0,380	0,525	0,525	0,655	0,650	0,835	0,203	0,268
450	500	0,435	0,575	0,575	0,735	0,730	0,915	0,225	0,300
500	560	0,470	0,640	0,640	0,810	0,800	1,010	0,250	0,335
560	630	0,530	0,710	0,710	0,890	0,880	1,110	0,285	0,375
630	710	0,590	0,780	0,770	0,990	0,980	1,230	0,320	0,420
710	800	0,670	0,860	0,860	1,100	1,100	1,380	0,360	0,475
800	900	0,730	0,960	0,950	1,220	1,210	1,530	0,405	0,535
900	1 000	0,810	1,040	1,040	1,340	1,340	1,670	0,450	0,605
1 000	1 120	0,890	1,170	1,160	1,500	1,490	1,880	0,505	0,670
1 120	1 250	0,970	1,280	1,270	1,640	1,630	2,060	0,565	0,750
1 250	1 400	1,080	1,410	1,410	1,790	1,780	2,250	0,630	0,840
1 400	1 600	1,200	1,550	1,550	1,990	1,990	2,500	0,720	0,940
1 600	1 800	1,320	1,690	1,690	2,180	2,180	2,730	0,810	1,070

¹⁾ Valid only for solid steel shafts and hollow shafts with a bore no larger than half the shaft diameter. The following applies: bearings with a radial internal clearance before mounting in the upper half of the tolerance range are mounted using the larger value for the reduction in radial internal clearance or the axial drive-up distance, while bearings in the lower half of the tolerance range are mounted using the smaller value for the reduction in radial internal clearance or the axial drive-up distance.

continued ▼

10

Axial drive-up distance of the inner ring in mounting of toroidal roller bearings with tapered bore

Nominal bore diameter		Drive-up distance on taper 1:12 ¹⁾		Drive-up distance on taper 1:30 ¹⁾		Minimum radial internal clearance required after mounting, control value with		
d		Shaft		Shaft		CN (Group N)	C3 (Group 3)	C4 (Group 4)
mm		mm		mm		mm	mm	mm
over	incl.	min.	max.	min.	max.	min.	min.	min.
24	30	0,24	0,29	0,61	0,72	0,025	0,035	0,048
30	40	0,30	0,34	0,76	0,84	0,031	0,041	0,059
40	50	0,37	0,42	0,91	1,04	0,033	0,046	0,062
50	65	0,46	0,50	1,14	1,24	0,036	0,054	0,075
65	80	0,55	0,61	1,37	1,53	0,045	0,065	0,090
80	100	0,67	0,73	1,68	1,83	0,056	0,080	0,114
100	120	0,79	0,89	1,98	2,23	0,066	0,093	0,131
120	140	0,91	1,05	2,29	2,62	0,075	0,105	0,147
140	160	1,04	1,21	2,59	3,02	0,083	0,123	0,170
160	180	1,16	1,36	2,90	3,41	0,089	0,137	0,193
180	200	1,28	1,52	3,20	3,81	0,100	0,150	0,204
200	225	1,43	1,68	3,58	4,20	0,109	0,162	0,226
225	250	1,59	1,88	3,96	4,69	0,123	0,177	0,249
250	280	1,77	2,08	4,42	5,19	0,129	0,186	0,273
280	315	1,98	2,31	4,95	5,78	0,138	0,203	0,292
315	355	2,23	2,59	5,56	6,47	0,155	0,221	0,329
355	400	2,50	2,90	6,25	7,26	0,170	0,251	0,357
400	450	2,81	3,26	7,01	8,15	0,178	0,279	0,382
450	500	3,11	3,66	7,78	9,14	0,210	0,300	0,430
500	560	3,48	4,05	8,69	10,13	0,220	0,325	0,465
560	630	3,90	4,52	9,76	11,31	0,245	0,355	0,505
630	710	4,39	5,08	10,98	12,69	0,270	0,380	0,560
710	800	4,94	5,71	12,35	14,27	0,310	0,425	0,625
800	900	5,55	6,42	13,88	16,05	0,325	0,460	0,675
900	1 000	6,16	7,21	15,40	18,03	0,360	0,490	0,735
1 000	1 120	6,89	8,00	17,23	20,00	0,385	0,545	0,820
1 120	1 250	7,69	8,95	19,21	22,37	0,410	0,580	0,880
1 250	1 400	8,60	9,98	21,50	24,94	0,450	0,640	0,940
1 400	1 600	9,82	11,16	24,55	27,90	0,480	0,685	1,050
1 600	1 800	11,04	12,74	27,60	31,85	0,510	0,705	1,110

continued ▲

¹⁾ Valid only for solid steel shafts and hollow shafts with a bore no larger than half the shaft diameter. The following applies: bearings with a radial internal clearance before mounting in the upper half of the tolerance range are mounted using the larger value for the reduction in radial internal clearance or the axial drive-up distance, while bearings in the lower half of the tolerance range are mounted using the smaller value for the reduction in radial internal clearance or the axial drive-up distance.



 *Rolling bearings must be handled with great care*

Schaeffler Mounting Handbook

Rolling bearings are well-proven precision machine elements for the design of economical and reliable bearing arrangements, which offer high operational security. In order that these products can function correctly and achieve the envisaged operating life without detrimental effect, they must be handled with care.



The Schaeffler Mounting Handbook MH 1 gives comprehensive information about the correct storage, mounting, dismounting and maintenance of rotary rolling bearings ► <https://www.schaeffler.de/std/1D53>. It also provides information which should be observed by the designer, in relation to the mounting, dismounting and maintenance of bearings, in the original design of the bearing position. This book is available from Schaeffler on request.

1.18

Legal notice regarding data freshness

 *The further development of products may also result in technical changes to catalogue products*

Of central interest to Schaeffler is the further development and optimisation of its products and the satisfaction of its customers. In order that you, as the customer, can keep yourself optimally informed about the progress that is being made here and with regard to the current technical status of the products, we publish any product changes which differ from the printed version in our electronic product catalogue.



We therefore reserve the right to make changes to the data and illustrations in this catalogue. This catalogue reflects the status at the time of printing. More recent publications released by us (as printed or digital media) will automatically precede this catalogue if they involve the same subject. Therefore, please always use our electronic product catalogue to check whether more up-to-date information or modification notices exist for your desired product.

Link to electronic product catalogue



The following link will take you to the Schaeffler electronic product catalogue: ► <https://medias.schaeffler.com>.

1.19 Further information

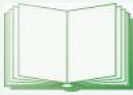

In addition to the data in this chapter, the following chapters in Technical principles must also be observed in the design of bearing arrangements:

- Determining the bearing size ▶ 34
- Rigidity ▶ 54
- Friction and increases in temperature ▶ 56
- Speeds ▶ 64
- Bearing data ▶ 97
- Lubrication ▶ 70
- Sealing ▶ 182
- Design of bearing arrangements ▶ 139
- Mounting and dismounting ▶ 191.





Toroidal roller bearings

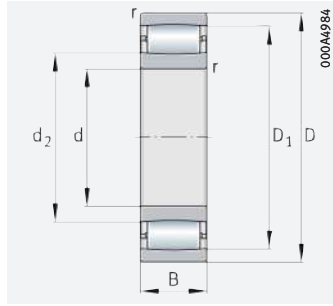

Cylindrical bore

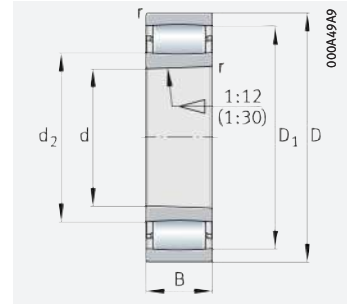

Tapered bore

d = 60 – 85 mm

Main dimensions			Basic load ratings		Fatigue limit load C_{ur} N	Limiting speed n_G min^{-1}	Speed rating $n_{\varnothing r}$ min^{-1}	Mass m \approx kg	Designation ▶ 809 1.12 ▶ 809 1.13 X-life ▶ 804
d	D	B	dyn. C_r N	stat. C_{0r} N					
60	110	28	171 000	195 000	32 500	2 650	–	1,12	C2212-XL-K-V
	110	28	171 000	195 000	32 500	2 650	–	1,15	C2212-XL-V
65	100	35	197 000	285 000	33 500	3 050	–	0,95	C4013-XL-K30-V
	100	35	197 000	285 000	33 500	3 050	–	0,98	C4013-XL-V
	120	31	208 000	216 000	36 000	2 340	–	1,48	C2213-XL-K-V
	120	31	208 000	216 000	36 000	2 340	–	1,52	C2213-XL-V
70	125	31	215 000	229 000	38 000	2 180	–	1,56	C2214-XL-K-V
	125	31	215 000	229 000	38 000	2 180	–	1,6	C2214-XL-V
	150	51	405 000	440 000	52 000	6 000	3 200	4,33	C2314-XL
	150	51	405 000	440 000	52 000	6 000	3 200	4,22	C2314-XL-K
75	115	40	209 000	355 000	39 500	2 470	–	1	C4015-XL-K30-V
	115	40	209 000	355 000	39 500	2 470	–	1,47	C4015-XL-V
	130	31	197 000	207 000	33 000	7 000	3 250	1,69	C2215-XL
	130	31	197 000	207 000	33 000	7 000	3 250	1,64	C2215-XL-K
	130	31	221 000	241 000	38 500	2 050	–	1,64	C2215-XL-K-V
	130	31	221 000	241 000	38 500	2 050	–	1,69	C2215-XL-V
	160	55	430 000	470 000	56 000	5 600	3 200	5,3	C2315-XL
	160	55	430 000	470 000	56 000	5 600	3 200	5,16	C2315-XL-K
80	140	33	224 000	250 000	41 000	6 300	2 900	2,1	C2216-XL
	140	33	224 000	250 000	41 000	6 300	2 900	2,05	C2216-XL-K
	140	33	260 000	305 000	49 500	1 790	–	2,05	C2216-XL-K-V
	140	33	260 000	305 000	49 500	1 790	–	2,1	C2216-XL-V
	170	58	510 000	550 000	62 000	5 100	3 050	6,3	C2316-XL
	170	58	510 000	550 000	62 000	5 100	3 050	6,1	C2316-XL-K
85	150	36	315 000	395 000	59 000	1 640	–	2,65	C2217-XL-V
	150	36	315 000	395 000	59 000	1 640	–	2,58	C2217-XL-K-V
	150	36	275 000	330 000	49 000	5 900	2 750	2,65	C2217-XL
	150	36	275 000	330 000	49 000	5 900	2 750	2,58	C2217-XL-K
	180	60	550 000	610 000	68 000	4 800	2 850	7,29	C2317-XL
	180	60	550 000	610 000	68 000	4 800	2 850	7,1	C2317-XL-K

medias ▶ <https://www.schaeffler.de/std/1E75>

Before ordering, availability for delivery must be checked.

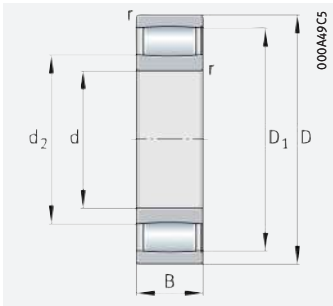

Full complement

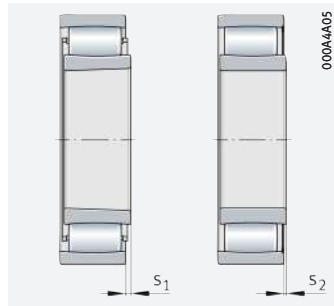

Axial displacement distance

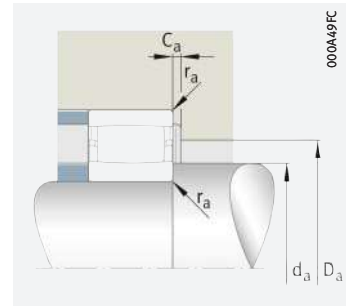

Mounting dimensions

Dimensions						Mounting dimensions						Calculation factors	
d	r	D ₁	d ₂	s ₁	s ₂	D _a		d _a		C _a	r _a	k _φ	k _δ
						max.	min.	max.	min.				
60	1,5	98,1	77,1	8,5	5,3	101	–	85	69	–	1,5	3,116	3,713
	1,5	98,1	77,1	8,5	5,3	101	–	85	69	–	1,5	3,116	3,713
65	1,1	88,6	74,7	6	2,8	94	–	82	71	–	1	3,543	3,082
	1,1	88,6	74,7	6	2,8	94	–	82	71	–	1	3,543	3,082
	1,5	106,1	78,9	9,6	5,3	111	–	97	74	–	1,5	3,298	3,505
	1,5	106,1	78,9	9,6	5,3	111	–	97	74	–	1,5	3,298	3,505
70	1,5	111,1	83,6	9,6	5,3	116	–	97	79	–	1,5	3,523	3,265
	1,5	111,1	83,6	9,6	5,3	116	–	97	79	–	1,5	3,523	3,265
	2,1	130,9	92,5	9,1	–	138	121	105	82	1,6	2	5,477	1,941
	2,1	130,9	92,5	9,1	–	138	121	105	82	1,6	2	5,477	1,941
75	1,1	100,2	89,5	9,4	5,1	109	–	97	81	–	1	3,893	2,845
	1,1	100,2	89,5	9,4	5,1	109	–	97	81	–	1	3,893	2,845
	1,5	115,4	88	9,6	–	121	110	96	84	1,11	1,5	3,56	3,268
	1,5	115,4	88	9,6	–	121	110	96	84	1,11	1,5	3,56	3,268
	1,5	115,4	88	9,6	5,3	121	–	102	84	–	1,5	3,56	3,268
	1,5	115,4	88	9,6	5,3	121	–	102	84	–	1,5	3,56	3,268
	2,1	136,5	99	13,1	–	148	127	111	87	1,5	2	5,53	1,941
2,1	136,5	99	13,1	–	148	127	111	87	1,5	2	5,53	1,941	
80	2	125,5	98,2	9,1	–	129	120	106	91	1,1	2	3,889	2,997
	2	125,5	98,2	9,1	–	129	120	106	91	1,1	2	3,889	2,997
	2	125,5	98,2	9,1	4,8	129	–	116	91	–	2	3,889	2,997
	2	125,5	98,2	9,1	4,8	129	–	116	91	–	2	3,889	2,997
	2,1	145,5	103,5	10,1	–	158	135	117	92	1,7	2	6,094	1,745
	2,1	145,5	103,5	10,1	–	158	135	117	92	1,7	2	6,094	1,745
85	2	132,2	104,8	7,1	1,7	139	–	117	96	–	2	4,194	2,763
	2	132,2	104,8	7,1	1,7	139	–	117	96	–	2	4,194	2,763
	2	132,2	104,8	7,1	–	139	126	113	96	1,1	2	4,194	2,763
	2	132,2	104,8	7,1	–	139	126	113	96	1,1	2	4,194	2,763
	3	153,9	111,1	12,1	–	166	143	125	99	1,72	2,5	6,144	1,752
	3	153,9	111,1	12,1	–	166	143	125	99	1,72	2,5	6,144	1,752





Toroidal roller bearings

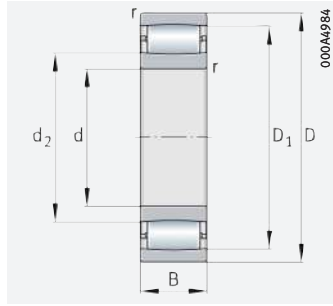

Cylindrical bore

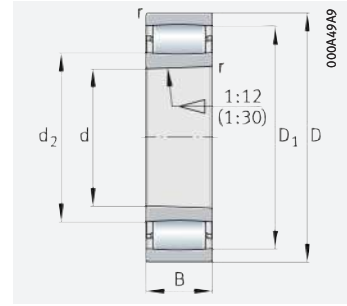

Tapered bore

d = 90 – 110 mm

Main dimensions			Basic load ratings		Fatigue limit load C_{ur} N	Limiting speed n_G min^{-1}	Speed rating $n_{\vartheta r}$ min^{-1}	Mass m ≈ kg	Designation ► 809 1.12 ► 809 1.13 X-life ► 804
d	D	B	dyn. C_r N	stat. C_{Or} N					
90	160	40	330 000	380 000	55 000	5 300	2 650	3,29	C2218-XL-K
	160	40	330 000	380 000	55 000	5 300	2 650	3,38	C2218-XL
	190	64	650 000	740 000	77 000	4 350	2 500	8,4	C2318-XL-K
	190	64	650 000	740 000	77 000	4 350	2 500	8,65	C2318-XL
95	170	43	370 000	405 000	61 000	5 000	2 750	4,01	C2219-XL-K
	170	43	370 000	405 000	61 000	5 000	2 750	4,12	C2219-XL
	200	67	660 000	750 000	78 000	4 350	2 600	9,75	C2319-XL-K
	200	67	660 000	750 000	78 000	4 350	2 600	10	C2319-XL
100	150	50	355 000	530 000	66 000	1 580	–	2,94	C4020-XL-K30-V
	150	50	355 000	530 000	66 000	1 580	–	3,02	C4020-XL-V
	165	52	490 000	660 000	86 000	1 330	–	4,21	C3120-XL-K-V
	165	52	490 000	660 000	86 000	1 330	–	4,32	C3120-XL-V
	165	65	530 000	730 000	83 000	1 350	–	5,26	C4120-XL-K30-V
	165	65	530 000	730 000	83 000	1 350	–	5,4	C4120-XL-V
	180	46	420 000	470 000	68 000	4 700	2 700	4,97	C2220-XL
	180	46	420 000	470 000	68 000	4 700	2 700	4,84	C2220-XL-K
215	73	820 000	920 000	97 000	3 850	2 290	12,4	C2320-XL-K	
	73	820 000	920 000	97 000	3 850	2 290	12,8	C2320-XL	
110	170	45	360 000	480 000	63 000	4 800	2 480	3,65	C3022-XL
	170	45	360 000	480 000	63 000	4 800	2 480	3,55	C3022-XL-K
	170	60	510 000	800 000	89 000	1 320	–	4,86	C4022-XL-V
	170	60	510 000	800 000	89 000	1 320	–	4,74	C4022-XL-K30-V
	180	69	680 000	1 000 000	104 000	1 160	–	6,58	C4122-XL-K30-V
	180	69	680 000	1 000 000	104 000	1 160	–	6,76	C4122-XL-V
	200	53	550 000	650 000	89 000	4 050	2 330	6,95	C2222-XL-K
	200	53	550 000	650 000	89 000	4 050	2 330	7,14	C2222-XL

medias ► <https://www.schaeffler.de/std/1E76>

Before ordering, availability for delivery must be checked.

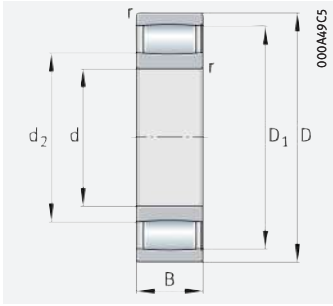

Full complement

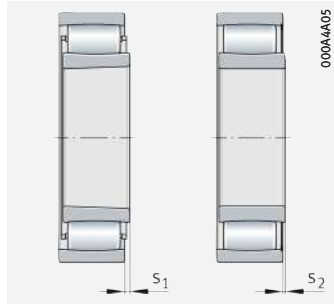

Axial displacement distance

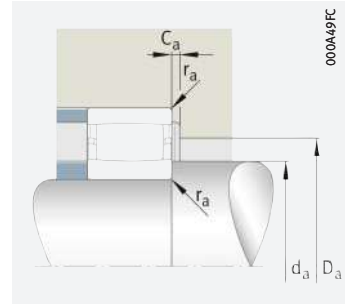

Mounting dimensions

Dimensions						Mounting dimensions						Calculation factors	
d	r	D ₁	d ₂	s ₁	s ₂	D _a		d _a		C _a	r _a	k _ψ	k _δ
						max.	min.	max.	min.				
90	2	143,9	112,1	9,5	–	149	137	122	101	1,3	2	4,103	2,924
	2	143,9	112,1	9,5	–	149	137	122	101	1,3	2	4,103	2,924
	3	167,4	119,6	9,6	–	176	154	136	104	1,9	2,5	6,754	1,589
	3	167,4	119,6	9,6	–	176	154	136	104	1,9	2,5	6,754	1,589
95	2,1	149,7	112,3	10,5	–	158	140	125	107	1,5	2	4,75	2,42
	2,1	149,7	112,3	10,5	–	158	140	125	107	1,5	2	4,75	2,42
	3	167,6	120,4	12,6	–	186	155	137	109	1,9	2,5	6,758	1,589
	3	167,6	120,4	12,6	–	186	155	137	109	1,9	2,5	6,758	1,589
100	1,5	133,6	113,6	14	9,7	141	–	125	109	–	1,5	4,766	2,365
	1,5	133,6	113,6	14	9,7	141	–	125	109	–	1,5	4,766	2,365
	2	150,7	119,7	10	4,7	154	–	132	111	–	2	6,699	1,582
	2	150,7	119,7	10	4,7	154	–	132	111	–	2	6,699	1,582
	2	147,4	120,6	17,7	5,2	154	–	132	111	–	2	5,69	1,929
	2	147,4	120,6	17,7	5,2	154	–	132	111	–	2	5,69	1,929
	2,1	156,9	118,1	10,1	–	168	147	131	112	1,6	2	4,849	2,393
	2,1	156,9	118,1	10,1	–	168	147	131	112	1,6	2	4,849	2,393
	3	184	129	11,2	–	201	169	148	114	2,2	2,5	8,026	1,312
	3	184	129	11,2	–	201	169	148	114	2,2	2,5	8,026	1,312
110	2	156,2	127,8	9,5	–	161	151	136	119	1,8	2	5,707	1,954
	2	156,2	127,8	9,5	–	161	151	136	119	1,8	2	5,707	1,954
	2	151,2	127,2	12	6,6	160	–	140	120	–	2	6,296	1,717
	2	151,2	127,2	12	6,6	160	–	140	120	–	2	6,296	1,717
	2	163	132,7	11,4	4,6	170	–	145	120	–	2	6,99	1,529
	2	163	132,7	11,4	4,6	170	–	145	120	–	2	6,99	1,529
	2,1	178,5	135,9	11,1	–	188	168	150	122	2	2	5,866	1,941
	2,1	178,5	135,9	11,1	–	188	168	150	122	2	2	5,866	1,941





Toroidal roller bearings

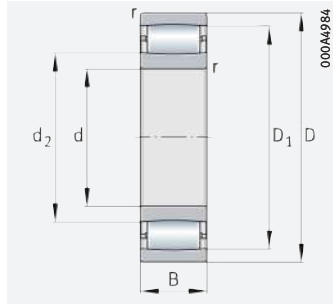

Cylindrical bore

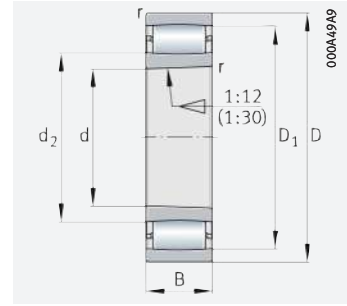

Tapered bore

d = 120 – 140 mm

Main dimensions			Basic load ratings		Fatigue limit load	Limiting speed	Speed rating	Mass	Designation ▶ 809 1.12 ▶ 809 1.13 X-life ▶ 804
d	D	B	dyn. C _r N	stat. C _{0r} N	C _{ur} N	n _G min ⁻¹	n _{∅r} min ⁻¹	m ≈ kg	
120	180	46	435 000	630 000	81 000	1 140	–	4	C3024-XL-V
	180	46	435 000	630 000	81 000	1 140	–	3,88	C3024-XL-K-V
	180	46	390 000	550 000	70 000	4 450	2 290	4	C3024-XL
	180	46	390 000	550 000	70 000	4 450	2 290	3,89	C3024-XL-K
	180	60	550 000	890 000	99 000	1 120	–	5,08	C4024-XL-K30-V
	180	60	550 000	890 000	99 000	1 120	–	5,2	C4024-XL-V
	200	80	780 000	1 140 000	124 000	1 030	–	9,63	C4124-XL-K30-V
	200	80	780 000	1 140 000	124 000	1 030	–	9,88	C4124-XL-V
	215	58	630 000	740 000	101 000	3 700	2 200	8,91	C2224-XL
	215	58	630 000	740 000	101 000	3 700	2 200	8,68	C2224-XL-K
	215	76	760 000	1 000 000	92 000	3 700	1 960	11,3	C3224-XL-K
	215	76	760 000	1 000 000	92 000	3 700	1 960	11,7	C3224-XL
130	200	52	405 000	600 000	74 000	4 000	2 210	5,63	C3026-XL-K
	200	52	405 000	600 000	74 000	4 000	2 210	5,8	C3026-XL
	200	69	730 000	1 130 000	119 000	990	–	7,49	C4026-XL-K30-V
	200	69	730 000	1 130 000	119 000	990	–	7,69	C4026-XL-V
	210	80	840 000	1 240 000	129 000	910	–	10,2	C4126-XL-K30-V
	210	80	840 000	1 240 000	129 000	910	–	10,5	C4126-XL-V
	230	64	760 000	970 000	119 000	3 550	2 040	11,1	C2226-XL
	230	64	760 000	970 000	119 000	3 550	2 040	10,8	C2226-XL-K
	280	93	1 040 000	1 270 000	135 000	2 800	1 710	27,6	C2326-XL
	280	93	1 040 000	1 270 000	135 000	2 800	1 710	26,9	C2326-XL-K
140	210	53	495 000	730 000	88 000	3 650	1 940	6,1	C3028-XL-K
	210	53	495 000	730 000	88 000	3 650	1 940	6,27	C3028-XL
	210	69	760 000	1 220 000	126 000	890	–	8,16	C4028-XL-V
	210	69	760 000	1 220 000	126 000	890	–	7,95	C4028-XL-K30-V
	225	85	1 020 000	1 590 000	157 000	810	–	12,4	C4128-XL-K30-V
	225	85	1 020 000	1 590 000	157 000	810	–	12,7	C4128-XL-V
	250	68	830 000	1 080 000	126 000	3 050	1 750	14,1	C2228-XL
	250	68	830 000	1 080 000	126 000	3 050	1 750	13,7	C2228-XL-K

medias ▶ <https://www.schaeffler.de/std/1E77>

Before ordering, availability for delivery must be checked.

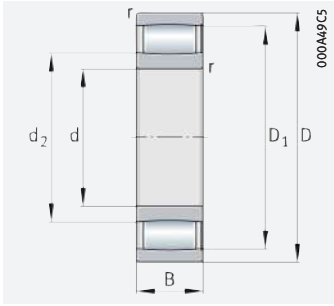

Full complement

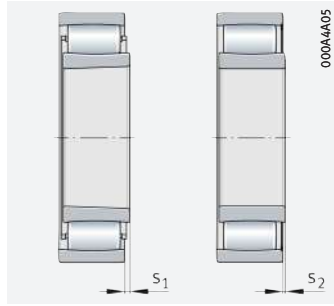

Axial displacement distance

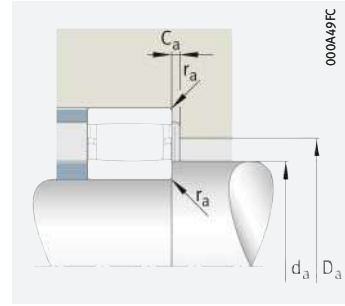

Mounting dimensions

Dimensions						Mounting dimensions						Calculation factors	
d	r	D ₁	d ₂	s ₁	s ₂	D _a		d _a		C _a	r _a	k _{cp}	k _δ
						max.	min.	max.	min.				
120	2	166	138	10,6	3,8	171	–	150	129	–	2	6,176	1,799
	2	166	138	10,6	3,8	171	–	150	129	–	2	6,176	1,799
	2	165,5	137,9	10,6	–	171	161	150	129	1,7	2	6,176	1,799
	2	165,5	137,9	10,6	–	171	161	150	129	1,7	2	6,176	1,799
	2	165,6	141,6	12	5,2	171	–	150	129	–	2	6,421	1,717
	2	165,6	141,6	12	5,2	171	–	150	129	–	2	6,421	1,717
	2	174	142	18	11,2	189	–	160	131	–	2	7,458	1,435
	2	174	142	18	11,2	189	–	160	131	–	2	7,458	1,435
	2,1	190,2	144,8	13	–	203	178	160	132	1,9	2	6,372	1,778
	2,1	190,2	144,8	13	–	203	178	160	132	1,9	2	6,372	1,778
2,1	190	149	17,1	–	203	180	162	132	1,5	2	7,65	1,423	
2,1	190	149	17,1	–	203	180	162	132	1,5	2	7,65	1,423	
130	2	179,9	154,1	16,5	–	191	176	161	139	0,8	2	6,777	1,641
	2	179,9	154,1	16,5	–	191	176	161	139	0,8	2	6,777	1,641
	2	179,8	150,2	11,4	4,6	191	–	165	139	–	2	7,137	1,531
	2	179,8	150,2	11,4	4,6	191	–	165	139	–	2	7,137	1,531
	2	188,4	154,6	18	9,7	199	–	170	141	–	2	7,568	1,437
	2	188,4	154,6	18	9,7	199	–	170	141	–	2	7,568	1,437
	3	199,3	151,7	9,6	–	216	188	167	144	2	2,5	6,983	1,602
	3	199,3	151,7	9,6	–	216	188	167	144	2	2,5	6,983	1,602
	4	236	179	31,2	–	263	–	205	147	2,12	3	9,001	1,216
	4	236	179	31,2	–	263	–	205	147	2,12	3	9,001	1,216
140	2	193,9	163,1	11	–	201	188	172	149	1	2	7,08	1,581
	2	193,9	163,1	11	–	201	188	172	149	1	2	7,08	1,581
	2	191,1	161,5	11,4	5,9	201	–	175	149	–	2	7,235	1,531
	2	191,1	161,5	11,4	5,9	201	–	175	149	–	2	7,235	1,531
	2,1	203,2	166,8	12	5,2	214	–	182	151	–	2	9,241	1,144
	2,1	203,2	166,8	12	5,2	214	–	182	151	–	2	9,241	1,144
	3	221,4	174,6	13,7	–	236	210	190	154	1,9	2,5	7,191	1,598
	3	221,4	174,6	13,7	–	236	210	190	154	1,9	2,5	7,191	1,598





Toroidal roller bearings

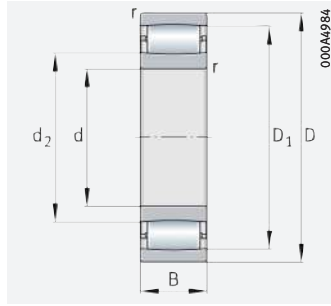

Cylindrical bore

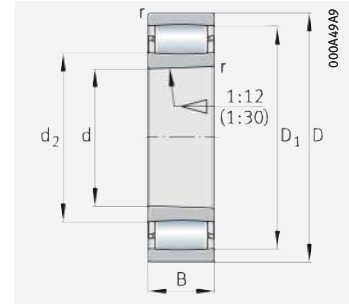

Tapered bore

d = 150 – 170 mm

Main dimensions			Basic load ratings		Fatigue limit load C_{ur} N	Limiting speed n_G min ⁻¹	Speed rating n_{dr} min ⁻¹	Mass m ≈ kg	Designation ► 809 1.12 ► 809 1.13 X-life ► 804
d	D	B	dyn. C_r N	stat. C_{0r} N					
150	225	56	600 000	960 000	114 000	810	–	7,6	C3030-XL-V
	225	56	540 000	850 000	101 000	3 400	1 790	7,4	C3030-XL-K-M1B
	225	56	600 000	960 000	114 000	810	–	7,4	C3030-XL-K-V
	225	56	540 000	850 000	101 000	3 400	1 790	7,6	C3030-XL-M1B
	225	75	780 000	1 320 000	132 000	810	–	9,91	C4030-XL-K30-V
	225	75	780 000	1 320 000	132 000	810	–	10,2	C4030-XL-V
	250	80	920 000	1 310 000	139 000	3 000	1 610	15	C3130-XL-K
	250	80	920 000	1 310 000	139 000	3 000	1 610	15,4	C3130-XL
	250	100	1 240 000	1 880 000	186 000	710	–	18,8	C4130-XL-K30-V
	250	100	1 240 000	1 880 000	186 000	710	–	19,3	C4130-XL-V
	270	73	1 010 000	1 240 000	152 000	2 850	1 680	17,8	C2230-XL
	270	73	1 010 000	1 240 000	152 000	2 850	1 680	17,3	C2230-XL-K
160	240	60	610 000	980 000	116 000	3 150	1 640	9,26	C3032-XL
	240	60	610 000	980 000	116 000	3 150	1 640	9	C3032-XL-K
	240	80	910 000	1 470 000	158 000	740	–	12	C4032-XL-K30-V
	240	80	910 000	1 470 000	158 000	740	–	12,4	C4032-XL-V
	270	86	1 010 000	1 410 000	147 000	2 800	1 550	19,1	C3132-XL-K-M1B
	270	86	1 010 000	1 410 000	147 000	2 800	1 550	19,6	C3132-XL-M1B
	270	109	1 470 000	2 200 000	211 000	630	–	24,2	C4132-XL-K30-V
	270	109	1 470 000	2 200 000	211 000	630	–	24,9	C4132-XL-V
	290	104	1 440 000	1 870 000	224 000	2 550	1 340	29,4	C3232-XL
290	104	1 440 000	1 870 000	224 000	2 550	1 340	28,5	C3232-XL-K	
170	260	67	770 000	1 200 000	114 000	2 850	1 480	12,5	C3034-XL
	260	67	770 000	1 200 000	114 000	2 850	1 480	12,2	C3034-XL-K
	260	90	1 140 000	1 880 000	187 000	650	–	16,4	C4034-XL-K30-V
	260	90	1 140 000	1 880 000	187 000	650	–	16,8	C4034-XL-V
	280	88	1 060 000	1 490 000	154 000	2 650	1 470	20,5	C3134-XL-K
	280	88	1 060 000	1 490 000	154 000	2 650	1 470	21	C3134-XL
	280	109	1 540 000	2 310 000	223 000	580	–	25,4	C4134-XL-K30-V
	280	109	1 540 000	2 310 000	223 000	580	–	26	C4134-XL-V
	310	86	1 310 000	1 630 000	202 000	2 340	1 390	27,9	C2234-XL
	310	86	1 310 000	1 630 000	202 000	2 340	1 390	27,1	C2234-XL-K

medias ► <https://www.schaeffler.de/std/1E78>

Before ordering, availability for delivery must be checked.

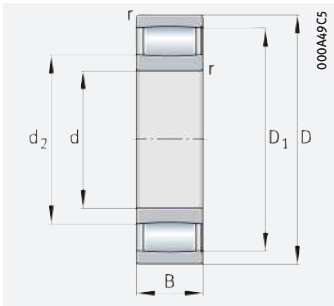

Full complement

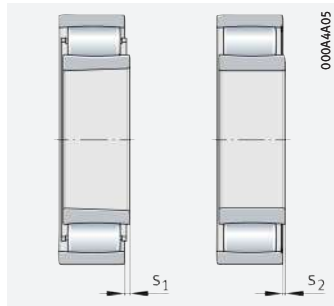

Axial displacement distance

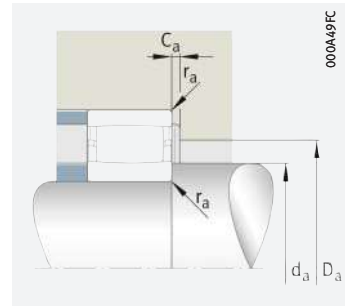

Mounting dimensions

Dimensions						Mounting dimensions						Calculation factors		
d	r	D ₁	d ₂	s ₁	s ₂	D _a		d _a		C _a	r _a	k _φ	k _δ	
						max.	min.	max.	min.					min.
150	2,1	204,1	173,9	14,1	7,3	214	–	187	161	–	2	7,535	1,483	
	2,1	204,1	173,9	8,7	–	214	199	172,2	161	1,16	2	7,535	1,483	
	2,1	204,1	173,9	14,1	7,3	214	–	187	161	–	2	7,535	1,483	
	2,1	204,1	173,9	8,7	–	214	199	172,2	161	1,16	2	7,535	1,483	
	2,1	202,2	173,8	17,4	10,6	214	–	187	161	–	2	7,338	1,531	
	2,1	202,2	173,8	17,4	10,6	214	–	187	161	–	2	7,338	1,531	
	2,1	225,5	182,5	13,9	–	238	215	197	162	0,9	2	9,371	1,15	
	2,1	225,5	182,5	13,9	–	238	215	197	162	0,9	2	9,371	1,15	
	2,1	221,5	179,5	20	10,1	228	–	200	162	–	2	10,222	1,03	
	2,1	221,5	179,5	20	10,1	228	–	200	162	–	2	10,222	1,03	
	3	235,8	177,2	11,2	–	256	220	197	164	2,4	2,5	8,45	1,313	
	3	235,8	177,2	11,2	–	256	220	197	164	2,4	2,5	8,45	1,313	
160	2,1	218,1	186,9	15	–	229	212	196	171	0,8	2	8,127	1,373	
	2,1	218,1	186,9	15	–	229	212	196	171	0,8	2	8,127	1,373	
	2,1	215,7	182,3	18,1	8,2	229	–	200	171	–	2	8,521	1,286	
	2,1	215,7	182,3	18,1	8,2	229	–	200	171	–	2	8,521	1,286	
	2,1	238,2	191,8	10,3	–	258	227	189	172	1,73	2	9,469	1,15	
	2,1	238,2	191,8	10,3	–	258	227	189	172	1,73	2	9,469	1,15	
	2,1	239	192	21	11,1	258	–	215	172	–	2	10,886	0,969	
	2,1	239	192	21	11,1	258	–	215	172	–	2	10,886	0,969	
	3	255,2	194,8	19,3	–	276	239	216	174	2,4	2,5	11,556	0,915	
	3	255,2	194,8	19,3	–	276	239	216	174	2,4	2,5	11,556	0,915	
	170	2,1	236,1	200,9	12,5	–	249	229	211	181	0,9	2	7,129	1,672
		2,1	236,1	200,9	12,5	–	249	229	211	181	0,9	2	7,129	1,672
2,1		233,7	196,3	17,1	7,2	249	–	222	181	–	2	9,496	1,145	
2,1		233,7	196,3	17,1	7,2	249	–	222	181	–	2	9,496	1,145	
2,1		248	201	21	–	268	237	216	182	1,7	2	8,985	1,243	
2,1		248	201	21	–	268	237	216	182	1,7	2	8,985	1,243	
2,1		250,5	200,5	21	11,1	268	–	225	182	–	2	10,948	0,971	
2,1		250,5	200,5	21	11,1	268	–	225	182	–	2	10,948	0,971	
4		273,8	209,2	16,4	–	293	257	231	187	2,6	3	9,647	1,158	
4		273,8	209,2	16,4	–	293	257	231	187	2,6	3	9,647	1,158	





Toroidal roller bearings

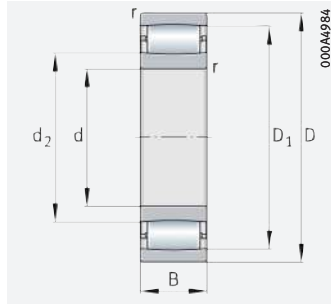

Cylindrical bore

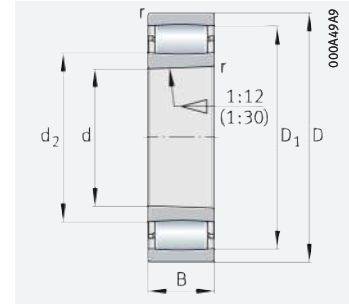

Tapered bore

d = 180 – 200 mm

Main dimensions			Basic load ratings		Fatigue limit load C_{ur} N	Limiting speed n_G min^{-1}	Speed rating $n_{\theta r}$ min^{-1}	Mass m \approx kg	Designation ▶ 809 1.12 ▶ 809 1.13 X-life ▶ 804
d	D	B	dyn. C_r N	stat. C_{0r} N					
180	280	74	900 000	1 360 000	150 000	2 650	1 420	16,4	C3036-XL
	280	74	900 000	1 360 000	150 000	2 650	1 420	16	C3036-XL-K
	280	100	1 330 000	2 140 000	212 000	600	–	21,6	C4036-XL-K30-V
	280	100	1 330 000	2 140 000	212 000	600	–	22,2	C4036-XL-V
	300	96	1 300 000	1 780 000	216 000	2 380	1 310	26	C3136-XL-K
	300	96	1 300 000	1 780 000	216 000	2 380	1 310	26,7	C3136-XL
	300	118	1 780 000	2 700 000	242 000	530	–	31,9	C4136-XL-K30-V
	300	118	1 780 000	2 700 000	242 000	530	–	32,8	C4136-XL-V
	320	112	1 570 000	2 220 000	255 000	2 200	1 110	36,8	C3236-XL-K
	320	112	1 570 000	2 220 000	255 000	2 200	1 110	37,8	C3236-XL
190	290	75	940 000	1 480 000	161 000	2 450	1 280	17,4	C3038-XL
	290	75	940 000	1 480 000	161 000	2 450	1 280	16,9	C3038-XL-K
	290	100	1 370 000	2 330 000	221 000	540	–	22,6	C4038-XL-K30-V
	290	100	1 370 000	2 330 000	221 000	540	–	23,2	C4038-XL-V
	320	104	1 540 000	2 240 000	205 000	2 220	1 160	32,4	C3138-XL-K
	320	104	1 540 000	2 240 000	205 000	2 220	1 160	33,3	C3138-XL
	320	128	2 060 000	3 200 000	270 000	485	–	39,9	C4138-XL-K30-V
	320	128	2 060 000	3 200 000	270 000	485	–	41	C4138-XL-V
	340	92	1 430 000	1 760 000	217 000	2 130	1 310	34,4	C2238-XL
	340	92	1 430 000	1 760 000	217 000	2 130	1 310	35,3	C2238-XL-K
200	310	82	1 170 000	1 760 000	181 000	2 250	1 180	22,2	C3040-XL
	310	82	1 170 000	1 760 000	181 000	2 250	1 180	21,6	C3040-XL-K
	310	109	1 650 000	2 650 000	265 000	490	–	28,7	C4040-XL-K30-V
	310	109	1 650 000	2 650 000	265 000	490	–	29,5	C4040-XL-V
	340	112	1 600 000	2 330 000	265 000	2 060	1 120	39,8	C3140-XL-K
	340	112	1 600 000	2 330 000	265 000	2 060	1 120	40,8	C3140-XL
	340	140	2 400 000	3 700 000	315 000	435	–	49,7	C4140-XL-K30-V
	340	140	2 400 000	3 700 000	365 000	435	–	51,1	C4140-XL-V

medias ▶ <https://www.schaeffler.de/std/1E79>

Before ordering, availability for delivery must be checked.

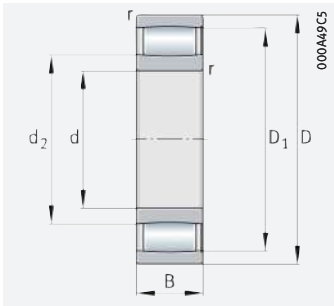

Full complement

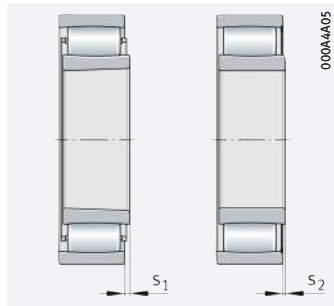

Axial displacement distance

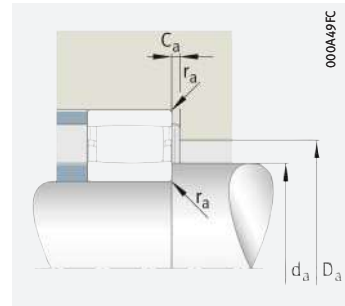

Mounting dimensions

Dimensions						Mounting dimensions						Calculation factors	
d	r	D ₁	d ₂	s ₁	s ₂	D _a		d _a		C _a	r _a	k _φ	k _δ
						max.	min.	max.	min.				
180	2,1	251	208,9	15,1	–	269	241	223	191	1,4	2	9,696	1,136
	2,1	251	208,9	15,1	–	269	241	223	191	1,4	2	9,696	1,136
	2,1	246	204	20,1	10,2	269	–	230	191	–	2	10,427	1,03
	2,1	246	204	20,1	10,2	269	–	230	191	–	2	10,427	1,03
	3	270,8	215,2	23,2	–	286	257	234	194	2,1	2,5	9,634	1,162
	3	270,8	215,2	23,2	–	286	257	234	194	2,1	2,5	9,634	1,162
	3	264	212	20	10,1	286	–	248	194	–	2,5	11,41	0,935
	3	264	212	20	10,1	286	–	248	194	–	2,5	11,41	0,935
	4	288	229	27,3	–	303	274	248	197	2,1	3	11,849	0,915
4	288	229	27,3	–	303	274	248	197	2,1	3	11,849	0,915	
190	2,1	266,5	224,5	16,1	–	279	258	237	201	1,4	2	9,831	1,136
	2,1	266,5	224,5	16,1	–	279	258	237	201	1,4	2	9,831	1,136
	2,1	262,5	220,5	20	10,1	279	–	240	201	–	2	10,571	1,03
	2,1	262,5	220,5	20	10,1	279	–	240	201	–	2	10,571	1,03
	3	288,7	228,3	19	–	306	274	248	204	2,3	2,5	11,767	0,918
	3	288,7	228,3	19	–	306	274	249	204	2,3	2,5	11,767	0,918
	3	280,5	225,5	20	10,1	306	–	255	204	–	2,5	12,252	0,868
	3	280,5	225,5	20	10,1	306	–	255	204	–	2,5	12,252	0,868
	4	296	223,2	22,5	–	323	275	250	207	3	3	9,695	1,176
4	296	223,2	22,5	–	323	275	250	207	3	3	9,695	1,176	
200	2,1	285,2	234,8	15,2	–	299	272	252	211	1,6	2	10,083	1,117
	2,1	285,2	234,8	15,2	–	299	272	252	211	1,6	2	10,083	1,117
	2,1	278,6	230,4	21	11,1	299	–	255	211	–	2	11,664	0,924
	2,1	278,6	230,4	21	11,1	299	–	255	211	–	2	11,664	0,924
	3	304,4	245,6	27,3	–	326	290	265	214	2,1	2,5	11,861	0,923
	3	304,4	245,6	27,3	–	326	290	265	214	2,1	2,5	11,861	0,923
	3	300,6	238,4	22	12,1	326	–	270	214	–	2,5	14,02	0,747
	3	300,5	238,5	22	12,1	326	–	270	214	–	2,5	13,961	0,752





Toroidal roller bearings

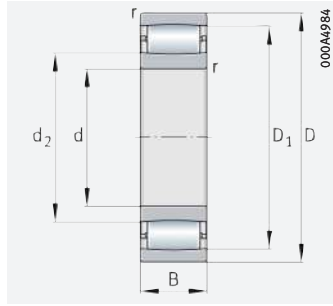

Cylindrical bore

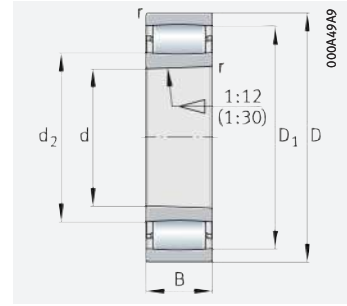

Tapered bore

d = 220 – 300 mm

Main dimensions			Basic load ratings		Fatigue limit load C_{ur} N	Limiting speed n_G min^{-1}	Speed rating $n_{\vartheta r}$ min^{-1}	Mass m ≈ kg	Designation ► 809 1.12 ► 809 1.13 X-life ► 804
d	D	B	dyn. C_r N	stat. C_{Or} N					
220	340	90	1 370 000	2 130 000	221 000	2 030	1 050	28,4	C3044-XL-K
	340	90	1 370 000	2 130 000	221 000	2 030	1 050	29,2	C3044-XL
	340	118	1 960 000	3 250 000	285 000	425	–	37,3	C4044-XL-K30-V
	340	118	1 960 000	3 250 000	285 000	425	–	38,3	C4044-XL-V
	370	120	1 930 000	2 900 000	280 000	1 850	960	49,9	C3144-XL-K
	370	120	1 930 000	2 900 000	280 000	1 850	960	51,3	C3144-XL
	400	108	2 080 000	2 550 000	300 000	1 720	1 050	58,2	C2244-XL
	400	108	2 080 000	2 550 000	300 000	1 720	1 050	56,7	C2244-XL-K
240	360	92	1 400 000	2 230 000	228 000	1 880	980	31,1	C3048-XL-K
	360	92	1 400 000	2 230 000	228 000	1 880	980	32	C3048-XL
	400	128	2 380 000	3 500 000	370 000	1 690	870	61,6	C3148-XL-K
	400	128	2 380 000	3 500 000	370 000	1 690	870	63,2	C3148-XL
260	400	104	1 830 000	2 950 000	280 000	1 650	830	45,2	C3052-XL-K
	400	104	1 830 000	2 950 000	280 000	1 650	830	46,4	C3052-XL
	440	144	2 750 000	4 250 000	435 000	1 480	740	85,3	C3152-XL-K
	440	144	2 750 000	4 250 000	435 000	1 480	740	87,5	C3152-XL
280	420	106	1 870 000	3 100 000	290 000	1 530	770	48,8	C3056-XL-K
	420	106	1 870 000	3 100 000	290 000	1 530	770	50,1	C3056-XL
	460	146	2 850 000	4 500 000	455 000	1 400	700	93,8	C3156-XL
	460	146	2 850 000	4 500 000	455 000	1 400	700	91,4	C3156-XL-K
300	460	118	2 220 000	3 800 000	330 000	1 400	690	67,4	C3060-XL-K-M
	460	118	2 220 000	3 800 000	330 000	1 400	690	69,2	C3060-XL-M
	460	160	2 650 000	4 550 000	420 000	1 440	600	91,4	C4060-XL-K30-M1B
	460	160	2 650 000	4 550 000	420 000	1 440	600	93,9	C4060-XL-M1B
	500	160	3 350 000	5 300 000	510 000	1 280	630	120	C3160-XL-K
	500	160	3 350 000	5 300 000	510 000	1 280	630	124	C3160-XL
	500	200	4 150 000	6 800 000	670 000	1 280	495	150	C4160-XL-K30-M1B
	500	200	4 150 000	6 800 000	670 000	1 280	495	154	C4160-XL-M1B

medias ► <https://www.schaeffler.de/std/1E7A>

Before ordering, availability for delivery must be checked.

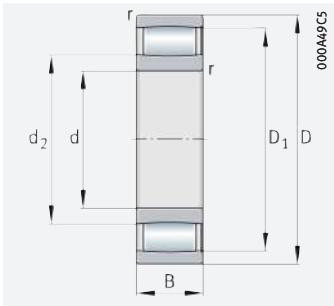

Full complement

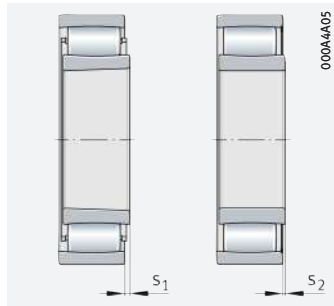

Axial displacement distance

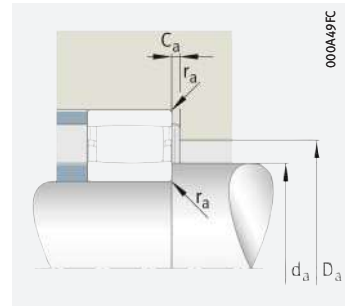

Mounting dimensions

Dimensions						Mounting dimensions						Calculation factors	
d	r	D ₁	d ₂	s ₁	s ₂	D _a		d _a		C _a	r _a	k _φ	k _δ
		min. ≈	≈	max.	min.	max.	min.	min.	max.				
220	3	310	256,7	17,2	–	327	297	274	233	1,7	2,5	11,851	0,931
	3	310	256,7	17,2	–	327	297	274	233	1,7	2,5	11,851	0,931
	3	304,1	252,9	20	10,1	327	–	280	233	–	2,5	11,548	0,957
	3	304,1	252,9	20	10,1	327	–	280	233	–	2,5	11,548	0,957
	4	333,1	269,2	22,3	–	353	316	291	237	1,4	3	13,667	0,791
	4	333,1	269,2	22,3	–	353	316	291	237	1,4	3	13,667	0,791
	4	351,1	257,9	20,5	–	383	323	292	237	3,9	3	11,976	0,937
	4	351,1	257,9	20,5	–	383	323	292	237	3,9	3	11,976	0,937
240	3	329,2	275,8	19,2	–	347	316	293	253	1,7	2,5	12,016	0,931
	3	329,2	275,8	19,2	–	347	316	293	253	1,7	2,5	12,016	0,931
	4	365,8	281,2	20,4	–	383	337	307	257	2,9	3	14,559	0,741
	4	356,8	281,2	20,4	–	383	337	307	257	2,9	3	14,559	0,741
260	4	366,1	305,8	19,3	–	385	351	326	275	1,9	3	12,381	0,924
	4	366,1	305,8	19,3	–	385	351	326	275	1,9	3	12,381	0,924
	4	397	318,9	26,4	–	423	377	346	277	1,7	3	16,223	0,667
	4	397	318,9	26,4	–	423	377	346	277	1,7	3	16,223	0,667
280	4	388,5	328,5	21,3	–	405	374	348	295	1,9	3	12,577	0,924
	4	388,5	328,5	21,3	–	405	374	348	295	1,9	3	12,577	0,924
	5	415	337	28,4	–	440	394	364	300	1,7	4	16,385	0,666
	5	415	337	28,4	–	440	394	364	300	1,7	4	16,385	0,666
300	4	416	353	20	–	445	400	369	315	1,6	3	14,109	0,812
	4	416	353	20	–	445	400	369	315	1,6	3	14,109	0,812
	4	404,8	343,2	16	–	445	392	357	315	0,71	3	16,395	0,665
	4	404,8	343,2	16	–	445	392	357	315	0,71	3	16,395	0,665
	5	447,6	362,4	30,5	–	480	426	391	320	1,9	4	17,019	0,647
	5	447,6	362,4	30,5	–	480	426	391	320	1,9	4	17,019	0,647
	5	446,1	355,9	14,9	–	480	425	352	320	4,2	4	27,776	0,359
	5	446,1	355,9	14,9	–	480	425	352	320	4,2	4	27,776	0,359





Toroidal roller bearings

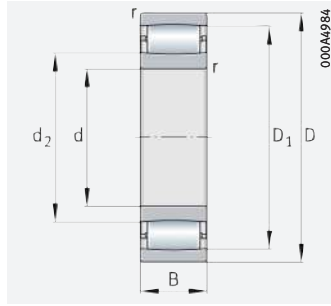

Cylindrical bore

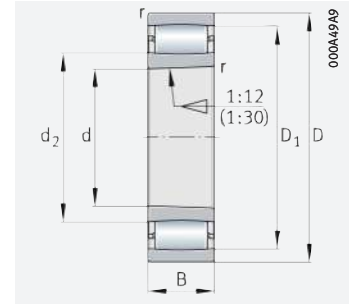

Tapered bore

d = 320 – 420 mm

Main dimensions			Basic load ratings		Fatigue limit load C_{Ur} N	Limiting speed n_G min^{-1}	Speed rating $n_{\theta r}$ min^{-1}	Mass m \approx kg	Designation ▶ 809 1.12 ▶ 809 1.13 X-life ▶ 804
d	D	B	dyn. C_r N	stat. C_{Or} N					
320	480	121	2 300 000	4 100 000	365 000	1 310	640	74,7	C3064-XL-M
	480	121	2 300 000	4 100 000	365 000	1 310	640	72,8	C3064-XL-K-M
	540	176	4 150 000	6 300 000	610 000	1 180	590	157	C3164-XL-M
	540	176	4 150 000	6 300 000	610 000	1 180	590	157	C3164-XL-K-M
340	520	133	2 950 000	4 950 000	460 000	1 170	560	99,3	C3068-XL-M
	520	133	2 950 000	4 950 000	460 000	1 170	560	96,8	C3068-XL-K-M
	580	190	4 900 000	7 500 000	710 000	1 060	510	202	C3168-XL-M
	580	190	4 900 000	7 500 000	710 000	1 060	510	197	C3168-XL-K-M
360	480	90	1 770 000	3 250 000	360 000	1 280	600	42,6	C3972-XL-K-M
	480	90	1 770 000	3 250 000	360 000	1 280	600	43,8	C3972-XL-M
	540	134	2 950 000	5 000 000	460 000	1 120	550	105	C3072-XL-M
	540	134	2 950 000	5 000 000	460 000	1 120	550	102	C3072-XL-K-M
	600	192	5 100 000	8 000 000	750 000	1 020	485	213	C3172-XL-M
	600	192	5 100 000	8 000 000	750 000	1 020	485	208	C3172-XL-K-M
380	520	106	2 130 000	4 000 000	405 000	1 150	550	62,8	C3976-XL-K-M
	520	106	2 130 000	4 000 000	405 000	1 150	550	64,4	C3976-XL-M
	560	135	3 050 000	5 200 000	475 000	1 090	530	110	C3076-XL-M
	560	135	3 050 000	5 200 000	475 000	1 090	530	107	C3076-XL-K-M
	620	194	5 000 000	8 500 000	720 000	990	455	225	C3176-XL-M
	620	194	5 000 000	8 500 000	720 000	990	455	219	C3176-XL-K-M
400	540	106	2 170 000	4 150 000	415 000	1 120	530	65,6	C3980-XL-K-M
	540	106	2 170 000	4 150 000	415 000	1 120	530	67,3	C3980-XL-M
	600	148	3 750 000	6 200 000	560 000	980	475	143	C3080-XL-M
	600	148	3 750 000	6 200 000	560 000	980	475	139	C3080-XL-K-M
	650	200	4 800 000	8 300 000	750 000	910	435	253	C3180-XL-M
	650	200	4 800 000	8 300 000	750 000	910	435	247	C3180-XL-K-M
	650	200	4 800 000	8 300 000	750 000	910	435	247	C3180-XL-K-M
420	560	106	2 200 000	4 250 000	425 000	1 070	510	68,4	C3984-XL-K-M
	560	106	2 200 000	4 250 000	425 000	1 070	510	70,2	C3984-XL-M
	620	150	3 800 000	6 400 000	580 000	950	460	151	C3084-XL-M
	620	150	3 800 000	6 400 000	580 000	950	460	147	C3084-XL-K-M
	700	224	6 000 000	10 600 000	890 000	860	390	339	C3184-XL-M
	700	224	6 000 000	10 600 000	890 000	860	390	330	C3184-XL-K-M

medias ▶ <https://www.schaeffler.de/std/1E7B>

Before ordering, availability for delivery must be checked.

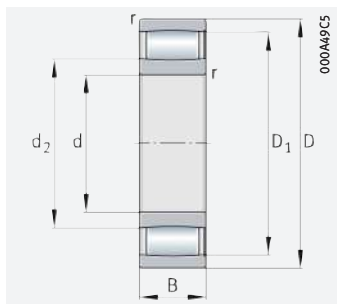

Full complement

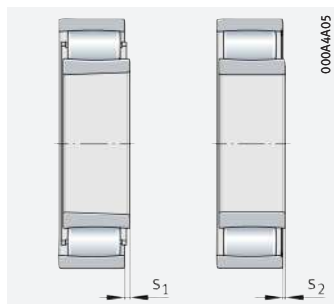

Axial displacement distance

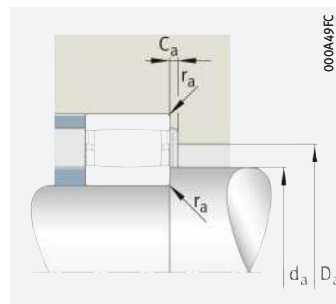

Mounting dimensions

Dimensions						Mounting dimensions						Calculation factors	
d	r	D ₁	d ₂	s ₁	s ₂	D _a		d _a		C _a	r _a	k _φ	k _δ
		min. ≈	≈			max.	min.	max.	min.				
320	4	439,4	376,6	23,3	–	465	423	393	335	1,6	3	15,05	0,76
	4	439,4	376,6	23,3	–	465	423	393	335	1,6	3	15,05	0,76
	5	475,9	372,1	26,7	–	520	448	400	340	4	4	19,823	0,542
	5	475,9	372,1	26,7	–	520	448	400	340	4	4	19,823	0,542
340	5	481,7	402,3	25,4	–	502	460	424	358	2,5	4	15,578	0,745
	5	481,7	402,3	25,4	–	502	460	424	358	2,5	4	15,578	0,745
	5	517,6	404,4	25,9	–	560	485	437	360	2,7	4	22,159	0,481
	5	517,6	404,4	25,9	–	560	485	437	360	2,7	4	22,159	0,481
360	3	450,6	393,4	17,2	–	467	437	408	373	2,1	2,5	13,126	0,925
	3	450,6	393,4	17,2	–	467	437	408	373	2,1	2,5	13,126	0,925
	5	496,6	417,4	26,4	–	522	475	439	378	2,5	4	15,709	0,745
	5	496,6	417,4	26,4	–	522	475	439	378	2,5	4	15,709	0,745
	5	542,7	427,2	27,9	–	580	509	461	380	2,7	4	25,896	0,403
5	542,7	427,2	27,9	–	580	509	461	380	2,7	4	25,896	0,403	
380	4	489,1	427,9	21	–	505	474	444	395	2,2	3	14,746	0,813
	4	489,1	427,9	21	–	505	474	444	395	2,2	3	14,746	0,813
	5	510,5	431,5	27	–	542	489	453	398	2,5	4	15,827	0,745
	5	510,5	431,5	27	–	542	489	453	398	2,5	4	15,827	0,745
	5	548,6	448,4	25,4	–	600	523	474	400	2,1	4	20,403	0,544
5	548,6	448,4	25,4	–	600	523	474	400	2,1	4	20,403	0,544	
400	4	500,6	439,4	21	–	525	485	456	415	2,2	3	14,846	0,813
	4	500,6	439,4	21	–	525	485	456	415	2,2	3	14,846	0,813
	5	553	458	30,6	–	582	527	484	418	3	4	17,429	0,671
	5	553	458	30,6	–	582	527	484	418	3	4	17,429	0,671
	6	586,1	490,9	50,7	–	624	563	514	426	1,8	5	20,809	0,542
	6	586,1	490,9	50,7	–	624	563	514	426	1,8	5	20,809	0,542
420	4	518,6	457,4	21,3	–	545	503	474	435	2,2	3	15,003	0,813
	4	518,6	457,4	21,3	–	545	503	474	435	2,2	3	15,003	0,813
	5	569,8	475,2	32,6	–	602	544	501	438	3	4	17,577	0,671
	5	569,8	475,2	32,6	–	602	544	501	438	3	4	17,577	0,671
	6	615,7	510,3	34,8	–	674	587	539	446	1,9	5	24,992	0,435
	6	615,7	510,3	34,8	–	674	587	539	446	1,9	5	24,992	0,435





Toroidal roller bearings

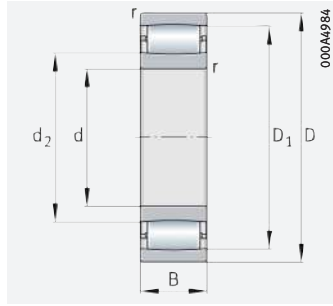

Cylindrical bore

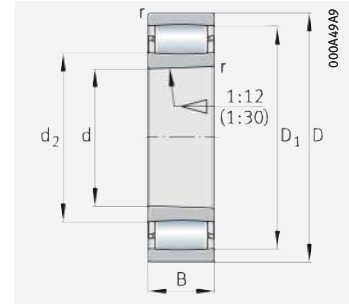

Tapered bore

d = 440 – 500 mm

Main dimensions			Basic load ratings		Fatigue limit load	Limiting speed	Speed rating	Mass	Designation ▶ 809 1.12 ▶ 809 1.13 X-life ▶ 804
d	D	B	dyn. C _r N	stat. C _{0r} N					
440	600	118	2 650 000	5 300 000	490 000	970	445	92,3	C3988-XL-K-M
	600	118	2 650 000	5 300 000	490 000	970	445	94,7	C3988-XL-M
	650	157	3 750 000	6 500 000	570 000	920	460	169	C3088-XL-K-M1B
	650	157	3 750 000	6 500 000	570 000	920	460	173	C3088-XL-M1B
	720	226	6 900 000	11 600 000	960 000	810	360	345	C3188-XL-K-M1B
	720	226	6 900 000	11 600 000	960 000	810	360	354	C3188-XL-M1B
	720	280	7 600 000	12 900 000	1 060 000	820	305	427	C4188-XL-K30-M1B
	720	280	7 600 000	12 900 000	1 060 000	820	305	439	C4188-XL-M1B
460	620	118	2 750 000	5 600 000	510 000	940	425	95,8	C3992-XL-K-M
	620	118	2 750 000	5 600 000	510 000	940	425	98,4	C3992-XL-M
	680	163	4 000 000	7 500 000	640 000	850	400	197	C3092-XL-M
	680	163	4 000 000	7 500 000	640 000	850	400	192	C3092-XL-K-M
	760	240	6 800 000	12 000 000	1 010 000	760	350	424	C3192-XL-M
	760	240	6 800 000	12 000 000	1 010 000	760	350	413	C3192-XL-K-M
	760	300	8 700 000	14 900 000	1 190 000	770	280	516	C4192-XL-K30-M1B
	760	300	8 700 000	14 900 000	1 190 000	770	280	530	C4192-XL-M1B
480	650	128	3 300 000	6 200 000	610 000	880	405	116	C3996-XL-K-M
	650	128	3 300 000	6 200 000	610 000	880	405	119	C3996-XL-M
	700	165	4 100 000	7 800 000	660 000	820	390	207	C3096-XL-M
	700	165	4 100 000	7 800 000	660 000	820	390	201	C3096-XL-K-M
	790	248	7 100 000	12 600 000	1 050 000	730	335	459	C3196-XL-K-M1B
	790	248	7 100 000	12 600 000	1 050 000	730	335	471	C3196-XL-M1B
500	670	128	3 350 000	6 500 000	620 000	830	375	120	C39/500-XL-K-M
	670	128	3 350 000	6 500 000	620 000	830	375	123	C39/500-XL-M
	720	167	4 300 000	8 300 000	700 000	790	370	216	C30/500-XL-M
	720	167	4 300 000	8 300 000	700 000	790	370	211	C30/500-XL-K-M
	830	264	7 500 000	12 900 000	1 090 000	680	330	545	C31/500-XL-K-M
	830	264	7 500 000	12 900 000	1 090 000	680	330	559	C31/500-XL-M
	830	325	10 700 000	19 100 000	1 410 000	680	225	670	C41/500-XL-K30-M1B
	830	325	10 700 000	19 100 000	1 410 000	680	225	688	C41/500-XL-M1B

medias ▶ <https://www.schaeffler.de/std/1E7C>

Before ordering, availability for delivery must be checked.

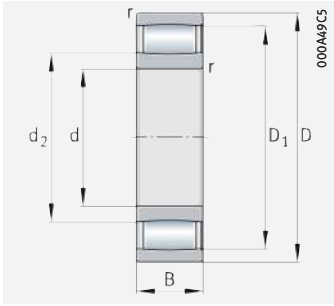

Full complement

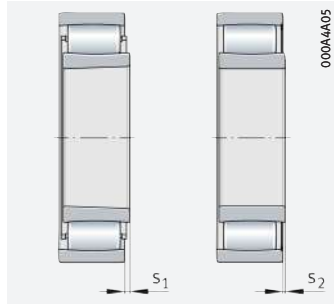

Axial displacement distance

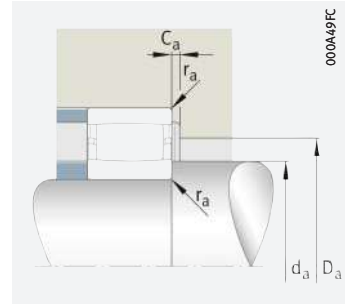

Mounting dimensions

Dimensions						Mounting dimensions						Calculation factors	
d	r	D ₁	d ₂	s ₁	s ₂	D _a		d _a		C _a	r _a	k _φ	k _δ
						max.	min.	max.	min.				
440	4	559,5	494,5	20	–	585	545	517	455	1,4	3	16,524	0,732
	4	559,5	494,5	20	–	585	545	517	455	1,4	3	16,524	0,732
	6	583,7	491,9	19,7	–	627	566	489	463	5,5	5	18,096	0,652
	6	583,7	494,3	19,7	–	627	566	489	463	5,5	5	18,096	0,652
	6	646,2	521,1	16	–	694	615	518	466	6,3	5	25,092	0,347
	6	646,2	521,1	16	–	694	615	518	466	6,3	5	25,092	0,347
	6	634,4	512,6	27,8	–	694	608	506	466	6,5	5	29,46	0,357
	6	634,4	512,6	27,8	–	694	608	506	466	6,5	5	29,46	0,357
460	4	574	509	20	–	605	561	504	467	1,4	3	16,651	0,732
	4	574	509	20	–	605	561	504	467	1,4	3	16,651	0,732
	6	623,7	539,2	33,5	–	654	603	560	486	2,2	5	18,559	0,647
	6	623,7	539,2	33,5	–	654	603	560	486	2,2	5	18,559	0,647
	7,5	679,2	558,8	51	–	728	649	589	492	2,1	6	25,204	0,441
	7,5	679,2	558,8	51	–	728	649	589	492	2,1	6	25,204	0,441
	7,5	668,3	539,6	23,3	–	728	634	588	477	6,9	6	32,219	0,324
	7,5	668,3	539,6	23,3	–	728	634	588	477	6,9	6	32,219	0,324
480	5	607,6	525,4	20,4	–	632	588	555	498	3,1	4	19,501	0,6
	5	607,6	525,4	20,4	–	632	588	555	498	3,1	4	19,501	0,6
	6	639,5	555,5	35,5	–	677	619	576	503	2,2	5	18,699	0,647
	6	639,5	555,5	35,5	–	677	619	576	503	2,2	5	18,699	0,647
	7,5	697,4	577,1	35,1	–	758	676	574	512	6,1	6	25,47	0,439
	7,5	697,4	577,1	35,1	–	758	676	574	512	6,1	6	25,47	0,439
500	5	634,6	552,4	20,4	–	652	615	573	518	3,1	4	19,736	0,6
	5	634,6	552,4	20,4	–	652	615	573	518	3,1	4	19,736	0,6
	6	655,8	572,2	37,5	–	697	635	593	523	2,1	5	18,843	0,647
	6	655,8	572,2	37,5	–	697	635	593	523	2,1	5	18,843	0,647
	7,5	734,2	608,8	75,3	–	798	702	641	532	4,4	6	25,64	0,441
	7,5	734,2	608,8	75,3	–	798	702	641	532	4,4	6	25,64	0,441
	7,5	739,2	598,7	15	–	798	708	594	532	7,5	6	36,213	0,287
	7,5	739,2	598,7	15	–	798	708	594	532	7,5	6	36,213	0,287





Toroidal roller bearings

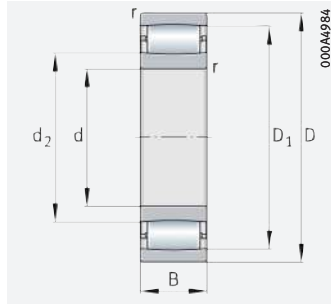

Cylindrical bore

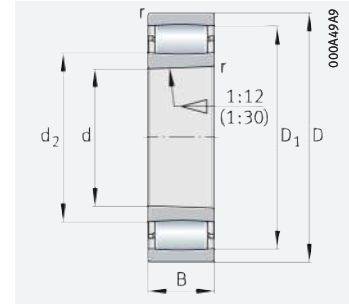

Tapered bore

d = 530 – 670 mm

Main dimensions			Basic load ratings		Fatigue limit load	Limiting speed	Speed rating	Mass	Designation
d	D	B	dyn. C _r N	stat. C _{0r} N	C _{ur} N	n _G min ⁻¹	n _{Dr} min ⁻¹	m ≈ kg	▶ 809 1.12 ▶ 809 1.13 X-life ▶ 804
530	710	136	3 550 000	7 100 000	670 000	790	365	143	C39/530-XL-K-M
	710	136	3 550 000	7 100 000	670 000	790	365	146	C39/530-XL-M
	780	185	5 200 000	9 700 000	790 000	730	340	292	C30/530-XL-M
	780	185	5 200 000	9 700 000	790 000	730	340	285	C30/530-XL-K-M
	870	272	9 100 000	16 100 000	1 310 000	640	280	625	C31/530-XL-M
	870	272	9 100 000	16 100 000	1 310 000	640	280	609	C31/530-XL-K-M
560	750	140	3 650 000	7 500 000	700 000	730	335	164	C39/560-XL-K-M
	750	140	3 650 000	7 500 000	700 000	730	335	168	C39/560-XL-M
	820	195	5 700 000	11 200 000	890 000	660	295	338	C30/560-XL-M
	820	195	5 700 000	11 200 000	890 000	660	295	329	C30/560-XL-K-M
	920	280	9 600 000	17 400 000	1 350 000	610	265	701	C31/560-XL-K-M1B
	920	280	9 600 000	17 400 000	1 350 000	610	265	720	C31/560-XL-M1B
600	800	150	4 100 000	8 800 000	790 000	680	305	197	C39/600-XL-K-M
	800	150	4 100 000	8 800 000	790 000	680	305	203	C39/600-XL-M
	870	200	6 300 000	12 200 000	970 000	620	275	383	C30/600-XL-M
	870	200	6 300 000	12 200 000	970 000	620	275	373	C30/600-XL-K-M
	980	300	11 100 000	19 100 000	1 490 000	550	247	847	C31/600-XL-K-M1B
	980	300	11 100 000	19 100 000	1 490 000	550	247	869	C31/600-XL-M1B
	980	375	13 600 000	24 500 000	1 780 000	560	186	1 058	C41/600-XL-K30-M1B
	980	375	13 600 000	24 500 000	1 780 000	560	186	1 086	C41/600-XL-M1B
630	850	165	5 000 000	10 100 000	890 000	630	285	253	C39/630-XL-K-M
	850	165	5 000 000	10 100 000	890 000	630	285	259	C39/630-XL-M
	920	212	6 900 000	12 900 000	1 050 000	580	270	460	C30/630-XL-M
	920	212	6 900 000	12 900 000	1 050 000	580	270	448	C30/630-XL-K-M
	1 030	315	12 200 000	22 000 000	1 660 000	520	222	983	C31/630-XL-K-M1B
	1 030	315	12 200 000	22 000 000	1 660 000	520	222	1 009	C31/630-XL-M1B
670	900	170	5 700 000	12 300 000	1 020 000	570	237	289	C39/670-XL-K-M
	900	170	5 700 000	12 300 000	1 020 000	570	237	296	C39/670-XL-M
	980	230	8 300 000	16 500 000	1 250 000	530	226	568	C30/670-XL-M
	980	230	8 300 000	16 500 000	1 250 000	530	226	553	C30/670-XL-K-M
	1 090	336	12 600 000	22 300 000	1 740 000	490	220	1 167	C31/670-XL-K-M1B
	1 090	336	12 600 000	22 300 000	1 740 000	490	220	1 198	C31/670-XL-M1B

medias ▶ <https://www.schaeffler.de/std/1E7D>

Before ordering, availability for delivery must be checked.

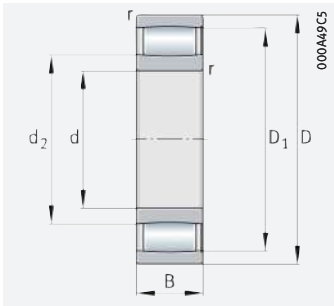

Full complement

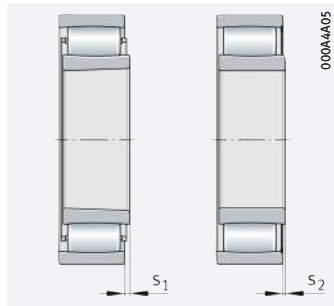

Axial displacement distance

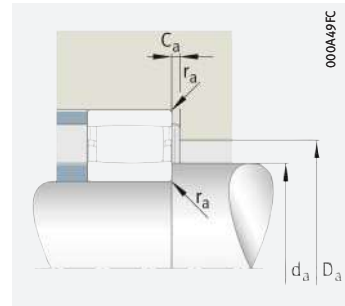

Mounting dimensions

Dimensions						Mounting dimensions						Calculation factors	
d	r	D ₁	d ₂	s ₁	s ₂	D _a		d _a		C _a	r _a	k _φ	k _δ
						max.	min.	max.	min.				
530	5	658	577	28,4	–	692	639	606	548	2,9	4	19,946	0,6
	5	658	577	28,4	–	692	639	606	548	2,9	4	19,946	0,6
	6	702,9	602,1	35,7	–	757	677	628	553	2,5	5	21,626	0,548
	6	702,9	602,1	35,7	–	757	677	628	553	2,5	5	21,626	0,548
	7,5	779,2	636,8	44,4	–	838	738	678	562	3	6	30,734	0,356
	7,5	779,2	636,8	44,4	–	838	738	678	562	3	6	30,734	0,356
560	5	701,7	621,3	32,4	–	732	683	650	578	2,9	4	20,33	0,6
	5	701,7	621,3	32,4	–	732	683	650	578	2,9	4	20,33	0,6
	6	758,9	662,1	45,7	–	793	735	686	583	2,4	5	22,141	0,548
	6	758,9	662,1	45,7	–	793	735	686	583	2,4	5	22,141	0,548
	7,5	805,2	663,4	28	–	888	778	660	592	7,3	6	30,983	0,355
	7,5	805,2	663,4	28	–	888	778	660	592	7,3	6	30,983	0,355
600	5	745,3	664,7	32,4	–	782	726	685	618	1,7	4	21,712	0,561
	5	745,3	664,7	32,4	–	782	726	685	618	1,7	4	21,712	0,561
	6	805,6	691,4	35,9	–	847	773	724	623	2	5	28,196	0,403
	6	805,6	691,4	35,9	–	847	773	724	623	2	5	28,196	0,403
	7,5	869,9	702,9	26,1	–	948	837	699	632	8,8	6	30,953	0,363
	7,5	869,9	702,9	26,1	–	948	837	699	632	8,8	6	30,953	0,363
	7,5	864,7	701,2	24,6	–	948	828	695	632	9	6	40,44	0,26
	7,5	864,7	701,2	24,6	–	948	828	695	632	9	6	40,44	0,26
630	6	790,8	693,2	35,5	–	827	766	729	653	3,6	5	22,766	0,536
	6	790,8	693,2	35,5	–	827	766	729	653	3,6	5	22,766	0,536
	7,5	841,7	715,2	48,1	–	892	809	748	658	3,9	6	29,154	0,39
	7,5	841,7	715,2	48,1	–	892	809	748	658	3,9	6	29,154	0,39
	7,5	910,9	743,4	23,8	–	998	878	739	662	8,8	6	34,168	0,324
	7,5	910,9	743,4	23,8	–	998	878	739	662	8,8	6	34,168	0,324
670	6	852,8	756,2	24,9	–	877	833	749	693	2,1	5	24,732	0,493
	6	852,8	756,2	24,9	–	877	833	749	693	2,1	5	24,732	0,493
	7,5	902,3	776,7	41,1	–	952	870	809	698	3,1	6	27,163	0,44
	7,5	902,3	776,7	41,1	–	952	870	809	698	3,1	6	27,163	0,44
	7,5	963,7	786	41	–	1058	930	782	702	12	6	34,543	0,325
	7,5	963,7	786	41	–	1058	930	782	702	12	6	34,543	0,325





Toroidal roller bearings

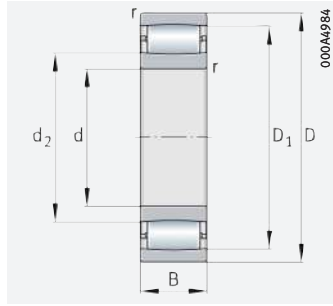

Cylindrical bore

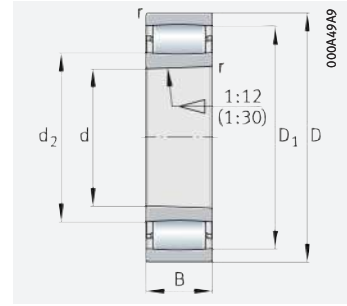

Tapered bore

d = 710 – 900 mm

Main dimensions			Basic load ratings		Fatigue limit load C_{Ur} N	Limiting speed n_G min^{-1}	Speed rating n_{Dr} min^{-1}	Mass m \approx kg	Designation ▶ 809 1.12 ▶ 809 1.13 X-life ▶ 804
d	D	B	dyn. C_r N	stat. C_{Or} N					
710	950	180	6 100 000	12 900 000	1 040 000	550	237	337	C39/710-XL-K-M
	950	180	6 100 000	12 900 000	1 040 000	550	237	346	C39/710-XL-M
	1 030	236	9 000 000	17 600 000	1 360 000	500	214	634	C30/710-XL-M
	1 030	236	9 000 000	17 600 000	1 360 000	500	214	618	C30/710-XL-K-M
	1 030	315	10 300 000	21 100 000	1 560 000	510	176	824	C40/710-XL-K30-M1B
	1 030	315	10 300 000	21 100 000	1 560 000	510	176	846	C40/710-XL-M1B
	1 150	345	12 700 000	24 200 000	1 810 000	465	203	1 327	C31/710-XL-K-M1B
	1 150	345	12 700 000	24 200 000	1 810 000	465	203	1 362	C31/710-XL-M1B
750	1 000	185	6 400 000	14 000 000	1 120 000	510	216	380	C39/750-XL-K-M
	1 000	185	6 400 000	14 000 000	1 120 000	510	216	391	C39/750-XL-M
	1 090	250	9 500 000	19 300 000	1 430 000	475	201	735	C30/750-XL-K-M1B
	1 090	250	9 500 000	19 300 000	1 430 000	475	201	755	C30/750-XL-M1B
800	1 060	195	6 600 000	14 800 000	1 160 000	475	205	443	C39/800-XL-K-M
	1 060	195	6 600 000	14 800 000	1 160 000	475	205	455	C39/800-XL-M
	1 150	258	9 600 000	20 100 000	1 470 000	445	191	828	C30/800-XL-K-M1B
	1 150	258	9 600 000	20 100 000	1 470 000	445	191	828	C30/800-XL-M1B
850	1 120	200	7 800 000	17 000 000	1 390 000	440	182	500	C39/850-XL-K-M
	1 120	200	7 800 000	17 000 000	1 390 000	440	182	513	C39/850-XL-M
900	1 180	206	9 000 000	20 300 000	1 570 000	410	159	564	C39/900-XL-K-M
	1 180	206	9 000 000	20 300 000	1 570 000	410	159	579	C39/900-XL-M

medias ▶ <https://www.schaeffler.de/std/1E7E>

Before ordering, availability for delivery must be checked.

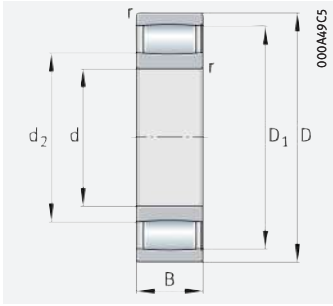

Full complement

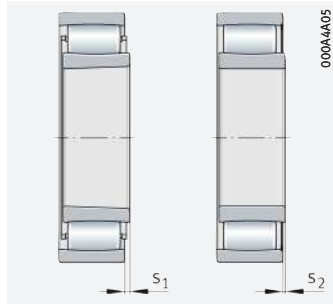

Axial displacement distance

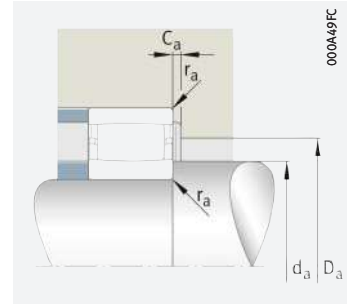

Mounting dimensions

Dimensions						Mounting dimensions						Calculation factors	
d	r	D ₁	d ₂	s ₁	s ₂	D _a		d _a		C _a	r _a	k _φ	k _δ
						max.	min.	max.	min.				
710	6	877,4	772,6	30,7	–	927	849	802	733	6,5	5	25,417	0,479
	6	877,4	772,6	30,7	–	927	849	802	733	6,5	5	25,417	0,479
	7,5	943,3	808,7	47,3	–	1002	906	846	738	4,3	6	27,717	0,435
	7,5	943,3	808,7	47,3	–	1002	906	846	738	4,3	6	27,717	0,435
	7,5	931,2	806,8	31,5	–	1002	899	841	738	1,3	6	34,772	0,321
	7,5	931,2	806,8	31,5	–	1002	899	841	738	1,3	6	34,772	0,321
	9,5	1005,3	843,3	47,8	–	1100	976	839	750	8,7	8	35,044	0,324
	9,5	1005,3	843,3	47,8	–	1100	976	839	750	8,7	8	35,044	0,324
750	6	933,5	829,5	35,7	–	977	906	869	773	3,8	5	25,91	0,479
	6	933,5	829,5	35,7	–	977	906	869	773	3,8	5	25,91	0,479
	7,5	991,7	856,3	25	–	1062	965	852	778	6,9	6	29,669	0,404
	7,5	991,7	856,3	25	–	1062	965	852	778	6,9	6	29,669	0,404
800	6	990,6	888,4	45,7	–	1037	970	879	823	3,6	5	26,416	0,479
	6	990,6	888,4	45,7	–	1037	970	879	823	3,6	5	26,416	0,479
	7,5	1045,4	911,5	25	–	1122	1020	906	828	6,9	6	30,144	0,404
	7,5	1045,4	911,5	25	–	1122	1020	906	828	6,9	6	30,144	0,404
850	6	1056,9	936,1	35,9	–	1097	1027	981	873	4,5	5	30,626	0,398
	6	1056,9	936,1	35,9	–	1097	1027	981	873	4,5	5	30,626	0,398
900	6	1114,6	987,4	20	–	1157	1087	981	923	3	5	32,311	0,377
	6	1114,6	987,4	20	–	1157	1087	981	923	3	5	32,311	0,377



Needle roller and cage assemblies

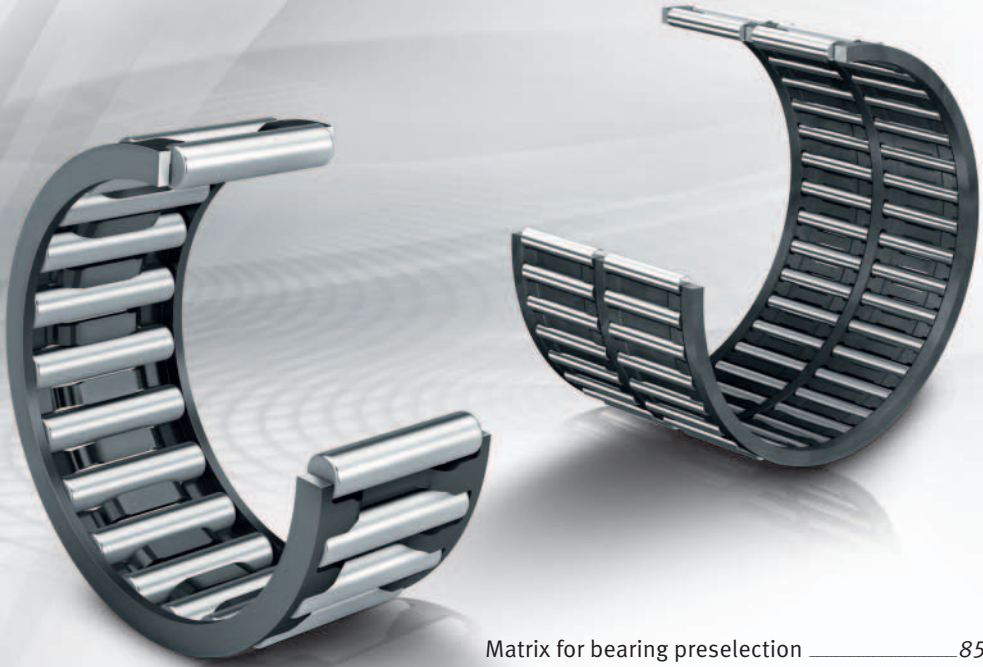

Matrix for bearing preselection 855

1	Needle roller and cage assemblies	856
1.1	Bearing designs	856
1.2	Load carrying capacity	861
1.3	Compensation of angular misalignments	861
1.4	Lubrication	862
1.5	Sealing	862
1.6	Speeds	862



1.7	Noise	862	1.17	Mounting and dismounting	869
1.8	Temperature range	863	1.18	Legal notice regarding data freshness	870
1.9	Cages	863	1.19	Further information	870
1.10	Internal clearance	863	Product table	872	
1.11	Dimensions, tolerances	864	 Needle roller and cage assemblies	872	
1.12	Suffixes	864			
1.13	Structure of bearing designation	864			
1.14	Dimensioning	865			
1.15	Minimum load	865			
1.16	Design of bearing arrangements	866			







Matrix for bearing preselection

The matrix gives an overview of the types and design features of needle roller and cage assemblies.

It can be used to make a preliminary assessment of whether a bearing is fundamentally suitable for the envisaged application.

The additional information provided in the product chapter (see column "detailed information") and in the Technical principles must, however, be observed in selection of the bearing.

Design features and suitability			Needle roller and cage assemblies	
+++ extremely suitable ++ highly suitable + suitable (+) suitable with restrictions - not suitable/not applicable ✓ available			single or double row	detailed information
				856
Load carrying capacity	radial		+++	▶ 861 1.2
	axial, one direction		-	▶ 861 1.2
	axial, both directions		-	▶ 861 1.2
	moments		-	▶ 861 1.2
Compensation of angular misalignments	static		-	▶ 861 1.3
	dynamic		-	▶ 861 1.3
Bearing design	cylindrical bore		-	▶ 856 1.1
	tapered bore		-	▶ 856 1.1
	separable		-	▶ 869 1.17
Lubrication	greased		-	▶ 862 1.4
Sealing	open		✓	▶ 862 1.5
	non-contact		-	▶ 862 1.5
	contact		-	▶ 862 1.5
Operating temperature in °C		from to	-30 +140 ¹⁾	▶ 863 1.8
Suitability for	high speeds		+++	▶ 862 1.6
	high running accuracy		++	▶ 864 1.11 ▶ 114
	low-noise running		+	▶ 862 1.7 ▶ 27
	high rigidity		++	▶ 54
	reduced friction		+	▶ 56
	length compensation within bearing		-	
	non-locating bearing arrangement		++	▶ 139
	locating bearing arrangement		-	▶ 139
X-life bearings		X-life	-	
Enveloping circle diameter F_w in mm		from to	3 265	▶ 872
Product tables		from page	872	

¹⁾ Data valid for needle roller and cage assemblies with sheet steel cage and with cages made from copper-zinc alloy



1 Needle roller and cage assemblies



Radial needle roller and cage assemblies:

- are suitable for applications with a very small radial design envelope, where the raceways on the shaft and in the housing are designed as rolling bearing raceways (direct bearing arrangement)
- can support high radial loads
- allow high speeds
- combine the load carrying capacity advantages of full complement needle roller bearing arrangements with the speed advantages of a cage bearing
- have a high running accuracy
- result in rigid bearing arrangements
- are easy to mount
- permit technically straightforward, economical and cost-effective designs.

For an overview of other product-specific features, see the Matrix for bearing preselection ►855.

 **1**
Radial needle roller and cage assembly – comparison of radial design envelope with drawn cup needle roller bearing with open ends and machined needle roller bearing

- ① Radial needle roller and cage assembly
- ② Drawn cup needle roller bearing with open ends
- ③ Machined needle roller bearing

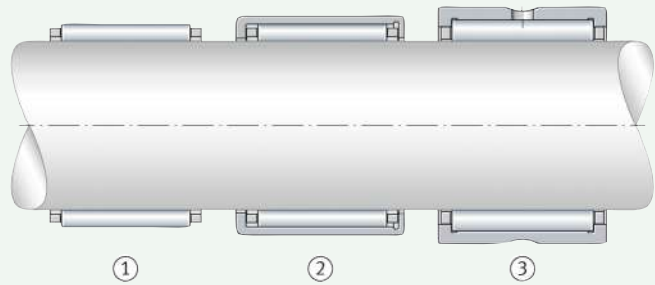

1.1 Bearing designs

 *Design variants*

Radial needle roller and cage assemblies:

- are available in the basic design (K) ►857|② and ►858|③
- are available for centrifugal forces and high acceleration forces (KZK, KBK) ►859|④
- can be customised from profiled strip (K) ►860|⑥.

Needle roller and cage assemblies of basic design

☞ *Bearings with a very small radial section height*

Needle roller and cage assemblies are part of the group of radial needle roller bearings. These ready-to-fit bearing arrangement elements comprise needle cages, which are fitted with needle rollers ▶857|☐2 and ▶858|☒1. They are rolling bearings with a very small radial section height and, apart from full complement needle roller bearing arrangements, are the simplest design of radial needle roller bearing. However, while the design envelope is completely filled with loose needle rollers in full complement needle roller bearing arrangements and, depending on the position, the rolling elements are therefore in contact with each other, these are guided in the cage pockets in needle roller and cage assemblies. The pockets, which are separated from each other by bars and are uniformly distributed around the circumference of the cage, maintain the spacing of the rolling elements relative to each other. The cage and rolling elements thus create a ready-to-fit unit.

☞ *The needle rollers are guided parallel to the axis*

In addition, the bars prevent sliding friction between adjacent rolling elements and guide the rolling elements parallel to the bearing axis in the load-free zone. Guidance parallel to the axis prevents skewing of the needle rollers in the load-free zone. Compared with full complement needle roller bearing arrangements, needle roller and cage assemblies are suitable for higher speeds. As a result, the cage compensates for the disadvantages of a full complement needle roller bearing arrangement.

☞ *For bearing arrangements with a particularly small radial design envelope*

Standard needle roller sorts are used as needle rollers ▶858|☒1. Due to the absence of an inner and outer ring, the radial section height of the bearings is only equivalent to the diameter of the needle rollers. As a result, needle roller and cage assemblies are particularly suitable for applications requiring only a very small radial design envelope. The majority of the bearings are of a single row design ▶857|☐2. This variant has the prefix K.



Needle roller and cage assemblies are only functional once they have been fitted between the housing and shaft. In this case, the raceways must be designed as rolling bearing raceways ▶866|1.16.



Single row needle roller and cage assembly

F_r = radial load

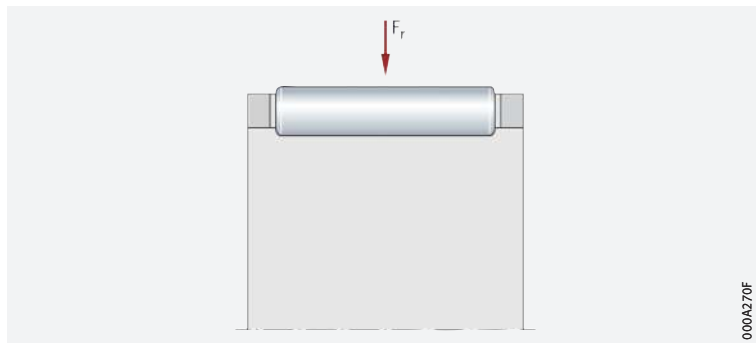

000A270F

☞ *Particularly high radial load carrying capacity*

Double row needle roller and cage assemblies

Double row needle roller and cage assemblies have a higher load carrying capacity than single row designs, but are correspondingly wider ▶858|☐3. These bearings have the prefix K and the suffix ZW and are only available in particular enveloping circle diameters F_w ▶864|1.12 and ▶872|☒.





Double row needle roller and cage assembly

F_r = radial load

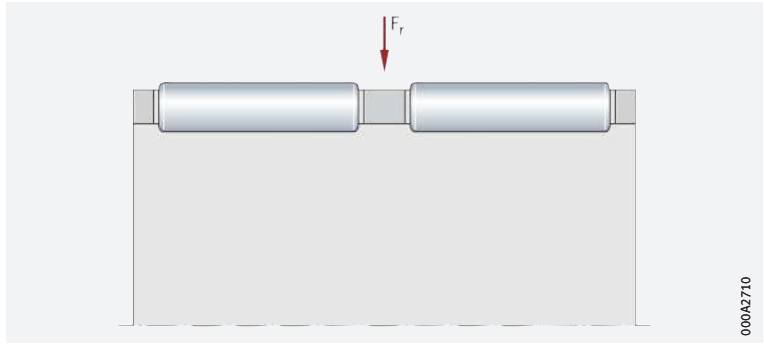

000A2710

Needle rollers

Standard needle roller sorts are used as needle rollers

Needle roller and cage assemblies are supplied with standard needle roller sorts of grade G2 in accordance with the table ▶ 858 | 1. In all cases, needle rollers of only one sort are used in any one needle roller and cage assembly. The sort is printed on the packaging and colour coded ▶ 858 | 1. The sorts are designated by the upper and lower deviations (in μm), the diameter tolerance is a maximum of $2 \mu\text{m}$. In each case, two neighbouring needle roller sorts are matched as sort pairs.



Dimensional and geometrical accuracy of needle rollers of grade G2

Grade	Deviations and tolerances for diameter D_w ¹⁾						Length tolerance	
	Deviation μm	Variation of needle roller diameter within a single sort V_{DwL} μm max.	Sort pair colour code	Sorts μm		Roundness t_{Dw} μm max.		Roughness Ra μm max.
G2	0 - 7	2	red	0 - 2	-1 - 3	1	0,1	h13
			blue	-2 - 4	-3 - 5			
			white (grey)	-4 - 6	-5 - 7			

¹⁾ The tolerance values apply to the centre point of the needle roller.

Needle roller and cage assemblies for centrifugal forces and high acceleration forces (KZK, KBK)

Needle roller and cage assemblies for connecting rod bearing arrangements

Designed for piston pin and crank pin bearing arrangements

Needle roller and cage assemblies for connecting rod bearing arrangements are used in the crank mechanisms of 2 and 4 stroke combustion engines as well as in compressors, for supporting crank pins and piston pins ▶ 859 | 4. These cages support high centrifugal and acceleration forces and are suitable for high speeds.



For piston pin bearing arrangements, only needle roller and cage assemblies with the designation KZK and KBK may be used ▶ TPI 94. As catalogue needle roller and cage assemblies of type K are not designed to accommodate loads generated by centrifugal forces and high acceleration forces, non-compliance may result in failures.



The needle roller and cage assemblies for piston pin and crank pin bearing arrangements are described in detail in Technical Product Information TPI 94. This publication can be requested from Schaeffler.

4 Crank pin and piston pin bearing arrangement

- ① Needle roller and cage assembly for crank pins, externally guided
- ② Needle roller and cage assembly for piston pins, internally guided

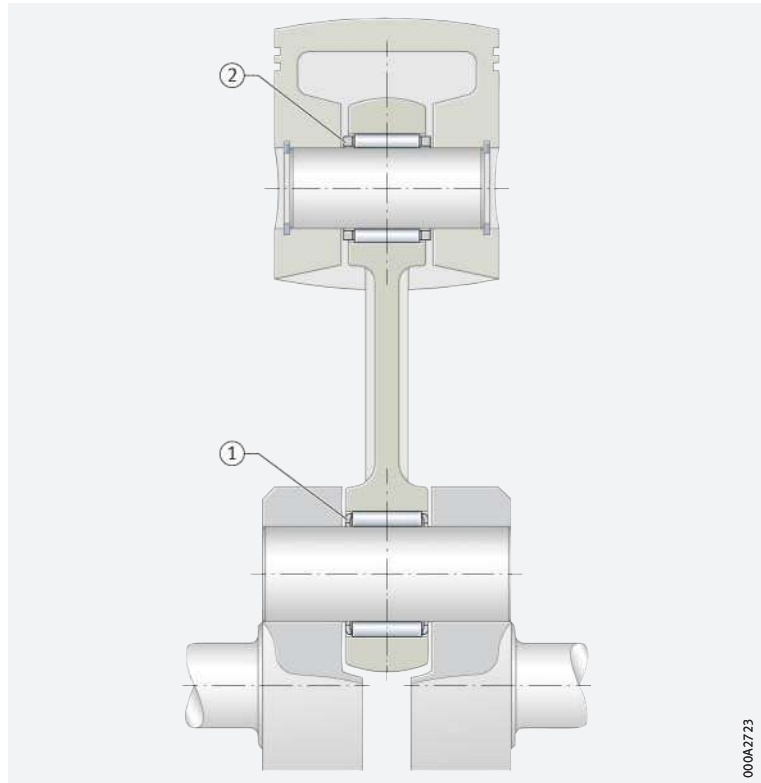

Needle roller and cage assemblies for crank pins (KZK)

Needle roller and cage assemblies for crank pins (series KZK) are externally guided, which means that the connecting rod bore guides the cage radially with little clearance $\blacktriangleright 859 \mid \text{④} 4$. The radial movement of the cage in relation to the connecting rod bore and the rolling elements is as small as possible. The cages are made from quenched and tempered steel, have good wear resistance, high strength and large guidance surfaces which are designed for optimum lubrication.

Needle roller and cage assemblies for piston pins (KBK)

The needle roller and cage assemblies for piston pins (series KBK) are internally guided, which means that the piston pin guides the cage radially with little clearance $\blacktriangleright 859 \mid \text{④} 4$. Due to the small radial internal clearance, tilting of the connecting rod is reduced to a minimum. The bearings support high-frequency oscillating loads and are available for the majority of piston pin diameters in various widths, in accordance with the spacing between the piston centres. The low-wear steel cages are case hardened or quenched and tempered and have high strength.

Needle roller and cage assemblies for planetary gear bearing arrangements (KZK)

Needle roller and cage assemblies for planetary gear bearing arrangements

Needle roller and cage assemblies are also used for applications in planetary gear bearing arrangements, such as automatic gearboxes $\blacktriangleright 860 \mid \text{④} 5$. As very high speeds, as well as centrifugal and acceleration forces, can occur in planetary gear bearing arrangements and the cage is therefore subject to high demands, the responsible Application Engineering and Design functions should select or design a suitable needle roller and cage assembly. In such cases, please consult Schaeffler.



5
Planetary gear
bearing arrangement

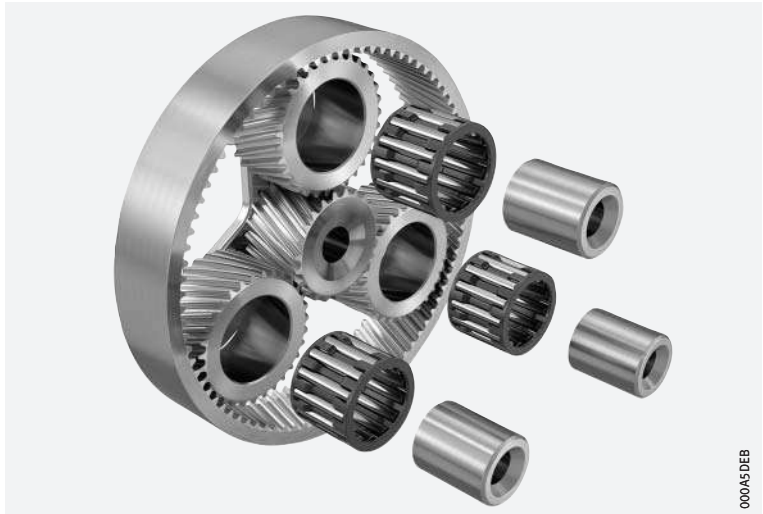

000A5DFB

6
Customised radial
needle roller and
cage assemblies
for specific requirements

Needle roller and cage assemblies customised from profiled strip (K)

These radial needle roller and cage assemblies are produced by bending flat cages BF and fitted with needle rollers after forming ▶860|6. As a result, it is possible to achieve simple designs of clearance-free bearing arrangements with high running accuracy, load carrying capacity and speed suitability, in combination with very small radial and axial section height. Due to their high radial runout accuracy, the bearings are also suitable for precision applications. Since the needle roller and cage assemblies are not tied to defined dimension series but can be precisely produced to a wide range of diameter values in accordance with the specific application (shaft diameter of 105 mm to 1000 mm), they are an economical alternative to catalogue standard bearings. They are normally supplied bent into their final shape but can also be formed by the customer from BF flat cages. After forming, there is an open joint ▶860|6. As a result, radial needle roller and cage assemblies can be easily mounted in recessed raceways. The function of the cages is not impaired by the opening.



BF flat cages and radial needle roller and cage assemblies produced from BF flat cages are described in detail in Technical Product Information TPI 203. This publication can be requested from Schaeffler.

6
Radial needle roller and
cage assembly produced
by bending from a flat cage BF

① Open joint



000A38EA

1.2 Load carrying capacity

☞ *Capable of supporting high radial loads, but not axial loads*

Due to the line contact of the needle rollers, needle roller and cage assemblies are suitable for supporting high radial loads. In contrast to the ball, the needle has a larger contact area perpendicular to its axis. As a result, it can transmit higher forces, has greater rigidity and can support the same loads with smaller rolling element diameters. Due to the needle roller set, double row bearings have a particularly high radial load carrying capacity. They are used when the load carrying capacity of single row bearings is no longer sufficient.



Needle roller and cage assemblies cannot support axial forces ► 865 | 1.14. For axial loads, they can be combined with a bearing which is capable of supporting axial load, such as a deep groove ball bearing or a cylindrical roller bearing with axial load carrying capacity. In such cases, the axial bearing is arranged adjacent to the needle roller and cage assembly ► 861 | 7.



Passenger car gearbox:
bearing arrangement
of main shaft

A – E = bearing positions

- ① Cylindrical roller bearing and cage assembly as pilot bearing (non-locating bearing)
- ② Deep groove ball bearing (locating bearing, capable of supporting axial loads)
- ③ Needle roller and cage assemblies (non-locating bearing, capable of supporting radial loads only)

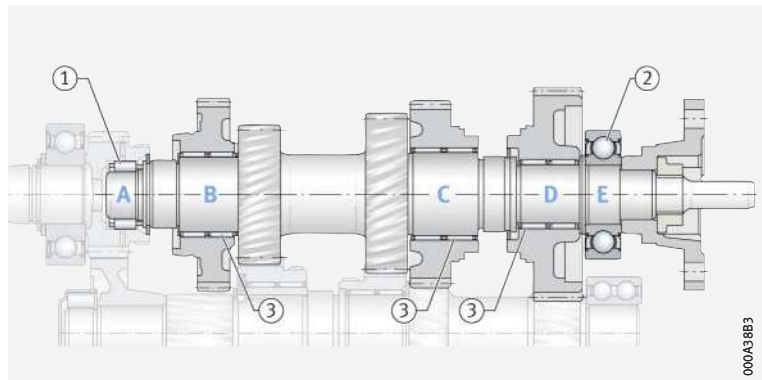

1.3 Compensation of angular misalignments

☞ *The bearings are not suitable for the compensation of shaft misalignments relative to the housing bore*

Needle roller and cage assemblies are not suitable for the compensation of angular misalignments. The extent to which a misalignment of the shaft can be tolerated relative to the housing bore is dependent on factors such as the design of the bearing arrangement, the size of the bearing, the operating clearance and the load. As a result, no guide value can be specified here for a possible misalignment.



In all cases, misalignments cause increased running noise, place increased strain on the cages and have a harmful influence on the operating life of the bearings.



1.4 Lubrication

☞ *Oil or grease lubrication is possible*

Needle roller and cage assemblies are not greased. In order to prevent direct metallic contact between rolling elements, raceways and cages, they must be lubricated. Oil or grease lubrication is suitable. The lubricant reduces the wear and also protects the surfaces against corrosion. The choice of lubricant is essentially dependent on the operating temperatures and speeds, but is also influenced by other factors.

☞ *The use of oil lubrication is preferred*

For most applications involving needle roller and cage assemblies, oil should be used in preference as the lubricant.

☞ *Compatibility with plastic cages*

When using bearings with plastic cages, compatibility between the lubricant and the cage material must be ensured if synthetic oils, lubricating greases with a synthetic oil base or lubricants containing a high proportion of EP additives are used.

☞ *Observe oil change intervals*

Aged oil and additives in the oil can impair the operating life of plastics at high temperatures. As a result, stipulated oil change intervals must be strictly observed.



If there is any uncertainty regarding the suitability of the selected lubricant for the application, please consult Schaeffler or the lubricant manufacturer.

1.5 Sealing

☞ *The bearings are of an open design*

Needle roller and cage assemblies are supplied without seals. As a result, sealing of the bearing position must be carried out in the adjacent construction. This must reliably prevent:

- moisture and contaminants from entering the bearing
- the egress of lubricant from the bearing position.

1.6 Speeds

☞ *Limiting speeds and reference speeds in the product tables*

The product tables give two speeds for the bearings ▶ 872 | :

- the kinematic limiting speed n_G
- the thermal speed rating $n_{\theta T}$.



The limiting speed n_G is the kinematically permissible speed of a bearing. Even under favourable mounting and operating conditions, this value should not be exceeded without prior consultation with Schaeffler ▶ 64. The values in the product tables are valid for oil lubrication.

☞ *Values for grease lubrication*

For grease lubrication, 60% of the value stated in the product tables is permissible in each case.

Reference speeds

☞ *$n_{\theta T}$ is used to calculate n_{θ}*

The thermal speed rating $n_{\theta T}$ is not an application-oriented speed limit, but is a calculated ancillary value for determining the thermally safe operating speed n_{θ} ▶ 64.

1.7 Noise

Schaeffler Noise Index

The Schaeffler Noise Index (SGI) is not yet available for this bearing type ▶ 69. The data for these bearing series will be introduced and updated in stages.

Further information:

- **medias** ▶ <https://medias.schaeffler.com>.

1.8 Temperature range

Limiting values

The operating temperature of the bearings is limited by:

- the dimensional stability of the rolling elements
- the cage
- the lubricant.

Possible operating temperatures of needle roller and cage assemblies

► 863 |  2.

 2
Permissible temperature ranges



Operating temperature	Needle roller and cage assemblies	
	with plastic cage	with sheet steel cage and with cages made from copper-zinc alloy
	-20 °C to +120 °C	-30 °C to +140 °C



In the event of anticipated temperatures which lie outside the stated values, please contact Schaeffler.

1.9 Cages

The standard cages are made from sheet steel

The standard cages are made from sheet steel and, with an enveloping circle diameter $F_w \geq 195$ mm, from a copper-zinc alloy. Bearings with a plastic cage are only available in particular sizes and have the suffix TV ► 864 |  3 and ► 872 | . Other cages are available by agreement. With such cages, however, suitability for high speeds and temperatures as well as the basic load ratings may differ from the values for the bearings with standard cages.



For high continuous temperatures and applications with difficult operating conditions, bearings with sheet steel cages should be used. If there is any uncertainty regarding cage suitability, please consult Schaeffler.

1.10 Internal clearance

Influencing factors on the radial internal clearance

Radial internal clearance

The radial internal clearance can be influenced by the needle roller sort as well as by the shaft and housing tolerances. When standard needle roller sorts are used, a radial internal clearance of C2 to CN is achieved (radial internal clearance for needle and cylindrical roller bearings to DIN 620-4), if the shaft and housing tolerances are observed ► 866 |  4 and normal operating conditions are present. If the actual dimensions have a plus tolerance, a radial internal clearance of 0 can be achieved.

F_w can only be checked in a mounted condition

Checking the enveloping circle diameter

The outer and inner enveloping circle diameters E_w and F_w cannot be measured in an unmounted condition. As a result, the function of the bearings is checked using plug gauges and locating rings in accordance with the methods indicated in DIN 620-1/ISO 1132-2. In order to carry out the check, the needle roller and cage assemblies are placed in a locating ring, which corresponds to the specific nominal dimension E_w of the needle roller and cage assembly. The function of the needle roller and cage assembly is ensured if the plug gauge, which corresponds to the nominal dimension F_w , can be inserted and rotated without jamming.



1.11 Dimensions, tolerances

Dimension standards



The main dimensions of single row needle roller and cage assemblies correspond to DIN 5405-1:2016 and ISO 3030:2011, where standardised.

Tolerances

Needle rollers

The needle rollers correspond to DIN 5402-3:2012 and ISO 3096:1996. The diameters of all needle rollers in a needle roller and cage assembly lie within the tolerance of $2 \mu\text{m}$ \blacktriangleright 863 | 2.

Width B_c

The deviations for cage width B_c are as follows for all needle roller and cage assemblies: $B_c -0,2/-0,8$ \blacktriangleright 872 | 2.

1.12 Suffixes

For a description of the suffixes used in this chapter \blacktriangleright 864 | 3 and **medias** interchange \blacktriangleright <https://www.schaeffler.de/std/1D52>.

3
Suffixes and corresponding descriptions

Suffix	Description of suffix
TV	Cage made from glass fibre reinforced polyamide PA66
ZW	Double row design (only available in certain enveloping circle diameters)

1.13 Structure of bearing designation

The designation of bearings follows a set model. Examples \blacktriangleright 864 | 8 and \blacktriangleright 864 | 9. The composition of designations is subject to DIN 623-1 \blacktriangleright 102 | 10.

8
Single row needle roller and cage assembly: designation structure

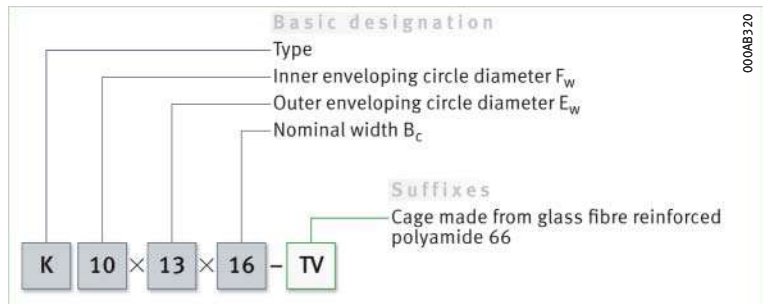

9
Double row needle roller and cage assembly: designation structure

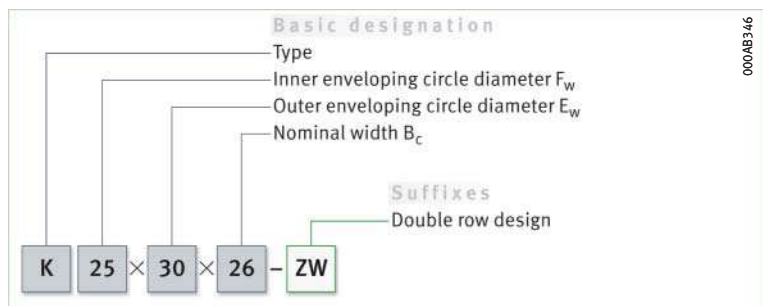

1.14 Dimensioning

$P = F_r$ under purely radial load of constant magnitude and direction



Equivalent dynamic bearing load

The basic rating life equation $L = (C_r/P)^P$ used in the dimensioning of bearings under dynamic load assumes a load of constant magnitude and direction. In radial bearings, this is a purely radial load F_r . If this condition is met, the bearing load F_r is used in the rating life equation for P ($P = F_r$).

Needle roller and cage assemblies can only support radial loads. Thus, for these bearings \blacktriangleright 865 | f1 1.

f1
Equivalent dynamic load

$$P = F_r$$

Legend

P	N	Equivalent dynamic bearing load
F_r	N	Radial load.

Equivalent static bearing load

For needle roller and cage assemblies subjected to static load \blacktriangleright 865 | f1 2.

f2
Equivalent static load

$$P_0 = F_{0r}$$

Legend

P_0	N	Equivalent static bearing load
F_{0r}	N	Largest radial load present (maximum load).

$S_0 = C_0/P_0$

Static load safety factor

In addition to the basic rating life L (L_{10h}), it is also always necessary to check the static load safety factor S_0 \blacktriangleright 865 | f1 3.

f3
Static load safety factor

$$S_0 = \frac{C_0}{P_0}$$

Legend

S_0	–	Static load safety factor
C_0	N	Basic static load rating
P_0	N	Equivalent static bearing load.

1.15 Minimum load

In order to prevent damage due to slippage, a minimum radial load of $P > C_{0r}/60$ is required

In order that no slippage occurs between the contact partners, the needle roller and cage assemblies must be constantly subjected to a sufficiently high load. Based on experience, a minimum radial load of the order of $P > C_{0r}/60$ is thus necessary. In most cases, however, the radial load is already higher than the requisite minimum load due to the weight of the supported parts and the external forces.



If the minimum radial load is lower than indicated above, please consult Schaeffler.



1.16 Design of bearing arrangements



The shaft and housing design and the lateral restriction (axial location) of the bearing position is crucial to the correct function of needle roller and cage assemblies ▶ 866 | 4, ▶ 867 | 10 and ▶ 867 | 11.

Raceways for bearings without bearing rings (direct bearing arrangement)

☞ Produce the raceway as a rolling bearing raceway

If the needle roller and cage assemblies run directly on the shaft and/or in the housing bore (so-called direct bearing arrangement), then the raceway for the rolling elements on the shaft and in the housing must be produced as a rolling bearing raceway (hardened and ground). Design of raceways ▶ 866 | 4. The surface hardness of the raceways must be 670 HV to 840 HV, the hardening depth CHD or SHD must be sufficiently large. The values in the table refer to commonly encountered application examples. If the shaft cannot be produced as a raceway, the needle roller and cage assemblies can be combined with Schaeffler bearing rings. However, the section height of the bearings will then be increased by the thickness of the rings.

4
Tolerance classes and surface design of raceways for needle roller and cage assemblies (direct bearing arrangement)

Shaft diameter		Bore tolerance ¹⁾	Shaft tolerance ¹⁾			Design of raceway		
Nominal dimension mm			Operating clearance			Recommended mean roughness value Ramax (Rzmax)	Roundness tolerance max.	Parallelism tolerance max.
over	incl.		small	normal	large			
-	80	G6	j5	h5	g6	0,2 (1)	IT3	IT3
		H6	h5	g5	f6			
80	120	G6	h5	g5	f6	0,3 (1,6)		
120	-	G6	h5	g5	f6	0,4 (2,5)		
		H6	-	f5	e6			

¹⁾ The envelope requirement © applies.

Raceway width for direct bearing arrangement and axial running surfaces

☞ Mounting dimensions for needle roller and cage assemblies and surface quality of the running surfaces

The raceway width must be at least equal to the nominal width B_c (B_c is produced with a (-) tolerance); values for B_c ▶ 872 | 4 and ▶ 867 | 10. The spacing between the axial running surfaces of the cage must be sufficiently large. The spacing dimension for running surfaces is given as B_c H12 ©, in order to avoid jamming of the needle roller and cage assemblies (H12 in accordance with ISO 286-2). The lateral running surfaces for the needle roller and cage assemblies must be designed as precision machined (Ramax 2 recommended) and wear-resistant ▶ 867 | 10. Interruptions in the running surfaces should be avoided.

☞ Example

For a design envelope of $B_c = 10$ mm, a needle roller and cage assembly with the nominal width $B_c = 10$ mm is suitable, as the maximum cage width is 9,8 (0/-0,6) mm.

10

Raceway width and axial running surfaces for needle roller and cage assemblies

B_c H12 = nominal width

B_c $-0,2/-0,8$ = cage width

Ramax = maximum roughness of running surfaces

- ① Location by means of shaft shoulder, axial washer and snap ring
- ② Axial washer
- ③ Snap ring

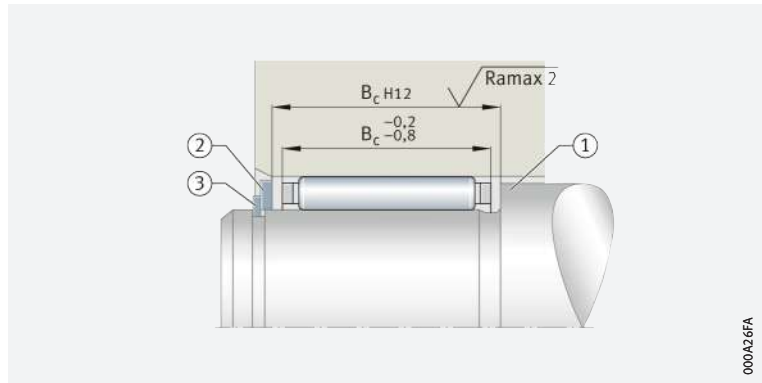

000A26FA

Guidance can be provided by the shaft or on the housing

Axial guidance and location of needle roller and cage assemblies

Needle roller and cage assemblies must be axially guided and located. Guidance can be provided by the shaft or on the housing ▶ 867 | 10 and ▶ 867 | 11. Snap rings or an appropriately designed adjacent construction are suitable for this purpose. If location is by means of snap rings or retaining rings, a washer must be arranged in front of the rings ▶ 867 | 10. The overlap between the ring and washer must be sufficiently large.

11

Axial location by means of housing parts (lateral guidance on housing)

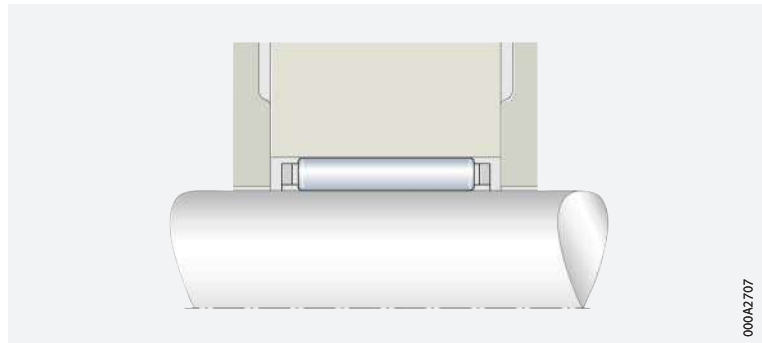

000A2707

Steels for the raceway (direct bearing arrangement)

Through hardening steels



Through hardening steels in accordance with ISO 683-17 (e.g. 100Cr6) are suitable as materials for rolling bearing raceways in direct bearing arrangements. These steels can also be surface layer hardened.

Case hardening steels



Case hardening steels must correspond to DIN EN ISO 683-17 (e.g. 17MnCr5, 18CrNiMo7-6) or EN 10084 (e.g. 16MnCr5).

Steels for inductive surface layer hardening



For flame and induction hardening, steels in accordance with DIN EN ISO 683-17 (e.g. C56E2, 43CrMo4) or DIN 17212 (e.g. Cf53) should be used.



Raceway hardness of less than 670 HV

! If the raceway fulfils the requirements for rolling bearing materials but the raceway hardness is less than 670 HV, the load on the bearing arrangement cannot be as high as the full load carrying capacity of the bearing. In order to determine the dynamic and static load carrying capacity of the bearing arrangement, the basic dynamic load rating C of the bearings must be multiplied by the reduction factor f_H (dynamic hardness factor) and the basic static load rating C_{0r} by the reduction factor f_{H0} (static hardness factor) ➤ 868 | ☐ 12 and ➤ 868 | ☐ 13.

☐ 12
Dynamic hardness factor at reduced hardness of raceways/rolling elements

f_H = dynamic hardness factor
HV, HRC = surface hardness

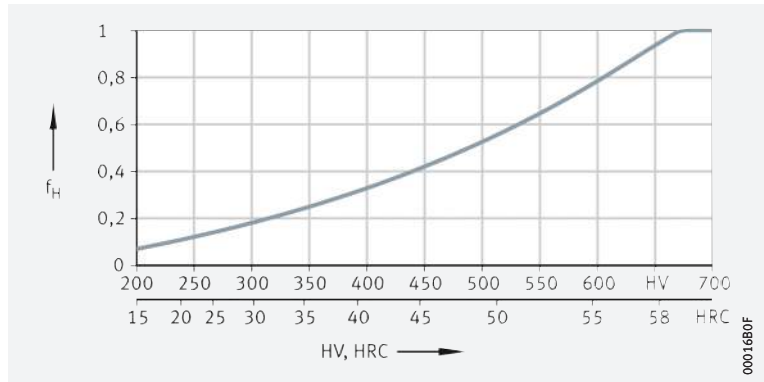

☐ 13
Static hardness factor at reduced hardness of raceways/rolling elements

f_{H0} = static hardness factor
HV, HRC = surface hardness

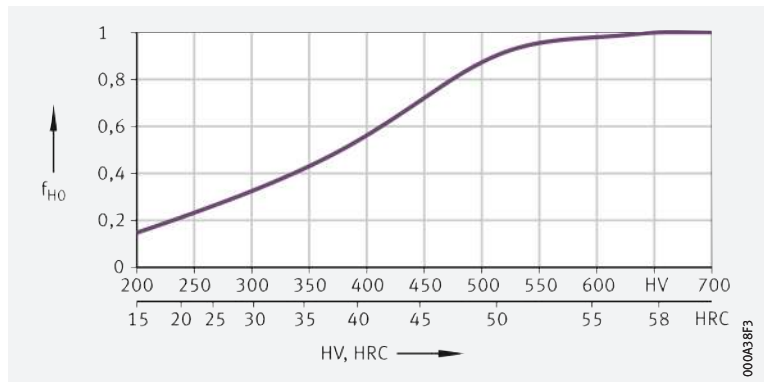

☞ Approximation value for case hardening depth

Determining the case hardening depth

An approximation value for determining the minimum hardness depth is given in ➤ 868 | ☐ 4. The reference value for the load present is the equivalent stress in accordance with the distortion energy hypothesis (DEH) as a function of the rolling element diameter D_w and the magnitude of the load.

☐ 4
Case hardening depth

$$CHD \geq 0,052 \cdot D_w$$

Legend

CHD	mm	Case hardening depth
D_w	mm	Rolling element diameter.

! The local hardness must always be above the local requisite hardness, which can be calculated from the equivalent stress.

Determining the surface hardening depth



In these surface hardening methods, the load and contact geometry must be taken into consideration when determining the requisite hardening depth.

For calculation of the surface hardening depth SHD ► 869 | f 5.

f 5
Surface hardening depth
Legend

$$\text{SHD} \geq 140 \cdot D_w / R_{p0,2}$$

SHD	mm	Surface hardening depth
D_w	mm	Rolling element diameter
$R_{p0,2}$	N/mm ²	Yield point of base material.

Paired arrangement of needle roller and cage assemblies

☞ *The needle rollers must correspond to the same tolerance sort*

If two needle roller and cage assemblies are arranged immediately adjacent to each other, it must be ensured that the bearings are loaded uniformly. In this case, the needle rollers used in these needle roller and cage assemblies must belong to the same diameter sort (tolerance sort). The dimensions of the needle rollers fitted in the bearings must be indicated on the specific bearing packaging.

1.17

Mounting and dismounting

☞ *Ensure that the bearings are not damaged during mounting*

Needle roller and cage assemblies are either slid onto the shaft and then inserted in the housing or are mounted in the housing and the shaft is then inserted. Mounting is carried out without load and using a screwdriver type motion.

☞ *Rolling bearings must be handled with great care*

Schaeffler Mounting Handbook

Rolling bearings are well-proven precision machine elements for the design of economical and reliable bearing arrangements, which offer high operational security. In order that these products can function correctly and achieve the envisaged operating life without detrimental effect, they must be handled with care.



The Schaeffler Mounting Handbook MH 1 gives comprehensive information about the correct storage, mounting, dismounting and maintenance of rotary rolling bearings ► <https://www.schaeffler.de/std/1D53>. It also provides information which should be observed by the designer, in relation to the mounting, dismounting and maintenance of bearings, in the original design of the bearing position. This book is available from Schaeffler on request.



1.18 Legal notice regarding data freshness

The further development of products may also result in technical changes to catalogue products

Of central interest to Schaeffler is the further development and optimisation of its products and the satisfaction of its customers. In order that you, as the customer, can keep yourself optimally informed about the progress that is being made here and with regard to the current technical status of the products, we publish any product changes which differ from the printed version in our electronic product catalogue.



We therefore reserve the right to make changes to the data and illustrations in this catalogue. This catalogue reflects the status at the time of printing. More recent publications released by us (as printed or digital media) will automatically precede this catalogue if they involve the same subject. Therefore, please always use our electronic product catalogue to check whether more up-to-date information or modification notices exist for your desired product.

Link to electronic product catalogue



The following link will take you to the Schaeffler electronic product catalogue: ► <https://medias.schaeffler.com>.

1.19 Further information

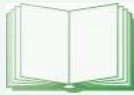

In addition to the data in this chapter, the following chapters in Technical principles must also be observed in the design of bearing arrangements:

- Determining the bearing size ► 34
- Rigidity ► 54
- Friction and increases in temperature ► 56
- Speeds ► 64
- Bearing data ► 97
- Lubrication ► 70
- Sealing ► 182
- Design of bearing arrangements ► 139
- Mounting and dismounting ► 191.





Needle roller and cage assemblies

Single row

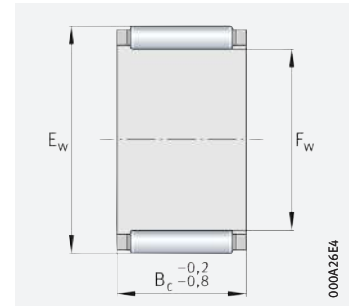

Single row

$F_w = 3 - 19 \text{ mm}$

Main dimensions			Basic load ratings		Fatigue limit load	Limiting speed	Speed rating	Mass	Designation
F_w	E_w	B_c	dyn. C_r N	stat. C_{0r} N	C_{ur} N	n_G min^{-1}	$n_{\partial r}$ min^{-1}	m $\approx \text{g}$	▶ 864 1.12 ▶ 864 1.13
3	5	7	1 540	1 290	152	50 000	78 000	0,3	K3×5×7-TV
	5	9	1 710	1 480	188	50 000	80 000	0,4	K3×5×9-TV
	6	7	1 430	970	109	47 000	75 000	0,4	K3×6×7-TV
4	7	10	2 330	1 840	236	42 500	59 000	0,7	K4×7×10-TV
	7	7	1 740	1 270	145	42 500	59 000	0,5	K4×7×7-TV
5	8	10	3 000	2 650	350	39 000	47 000	0,9	K5×8×10-TV
	8	8	2 350	1 920	237	39 000	48 000	0,7	K5×8×8-TV
6	10	13	3 800	3 100	395	35 500	40 000	1,9	K6×10×13-TV
	9	10	3 350	3 150	420	36 500	40 000	1,1	K6×9×10-TV
	9	8	2 600	2 280	285	36 500	41 000	0,8	K6×9×8-TV
7	10	10	3 650	3 600	485	34 500	35 000	1	K7×10×10-TV
	10	8	2 850	2 650	330	34 500	36 000	0,9	K7×10×8-TV
	9	7	1 680	1 700	203	35 500	40 500	0,6	K7×9×7-TV
8	11	10	3 950	4 100	560	32 500	31 000	1,2	K8×11×10-TV
	11	13	5 100	5 800	790	32 500	30 500	1,7	K8×11×13-TV
	11	8	3 100	3 000	375	32 500	32 000	1	K8×11×8-TV
	12	10	5 000	4 700	560	31 500	29 000	2	K8×12×10-TV
9	12	10	4 500	5 000	680	31 000	27 500	1,5	K9×12×10-TV
	12	13	5 900	7 100	970	31 000	27 000	2,1	K9×12×13-TV
10	13	10	4 750	5 500	750	29 500	24 900	1,6	K10×13×10-TV
	13	13	6 200	7 800	1 060	29 500	24 400	2,3	K10×13×13-TV
	13	16	7 100	9 300	1 310	29 500	24 600	2,9	K10×13×16-TV
	14	10	5 800	6 000	720	29 000	23 500	2,5	K10×14×10-TV
	14	13	7 500	8 400	1 020	29 000	23 000	4,6	K10×14×13-TV
	16	12	8 100	7 200	1 000	27 500	21 800	5,5	K10×16×12-TV
12	15	10	4 900	6 100	830	27 000	21 500	2,9	K12×15×10-TV
	15	13	6 400	8 500	1 170	27 000	21 100	2,3	K12×15×13-TV
	16	13	8 000	9 400	1 150	26 500	19 900	3,6	K12×16×13-TV
	17	13	9 600	10 400	1 330	26 500	18 800	4,9	K12×17×13-TV
	18	12	10 000	9 900	1 400	26 000	18 100	6	K12×18×12-TV

medias ▶ <https://www.schaeffler.de/std/1DF2>



Main dimensions			Basic load ratings		Fatigue limit load	Limiting speed	Speed rating	Mass	Designation
F_w	E_w	B_c	dyn. C_r	stat. C_{0r}	C_{ur}	n_G	$n_{\theta r}$	m	► 864 1.12 ► 864 1.13
			N	N	N	min^{-1}	min^{-1}	≈ g	
14	18	10	7 100	8 500	1 060	25 000	17 300	4	K14×18×10
	18	13	8 200	10 100	1 320	25 000	17 700	6,5	K14×18×13
	18	15	9 500	12 300	1 540	25 000	17 400	5	K14×18×15-TV
	18	17	10 800	14 400	1 890	25 000	17 300	8	K14×18×17
	20	12	10 300	10 600	1 490	24 300	16 200	8,5	K14×20×12
15	18	17	8 000	12 100	1 730	24 600	17 700	4,6	K15×18×17-TV
	19	10	7 500	9 200	1 140	24 300	16 200	5	K15×19×10
	19	13	8 500	10 900	1 420	24 300	16 600	7	K15×19×13
	19	17	11 300	15 600	2 040	24 300	16 200	9,5	K15×19×17
	20	13	9 900	11 500	1 430	23 900	15 900	7	K15×20×13
	21	15	14 300	16 400	2 210	23 600	14 700	11	K15×21×15
	21	21	19 400	24 300	3 300	23 600	14 400	17	K15×21×21
16	20	10	7 800	9 900	1 230	23 600	15 200	5,5	K16×20×10
	20	13	8 900	11 800	1 530	23 600	15 600	7,5	K16×20×13
	20	17	11 700	16 800	2 190	23 600	15 200	10	K16×20×17
	22	12	11 500	12 500	1 780	22 900	14 300	10	K16×22×12
	22	16	14 800	17 500	2 390	22 900	14 100	12	K16×22×16
	22	20	18 300	22 800	3 050	22 900	14 000	17	K16×22×20
	24	20	21 400	23 500	2 950	22 400	13 200	22	K16×24×20
17	21	10	8 100	10 600	1 310	22 900	14 400	5,5	K17×21×10
	21	13	10 400	14 600	1 810	22 900	14 100	6,5	K17×21×13
	21	17	12 200	17 900	2 350	22 900	14 400	9,5	K17×21×17
18	22	10	8 400	11 300	1 400	22 400	13 600	6	K18×22×10
	22	13	9 200	12 700	1 650	22 400	14 200	8	K18×22×13
	22	17	12 100	18 000	2 360	22 400	13 900	11	K18×22×17
	24	12	12 800	14 900	2 120	21 800	12 700	12	K18×24×12
	24	13	13 100	15 300	1 990	21 800	12 900	13	K18×24×13
	24	20	20 200	27 000	3 550	21 800	12 400	18	K18×24×20
	25	22	23 100	29 000	3 750	21 600	12 200	23	K18×25×22
19	23	13	9 500	13 500	1 750	21 800	13 500	8	K19×23×13
	23	17	12 500	19 200	2 500	21 800	13 200	11	K19×23×17

medias ► <https://www.schaeffler.de/std/1DF3>





Needle roller and cage assemblies

Single row
Double row

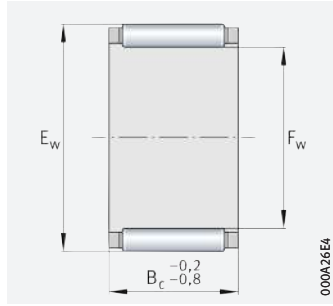

Single row

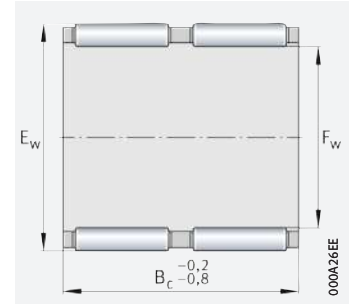

Double row (K...ZW)

F_w = 20 – 30 mm

Main dimensions			Basic load ratings		Fatigue limit load	Limiting speed	Speed rating	Mass	Designation
F _w	E _w	B _c	dyn. C _r N	stat. C _{0r} N	C _{ur} N	n _G min ⁻¹	n _{dr} min ⁻¹	m ≈ g	➤ 864 1.12 ➤ 864 1.13
20	24	10	8 900	12 600	1 570	21 300	12 400	6,5	K20×24×10
	24	13	9 800	14 300	1 860	21 300	12 800	9	K20×24×13
	24	17	12 900	20 400	2 650	21 300	12 500	12	K20×24×17
	26	12	13 400	16 200	2 310	20 900	11 700	11	K20×26×12
	26	13	14 400	17 900	2 330	20 900	11 600	12	K20×26×13
	26	17	19 200	26 000	3 300	20 900	11 200	16	K20×26×17
	26	20	21 100	29 000	3 900	20 900	11 400	19	K20×26×20
	28	16	19 800	22 400	3 000	20 400	11 100	20	K20×28×16
	28	20	23 900	28 500	3 600	20 400	11 100	27	K20×28×20
	28	25	30 500	39 000	5 300	20 400	10 800	32	K20×28×25
	30	30	35 500	41 500	5 500	19 600	10 800	49	K20×30×30
21	25	13	10 100	15 100	1 970	20 900	12 300	9	K21×25×13
22	26	10	9 100	13 400	1 670	20 400	11 500	7,5	K22×26×10
	26	13	10 400	15 900	2 080	20 400	11 800	9,5	K22×26×13
	26	17	13 700	22 700	3 000	20 400	11 500	12	K22×26×17
	28	17	19 400	27 000	3 450	19 600	10 500	18	K22×28×17
	29	16	20 000	25 500	3 350	19 200	10 300	16	K22×29×16
	30	15	20 100	23 400	3 050	18 800	10 200	18	K22×30×15-TV
	32	24	34 000	40 000	4 900	18 100	9 700	43	K22×32×24
23	35	16	24 500	23 900	2 950	16 900	9 500	29	K23×35×16-TV
24	28	10	9 600	14 800	1 840	18 800	10 600	8,5	K24×28×10
	28	13	11 000	17 600	2 290	18 800	10 800	10	K24×28×13
	28	17	14 500	25 000	3 300	18 800	10 600	13	K24×28×17
	30	17	19 500	27 500	3 500	18 100	10 000	19	K24×30×17
	30	31	27 500	43 500	5 800	18 100	10 400	32	K24×30×31-ZW

medias ➤ <https://www.schaeffler.de/std/1DF4>



Main dimensions			Basic load ratings		Fatigue limit load C_{ur} N	Limiting speed n_G min^{-1}	Speed rating $n_{\theta r}$ min^{-1}	Mass m ≈ g	Designation ► 864 1.12 ► 864 1.13
F_w	E_w	B_c	dyn. C_r N	stat. C_{0r} N					
25	29	10	9 900	15 400	1 930	18 100	10 200	8,5	K25×29×10
	29	13	11 300	18 400	2 400	18 100	10 400	11	K25×29×13
	29	17	14 900	26 000	3 450	18 100	10 200	14	K25×29×17
	30	13	14 600	21 800	2 800	17 800	9 800	12	K25×30×13
	30	17	18 700	30 000	3 850	17 800	9 600	16	K25×30×17
	30	20	21 700	36 500	4 850	17 800	9 500	18	K25×30×20
	30	26	21 400	35 500	4 500	17 800	10 400	19	K25×30×26-ZW
	31	17	19 600	28 500	3 600	17 500	9 600	19	K25×31×17
	31	21	24 700	38 000	5 100	17 500	9 400	20	K25×31×21
	32	16	20 800	27 500	3 650	17 200	9 400	21	K25×32×16
	33	20	28 500	38 000	4 850	16 900	9 000	33	K25×33×20
	33	24	34 000	47 000	6 300	16 900	8 900	39	K25×33×24
	35	30	47 000	62 000	8 300	16 300	8 500	65	K25×35×30
26	30	13	11 600	19 200	2 500	17 500	10 100	11	K26×30×13
	30	17	15 200	27 500	3 600	17 500	9 800	15	K26×30×17
	30	22	15 700	28 500	3 550	17 500	10 400	12	K26×30×22-ZW
28	33	13	15 300	24 200	3 100	16 100	8 900	13	K28×33×13
	33	17	19 700	33 500	4 250	16 100	8 700	17	K28×33×17
	34	17	21 800	33 500	4 300	15 800	8 600	24	K28×34×17
	35	16	21 500	29 500	3 950	15 600	8 700	24	K28×35×16
	35	18	24 000	34 000	4 700	15 600	8 600	27	K28×35×18
	40	25	45 500	55 000	6 600	14 400	7 700	70	K28×40×25
30	34	13	12 300	21 700	2 850	15 300	8 900	14	K30×34×13
	35	13	15 600	25 500	3 250	15 100	8 400	14	K30×35×13
	35	17	19 600	34 000	4 300	15 100	8 300	19	K30×35×17
	35	27	30 500	59 000	8 500	15 100	8 100	30	K30×35×27
	37	16	23 100	33 500	4 450	14 600	8 000	27	K30×37×16
	37	18	26 000	38 500	5 300	14 600	8 000	30	K30×37×18
	40	18	32 000	40 000	5 000	14 000	7 600	48	K30×40×18
	40	30	49 000	69 000	9 200	14 000	7 500	73	K30×40×30

medias ► <https://www.schaeffler.de/std/1DF5>





Needle roller and cage assemblies

Single row
Double row

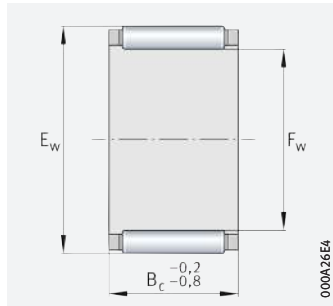

Single row

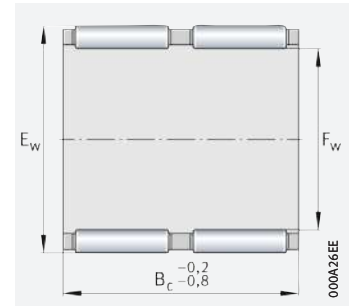

Double row (K...ZW)

F_w = 32 – 47 mm

Main dimensions			Basic load ratings		Fatigue limit load	Limiting speed	Speed rating	Mass	Designation
F _w	E _w	B _c	dyn. C _r N	stat. C _{0r} N	C _{ur} N	n _G min ⁻¹	n _{dr} min ⁻¹	m ≈ g	▶ 864 1.12 ▶ 864 1.13
32	37	13	15 500	25 500	3 300	14 200	8 100	18	K32×37×13
	37	17	19 900	35 500	4 500	14 200	7 900	19	K32×37×17
	37	27	30 000	60 000	8 500	14 200	7 800	30	K32×37×27
	38	20	26 500	45 000	6 000	14 000	7 700	30	K32×38×20
	39	16	23 800	35 500	4 700	13 800	7 600	37	K32×39×16
	39	18	26 500	41 000	5 600	13 800	7 500	31	K32×39×18
	40	25	37 500	58 000	7 900	13 600	7 400	49	K32×40×25
	40	42	50 000	84 000	10 500	13 600	7 800	77	K32×40×42-ZW-TV
46	32	66 000	84 000	11 100	12 600	6 700	119	K32×46×32	
35	40	13	16 200	28 000	3 600	13 100	7 500	19	K35×40×13
	40	17	20 800	38 500	4 900	13 100	7 400	21	K35×40×17
	40	25	29 500	60 000	8 400	13 100	7 200	31	K35×40×25
	40	27	25 000	48 500	6 700	13 100	7 900	39	K35×40×27-TV
	42	16	24 400	37 500	5 000	12 700	7 100	34	K35×42×16
	42	18	27 500	43 000	6 000	12 700	7 100	34	K35×42×18
	42	20	30 000	49 000	6 200	12 700	7 000	37	K35×42×20
	42	30	39 000	68 000	9 400	12 700	7 200	67	K35×42×30
	45	20	37 000	50 000	6 500	12 300	6 800	56	K35×45×20
	45	30	53 000	79 000	10 500	12 300	6 700	80	K35×45×30
37	42	17	22 400	43 000	5 500	12 400	6 900	22	K37×42×17
38	43	17	20 500	38 500	4 850	12 100	7 000	29	K38×43×17
	43	27	31 500	68 000	9 600	12 100	6 800	43	K38×43×27
	46	20	35 500	57 000	7 200	11 700	6 300	47	K38×46×20
	46	32	55 000	99 000	14 200	11 700	6 200	76	K38×46×32
39	44	26	27 500	56 000	7 100	11 800	7 000	45	K39×44×26-ZW

medias ▶ <https://www.schaeffler.de/std/1DF6>



Main dimensions			Basic load ratings		Fatigue limit load C_{ur} N	Limiting speed n_G min^{-1}	Speed rating $n_{\partial r}$ min^{-1}	Mass m $\approx \text{g}$	Designation ►864 1.12 ►864 1.13
F_w	E_w	B_c	dyn. C_r N	stat. C_{Or} N					
40	45	13	17 600	32 500	4 200	11 500	6 600	22	K40×45×13
	45	17	21 400	41 500	5 200	11 500	6 700	31	K40×45×17
	45	27	33 000	73 000	10 300	11 500	6 500	46	K40×45×27
	47	18	29 500	50 000	6 900	11 300	6 300	39	K40×47×18
	47	20	32 500	57 000	7 200	11 300	6 200	42	K40×47×20
	48	20	36 000	59 000	7 500	11 100	6 100	49	K40×48×20
42	47	13	17 800	33 500	4 350	11 000	6 400	18	K42×47×13
	47	17	21 700	43 000	5 400	11 000	6 400	32	K42×47×17
	47	30	33 500	76 000	10 000	11 000	6 400	54	K42×47×30-ZW
	50	20	35 000	57 000	7 300	10 700	6 000	53	K42×50×20
43	48	17	21 600	43 000	5 400	10 800	6 300	30	K43×48×17
	48	27	33 500	75 000	10 700	10 800	6 200	50	K43×48×27
45	50	17	22 500	46 000	5 800	10 300	6 100	34	K45×50×17
	50	27	34 500	80 000	11 400	10 300	5 900	51	K45×50×27
	52	18	31 500	57 000	7 900	10 100	5 700	42	K45×52×18
	53	20	39 000	67 000	8 700	10 000	5 500	55	K45×53×20
	53	21	38 500	67 000	8 600	10 000	5 600	60	K45×53×21
	53	28	52 000	98 000	13 700	10 000	5 400	81	K45×53×28
	59	18	44 500	54 000	6 900	9 400	5 400	72	K45×59×18-TV
	59	32	73 000	103 000	13 800	9 400	5 300	148	K45×59×32
47	52	17	23 300	49 000	6 100	9 900	5 800	35	K47×52×17
	52	27	35 000	83 000	11 800	9 900	5 700	51	K47×52×27

medias ► <https://www.schaeffler.de/std/1DF7>





Needle roller and cage assemblies

Single row
Double row

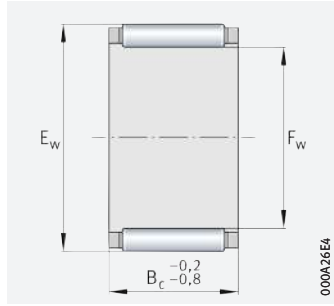

Single row

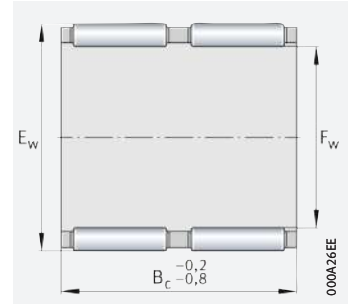

Double row (K...ZW)

F_w = 50 – 95 mm

Main dimensions			Basic load ratings		Fatigue limit load C _{ur} N	Limiting speed n _G min ⁻¹	Speed rating n _{gr} min ⁻¹	Mass m ≈ g	Designation ▶ 864 1.12 ▶ 864 1.13
F _w	E _w	B _c	dyn. C _r N	stat. C _{0r} N					
50	55	13,5	18 200	36 500	4 600	9 300	5 700	30	K50×55×13,5
	55	17	26 000	57 000	7 300	9 300	5 300	35	K50×55×17
	55	20	26 500	60 000	7 800	9 300	5 500	43	K50×55×20
	55	30	39 000	97 000	13 900	9 300	5 400	65	K50×55×30
	57	18	33 500	63 000	8 800	9 200	5 200	47	K50×57×18
	58	20	35 500	62 000	8 800	9 100	5 400	75	K50×58×20
	58	25	44 000	81 000	10 800	9 100	5 300	90	K50×58×25
52	57	12	18 000	36 500	4 600	9 000	5 400	24	K52×57×12
55	60	20	28 500	66 000	8 600	8 500	5 100	40	K55×60×20
	60	27	38 000	97 000	13 600	8 500	4 950	60	K55×60×27
	60	30	41 000	108 000	15 400	8 500	4 950	71	K55×60×30
	62	18	35 500	70 000	9 800	8 400	4 750	52	K55×62×18
	63	20	40 000	74 000	9 500	8 300	4 800	67	K55×63×20
	63	25	50 000	100 000	13 700	8 300	4 700	80	K55×63×25
	63	32	62 000	130 000	18 600	8 300	4 650	102	K55×63×32
58	65	18	35 000	70 000	9 800	8 000	4 650	52	K58×65×18
	65	36	49 000	107 000	14 600	8 000	5 100	127	K58×65×36-ZW
60	65	20	29 500	72 000	9 300	7 800	4 750	52	K60×65×20
	65	30	42 500	116 000	16 600	7 800	4 650	77	K60×65×30
	66	33	46 000	112 000	15 100	7 800	4 800	104	K60×66×33-ZW
	66	40	58 000	151 000	19 900	7 800	4 650	116	K60×66×40-ZW
	68	20	43 500	85 000	11 000	7 700	4 400	71	K60×68×20
	68	23	49 500	101 000	13 500	7 700	4 350	94	K60×68×23
	68	25	53 000	111 000	15 200	7 700	4 350	89	K60×68×25
	68	30	44 500	88 000	11 300	7 700	4 950	129	K60×68×30-ZW
	75	42	118 000	199 000	27 000	7 300	4 050	240	K60×75×42
	62	70	40	66 000	146 000	20 500	7 400	4 550	174
64	70	16	28 000	60 000	8 100	7 300	4 500	53	K64×70×16

medias ▶ <https://www.schaeffler.de/std/1DF8>



Main dimensions			Basic load ratings		Fatigue limit load	Limiting speed	Speed rating	Mass	Designation
F_w	E_w	B_c	dyn. C_r N	stat. C_{0r} N	C_{ur} N	n_G min^{-1}	$n_{\partial r}$ min^{-1}	m $\approx \text{g}$	▶ 864 1.12 ▶ 864 1.13
65	70	20	30 500	77 000	10 000	7 300	4 450	56	K65×70×20
	70	30	44 000	124 000	17 800	7 300	4 350	83	K65×70×30
	73	23	46 000	94 000	12 200	7 100	4 300	108	K65×73×23
	73	30	57 000	123 000	17 100	7 100	4 300	141	K65×73×30
68	74	20	35 500	84 000	11 000	6 900	4 200	71	K68×74×20
	74	30	46 500	118 000	16 900	6 900	4 300	100	K68×74×30
	74	35	48 500	125 000	17 200	6 900	4 450	120	K68×74×35-ZW
70	76	20	36 000	86 000	11 300	6 700	4 100	71	K70×76×20
	76	30	52 000	139 000	20 100	6 700	4 000	110	K70×76×30
	78	30	60 000	135 000	18 800	6 600	4 000	148	K70×78×30
72	80	20	41 500	85 000	11 900	6 400	4 000	98	K72×80×20
73	79	20	37 000	90 000	11 800	6 400	4 000	75	K73×79×20
75	81	20	37 500	94 000	12 300	6 300	3 850	79	K75×81×20
	81	30	52 000	143 000	20 400	6 300	3 850	114	K75×81×30
	83	23	50 000	109 000	14 200	6 200	3 800	124	K75×83×23
	83	30	62 000	143 000	20 000	6 200	3 800	147	K75×83×30
	83	35	63 000	147 000	19 900	6 200	3 950	182	K75×83×35-ZW
	83	40	73 000	177 000	25 000	6 200	3 900	211	K75×83×40-ZW
80	86	20	38 500	98 000	12 900	5 900	3 700	60	K80×86×20
	88	30	71 000	176 000	25 000	5 800	3 400	138	K80×88×30
	88	40	76 000	192 000	27 000	5 800	3 700	227	K80×88×40-ZW
	88	46	88 000	231 000	30 000	5 800	3 650	260	K80×88×46-ZW
85	92	20	44 500	108 000	15 100	5 500	3 450	102	K85×92×20
90	97	20	45 000	113 000	15 800	5 200	3 300	109	K90×97×20
	98	27	61 000	150 000	20 300	5 200	3 300	150	K90×98×27
	98	30	68 000	172 000	24 000	5 200	3 300	172	K90×98×30
95	103	30	69 000	180 000	25 000	4 950	3 150	165	K95×103×30
	103	40	83 000	228 000	32 500	4 950	3 200	266	K95×103×40-ZW

medias ▶ <https://www.schaeffler.de/std/1DF9>





Needle roller and cage assemblies

Single row

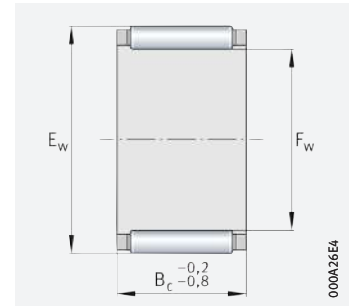

Single row

$F_w = 100 - 265 \text{ mm}$

Main dimensions			Basic load ratings		Fatigue limit load C_{ur} N	Limiting speed n_G min^{-1}	Speed rating $n_{\partial r}$ min^{-1}	Mass m $\approx \text{g}$	Designation ► 864 1.12 ► 864 1.13
F_w	E_w	B_c	dyn. C_r N	stat. C_{0r} N					
100	107	21	48 000	127 000	17 600	4 750	3 100	120	K100×107×21
	108	27	57 000	143 000	18 900	4 700	3 200	185	K100×108×27
	108	30	71 000	188 000	26 000	4 700	3 050	180	K100×108×30
105	112	21	47 500	127 000	17 400	4 500	3 000	129	K105×112×21
110	117	24	56 000	158 000	19 800	4 300	2 850	172	K110×117×24
	118	30	78 000	219 000	29 500	4 300	2 750	217	K110×118×30
115	123	27	63 000	170 000	21 600	4 100	2 850	200	K115×123×27
120	127	24	59 000	174 000	21 400	3 950	2 650	165	K120×127×24
125	133	35	86 000	260 000	34 500	3 800	2 600	275	K125×133×35
130	137	24	61 000	186 000	22 300	3 650	2 500	170	K130×137×24
135	143	35	91 000	290 000	37 500	3 550	2 390	300	K135×143×35
145	153	26	74 000	225 000	27 000	3 300	2 280	262	K145×153×26
150	160	46	147 000	470 000	60 000	3 150	2 100	570	K150×160×46
155	163	26	75 000	236 000	28 000	3 100	2 180	265	K155×163×26
160	170	46	152 000	510 000	63 000	2 950	1 970	550	K160×170×46
165	173	26	81 000	265 000	30 500	2 900	2 030	320	K165×173×26
175	183	32	99 000	350 000	41 500	2 750	1 930	400	K175×183×32
185	195	37	128 000	425 000	48 500	2 600	1 840	607	K185×195×37
195	205	37	133 000	450 000	51 000	2 450	1 760	620	K195×205×37
210	220	42	154 000	560 000	63 000	2 280	1 590	740	K210×220×42
220	230	42	158 000	590 000	66 000	2 180	1 510	790	K220×230×42
240	250	42	164 000	630 000	69 000	2 000	1 390	850	K240×250×42
265	280	50	255 000	860 000	91 000	1 800	1 160	1 810	K265×280×50

medias ► <https://www.schaeffler.de/std/1DFA>



Drawn cup needle roller bearings



Matrix for bearing preselection 885

1 Drawn cup needle roller bearings 886

- 1.1 Bearing design 886
- 1.2 Load carrying capacity 889
- 1.3 Compensation of angular misalignments 889
- 1.4 Lubrication 889
- 1.5 Sealing 890
- 1.6 Speeds 891



1.7	Noise	891	1.18	Legal notice regarding data freshness	899
1.8	Temperature range	891	1.19	Further information	899
1.9	Cages	892	Product tables	900	
1.10	Internal clearance	892		<i>Drawn cup needle roller bearings with open ends, drawn cup needle roller bearings with closed end, unsealed</i>	900
1.11	Dimensions, tolerances	893		<i>Drawn cup needle roller bearings with open ends, drawn cup needle roller bearings with closed end, sealed</i>	906
1.12	Suffixes	893		<i>Drawn cup needle roller bearings with open ends, full complement, unsealed</i>	908
1.13	Structure of bearing designation	894			
1.14	Dimensioning	894			
1.15	Minimum load	895			
1.16	Design of bearing arrangements	895			
1.17	Mounting and dismounting	898			







Matrix for bearing preselection

The matrix gives an overview of the types and design features of drawn cup needle roller bearings.

It can be used to make a preliminary assessment of whether a bearing is fundamentally suitable for the envisaged application.

The additional information provided in the product chapter (see column "detailed information") and in the Technical principles must, however, be observed in addition to this overview in selection of the bearing.

Design features and suitability			Drawn cup needle roller bearings			
			open	sealed	full complement, open	detailed information
+++ extremely suitable ++ highly suitable + suitable (+) suitable with restrictions – not suitable/not applicable available ✓ available						886
Load carrying capacity	radial		+++	+++	+++	889 1.2
	axial, one direction		–	–	–	889 1.2
	axial, both directions		–	–	–	889 1.2
	moments		–	–	–	
Compensation of angular misalignments	static		–	–	–	889 1.3
	dynamic		–	–	–	889 1.3
Bearing design	cylindrical bore		✓	✓	✓	886 1.1
	tapered bore		–	–	–	
	separable		–	–	–	898 1.17
Lubrication	greased		–	✓	– ¹⁾	889 1.4
Sealing	open		✓	–	✓	890 1.5
	non-contact		–	–	–	890 1.5
	contact		–	✓	–	890 1.5
Operating temperature in °C	from to		–30 +140 ²⁾	–20 +100	–30 +140	891 1.8
Suitability for	high speeds		+++	+++	+	891 1.6
	high running accuracy		++	++	++	893 1.11 114
	low-noise running		+	+	+	891 1.7 27
	high rigidity		++	++	++	54
	reduced friction		+	+	+	56
	length compensation within bearing		–	–	–	
	non-locating bearing arrangement		++	++	++	139
	locating bearing arrangement		–	–	–	139
X-life bearings			X-life	–	–	
Enveloping circle diameter F_w in mm	from to		2 60	8 50	8 50	900
Product tables			from page	900	906	908

¹⁾ Delivery with special grease for mounting only, bearings must be relubricated

²⁾ Valid for open, ungreased bearings with sheet steel cage. With polyamide cage –20 °C to +120 °C



1 Drawn cup needle roller bearings



The bearings:

- are particularly suitable for applications with a very small radial section height on account of their very low cross-sectional height ▶ 886 | 1
- are used if the housing bore is not suitable as a raceway for needle roller and cage assemblies
- can support high radial loads (are pure radial bearings) ▶ 887 | 3, ▶ 888 | 4, ▶ 888 | 5, ▶ 888 | 6
- require a considerably smaller radial design envelope than machined needle roller bearings ▶ 886 | 1
- usually run directly on the shaft (no inner ring) ▶ 886 | 1, ▶ 889 | 7
- permit relatively high speeds
- are easy to mount ▶ 898 | 1.17
- require no additional means of axial retention (as a result of which the housing bore is easy to produce) ▶ 895 | 1.16
- can be readily used to close off the shaft ends of bearing positions (drawn cup needle roller bearings with closed end) ▶ 888 | 6
- result in particularly compact, cost-effective and economical bearing arrangements.

For an overview of other product-specific features, see the Matrix for bearing preselection ▶ 885.

 **1**
Comparison
of radial design envelope



- ① Drawn cup needle roller bearing with open ends and cage
- ② Needle roller bearing with cage

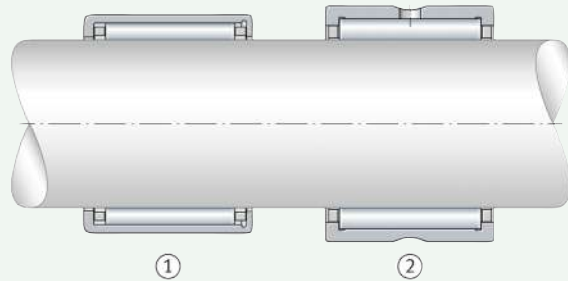

1.1 Bearing design

 Design variants

Drawn cup needle roller bearings with open ends are available as:

- standard drawn cup needle roller bearings with open ends and cage ▶ 887 | 3 and ▶ 888 | 4
- full complement drawn cup needle roller bearings with open ends ▶ 888 | 5
- special bearings ▶ 888 and ▶ 890.

Drawn cup needle roller bearings with closed end are available as:

- standard drawn cup needle roller bearings with closed end ▶888|☐6
- special bearings ▶888 and ▶890
- universal joint bearings ▶888.

Drawn cup needle roller bearings

Drawn cup needle roller bearings are part of the group of radial needle roller bearings. These ready-to-fit bearing arrangement elements are rolling bearings with a very small radial section height. They comprise thin-walled, drawn outer cups and needle roller and cage assemblies which together form a complete unit ▶887|☐2, ▶887|☐3, ▶888|☐5, ▶888|☐6. The cage guides the needle rollers parallel to the axis in pockets.

☞ The outer cups are thin-walled and produced by forming methods

☞ For bearing arrangements with a very small radial design envelope

☞ Drawn cup needle roller bearings can also be combined with inner rings IR or LR

Due to the thin-walled outer cup and the absence of an inner ring, the bearings have a very low cross-sectional height ▶886|☐1. As a result, they are particularly suitable for applications with a very small radial design envelope. The majority of the bearings are of a single row design and do not have a lubrication hole.

Due to the absence of an inner ring, drawn cup needle roller bearings require a hardened and ground bearing raceway on the shaft ▶895|1.16. If the shaft cannot be produced as a rolling bearing raceway, the bearings can be combined with inner rings IR or LR ▶887|☐2. If wider inner rings are used, these can also serve as the running surface for sealing rings G and SD ▶887|☐2.



Drawn cup needle roller bearings with open ends and inner ring

- ① Drawn cup needle roller bearing with open ends
- ② Standard inner ring
- ③ Wider inner ring
- ④ Sealing ring G

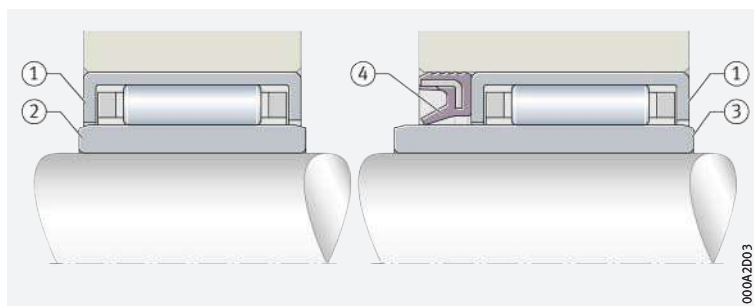

☞ In contrast to drawn cup needle roller bearings with closed end, the bearings are open

Standard drawn cup needle roller bearings with open ends and cage

Drawn cup needle roller bearings of this design are open at both ends and have the basic designation HK ▶887|☐3 and ▶893|1.12. They are supplied with needle roller and cage assemblies. Bearings with needle roller and cage assemblies allow higher speeds than the full complement designs. The bearings are available in open and sealed versions ▶887|☐3 and ▶890|1.5. Double row designs have a lubrication hole in the outer cup and the suffix ZW ▶888|☐4.



Single row drawn cup needle roller bearings with open ends

F_r = radial load

- ① Single row drawn cup needle roller bearing with open ends, open version
- ② Single row drawn cup needle roller bearing with open ends, sealed on both sides

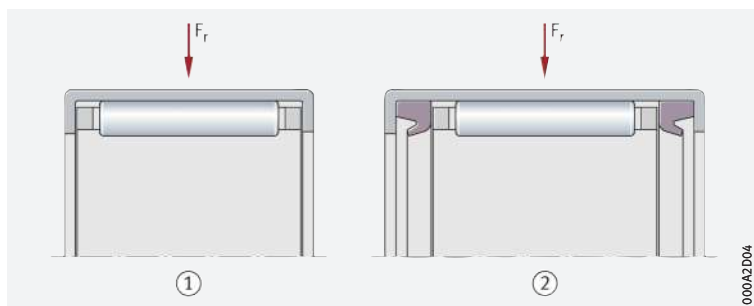

4
 Double row drawn cup
 needle roller bearing
 with open ends

- F_r = radial load
 ① Lubrication hole

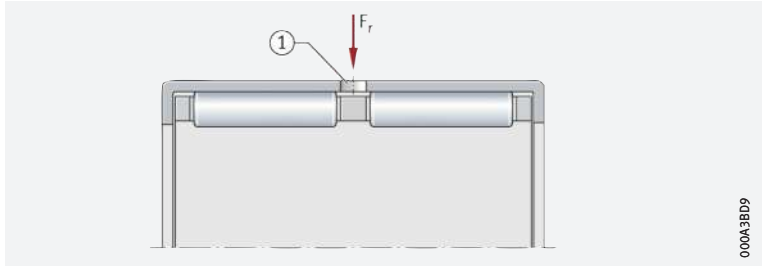

000A3BD9

Particularly high load carrying capacity within a very small radial design envelope

Full complement drawn cup needle roller bearings with open ends

Full complement drawn cup needle roller bearings with open ends have the basic designation HN ▶888| ⑤. As these bearings have the maximum number of needle rollers, they offer extremely high load carrying capacity. However, they do not permit the speeds that are possible when drawn cup needle roller bearings with open ends are used in conjunction with rolling elements retained by a cage.

5
 Full complement drawn cup
 needle roller bearing
 with open ends

- F_r = radial load

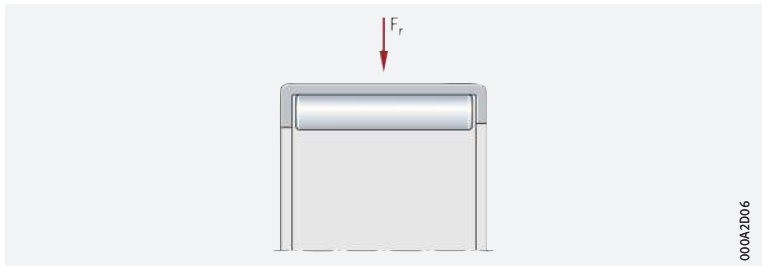

000A2D06

In contrast to drawn cup needle roller bearings with open ends, the bearings are closed at one end

Drawn cup needle roller bearings with closed end

Drawn cup needle roller bearings of this design are closed at one end ▶888| ⑥. They are thus suitable for closing off the shaft ends of bearing positions. This gives protection against injury by rotating shafts and protects the bearings against contamination and moisture. Depending on the size, the base is either smooth or lock-beaded (stiffened). The profiled base can also support small axial guidance forces. Drawn cup needle roller bearings with closed end are available in open and sealed versions ▶888| ⑥ and ▶890|1.5.

6
 Drawn cup needle roller bearings
 with closed end

- F_r = radial load
 ① Drawn cup needle roller bearing with closed end, open version
 ② Drawn cup needle roller bearing with closed end, sealed version

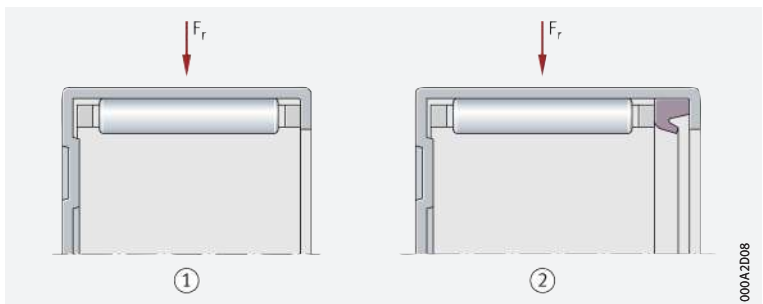

000A2D08

Special bearings



In addition to the standard catalogue range, special designs are available by agreement:

- with enveloping circle F_w from 2 mm to 100 mm
- for special noise requirements (bearings with special noise testing).

Universal joint bearings



For universal joints, universal joint bearings of series BU and BBU are available by agreement.

1.2 Load carrying capacity

The bearings are pure radial bearings

Drawn cup needle roller bearings can support high radial forces, but may only be subjected to radial load. If the bearing position is also required to support axial forces, the bearings can, for example, be combined with axial needle roller bearings AXW ▶889| 7.



Drawn cup needle roller bearing with open ends combined with axial needle roller bearing

F_r = radial load
 F_a = axial load

- ① Drawn cup needle roller bearing with open ends HK (for supporting radial loads)
- ② Axial needle roller bearing AXW (for supporting axial loads)

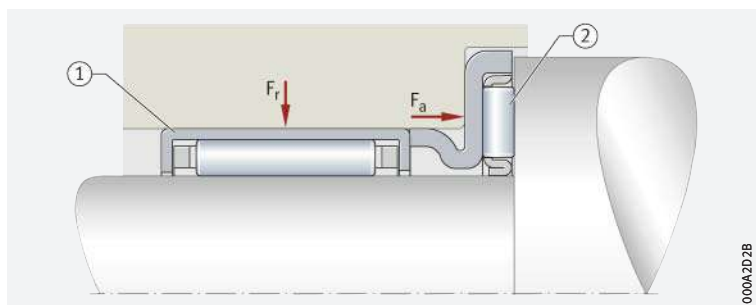

000A2D2B

1.3 Compensation of angular misalignments

The bearings are not suitable for the compensation of shaft misalignments relative to the housing

Drawn cup needle roller bearings are not suitable for the compensation of angular misalignments. The extent to which a misalignment of the shaft can be tolerated relative to the housing bore is dependent on factors such as the design of the bearing position, the size of the bearing, the operating clearance and the load. For this reason, it is not possible to give a guide value for misalignment.



In all cases, misalignments cause increased running noise, place increased strain on the cages and have a harmful influence on the operating life of the bearings.

1.4 Lubrication

Greased bearings

Sealed bearings are greased with a lithium complex soap grease to GA08. The grease filling is measured so that it is sufficient for the entire operating life of the bearing. As a result, the bearings are maintenance-free.



Greased bearings should not be washed out or heated to temperatures of $> +80\text{ }^\circ\text{C}$ prior to mounting.

Ungreased bearings

Ungreased bearings must be lubricated with oil or grease. The majority of single row bearings do not have a lubrication hole.

Compatibility with plastic cages

When using bearings with plastic cages, compatibility between the lubricant and the cage material must be ensured if synthetic oils, lubricating greases with a synthetic oil base or lubricants containing a high proportion of EP additives are used.

Observe oil change intervals

Aged oil and additives in the oil can impair the operating life of plastics at high temperatures. As a result, stipulated oil change intervals must be strictly observed.

Lubrication of full complement drawn cup needle roller bearings with open ends



The needle rollers are retained by a special grease

Since the needle rollers in full complement bearings are not retained by mechanical means (no cage is present), they are retained for transport and fitting by means of a special grease (DIN 51825-K1/2K-30). However, this grease does not have an adequate long term lubrication capacity. Relubrication is therefore recommended after fitting.



If there is any uncertainty regarding relubrication, please consult Schaeffler.

Bearings of special design



The following special designs are available by agreement:

- unsealed bearings, greased using a lithium complex soap grease to GA08 (suffix GA08)
- bearings with a lubrication hole for sizes from HK0609 (suffix AS1).

1.5

Sealing

The bearings are open or sealed

Drawn cup needle roller bearings are available in an open design in accordance with DIN 618:2008 (ISO 3245:2015) and a sealed design in accordance with DIN 618:2008.

Integrated seals are particularly space-saving

Sealed bearings

Under normal operating conditions, contact seals give protection against contamination, spray water and the loss of lubricant. The integration of such seals into the bearing provides a compact, reliable, proven and economical sealing solution.

Provide seals in the adjacent construction

Unsealed bearings

In the case of unsealed bearings, sealing of the bearing position must be carried out in the adjacent construction. This must reliably prevent:

- moisture and contaminants from entering the bearing
- the egress of lubricant from the bearing.

Effective sealing elements for use in sealing open bearings

Sealing of the bearing position with sealing rings G or SD

Bearing positions with open drawn cup needle roller bearings can be sealed economically using sealing rings G or SD. The sealing rings are designed as contact seals and are arranged in front of the bearing $\blacktriangleright 887 \text{ | } \text{⊕} 2$, $\blacktriangleright 890 \text{ | } \text{⊕} 8$. They are suitable for circumferential velocities at the running surface of up to 10 m/s and protect the bearing position reliably against contamination, spray water and excessive loss of lubricant. The sealing rings are matched to the low radial dimensions of drawn cup needle roller bearings with open ends. They are very easy to fit, since they are simply pressed into the housing bore.



Sealing of the bearing position with sealing rings G or SD

- ① Drawn cup needle roller bearing with open ends, open version
- ② Sealing ring G
- ③ Sealing ring SD

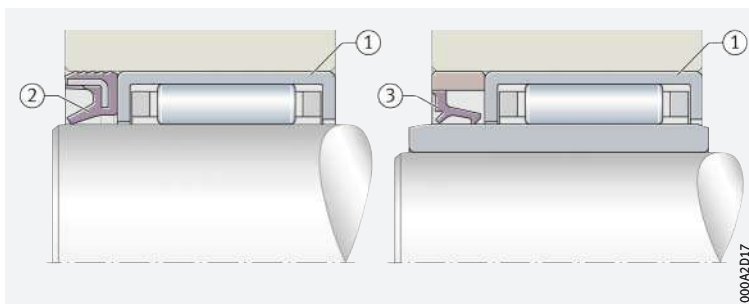

000A2D17

1.6 Speeds

🔗 *Limiting speeds and reference speeds in the product tables*

Two speeds are generally indicated in the product tables ▶ 900 | :

- the kinematic limiting speed n_G
- the thermal speed rating $n_{\vartheta r}$.

Limiting speed



The limiting speed n_G is the kinematically permissible speed of a bearing. Even under favourable mounting and operating conditions, this value should not be exceeded without prior consultation with Schaeffler ▶ 64. The values in the product tables are valid for oil lubrication.

🔗 *Values for grease lubrication*

For the grease lubrication of open cage bearings, 60% of the value stated in the product tables is permissible in each case.

🔗 *Speeds for full complement bearings*

Due to the bearing kinematics and higher temperatures within the bearing, the speeds for full complement bearings are lower than for bearings with a cage.

Reference speeds

🔗 *$n_{\vartheta r}$ is used to calculate n_{ϑ}*

The thermal speed rating $n_{\vartheta r}$ is not an application-oriented speed limit, but is a calculated ancillary value for determining the thermally safe operating speed n_{ϑ} ▶ 64.

🔗 *Bearings with contact seals*

For bearings with contact seals, no reference speeds are defined in accordance with DIN ISO 15312:2004. As a result, only the limiting speed n_G is given in the product tables for these bearings.

1.7 Noise

Schaeffler Noise Index

The Schaeffler Noise Index (SGI) is not yet available for this bearing type ▶ 69. The data for these bearing series will be introduced and updated in stages.

Further information:

■ **medias** ▶ <https://medias.schaeffler.com>.

1.8 Temperature range

🔗 *Limiting values*

The operating temperature of the bearings is limited by:

- the dimensional stability of the bearing rings and rolling elements
- the cage
- the lubricant
- the seals.

Possible operating temperatures of drawn cup needle roller bearings ▶ 891 |  1.

 **1**
Permissible temperature ranges

Operating temperature	Open drawn cup needle roller bearings		Sealed drawn cup needle roller bearings
	with sheet steel cage or full complement	with polyamide cage PA66	
	-30 °C to +140 °C	-20 °C to +120 °C	-20 °C to +100 °C, limited by the lubricant and seal material



In the event of anticipated temperatures which lie outside the stated values, please contact Schaeffler.



1.9 Cages

 *Sheet steel cages are used as standard*

With only a few exceptions, the cages are made from sheet steel. Bearings with a plastic cage have the suffix TV. Other cage designs are available by agreement. With such cages, however, suitability for high speeds and temperatures as well as the basic load ratings may differ from the values for the bearings with standard cages.



For high continuous temperatures and applications with difficult operating conditions, bearings with sheet steel cages should be used. If there is any uncertainty regarding cage suitability, please consult Schaeffler.

1.10 Internal clearance

 *The enveloping circle diameter F_w applies instead of the radial internal clearance*

In the case of bearings without an inner ring, the dimension for the inner enveloping circle diameter F_w is used instead of the radial internal clearance. The enveloping circle is the inner inscribed circle of the needle rollers in clearance-free contact with the outer raceway. Once the bearings are mounted, the inner enveloping circle diameter F_w is approximately in tolerance class F8. The precondition for this is that the bore tolerances are observed for bearings without an inner ring ▶ 895 | 1.16, ▶ 896 | 6 and ▶ 895 | 4.

Checking the enveloping circle diameter F_w

 *F_w can only be checked in a mounted condition*

In the case of drawn cup needle roller bearings, the inner enveloping circle diameter F_w can only be checked once the bearings are mounted. In order to carry out the check, the bearing is pressed into a steel ring gauge, which has a cylindrical bore with the nominal dimension D and lower deviation of tolerance class N6 (in accordance with ISO 286-2). The ring gauge must have a minimum wall thickness of 20 mm, the minimum width must correspond to the width of the bearing. A plug gauge to ISO 1132-2 is used for checking purposes. The tolerance class of the enveloping circle is within the range of values defined in the table ▶ 893 | 2.

Example

 *Example of checking of F_w*

For drawn cup needle roller bearing with open ends HK1010 ($F_w = 10$ mm), F_w must be between 10,013 mm and 10,031 mm, the ring gauge bore must be 13,980 mm (lower deviation = +13 μ m, upper deviation = +31 μ m) ▶ 893 | 2.



Bearings intended for enveloping circle measurements should not be repeatedly pushed in and out of the gauge. Bearings that have been checked in the ring gauge should not be used again.

 **2**
 Ring gauge bore and
 enveloping circle deviations
 (to DIN 618:2008)

Enveloping circle F_w mm	Outside diameter D mm	Ring gauge bore mm	Enveloping circle deviation	
			Upper μm	Lower μm
2	4,6	4,587	+24	+6
3	6,5	6,484	+24	+6
4	8	7,984	+28	+10
5	9	8,984	+28	+10
6	10	9,984	+28	+10
7	11	10,980	+31	+13
8	12	11,980	+31	+13
9	13	12,980	+31	+13
10	14	13,980	+31	+13
12	16	15,980	+34	+16
12	18	17,980	+34	+16
13	19	18,976	+34	+16
14	20	19,976	+34	+16
15	21	20,976	+34	+16
16	22	21,976	+34	+16
17	23	22,976	+34	+16
18	24	23,976	+34	+16
20	26	25,976	+41	+20
22	28	27,976	+41	+20
25	32	31,972	+41	+20
28	35	34,972	+41	+20
30	37	36,972	+41	+20
32	39	38,972	+50	+25
35	42	41,972	+50	+25
40	47	46,972	+50	+25
45	52	51,967	+50	+25
50	58	57,967	+50	+25
55	63	62,967	+60	+30
60	68	67,967	+60	+30

1.11 Dimensions, tolerances

Dimension standards



The main dimensions of the bearings correspond to DIN 618:2008 and ISO 3245:2015, where standardised. Nominal dimensions of bearings \blacktriangleright 900 .

Tolerances



The tolerances correspond to DIN 618:2008 (ISO 3245:2015), where standardised. The inner enveloping circle diameter F_w is approximately in tolerance class F8 \blacktriangleright 892  1.10.

1.12 Suffixes

For a description of the suffixes used in this chapter \blacktriangleright 893  3 and **medias** interchange \blacktriangleright <https://www.schaeffler.de/std/1D52>.

 **3**
 Suffixes and
 corresponding descriptions

Suffix	Description of suffix	
AS1	With lubrication hole from HK0609	Special design, available by agreement
GA08	Unsealed, greased bearings for operating temperatures from $-20\text{ }^\circ\text{C}$ to $+140\text{ }^\circ\text{C}$	
RS	Contact seal on one side	Standard
TV	Cage made from glass fibre reinforced polyamide PA66	
ZW	Double row design, with lubrication hole	
2RS	Contact seal on both sides	



1.13 Structure of bearing designation

The designation of bearings follows a set model.
Examples ▶ 894 | 9 and ▶ 894 | 10. The composition of designations is subject to DIN 623-1 ▶ 102 | 10.

9
Drawn cup needle roller bearing with closed end, open version: designation structure

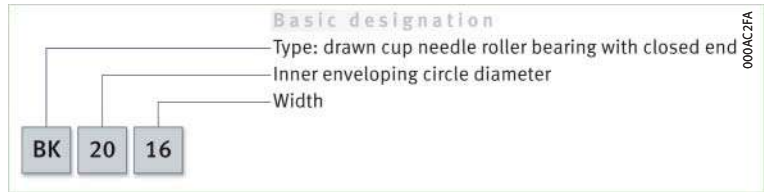

10
Drawn cup needle roller bearing with open ends, sealed on both sides: designation structure

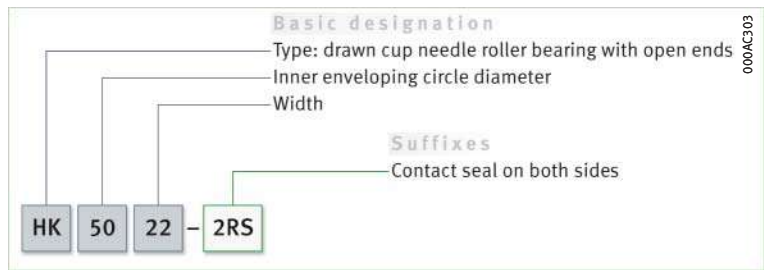

1.14 Dimensioning

$P = F_r$ under purely radial load of constant magnitude and direction

Equivalent dynamic bearing load

The basic rating life equation $L = (C_r/P)^P$ used in the dimensioning of bearings under dynamic load assumes a load of constant magnitude and direction. In radial bearings, this is a purely radial load F_r ▶ 889 | 1.2. The bearing load F_r is therefore used in the rating life equation for P ($P = F_r$) ▶ 894 | 1.

f1
Equivalent dynamic load

$$P = F_r$$

Legend

P	N	Equivalent dynamic bearing load
F_r	N	Radial load.

Equivalent static bearing load

For drawn cup needle roller bearings subjected to static load ▶ 894 | 2.

f2
Equivalent static load

$$P_0 = F_{0r}$$

Legend

P_0	N	Equivalent static bearing load
F_{0r}	N	Largest radial load present (maximum load).

Static load safety factor

$S_0 = C_0/P_0$ In addition to the basic rating life L_{10h} , it is also always necessary to check the static load safety factor S_0 ▶ 894 | 3. For drawn cup needle roller bearings, $S_0 \geq 3$ is necessary.

f3
Static load safety factor

$$S_0 = \frac{C_0}{P_0}$$

Legend

S_0	-	Static load safety factor
C_0	N	Basic static load rating
P_0	N	Equivalent static bearing load.

1.15 Minimum load

In order to prevent damage due to slippage, a minimum radial load of $P > C_{0r}/60$ is required

In order that no slippage occurs between the contact partners, the drawn cup needle roller bearings must be constantly subjected to a sufficiently high load. Based on experience, a minimum radial load of the order of $P > C_{0r}/60$ is thus necessary. In most cases, however, the radial load is already higher than the requisite minimum load due to the weight of the supported parts and the external forces.



If the minimum radial load is lower than indicated above, please consult Schaeffler.

1.16 Design of bearing arrangements

Radial location of bearings

Support outer cup/ inner ring over entire circumference and width

In order to allow full utilisation of the load carrying capacity of the bearings and achieve the requisite rating life, sufficient rigid support must be provided for the thin-walled outer cups in the housing. Due to the thin-walled outside surface, the bearings only adopt their precise geometry once they have a tight fit. The support for the outer cup in the housing bore can be produced as a cylindrical seating surface. The seating surfaces for the outer cup and the raceway for the rolling elements or inner ring (if the bearing arrangement is not produced as a direct bearing arrangement) should not be interrupted by grooves, holes or other recesses. The accuracy of the mating parts must meet specific requirements, the bore tolerances for the housing bore (recommended tolerance classes) are dependent on the housing material ▶ 895 | 4. If the housings are not rigid, tests must be carried out to determine which shaft tolerance the desired operating clearance will be achieved with. Numerical values for IT grades ▶ 895 | 5. For the bearings to be mounted without damage, the shaft must have a lead chamfer of 10° to 15°.

4
Tolerance classes and surface design for housings, as a function of the material

Housing material	Bore tolerance to ISO 286-2	Roundness tolerance	Parallelism tolerance	Recommended mean roughness value R _{max} (R _{Zmax}) µm
Steel or cast iron	N6 ⑥	max. IT5/2	max. IT5/2	0,8 (4)
Aluminium (Al)	R6 ⑥			
Magnesium (Mg)	S6 ⑥			

5
Numerical values for ISO standard tolerances (IT grades) to ISO 286-1:2010

IT grade	Nominal dimension in mm						
	over	3	6	10	18	30	50
	incl.	3	6	10	18	30	50
Values in µm							
IT3	2	2,5	2,5	3	4	4	5
IT4	3	4	4	5	6	7	8
IT5	4	5	6	8	9	11	13

Axial location of bearings

A tight fit is usually sufficient for axial location

If axial locating elements such as shoulders and snap rings are not used, the housing bore can be produced easily and particularly economically. This also gives simplified mounting of the bearings.



☞ Produce the raceway as a rolling bearing raceway

Raceway for bearing arrangements without an inner ring (direct bearing arrangement)

Where drawn cup needle roller bearings run directly on the shaft (without an inner ring), the raceway for the rolling elements must be produced as a rolling bearing raceway (hardened and ground). Design of raceways ▶ 896 | 6. The values in the table refer to commonly encountered application examples. If the shaft cannot be produced as a raceway, the bearings can be combined with Schaeffler bearing rings. However, the section height of the bearings will then be increased by the thickness of the rings.

6
 Tolerance class and surface design for the shaft (direct bearing arrangement)

Shaft tolerance to ISO 286-2	Roundness tolerance	Parallelism tolerance	Recommended mean roughness value Ramax (Rzmax) μm
h6 ⑥	max. IT3	max. IT3	0,2 (1)

Steels for the raceway (direct bearing arrangement)

Through hardening steels



Through hardening steels in accordance with ISO 683-17 (e.g. 100Cr6) are suitable as materials for rolling bearing raceways in direct bearing arrangements. These steels can also be surface layer hardened.

Case hardening steels



Case hardening steels normally correspond to ISO 683-17 (such as 17MnCr5, 18CrNiMo7-6) or EN 10084 (such as 16MnCr5).

Steels for inductive surface layer hardening



For flame and induction hardening, steels in accordance with ISO 683-17 (such as C56E2, 43CrMo4) or DIN 17212 (such as Cf53) should be used.

Surface hardness and hardening depth

☞ Nominal surface hardness: $\geq 670 \text{ HV}$

The requisite minimum surface hardness of 670 HV is valid for raceways, axial washers and shaft shoulders. Steels hardened by means of case, flame or induction hardening must have a surface hardness of 670 HV to 840 HV and an adequate hardening depth CHD or SHD.

Raceway softer than 670 HV



If the raceway fulfils the requirements for rolling bearing materials but is softer than 670 HV, the load on the bearing arrangement cannot be as high as the full load carrying capacity of the bearing. In order to determine the dynamic and static load carrying capacity of the bearing arrangement, the basic dynamic load rating C of the bearings must be multiplied by the reduction factor f_H (dynamic hardness factor) and the basic static load rating C_{0r} by the reduction factor f_{H0} (static hardness factor) ▶ 896 | 11 and ▶ 897 | 12.

11
 Dynamic hardness factor at reduced hardness of raceways/rolling elements

f_H = dynamic hardness factor
 HV, HRC = surface hardness

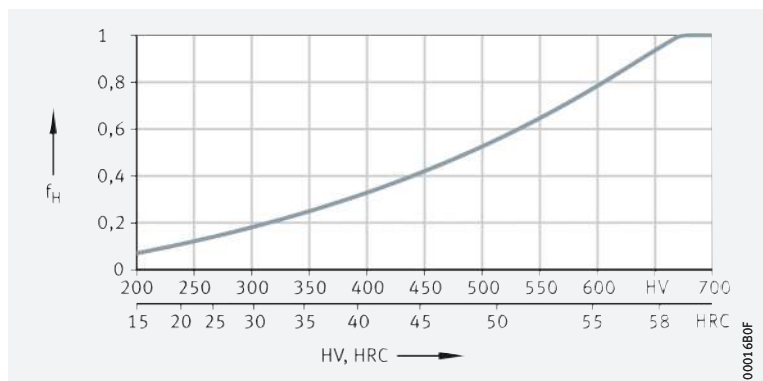

12

Static hardness factor at reduced hardness of raceways/rolling elements

f_{H0} = static hardness factor
 HV, HRC = surface hardness

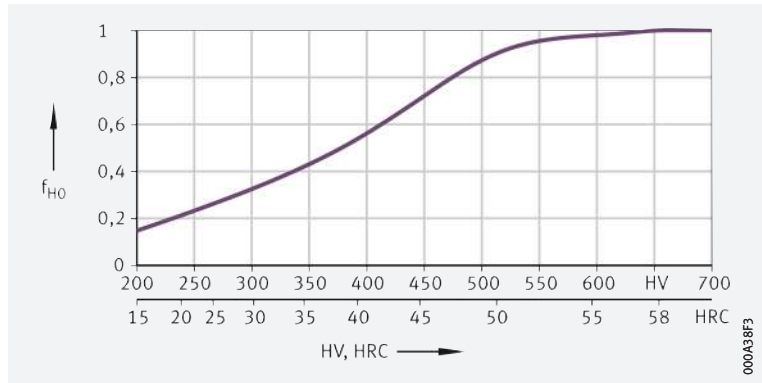

Determining the case hardening depth

Approximation value for case hardening depth

In order to obtain an approximation value for defining the minimum hardening depth, the relationship in accordance with ▶ 180 | 5 can be used as a basis. The reference value for the load present is the equivalent stress in accordance with the distortion energy hypothesis (DEH) as a function of the rolling element diameter D_w and the magnitude of the load.

f 4
 Case hardening depth

$$CHD \geq 0,052 \cdot D_w$$

Legend

CHD	mm	Case hardening depth
D_w	mm	Rolling element diameter.



The local hardness must always be above the local requisite hardness, which can be calculated from the equivalent stress.

Determining the surface hardening depth



In these surface hardening methods, the load and contact geometry must be taken into consideration when determining the requisite hardening depth.

Determining the surface hardening depth

The rule of thumb for calculating the surface hardening depth SHD is the relationship in accordance with ▶ 181 | 6.

f 5
 Surface hardening depth

$$SHD \geq 140 \cdot D_w / R_{p0,2}$$

Legend

SHD	mm	Surface hardening depth
D_w	mm	Rolling element diameter
$R_{p0,2}$	N/mm ²	Yield point of base material.



1.17 Mounting and dismounting

☞ *Ensure that the bearings are not damaged during mounting*

The bearings are self-retaining (not separable). They are mounted using a special fitting mandrel ▶ 898 | 13. The shoulder of the fitting mandrel must rest against the marked end face (designation) of the bearing. A toroidal ring should be used to retain the bearing. The length and oversize of the ring must be matched by the customer to the dimensions and mass of the bearing. The press-in forces occurring during mounting are dependent on several factors. Mounting must be carried out so that the bearing rib on the end face is not deformed. If the application requires a mounting procedure different from the one described, mounting trials must be carried out in order to ensure that the bearings can be mounted correctly and without causing damage.



Drawn cup needle roller bearings must not be tilted during pressing-in, as this may damage the bearing. If grease lubrication is to be used, the bearings should be lubricated with grease before mounting.

13
 Mounting of a drawn cup needle roller bearing with open ends using a fitting mandrel: design of the fitting mandrel

General tolerances to ISO 2768-1

F_w = inner enveloping circle diameter

D = bearing outside diameter

R = radii of fitting mandrel

① Toroidal ring

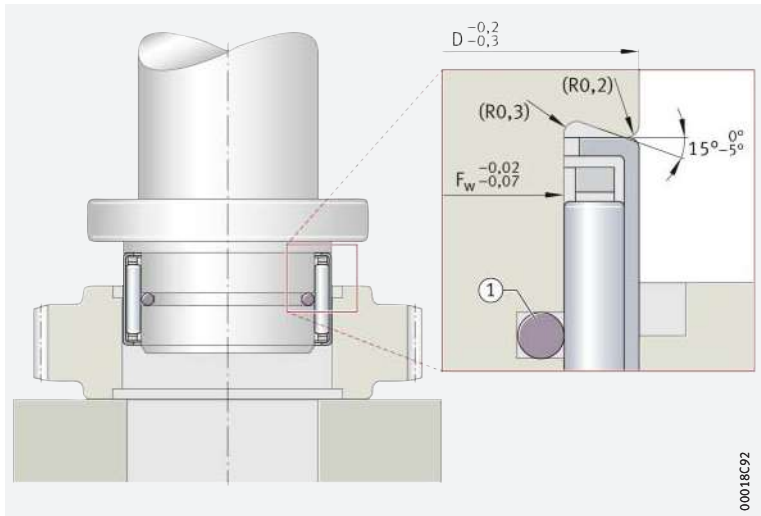

Schaeffler Mounting Handbook

☞ *Rolling bearings must be handled with great care*

Rolling bearings are well-proven precision machine elements for the design of economical and reliable bearing arrangements, which offer high operational security. In order that these products can function correctly and achieve the envisaged operating life without detrimental effect, they must be handled with care.



The Schaeffler Mounting Handbook MH 1 gives comprehensive information about the correct storage, mounting, dismounting and maintenance of rotary rolling bearings ▶ <https://www.schaeffler.de/std/1D53>. It also provides information which should be observed by the designer, in relation to the mounting, dismounting and maintenance of bearings, in the original design of the bearing position. This book is available from Schaeffler on request.

1.18 Legal notice regarding data freshness

The further development of products may also result in technical changes to catalogue products

Of central interest to Schaeffler is the further development and optimisation of its products and the satisfaction of its customers. In order that you, as the customer, can keep yourself optimally informed about the progress that is being made here and with regard to the current technical status of the products, we publish any product changes which differ from the printed version in our electronic product catalogue.



We therefore reserve the right to make changes to the data and illustrations in this catalogue. This catalogue reflects the status at the time of printing. More recent publications released by us (as printed or digital media) will automatically precede this catalogue if they involve the same subject. Therefore, please always use our electronic product catalogue to check whether more up-to-date information or modification notices exist for your desired product.

Link to electronic product catalogue



The following link will take you to the Schaeffler electronic product catalogue: ► <https://medias.schaeffler.com>.

1.19 Further information



In addition to the data in this chapter, the following chapters in Technical principles must also be observed in the design of bearing arrangements:

- Determining the bearing size ► 34
- Rigidity ► 54
- Friction and increases in temperature ► 56
- Speeds ► 64
- Bearing data ► 97
- Lubrication ► 70
- Sealing ► 182
- Design of bearing arrangements ► 139
- Mounting and dismounting ► 191.





Drawn cup needle roller bearings with open ends
Drawn cup needle roller bearings with closed end
 Unsealed

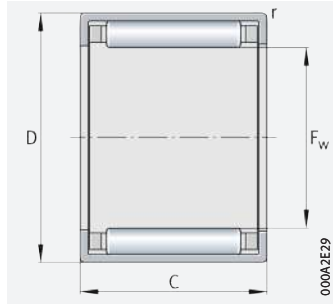

HK

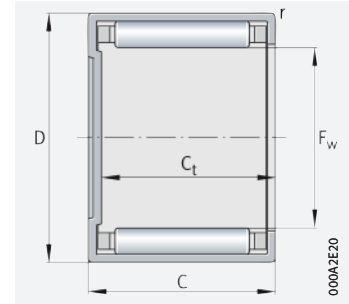

BK

$F_w = 2 - 16 \text{ mm}$

Main dimensions			Basic load ratings		Fatigue limit load	Limiting speed	Speed rating	Drawn cup needle roller bearings with open ends		Drawn cup needle roller bearings with closed ends		
F_w	D	C	dyn. C_r	stat. C_{0r}	C_{ur}	n_G	$n_{\partial r}$	Mass m	Designation	Mass m	Designation	
		-0,3	N	N	N	min^{-1}	min^{-1}	$\approx \text{g}$	► 893 1.12 ► 894 1.13	$\approx \text{g}$	► 893 1.12 ► 894 1.13	
2	4,6	5	465	265	28,5	58 000	93 000	0,3	HK0205-TV ¹⁾	-	-	
3	6,5	6	1 230	840	85	48 000	57 000	1	HK0306-TV ¹⁾	1	BK0306-TV ¹⁾	
4	8	8	1 780	1 310	144	42 500	44 500	1,5	HK0408 ¹⁾	1,6	BK0408 ¹⁾	
5	9	9	2 400	1 990	239	39 000	36 500	2	HK0509 ¹⁾	2,1	BK0509 ¹⁾	
	6	10	6	1 610	1 220	167	36 500	31 500	1,5	HK0606 ¹⁾	-	-
		10	8	2 030	1 650	184	36 500	31 500	2,1	HK0608 ¹⁾	-	-
7	11	9	3 100	2 950	355	33 000	26 500	2,6	HK0709	2,6	BK0609	
	8	12	8	2 750	2 600	290	29 500	23 800	2,7	HK0808	3	BK0808
		12	10	3 800	3 950	500	29 500	23 200	3	HK0810	3,4	BK0810
9	13	8	3 550	3 750	440	26 500	20 600	3	HK0908	-	-	
	13	10	4 250	4 650	600	26 500	20 600	4	HK0910	4,3	BK0910	
	13	12	5 300	6 300	860	26 500	20 200	4,6	HK0912	4,9	BK0912	
10	14	10	4 400	5 100	650	24 300	18 700	4,1	HK1010	4,3	BK1010	
	14	12	5 500	6 800	930	24 300	18 400	4,8	HK1012	5	BK1012	
	14	15	6 800	8 800	1 210	24 300	18 200	6	HK1015	6,2	BK1015	
12	16	10	4 950	6 200	800	20 700	15 700	4,6	HK1210	5,2	BK1210	
	18	12	6 500	7 300	860	20 000	15 500	9	HK1212	10	BK1212	
	18	16	9 300	11 500	1 420	20 000	15 100	13	HK1216	-	-	
13	19	12	6 800	7 900	940	18 700	14 400	10	HK1312	11	BK1312	
14	20	12	7 100	8 500	1 010	17 500	13 500	10,5	HK1412	12	BK1412	
	15	21	12	7 900	9 400	1 150	16 300	12 300	11	HK1512	13	BK1512
21		16	10 500	14 400	1 780	16 500	12 300	15	HK1516	17	BK1516	
21		22	13 400	19 500	2 380	16 500	12 300	20	HK1522-ZW	-	-	
16	22	12	7 600	9 700	1 160	15 600	11 900	12	HK1612	14	BK1612	
	22	16	10 900	15 300	1 900	15 600	11 600	16	HK1616	18	BK1616	
	22	22	13 100	19 400	2 310	15 600	11 700	22	HK1622-ZW	24	BK1622-ZW	

medias ► <https://www.schaeffler.de/std/1F15>

- 1) Not available with lubrication hole.
- 2) For unsealed drawn cup needle roller bearings, dimensionally matched sealing rings of series G or SD can be used to provide protection against contamination.



Dimensions			Suitable inner rings ▶ 992		Suitable sealing rings ²⁾ ▶ 1026	
F_w	C_t	r	LR designation	IR designation		
	min.	min.				
2		0,3	-	-	-	-
3	5,2	0,3	-	-	-	-
4	6,4	0,3	-	-	GR4×8×2	-
5	7,4	0,4	-	-	GR5×9×2	-
6	-	0,4	-	-	GR6×10×2	-
	-	0,4	-	-	GR6×10×2	-
7	7,4	0,4	-	-	GR6×10×2	-
	7,4	0,4	-	-	GR7×11×2	-
8	6,4	0,4	-	-	-	G8×12×3
	8,4	0,4	-	IR5×8×12-XL	-	G8×12×3
9	-	0,4	-	-	GR9×13×3	G9×13×3
	8,4	0,4	-	-	GR9×13×3	G9×13×3
	10,4	0,4	-	IR6×9×12-XL	GR9×13×3	G9×13×3
10	8,4	0,4	LR7×10×10,5	IR7×10×10,5-XL	GR10×14×3	G10×14×3
	10,4	0,4	-	IR7×10×12-XL	GR10×14×3	G10×14×3
	13,4	0,4	-	IR7×10×16-XL	GR10×14×3	G10×14×3
12	8,4	0,4	LR8×12×10,5	IR8×12×10,5-XL	SD12×18×3	G12×18×3
	9,3	0,8	LR8×12×12,5	IR8×12×12,5-XL	SD12×18×3	G12×18×3
	-	0,8	-	IR9×12×16-XL	SD12×18×3	G12×18×3
13	9,3	0,8	LR10×13×12,5	IR10×13×12,5-XL	-	G13×19×3
14	9,3	0,8	-	IR10×14×13-XL	SD14×20×3	G14×20×3
15	9,3	0,8	LR12×15×12,5	IR12×15×12-XL	SD15×21×3	G15×21×3
	13,3	0,8	LR12×15×16,5	IR12×15×16-XL	SD15×21×3	G15×21×3
	-	0,8	LR12×15×22,5	IR12×15×22,5-XL	SD15×21×3	G15×21×3
16	9,3	0,8	-	IR12×16×13-XL	SD16×22×3	G16×22×3
	13,3	0,8	-	IR12×16×16-XL	SD16×22×3	G16×22×3
	19,3	0,8	-	IR12×16×22-XL	SD16×22×3	G16×22×3





Drawn cup needle roller bearings with open ends
Drawn cup needle roller bearings with closed end
 Unsealed

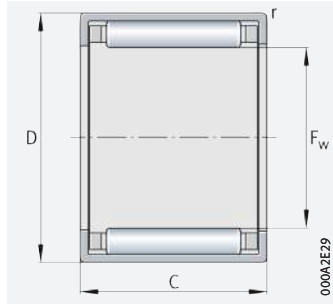

HK

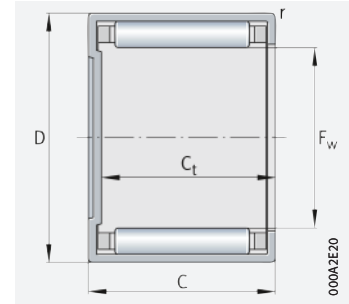

BK with $F_w < 25 \text{ mm}$

$F_w = 17 - 30 \text{ mm}$

Main dimensions			Basic load ratings		Fatigue limit load	Limiting speed	Speed rating	Drawn cup needle roller bearings with open ends		Drawn cup needle roller bearings with closed end	
F_w	D	C	dyn. C_r	stat. C_{0r}	C_{ur}	n_G	$n_{\partial r}$	Mass m	Designation	Mass m	Designation
		-0,3	N	N	N	min^{-1}	min^{-1}	$\approx \text{g}$	$\triangleright 893 1.12$ $\triangleright 894 1.13$	$\approx \text{g}$	$\triangleright 893 1.12$ $\triangleright 894 1.13$
17	23	12	7 900	10 300	1 230	14 700	11 200	12	HK1712	-	-
18	24	12	8 100	10 900	1 300	14 000	10 700	13	HK1812	15	BK1812
	24	16	11 600	17 300	2 140	14 000	10 400	18	HK1816	20	BK1816
20	26	10	6 300	8 100	1 010	12 700	10 000	12	HK2010	-	-
	26	12	8 600	12 100	1 450	12 700	9 700	14	HK2012	-	-
	26	16	12 700	20 100	2 500	12 700	9 300	19	HK2016	22	BK2016
	26	20	15 700	26 000	3 500	12 700	9 300	24	HK2020	27	BK2020
	26	30	21 800	40 000	5 000	12 700	9 200	35	HK2030-ZW	-	-
22	28	10	7 500	10 500	1 360	11 700	9 000	13	HK2210	-	-
	28	12	9 100	13 400	1 600	11 700	8 900	15	HK2212	18	BK2212
	28	16	13 400	22 100	2 800	11 700	8 500	21	HK2216	24	BK2216
	28	20	16 500	29 000	3 850	11 700	8 500	26	HK2220	-	-
25	32	12	11 000	15 200	1 990	10 200	7 800	20	HK2512	-	-
	32	16	15 600	24 000	3 150	10 200	7 500	27	HK2516	32	BK2516
	32	20	19 900	33 000	4 200	10 200	7 400	33	HK2520	38	BK2520
	32	26	25 500	45 000	6 200	10 200	7 300	44	HK2526	48	BK2526
	32	38	34 000	66 000	8 400	10 200	7 300	64	HK2538-ZW	68	BK2538-ZW
28	35	16	16 400	26 500	3 450	9 200	6 800	29	HK2816	-	-
	35	20	20 900	36 000	4 650	9 200	6 700	36	HK2820	-	-
30	37	12	12 100	18 200	2 390	8 600	6 600	23	HK3012	28	BK3012
	37	16	17 200	29 000	3 750	8 600	6 400	31	HK3016	38	BK3016
	37	20	22 000	39 500	5 100	8 600	6 300	39	HK3020	47	BK3020
	37	22	24 800	46 000	6 100	8 600	6 200	42	HK3022	-	-
	37	26	28 000	54 000	7 400	8 600	6 200	51	HK3026	58	BK3026
	37	38	37 500	79 000	10 100	8 600	6 200	76	HK3038-ZW	84	BK3038-ZW

medias \triangleright <https://www.schaeffler.de/std/1F16>

1) For unsealed drawn cup needle roller bearings, dimensionally matched sealing rings of series G or SD can be used to provide protection against contamination.

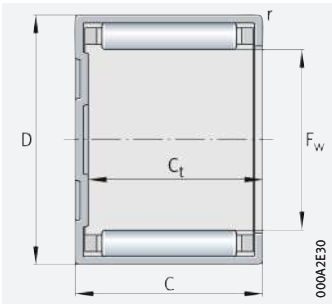

BK with $F_w \geq 25 \text{ mm}$

Dimensions			Suitable inner rings ▶ 992		Suitable sealing rings ¹⁾ ▶ 1026		
F_w	C_t	r	LR designation	IR designation			
	min.	min.					
17	–	0,8	–	–	SD17×23×3	G17×23×3	
18	9,3	0,8	LR15×18×12,5	–	SD18×24×3	G18×24×3	
	13,3	0,8	LR15×18×16,5	IR15×18×16-XL	SD18×24×3	G18×24×3	
20	–	0,8	–	–	SD20×26×4	G20×26×4	
	–	0,8	–	IR15×20×13-XL	SD20×26×4	G20×26×4	
	13,3	0,8	LR17×20×16,5	IR17×20×16-XL	SD20×26×4	G20×26×4	
	17,3	0,8	LR17×20×20,5	IR17×20×20-XL	SD20×26×4	G20×26×4	
22	–	0,8	LR17×20×30,5	IR17×20×30,5-XL	SD20×26×4	G20×26×4	
	–	0,8	–	–	SD22×28×4	G22×28×4	
	9,3	0,8	–	IR17×22×13-XL	SD22×28×4	G22×28×4	
	13,3	0,8	–	IR17×22×16-XL	SD22×28×4	G22×28×4	
25	–	0,8	–	IR17×22×23-XL	SD22×28×4	G22×28×4	
	–	0,8	LR20×25×12,5	–	SD25×32×4	G25×32×4	
	13,3	0,8	LR20×25×16,5	IR20×25×17-XL	SD25×32×4	G25×32×4	
	17,3	0,8	LR20×25×20,5	IR20×25×20-XL	SD25×32×4	G25×32×4	
	23,3	0,8	LR20×25×26,5	IR20×25×26,5-XL	SD25×32×4	G25×32×4	
28	35,3	0,8	LR20×25×38,5	IR20×25×38,5-XL	SD25×32×4	G25×32×4	
	–	0,8	–	IR22×28×17-XL	SD28×35×4	G28×35×4	
	–	0,8	LR22×28×20,5	IR22×28×20-XL	SD28×35×4	G28×35×4	
	30	9,3	0,8	LR25×30×12,5	–	SD30×37×4	G30×37×4
		13,3	0,8	LR25×30×16,5	IR25×30×17-XL	SD30×37×4	G30×37×4
17,3		0,8	LR25×30×20,5	IR25×30×20-XL	SD30×37×4	G30×37×4	
–		0,8	–	–	SD30×37×4	G30×37×4	
30	23,3	0,8	LR25×30×26,5	IR25×30×26,5-XL	SD30×37×4	G30×37×4	
	35,3	0,8	LR25×30×38,5	IR25×30×38,5-XL	SD30×37×4	G30×37×4	





Drawn cup needle roller bearings with open ends
Drawn cup needle roller bearings with closed end
 Unsealed

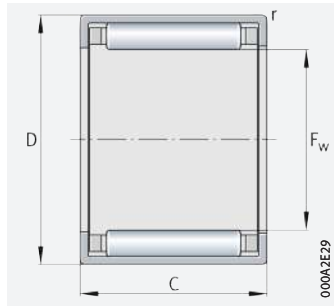

HK

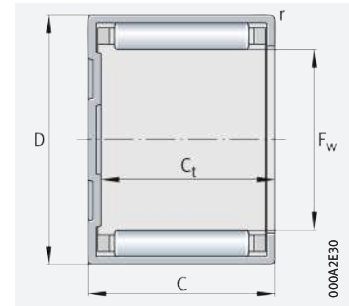

BK

$F_w = 32 - 60 \text{ mm}$

Main dimensions			Basic load ratings		Fatigue limit load	Limiting speed	Speed rating	Drawn cup needle roller bearings with open ends		Drawn cup needle roller bearings with closed end	
F_w	D	C	dyn. C_r	stat. C_{0r}	C_{ur}	n_G	$n_{\partial r}$	Mass m	Designation	Mass m	Designation
		-0,3	N	N	N	min^{-1}	min^{-1}	$\approx \text{g}$	$\triangleright 893 1.12$ $\triangleright 894 1.13$	$\approx \text{g}$	$\triangleright 893 1.12$ $\triangleright 894 1.13$
32	39	20	23 000	42 500	5 500	8 100	5 900	40,6	HK3220	-	-
	39	24	27 500	54 000	7 300	8 100	5 900	49	HK3224	-	-
35	42	12	13 100	21 300	2 800	7 500	5 800	27	HK3512	-	-
	42	16	18 700	33 500	4 400	7 500	5 600	36	HK3516	-	-
	42	20	23 800	46 000	5 900	7 500	5 500	44	HK3520	53	BK3520
40	47	12	14 000	24 300	3 200	6 600	5 200	30	HK4012	-	-
	47	16	20 000	38 500	5 000	6 600	5 000	39	HK4016	-	-
	47	20	25 500	52 000	6 800	6 600	4 900	54	HK4020	62	BK4020
45	52	12	14 900	27 500	3 600	5 900	4 650	33	HK4512	-	-
	52	16	21 300	43 000	5 700	5 900	4 550	46	HK4516	-	-
	52	20	27 000	59 000	7 600	5 900	4 450	56	HK4520	72	BK4520
50	58	20	31 000	63 000	8 200	5 300	4 050	70	HK5020	-	-
	58	25	38 500	84 000	11 700	5 300	4 000	90	HK5025	109	BK5025
55	63	20	31 500	67 000	8 700	4 850	3 800	74	HK5520	-	-
	63	28	44 000	103 000	14 700	4 850	3 700	105	HK5528	-	-
60	68	12	17 400	32 000	4 250	4 450	3 750	49	HK6012	-	-
	68	20	33 500	75 000	9 800	4 450	3 500	81	HK6020	-	-
	68	32	53 000	135 000	19 700	4 450	3 400	136	HK6032	-	-

medias \triangleright <https://www.schaeffler.de/std/1F17>

1) For unsealed drawn cup needle roller bearings, dimensionally matched sealing rings of series G or SD can be used to provide protection against contamination.



Dimensions			Suitable inner rings ▶ 992		Suitable sealing rings ¹⁾ ▶ 1026	
F_w	C_t	r	LR designation	IR designation		
	min.	min.				
32	-	0,8	-	IR28×32×20-XL	-	-
	-	0,8	-	-	-	-
35	-	0,8	LR30×35×12,5	IR30×35×13-XL	SD35×42×4	G35×42×4
	-	0,8	LR30×35×16,5	IR30×35×16-XL	SD35×42×4	G35×42×4
	17,3	0,8	LR30×35×20,5	IR30×35×20-XL	SD35×42×4	G35×42×4
40	-	0,8	LR35×40×12,5	-	SD40×47×4	G40×47×4
	-	0,8	LR35×40×16,5	IR35×40×17-XL	SD40×47×4	G40×47×4
	17,3	0,8	LR35×40×20,5	IR35×40×20-XL	SD40×47×4	G40×47×4
45	-	0,8	-	-	SD45×52×4	G45×52×4
	-	0,8	LR40×45×16,5	IR40×45×17-XL	SD45×52×4	G45×52×4
	17,3	0,8	LR40×45×20,5	IR40×45×20-XL	SD45×52×4	G45×52×4
50	-	0,8	LR45×50×20,5	-	SD50×58×4	G50×58×4
	22,3	0,8	-	IR45×50×25-XL	SD50×58×4	G50×58×4
55	-	0,8	LR50×55×20,5	-	SD55×63×5	G55×63×5
	-	0,8	-	-	SD55×63×5	G55×63×5
60	-	0,8	-	-	-	-
	-	0,8	-	-	-	-
	-	0,8	-	-	-	-





Drawn cup needle roller bearings with open ends

Drawn cup needle roller bearings with closed end

Sealed

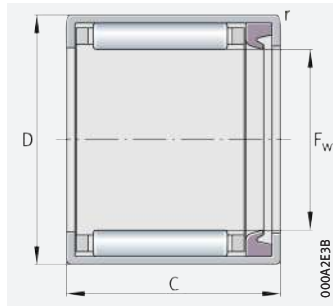

HK...-RS

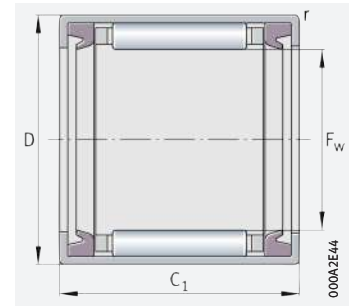

HK...-2RS

F_w = 8 – 50 mm

Main dimensions				Basic load ratings		Fatigue limit load	Limiting speed	Drawn cup needle roller bearings with open ends			
F _w	D	C	C ₁	dyn. C _r	stat. C _{0r}	C _{ur}	n _G grease	Sealed on one side		Sealed on both sides	
				N	N			Mass m	Designation	Mass m	Designation
		-0,3	-0,3			N	min ⁻¹	≈ g		≈ g	
8	12	10	10	2 180	1 930	265	17 700	-	-	3,2	HK0810-2RS
	12	12	12	2 750	2 600	290	17 700	3	HK0810-RS	3,3	HK0812-2RS
	12	12	-	3 800	3 950	500	17 700	3,1	HK0812-RS	-	-
10	14	10	10	2 410	2 330	320	14 600	-	-	4	HK1010-2RS
	14	12	12	3 200	3 350	380	14 600	-	-	4,3	HK1012-2RS
	14	14	14	4 400	5 100	650	14 600	4,2	HK1012-RS	4,6	HK1014-2RS
12	16	14	14	4 950	6 200	800	12 400	-	-	11	HK1214-2RS
	18	16	16	6 500	7 300	860	12 000	10	HK1214-RS	11	HK1216-2RS
14	20	16	16	7 100	8 500	1 010	10 500	12	HK1414-RS	13	HK1416-2RS
	21	16	16	7 800	9 800	1 190	9 900	12	HK1514-RS	15	HK1516-2RS
15	21	20	20	10 500	14 400	1 780	9 900	16	HK1518-RS	18	HK1520-2RS
	22	16	16	7 600	9 700	1 160	9 300	13	HK1614-RS	14	HK1616-2RS
16	22	20	20	10 900	15 300	1 900	9 300	-	-	18	HK1620-2RS
	24	16	16	8 100	10 900	1 300	8 400	14	HK1814-RS	15	HK1816-2RS
20	26	16	16	8 600	12 100	1 450	7 600	-	-	18	HK2016-2RS
	26	20	20	12 700	20 100	2 500	7 600	21	HK2018-RS	23	HK2020-2RS
22	28	16	16	9 100	13 400	1 600	7 000	16	HK2214-RS	18	HK2216-2RS
	28	20	20	13 400	22 100	2 800	7 000	24	HK2218-RS	26	HK2220-2RS
25	32	16	16	11 000	15 200	1 990	6 100	-	-	27	HK2516-2RS
	32	20	20	15 600	24 000	3 150	6 100	29	HK2518-RS	31	HK2520-2RS
	32	24	24	19 900	33 000	4 200	6 100	-	-	40	HK2524-2RS
	32	30	30	25 500	45 000	6 200	6 100	-	-	47	HK2530-2RS
28	35	20	20	16 400	26 500	3 450	5 500	31	HK2818-RS	34	HK2820-2RS
30	37	16	16	12 100	18 200	2 390	5 200	-	-	31	HK3016-2RS
	37	20	20	17 200	29 000	3 750	5 200	37	HK3018-RS	36	HK3020-2RS
	37	24	24	22 000	39 500	5 100	5 200	-	-	44	HK3024-2RS
35	42	16	16	13 100	21 300	2 800	4 500	-	-	32	HK3516-2RS
	42	20	20	18 700	33 500	4 400	4 500	39	HK3518-RS	41	HK3520-2RS
40	47	16	16	14 000	24 300	3 200	3 950	-	-	37	HK4016-2RS
	47	20	20	20 000	38 500	5 000	3 950	45	HK4018-RS	48	HK4020-2RS
45	52	20	20	21 300	43 000	5 700	3 550	50	HK4518-RS	54	HK4520-2RS
50	58	24	24	31 000	63 000	8 200	3 150	76	HK5022-RS	81	HK5024-2RS

medias ► <https://www.schaeffler.de/std/1F18>

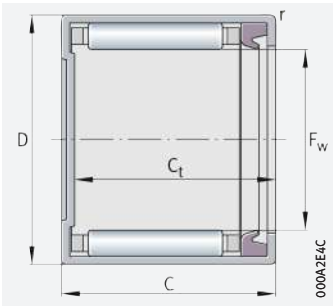

BK..-RS with $F_w < 25 \text{ mm}$

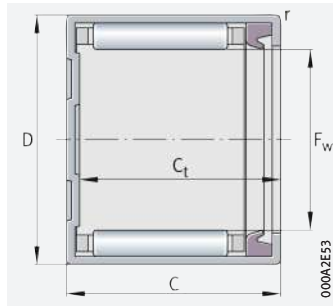

BK..-RS with $F_w \geq 25 \text{ mm}$

F_w	Drawn cup needle roller bearings with closed end Sealed		Dimensions		Suitable inner rings ▶ 992		
	Mass m ≈ g	Designation ▶ 893 1.12 ▶ 894 1.13	C_t min.	r min.	for HK..-RS and HK..-2RS		for BK..-RS
					LR designation	IR designation	Designation
8	-	-	-	0,4	-	-	-
	-	-	-	0,4	-	IR5×8×12-XL	-
	-	-	-	0,4	-	IR5×8×12-XL	-
10	-	-	-	0,4	LR7×10×10,5	IR7×10×10,5-XL	-
	4,3	BK1012-RS	10,4	0,4	-	IR7×10×12-XL	-
	-	-	-	0,4	-	-	-
12	-	-	-	0,8	-	-	-
	-	-	-	0,8	-	IR9×12×16-XL	-
14	13	BK1414-RS	11,3	0,8	-	-	-
15	14	BK1514-RS	11,3	0,8	LR12×15×16,5	IR12×15×16-XL	-
	-	-	-	0,8	-	-	-
16	15	BK1614-RS	11,3	0,8	-	IR12×16×16-XL	IR12×16×13-XL
	-	-	-	0,8	-	IR12×16×20-XL	-
18	-	-	-	0,8	LR15×18×16,5	IR15×18×16-XL	-
20	-	-	-	0,8	LR17×20×16,5	IR17×20×16-XL	-
	24	BK2018-RS	15,3	0,8	LR17×20×20,5	IR17×20×20-XL	-
22	-	-	-	0,8	-	IR17×22×16-XL	-
	-	-	-	0,8	-	IR17×22×23-XL	-
25	-	-	-	0,8	LR20×25×16,5	IR20×25×17-XL	-
	34	BK2518-RS	15,3	0,8	LR20×25×20,5	IR20×25×20-XL	LR20×25×20,5
	-	-	-	0,8	-	-	-
	-	-	-	0,8	-	IR20×25×30-XL	-
28	-	-	-	0,8	LR22×28×20,5	IR22×28×20-XL	-
30	-	-	-	0,8	LR25×30×16,5	IR25×30×17-XL	-
	-	-	-	0,8	LR25×30×20,5	IR25×30×20-XL	-
	-	-	-	0,8	-	-	-
35	-	-	-	0,8	LR30×35×16,5	IR30×35×16-XL	-
	-	-	-	0,8	LR30×35×20,5	IR30×35×20-XL	-
40	-	-	-	0,8	LR35×40×16,5	IR35×40×17-XL	-
	-	-	-	0,8	LR35×40×20,5	IR35×40×20-XL	-
45	-	-	-	0,8	LR40×45×20,5	IR40×45×20-XL	-
50	-	-	-	0,8	-	IR45×50×25-XL	-





Drawn cup needle roller bearings with open ends

Full complement
Unsealed

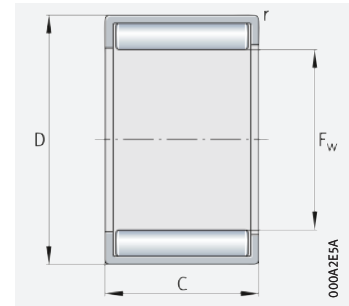

$F_w = 8 - 50 \text{ mm}$

Main dimensions			Basic load ratings		Fatigue limit load	Limiting speed	Speed rating	Mass	Designation ▶893 1.12 ▶894 1.13
F_w	D	C	dyn. C_r N	stat. C_{0r} N	C_{ur} N	n_G grease min^{-1}	$n_{\partial r}$ min^{-1}	m $\approx \text{g}$	
8	12	8	5 000	6 700	870	12 700	18 000	3	HN0808
12	16	10	8 000	13 400	1 850	8 900	11 900	5,3	HN1210
	18	12	10 200	15 200	1 950	8 600	12 000	10,5	HN1212
14	20	12	11 000	17 500	2 260	7 500	10 400	12	HN1412
15	21	16	15 400	27 500	3 600	7 100	9 600	14	HN1516
16	22	12	12 000	20 300	2 600	6 700	9 200	13	HN1612
18	24	16	17 000	32 500	4 250	6 000	8 000	20	HN1816
20	26	20	22 400	48 000	6 600	5 400	7 200	29,5	HN2020
25	32	20	28 000	59 000	7 900	4 350	5 800	39,6	HN2520
28	35	20	30 000	67 000	9 000	3 950	5 200	44	HN2820
	42	20	33 500	83 000	11 100	3 200	4 250	54	HN3520
40	47	20	36 000	95 000	12 700	2 800	3 750	60,5	HN4020
	52	20	38 500	108 000	14 500	2 500	3 400	66	HN4520
45	52	25	47 000	139 000	19 500	2 500	3 350	85	HN4525
	58	20	44 500	119 000	16 200	2 260	3 100	85,3	HN5020
50	58	25	54 000	152 000	21 700	2 260	3 050	107	HN5025

medias ▶ <https://www.schaeffler.de/std/1F19>



Dimensions		Suitable inner rings ▶ 992	
F_w	r min.	LR designation	IR designation
8	0,4	-	-
12	0,4	LR8×12×10,5	IR8×12×10,5-XL
	0,8	LR8×12×12,5	IR8×12×12,5-XL
14	0,8	-	IR10×14×13-XL
15	0,8	LR12×15×16,5	IR12×15×16-XL
16	0,8	-	IR12×16×13-XL
18	0,8	LR15×18×16,5	IR15×18×16-XL
20	0,8	LR17×20×20,5	IR17×20×20-XL
25	0,8	LR20×25×20,5	IR20×25×20-XL
28	0,8	LR22×28×20,5	IR20×28×20-XL
35	0,8	LR30×35×20,5	IR30×35×20-XL
40	0,8	LR35×40×20,5	IR32×40×20-XL
45	0,8	LR40×45×20,5	IR40×45×20-XL
	0,8	-	-
50	0,8	LR45×50×20,5	-
	0,8	LR45×50×25,5	IR45×50×25-XL



Needle roller bearings





Matrix for bearing preselection 912

1 Needle roller bearings, aligning needle roller bearings 914

1.1	Bearing design	914
1.2	Load carrying capacity	921
1.3	Compensation of angular misalignments	921
1.4	Lubrication	922
1.5	Sealing	922
1.6	Speeds	923
1.7	Noise	923
1.8	Temperature range	924
1.9	Cages	924
1.10	Internal clearance	924
1.11	Dimensions, tolerances	926
1.12	Suffixes	926
1.13	Structure of bearing designation	927
1.14	Dimensioning	928



1.15	Minimum load	928
1.16	Design of bearing arrangements	928
1.17	Mounting and dismounting	933
1.18	Legal notice regarding data freshness	934
1.19	Further information	934
	Product tables	936
	Needle roller bearings with ribs	936
	Needle roller bearings without ribs	956
	Aligning needle roller bearings	962
2	Combined needle roller bearings	964
2.1	Bearing design	964
2.2	Load carrying capacity	968
2.3	Compensation of angular misalignments	970
2.4	Lubrication	971
2.5	Sealing	972
2.6	Speeds	972
2.7	Noise	973
2.8	Temperature range	973
2.9	Cages	973
2.10	Internal clearance	973
2.11	Dimensions, tolerances	974
2.12	Suffixes	975
2.13	Structure of bearing designation	975
2.14	Dimensioning	976
2.15	Minimum load	977
2.16	Design of bearing arrangements	977
2.17	Mounting and dismounting	981
2.18	Legal notice regarding data freshness	982
2.19	Further information	982
	Product tables	984
	Needle roller/axial deep groove ball bearings	984
	Needle roller/axial cylindrical roller bearings	988
	Needle roller/angular contact ball bearings	990
3	Inner rings	992
3.1	Product design	992
3.2	Temperature range	994
3.3	Internal clearance	994
3.4	Tolerances	995
3.5	Suffixes	995
3.6	Structure of bearing designation	996
3.7	Design of bearing arrangements	996
3.8	Mounting and dismounting	997
3.9	Legal notice regarding data freshness	997
	Product tables	998
	Inner rings without lubrication hole	998
	Inner rings with lubrication hole	1004





Matrix for bearing preselection

The matrix gives an overview of the types and design features of needle roller bearings.

It can be used to make a preliminary assessment of whether a bearing is fundamentally suitable for the envisaged application.

The additional information provided in the product chapter (see column "detailed information") and in the Technical principles must, however, be observed in addition to this overview in selection of the bearing.

Design features and suitability			Machined needle roller bearings		
+++ extremely suitable ++ highly suitable + suitable (+) suitable with restrictions - not suitable/not applicable ✓ available			with ribs, with or without inner ring	without ribs, with or without inner ring	detailed information
					914
Load carrying capacity	radial		+++	+++	921 1.2
	axial, one direction		-	-	921 1.2
	axial, both directions		-	-	921 1.2
	moments		-	-	
Compensation of angular misalignments	static		-	-	921 1.3
	dynamic		-	-	921 1.3
Bearing design	cylindrical bore		✓	✓	914 1.1
	tapered bore		-	-	
	separable		✓ ¹⁾	✓	914 1.1
Lubrication	greased		✓ ³⁾	-	922 1.4
Sealing	open		✓	✓	922 1.5
	non-contact		-	-	922 1.5
	contact		✓	-	922 1.5
Operating temperature in °C		from to	-30 ⁶⁾ +120	-30 ⁶⁾ +120	924 1.8
Suitability for	high speeds		+++	+++	923 1.6
	high running accuracy		++	++	926 1.11 114
	low-noise running		+	+	923 1.7 27
	high rigidity		+++	+++	54
	reduced friction		++	++	56
	length compensation within bearing		+++	+++	914 1.1 25
	non-locating bearing arrangement		+++	+++	139
	locating bearing arrangement		-	-	139
X-life bearings			✓	✓	920
Inside diameter d and F _w in mm		from to	5 415	5 100	936
Product tables		from page	936	956	

1) Only the inner rings can be mounted separately
 2) Valid for axial component only in bearings without an end cap
 3) Sealed bearings only
 4) NKX...-Z is greased
 5) NKXR...-Z is greased
 6) Valid for bearings with sheet steel cage. With plastic cage: -20 °C to +120 °C
 7) For mounting in pairs
 8) Valid for NKIB only



Aligning needle roller bearings		Combined needle roller bearings				
with or without inner ring	detailed information	needle roller/axial deep groove ball bearings	needle roller/axial cylindrical roller bearings	needle roller/angular contact ball bearings	detailed information	
	914				964	
+++	➤ 921 1.2	+++	+++	+++	➤ 968 2.2	
-	➤ 921 1.2	++	+++	+	➤ 968 2.2	
-	➤ 921 1.2	-	-	++ ⁸⁾	➤ 968 2.2	
-		-	-	-		
++	➤ 921 1.3	-	-	-	➤ 970 2.3	
-	➤ 921 1.3	-	-	-	➤ 970 2.3	
✓	➤ 914 1.1	✓	✓	✓	➤ 964 2.1	
-		-	-	-		
✓ ¹⁾	➤ 914 1.1	✓ ²⁾	✓ ²⁾	✓ ¹⁾	➤ 964 2.1	
-	➤ 922 1.4	- ⁴⁾	- ⁵⁾	-	➤ 971 2.4	
✓	➤ 922 1.5	✓	✓	✓	➤ 972 2.5	
-	➤ 922 1.5	-	-	-	➤ 972 2.5	
-	➤ 922 1.5	-	-	-	➤ 972 2.5	
-20 +100	➤ 924 1.8	-30 +120	-30 +120	-30 +120	➤ 973 2.8	
++	➤ 923 1.6	+++	++	+++	➤ 972 2.6	
+	➤ 926 1.11 ➤ 114	++	++	++	➤ 974 2.11 ➤ 114	
(+)	➤ 923 1.7 ➤ 27	(+)	(+)	(+)	➤ 973 2.7 ➤ 27	
+	➤ 54	+++	+++	+++	➤ 54	
++	➤ 56	++	++	++	➤ 56	
+++	➤ 914 1.1 ➤ 25	(+)	(+)	(+)	➤ 25	
+++	➤ 139	-	-	-	➤ 139	
-	➤ 139	(+) ⁷⁾	(+) ⁷⁾	+	➤ 139	
✓	➤ 920	✓	✓	✓	➤ 968	X-life
12 45	➤ 962	7 70	15 50	12 70	➤ 984	
962		984	988	990		

1 Needle roller bearings, aligning needle roller bearings



The bearings:

- can support high to very high radial forces
- are used when the load carrying capacity or accuracy of drawn cup needle roller bearings with open ends is no longer sufficient and the high load capacity of cylindrical roller bearings is not yet required
- can only support radial loads and, as a result, are highly suitable for use as non-locating bearings (they permit axial displacement of the shaft relative to the housing in the bearing)
- permit high speeds in spite of line contact
- compensate misalignments between the shaft and housing (aligning needle roller bearings)
- require only a very small radial design envelope, particularly if the bearing arrangement is designed without an inner ring
- are available in numerous sizes and designs
- result in particularly compact, cost-effective and economical bearing arrangements.

For an overview of other product-specific features, see the Matrix for bearing preselection ►912.

1 Needle roller bearing in X-life quality: comparison of load carrying capacity with drawn cup needle roller bearing (open ends) of almost identical dimensions; angular adjustment facility of aligning needle roller bearings (permissible adjustment angle)

C_r = basic dynamic load rating

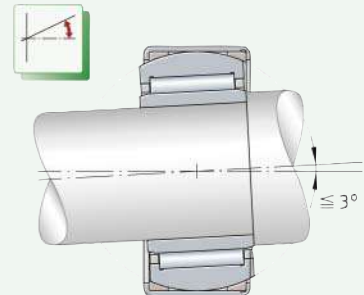
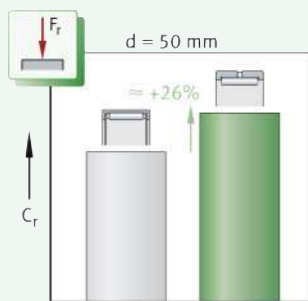

1.1 Bearing design

Design variants

Needle roller bearings are available as:

- needle roller bearings with ribs on the outer ring ►915|ⓐ 2 to ►917|ⓐ 5
- needle roller bearings without ribs on the outer ring ►918|ⓐ 6 and ►918|ⓐ 7
- aligning needle roller bearings ►919|ⓐ 8 and ►919|ⓐ 9
- combined needle roller bearings ►964.

Needle roller bearings are X-life bearings ►920.



In addition to the bearings described in this chapter, needle roller bearings are also available in other series, designs and sizes, as well as for specific applications, by agreement.

Needle roller bearings are non-locating bearings

Needle roller bearings

Needle roller bearings are rolling bearings with a low radial section height and high load carrying capacity, which are used as non-locating bearings and are part of the group of radial needle roller bearings. These bearings comprise machined outer rings, needle roller and cage assemblies and removable inner rings, i.e. they can be supplied with or without an inner ring in accordance with the application >915| 2 to >919| 8. In contrast to the outer cups of drawn cup needle roller bearings, which are produced by forming methods, the bearing rings are machined. Due to their non-locating bearing function, the bearings cannot guide the shaft axially in any direction.

The needle roller and cage assembly is guided by the ribs

Needle roller bearings with ribs on the outer ring

Needle roller bearings with ribs are ready-to-fit units. The outer ring and needle roller and cage assembly form a self-retaining unit. The needle roller and cage assembly is guided by the ribs on the outer ring. The outer ring has a lubrication groove and at least one lubrication hole. There is no relubrication facility in types NK with $F_w \leq 10$ mm and NKI with $d \leq 7$ mm. The bearings are predominantly of a single row design, type RNA69 is of a double row design above an enveloping circle diameter $F_w = 40$ mm and is therefore fitted with two needle roller and cage assemblies. The bearings are available:

- with or without an inner ring >915| 2 and >916| 4
- in a single or double row design >915| 2 and >916| 4
- as open or sealed versions >916| 3, >916| 4, >922| 1.5.

Available types

Needle roller bearings with ribs on the outer ring, without inner ring

Needle roller bearings with ribs on the outer ring and without an inner ring are available in the following types and dimension series:

- NK, NKS, RNA48, RNA49, RNA69 (single row) >915| 2
- RNA69..-ZW (double row) >915| 2
- RNA49..-RSR, RNA49..-2RSR (sealed on one or both sides) >916| 3 and >922| 1.5.

For bearing arrangements with particularly compact radial dimensions

Bearings without an inner ring are highly suitable for bearing arrangements with particularly compact radial dimensions, if the shaft raceway can be hardened and ground >928| 1.16. If no inner ring is used, the shaft can be designed to a greater thickness and thus with increased rigidity.

Length compensation (axial displacement facility)

Radial needle roller bearings are used as non-locating bearings, i.e. when the shaft must allow axial length compensation relative to the housing. For bearings without an inner ring, the axial displacement facility of the shaft is dependent on the width of the shaft raceway.



Needle roller bearings with ribs on the outer ring, without inner ring, open

F_r = radial load

- ① Single row needle roller bearing
- ② Double row needle roller bearing

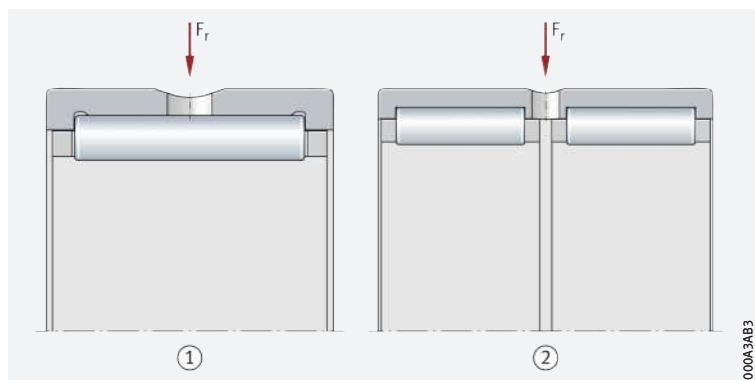

000A3AB3

3

Needle roller bearings with ribs on the outer ring, without inner ring, sealed on one or both sides

F_r = radial load

- ① Single row needle roller bearing, contact seal on one side
- ② Single row needle roller bearing, contact seal on both sides

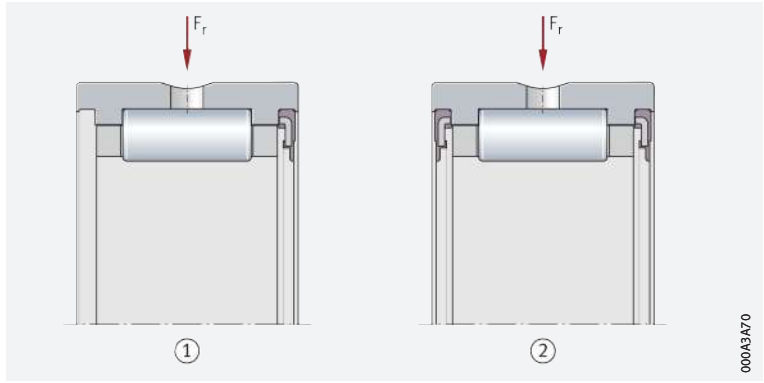

000A3A70

Needle roller bearings with ribs on the outer ring, with inner ring

Available types

Needle roller bearings with ribs on the outer ring and with an inner ring are available in the following types and dimension series:

- NKI, NKIS, NA48, NA49, NA69 (single row) ➤916| 4
- NA69...ZW (double row) ➤916| 4
- NA49...RSR, NA49...2RSR (sealed on one or both sides) ➤917| 5 and ➤922| 1.5.

Bearings with an inner ring are used if the shaft cannot be configured as a rolling bearing raceway. The bearings are of a single row design, NA69 is of a double row design from $d \geq 32$ mm.

Axial displacement of the inner ring

For bearings with an inner ring, the axial displacement of the shaft relative to the housing occurs during rotational motion, without constraint in the bearing, between the needle rollers and the inner ring raceway without ribs. The maximum axial displacement s is given in the product tables. Where larger displacements occur, the standard ring can be replaced by a wider inner ring IR. Inner rings ➤992.

Replacement of inner rings



In the case of the standard bearings, the inner rings are matched to the enveloping circle tolerance F6 and can be interchanged with each other (mixed use) within the same accuracy class.

4

Needle roller bearings with ribs on the outer ring, with inner ring, open

F_r = radial load

- ① Single row needle roller bearing
- ② Double row needle roller bearing

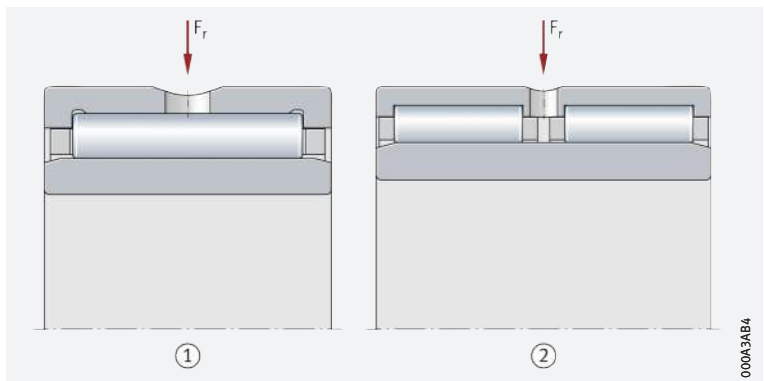

000A3AB4



5
 Needle roller bearings
 with ribs on the outer ring,
 with inner ring,
 sealed on one or both sides

F_r = radial load

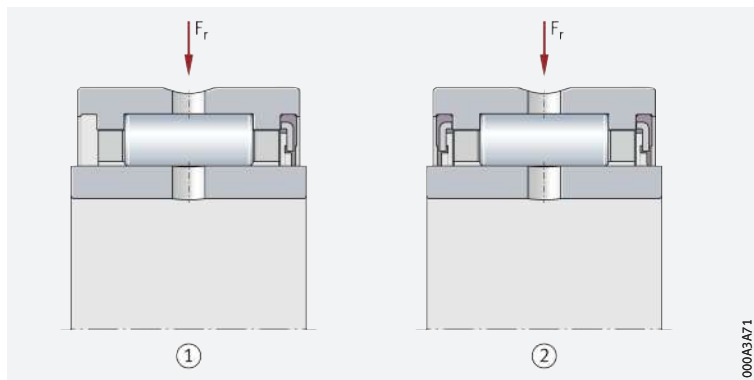
- ① Single row needle roller bearing,
contact seal on one side
- ② Single row needle roller bearing,
contact seal on both sides



Needle roller bearings without ribs on the outer ring

 The bearing components
 can be mounted
 independently of each other

Needle roller bearings without ribs on the outer ring are ready-to-fit units. The bearings are not self-retaining. This means that the outer ring, needle roller and cage assembly and inner ring can be fitted independently of each other. The needle roller and cage assembly can be mounted in different ways: it can be fitted together with the shaft, the outer ring or the inner ring, or it can be subsequently inserted between the outer ring and shaft or inner ring. The needle roller and cage assembly and outer ring must not, however, be interchanged with identical components from other bearings during mounting, but should always be fitted as supplied. The majority of the bearings are of a single row design. Double row bearings comprise two single row needle roller and cage assemblies arranged adjacent to each other. They have a lubrication groove in the circumference of the outer ring, at least one lubrication hole in the outer ring and the suffix ZW-ASR1 ▶926|1.12. Bearings are also available with a lubrication hole in the inner ring; these have the suffix IS1 ▶926|1.12.

Needle roller bearings without ribs on the outer ring are available:

- with and without an inner ring ▶918|6 and ▶918|7
- in a single or double row design ▶916|3 and ▶917|5.

Needle roller bearings without ribs on the outer ring, without inner ring

 Available types

Needle roller bearings without ribs on the outer ring and without an inner ring are available in the following types:

- RNAO (single row) ▶918|6
- RNAO..-ZW-ASR1 (double row) ▶918|6.

 For bearing arrangements
 with particularly compact
 radial dimensions

Bearings without an inner ring are highly suitable for bearing arrangements with particularly compact radial dimensions, if the shaft raceway can be hardened and ground ▶928|1.16. If no inner ring is used, the shaft can be designed to a greater thickness and thus with increased rigidity. If the shaft raceway is produced to the appropriate dimensional and geometrical accuracy, bearing arrangements with increased running accuracy can be achieved.

 Length compensation
 (axial displacement facility)

Radial needle roller bearings are used as non-locating bearings, i.e. when the shaft must allow axial length compensation relative to the housing. For bearings without an inner ring, the axial displacement facility of the shaft is dependent on the width of the shaft raceway.



Needle roller bearings without ribs on the outer ring, without inner ring, open

F_r = radial load

- ① Single row needle roller bearing
- ② Double row needle roller bearing

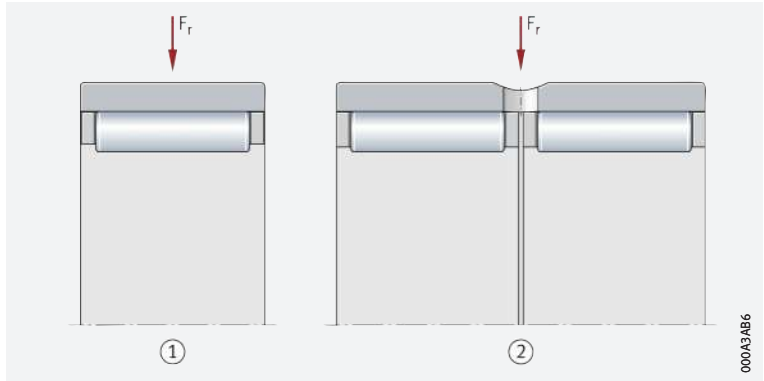

000A3AB6

Needle roller bearings without ribs on the outer ring, with inner ring

Available types

Needle roller bearings without ribs on the outer ring and with an inner ring are available in the following types:

- NAO (single row) >918 | ⑦
- NAO..-ZW-ASR1 (double row) >918 | ⑦.

Bearings with an inner ring are used if the shaft cannot be configured as a rolling bearing raceway.

Axial displacement of the inner ring

For bearings with an inner ring, the axial displacement of the shaft relative to the housing occurs during rotational motion, without constraint in the bearing, between the needle rollers and the inner ring raceway without ribs. The maximum axial displacement s is given in the product tables >960 | ⑧. Where larger displacements occur, the standard ring can be replaced by a wider inner ring IR. Inner rings >992.

Replacement of inner rings



The outer ring and the needle roller and cage assembly are matched to each other and must not be interchanged during mounting with components from other bearings of the same size. In the case of the standard bearings, the inner rings are matched to the enveloping circle tolerance F6 and can be interchanged with each other (mixed use) within the same accuracy class.



Needle roller bearings without ribs on the outer ring, with inner ring, open

F_r = radial load

- ① Single row needle roller bearing
- ② Double row needle roller bearing

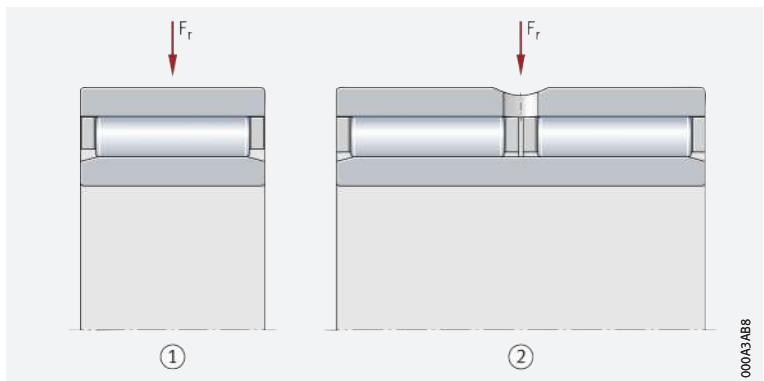

000A3AB8

Aligning needle roller bearings

Suitable for the compensation of angular misalignments

Aligning needle roller bearings comprise drawn outer cups, plastic support rings with a concave inner profile, outer rings with a spherical outside surface, needle roller and cage assemblies and removable inner rings >919 | ⑧. As a result of their design, these bearings can compensate misalignments, since the outer ring, with its spherical outside surface, is able to move in the concave plastic support ring >921 | 1.3. Due to their non-locating bearing function, the bearings cannot guide the shaft axially in any direction.

Aligning needle roller bearings without inner ring

- Available types
- For bearing arrangements with particularly compact radial dimensions

Aligning needle roller bearings are available in type RPNA ▶919| 8. Bearings without an inner ring are highly suitable for bearing arrangements with low section height and particularly compact dimensions, if the shaft raceway can be hardened and ground ▶928| 1.16. If no inner ring is used, the shaft can be designed to a greater thickness and thus with increased rigidity.



Aligning needle roller bearing without inner ring

F_r = radial load

- 1 Drawn outer cup
- 2 Plastic support rings with concave inner profile
- 3 Outer ring with spherical outside surface
- 4 Needle roller and cage assembly

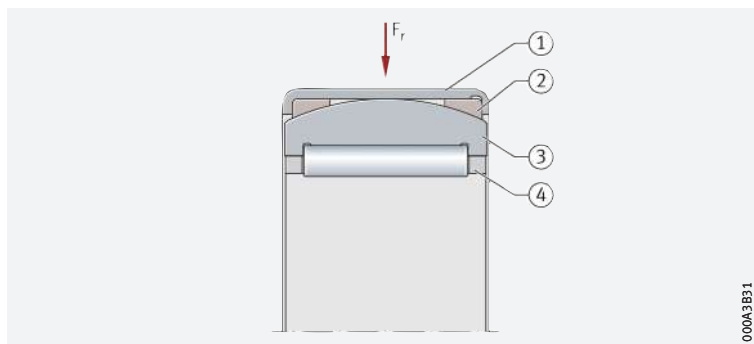

Aligning needle roller bearings with inner ring

- Available types
- Axial displacement of the inner ring

Aligning needle roller bearings are available in type PNA ▶919| 9. Bearings with an inner ring are used if the shaft cannot be configured as a rolling bearing raceway. For bearings with an inner ring, the axial displacement of the shaft relative to the housing occurs during rotational motion, without constraint in the bearing, between the needle rollers and the inner ring raceway without ribs. The maximum axial displacement s is given in the product tables ▶962| 9. Where larger displacements occur, the standard ring can be replaced by a wider inner ring of series IR. Inner rings ▶992.

Replacement of inner rings



In the case of the standard bearings, the inner rings are matched to the enveloping circle tolerance F6 and can be interchanged with each other (mixed use) within the same accuracy class.



Aligning needle roller bearing with inner ring

F_r = radial load

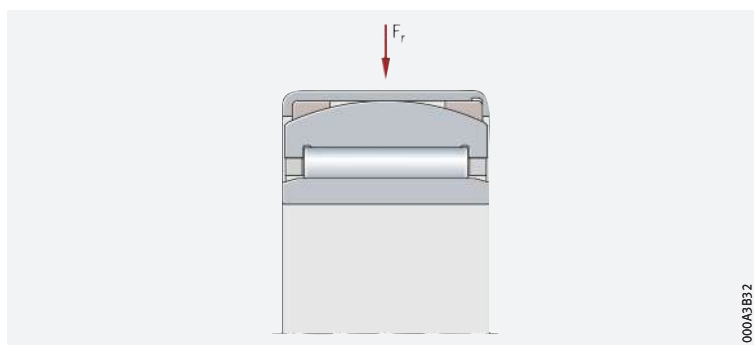

X-life

X-life premium quality

The radial needle roller bearings described here are X-life bearings. These bearings are characterised by a very high load carrying capacity and long rating life. This is achieved, for example, through the modified internal construction and optimised contact geometry between the needle rollers and raceways, as well as through the higher quality of the steel and rolling elements, higher surface quality and appropriate heat treatment and/or coating.

Advantages

The technical enhancements offer a range of advantages, such as:

- a more favourable load distribution in the bearing and thus a higher dynamic load carrying capacity of the bearings
- quieter running
- running with reduced friction and greater energy efficiency
- lower heat generation in the bearing
- higher possible speeds
- lower lubricant consumption and, consequently, longer maintenance intervals
- a measurably longer operating life
- high operational security
- compact, environmentally-friendly bearing arrangements.

🔗 *Increased customer benefits due to X-life*

🔗 *Lower operating costs, higher machine availability*

🔗 *Suffix XL*

In conclusion, these advantages improve the overall cost-efficiency of the bearing position significantly and thus bring about a sustainable increase in the efficiency of the machine and equipment.

X-life radial needle roller bearings include the suffix XL in the designation ► 920 | 📐 10, ► 927 | 📐 14 and ► 936 | 📐.

📐 10

Calculated rating life and rating life verified in tests – comparison between X-life needle roller bearing and bearings without X-life quality

L_{nmr} = adjusted reference rating life

- ① Bearing without X-life quality
- ② Calculated rating life
- ③ Rating life verified in tests

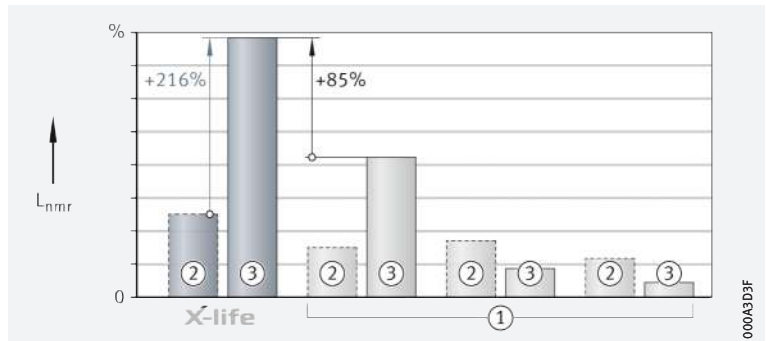

Areas of application

🔗 *Wide application range*

Due to their special technical features, X-life needle roller bearings are highly suitable for bearing arrangements in:

- printing machinery
- the food and packaging industry
- compressors
- fluid and hydraulic pumps
- automotive chassis and gearboxes
- gearboxes for industrial, rail and wind turbine applications
- agricultural vehicles and equipment.



X-life indicates a high product performance density and thus a particularly significant benefit to the customer. Further information on X-life ► 10.

1.2 Load carrying capacity

☞ *The bearings are pure radial bearings*

Radial needle roller bearings support very high radial forces due to the presence of line contact, but may only be subjected to purely radial load. If the bearing position is also required to support axial forces, the needle roller bearings can, for example, be combined with axial needle roller bearings AXW ►921|☞ 11. An extensive range of combined needle roller bearings is also available for combined loads ►964.



If the surface of the shaft raceway is produced to DIN 617, the basic load ratings C_r in the product tables must be reduced by 15%.



11
Radial needle roller bearing
combined with
axial needle roller bearing

F_r = radial load

F_a = axial load

① Needle roller bearing NK

② Axial needle roller bearing AXW

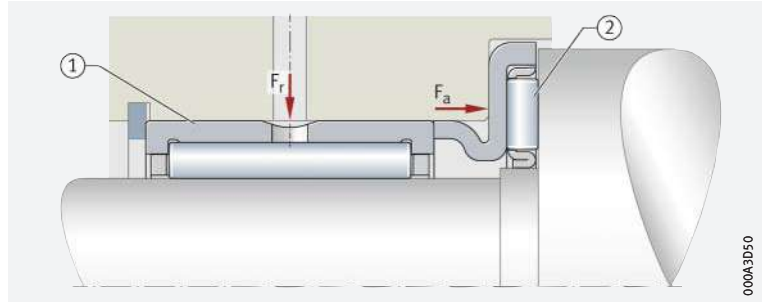

1.3 Compensation of angular misalignments

☞ *The bearings are not suitable for the compensation of shaft misalignments relative to the housing.*

Needle roller bearings with or without ribs on the outer ring are not suitable for the compensation of angular misalignments. The extent to which a misalignment of the shaft can be tolerated relative to the housing bore is dependent on factors such as the design of the bearing arrangement, the size of the bearing, the operating clearance and the load. As a result, no guide value can be specified here for a possible misalignment. If angular misalignments occur, aligning needle roller bearings can be used ►921|☞ 12.



In all cases, misalignments cause increased running noise, place increased strain on the cages and have a harmful influence on the operating life of the bearings.

Aligning needle roller bearings

☞ *Aligning needle roller bearings can compensate static misalignment*

Due to the spherical outer ring and the concave support ring, aligning bearings can compensate static misalignments between the shaft and housing of up to 3° ►921|☞ 12 and ►914| 1.1. The bearings must not, however, be used to support swivel or tumbling motion. During adjustment motion between the outer cup and the ring, a breakaway torque occurs. In order that adjustment motion can take place, the tolerances for the housing bore must be observed ►930|☞ 5.



12
Compensation of misalignments

① Spherical outer ring

② Concave support ring

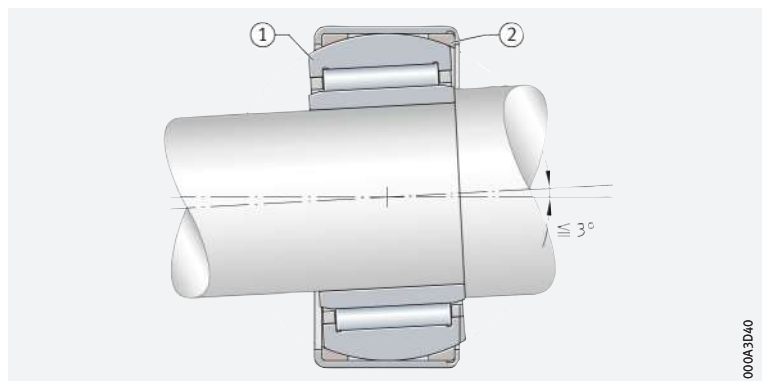

1.4 Lubrication

Greased bearings

Needle roller bearings with or without ribs on the outer ring

The sealed bearings are greased with a high quality lithium complex soap grease to GA08. Arcanol LOAD150 is suitable for relubrication.

For this purpose, the outer ring has a lubrication groove and a lubrication hole [▶ 914 | 1.1](#).



Do not wash greased bearings out prior to mounting. If mounting is carried out using thermal tools, the bearings should not be heated to a temperature in excess of +80 °C, taking account of the grease filling and seal material. If higher heating temperatures are required, it must be ensured that the permissible upper temperature limits for grease and seals are not exceeded. Schaeffler recommends the use of induction heating devices for heating purposes [▶ 231](#).

Ungreased bearings

Open bearings are not greased. They must be lubricated with oil or grease.

Compatibility with plastic cages

When using bearings with plastic cages, compatibility between the lubricant and the cage material must be ensured if synthetic oils, lubricating greases with a synthetic oil base or lubricants containing a high proportion of EP additives are used.

Observe oil change intervals

Aged oil and additives in the oil can impair the operating life of plastics at high temperatures. As a result, stipulated oil change intervals must be strictly observed.



If there is any uncertainty regarding the suitability of the selected lubricant for the application, please consult Schaeffler or the lubricant manufacturer.

1.5 Sealing

The bearings are open or sealed

Needle roller bearings are available in an unsealed design in accordance with DIN 617:2008 and ISO 3245:2015 and a sealed design in accordance with DIN 617:2008.

Integrated seals are particularly space-saving

Sealed bearings

Under normal operating conditions, contact seals give protection against contamination, spray water and the loss of lubricant. The integration of such seals into the bearing provides a compact, reliable, proven and economical sealing solution [▶ 916 | 3](#) and [▶ 917 | 5](#).

The sealing material used is the oil-resistant and wear-resistant elastomer material NBR. The seal lips are in contact with a defined contact pressure against the sliding surface.

Provide seals in the adjacent construction

Unsealed bearings

In the case of unsealed bearings, sealing of the bearing position must be carried out in the adjacent construction. This must reliably prevent:

- moisture and contaminants from entering the bearing
- the egress of lubricant from the bearing.



Sealing rings must not be used as running surfaces for the cage, as these will be damaged as a result and no longer able to fulfil their sealing function.

Effective sealing elements for use in sealing open bearings

Sealing of the bearing position with a sealing ring G

Bearing positions with open needle roller bearings can be sealed cost-effectively with sealing rings G. The sealing rings are designed as contact seals and are arranged in front of the bearing ▶923|📄13.

They are suitable for circumferential velocities at the running surface of up to 10 m/s and protect the bearing position reliably against contamination, spray water and the excessive loss of lubricant. The sealing rings are matched to the low radial dimensions of needle roller bearings. They are very easy to fit, since they are simply pressed into the housing bore.

📄13

Sealing of the bearing position with a sealing ring G

- ① Needle roller bearing with ribs on the outer ring, open
- ② Sealing ring G

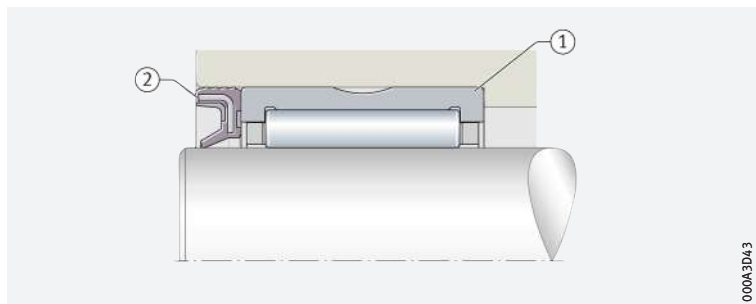

000A3D43

1.6 Speeds

Limiting speeds and reference speeds in the product tables

The product tables generally give two speeds for the bearings ▶936|📄:

- the kinematic limiting speed n_G
- the thermal speed rating $n_{\vartheta r}$.

Limiting speeds



The limiting speed n_G is the kinematically permissible speed of the bearing. Even under favourable mounting and operating conditions, this value should not be exceeded without prior consultation with Schaeffler ▶64.

The values given in the product tables are valid for oil lubrication in the case of bearings without seals and for grease lubrication where bearings are supplied greased and with seals.

Values for grease lubrication

For grease lubrication, 60% of the value stated in the product tables is permissible in the case of aligning needle roller bearings.

Reference speeds

$n_{\vartheta r}$ is used to calculate n_{ϑ}

The thermal speed rating $n_{\vartheta r}$ is not an application-oriented speed limit, but is a calculated ancillary value for determining the thermally safe operating speed n_{ϑ} ▶64.

Bearings with contact seals

For bearings with contact seals, no reference speeds are defined in accordance with DIN ISO 15312:2004. As a result, only the limiting speed n_G is given in the product tables for these bearings.

1.7 Noise

Schaeffler Noise Index

The Schaeffler Noise Index (SGI) is not yet available for this bearing type ▶69. The data for these bearing series will be introduced and updated in stages.

Further information:

- **medias** ▶ <https://medias.schaeffler.com>.



1.8 Temperature range

Limiting values

- The operating temperature of the bearings is limited by:
- the dimensional stability of the bearing rings and rolling elements
 - the cage
 - the lubricant
 - the seals.

Possible operating temperatures of needle roller bearings with ribs
 ➤ 924 | 1.

1
Permissible temperature ranges

Operating temperature	Needle roller bearings with or without ribs, aligning needle roller bearings		
	open bearings	sealed bearings, aligning needle roller bearings	with plastic cage
	-30 °C to +120 °C	-20 °C to +100 °C limited by the lubricant, seal material and the plastic support ring	-20 °C to +120 °C



In the event of anticipated temperatures which lie outside the stated values, please contact Schaeffler.

1.9 Cages

Solid cages made from polyamide PA66 and sheet steel are used as standard

The standard cages are made from sheet steel or plastic (polyamide PA66). Bearings with a plastic cage have the suffix TV. Aligning needle roller bearings are fitted with sheet steel cages.

1.10 Internal clearance

The standard is CN

Radial internal clearance

Needle roller bearings with an inner ring are manufactured as standard with radial internal clearance CN (normal) ➤ 924 | 2. CN is not stated in the designation.



For bearings with ribs on the outer ring, certain sizes are also available by agreement with the larger internal clearance C3.



The values for radial internal clearance in bearings with an inner ring correspond to DIN 620-4:2004 (ISO 5753-1:2009) ➤ 924 | 2. They are valid for bearings which are free from load and measurement forces (without elastic deformation).

Bearings with inner ring

2
Radial internal clearance of needle roller bearings with inner ring

Nominal bore diameter		Radial internal clearance			
		CN (Group N)		C3 (Group 3)	
d		μm		μm	
mm		min.	max.	min.	max.
over	incl.				
-	24	20	45	35	60
24	30	20	45	35	60
30	40	25	50	45	70
40	50	30	60	50	80
50	65	40	70	60	90
65	80	40	75	65	100
80	100	50	85	75	110
100	120	50	90	85	125
120	140	60	105	100	145

continued ▼

 **2**
Radial internal clearance
of needle roller bearings
with inner ring

Nominal bore diameter d mm		Radial internal clearance			
		CN (Group N)		C3 (Group 3)	
		μm		μm	
over	incl.	min.	max.	min.	max.
140	160	70	120	115	165
160	180	75	125	120	170
180	200	90	145	140	195
200	225	105	165	160	220
225	250	110	175	170	235
250	280	125	195	190	260
280	315	130	205	200	275
315	355	145	225	225	305
355	400	190	280	280	370
400	450	210	310	310	410
450	500	220	330	330	440

continued ▲

Enveloping circle diameter F_w for bearings without an inner ring

 In the case of bearings
without an inner ring,
the enveloping circle
diameter is used

In the case of bearings without inner ring, the dimension for the enveloping circle diameter F_w is used instead of the radial internal clearance. The enveloping circle is the inner inscribed circle of the needle rollers in clearance-free contact with the outer raceway. For bearings before fitting, the enveloping circle F_w is in the tolerance class F6. Deviations \blacktriangleright 925 |  3.

 **3**
Deviations for the enveloping
circle diameter

Enveloping circle diameter F_w mm		Tolerance class F6		Tolerance class F8	
		Tolerance for enveloping circle diameter F_w			
		upper deviation	lower deviation	upper deviation	lower deviation
over	incl.	μm	μm	μm	μm
3	6	+18	+10	+28	+10
6	10	+22	+13	+35	+13
10	18	+27	+16	+43	+16
18	30	+33	+20	+53	+20
30	50	+41	+25	+64	+25
50	80	+49	+30	+76	+30
80	120	+58	+36	+90	+36
120	180	+68	+43	+106	+43
180	250	+79	+50	+122	+50
250	315	+88	+56	+137	+56
315	400	+98	+62	+151	+62
400	500	+108	+68	+165	+68

Bearings without ribs on the outer ring



If the enveloping circle is to be in tolerance class F6, the outer ring/needle roller cage assembly as a matched pair (as delivered) must not be interchanged with parts from other matched pairs during mounting of the bearings.



1.11 Dimensions, tolerances

Dimension standards



The main dimensions of needle roller bearings correspond to ISO 15:2017. The main dimensions of types RNA48, NA48, RNA49, NA49, RNA69, NA69 correspond to DIN 617:2008 and ISO 1206:2001.

Nominal dimensions of needle roller bearings with ribs >936|

Chamfer dimensions



The limiting dimensions for chamfer dimensions correspond to DIN 620-6:2004. The maximum chamfer dimensions for the inner rings to DIN 620-6:2004 must be taken into consideration. Overview and limiting values >135|7.11. Nominal value of chamfer dimension >936|

Tolerances



The tolerances for the dimensional and running accuracy of needle roller bearings correspond to ISO 492:2014. This excludes the types RNA48, NA48, RNA49, NA49, RNA69, NA69 and aligning needle roller bearings; the dimensional and running tolerances of these bearings correspond to ISO 1206:2001. Needle roller bearings with ribs are available by agreement with increased dimensional, geometrical and running accuracy (suffix P5). This excludes the outside diameter and the width of the outer cup in aligning needle roller bearings. The width has a tolerance of ±0,5 mm.

1.12 Suffixes

For a description of the suffixes used in this chapter >926| 4 and **medias** interchange ><https://www.schaeffler.de/std/1D52>.

4
Suffixes and
corresponding descriptions

Suffix	Description of suffix	
ASR1	Lubrication hole and lubrication groove in the outer ring, dependent on the size	Standard
C3	Radial internal clearance C3 (larger than normal)	Special design, available by agreement
D	Bearing with improved steel cage for downsizing option	Standard
IS1	Lubrication hole in the inner ring, dependent on the size	
P5	Bearing with high dimensional, geometrical and running accuracy	Special design, available by agreement
RSR	Contact seal on one side (lip seal)	Standard
TV	Bearing with cage made from glass fibre reinforced polyamide PA66	
TW	Bearing with cage made from glass fibre reinforced polyamide PA66 and two short needle rollers per cage pocket	Available by agreement
XL	X-life bearing	Standard
ZW	Double row design, dependent on the size	
2RSR	Contact seal on both sides (lip seal)	

1.13 Structure of bearing designation

Examples of composition of bearing designation

The designation of bearings follows a set model. Examples ▶ 927 | 14 to ▶ 927 | 17. The composition of designations is subject in part to DIN 623-1 ▶ 102 | 10.

14

Single row needle roller bearing with ribs on the outer ring, without inner ring, open: designation structure

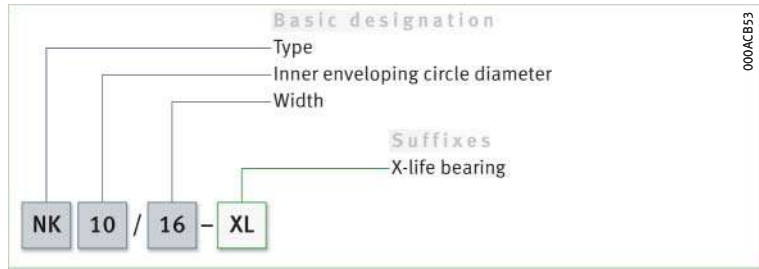

15

Single row needle roller bearing with ribs on the outer ring, without inner ring, sealed on both sides: designation structure

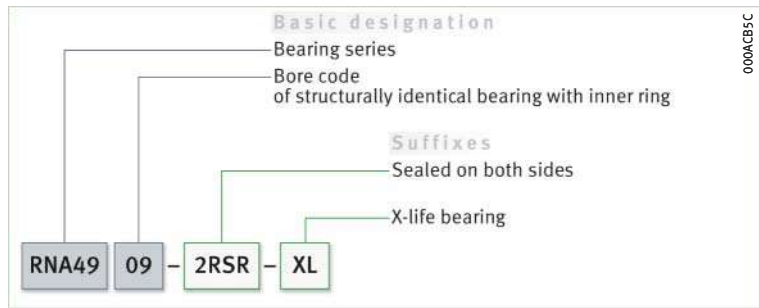

16

Double row needle roller bearing without ribs on the outer ring, without inner ring, open: designation structure

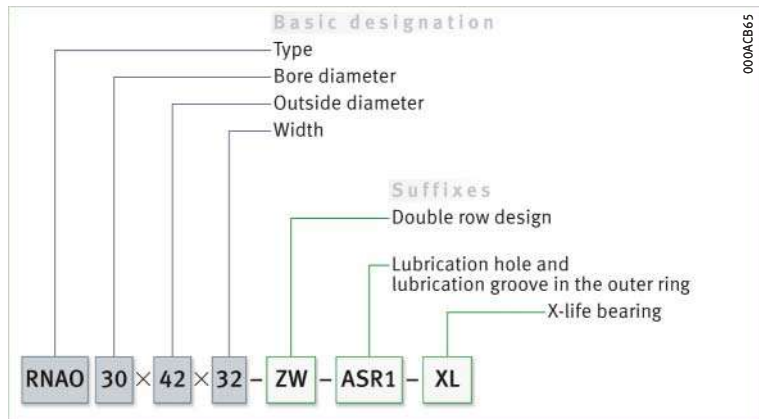

17

Aligning needle roller bearing with inner ring: designation structure

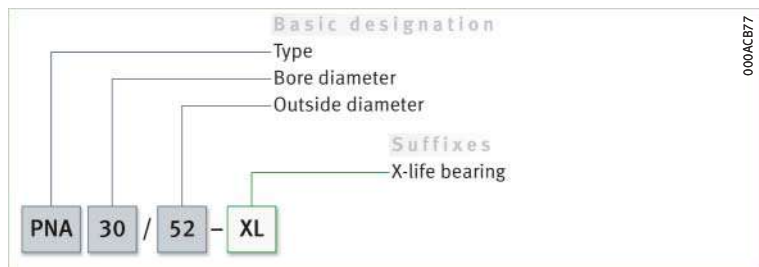

1.14 Dimensioning

$P = F_r$ under purely radial load of constant magnitude and direction

Equivalent dynamic bearing load

The basic rating life equation $L = (C_r/P)^P$ used in the dimensioning of bearings under dynamic load assumes a load of constant magnitude and direction. In radial bearings, this is a purely radial load F_r . If this condition is met, the bearing load F_r is used in the rating life equation for P ($P = F_r$) **► 928** | **f1**.



Needle roller bearings and aligning needle roller bearings are non-locating bearings and may only be subjected to radial load.

f1
Equivalent dynamic load

$$P = F_r$$

Legend

P	N	Equivalent dynamic bearing load
F_r	N	Radial load.

Equivalent static bearing load

For needle roller bearings subjected to static load **► 928** | **f2**.

f2
Equivalent static load

$$P_0 = F_{Or}$$

Legend

P_0	N	Equivalent static bearing load
F_{Or}	N	Largest radial load present (maximum load).

$S_0 = C_0/P_0$

Static load safety factor

In addition to the basic rating life $L (L_{10h})$, it is also always necessary to check the static load safety factor S_0 **► 928** | **f3**.

f3
Static load safety factor

$$S_0 = \frac{C_0}{P_0}$$

Legend

S_0	-	Static load safety factor
C_0	N	Basic static load rating
P_0	N	Equivalent static bearing load.

1.15 Minimum load

In order to prevent damage due to slippage, a minimum radial load of $P > C_{0r}/60$ is required

In order that no slippage occurs between the contact partners, the needle roller bearings must be constantly subjected to a sufficiently high load. Based on experience, a minimum radial load of the order of $P > C_{0r}/60$ is thus necessary. In most cases, however, the radial load is already higher than the requisite minimum load due to the weight of the supported parts and the external forces.



If the minimum radial load is lower than indicated above, please consult Schaeffler.

1.16 Design of bearing arrangements

Support bearing rings over their entire circumference and width

In order to allow full utilisation of the load carrying capacity of the bearings and achieve the requisite rating life, the bearing rings must be rigidly and uniformly supported by means of contact surfaces over their entire circumference and over the entire width of the raceway. Support can be provided by means of a cylindrical seating surface. The seating and contact surfaces should not be interrupted by grooves, holes or other recesses. The accuracy of mating parts must meet specific requirements **► 930** | **6** and **► 931** | **7**.

☞ *For secure radial location, tight fits are necessary*

Radial location

Needle roller bearings with an inner ring are radially located by means of fits on the shaft and in the housing. In addition to supporting the rings adequately, the bearings must also be securely located in a radial direction, to prevent creep of the bearing rings on the mating parts under load. This is generally achieved by means of tight fits between the bearing rings and the mating parts. If the rings are not secured adequately or correctly, this can cause severe damage to the bearings and adjacent machine parts. Influencing factors, such as the conditions of rotation, magnitude of the load, internal clearance, temperature conditions, design of the mating parts, mounting and dismounting options etc., must be taken into consideration in the selection of fits.



If shock type loads occur, tight fits (transition fit or interference fit) are required to prevent the rings from coming loose at any point. Clearance, transition or interference fits ▶ 150 | 6 and ▶ 158 | 7.



The following information provided in Technical principles must be taken into consideration in the design of bearing arrangements:

- conditions of rotation ▶ 145
- tolerance classes for cylindrical shaft seats (radial bearings) ▶ 147 | 2
- shaft fits ▶ 150 | 6
- tolerance classes for bearing seats in housings (radial bearings) ▶ 148 | 4
- housing fits ▶ 158 | 7.

Axial location – location methods

☞ *The bearings must also be securely located in an axial direction*

As a tight fit alone is not normally sufficient to also locate the bearing rings securely on the shaft and in the housing bore in an axial direction, this must usually be achieved by means of an additional axial location or retention method. The axial location of the bearing rings must be matched to the type of bearing arrangement. Shaft and housing shoulders, housing covers, nuts, spacer rings and retaining rings etc., are fundamentally suitable ▶ 929 | 18 and ▶ 929 | 19.



18
Axial location of the bearing rings in bearings with ribs on the outer ring

① Retaining ring

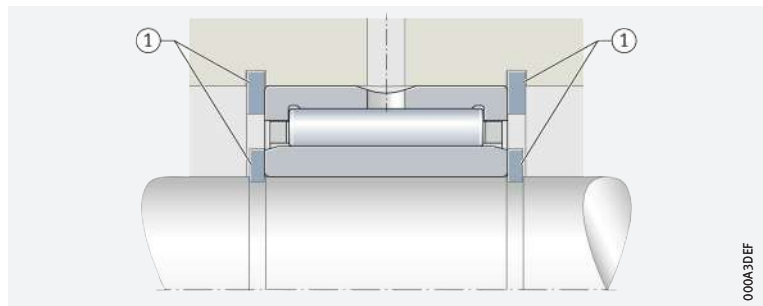

19
Axial location of the bearing rings in bearings without ribs on the outer ring

① Retaining ring

② Axial washer

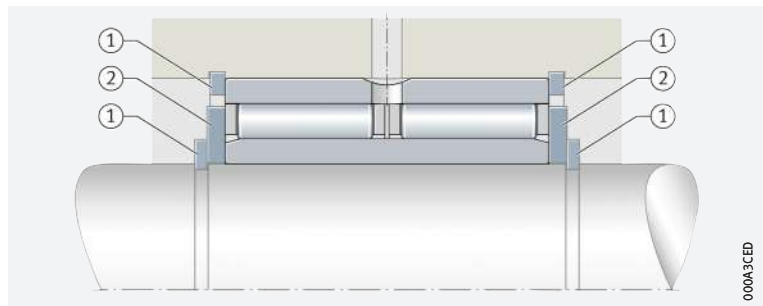

Axial guidance of the needle roller and cage assemblies in bearings without ribs on the outer ring



The needle roller and cage assemblies must be axially guided on lateral, burr-free running surfaces. The running surfaces for the cage must be precision machined (Ra 2) and resistant to wear. The product tables give the maximum value of the radius r_a , the diameters of the abutment shoulders d_a, D_a and the dimension d_b, D_b for axial guidance of the needle roller and cage assembly. Mounting dimensions ➤956 | 7.

Tolerances of the housing bore for aligning needle roller bearings



5
Tolerance classes and surface design for housings, as a function of the material – for aligning needle roller bearings

Housing material	Bore tolerance to ISO 286-2	Roundness tolerance	Parallelism tolerance	Recommended mean roughness value Ramax (Rzmax) µm
		max.	max.	
Steel or cast iron	N6 Ⓜ	IT5/2	IT5/2	0,8 (4)
Light metal	R6 Ⓜ			

Dimensional, geometrical and running accuracy of cylindrical bearing seats

☞ A minimum of IT6 should be provided for the shaft seat and a minimum of IT7 for the housing seat

The accuracy of the cylindrical bearing seat on the shaft and in the housing should correspond to the accuracy of the bearing used. For needle roller bearings with ribs with the tolerance class Normal, the shaft seat should correspond to a minimum of standard tolerance grade IT6 and the housing seat to a minimum of IT7. Guide values for the geometrical and positional tolerances of the bearing seating surfaces ➤930 | 6, tolerances t_1 to t_3 in accordance with ➤168 | 1.1. Numerical values for IT grades ➤931 | 7.



6
Guide values for the geometrical and positional tolerances of bearing seating surfaces

Bearing tolerance class		Bearing seating surface	Standard tolerance grades to ISO 286-1 (IT grades)			
to ISO 492	to DIN 620		Diameter tolerance	Roundness tolerance	Parallelism tolerance	Total axial runout tolerance of abutment shoulder
			t_1	t_2	t_3	
Normal	PN (P0)	Shaft	IT6 (IT5)	Circumferential load IT4/2	Circumferential load IT4/2	IT4
				Point load IT5/2	Point load IT5/2	
		Housing	IT7 (IT6)	Circumferential load IT5/2	Circumferential load IT5/2	IT5
				Point load IT6/2	Point load IT6/2	
–	P5	Shaft	IT5	Circumferential load IT2/2	Circumferential load IT2/2	IT2
				Point load IT3/2	Point load IT3/2	
		Housing	IT6	Circumferential load IT3/2	Circumferential load IT3/2	IT3
				Point load IT4/2	Point load IT4/2	

 **7**
 Numerical values
 for ISO standard tolerances
 (IT grades) to ISO 286-1:2010

IT grade	Nominal dimension in mm												
	over	3	6	10	18	30	50	80	120	180	250	315	400
	incl.	6	10	18	30	50	80	120	180	250	315	400	500
Values in μm													
IT2	1,5	1,5	2	2,5	2,5	3	4	5	7	8	9	10	
IT3	2,5	2,5	3	4	4	5	6	8	10	12	13	15	
IT4	4	4	5	6	7	8	10	12	14	16	18	20	
IT5	5	6	8	9	11	13	15	18	20	23	25	27	
IT6	8	9	11	13	16	19	22	25	29	32	36	40	
IT7	12	15	18	21	25	30	35	40	46	52	57	63	

Roughness of cylindrical bearing seating surfaces

 *Ra must not be too high*

The roughness of the bearing seats must be matched to the tolerance class of the bearings. The mean roughness value R_a must not be too high, in order to maintain the interference loss within limits. The shafts must be ground, while the bores must be precision turned. Guide values as a function of the IT grade of bearing seating surfaces  8.

 **8**
 Roughness values
 for cylindrical bearing seating
 surfaces – guide values

Nominal diameter of the bearing seat d (D) mm		Recommended mean roughness value for ground bearing seats R_{amax} μm			
		Diameter tolerance (IT grade)			
over	incl.	IT7	IT6	IT5	IT4
–	80	1,6	0,8	0,4	0,2
80	500	1,6	1,6	0,8	0,4

Mounting dimensions

 *The contact surfaces for the rings must be of sufficient height*

The mounting dimensions of the shaft and housing shoulders, and spacer rings etc., must ensure that the contact surfaces for the bearing rings are of sufficient height. However, they must also reliably prevent rotating parts of the bearing from grazing stationary parts. The abutment shoulders (shaft, housing) should be perpendicular to the bearing axis.





The transition from the bearing seat to the abutment shoulder must be designed with rounding to DIN 5418 or an undercut to DIN 509.

 *Chamfer dimensions*

The chamfer dimensions r are given in the product tables. These dimensions are limiting dimensions (minimum dimensions); the actual values should not be lower than specified. The overlap between the snap rings and the end faces of the bearing rings must be sufficiently large.

Raceway for bearings without an inner ring (direct bearing arrangement)

 *The raceway must be suitable as a rolling bearing raceway*

In the case of needle roller bearings without an inner ring, the rolling element raceway on the shaft must be hardened and ground. Tolerances and surface designs are shown in  9. The surface hardness of the raceway must be 670 HV to 840 HV, the hardening depth CHD or SHD must be sufficiently large.



The values in the tables are valid for housing tolerances up to K7 . For tighter bores, the operating clearance should be checked by either calculation or measurement.

9
Tolerance classes and surface design of raceways for needle roller bearings without an inner ring

Shaft diameter		Shaft tolerance ¹⁾			Design of raceway		
					Roundness tolerance	Parallelism tolerance	Recommended mean roughness value
Nominal dimension mm		Operating clearance					Ramax (Rzmax)
over	incl.	small	normal	large	max.	max.	µm
–	65	k5	h5	g6	IT3	IT3	0,1 (0,4)
65	80	k5	h5	f6			0,15 (0,63)
80	120	k5	g5	f6			0,2 (1)
120	160	k5	g5	f6			
160	180	k5	g5	e6			
180	200	j5	g5	e6			
200	250	j5	f6	e6			
250	315	h5	f6	e6			
315	415	g5	f6	d6			

¹⁾ The envelope requirement © applies.

Shaft raceway to DIN 617



If the surface of the shaft raceway is produced to DIN 617, the basic load ratings C_r in the product tables must be reduced by 15% ➤ 921 | 1.2.

Steels for the raceway

Through hardening steels



Through hardening steels in accordance with ISO 683-17 (e.g. 100Cr6) are suitable as materials for rolling bearing raceways in direct bearing arrangements. These steels can also be surface layer hardened.

Case hardening steels



Case hardening steels must correspond to DIN EN ISO 683-17 (e.g. 17MnCr5, 18CrNiMo7-6) or EN 10084 (e.g. 16MnCr5).

Steels for inductive surface layer hardening



For flame and induction hardening, steels in accordance with DIN EN ISO 683-17 (e.g. C56E2, 43CrMo4) or DIN 17212 (e.g. Cf53) should be used.

Raceway hardness of less than 670 HV



If the raceway fulfils the requirements for rolling bearing materials but the raceway hardness is less than 670 HV, the load on the bearing arrangement cannot be as high as the full load carrying capacity of the bearing. In order to determine the dynamic and static load carrying capacity of the bearing arrangement, the basic dynamic load rating C of the bearings must be multiplied by the reduction factor f_H (dynamic hardness factor) and the basic static load rating C_{0r} by the reduction factor f_{H0} (static hardness factor) ➤ 932 | 20 and ➤ 933 | 21.

20
Dynamic hardness factor at reduced hardness of raceways/rolling elements

f_H = dynamic hardness factor
HV, HRC = surface hardness

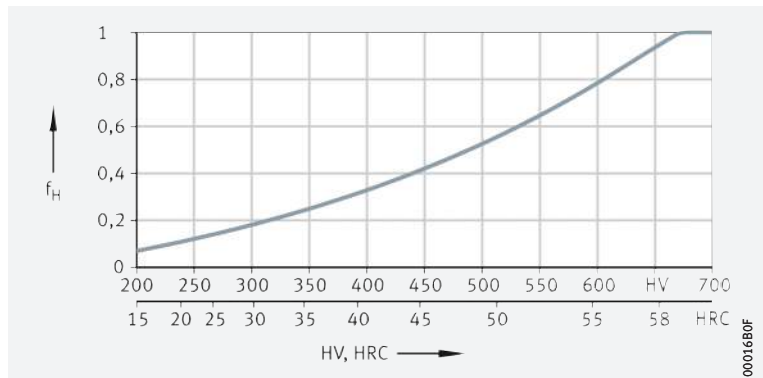

21

Static hardness factor at reduced hardness of raceways/rolling elements

f_{H0} = static hardness factor
HV, HRC = surface hardness

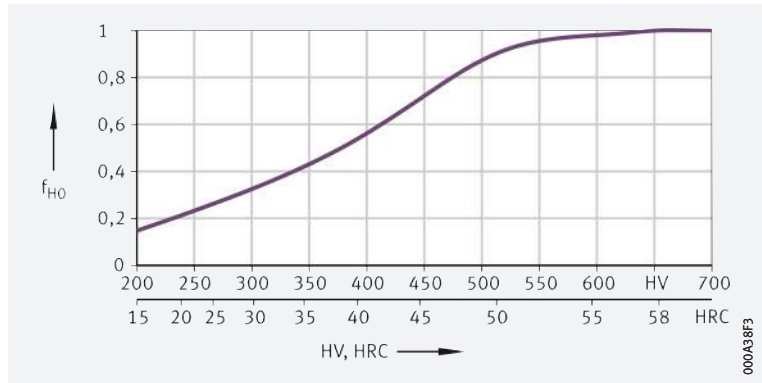

Approximation value for case hardening depth

Determining the case hardening depth

An approximation value for determining the minimum hardness depth is given in ▶ 868 | § 4. The reference value for the load present is the equivalent stress in accordance with the distortion energy hypothesis (DEH) as a function of the rolling element diameter D_w and the magnitude of the load.

§ 4 Case hardening depth

$$CHD \geq 0,052 \cdot D_w$$

Legend

CHD	mm	Case hardening depth
D_w	mm	Rolling element diameter.



The local hardness must always be above the local requisite hardness, which can be calculated from the equivalent stress.

Determining the surface hardening depth



In these surface hardening methods, the load and contact geometry must be taken into consideration when determining the requisite hardening depth.

For calculation of the surface hardening depth SHD ▶ 869 | § 5:

§ 5 Surface hardening depth

$$SHD \geq 140 \cdot D_w / R_{p0,2}$$

Legend

SHD	mm	Surface hardening depth
D_w	mm	Rolling element diameter
$R_{p0,2}$	N/mm ²	Yield point of base material.

1.17

Mounting and dismounting



The mounting and dismounting options for needle roller bearings with ribs, by thermal, hydraulic or mechanical methods, must be taken into consideration in the design of the bearing position.

Aligning needle roller bearings

Mounting using pressing mandrel

Due to the drawn outer cup, the bearings must be mounted using a special pressing mandrel ▶ 898. The marked side of the bearing should be in contact with the flange of the mandrel. A toroidal ring on the mandrel holds the bearing securely on the mandrel.

Rolling bearings must be handled with great care

Schaeffler Mounting Handbook

Rolling bearings are well-proven precision machine elements for the design of economical and reliable bearing arrangements, which offer high operational security. In order that these products can function correctly and achieve the envisaged operating life without detrimental effect, they must be handled with care.





The Schaeffler Mounting Handbook MH 1 gives comprehensive information about the correct storage, mounting, dismounting and maintenance of rotary rolling bearings ► <https://www.schaeffler.de/std/1D53>. It also provides information which should be observed by the designer, in relation to the mounting, dismounting and maintenance of bearings, in the original design of the bearing position. This book is available from Schaeffler on request.

1.18 Legal notice regarding data freshness

The further development of products may also result in technical changes to catalogue products

Of central interest to Schaeffler is the further development and optimisation of its products and the satisfaction of its customers. In order that you, as the customer, can keep yourself optimally informed about the progress that is being made here and with regard to the current technical status of the products, we publish any product changes which differ from the printed version in our electronic product catalogue.



We therefore reserve the right to make changes to the data and illustrations in this catalogue. This catalogue reflects the status at the time of printing. More recent publications released by us (as printed or digital media) will automatically precede this catalogue if they involve the same subject. Therefore, please always use our electronic product catalogue to check whether more up-to-date information or modification notices exist for your desired product.

Link to electronic product catalogue



The following link will take you to the Schaeffler electronic product catalogue: ► <https://medias.schaeffler.com>.

1.19 Further information



In addition to the data in this chapter, the following chapters in Technical principles must also be observed in the design of bearing arrangements:

- Determining the bearing size ► 34
- Rigidity ► 54
- Friction and increases in temperature ► 56
- Speeds ► 64
- Bearing data ► 97
- Lubrication ► 70
- Sealing ► 182
- Design of bearing arrangements ► 139
- Mounting and dismounting ► 191.





Needle roller bearings with ribs

Without inner ring
Open

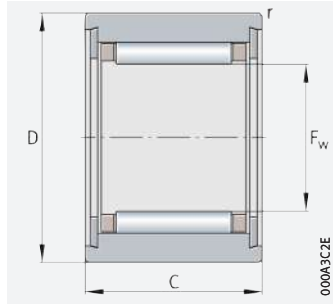

NK ($F_w \leq 10 \text{ mm}$)

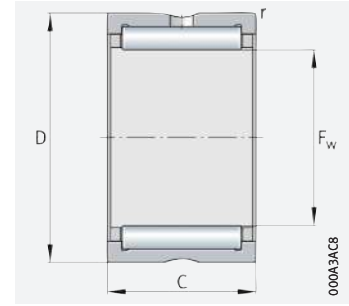

NK ($F_w \geq 12 \text{ mm}$), RNA49, RNA69

$F_w = 5 - 19 \text{ mm}$

Main dimensions			Basic load ratings		Fatigue limit load	Limiting speed	Speed rating	Mass	Designation
F_w	D	C	dyn. C_r	stat. C_{0r}	C_{ur}	n_G	$n_{\theta r}$	m	▶ 926 1.12 ▶ 927 1.13 X-life ▶ 920
			N	N					
5	10	10	2 650	1 920	295	39 000	55 000	3,1	NK5/10-TV-XL ²⁾
	10	12	3 400	2 650	435	39 000	54 000	3,7	NK5/12-TV-XL ²⁾
6	12	10	2 950	2 280	355	36 500	48 500	4,7	NK6/10-TV-XL ²⁾
	12	12	3 800	3 150	520	36 500	47 500	5,7	NK6/12-TV-XL ²⁾
7	14	10	3 250	2 650	410	34 500	43 000	6,9	NK7/10-TV-XL ²⁾
	14	12	4 150	3 600	600	34 500	42 000	8,2	NK7/12-TV-XL ²⁾
8	15	12	4 450	4 100	690	32 500	37 000	8,7	NK8/12-TV-XL ²⁾
	15	16	5 800	5 800	970	32 500	36 500	12	NK8/16-TV-XL ²⁾
9	16	12	5 100	5 000	840	31 000	32 000	10,3	NK9/12-TV-XL ²⁾
	16	16	6 600	7 100	1 190	31 000	32 000	12,8	NK9/16-TV-XL ²⁾
10	17	12	5 300	5 500	930	29 500	29 000	10,1	NK10/12-TV-XL ²⁾
	17	16	7 000	7 800	1 310	29 500	28 500	13,3	NK10/16-TV-XL ²⁾
12	19	12	7 200	7 100	1 280	26 500	22 400	12,1	NK12/12-XL
	19	16	10 100	11 000	1 920	26 500	21 600	15,9	NK12/16-XL
14	22	16	15 400	17 100	2 850	24 600	16 800	21,4	NK14/16-D-XL
	22	16	11 400	11 500	2 100	24 600	18 600	20,7	NK14/16-XL
	22	20	14 500	15 600	2 700	24 600	18 300	25,5	NK14/20-XL
	22	13	9 600	9 200	1 630	24 600	17 800	16,5	RNA4900-XL
15	23	16	12 100	12 700	2 320	23 900	17 300	21,8	NK15/16-XL
	23	20	15 400	17 200	3 000	23 900	17 000	26,6	NK15/20-XL
16	24	16	12 800	13 900	2 550	23 200	16 200	22,4	NK16/16-XL
	24	20	16 300	18 800	3 250	23 200	15 900	28,4	NK16/20-XL
	24	13	10 600	10 900	1 940	23 200	15 300	17,4	RNA4901-XL
	24	22	18 100	21 600	3 800	23 200	14 300	31	RNA6901-XL
17	25	16	13 500	15 000	2 750	22 600	15 300	23,7	NK17/16-XL
	25	20	17 100	20 400	3 550	22 600	15 000	29,8	NK17/20-XL
18	26	16	14 100	16 200	3 000	22 100	14 400	24,9	NK18/16-XL
	26	20	17 900	22 000	3 850	22 100	14 100	31,4	NK18/20-XL
19	27	16	14 700	17 400	3 200	21 600	13 700	26,1	NK19/16-XL
	27	20	18 700	23 600	4 150	21 600	13 400	32,2	NK19/20-XL

medias ▶ <https://www.schaeffler.de/std/1E00>

1) For unsealed needle roller bearings, dimensionally matched sealing rings of series G or SD can be used to provide protection against contamination.

2) With closing rings, without lubrication hole and groove.



Dimensions		Suitable sealing rings ¹⁾	
F_w	r	► 1026	
	min.		
5	0,15	GR5×10×2	-
	0,15	GR5×10×2	-
6	0,15	GR6×12×2	-
	0,15	GR6×12×2	-
7	0,3	GR7×14×2	-
	0,3	GR7×14×2	-
8	0,3	G8×15×3	SD8×15×3
	0,3	G5×15×3	SD8×15×3
9	0,3	G9×16×3	-
	0,3	G9×16×3	-
10	0,3	G10×17×3	SD10×17×3
	0,3	G10×17×3	SD10×17×3
12	0,3	G12×19×3	SD12×19×3
	0,3	G12×19×3	SD12×19×3
14	0,3	G14×22×3	SD14×22×3
	0,3	G14×22×3	SD14×22×3
	0,3	G14×22×3	SD14×22×3
	0,3	G14×22×3	SD14×22×3
15	0,3	G15×23×3	SD15×23×3
	0,3	G15×23×3	SD15×23×3
16	0,3	G16×24×3	SD16×24×3
	0,3	G16×24×3	SD16×24×3
	0,3	G16×24×3	SD16×24×3
	0,3	G16×24×3	SD16×24×3
17	0,3	G17×25×3	SD17×25×3
	0,3	G17×25×3	SD17×25×3
18	0,3	G18×26×4	SD18×26×4
	0,3	G18×26×4	SD18×26×4
19	0,3	G19×27×4	SD19×27×4
	0,3	G19×27×4	SD19×27×4



Needle roller bearings with ribs

Without inner ring
Open

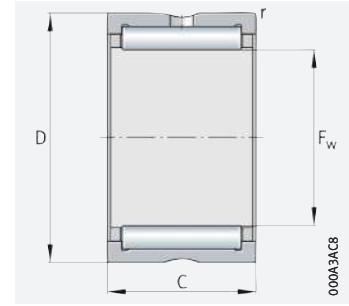

NK, NKS, RNA49, RNA69

F_w = 20 – 29 mm

Main dimensions			Basic load ratings		Fatigue limit load	Limiting speed	Speed rating	Mass	Designation
F _w	D	C	dyn. C _r	stat. C _{0r}	C _{ur}	n _G	n _{thr}	m	▶ 926 1.12 ▶ 927 1.13 X-life ▶ 920
			N	N	N	min ⁻¹	min ⁻¹	≈ g	
20	28	16	18 500	23 900	4 050	21 100	12 100	28,4	NK20/16-D-XL
	28	16	14 600	17 500	3 200	21 100	13 200	27	NK20/16-XL
	28	20	18 600	23 800	4 150	21 100	12 900	33,9	NK20/20-XL
	28	13	12 000	13 600	2 430	21 100	12 000	21,7	RNA4902-XL
	28	23	19 500	25 500	4 450	21 100	11 700	39,7	RNA6902-XL
	32	20	26 000	25 000	4 400	20 000	11 800	48,7	NKS20-XL
21	29	16	15 200	18 700	3 450	20 600	12 600	28,1	NK21/16-XL
	29	20	19 300	25 500	4 450	20 600	12 300	35,2	NK21/20-XL
22	30	16	15 800	19 900	3 650	20 000	12 000	30	NK22/16-XL
	30	20	20 000	27 000	4 700	20 000	11 700	37	NK22/20-XL
	30	13	12 400	14 600	2 600	20 000	10 900	22,2	RNA4903-XL
	30	23	21 100	29 000	5 100	20 000	10 500	42,4	RNA6903-XL
	35	20	27 500	28 000	4 900	18 500	10 900	61,5	NKS22-XL
24	32	16	16 900	22 300	4 100	18 500	11 000	31,9	NK24/16-XL
	32	20	21 400	30 500	5 300	18 500	10 700	40	NK24/20-XL
	37	20	29 500	31 000	5 400	17 200	10 100	65,5	NKS24-XL
25	33	16	16 800	22 400	4 150	17 800	10 700	32,6	NK25/16-XL
	33	20	21 300	30 500	5 300	17 800	10 400	42	NK25/20-XL
	37	17	23 700	25 500	4 600	16 900	9 900	52,3	RNA4904-XL
	37	30	40 500	51 000	9 100	16 900	9 500	100	RNA6904-XL
	38	20	31 000	33 500	5 800	16 600	9 700	68,1	NKS25-XL
26	34	16	17 300	23 600	4 350	17 200	10 300	34	NK26/16-XL
	34	20	22 000	32 000	5 600	17 200	10 100	42	NK26/20-XL
28	37	20	29 000	41 500	7 400	15 800	8 800	58	NK28/20-D-XL
	37	20	24 800	34 000	5 900	15 800	9 300	52,2	NK28/20-XL
	37	30	37 000	57 000	10 500	15 800	9 000	82	NK28/30-XL
	39	17	26 000	29 500	5 300	15 300	8 600	50,2	RNA49/22-XL
	39	30	42 000	55 000	9 900	15 300	8 400	98	RNA69/22-XL
	42	20	32 500	36 500	6 400	15 100	8 900	83,6	NKS28-XL
29	38	20	27 500	39 000	6 900	15 300	8 700	50	NK29/20-TV-XL
	38	30	37 000	57 000	10 600	15 300	8 800	84,3	NK29/30-XL

medias ▶ <https://www.schaeffler.de/std/1E01>

1) For unsealed needle roller bearings, dimensionally matched sealing rings of series G or SD can be used to provide protection against contamination.



Dimensions		Suitable sealing rings ¹⁾	
F _w	r	► 1026	
	min.		
20	0,3	G20×28×4	SD20×28×4
	0,3	G20×28×4	SD20×28×4
	0,3	G20×28×4	SD20×28×4
	0,3	G20×28×4	SD20×28×4
	0,3	G20×28×4	SD20×28×4
	0,6	–	–
21	0,3	G21×29×4	–
	0,3	G21×29×4	–
22	0,3	G22×30×4	SD22×30×4
	0,3	G22×30×4	SD22×30×4
	0,3	G22×30×4	SD22×30×4
	0,3	G22×30×4	SD22×30×4
	0,6	–	–
24	0,3	G24×32×4	–
	0,3	G24×32×4	–
	0,6	–	–
25	0,3	G25×33×4	SD25×33×4
	0,3	G25×33×4	SD25×33×4
	0,3	–	–
	0,3	–	–
	0,6	–	–
26	0,3	G26×34×4	SD26×34×4
	0,3	G26×34×4	SD26×34×4
28	0,3	G28×37×4	–
	0,3	G28×37×4	–
	0,3	G28×37×4	–
	0,3	–	–
	0,3	–	–
	0,6	–	–
29	0,3	G29×38×4	–
	0,3	G29×38×4	–





Needle roller bearings with ribs

Without inner ring
Open

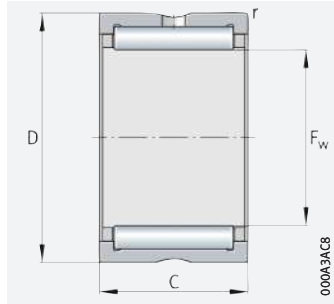

NK, NKS, RNA49, RNA69

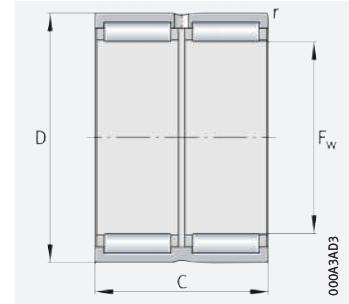

RNA69..-ZW

F_w = 30 – 42 mm

Main dimensions			Basic load ratings		Fatigue limit load	Limiting speed	Speed rating	Mass	Designation
F _w	D	C	dyn. C _r	stat. C _{0r}	C _{ur}	n _G	n _{gr}	m	▶926 1.12 ▶927 1.13 X-life ▶920
			N	N	N	min ⁻¹	min ⁻¹	≈ g	
30	40	20	27 500	35 500	7 300	14 800	9 600	61	NK30/20-TW-XL
	40	20	28 000	41 000	7 200	14 800	8 500	61	NK30/20-TV-XL
	40	30	42 000	69 000	12 700	14 800	8 200	92,4	NK30/30-TV-XL
	42	17	26 500	31 500	5 700	14 400	8 100	61	RNA4905-XL
	42	30	44 000	59 000	10 600	14 400	7 900	112	RNA6905-XL
	45	22	36 500	40 000	6 900	14 000	8 500	104	NKS30-XL
32	42	20	29 500	44 500	7 800	14 000	8 000	64	NK32/20-TV-XL
	42	30	39 000	63 000	11 700	14 000	8 200	102	NK32/30-XL
	45	17	27 500	33 500	6 100	13 600	7 600	73,2	RNA49/28-XL
	45	30	45 500	63 000	11 400	13 600	7 400	135	RNA69/28-XL
	47	22	38 000	43 500	7 400	13 200	8 000	110	NKS32-XL
35	45	20	31 000	48 500	8 500	12 900	7 400	69,4	NK35/20-TV-XL
	45	30	46 000	81 000	15 000	12 900	7 100	106	NK35/30-TV-XL
	47	17	28 500	35 500	6 400	12 600	6 900	69,4	RNA4906-XL
	47	30	49 000	71 000	12 800	12 600	6 600	126	RNA6906-XL
	50	22	39 500	47 000	8 000	12 300	7 400	118	NKS35-XL
37	47	20	34 000	56 000	9 900	12 300	6 800	83	NK37/20-D-XL
	47	20	28 000	43 500	7 600	12 300	7 400	77	NK37/20-XL
	47	30	42 000	73 000	13 500	12 300	7 200	113	NK37/30-XL
	52	22	41 500	50 000	8 600	11 700	7 100	123	NKS37-XL
38	48	20	29 000	45 000	7 900	12 000	7 200	79,4	NK38/20-XL
	48	30	43 000	76 000	14 000	12 000	7 000	116	NK38/30-XL
40	50	20	33 500	56 000	9 800	11 400	6 500	78	NK40/20-TV-XL
	50	30	44 000	79 000	14 600	11 400	6 700	125	NK40/30-XL
	52	20	34 500	47 500	8 900	11 100	6 400	89,1	RNA49/32-XL
	52	36	53 000	82 000	15 100	11 100	6 500	162	RNA69/32-ZW-XL
	55	22	42 500	54 000	9 200	10 900	6 600	129	NKS40-XL
42	52	20	30 000	49 000	8 600	10 900	6 600	85,8	NK42/20-XL
	52	30	44 500	82 000	15 200	10 900	6 400	130	NK42/30-XL
	55	20	35 500	50 000	9 400	10 700	6 100	107	RNA4907-XL
	55	36	54 000	86 000	15 900	10 700	6 200	193	RNA6907-ZW-XL

medias ▶ <https://www.schaeffler.de/std/1E02>

1) For unsealed needle roller bearings, dimensionally matched sealing rings of series G or SD can be used to provide protection against contamination.



Dimensions		Suitable sealing rings ¹⁾	
F _w	r	► 1026	
	min.		
30	0,3	G30×40×4	SD30×40×4
	0,3	G30×40×4	SD30×40×4
	0,3	G30×40×4	SD30×40×4
	0,3	-	-
	0,3	-	-
	0,6	-	-
32	0,3	G32×42×4	SD32×42×4
	0,3	G32×42×4	SD32×42×4
	0,3	G32×45×4	-
	0,3	G32×45×4	-
	0,6	-	-
35	0,3	G35×45×4	SD35×45×4
	0,3	G35×45×4	SD35×45×4
	0,3	-	-
	0,3	-	-
	0,6	-	-
37	0,3	G37×47×4	SD37×47×4
	0,3	G37×47×4	SD37×47×4
	0,3	G37×47×4	SD37×47×4
	0,6	-	-
38	0,3	G38×48×4	SD38×48×4
	0,3	G38×48×4	SD38×48×4
40	0,3	G40×50×4	SD40×50×4
	0,3	G40×50×4	SD40×50×4
	0,6	G40×52×5	SD40×52×5
	0,6	G40×52×5	SD40×52×5
	0,6	-	-
42	0,3	G42×52×4	SD42×52×4
	0,3	G42×52×4	SD42×52×4
	0,6	-	-
	0,6	-	-



Needle roller bearings with ribs

Without inner ring
Open

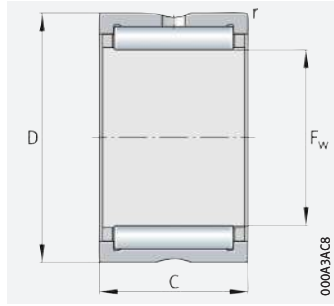

NK, NKS, RNA49

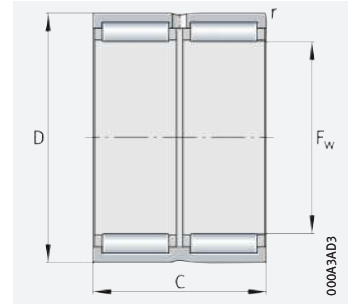

RNA69...-ZW

F_w = 43 – 65 mm

Main dimensions			Basic load ratings		Fatigue limit load C _{ur}	Limiting speed n _G	Speed rating n _{GR}	Mass m	Designation
F _w	D	C	dyn. C _r	stat. C _{0r}					
			N	N	N	min ⁻¹	min ⁻¹	≈ g	
43	53	20	30 500	51 000	8 900	10 700	6 500	86	NK43/20-XL
	53	30	45 500	85 000	15 800	10 700	6 300	133	NK43/30-XL
	58	22	44 000	57 000	9 800	10 200	6 200	139	NKS43-XL
45	55	20	35 000	62 000	10 800	10 200	5 900	85,3	NK45/20-TV-XL
	55	30	52 000	103 000	19 100	10 200	5 700	132	NK45/30-TV-XL
	60	22	45 500	60 000	10 400	9 800	6 000	145	NKS45-XL
47	57	20	32 500	56 000	9 900	9 800	6 000	94,5	NK47/20-XL
	57	30	48 500	94 000	17 500	9 800	5 800	142	NK47/30-XL
48	62	22	48 500	67 000	11 500	9 200	5 300	140	RNA4908-XL
	62	40	74 000	116 000	19 400	9 200	5 400	256	RNA6908-ZW-XL
50	62	25	48 500	87 000	14 800	9 200	5 400	146	NK50/25-TV-XL
	62	35	67 000	132 000	23 900	9 200	5 200	207	NK50/35-TV-XL
	65	22	48 000	67 000	11 500	8 900	5 500	157	NKS50-XL
52	68	22	51 000	73 000	12 600	8 600	4 900	182	RNA4909-XL
	68	40	79 000	127 000	21 400	8 600	4 950	338	RNA6909-ZW-XL
55	68	25	57 000	111 000	19 400	8 400	4 700	195	NK55/25-D-XL
	68	25	45 500	82 000	14 000	8 400	5 200	180	NK55/25-XL
	68	35	60 000	118 000	21 300	8 400	5 200	250	NK55/35-XL
	72	22	51 000	74 000	12 700	8 200	5 100	221	NKS55-XL
58	72	22	53 000	80 000	13 800	7 800	4 350	163	RNA4910-XL
	72	40	82 000	139 000	23 400	7 800	4 400	310	RNA6910-ZW-XL
60	72	25	53 000	103 000	17 500	7 700	4 600	170	NK60/25-TV-XL
	72	35	63 000	130 000	23 500	7 700	4 800	258	NK60/35-XL
	80	28	71 000	98 000	17 300	7 400	4 750	335	NKS60-XL
63	80	25	65 000	100 000	17 300	7 200	4 150	255	RNA4911-XL
	80	45	102 000	176 000	30 000	7 200	4 200	470	RNA6911-ZW-XL
65	78	25	50 000	98 000	16 700	7 200	4 500	221	NK65/25-XL
	78	35	66 000	142 000	25 500	7 200	4 450	310	NK65/35-XL
	85	28	75 000	108 000	19 100	6 900	4 400	356	NKS65-XL

medias ► <https://www.schaeffler.de/std/1E03>

¹⁾ For unsealed needle roller bearings, dimensionally matched sealing rings of series G or SD can be used to provide protection against contamination.



Dimensions		Suitable sealing rings ¹⁾	
F _w	r	► 1026	
	min.		
43	0,3	G43×53×4	-
	0,3	G43×53×4	-
	0,6	-	-
45	0,3	G45×55×4	SD45×55×4
	0,3	G45×55×4	SD45×55×4
	0,6	-	-
47	0,3	-	-
	0,3	-	-
48	0,6	-	-
	0,6	-	-
50	0,6	G50×62×5	SD50×62×5
	0,6	G50×62×5	SD50×62×5
	1	-	-
52	0,6	-	-
	0,6	-	-
55	0,6	-	-
	0,6	-	-
	0,6	-	-
	1	-	-
58	0,6	-	-
	0,6	-	-
60	0,6	-	-
	0,6	-	-
	1,1	-	-
63	1	-	-
	1	-	-
65	0,6	-	-
	0,6	-	-
	1,1	-	-





Needle roller bearings with ribs

Without inner ring
Open

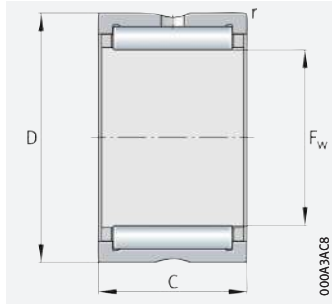

NK, NKS, RNA48, RNA49

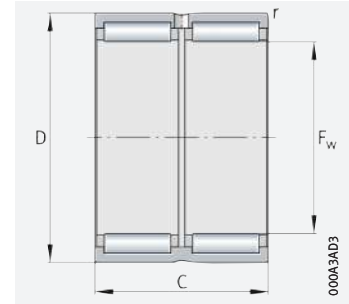

RNA69...-ZW

F_w = 68 – 240 mm

Main dimensions			Basic load ratings		Fatigue limit load C _{ur} N	Limiting speed n _G min ⁻¹	Speed rating n _{Dr} min ⁻¹	Mass m ≈ g	Designation	Dimensions r min.
F _w	D	C	dyn. C _r N	stat. C _{0r} N						
68	82	25	49 500	89 000	15 200	6 800	4 500	241	NK68/25-XL	0,6
	82	35	70 000	139 000	25 500	6 800	4 350	338	NK68/35-XL	0,6
	85	25	68 000	108 000	18 800	6 700	3 850	275	RNA4912-XL	1
	85	45	106 000	191 000	32 500	6 700	3 850	488	RNA6912-ZW-XL	1
70	85	25	50 000	92 000	15 700	6 600	4 450	260	NK70/25-XL	0,6
	85	35	71 000	144 000	26 500	6 600	4 300	370	NK70/35-XL	0,6
	90	28	77 000	113 000	20 000	6 400	4 200	380	NKS70-XL	1,1
72	90	25	69 000	112 000	19 500	6 300	3 650	312	RNA4913-XL	1
	90	45	108 000	198 000	33 500	6 300	3 650	580	RNA6913-ZW-XL	1
73	90	25	60 000	100 000	17 500	6 300	4 150	302	NK73/25-XL	1
	90	35	85 000	156 000	27 000	6 300	4 050	428	NK73/35-XL	1
75	92	25	61 000	104 000	18 200	6 100	4 050	315	NK75/25-XL	1
	92	35	87 000	162 000	28 000	6 100	3 950	445	NK75/35-XL	1
	95	28	81 000	123 000	21 900	6 000	3 950	402	NKS75-XL	1,1
80	95	25	63 000	119 000	19 700	5 800	3 750	301	NK80/25-XL	1
	95	35	89 000	184 000	32 500	5 800	3 650	425	NK80/35-XL	1
	100	30	95 000	156 000	27 500	5 700	3 400	460	RNA4914-XL	1
	100	54	145 000	265 000	47 500	5 700	3 450	857	RNA6914-ZW-XL	1
85	105	25	78 000	123 000	21 700	5 400	3 550	425	NK85/25-XL	1
	105	35	111 000	193 000	34 500	5 400	3 450	600	NK85/35-XL	1
	105	30	97 000	162 000	28 500	5 400	3 200	489	RNA4915-XL	1
	105	54	147 000	275 000	49 500	5 400	3 250	935	RNA6915-ZW-XL	1
90	110	25	81 000	132 000	23 300	5 100	3 400	450	NK90/25-XL	1
	110	35	116 000	208 000	37 000	5 100	3 250	630	NK90/35-XL	1
	110	30	101 000	174 000	30 500	5 100	3 000	516	RNA4916-XL	1
	110	54	153 000	300 000	53 000	5 100	3 050	987	RNA6916-ZW-XL	1
95	115	26	83 000	137 000	24 000	4 850	3 300	490	NK95/26-XL	1
	115	36	121 000	223 000	39 500	4 850	3 150	680	NK95/36-XL	1

medias ► <https://www.schaeffler.de/std/1E04>



Main dimensions			Basic load ratings		Fatigue limit load	Limiting speed	Speed rating	Mass	Designation	Dimensions
F_w	D	C	dyn. C_r N	stat. C_{0r} N	C_{ur} N	n_G min^{-1}	n_{gr} min^{-1}	m \approx g	▶ 926 1.12 ▶ 927 1.13 X-life ▶ 920	r min.
100	120	26	86 000	146 000	25 000	4 600	3 150	515	NK100/26-XL	1
	120	36	125 000	237 000	41 500	4 600	3 000	715	NK100/36-XL	1
	120	35	125 000	237 000	41 500	4 600	2 800	657	RNA4917-XL	1,1
	120	63	188 000	400 000	71 000	4 600	2 850	1 200	RNA6917-ZW-XL	1,1
105	125	26	89 000	155 000	26 500	4 400	3 050	540	NK105/26-XL	1
	125	36	129 000	250 000	43 500	4 400	2 850	713	NK105/36-XL	1
	125	35	129 000	250 000	43 500	4 400	2 650	745	RNA4918-XL	1,1
	125	63	195 000	425 000	74 000	4 400	2 700	1 330	RNA6918-ZW-XL	1,1
110	130	30	111 000	210 000	35 500	4 200	2 800	650	NK110/30-XL	1,1
	130	40	143 000	290 000	50 000	4 200	2 750	830	NK110/40-XL	1,1
	130	35	131 000	260 000	44 500	4 200	2 500	719	RNA4919-XL	1,1
	130	63	197 000	440 000	76 000	4 200	2 550	1 460	RNA6919-ZW-XL	1,1
115	140	40	144 000	270 000	45 500	4 000	2 650	1 150	RNA4920-XL	1,1
120	140	30	106 000	216 000	36 000	3 900	2 340	670	RNA4822-XL	1
125	150	40	149 000	290 000	47 500	3 700	2 430	1 240	RNA4922-XL	1,1
130	150	30	112 000	239 000	39 000	3 600	2 120	730	RNA4824-XL	1
135	165	45	205 000	390 000	64 000	3 400	2 250	1 860	RNA4924-XL	1,1
145	165	35	134 000	310 000	48 500	3 250	2 000	990	RNA4826-XL	1,1
150	180	50	229 000	470 000	74 000	3 100	2 080	2 210	RNA4926-XL	1,5
155	175	35	136 000	325 000	50 000	3 050	1 870	1 050	RNA4828-XL	1,1
160	190	50	237 000	500 000	78 000	2 900	1 910	2 350	RNA4928-XL	1,5
165	190	40	172 000	400 000	62 000	2 850	1 830	1 600	RNA4830-XL	1,1
175	200	40	181 000	435 000	66 000	2 700	1 700	1 700	RNA4832-XL	1,1
185	215	45	209 000	510 000	75 000	2 550	1 640	2 540	RNA4834-XL	1,1
195	225	45	219 000	550 000	80 000	2 420	1 510	2 680	RNA4836-XL	1,1
210	240	50	255 000	690 000	100 000	2 250	1 360	3 210	RNA4838-XL	1,5
220	250	50	260 000	720 000	102 000	2 150	1 280	3 350	RNA4840-XL	1,5
240	270	50	275 000	790 000	110 000	1 980	1 130	3 620	RNA4844-XL	1,5

medias ▶ <https://www.schaeffler.de/std/1E05>



Needle roller bearings with ribs

Without inner ring

Open

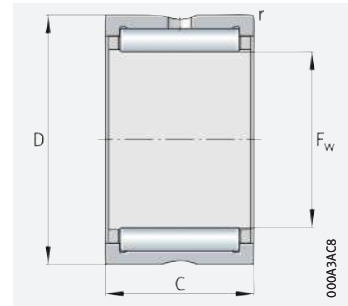

RNA48

F_w = 265 – 415 mm

Main dimensions			Basic load ratings		Fatigue limit load C _{ur} N	Limiting speed n _G min ⁻¹	Speed rating n _{dr} min ⁻¹	Mass m ≈ g	Designation	Dimensions r min.
F _w	D	C	dyn. C _r N	stat. C _{0r} N						
265	300	60	400 000	1 080 000	150 000	1 780	980	5 400	RNA4848-XL	2
285	320	60	415 000	1 160 000	158 000	1 660	890	5 800	RNA4852-XL	2
305	350	69	510 000	1 300 000	175 000	1 540	850	9 300	RNA4856-XL	2
330	380	80	700 000	1 770 000	235 000	1 420	740	12 700	RNA4860-XL	2,1
350	400	80	710 000	1 850 000	242 000	1 340	680	13 400	RNA4864-XL	2,1
370	420	80	730 000	1 940 000	249 000	1 270	640	14 000	RNA4868-XL	2,1
390	440	80	740 000	2 020 000	255 000	1 210	600	14 800	RNA4872-XL	2,1
415	480	100	1 130 000	2 900 000	370 000	1 130	520	26 000	RNA4876-XL	2,1

medias ► <https://www.schaeffler.de/std/1E06>



Needle roller bearings with ribs

With inner ring
Open

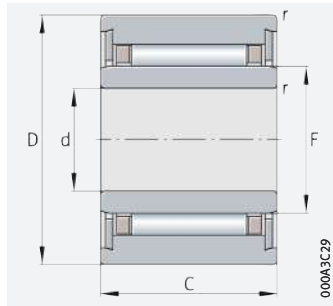

NKI ($d \leq 7 \text{ mm}$)

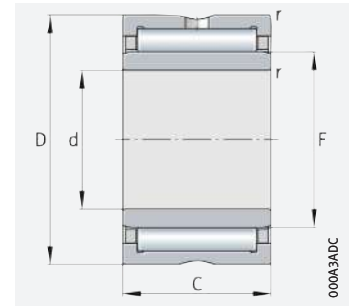

NKI ($d \geq 9 \text{ mm}$), NKIS, NA49, NA69 ($d \leq 30 \text{ mm}$)

d = 5 – 35 mm

Main dimensions			Basic load ratings		Fatigue limit load	Limiting speed	Speed rating	Mass	Designation	Dimensions		
d	D	B	dyn. C_r	stat. C_{0r}	C_{ur}	n_G	$n_{\partial r}$	m		F	r	s
			N	N	N	min^{-1}	min^{-1}	$\approx \text{g}$	▶926 1.12 ▶927 1.13 X-life ▶920	min.		
5	15	12	4 450	4 100	690	32 500	32 500	11,5	NKI5/12-TV-XL ¹⁾	8	0,3	1,5
	15	16	5 800	5 800	970	32 500	32 000	15,3	NKI5/16-TV-XL ¹⁾	8	0,3	2
6	16	12	5 100	5 000	840	31 000	28 500	13,5	NKI6/12-TV-XL ¹⁾	9	0,3	1,5
	16	16	6 600	7 100	1 190	31 000	28 000	17,4	NKI6/16-TV-XL ¹⁾	9	0,3	2
7	17	12	5 300	5 500	930	29 500	26 000	13,7	NKI7/12-TV-XL ¹⁾	10	0,3	1,5
	17	16	7 000	7 800	1 310	29 500	25 500	18,2	NKI7/16-TV-XL ¹⁾	10	0,3	2
9	19	12	7 200	7 100	1 280	26 500	20 200	16,6	NKI9/12-XL	12	0,3	1,5
	19	16	10 100	11 000	1 920	26 500	19 500	21,9	NKI9/16-XL	12	0,3	2
10	22	16	11 400	11 500	2 100	24 600	16 400	29,4	NKI10/16-XL	14	0,3	0,5
	22	20	14 500	15 600	2 700	24 600	16 100	37,1	NKI10/20-XL	14	0,3	0,5
	22	13	9 600	9 200	1 630	24 600	16 400	23	NA4900-XL	14	0,3	0,5
12	24	16	12 800	13 900	2 550	23 200	14 500	33,3	NKI12/16-XL	16	0,3	0,5
	24	20	16 300	18 800	3 250	23 200	14 200	41,9	NKI12/20-XL	16	0,3	0,5
	24	13	10 600	10 900	1 940	23 200	14 200	26	NA4901-XL	16	0,3	0,5
	24	22	18 100	21 600	3 800	23 200	13 300	46	NA6901-XL	16	0,3	1
15	27	16	14 700	17 400	3 200	21 600	12 400	38,8	NKI15/16-XL	19	0,3	0,5
	27	20	18 700	23 600	4 150	21 600	12 100	48,7	NKI15/20-XL	19	0,3	0,5
	28	13	12 000	13 600	2 430	21 100	11 200	34	NA4902-XL	20	0,3	0,5
	28	23	19 500	25 500	4 450	21 100	10 900	63,6	NA6902-XL	20	0,3	1
	35	20	27 500	28 000	4 900	18 500	9 400	92	NKIS15-XL	22	0,6	0,5
17	29	16	15 200	18 700	3 450	20 600	11 400	42,4	NKI17/16-XL	21	0,3	0,5
	29	20	19 300	25 500	4 450	20 600	11 200	53,4	NKI17/20-XL	21	0,3	0,5
	30	13	12 400	14 600	2 600	20 000	10 200	37	NA4903-XL	22	0,3	0,5
	30	23	21 100	29 000	5 100	20 000	9 800	72	NA6903-XL	22	0,3	1
	37	20	29 500	31 000	5 400	17 200	8 800	98	NKIS17-XL	24	0,6	0,5
20	32	16	16 900	22 300	4 100	18 500	10 100	49	NKI20/16-XL	24	0,3	0,5
	32	20	21 400	30 500	5 300	18 500	9 900	61	NKI20/20-XL	24	0,3	0,5
	37	17	23 700	25 500	4 600	16 900	9 400	75,2	NA4904-XL	25	0,3	0,8
	37	30	40 500	51 000	9 100	16 900	8 900	141	NA6904-XL	25	0,3	1
	42	20	32 500	36 500	6 400	15 100	7 700	129	NKIS20-XL	28	0,6	0,5

medias ▶ <https://www.schaeffler.de/std/1E07>

¹⁾ With closing rings, without lubrication hole and groove.

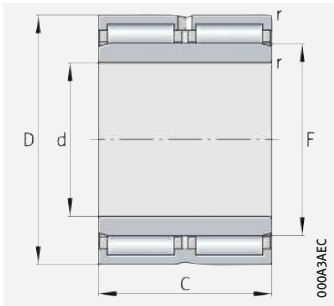

NA69...-ZW

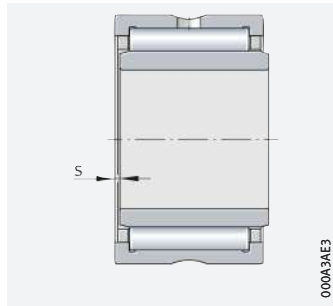

Axial displacement "s"

Main dimensions			Basic load ratings		Fatigue limit load	Limiting speed	Speed rating	Mass	Designation ▶926 1.12 ▶927 1.13 X-life ▶920	Dimensions		
d	D	B	dyn. C _r	stat. C _{0r}	C _{ur}	n _G	n _{∅r}	m		F	r	s
			N	N	N	min ⁻¹	min ⁻¹	≈ g			min.	
22	34	16	17 300	23 600	4 350	17 200	9 500	52	NKI22/16-XL	26	0,3	0,5
	34	20	22 000	32 000	5 600	17 200	9 300	65,4	NKI22/20-XL	26	0,3	0,5
	39	17	26 000	29 500	5 300	15 300	8 100	80	NA49/22-XL	28	0,3	0,8
	39	30	42 000	55 000	9 900	15 300	7 900	150	NA69/22-XL	28	0,3	0,5
25	38	20	27 500	39 000	6 900	15 300	8 100	75,8	NKI25/20-TV-XL	29	0,3	1
	38	30	37 000	57 000	10 600	15 300	8 200	124	NKI25/30-XL	29	0,3	1,5
	42	17	26 500	31 500	5 700	14 400	7 700	88	NA4905-XL	30	0,3	0,8
	42	30	44 000	59 000	10 600	14 400	7 500	161	NA6905-XL	30	0,3	1
	47	22	38 000	43 500	7 400	13 200	7 100	162	NKIS25-XL	32	0,6	1
28	42	20	29 500	44 500	7 800	14 000	7 500	92,4	NKI28/20-TV-XL	32	0,3	1
	42	30	39 000	63 000	11 700	14 000	7 600	146	NKI28/30-XL	32	0,3	1,5
	45	17	27 500	33 500	6 100	13 600	7 400	97,7	NA49/28-XL	32	0,3	0,8
	45	30	45 500	63 000	11 400	13 600	7 100	182	NA69/28-XL	32	0,3	1
30	45	20	31 000	48 500	8 500	12 900	6 800	108	NKI30/20-TV-XL	35	0,3	0,5
	45	30	46 000	81 000	15 000	12 900	6 600	165	NKI30/30-TV-XL	35	0,3	1
	47	17	28 500	35 500	6 400	12 600	6 600	101	NA4906-XL	35	0,3	0,8
	47	30	49 000	71 000	12 800	12 600	6 300	192	NA6906-XL	35	0,3	1
	52	22	41 500	50 000	8 600	11 700	6 400	184	NKIS30-XL	37	0,6	1
32	47	20	28 000	43 500	7 600	12 300	6 900	118	NKI32/20-XL	37	0,3	0,5
	47	30	42 000	73 000	13 500	12 300	6 600	180	NKI32/30-XL	37	0,3	1
	52	20	34 500	47 500	8 900	11 100	6 000	158	NA49/32-XL	40	0,6	0,8
	52	36	53 000	82 000	15 100	11 100	6 100	288	NA69/32-ZW-XL	40	0,6	0,5
35	50	20	32 500	48 500	9 900	11 400	6 900	122	NKI35/20-TW-XL	40	0,3	0,5
	50	20	33 500	56 000	9 800	11 400	6 100	122	NKI35/20-TV-XL	40	0,3	0,5
	50	30	44 000	79 000	14 600	11 400	6 200	193	NKI35/30-XL	40	0,3	1
	55	20	35 500	50 000	9 400	10 700	5 800	170	NA4907-XL	42	0,6	0,8
	55	36	54 000	86 000	15 900	10 700	5 900	310	NA6907-ZW-XL	42	0,6	0,5
	58	22	44 000	57 000	9 800	10 200	5 600	220	NKIS35-XL	43	0,6	0,5

medias ▶ <https://www.schaeffler.de/std/1E08>





Needle roller bearings with ribs

With inner ring
Open

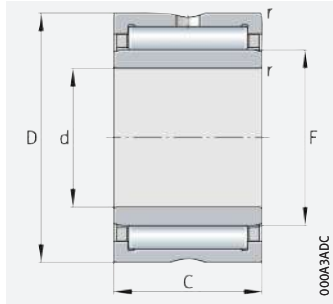

NKI, NKIS, NA49

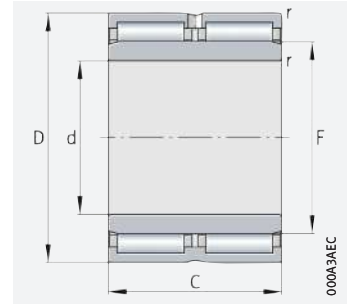

NA69..-ZW

d = 38 – 95 mm

Main dimensions			Basic load ratings		Fatigue limit load C_{ur} N	Limiting speed n_G min ⁻¹	Speed rating $n_{\theta r}$ min ⁻¹	Mass m ≈ g	Designation	Dimensions		
d	D	B	dyn. C_r N	stat. C_{0r} N						F	r	s
38	53	20	30 500	51 000	8 900	10 700	6 000	136	NKI38/20-XL	43	0,3	0,5
	53	30	45 500	85 000	15 800	10 700	5 900	207		NKI38/30-XL	43	0,3
40	55	20	35 000	62 000	10 800	10 200	5 600	136	NKI40/20-TV-XL	45	0,3	0,5
	55	30	54 000	97 000	18 200	10 200	5 900	216	NKI40/30-TW-XL	45	0,3	1
	55	30	52 000	103 000	19 100	10 200	5 400	216	NKI40/30-TV-XL	45	0,3	1
	62	22	48 500	67 000	11 500	9 200	5 000	230	NA4908-XL	48	0,6	1
	62	40	74 000	116 000	19 400	9 200	5 100	430	NA6908-ZW-XL	48	0,6	0,5
	65	22	48 000	67 000	11 500	8 900	4 850	281	NKIS40-XL	50	1	0,5
42	57	20	32 500	56 000	9 900	9 800	5 600	148	NKI42/20-XL	47	0,3	0,5
	57	30	48 500	94 000	17 500	9 800	5 400	222	NKI42/30-XL	47	0,3	1
45	62	25	48 500	87 000	14 800	9 200	5 100	217	NKI45/25-TV-XL	50	0,6	1,5
	62	35	67 000	132 000	23 900	9 200	4 950	308	NKI45/35-TV-XL	50	0,6	2
	68	22	51 000	73 000	12 600	8 600	4 700	271	NA4909-XL	52	0,6	1
	68	40	79 000	127 000	21 400	8 600	4 750	495	NA6909-ZW-XL	52	0,6	0,5
	72	22	51 000	74 000	12 700	8 200	4 600	336	NKIS45-XL	55	1	0,5
50	68	25	45 500	82 000	14 000	8 400	4 950	270	NKI50/25-XL	55	0,6	1,5
	68	35	60 000	118 000	21 300	8 400	4 900	379	NKI50/35-XL	55	0,6	2
	72	22	53 000	80 000	13 800	7 800	4 150	274	NA4910-XL	58	0,6	1
	72	40	82 000	139 000	23 400	7 800	4 200	515	NA6910-ZW-XL	58	0,6	0,5
	80	28	71 000	98 000	17 300	7 400	4 250	518	NKIS50-XL	60	1,1	2
55	72	25	52 000	92 000	17 000	7 700	4 900	255	NKI55/25-TW-XL	60	0,6	1,5
	72	25	53 000	103 000	17 500	7 700	4 400	255	NKI55/25-TV-XL	60	0,6	1,5
	72	35	63 000	130 000	23 500	7 700	4 550	379	NKI55/35-XL	60	0,6	2
	80	25	65 000	100 000	17 300	7 200	4 000	393	NA4911-XL	63	1	1,5
	80	45	102 000	176 000	30 000	7 200	4 000	780	NA6911-ZW-XL	63	1	1,5
	85	28	75 000	108 000	19 100	6 900	4 000	558	NKIS55-XL	65	1,1	2
60	82	25	49 500	89 000	15 200	6 800	4 200	394	NKI60/25-XL	68	0,6	1
	82	35	70 000	139 000	25 500	6 800	4 050	553	NKI60/35-XL	68	0,6	1
	85	25	68 000	108 000	18 800	6 700	3 700	426	NA4912-XL	68	1	1,5
	85	45	106 000	191 000	32 500	6 700	3 700	808	NA6912-ZW-XL	68	1	1,5
	90	28	77 000	113 000	20 000	6 400	3 800	560	NKIS60-XL	70	1,1	2

medias ► <https://www.schaeffler.de/std/1E09>

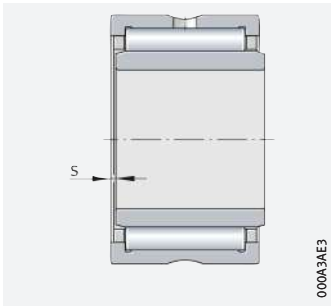

Axial displacement "s"

Main dimensions			Basic load ratings		Fatigue limit load	Limiting speed	Speed rating	Mass	Designation ▶926 1.12 ▶927 1.13 X-life ▶920	Dimensions		
d	D	B	dyn. C _r N	stat. C _{0r} N	C _{ur} N	n _G min ⁻¹	n _{Dr} min ⁻¹	m ≈ g		F	r	s
65	90	25	60 000	100 000	17 500	6 300	3 900	467	NKI65/25-XL	73	1	1
	90	35	85 000	156 000	27 000	6 300	3 750	659	NKI65/35-XL	73	1	1
	90	25	69 000	112 000	19 500	6 300	3 500	456	NA4913-XL	72	1	1,5
	90	45	108 000	198 000	33 500	6 300	3 550	833	NA6913-ZW-XL	72	1	1,5
	95	28	81 000	123 000	21 900	6 000	3 600	641	NKIS65-XL	75	1,1	2
70	95	25	63 000	119 000	19 700	5 800	3 500	521	NKI70/25-XL	80	1	0,8
	95	35	89 000	184 000	32 500	5 800	3 350	737	NKI70/35-XL	80	1	0,8
	100	30	95 000	156 000	27 500	5 700	3 250	728	NA4914-XL	80	1	1,5
	100	54	145 000	265 000	47 500	5 700	3 300	1 340	NA6914-ZW-XL	80	1	1
75	105	25	78 000	123 000	21 700	5 400	3 300	641	NKI75/25-XL	85	1	1
	105	35	111 000	193 000	34 500	5 400	3 200	908	NKI75/35-XL	85	1	1
	105	30	97 000	162 000	28 500	5 400	3 100	775	NA4915-XL	85	1	1,5
	105	54	147 000	275 000	49 500	5 400	3 150	1 450	NA6915-ZW-XL	85	1	1
80	110	25	81 000	132 000	23 300	5 100	3 150	677	NKI80/25-XL	90	1	1
	110	35	116 000	208 000	37 000	5 100	3 050	959	NKI80/35-XL	90	1	1
	110	30	101 000	174 000	30 500	5 100	2 900	878	NA4916-XL	90	1	1,5
	110	54	153 000	300 000	53 000	5 100	2 900	1 522	NA6916-ZW-XL	90	1	1
85	115	26	83 000	137 000	24 000	4 850	3 100	743	NKI85/26-XL	95	1	1,5
	115	36	121 000	223 000	39 500	4 850	2 950	1 040	NKI85/36-XL	95	1	1,5
	120	35	125 000	237 000	41 500	4 600	2 650	1 250	NA4917-XL	100	1,1	1
	120	63	188 000	400 000	71 000	4 600	2 700	2 200	NA6917-ZW-XL	100	1,1	1
90	120	26	86 000	146 000	25 000	4 600	2 950	778	NKI90/26-XL	100	1	1,5
	120	36	125 000	237 000	41 500	4 600	2 800	1 090	NKI90/36-XL	100	1	1,5
	125	35	129 000	250 000	43 500	4 400	2 500	1 312	NA4918-XL	105	1,1	1
	125	63	195 000	425 000	74 000	4 400	2 550	2 310	NA6918-ZW-XL	105	1,1	1
95	125	26	89 000	155 000	26 500	4 400	2 850	816	NKI95/26-XL	105	1	1,5
	125	36	129 000	250 000	43 500	4 400	2 700	1 145	NKI95/36-XL	105	1	1,5
	130	35	131 000	260 000	44 500	4 200	2 400	1 371	NA4919-XL	110	1,1	1
	130	63	197 000	440 000	76 000	4 200	2 440	2 500	NA6919-ZW-XL	110	1,1	1

medias ▶ <https://www.schaeffler.de/std/1E0A>





Needle roller bearings with ribs

With inner ring
Open

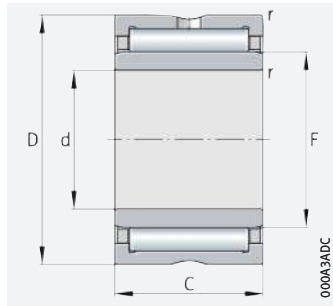

NKI, NA49, NA48

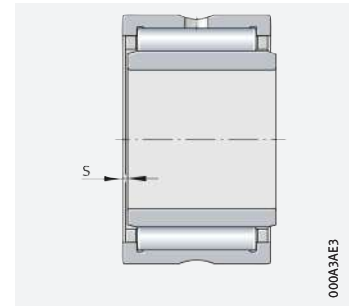

Axial displacement "s"

d = 100 – 380 mm

Main dimensions			Basic load ratings		Fatigue limit load C_{ur} N	Limiting speed n_G min^{-1}	Speed rating $n_{\partial r}$ min^{-1}	Mass m \approx g	Designation ▶ 926 1.12 ▶ 927 1.13 X-life ▶ 920	Dimensions		
d	D	B	dyn. C_r N	stat. C_{0r} N						F	r	s
100	130	30	111 000	210 000	35 500	4 200	2 650	990	NKI100/30-XL	110	1,1	1,5
	130	40	143 000	290 000	50 000	4 200	2 600	1 330	NKI100/40-XL	110	1,1	2
	140	40	144 000	270 000	45 500	4 000	2 550	1 900	NA4920-XL	115	1,1	2
110	150	40	149 000	290 000	47 500	3 700	2 330	2 070	NA4922-XL	125	1,1	2
	140	30	106 000	216 000	36 000	3 900	2 270	1 080	NA4822-XL	120	1	0,8
120	165	45	205 000	390 000	64 000	3 400	2 160	2 860	NA4924-XL	135	1,1	2
	150	30	112 000	239 000	39 000	3 600	2 070	1 170	NA4824-XL	130	1	0,8
130	180	50	229 000	470 000	74 000	3 100	2 000	3 900	NA4926-XL	150	1,5	1,5
	165	35	134 000	310 000	48 500	3 250	1 930	1 810	NA4826-XL	145	1,1	1
140	190	50	237 000	500 000	78 000	2 900	1 860	4 150	NA4928-XL	160	1,5	1,5
	175	35	136 000	325 000	50 000	3 050	1 810	1 920	NA4828-XL	155	1,1	1
150	190	40	172 000	400 000	62 000	2 850	1 780	2 720	NA4830-XL	165	1,1	1,5
160	200	40	181 000	435 000	66 000	2 700	1 650	2 890	NA4832-XL	175	1,1	1,5
170	215	45	209 000	510 000	75 000	2 550	1 610	3 960	NA4834-XL	185	1,1	1,5
180	225	45	219 000	550 000	80 000	2 420	1 490	4 200	NA4836-XL	195	1,1	1,5
190	240	50	255 000	690 000	100 000	2 250	1 330	5 610	NA4838-XL	210	1,5	1,5
200	250	50	260 000	720 000	102 000	2 150	1 250	5 840	NA4840-XL	220	1,5	1,5
220	270	50	275 000	790 000	110 000	1 980	1 110	6 380	NA4844-XL	240	1,5	1,5
240	300	60	400 000	1 080 000	150 000	1 780	960	10 000	NA4848-XL	265	2	2
260	320	60	415 000	1 160 000	158 000	1 660	870	10 600	NA4852-XL	285	2	2
280	350	69	510 000	1 300 000	175 000	1 540	840	15 300	NA4856-XL	305	2	2,5
300	380	80	700 000	1 770 000	235 000	1 420	720	21 800	NA4860-XL	330	2,1	2
320	400	80	710 000	1 850 000	242 000	1 340	670	23 000	NA4864-XL	350	2,1	2
340	420	80	730 000	1 940 000	249 000	1 270	620	24 200	NA4868-XL	370	2,1	2
360	440	80	740 000	2 020 000	255 000	1 210	590	25 600	NA4872-XL	390	2,1	2
380	480	100	1 130 000	2 900 000	370 000	1 130	510	42 600	NA4876-XL	415	2,1	2

medias ▶ <https://www.schaeffler.de/std/1E0B>





Needle roller bearings with ribs

Without inner ring
Sealed

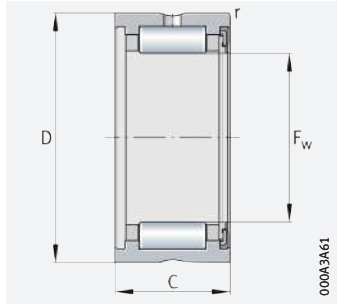

Sealed on one side (-RSR)

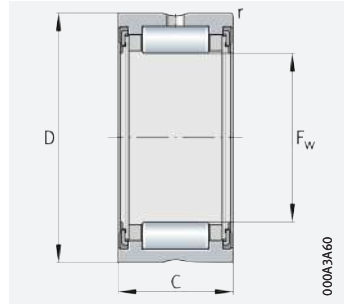

Sealed on both sides (-2RSR)

$F_w = 14 - 58 \text{ mm}$

Main dimensions			Basic load ratings		Fatigue limit load C_{ur}	Limiting speed n_G grease	Mass m	Designation		Dimensions r
F_w	D	C	dyn. C_r	stat. C_{0r}				n_G min ⁻¹	m	
14	22	13	7 700	6 900	1 360	14 800	16	RNA4900-RSR-XL	RNA4900-2RSR-XL	0,3
16	24	13	8 600	8 300	1 630	13 900	18	RNA4901-RSR-XL	RNA4901-2RSR-XL	0,3
20	28	13	9 700	10 300	2 040	12 600	21,5	RNA4902-RSR-XL	RNA4902-2RSR-XL	0,3
22	30	13	10 000	11 000	2 180	12 000	23	RNA4903-RSR-XL	RNA4903-2RSR-XL	0,3
25	37	17	19 500	19 900	3 750	10 100	56	RNA4904-RSR-XL	RNA4904-2RSR-XL	0,3
30	42	17	21 800	24 200	4 550	8 600	60	RNA4905-RSR-XL	RNA4905-2RSR-XL	0,3
35	47	17	23 900	28 500	5 400	7 500	69	RNA4906-RSR-XL	RNA4906-2RSR-XL	0,3
42	55	20	29 500	39 500	7 200	6 400	107	RNA4907-RSR-XL	RNA4907-2RSR-XL	0,6
48	62	22	41 000	53 000	8 800	5 500	154	RNA4908-RSR-XL	RNA4908-2RSR-XL	0,6
52	68	22	43 000	59 000	9 700	5 200	157	RNA4909-RSR-XL	RNA4909-2RSR-XL	0,6
58	72	22	45 000	64 000	10 600	4 650	160	RNA4910-RSR-XL	RNA4910-2RSR-XL	0,6

medias ► <https://www.schaeffler.de/std/1EOC>



Needle roller bearings with ribs

With inner ring
Sealed

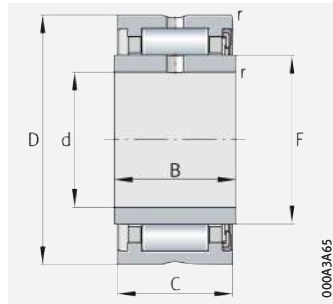

Sealed on one side (-RSR)

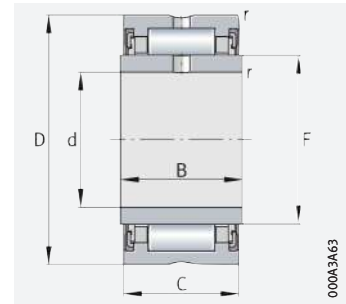

Sealed on both sides (-2RSR)

d = 10 – 50 mm

Main dimensions			Basic load ratings		Fatigue limit load C_{ur}	Limiting speed n_G grease	Mass m	Designation		Dimensions		
d	D	B	dyn. C_r	stat. C_{0r}						F	C	r
			N	N	N	min^{-1}	\approx g				min.	
10	22	14	7 700	6 900	1 360	14 800	24,5	NA4900-RSR-XL	NA4900-2RSR-XL	14	13	0,3
12	24	14	8 600	8 300	1 630	13 900	27,5	NA4901-RSR-XL	NA4901-2RSR-XL	16	13	0,3
15	28	14	9 700	10 300	2 040	12 600	37	NA4902-RSR-XL	NA4902-2RSR-XL	20	13	0,3
17	30	14	10 000	11 000	2 180	12 000	40	NA4903-RSR-XL	NA4903-2RSR-XL	22	13	0,3
20	37	18	19 500	19 900	3 750	10 100	80	NA4904-RSR-XL	NA4904-2RSR-XL	25	17	0,3
25	42	18	21 800	24 200	4 550	8 600	89,5	NA4905-RSR-XL	NA4905-2RSR-XL	30	17	0,3
30	47	18	23 900	28 500	5 400	7 500	104	NA4906-RSR-XL	NA4906-2RSR-XL	35	17	0,3
35	55	21	29 500	39 500	7 200	6 400	175	NA4907-RSR-XL	NA4907-2RSR-XL	42	20	0,6
40	62	23	41 000	53 000	8 800	5 500	252	NA4908-RSR-XL	NA4908-2RSR-XL	48	22	0,6
45	68	23	43 000	59 000	9 700	5 200	290	NA4909-RSR-XL	NA4909-2RSR-XL	52	22	0,6
50	72	23	45 000	64 000	10 600	4 650	295	NA4910-RSR-XL	NA4910-2RSR-XL	58	22	0,6

medias ► <https://www.schaeffler.de/std/1E0D>





Needle roller bearings without ribs

Without inner ring
Open

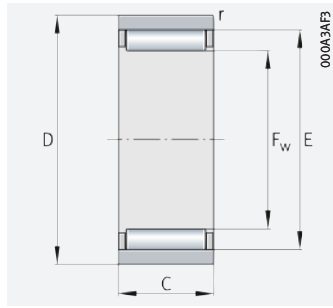

RNAO

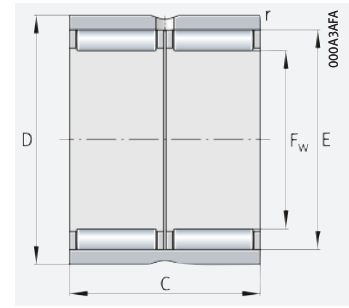

RNAO..-ZW-ASR1

F_w = 5 – 35 mm

Main dimensions			Basic load ratings		Fatigue limit load	Limiting speed	Speed rating	Mass	Designation
F _w	D	C	dyn. C _r	stat. C _{0r}	C _{ur}	n _G	n _{Dr}	m	
			N	N	N	min ⁻¹	min ⁻¹	≈ g	
5	10	8	2 650	1 920	295	39 000	53 000	3	RNA05×10×8-TV-XL
6	13	8	2 950	2 280	355	36 500	48 500	6	RNA06×13×8-TV-XL
7	14	8	3 250	2 650	410	34 500	41 500	6	RNA07×14×8-TV-XL
8	15	10	4 450	4 100	690	32 500	35 500	8	RNA08×15×10-TV-XL
10	17	10	5 300	5 500	930	29 500	28 000	10	RNA010×17×10-TV-XL
12	22	12	11 300	9 900	1 740	26 000	19 700	19	RNA012×22×12-TV-XL
15	23	13	9 700	10 900	1 760	24 300	17 900	20	RNA015×23×13-XL
16	24	13	10 100	11 800	1 890	23 600	16 800	21	RNA016×24×13-XL
	28	12	13 000	12 500	2 210	22 900	15 900	32	RNA016×28×12-XL
17	25	13	11 700	14 600	2 240	22 900	15 200	22	RNA017×25×13-XL
18	30	24	24 800	30 000	5 300	21 800	14 000	69	RNA018×30×24-ZW-ASR1-XL
20	28	13	11 100	14 300	2 310	21 300	13 700	25	RNA020×28×13-XL
	28	26	19 000	28 500	4 600	21 300	13 700	50	RNA020×28×26-ZW-ASR1-XL
	32	12	15 100	16 200	2 850	20 900	12 700	38	RNA020×32×12-XL
22	30	13	11 800	15 900	2 550	20 400	12 400	27	RNA022×30×13-XL
	35	16	22 600	25 500	4 200	19 200	11 200	59	RNA022×35×16-XL
25	35	17	16 800	26 000	4 250	18 100	11 000	53	RNA025×35×17-XL
	35	26	21 900	37 000	5 900	18 100	11 200	76	RNA025×35×26-ZW-ASR1-XL
	37	16	23 500	27 500	4 550	17 200	10 000	60	RNA025×37×16-XL
30	40	17	22 100	34 000	5 300	15 100	8 800	60	RNA030×40×17-XL
	42	16	26 000	33 500	5 500	14 600	8 500	59	RNA030×42×16-XL
	42	32	45 000	67 000	11 000	14 600	8 500	137	RNA030×42×32-ZW-ASR1-XL
35	45	13	18 300	28 000	4 450	13 100	7 800	53	RNA035×45×13-XL
	45	17	23 500	38 500	6 100	13 100	7 700	69	RNA035×45×17-XL
	45	26	31 500	56 000	8 900	13 100	7 800	91	RNA035×45×26-ZW-ASR1-XL
	47	16	27 500	37 500	6 200	12 700	7 500	78	RNA035×47×16-XL
	47	18	31 000	43 000	7 400	12 700	7 400	89	RNA035×47×18-XL
	47	32	47 500	75 000	12 400	12 700	7 500	156	RNA035×47×32-ZW-ASR1-XL

medias ► <https://www.schaeffler.de/std/1E0E>

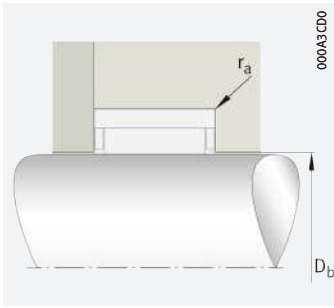

Axial guidance of needle roller and cage assembly in housing

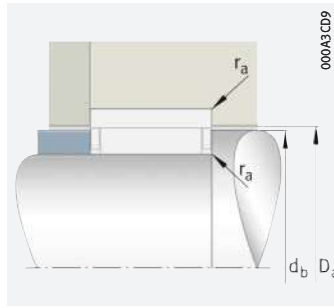

Axial guidance of needle roller and cage assembly on shaft

Dimensions			Mounting dimensions			
F_w	E	r min.	D_b	d_b	D_a	r_a max.
5	8	0,15	5,3	7,7	8,3	0,1
6	9	0,3	6,3	8,7	9,3	0,3
7	10	0,3	7,3	9,7	10,3	0,3
8	11	0,3	8,3	10,7	11,3	0,3
10	13	0,3	10,3	12,7	13,3	0,3
12	18	0,3	12,3	17,6	18,3	0,3
15	19	0,3	15,4	18,6	19,3	0,3
16	20	0,3	16,4	19,6	20,3	0,3
	22	0,3	16,4	21,6	22,3	0,3
17	21	0,3	17,4	20,6	21,3	0,3
18	24	0,3	18,4	23,6	24,5	0,3
20	24	0,3	20,4	23,6	24,3	0,3
	24	0,3	20,4	23,6	24,3	0,3
	26	0,3	20,4	25,6	26,5	0,3
22	26	0,3	22,4	25,6	26,3	0,3
	29	0,3	22,4	28,4	29,5	0,3
25	29	0,3	25,6	28,4	29,5	0,3
	29	0,3	25,6	28,4	29,5	0,3
	32	0,3	25,6	31,4	32,5	0,3
30	35	0,3	30,6	34,4	35,5	0,3
	37	0,3	30,6	36,4	37,5	0,3
	37	0,3	30,6	36,4	37,5	0,3
35	40	0,3	35,6	39,4	40,5	0,3
	40	0,3	35,6	39,4	40,5	0,3
	40	0,3	35,6	39,4	40,5	0,3
	42	0,3	35,6	41,4	42,5	0,3
	42	0,3	35,6	41,4	42,5	0,3
	42	0,3	35,6	41,4	42,5	0,3





Needle roller bearings without ribs

Without inner ring
Open

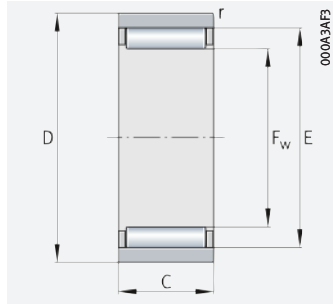

RNAO

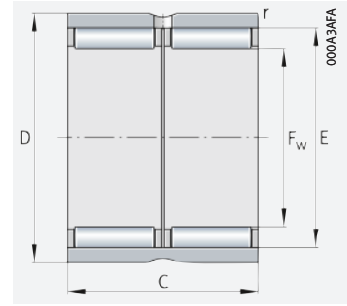

RNAO..-ZW-ASR1

F_w = 40 – 100 mm

Main dimensions			Basic load ratings		Fatigue limit load	Limiting speed	Speed rating	Mass	Designation
F _w	D	C	dyn. C _r	stat. C _{0r}	C _{ur}	n _G	n _{θr}	m	
			N	N	N	min ⁻¹	min ⁻¹	≈ g	
40	50	17	24 200	41 500	6 400	11 500	7 000	74	RNAO40×50×17-XL
	50	34	41 500	83 000	12 900	11 500	7 000	152	RNAO40×50×34-ZW-ASR1-XL
	55	20	37 000	57 000	8 900	11 300	6 600	145	RNAO40×55×20-XL
	55	40	70 000	118 000	18 700	11 100	6 500	275	RNAO40×55×40-ZW-ASR1-XL
45	55	17	25 500	46 000	7 100	10 300	6 300	83	RNAO45×55×17-XL
	62	40	76 000	135 000	21 500	10 000	5 900	377	RNAO45×62×40-ZW-ASR1-XL
50	62	20	30 000	60 000	9 600	9 300	5 800	140	RNAO50×62×20-XL
	65	20	40 500	62 000	10 800	9 100	5 600	168	RNAO50×65×20-XL
	65	40	69 000	124 000	21 700	9 100	5 600	355	RNAO50×65×40-ZW-ASR1-XL
55	68	20	32 000	66 000	10 700	8 500	5 400	166	RNAO55×68×20-XL
60	78	20	49 500	85 000	13 600	7 700	4 650	255	RNAO60×78×20-XL
	78	40	85 000	171 000	27 500	7 700	4 650	435	RNAO60×78×40-ZW-ASR1-XL
65	85	30	64 000	123 000	21 100	7 100	4 550	464	RNAO65×85×30-XL
70	90	30	68 000	135 000	23 200	6 600	4 250	499	RNAO70×90×30-XL
80	100	30	80 000	176 000	31 000	5 800	3 600	580	RNAO80×100×30-XL
	105	26	69 000	150 000	25 000	5 200	3 350	373	RNAO90×105×26-XL
90	110	30	76 000	172 000	29 500	5 200	3 450	610	RNAO90×110×30-XL
	120	30	80 000	188 000	32 000	4 700	3 150	694	RNAO100×120×30-XL

medias ► <https://www.schaeffler.de/std/1E0F>

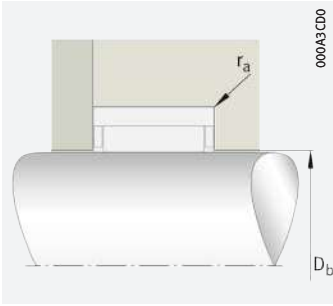

Axial guidance of needle roller and cage assembly in housing

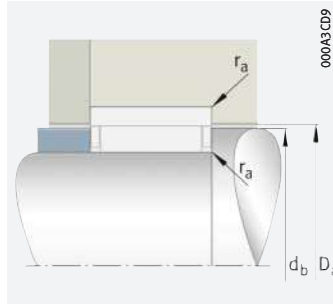

Axial guidance of needle roller and cage assembly on shaft

Dimensions			Mounting dimensions			
F_w	E	r min.	D_b	d_b	D_a	r_a max.
40	45	0,3	40,6	44,4	45,5	0,3
	45	0,3	40,6	44,4	45,5	0,3
	47	0,3	40,6	46,2	47,5	0,3
	48	0,3	40,6	47,2	47,5	0,3
45	50	0,3	45,6	49,2	50,5	0,3
	53	0,3	45,6	52,2	53,5	0,3
50	55	0,3	50,6	54,2	55,8	0,3
	58	0,3	50,6	57,2	58,5	0,3
	58	0,6	50,6	57,2	58,5	0,6
55	60	0,6	55,8	59,4	60,8	0,6
60	68	1	60,8	67,2	68,8	1
	68	1	60,8	67,2	68,8	1
65	73	1	66	72,2	73,8	1
70	78	1	71	77,2	78,8	1
80	88	1	81	87,2	89	1
90	98	1	91	97,2	99	1
	98	1	91	97,2	99	1
100	108	1	101	107,2	109	1





Needle roller bearings without ribs

With inner ring
Open

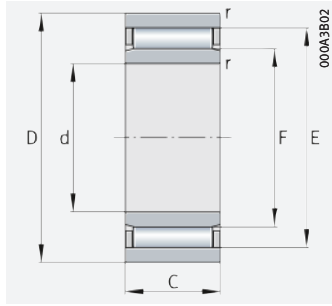

NAO, NAO..-IS1
(with lubrication hole in inner ring)

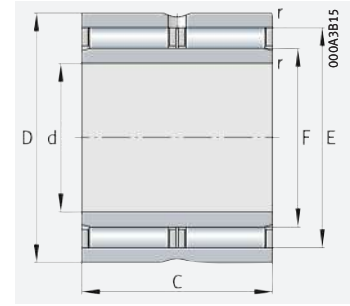

NAO..-ZW-ASR1

d = 6 – 90 mm

Main dimensions			Basic load ratings		Fatigue limit load C_{ur}	Limiting speed n_G	Speed rating $n_{\theta r}$	Mass m	Designation
d	D	B	dyn. C_r	stat. C_{0r}					
			N	N	N	min ⁻¹	min ⁻¹	≈ g	
6	17	10	5 300	5 500	930	29 500	23 800	14	NAO6×17×10-TV-IS1-XL
9	22	12	11 300	9 900	1 740	26 000	17 900	23,5	NAO9×22×12-TV-XL
12	24	13	10 100	11 800	1 890	23 600	15 000	30	NAO12×24×13-XL
	28	12	13 000	12 500	2 210	22 900	14 300	40	NAO12×28×12-IS1-XL
15	28	13	11 100	14 300	2 310	21 300	12 100	29	NAO15×28×13-XL
	32	12	15 100	16 200	2 850	20 900	11 400	50	NAO15×32×12-IS1-XL
17	30	13	11 800	15 900	2 550	20 400	11 100	42	NAO17×30×13-XL
	35	16	22 600	25 500	4 200	19 200	10 100	78	NAO17×35×16-XL
20	35	17	16 800	26 000	4 250	18 100	10 000	76	NAO20×35×17-XL
	37	16	23 500	27 500	4 550	17 200	9 100	82	NAO20×37×16-XL
25	40	17	22 100	34 000	5 300	15 100	8 100	88	NAO25×40×17-XL
	42	16	26 000	33 500	5 500	14 600	7 800	86	NAO25×42×16-IS1-XL
	42	32	45 000	67 000	11 000	14 600	7 800	190	NAO25×42×32-ZW-ASR1-XL
30	45	17	23 500	38 500	6 100	13 100	7 100	102	NAO30×45×17-XL
	45	26	31 500	56 000	8 900	13 100	7 200	157	NAO30×45×26-ZW-ASR1-XL
	47	16	27 500	37 500	6 200	12 700	6 900	109	NAO30×47×16-XL
	47	18	31 000	43 000	7 400	12 700	6 900	119	NAO30×47×18-XL
35	50	17	24 200	41 500	6 400	11 500	6 500	113	NAO35×50×17-XL
	55	20	37 000	57 000	8 900	11 300	6 200	190	NAO35×55×20-XL
40	55	17	25 500	46 000	7 100	10 300	5 900	127	NAO40×55×17-XL
50	68	20	32 000	66 000	10 700	8 500	5 100	230	NAO50×68×20-IS1-XL
70	100	30	80 000	176 000	31 000	5 800	3 350	850	NAO70×100×30-XL
80	110	30	76 000	172 000	29 500	5 200	3 200	920	NAO80×110×30-XL
90	120	30	80 000	188 000	32 000	4 700	2 950	1 044	NAO90×120×30-XL

medias ► <https://www.schaeffler.de/std/1E10>

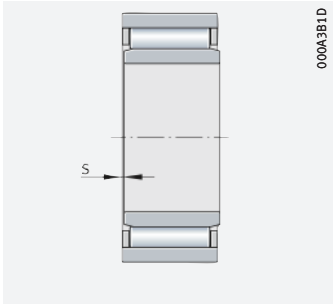

Axial displacement "s"

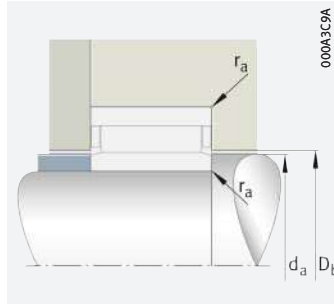

Axial guidance of needle roller and cage assembly in housing

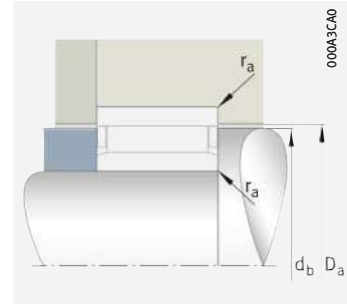

Axial guidance of needle roller and cage assembly on shaft

Dimensions					Mounting dimensions				
d	F	E	r	s	d _a	D _b	d _b	D _a	r _a
			min.						max.
6	10	13	0,3	0,5	9,7	10,3	12,7	13,3	0,3
9	12	18	0,3	0,5	11,7	12,3	17,6	18,3	0,3
12	16	20	0,3	0,5	15,7	16,4	19,6	20,3	0,3
	16	22	0,3	0,5	15,7	16,4	21,6	22,3	0,3
15	20	24	0,3	0,5	19,7	20,4	23,6	24,3	0,3
	20	26	0,3	0,5	19,7	20,4	25,6	26,5	0,3
17	22	26	0,3	0,5	21,5	22,4	25,6	26,3	0,3
	22	29	0,3	0,5	21,5	22,4	28,4	29,5	0,3
20	25	29	0,3	0,5	24,5	25,6	28,4	29,5	0,3
	25	32	0,3	0,5	24,5	25,6	31,4	32,5	0,3
25	30	35	0,3	0,8	29,5	30,6	34,4	35,5	0,3
	30	37	0,3	0,8	29,5	30,6	36,4	37,5	0,3
	30	37	0,3	0,8	29,5	30,6	36,4	37,5	0,3
30	35	40	0,3	0,8	34,5	35,6	39,4	40,5	0,3
	35	40	0,3	0,8	34,5	35,6	39,4	40,5	0,3
	35	42	0,3	0,8	34,5	35,6	41,4	42,5	0,3
	35	42	0,3	0,8	34,5	35,6	41,4	42,5	0,3
35	40	45	0,3	0,8	39,5	40,6	44,4	45,5	0,3
	40	47	0,3	0,8	39,5	40,6	46,2	47,5	0,3
40	45	50	0,3	0,8	44,5	45,6	49,2	50,5	0,3
50	55	60	0,6	1	54,5	55,8	59,2	60,8	0,6
70	80	88	1	1	79,3	81	87,2	89	1
80	90	98	1	1	89,3	91	97,2	99	1
90	100	108	1	1	99,3	101	107,2	109	1





Aligning needle roller bearings

Without inner ring

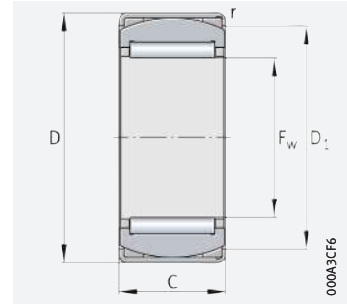

RPNA

F_w = 15 – 45 mm

Main dimensions			Basic load ratings		Fatigue limit load C _{ur} N	Limiting speed n _G min ⁻¹	Mass m ≈ g	Designation ➤ 926 1.12 ➤ 927 1.13 X-life ➤ 920	Dimensions	
F _w	D	C	dyn. C _r N	stat. C _{0r} N					D ₁	r
		±0,5								min.
15	28	12	7 800	7 900	1 430	24 100	32	RPNA15/28-XL	24,5	0,8
18	32	16	14 100	16 200	3 000	22 100	52	RPNA18/32-XL	27	0,8
20	35	16	14 600	17 500	3 200	21 100	62	RPNA20/35-XL	30,5	0,8
25	42	20	21 300	30 500	5 300	17 800	109	RPNA25/42-XL	36,5	0,8
28	44	20	24 800	34 000	5 900	15 800	112	RPNA28/44-XL	38,5	0,8
30	47	20	25 500	36 000	6 300	14 800	125	RPNA30/47-XL	42	0,8
35	52	20	27 500	41 500	7 300	12 900	131	RPNA35/52-XL	47,5	0,8
40	55	20	29 500	47 000	8 300	11 400	141	RPNA40/55-XL	50,5	0,8
45	62	20	31 000	53 000	9 300	10 200	176	RPNA45/62-XL	58	0,8

medias ➤ <https://www.schaeffler.de/std/1E11>



Aligning needle roller bearings

With inner ring

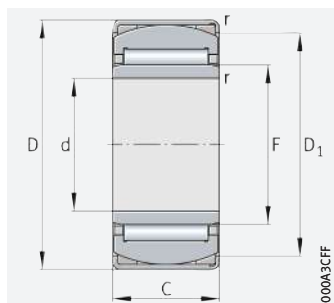

PNA

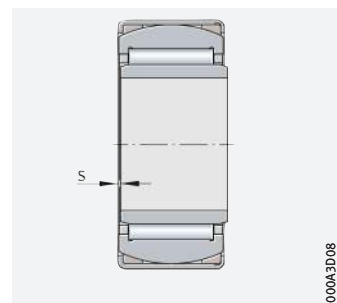

Axial displacement "s"

d = 12 – 40 mm

Main dimensions			Basic load ratings		Fatigue limit load C_{ur}	Limiting speed n_G	Mass m	Designation	Dimensions					
d	D	C	dyn. C_r	stat. C_{0r}					F	B	D_1	r	r_1	s
		$\pm 0,5$	N	N	N	min^{-1}	$\approx \text{g}$	▶ 926 1.12 ▶ 927 1.13 X-life ▶ 920				min.	min.	min.
12	28	12	7 800	7 900	1 430	24 100	37	PNA12/28-XL	15	12	24,5	0,8	0,3	0,5
15	32	16	14 100	16 200	3 000	22 100	62	PNA15/32-XL	18	16	27	0,8	0,3	0,5
17	35	16	14 600	17 500	3 200	21 100	73	PNA17/35-XL	20	16	30,5	0,8	0,3	0,5
20	42	20	21 300	30 500	5 300	17 800	136	PNA20/42-XL	25	20	36,5	0,8	0,3	0,5
22	44	20	24 800	34 000	5 900	15 800	145	PNA22/44-XL	28	20	38,5	0,8	0,3	0,5
25	47	20	25 500	36 000	6 300	14 800	157	PNA25/47-XL	30	20	42	0,8	0,3	0,5
30	52	20	27 500	41 500	7 300	12 900	181	PNA30/52-XL	35	20	47,5	0,8	0,3	0,5
35	55	20	29 500	47 000	8 300	11 400	177	PNA35/55-XL	40	20	50,5	0,8	0,3	0,5
40	62	20	31 000	53 000	9 300	10 200	227	PNA40/62-XL	45	20	58	0,8	0,3	0,5

medias ▶ <https://www.schaeffler.de/std/1E12>



2 Combined needle roller bearings



The bearings:

- can support high radial loads and moderate axial loads by means of a single bearing position ▶964|ⓐ1
- are suitable for applications with a very small radial design envelope, where the raceway on the shaft is designed as a rolling bearing raceway (direct bearing arrangement)
- permit relatively high speeds, if the rolling element set in the axial bearing component is not full complement but guided by a cage
- have a high running accuracy
- permit locating bearing arrangements with only a very small radial design envelope
- result in axially rigid bearing arrangements
- are easy to mount as they are not self-retaining in many cases
- permit technically straightforward, economical and cost-effective designs.

For an overview of other product-specific features, see the Matrix for bearing preselection ▶912.

1
Combined needle roller bearing /
needle roller bearing:
comparison of load direction

F_r = radial load

F_a = axial load

- ① Needle roller/axial deep groove ball bearing NKX
- ② Needle roller bearing NK

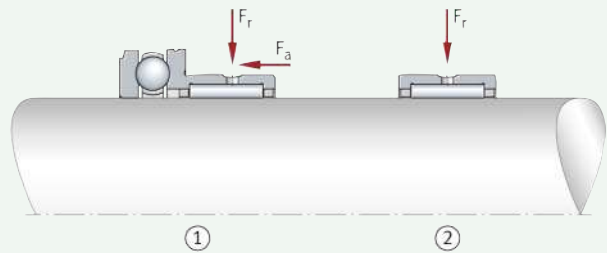

2.1 Bearing design

Design variants

The standard product range of combined needle roller bearings comprises:

- needle roller/axial deep groove ball bearings
▶965|ⓐ3 to ▶966|ⓐ5
- needle roller/axial cylindrical roller bearings
▶967|ⓐ6 and ▶967|ⓐ7
- needle roller/angular contact ball bearings
▶967|ⓐ8 and ▶968|ⓐ9.

The majority of these needle roller bearings are X-life bearings ▶968.

The bearings comprise a radial component and an axial component

Combined needle roller bearings

Combined needle roller bearings comprise a radial needle roller bearing, which is combined with an axial bearing component ➤965|☐3, ➤966|☐5 and ➤967|☐6. These bearings can support radial as well as axial loads with just one bearing and permit locating bearing arrangements with only a small radial design envelope ➤965|☐2 and ➤968|2.2. They are suitable, for example, where radial and axial loads are present and simple axial contact washers are no longer able to support the axial loads on account of their size, high speeds or inadequate lubrication, and other locating bearings require too much installation space.



Combined needle roller bearings, radial and axial dynamic load carrying capacity

C_r = radial basic dynamic load rating

C_a = basic axial dynamic load rating

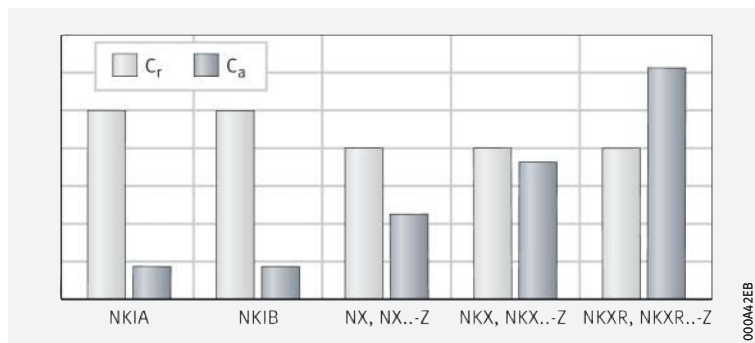

000A4ZEB

Suitable for compact direct bearing arrangements on the shaft

Needle roller/axial deep groove ball bearings

Needle roller/axial deep groove ball bearings do not have an inner ring and are therefore particularly compact in a radial direction ➤965|☐3. However, they require a shaft raceway that is hardened and ground ➤977|2.16. If the shaft cannot be used as a rolling bearing raceway, inner rings IR can be used instead ➤966|☐4. The suitable inner rings are given in the product tables and must be ordered in addition to the bearing ➤984|☐. For lubrication, the outer ring of the radial bearing component has a lubrication groove and lubrication holes.

Type NX, NX...-Z

Needle roller/axial deep groove ball bearings NX and NX...-Z have a full complement ball rolling element set and an extremely low radial section height ➤965|☐3. Due to the compact radial dimensions, bearing arrangements can be achieved with very small shaft centre distances, such as those that may be present in multi-spindle drilling machines. A sheet steel end cap secured to the radial bearing component grips the shaft locating washing of the axial bearing and holds the axial bearing component together ➤965|☐3. As a result, the bearings are self-retaining. The sheet metal caps for bearings NX have lubrication holes for oil lubrication ➤965|☐3 and ➤971|2.4.

The rolling element set for the axial bearing component is a full complement ball system



Needle roller/axial deep groove ball bearing NX without inner ring

F_r = radial load

F_a = axial load

- ① NX, full complement axial ball bearing component, with end cap, lubrication holes in the cap
- ② NX...-Z, full complement axial ball bearing component, with end cap, no lubrication holes in the cap
- ③ End cap

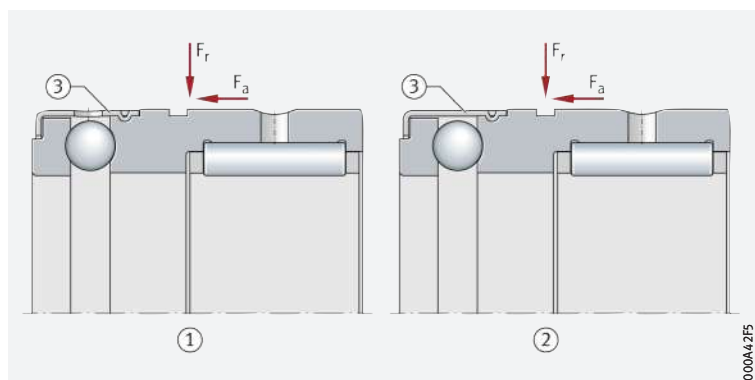

000A4ZES



Needle roller/axial deep groove ball bearing NX...-Z with inner ring

- ① Inner ring IR

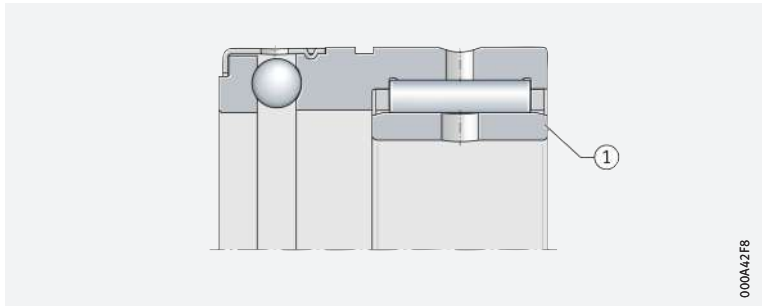

Type NKX, NKX...-Z

☞ *The rolling element set for the axial bearing component is guided by a cage*

In bearings NKX and NKX...-Z, the rolling element set is not a full complement ball system, as is present in bearings NX, but is retained by a cage ▶966|⑤. The ball and cage assembly corresponds to an axial deep groove ball bearing of series 511. As a result of the cage, these bearings are suitable for higher speeds than bearings of the full complement design ▶984|⑥.

☞ *Type NKX*

Bearings NKX are not self-retaining, i.e. radial needle roller bearing, axial ball and cage assembly and shaft locating washer can be fitted independently of each other ▶966|⑤.

☞ *Type NKX...-Z*

Type NKX...-Z has a sheet steel end cap, which holds the axial bearing component together, i.e. the bearings are self-retaining. The cap is designed without lubrication holes and is rigidly connected to the housing locating washer of the radial bearing component ▶966|⑤.



Needle roller/axial deep groove ball bearings without inner ring

F_r = radial load
 F_a = axial load

- ① NKX, axial bearing component with ball and cage assembly, without end cap
- ② NKX...-Z, axial bearing component with ball and cage assembly, with end cap, no lubrication holes in the cap
- ③ End cap

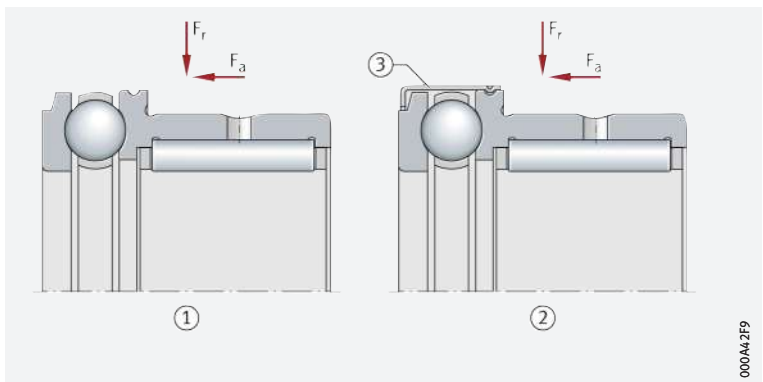

Needle roller/axial cylindrical roller bearings

Type NKXR, NKXR...-Z

☞ *The rolling element set for the axial bearing component is guided by a cage*

These bearings comprise a radial needle roller bearing and an axial cylindrical roller bearing of series 811 with a plastic cage. They do not have an inner ring and require a shaft raceway that is hardened and ground ▶967|⑥ and ▶977|2.16. If the shaft cannot be used as a rolling bearing raceway, inner rings IR can be used instead ▶967|⑦. The suitable inner rings are given in the product tables and must be ordered in addition to the bearing ▶988|⑥. For lubrication, the outer ring of the radial bearing component has a lubrication groove and lubrication holes.

☞ *Type NKXR*

Type NKXR is not self-retaining, i.e. the radial needle roller bearing, axial cylindrical roller bearing and shaft locating washer can be fitted independently of each other ▶967|⑥.

☞ *Type NKXR...-Z*

A sheet steel end cap secured to the radial bearing component grips the shaft locating washing of the axial cylindrical roller bearing and holds the axial bearing component together. As a result, these bearings are self-retaining ▶967|⑥.

6

Needle roller/axial cylindrical roller bearings without inner ring

F_r = radial load
 F_a = axial load

- ① NKXR, axial bearing component with roller and cage assembly, without end cap
- ② NKXR..-Z, axial bearing component with roller and cage assembly, with end cap, no lubrication holes in the cap
- ③ End cap

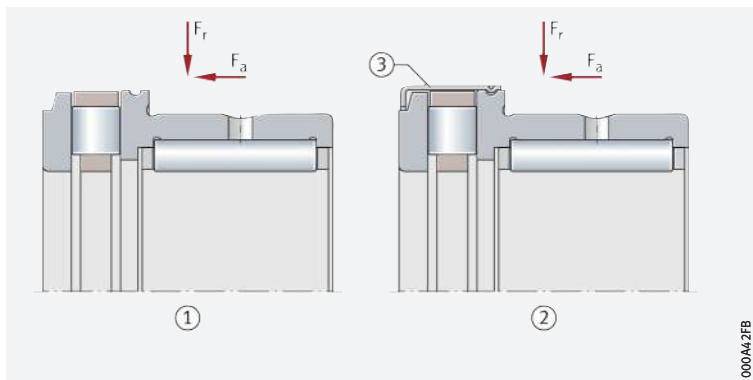

7

Needle roller/axial cylindrical roller bearing NKXR with inner ring

- ① Inner ring IR

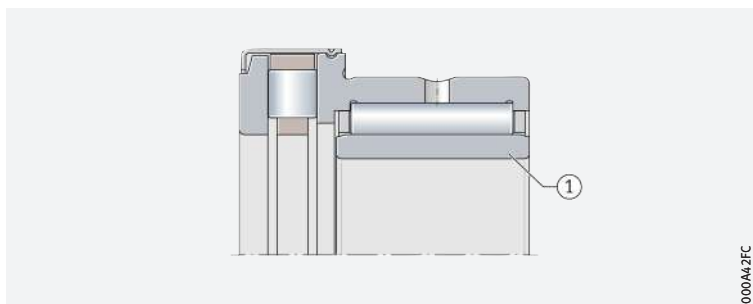

Needle roller/angular contact ball bearings

Type NKIA, NKIB

The rolling element set for the axial bearing component is guided by a cage

Needle roller/angular contact ball bearings comprise a radial needle roller bearing, an angular contact ball bearing as the axial component and an inner ring ▶967| 8 and ▶968| 9. In the case of type NKIA the inner ring is of a single-piece design, whereas design NKIB has one narrow and one wide inner ring. The ball cage of the axial bearing component is made from plastic ▶967| 8 and ▶968| 9 and ▶973| 2.9. The bearings have a low radial section height and are suitable for high speeds ▶990| 1. As needle roller/angular contact ball bearings are not self-retaining, the inner ring can be mounted independently of the outer ring and needle roller and ball set. During fitting it must, however, be ensured that the bearing rings are not interchanged with rings from other bearings, but are always mounted in the delivered matched pair.

8

Needle roller/angular contact ball bearing NKIA

F_r = radial load
 F_a = axial load

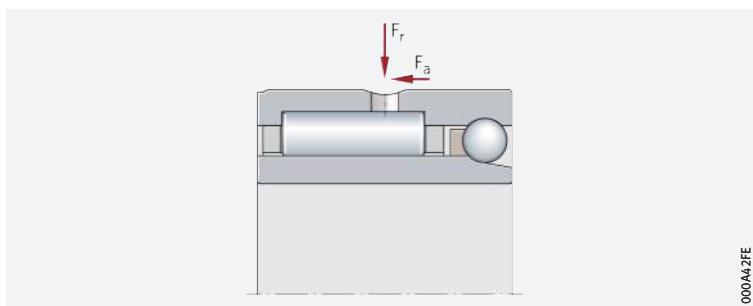



Needle roller/angular contact ball bearing NKIB

F_r = radial load
 F_a = axial load

- ① Wide inner ring
- ② Narrow inner ring

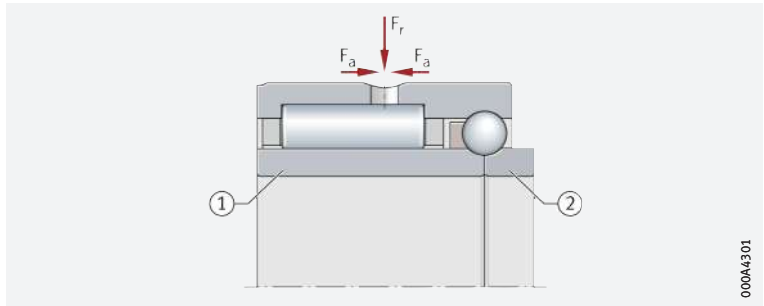

X-life

X-life premium quality

The combined needle roller bearings described here are X-life bearings. They are characterised by a very high load carrying capacity and long rating life. This is achieved, for example, through the modified internal construction and optimised contact geometry between the rolling elements and raceways, as well as through the higher quality of the steel and rolling elements, higher surface quality and appropriate heat treatment.

☞ *Increased customer benefits due to X-life*

Advantages

The technical enhancements offer a range of advantages, such as:

- a more favourable load distribution in the bearing and thus a higher dynamic load carrying capacity of the bearings
- quieter running
- running with reduced friction and greater energy efficiency
- lower heat generation in the bearing
- higher possible speeds
- lower lubricant consumption and, consequently, longer maintenance intervals
- a measurably longer operating life of the bearings
- high operational security
- compact, environmentally-friendly bearing arrangements.

☞ *Lower operating costs, higher machine availability*

In conclusion, these advantages improve the overall cost-efficiency of the bearing position significantly and thus bring about a sustainable increase in the efficiency of the machine and equipment.

☞ *Suffix XL*

Combined needle roller bearings in X-life quality include the suffix XL in the designation ►972|📏 13 to ►975|📏 15 and ►984|📏.



X-life indicates a high product performance density and thus a particularly significant benefit to the customer. Further information on X-life ►10.

2.2 Load carrying capacity

☞ *Suitable for moderate axial loads*

Needle roller/axial deep groove ball bearings NX, NX..-Z, NKX, NKX..-Z

Needle roller/axial deep groove ball bearings support high radial loads and moderate axial loads in one direction ►965|📏 3 to ►966|📏 5. Bearings with a full complement ball set have a higher axial load carrying capacity than bearings with a cage-guided axial component ►965|📏 2.

☞ *Mounting of two needle roller/axial deep groove ball bearings in a mirror image arrangement*

Bearing arrangement for supporting axial loads in both directions

Needle roller/axial deep groove ball bearings can support axial loads in one direction only. If no temperature-induced changes in length occur during operation in an arrangement of short shafts, two bearings can also be used to support axial loads in both directions, which are then mounted in a mirror image arrangement ►969|📏 10. The bearing parts should, however, be elastically preloaded in an axial direction, for example by means of disc springs ►969|📏 10. The elastic preload ensures that the unloaded axial bearing component runs without slippage ►977|2.15. The preload also improves the operating behaviour of axial ball bearings and reduces running noise.

10

Two needle roller/axial deep groove ball bearings NKX mounted in a mirror image arrangement and axially preloaded with disc springs

- ① Needle roller/axial deep groove ball bearing NKX
- ② Disc spring set
- ③ Shaft nut for preloading

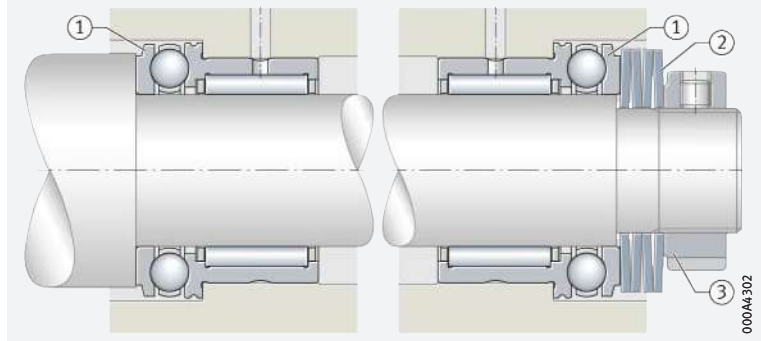

Suitable for high axial loads

Mounting of two needle roller/axial cylindrical roller bearings in a mirror image arrangement

NKIA for axial forces in one direction, NKIB for alternating axial forces

Mounting of two needle roller/angular contact ball bearings in a mirror image arrangement

Needle roller/axial cylindrical roller bearings NKXR, NKXR..-Z

Needle roller/axial cylindrical roller bearings support high radial loads and also, due to the line contact of the cylindrical rollers, high axial loads in one direction ▶965|☐2, ▶967|☐8 and ▶968|☐9.

Bearing arrangement for supporting axial loads in both directions

Needle roller/axial cylindrical roller bearings can support axial loads in one direction only. If no temperature-induced changes in length occur during operation in an arrangement of short shafts, two bearings can also be used to support axial loads in both directions, which are then mounted in a mirror image arrangement. The bearing parts should, however, be elastically preloaded in an axial direction, for example by means of disc springs ▶969|☐10. The elastic preload ensures that the unloaded axial bearing component runs without slippage. The preload also improves the operating behaviour of needle roller/axial cylindrical roller bearings and reduces running noise.

Needle roller/angular contact ball bearings NKIA, NKIB

The radial bearing supports high radial loads, the angular contact ball bearing supports smaller axial forces. NKIA can support axial loads from one direction only ▶967|☐8. NKIB has one narrow and one wide inner ring ▶968|☐9. At the point where the inner rings join, there is a shoulder on both sides for guidance of the ball and cage assembly. As a result, these bearings are also suitable for supporting axial forces alternating in direction, i. e. as locating bearings, they can guide the shaft axially in both directions. The shaft is guided axially with an axial clearance of 0,08 mm to 0,25 mm.

Replacement of inner rings

In standard bearings of series NKIA and NKIB, the inner rings are matched to the enveloping circle tolerance F6 and can be interchanged with each other (mixed use) within the same accuracy class.



When mounting bearings NKIB, both inner ring parts must be located axially clearance-free against each other. The narrow inner ring has a larger bore diameter. This results in an interference fit if a shaft tolerance k6 is used.

Bearing arrangement for supporting axial loads in both directions with bearings NKIA

Needle roller/angular contact ball bearings NKIA support axial loads in one direction. In order to support axial loads in both directions, two bearings NKIA can also be used, which are then mounted in a mirror image arrangement ▶970|☐11.



11

Two needle roller/angular contact ball bearings NKIA mounted in a mirror image arrangement

- ① Needle roller/angular contact ball bearing NKIA
- ② Shaft nut for preloading

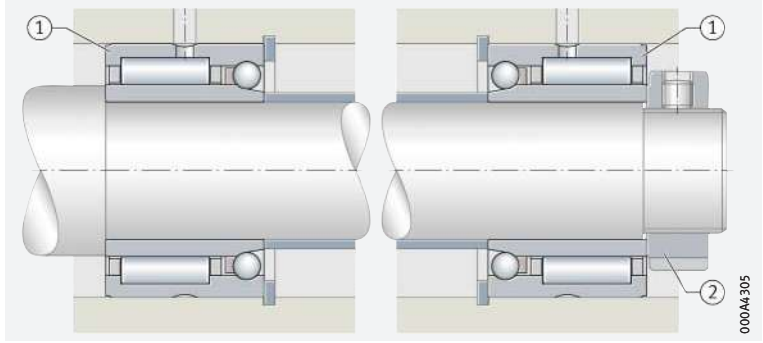

000A4305

Preloading of the axial bearing component

Shortening of the retaining rings where there is little distance between the shafts

Support of axial forces

The axial bearing component must be preloaded to 1% of the axial basic static load rating C_{0a} (for example using disc springs). The basic load ratings C_{0a} are stated in the product tables.

Needle roller/axial deep groove ball bearings and needle roller/axial cylindrical roller bearings

In order to support axial forces, the bearings must be abutted by means of snap rings on the outer ring or a housing shoulder. If there is little distance between the shaft centres, the snap rings should be shortened
 ▶ 970 | 12. Snap rings WR and SW are available from trade outlets. If the bearings are to support axial forces from alternating directions, two bearings must be fitted opposed to each other. The unloaded bearing must then be axially preloaded, for example by means of disc springs
 ▶ 969 | 10. This allows compensation of thermal expansion.

12

Bearing arrangement with shortened snap rings

- ① Snap ring
- ② Shortened area

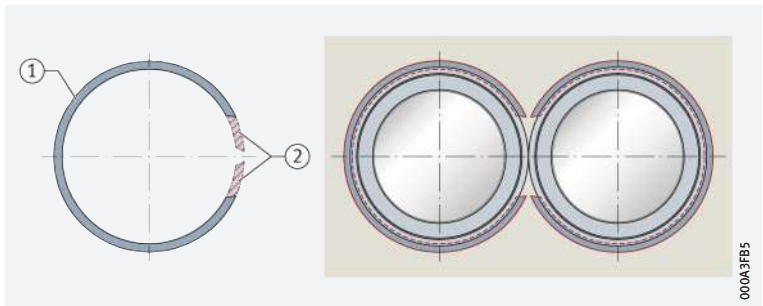

000A3FB5

Shaft raceway designed in accordance with DIN 617

! If the surface of the shaft raceway is produced to DIN 617, the basic load ratings C_r in the product tables must be reduced by 15%.

2.3 Compensation of angular misalignments

The bearings are not suitable for the compensation of shaft misalignments relative to the housing

Combined needle roller bearings are not suitable for the compensation of angular misalignments. The extent to which a misalignment of the shaft can be tolerated relative to the housing bore is dependent on factors such as the design of the bearing arrangement, the size of the bearing, the operating clearance and the load etc. As a result, no guide value can be specified here for a possible misalignment. If angular misalignments occur, aligning needle roller bearings can, for example, be used in combination with an axial bearing, depending on the application.

! In all cases, misalignments cause increased running noise, place increased strain on the cages and have a harmful influence on the operating life of the bearings.

2.4 Lubrication

☞ *Greasing of the radial bearing component prior to initial operation*

In bearings with grease lubrication, the radial bearing component should be greased before initial operation using a grease of similar quality to that used in the axial bearing component.

☞ *Determining the relubrication interval*

In order to determine the relubrication interval, values must be calculated separately for the axial and radial bearing components and the lower values should be used.

☞ *Compatibility with plastic cages*

When using bearings with plastic cages, compatibility between the lubricant and the cage material must be ensured if synthetic oils, lubricating greases with a synthetic oil base or lubricants containing a high proportion of EP additives are used.

Needle roller/axial deep groove ball bearings

Type NX, NKX

☞ *NX, NKX for oil lubrication, NX..-Z, NKX..-Z for grease lubrication*

NX and NKX are intended for oil lubrication, therefore the bearings are not greased. Oil lubrication is carried out via the lubrication holes in the end cap ►966|☞5. If grease lubrication is intended, bearings of type NX..-Z or NKX..-Z should be used. In the case of these bearings, the axial bearing component is greased using a lithium complex soap grease to GA08. The end caps do not have lubrication holes.

Type NKX, NKX..-Z

☞ *Type NKX*

Type NKX does not have a cap which holds the axial bearing component together ►966|☞5. As a result, these bearings are not self-retaining. They should be used with oil lubrication in preference, as the lubricating grease can only be retained with difficulty in the axial bearing component.

☞ *Type NKX..-Z*

The bearings have an end cap without lubrication holes and are intended for grease lubrication ►964|2.1 and ►966|☞5. The axial bearing component is greased using a lithium complex soap grease to GA08.

Needle roller/axial cylindrical roller bearings

Type NKXR, NKXR..-Z

☞ *Type NKXR*

As the bearings do not have an end cap, the lubricating grease can only be retained with difficulty in the axial bearing component ►967|☞6. They should therefore be lubricated using oil in preference.

☞ *Type NKXR..-Z*

Bearings of this type have an end cap without lubrication holes and are intended for grease lubrication ►967|☞6. The axial bearing component is greased using a lithium complex soap grease to GA08.

Needle roller/angular contact ball bearings

☞ *Type NKIA, NKIB*

Needle roller/angular contact ball bearings can be lubricated with oil or grease. For lubrication, the outer ring has a lubrication groove and a lubrication hole ►967|☞8 and ►968|☞9. If grease lubrication is used, the radial and axial bearing components must be lubricated with the same grease prior to mounting the bearings.



2.5 Sealing

☞ Provide seals in the adjacent construction

Combined needle roller bearings are not sealed. In the case of unsealed bearings, sealing of the bearing position must be carried out in the adjacent construction. This must reliably prevent:

- moisture and contaminants from entering the bearing
- the egress of lubricant from the bearing.

13

Sealing of the bearing position in the adjacent construction – example

- ① Needle roller/axial deep groove ball bearing NX..-Z
- ② Sealing of the bearing with rotary shaft seal G

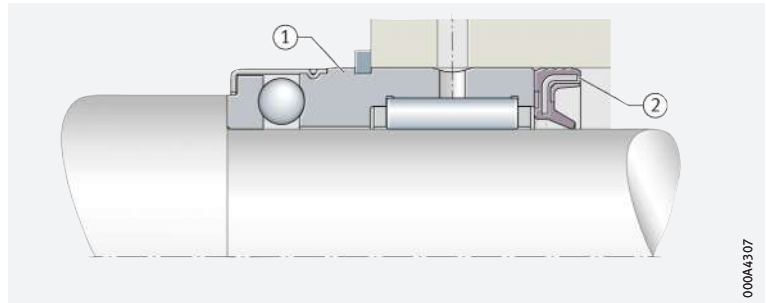

Bearings with end cap

☞ End caps without lubrication holes are suitable for grease lubrication

Bearings of design Z have an end cap, which grips the axial bearing component ▶964|2.1 and ▶965|④3, ▶966|④5 and ▶967|④6. End caps without lubrication holes form a gap seal and retain the lubricating grease in the axial bearing component (applies to types NX..-Z, NKX..-Z, NKXR..-Z).

2.6 Speeds

☞ Limiting speeds and reference speeds in the product tables

The product tables generally give two speeds for the bearings ▶984|④④④④:

- the kinematic limiting speed n_G
- the thermal speed rating $n_{\vartheta r}$.

Limiting speeds



The limiting speed n_G is the kinematically permissible speed of a bearing. Even under favourable mounting and operating conditions, this value should not be exceeded without prior consultation with Schaeffler ▶64. The values in the product tables are valid for oil lubrication.

☞ Values for grease lubrication

For grease lubrication, 60% of the value stated in the product tables is permissible in each case.

☞ $n_{\vartheta r}$ is used to calculate n_{ϑ}

Reference speeds

The thermal speed rating $n_{\vartheta r}$ is not an application-oriented speed limit, but is a calculated ancillary value for determining the thermally safe operating speed n_{ϑ} ▶64.

The thermally safe speed rating $n_{\vartheta r}$ for NKXR, NKXR..-Z, NKIA and NKIB is given in the product tables. The speed rating $n_{\vartheta r}$ to DIN ISO 15312:2004 is not defined for bearings NX and NKX and therefore only the limiting speed n_G is given.



In order to calculate the thermally safe operating speed n_{ϑ} , NKXR(..-Z) must be regarded as axial bearings and NKIA, NKIB as radial bearings.

2.7 Noise

Schaeffler Noise Index

The Schaeffler Noise Index (SGI) is not yet available for this bearing type ▶69. The data for these bearing series will be introduced and updated in stages.

Further information:

■ **medias** ▶<https://medias.schaeffler.com>.

2.8 Temperature range

Limiting values

The operating temperature of the bearings is limited by:

- the dimensional stability of the bearing rings and rolling elements
- the cage
- the lubricant.

Possible operating temperatures of combined needler roller bearings ▶422|3.

 **1**
Permissible temperature ranges

Operating temperature	Combined needle roller bearings Full complement ball type bearings, bearings with a sheet steel cage or polyamide cage PA66
	-30 °C to +120 °C



In the event of anticipated temperatures which lie outside the stated values, please contact Schaeffler.

2.9 Cages

Sheet steel or plastic cages are used as standard

The cages of radial bearings are made from sheet steel or plastic and are closed on both sides ▶984|3. Bearings with a polyamide cage PA66 have the suffix TV. The cages for the axial bearing component are closed on both sides or open on one side. Sheet steel or glass fibre reinforced polyamide PA66 are used here as standard, depending on the bearing type.



For high continuous temperatures and applications with difficult operating conditions, bearings with sheet steel cages should be used. If there is any uncertainty regarding cage suitability, please consult Schaeffler.

2.10 Internal clearance

The standard is CN

Radial internal clearance of bearings with inner ring

As standard, combined needler roller bearings with inner ring have the radial internal clearance CN (normal) ▶974|2. CN is not stated in the designation.



The values for radial internal clearance in bearings with an inner ring correspond to DIN 620-4:2004 (ISO 5753-1:2009) ▶974|2. These are valid for bearings which are free from load and measurement forces (without elastic deformation).



For delivery options of bearings with a radial internal clearance value other than CN (for example C2, C3, C4) please consult Schaeffler.



Bearings with inner ring

 **2**
Radial internal clearance
of combined needle
roller bearings with inner ring

Nominal bore diameter d		Radial internal clearance	
mm		CN	
over	incl.	min.	max.
–	24	20	45
24	30	20	45
30	40	25	50
40	50	30	60
50	65	40	70
65	80	40	75
80	100	50	85

 For bearings
without an inner ring,
the enveloping circle
diameter F_w is used

Enveloping circle diameter F_w for bearings without an inner ring

In the case of bearings without inner ring, the dimension for the enveloping circle diameter F_w is used instead of the radial internal clearance. The enveloping circle is the inner inscribed circle of the needle rollers in clearance-free contact with the outer raceway. Once the bearings are mounted, the enveloping circle diameter F_w is in the tolerance class F6. The precondition for this is that the bore tolerances are observed for bearings without an inner ring [▶977|2.16](#) and [▶978|](#) 6. Deviations for the tolerance class F6 [▶974|](#) 3.

 **3**
Deviations for the enveloping
circle diameter

Enveloping circle diameter F_w		Tolerance class F6 Tolerance for enveloping circle diameter F_w	
mm		upper deviation	lower deviation
over	incl.	μm	μm
3	6	+18	+10
6	10	+22	+13
10	18	+27	+16
18	30	+33	+20
30	50	+41	+25
50	80	+49	+30
80	120	+58	+36
120	180	+68	+43
180	250	+79	+50
250	315	+88	+56
315	400	+98	+62
400	500	+108	+68

2.11 Dimensions, tolerances

Dimension standards



The main dimensions of combined needle roller bearings correspond to ISO 15:2017 (DIN 616:2000 and DIN 5429-1:2005). This excludes needle roller/axial deep groove ball bearings of the types NX and NX..-Z, which are not standardised.

Chamfer dimensions



The limiting dimensions for chamfer dimensions correspond to DIN 620-6:2004. Overview and limiting values [▶135|7.11](#). Nominal value of chamfer dimension [▶984|](#).

Tolerances



The dimensional, geometrical and running tolerances of the bearings correspond to tolerance class Normal:

- Radial bearing component in accordance with ISO 492:2014 and DIN 620-2:1988. Tolerance values in accordance with ISO 492 >122|8
- Axial bearing component in accordance with ISO 199:2014 and DIN 620-3:1982. Tolerance values in accordance with ISO 199 >133|25.

This excludes:

- NKIB, in this instance the bore d_1 of the narrow inner ring and the width (-0,3 mm) over both inner rings
- NKX and NKXR, in this instance the diameters D_1, D_2 .

2.12

Suffixes

For a description of the suffixes used in this chapter >975|4 and **medias** interchange ><https://www.schaeffler.de/std/1D52>.

4
Suffixes and corresponding descriptions

Suffix	Description of suffix	
TV	Bearing with radial cage made from glass fibre reinforced polyamide 66	Standard
XL	X-life bearing	
Z	Bearing with end cap, axial bearing component greased with lithium complex soap grease to GA08	

2.13

Structure of bearing designation

Examples of composition of bearing designation

The designation of bearings follows a set model. Examples >975|14 to >976|16. The composition of designations is subject in part to DIN 623-1 >102|10.

14
Needle roller/axial deep groove ball bearing without inner ring, for grease lubrication: designation structure

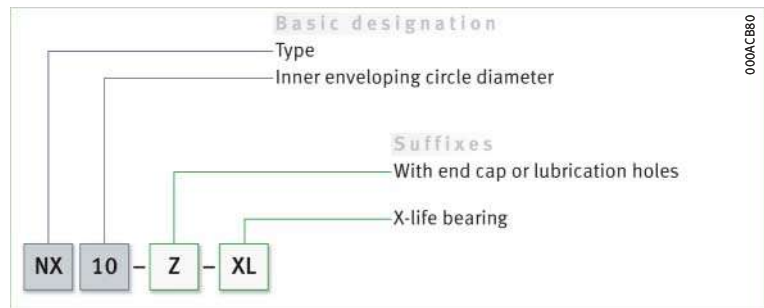

15
Needler roller/axial cylindrical roller bearing, with end cap, with recommended inner ring: designation structure

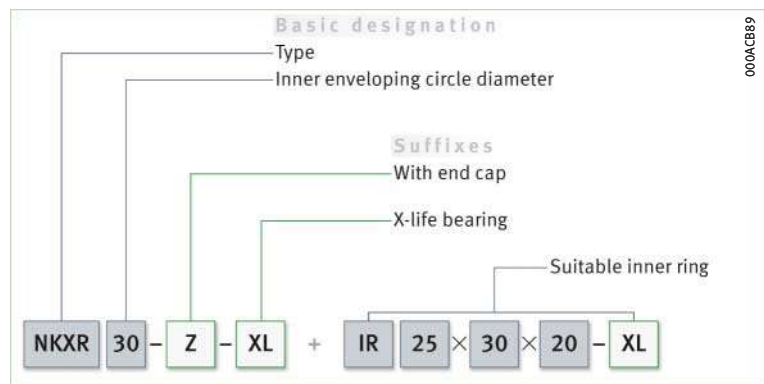

16
 Needle roller/angular contact ball bearing, double direction, with standard inner ring: designation structure

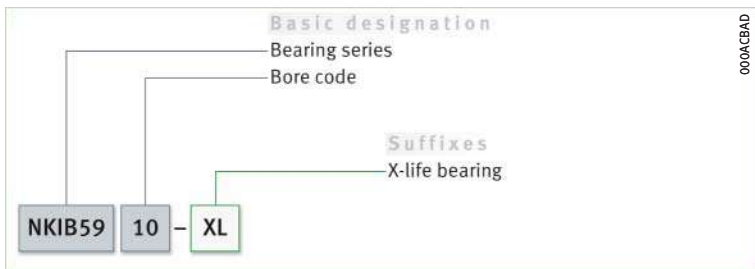

2.14 Dimensioning

Separate calculation of the rating life for radial and axial bearing components

$P = F_r$ and F_a respectively under purely radial load and purely axial load of constant magnitude and direction

Equivalent dynamic bearing load

In the case of combined needle roller bearings, the rating life of the radial bearing and axial bearing component must always be calculated separately ▶976 | f1 and ▶976 | f2. The lower value then applies in each case to the bearing position.

The basic rating life equation $L = (C/P)^P$ used in the dimensioning of bearings under dynamic load assumes a concentrically acting load of constant magnitude and direction. In the case of radial bearings, this is a purely radial load F_r , while in the case of axial bearings it is a purely axial load F_a . In order to calculate the fatigue rating life for combined needle roller bearings, the bearing load F_r or F_a ($P_r = F_r$ or $P_a = F_a$) is therefore used in the rating life equation for P ▶976 | f1 and ▶976 | f2.

Radial bearings



The radial component of the combined needle roller bearing may only be subjected to radial load. For the calculation of P_r ▶976 | f1.

f1
 Equivalent dynamic load

Legend

$P_r = F_r$		
P_r	N	Equivalent dynamic bearing load for the radial bearing
F_r	N	Radial load.

Axial bearing component

The axial bearing can only be subjected to axial load. For the calculation of P_a under a concentrically acting axial load ▶976 | f2.



For needle roller/angular contact ball bearings, the axial load F_a must not exceed $0,25 \cdot F_r$.

f2
 Equivalent dynamic load

Legend

$P_a = F_a$		
P_a	N	Equivalent dynamic bearing load for the axial bearing component
F_a	N	Axial load.

Equivalent static bearing load

The equivalent static bearing load must be calculated for both the radial bearing and the axial bearing component ▶976 | f3 and ▶976 | f4.

f3
 Equivalent static load



f4
 Equivalent static load

Legend

$P_{0r} = F_{0r}$		
P_{0r}	N	Equivalent static bearing load for the radial bearing
F_{0r}	N	Largest radial load present (maximum load)
P_{0a}	N	Equivalent static bearing load for the axial bearing component
F_{0a}	N	Largest axial load present (maximum load).

 S_{0a} for needle roller/
angular contact ball bearings

Static load safety factor

In addition to the basic rating life $L (L_{10h})$, it is also always necessary to check the static load safety factor S_0  977 |  5. The calculation must be carried out for both the radial bearing (S_{0r}) and the axial bearing component (S_{0a}). The axial static load safety factor S_{0a} must be $> 1,5$.

 5
Static load safety factor

$$S_0 = \frac{C_0}{P_0}$$

Legend

S_{0r}, S_{0a}	–	Static load safety factor
C_{0r}, C_{0a}	N	Basic static load rating
P_{0r}, P_{0a}	N	Equivalent static bearing load.

2.15 Minimum load

 In order to prevent damage due to slippage, a minimum radial load of $P > C_{0r}/60$ is required



Minimum radial load

In order that no slippage occurs between the contact partners, the radial bearing component must be constantly subjected to a sufficiently high load. For continuous operation, experience shows that a minimum radial load of the order of $P > C_{0r}/60$ is necessary. In most cases, however, the radial load is already higher than the requisite minimum load due to the weight of the supported parts and the external forces.







If the minimum radial load is lower than indicated above, please consult Schaeffler.

Minimum axial load

The axial component of the bearing arrangement must be preloaded to 1% of the axial basic static load rating C_{0a} . Basic load ratings C_{0a}  984 | .

2.16 Design of bearing arrangements

 Support bearing rings over their entire circumference and width

In order to allow full utilisation of the load carrying capacity of the bearings and achieve the requisite rating life, the bearing rings must be rigidly and uniformly supported by means of contact surfaces over their entire circumference and over the entire width of the raceway. Support can be provided by means of a cylindrical seating surface. The seating and contact surfaces should not be interrupted by grooves, holes or other recesses. The accuracy of mating parts must meet specific requirements  930 |  6 to  931 |  7.









Radial location

 For secure radial location, tight fits are necessary

In addition to supporting the rings adequately, the bearings must also be securely located in a radial direction, to prevent creep of the bearing rings on the mating parts (shaft and housing bore) under load. This is generally achieved by means of tight fits between the bearing rings and the mating parts. If the rings are not secured adequately or correctly, this can cause severe damage to the bearings and adjacent machine parts. Influencing factors, such as the conditions of rotation, magnitude of the load, internal clearance, temperature conditions, design of the mating parts, mounting and dismantling options etc., must be taken into consideration in the selection of fits.



The following information provided in Technical principles must be taken into consideration in the design of bearing arrangements:

- conditions of rotation  145
- tolerance classes for cylindrical shaft seats (radial bearings)  147 |  2
- shaft fits  150 |  6
- tolerance classes for bearing seats in housings (radial bearings)  148 |  4
- housing fits  158 |  7.

☞ *The bearings must also be securely located in an axial direction*

Axial location

As a tight fit alone is not normally sufficient to also locate the bearing rings securely on the shaft and in the housing bore in an axial direction, this must usually be achieved by means of an additional axial location or retention method. The axial location of the bearing rings must be matched to the type of bearing arrangement. Shaft and housing shoulders, retaining rings etc., are fundamentally suitable ▶969|⊕ 10, ▶970|⊕ 11 and ▶979|⊕ 18. For locating bearings and for bearings with a split inner ring (type NKIB), axial abutment of the bearing rings on both sides is particularly important.

☞ *Axial location by snap ring*

Types NX and NX..-Z

With types NX and NX..-Z, the retaining ring is inserted in the annular slot in the bearing outer ring ▶978|⊕ 17. Snap rings which are inserted in the slot are a particularly compact and cost-effective way of locating the bearings axially in the housing. Suitable snap rings ▶984|⊕ 6. The snap rings must be ordered in addition to the bearing.

⊕ 17
Combined needle roller bearing NX with a retaining ring located axially in the housing

① Annular Slot with retaining ring

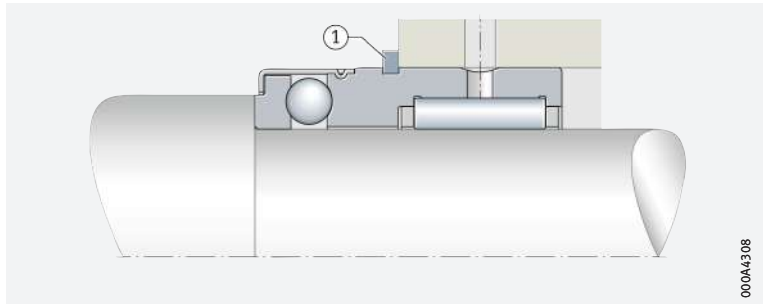

Type NKX, NKX..-Z

The axial location of these bearings in one direction can take place by means of the needle roller bearing with integrated housing locating washer.

Dimensional, geometrical and running accuracy of cylindrical bearing seats (bearings with inner ring)

Tolerance classes and surface designs for the shaft and the housing bore ▶978|⊕ 5 and ▶978|⊕ 6.

⊕ 5
Tolerance classes and surface design for the shaft – bearings with inner ring

Series	Shaft tolerance	Roundness tolerance max.	Parallelism tolerance max.
NKIA, NKIB	k6 ⊕	IT4/2	IT4
NX, NKX, NKXR			

⊕ 6
Tolerance classes and surface design for the housing bore

Series	Bore tolerance to ISO 286-2	Roundness tolerance max.	Parallelism tolerance max.
NKIA, NKIB	M6 ⊕	IT5/2	IT4
NX, NKX, NKXR	K6 ⊕, M6 ⊕ (for rigid bearing arrangements)		

⊕ 7
Numerical values for ISO standard tolerances (IT grades) to ISO 286-1:2010

IT grade	Nominal dimension in mm					
	over	6	10	18	30	50
	incl.	10	18	30	50	80
Values in μm						
IT4		4	5	6	7	8
IT5		6	8	9	11	13
IT6		9	11	13	16	19
IT7		15	18	21	25	30

Ra must not be too high

Roughness of cylindrical bearing seating surfaces

The roughness of the bearing seats must be matched to the tolerance class of the bearings. The mean roughness value Ra must not be too high, in order to maintain the interference loss within limits. The shafts must be ground, while the bores must be precision turned. Guide values as a function of the IT grade of bearing seating surfaces ▶ 979 | 8.

8
Roughness values
for cylindrical bearing seating
surfaces – guide values

Nominal diameter of the bearing seat d (D) mm		Recommended mean roughness value for ground bearing seats Ramax μm			
		Diameter tolerance (IT grade)			
over	incl.	IT7	IT6	IT5	IT4
–	80	1,6	0,8	0,4	0,2

The contact surfaces for the rings must be of sufficient height

Mounting dimensions

The mounting dimensions of the shaft and housing shoulders, spacer rings and retaining rings etc., must ensure that the contact surfaces for the bearing rings are of sufficient height. Proven mounting dimensions for the radii and diameters of abutment shoulders are given in the product tables ▶ 984 | 18. These dimensions are limiting dimensions (maximum or minimum dimensions); the actual values should not be higher or lower than specified.



The transition from the bearing seat to the abutment shoulder must be designed with rounding to DIN 5418 or an undercut to DIN 509. The maximum chamfer dimensions for the inner rings in accordance with DIN 620-6 must be taken into consideration.

For NKX and NKXR, the axial bearing component seat must be free in the housing

In order to avoid double fits, the diameter of the contact surface for the housing locating washer in the adjacent construction must be at least +0,5 mm larger than dimension D₁ and D₂ of the bearing washer in bearings NKX and NKXR ▶ 979 | 18. Values for diameters D₁ and D₂ ▶ 984 | 18.



Free housing locating washer in the adjacent construction for NKX and NKXR

D₁ = dimension of housing locating washer without end cap

D₂ = dimension of housing locating washer with end cap

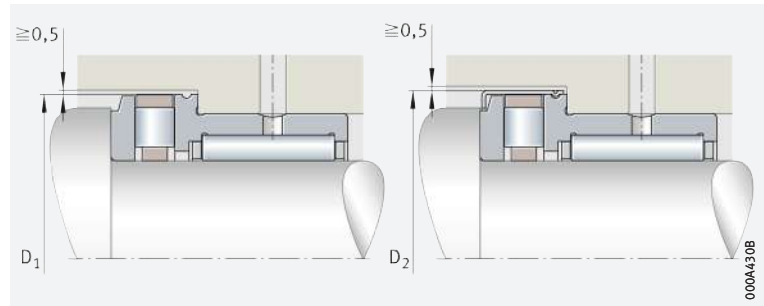

Raceway for bearings without an inner ring (direct bearing arrangement)

Produce the raceway as a rolling bearing raceway

Where needle roller bearings without an inner ring are used (so-called direct bearing arrangements), the rolling elements run directly on the shaft. In these bearings, the raceway for the rolling elements on the shaft must be produced as a rolling bearing raceway (hardened and ground). Tolerances and surface designs are shown in ▶ 979 | 9. The surface hardness of the raceway must be 670 HV to 840 HV, the hardening depth CHD or SHD must be sufficiently large. If the shaft cannot be produced as a raceway, the bearings can be combined with inner rings IR ▶ 964 | 2.1 and ▶ 984 | 18.

9
Tolerance classes and surface design for the shaft (direct bearing arrangement) – without inner ring

Series	Shaft tolerance	Roundness tolerance	Parallelism tolerance	Recommended mean roughness value Ramax (Rzmax) μm
NX, NKX, NKXR	k6 ©	max.	max.	0,1 (0,4)

Shaft raceway designed in accordance with DIN 617

! If the surface of the shaft raceway is produced to DIN 617, the basic load ratings C_r in the product tables must be reduced by 15%.

Steels for the raceway
Through hardening steels



Through hardening steels in accordance with ISO 683-17 (e.g. 100Cr6) are suitable as materials for rolling bearing raceways in direct bearing arrangements. These steels can also be surface layer hardened.

Case hardening steels



Case hardening steels must correspond to DIN EN ISO 683-17 (e.g. 17MnCr5, 18CrNiMo7-6) or EN 10084 (e.g. 16MnCr5).

Steels for inductive surface layer hardening



For flame and induction hardening, steels in accordance with DIN EN ISO 683-17 (e.g. C56E2, 43CrMo4) or DIN 17212 (e.g. Cf53) should be used.

Raceway hardness of less than 670 HV



If the raceway fulfils the requirements for rolling bearing materials but the raceway hardness is less than 670 HV, the load on the bearing arrangement cannot be as high as the full load carrying capacity of the bearing. In order to determine the dynamic and static load carrying capacity of the bearing arrangement, the basic dynamic load rating C of the bearings must be multiplied by the reduction factor f_H (dynamic hardness factor) and the basic static load rating C_{0r} by the reduction factor f_{H0} (static hardness factor) $\triangleright 980 | \text{ } \textcircled{19}$ and $\triangleright 980 | \text{ } \textcircled{20}$.

19
Dynamic hardness factor at reduced hardness of raceways/rolling elements

f_H = dynamic hardness factor
HV, HRC = surface hardness

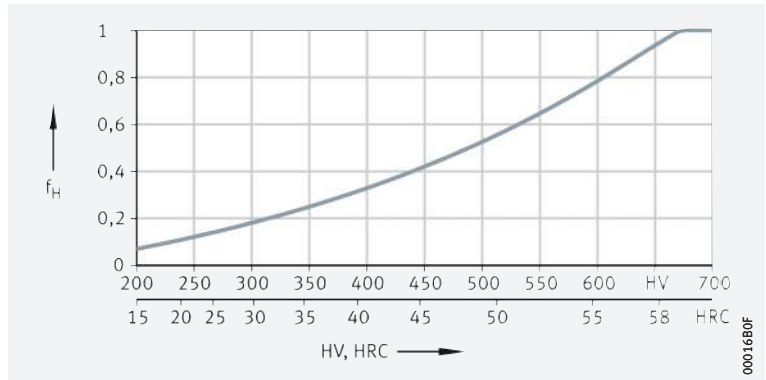

20
Static hardness factor at reduced hardness of raceways/rolling elements

f_{H0} = static hardness factor
HV, HRC = surface hardness

- ① Roller
- ② Ball

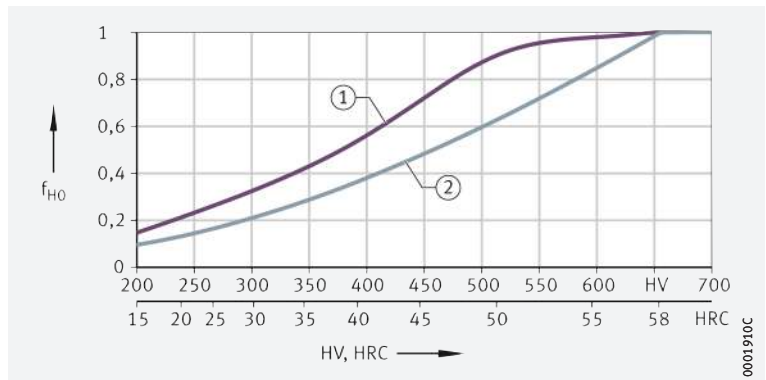

Approximation value for case hardening depth

Determining the case hardening depth

An approximation value for determining the minimum hardness depth is given in ►981 | f1 6. The reference value for the load present is the equivalent stress in accordance with the distortion energy hypothesis (DEH) as a function of the rolling element diameter D_w and the magnitude of the load.

f1 6
Case hardening depth

$$CHD \cong 0,052 \cdot D_w$$

Legend

CHD	mm	Case hardening depth
D_w	mm	Rolling element diameter.



The local hardness must always be above the local requisite hardness, which can be calculated from the equivalent stress.

Determining the surface hardening depth



In these surface hardening methods, the load and contact geometry must be taken into consideration when determining the requisite hardening depth.

For calculation of the surface hardening depth SHD ►981 | f1 7:

f1 7
Surface hardening depth

$$SHD \cong 140 \cdot D_w / R_{p0,2}$$

Legend

SHD	mm	Surface hardening depth
D_w	mm	Rolling element diameter
$R_{p0,2}$	N/mm ²	Yield point of base material.

2.17

Mounting and dismounting



The mounting and dismounting options for combined needle roller bearings, by thermal, hydraulic or mechanical methods, must be taken into consideration in the design of the bearing position.

As the bearings are not self-retaining, they are easy to mount

Combined needle roller bearings without an end cap are not self-retaining. As a result, the bearing parts can be mounted separately from each other ►964 | 2.1. This gives simplified mounting of the bearings, especially when the two bearing rings have a tight fit.

Schaeffler Mounting Handbook

Rolling bearings must be handled with great care

Rolling bearings are well-proven precision machine elements for the design of economical and reliable bearing arrangements, which offer high operational security. In order that these products can function correctly and achieve the envisaged operating life without detrimental effect, they must be handled with care.



The Schaeffler Mounting Handbook MH 1 gives comprehensive information about the correct storage, mounting, dismounting and maintenance of rotary rolling bearings ► <https://www.schaeffler.de/std/1D53>. It also provides information which should be observed by the designer, in relation to the mounting, dismounting and maintenance of bearings, in the original design of the bearing position. This book is available from Schaeffler on request.

2.18 Legal notice regarding data freshness

The further development of products may also result in technical changes to catalogue products

Of central interest to Schaeffler is the further development and optimisation of its products and the satisfaction of its customers. In order that you, as the customer, can keep yourself optimally informed about the progress that is being made here and with regard to the current technical status of the products, we publish any product changes which differ from the printed version in our electronic product catalogue.



We therefore reserve the right to make changes to the data and illustrations in this catalogue. This catalogue reflects the status at the time of printing. More recent publications released by us (as printed or digital media) will automatically precede this catalogue if they involve the same subject. Therefore, please always use our electronic product catalogue to check whether more up-to-date information or modification notices exist for your desired product.

Link to electronic product catalogue



The following link will take you to the Schaeffler electronic product catalogue: ► <https://medias.schaeffler.com>.

2.19 Further information



In addition to the data in this chapter, the following chapters in Technical principles must also be observed in the design of bearing arrangements:

- Determining the bearing size ► 34
- Rigidity ► 54
- Friction and increases in temperature ► 56
- Speeds ► 64
- Bearing data ► 97
- Lubrication ► 70
- Sealing ► 182
- Design of bearing arrangements ► 139
- Mounting and dismounting ► 191.





Needle roller/axial deep groove ball bearings

Without inner ring

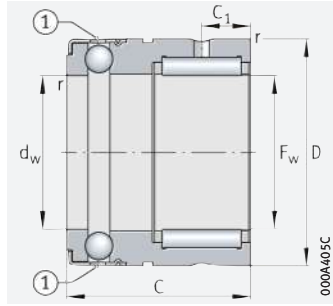

NX

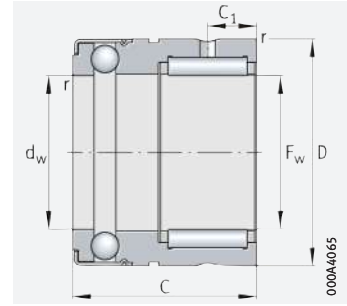

NX..Z

F_w = 7 – 35 mm

Main dimensions			Basic load ratings				Fatigue limit load		Limiting speed	Mass	Designation	
F _w	D	C	radial		axial		C _{ur}	C _{ua}			n _G	m
			dyn. C _r	stat. C _{0r}	dyn. C _a	stat. C _{0a}			N	N		
7	14	18	3 250	2 650	3 150	4 300	410	190	15 000	14	NX7-TV-XL	NX7-Z-TV-XL
10	19	18	5 000	3 700	4 600	7 200	720	320	11 000	25	NX10-XL	NX10-Z-XL
12	21	18	5 400	4 300	4 850	8 200	830	365	9 500	28	NX12-XL	NX12-Z-XL
15	24	28	12 100	12 700	5 600	10 400	2 320	460	8 000	48	NX15-XL	NX15-Z-XL
17	26	28	13 500	15 000	5 800	11 500	2 750	510	7 500	53	NX17-XL	NX17-Z-XL
20	30	28	14 600	17 500	7 000	14 700	3 200	650	6 500	68	NX20-XL	NX20-Z-XL
25	37	30	16 800	22 400	11 100	24 300	4 150	1 080	4 900	115	NX25-XL	NX25-Z-XL
30	42	30	25 500	36 000	11 700	28 000	6 300	1 230	4 300	130	NX30-XL	NX30-Z-XL
35	47	30	27 500	41 500	12 400	32 500	7 300	1 440	3 700	160	NX35-XL	NX35-Z-XL

medias ► <https://www.schaeffler.de/std/1E3F>

① Holes for lubricating oil

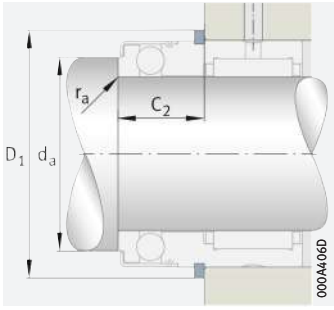

Mounting dimensions
Snap ring in outer ring

Dimensions				Mounting dimensions				Designation	
F_w	C_1	d_w	r	C_2	D_1	d_a	r_a	Recommended inner rings ▶ 992	Suitable snap rings
		E8	min.				max.		
7	4,7	7	0,3	10	16,5	9,6	0,3	–	WR14, SW14
10	4,7	10	0,3	10	21,9	14,6	0,3	IR6×10×10-IS1-XL	WR19, SW19
12	4,7	12	0,3	10	23,7	16,6	0,3	IR8×12×10-IS1-XL	WR21, SW21
15	8	15	0,3	12,2	26,5	19	0,3	IR12×15×16-XL	WR24, SW24
17	8	17	0,3	12,2	28,5	21	0,3	IR14×17×17-XL	WR26, SW26
20	8	20	0,3	12,2	33,6	25	0,3	IR17×20×16-XL	WR30, SW30
25	8	25	0,3	14,2	40,4	31,6	0,3	IR20×25×16-IS1-XL	WR37, SW37
30	10	30	0,3	14,2	45,1	36,5	0,3	IR25×30×20-XL	WR42, SW42
35	10	35	0,3	14,2	50,1	40,5	0,3	IR30×35×20-XL	WR47, SW47



Needle roller/axial deep groove ball bearings

Without inner ring
With or without end cap

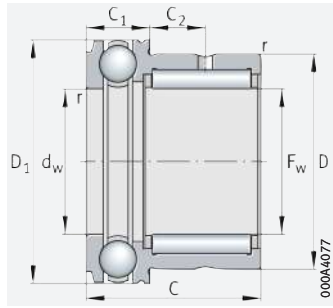

NKX

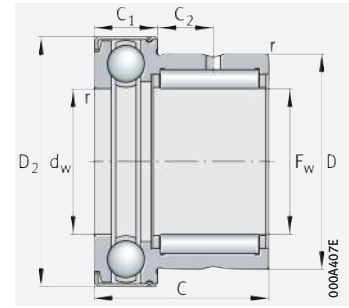

NKX..-Z

F_w = 10 – 70 mm

Main dimensions			Basic load ratings				Fatigue limit load		Limiting speed	Mass		Designation		
			radial		axial		C _{ur}	C _{ua}		n _G	Without end cap	With end cap	Without end cap	With end cap
F _w	D	C	dyn. C _r	stat. C _{0r}	dyn. C _a	stat. C _{0a}			N					
		-0,25	N	N	N	N	N	N						
10	19	23	7 000	7 800	10 000	14 000	1 310	670	12 400	34	36	NKX10-TV-XL	NKX10-Z-TV-XL	
12	21	23	10 100	11 000	10 300	15 400	1 920	740	11 000	38	40	NKX12-XL	NKX12-Z-XL	
15	24	23	12 100	12 700	10 500	16 800	2 320	810	9 500	44	47	NKX15-XL	NKX15-Z-XL	
17	26	25	13 500	15 000	10 800	18 200	2 750	870	8 500	53	55	NKX17-XL	NKX17-Z-XL	
20	30	30	18 600	23 800	14 200	24 700	4 150	1 190	7 500	83	90	NKX20-XL	NKX20-Z-XL	
25	37	30	21 300	30 500	19 600	37 500	5 300	1 790	6 000	125	132	NKX25-XL	NKX25-Z-XL	
30	42	30	25 500	36 000	20 400	42 000	6 300	2 030	5 000	141	148	NKX30-XL	NKX30-Z-XL	
35	47	30	27 500	41 500	21 200	47 000	7 300	2 270	4 600	163	168	NKX35-XL	NKX35-Z-XL	
40	52	32	29 500	47 000	27 000	63 000	8 300	3 000	4 000	200	208	NKX40-XL	NKX40-Z-XL	
45	58	32	31 000	53 000	28 000	69 000	9 300	3 350	3 600	252	265	NKX45-XL	NKX45-Z-XL	
50	62	35	43 000	74 000	29 000	75 000	12 700	3 650	3 300	280	300	NKX50-XL	NKX50-Z-XL	
60	72	40	47 500	90 000	41 500	113 000	15 400	5 400	2 800	360	380	NKX60-XL	NKX60-Z-XL	
70	85	40	50 000	92 000	43 000	127 000	15 700	6 100	2 400	500	520	NKX70-XL	NKX70-Z-XL	

medias ► <https://www.schaeffler.de/std/1E40>

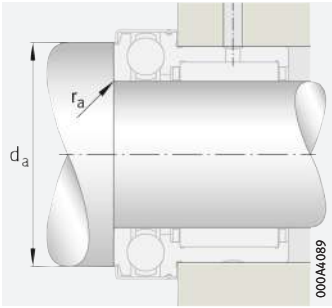

Mounting dimensions

Dimensions							Mounting dimensions		Designation
F_w	D_1 max.	D_2 max.	C_1 -0,2	C_2	d_w E8	r min.	d_a	r_a max.	Recommended inner rings ► 992
10	24,1	25,2	9	6,5	10	0,3	19,7	0,3	
12	26,1	27,2	9	6,5	12	0,3	21,7	0,3	IR9×12×16-XL
15	28,1	29,2	9	6,5	15	0,3	23,7	0,3	IR12×15×16-XL
17	30,1	31,2	9	8	17	0,3	25,7	0,3	IR14×17×17-XL
20	35,1	36,2	10	10,5	20	0,3	30,7	0,3	IR17×20×20-XL
25	42,1	43,2	11	9,5	25	0,6	37,7	0,6	IR20×25×20-XL
30	47,1	48,2	11	9,5	30	0,6	42,7	0,6	IR25×30×20-XL
35	52,1	53,2	12	9	35	0,6	47,7	0,6	IR30×35×20-XL
40	60,1	61,2	13	10	40	0,6	55,7	0,6	IR35×40×20-XL
45	65,2	66,5	14	9	45	0,6	60,5	0,6	IR40×45×20-XL
50	70,2	71,5	14	10	50	0,6	65,5	0,6	IR45×50×25-XL
60	85,2	86,5	17	12	60	1	80,5	1	IR50×60×25-XL
70	95,2	96,5	18	11	70	1	90,5	1	IR60×70×25-XL



Needle roller/axial cylindrical roller bearings

Without inner ring
With or without end cap

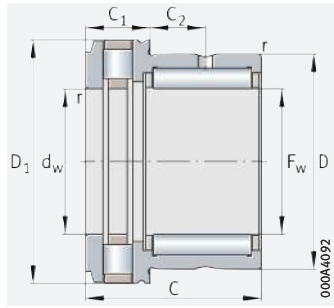

NKXR

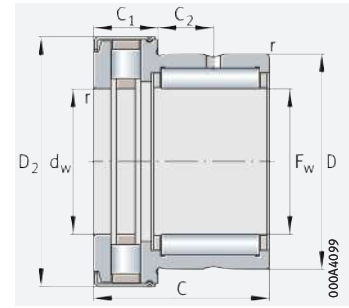

NKXR..-Z

F_w = 15 – 50 mm

Main dimensions			Basic load ratings				Limiting speed	Speed rating	Mass		Designation	
			radial		axial				Without end cap	With end cap	Without end cap	With end cap
F _w	D	C	dyn. C _r	stat. C _{0r}	dyn. C _a	stat. C _{0a}	n _G	n _{∂r}	m	m		
		-0,25	N	N	N	N	min ⁻¹	min ⁻¹	≈ g	≈ g		
15	24	23	12 100	12 700	14 400	28 500	13 000	6 500	42	45	NKXR15-XL	NKXR15-Z-XL
17	26	25	13 500	15 000	16 000	33 500	12 000	5 500	50	53	NKXR17-XL	NKXR17-Z-XL
20	30	30	18 600	23 800	25 000	53 000	10 000	4 200	80	84	NKXR20-XL	NKXR20-Z-XL
25	37	30	21 300	30 500	33 500	76 000	8 500	3 400	120	125	NKXR25-XL	NKXR25-Z-XL
30	42	30	25 500	36 000	35 500	86 000	7 500	2 900	135	141	NKXR30-XL	NKXR30-Z-XL
35	47	30	27 500	41 500	39 000	101 000	6 500	2 500	157	165	NKXR35-XL	NKXR35-Z-XL
40	52	32	29 500	47 000	56 000	148 000	6 000	2 000	204	214	NKXR40-XL	NKXR40-Z-XL
45	58	32	31 000	53 000	59 000	163 000	5 000	1 900	244	260	NKXR45-XL	NKXR45-Z-XL
50	62	35	43 000	74 000	62 000	177 000	4 800	1 700	268	288	NKXR50-XL	NKXR50-Z-XL

medias ► <https://www.schaeffler.de/std/1E41>

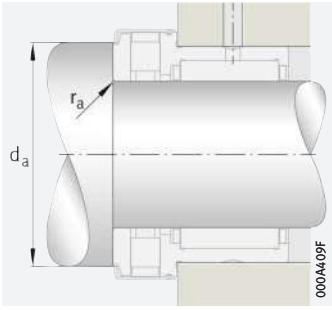

Mounting dimensions

F _w	Fatigue limit load		Dimensions						Mounting dimensions		Designation Recommended inner rings ► 992
	C _{ur} N	C _{ua} N	D ₁ max.	D ₂ max.	C ₁ -0,2	C ₂	d _w E8	r min.	d _a	r _a max.	
15	2 320	4 000	28,1	29,2	9	6,5	15	0,3	23,7	0,3	IR12×15×16-XL
17	2 750	4 650	30,1	31,2	9	8	17	0,3	25,7	0,3	IR14×17×17-XL
20	4 150	7 300	35,1	36,2	10	10,5	20	0,3	30,7	0,3	IR17×20×20-XL
25	5 300	7 100	42,1	43,2	11	9,5	25	0,6	37,7	0,6	IR20×25×20-XL
30	6 300	8 000	47,1	48,2	11	9,5	30	0,6	42,7	0,6	IR25×30×20-XL
35	7 300	9 500	52,1	53,2	12	9	35	0,6	47,7	0,6	IR30×35×20-XL
40	8 300	14 500	60,1	61,2	13	10	40	0,6	55,7	0,6	IR35×40×20-XL
45	9 300	16 000	65,2	66,5	14	9	45	0,6	60,6	0,6	IR40×45×20-XL
50	12 700	17 400	70,2	71,5	14	10	50	0,6	65,5	0,6	IR45×50×25-XL

Needle roller/angular contact ball bearings

With inner ring

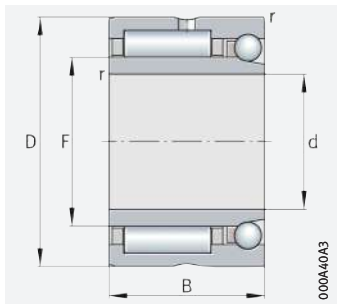

NKIA
Single direction

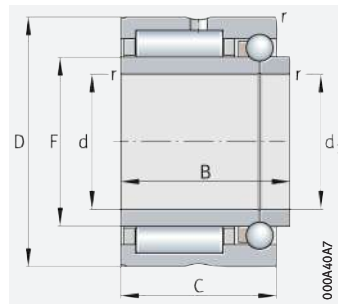

NKIB
Double direction

d = 12 – 70 mm

Main dimensions			Basic load ratings				Fatigue limit load		Limiting speed	Speed rating	Mass	Designation ▶975 2.12 ▶975 2.13 X-life ▶968
d	D	B	radial		axial		C _{ur}	C _{ua}	n _G	n _{θr}	m	
			dyn. C _r N	stat. C _{0r} N	dyn. C _a N	stat. C _{0a} N						
12	24	16	8 600	8 300	2 700	3 450	1 630	152	23 600	21 000	40	NKIA5901-XL
	24	17,5	8 600	8 300	2 700	3 450	1 630	152	23 600	21 000	43	NKIB5901-XL
15	28	18	12 000	13 600	2 900	4 200	2 430	186	21 600	17 000	50	NKIA5902-XL
	28	20	12 000	13 600	2 900	4 200	2 430	186	21 600	17 000	52	NKIB5902-XL
17	30	18	12 400	14 600	3 150	4 900	2 600	216	20 600	15 000	56	NKIA5903-XL
	30	20	12 400	14 600	3 150	4 900	2 600	216	20 600	15 000	58	NKIB5903-XL
20	37	23	23 700	25 500	4 900	7 400	4 600	330	17 200	14 000	103	NKIA5904-XL
	37	25	23 700	25 500	4 900	7 400	4 600	330	17 200	14 000	107	NKIB5904-XL
22	39	23	26 000	29 500	5 300	8 600	5 300	380	16 100	12 000	118	NKIA59/22-XL
	39	25	26 000	29 500	5 300	8 600	5 300	380	16 100	12 000	122	NKIB59/22-XL
25	42	23	26 500	31 500	5 400	9 300	5 700	410	14 600	12 000	130	NKIA5905-XL
	42	25	26 500	31 500	5 400	9 300	5 700	410	14 600	12 000	134	NKIB5905-XL
30	47	23	28 500	35 500	5 900	11 200	6 400	495	12 700	10 000	147	NKIA5906-XL
	47	25	28 500	35 500	5 900	11 200	6 400	495	12 700	10 000	151	NKIB5906-XL
35	55	27	35 500	50 000	7 400	14 900	9 400	660	10 900	9 000	243	NKIA5907-XL
	55	30	35 500	50 000	7 400	14 900	9 400	660	10 900	9 000	247	NKIB5907-XL
40	62	30	48 500	67 000	9 200	19 400	11 500	860	9 600	7 500	315	NKIA5908-XL
	62	34	48 500	67 000	9 200	19 400	11 500	860	9 600	7 500	320	NKIB5908-XL
45	68	30	51 000	73 000	9 600	21 400	12 600	950	8 700	7 000	375	NKIA5909-XL
	68	34	51 000	73 000	9 600	21 400	12 600	950	8 700	7 000	380	NKIB5909-XL
50	72	30	53 000	80 000	10 100	24 300	13 800	1 080	8 000	6 500	380	NKIA5910-XL
	72	34	53 000	80 000	10 100	24 300	13 800	1 080	8 000	6 500	385	NKIB5910-XL
55	80	34	65 000	100 000	12 100	29 500	17 300	1 300	7 300	6 000	550	NKIA5911-XL
	80	38	65 000	100 000	12 100	29 500	17 300	1 300	7 300	6 000	555	NKIB5911-XL
60	85	34	68 000	108 000	12 400	32 000	18 800	1 410	6 800	5 500	590	NKIA5912-XL
	85	38	68 000	108 000	12 400	32 000	18 800	1 410	6 800	5 500	595	NKIB5912-XL
65	90	34	69 000	112 000	12 800	34 000	19 500	1 510	6 300	5 500	635	NKIA5913-XL
	90	38	69 000	112 000	12 800	34 000	19 500	1 510	6 300	5 500	640	NKIB5913-XL
70	100	40	95 000	156 000	16 800	44 500	27 500	1 970	5 800	4 900	980	NKIA5914-XL
	100	45	95 000	156 000	16 800	44 500	27 500	1 970	5 800	4 900	985	NKIB5914-XL

medias ▶ <https://www.schaeffler.de/std/1E42>



Dimensions

d	F	C	r
			min.
12	16	–	0,3
	16	16	0,3
15	20	–	0,3
	20	18	0,3
17	22	–	0,3
	22	18	0,3
20	25	–	0,3
	25	23	0,3
22	28	–	0,3
	28	23	0,3
25	30	–	0,3
	30	23	0,3
30	35	–	0,3
	35	23	0,3
35	42	–	0,6
	42	27	0,6
40	48	–	0,6
	48	30	0,6
45	52	–	0,6
	52	30	0,6
50	58	–	0,6
	58	30	0,6
55	63	–	1
	63	34	1
60	68	–	1
	68	34	1
65	72	–	1
	72	34	1
70	80	–	1
	80	40	1



3 Inner rings



Inner rings are used where:

- the shaft cannot be used as a rolling bearing raceway for needle roller and cage assemblies, drawn cup needle roller bearings with open ends, drawn cup needle roller bearings with closed ends and needle roller bearings (it cannot be hardened and ground)
- needle roller bearings must be combined with wider inner rings in order to allow larger axial displacements of the shaft in relation to the housing (e.g. in bearings with a non-locating bearing function)
- optimum running surfaces are required for seal lips ▶ 992 | 1 and ▶ 994 | 4.



Wider inner ring, outside surface used as raceway for seal lip

- ① Inner ring IR
- ② Sealing ring G

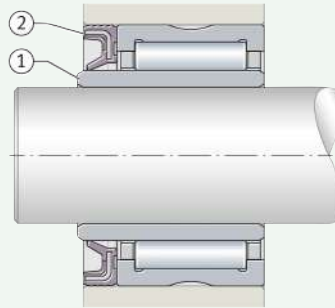

3.1 Product design

Design variants

The bearing components are available as:

- inner ring IR ▶ 992 | 2
- inner ring LR ▶ 993 | 3.

The raceway is precision machined

Inner rings IR

Inner rings IR are made from hardened rolling bearing steel and have precision machined raceways ▶ 992 | 2. Chamfers on the end faces facilitate the matching of the rings with the needle roller and cage assembly or of the bearing ring with the needle roller set and prevent damage to the seal lips of the bearings. Inner rings are available with and without a lubrication hole ▶ 992 | 2. Rings with a lubrication hole have the suffix IS1 ▶ 995 | 3.5, ▶ 998 | 4.

Inner rings are also available by agreement with several lubrication holes.



Inner rings IR

- ① Inner ring without lubrication hole
- ② Inner ring with lubrication hole

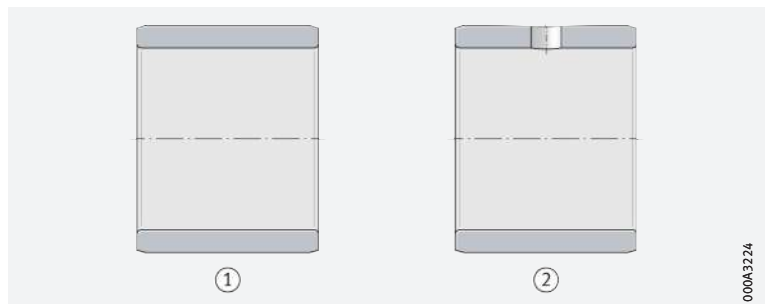

000A3224



X-life premium quality

Inner rings IR are supplied in the X-life design. The quality of the inner rings corresponds to the quality of X-life needle roller bearings. X-life inner rings include the suffix XL in the designation ►996|Ⓞ 6.



X-life indicates a high product performance density and thus a particularly significant benefit to the customer. Further information on X-life ►10.

Inner rings with the machining allowance “z” (special design)

Ⓞ z = a material allowance for finish grinding of the rings after fitting, where there are high demands on running accuracy

Inner rings are also available as a special design with a machining allowance “z” on the raceway. These inner rings have the suffix VGS ►995|3.5. The size of the machining allowance is dependent on the diameter of the inner ring raceway ►993|Ⓞ 1. The raceway is finish ground once the rings have been fitted, if high demands are placed on the running accuracy of the bearings.

Ⓞ 1
Machining allowance

Raceway diameter F mm		Machining allowance z mm	Preground raceway diameter F _{VGS}
over	incl.		
-	50	0,1	F _{VGS} = F + z (tolerance h7 Ⓞ)
50	80	0,15	
80	180	0,2	
180	250	0,25	
250	315	0,3	
315	400	0,35	
400	500	0,4	

Inner rings LR

Ⓞ The raceway is ground

Inner rings LR are produced from rolling bearing steel and are hardened ►993|Ⓞ 3. The bore and running surface are ground. The end faces are not ground (turned) and the edges are broken. These rings have larger tolerances than the inner rings IR. As a result, they are particularly suitable for applications that allow larger width tolerances and less demanding requirements for axial runout. It is here that they give particularly economical bearing arrangements.



Catalogue HR 1 does not contain separate product tables for inner rings LR. Available inner rings LR are listed in the product tables for drawn cup needle roller bearings with open ends and with closed end ►900|Ⓞ.

For other available dimensions, please consult Schaeffler.

Ⓞ 3
Inner ring LR

- d = bore diameter
- F = raceway diameter
- B = width

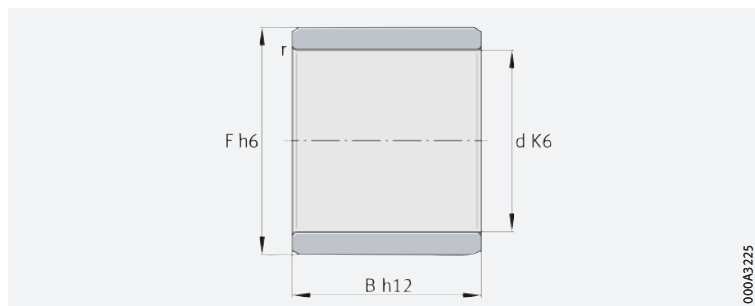

000A3225

Advantages of wider inner rings

Wider inner rings

The inner rings are available in several widths within the respective bore diameters >998|. Wider inner rings:

- permit larger axial displacements of the shaft in relation to the housing
- can be used as the running surface for the lips of contact seals, for example when using sealing rings G, GR and SD >994|

4
Wider inner ring, also used as running surface for sealing rings

- ① Wider inner ring IR
- ② Sealing ring G
- ③ Sealing ring SD

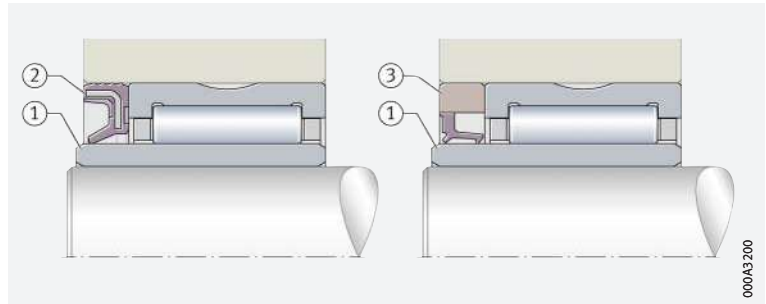

3.2 Temperature range

Limiting values

The operating temperature of the inner rings is limited by the dimensional stability of the ring material >994| 2.

2
Permissible temperature ranges

Operating temperature	Inner rings
	-30 °C to +120 °C



In the event of anticipated temperatures which lie outside the stated values, please contact Schaeffler.

3.3 Internal clearance

CN for the combination of needler roller bearing/inner ring

The radial internal clearance is dependent on the bearing design used in combination with the inner ring. When combined with Schaeffler needle roller bearings, inner rings have a radial internal clearance of CN >994| 3.

C2 to C3 for the combination of drawn cup needle roller bearing with open ends or closed end/inner ring

When combined with Schaeffler drawn cup needle roller bearings with open ends or closed end, inner rings have an internal clearance of C2 to C3, depending on the raceway diameter >994| 3.



The values for radial internal clearance correspond to DIN 620-4:2004 (ISO 5753-1:2009). These are valid for bearings which are free from load and measurement forces (without elastic deformation).

3
Radial internal clearance

Nominal bore diameter		Radial internal clearance							
		C2 (Group 2)		CN (Group N)		C3 (Group 3)		C4 (Group 4)	
mm		µm		µm		µm		µm	
over	incl.	min.	max.	min.	max.	min.	max.	min.	max.
-	24	0	25	20	45	35	60	50	75
24	30	0	25	20	45	35	60	50	75
30	40	5	30	25	50	45	70	60	85
40	50	5	35	30	60	50	80	70	100

continued ▾

 **3**
Radial internal clearance

Nominal bore diameter d mm		Radial internal clearance							
		C2 (Group 2)		CN (Group N)		C3 (Group 3)		C4 (Group 4)	
		μm		μm		μm		μm	
over	incl.	min.	max.	min.	max.	min.	max.	min.	max.
50	65	10	40	40	70	60	90	80	110
65	80	10	45	40	75	65	100	90	125
80	100	15	50	50	85	75	110	105	140
100	120	15	55	50	90	85	125	125	165
120	140	15	60	60	105	100	145	145	190
140	160	20	70	70	120	115	165	165	215
160	180	25	75	75	125	120	170	170	220
180	200	35	90	90	145	140	195	195	250
200	225	45	105	105	165	160	220	220	280
225	250	45	110	110	175	170	235	235	300
250	280	55	125	125	195	190	260	260	330
280	315	55	130	130	205	200	275	275	350
315	355	65	145	145	225	225	305	305	385
355	400	100	190	190	280	280	370	370	460
400	450	110	210	210	310	310	410	410	510

continued ▲

3.4 Tolerances



The tolerances for the dimensional and running accuracy of inner rings IR correspond to tolerance class Normal in accordance with ISO 492:2014. Tolerance values in accordance with ISO 492 ►122| 8.

3.5 Suffixes

For a description of the suffixes used in this chapter ►995| 4 and **medias** interchange ►<https://www.schaeffler.de/std/1D52>.

 **4**
Suffixes and corresponding descriptions

Suffix	Description of suffix	
C2	Radial internal clearance C2 (smaller than normal)	Standard or special design, depending on the rolling bearing used
C3	Radial internal clearance C3 (larger than normal)	
C4	Radial internal clearance C4 (larger than C3)	
EGS	Surface ground free from spiral marks for rotary shaft seals to DIN 3760 and DIN 3761	Special design, available by agreement
IS1	With lubrication hole	Standard for IR inner rings within certain limits
VGS	Machining allowance “z” on raceway ►993  1	Special design, available by agreement

3.6 Structure of bearing designation

The designation of inner rings follows a set model. Examples ▶996| 5 and ▶996| 6.

 5
Inner ring LR:
designation structure

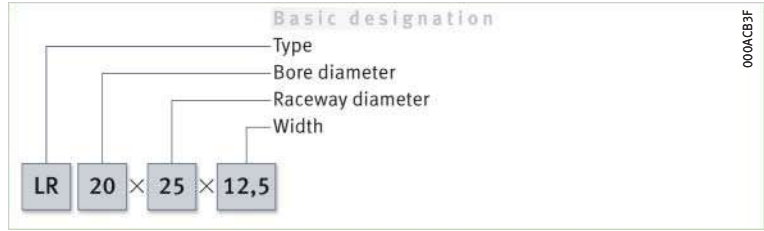

 6
Inner ring IR
with lubrication hole:
designation structure

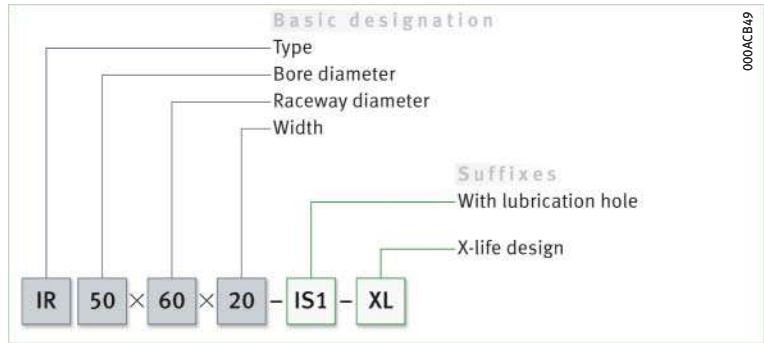

3.7 Design of bearing arrangements

Axial location of inner rings

 Always locate inner rings axially on both sides

The bearing rings must not be allowed to undergo lateral creep. In order to reliably prevent axial displacements of the inner rings on the shaft where a tight or loose fit is present, these must be located axially on both sides. On one side, the rings can be abutted against a shaft shoulder and, for location on the opposing side, retaining rings, spacer rings or shaft nuts are suitable ▶996| 7.

 Design of adjacent parts

The abutment shoulders for the rings should be sufficiently high and perpendicular to the bearing axis. The transition from the bearing seat to the abutment shoulder must be designed with rounding to DIN 5418 or an undercut to DIN 509. In this instance, the minimum values for the chamfer dimensions in the product tables must be observed ▶998| 4.

The overlap between the retaining rings and the end faces of the bearing rings must be sufficiently large ▶996| 7.



The maximum chamfer dimensions for the inner rings in accordance with DIN 620-6 must be taken into consideration.

 7
Inner ring axially located
on both sides

- 1 Retaining ring
- 2 Drawn cup needle roller bearing with open ends HK
- 3 Shaft shoulder
- 4 Inner ring IR

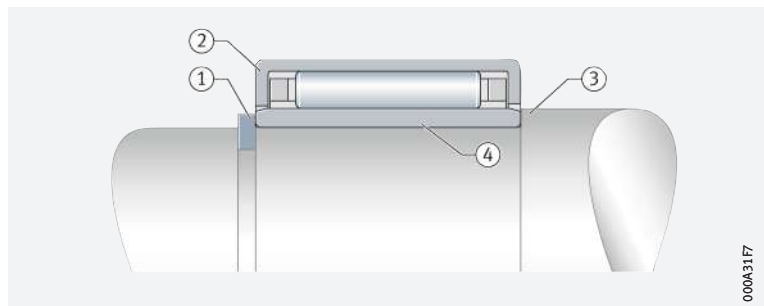

3.8 Mounting and dismounting

Rolling bearings must be handled with great care

Schaeffler Mounting Handbook

Rolling bearings are well-proven precision machine elements for the design of economical and reliable bearing arrangements, which offer high operational security. In order that these products can function correctly and achieve the envisaged operating life without detrimental effect, they must be handled with care.



The Schaeffler Mounting Handbook MH 1 gives comprehensive information about the correct storage, mounting, dismounting and maintenance of rotary rolling bearings ► <https://www.schaeffler.de/std/1D53>. It also provides information which should be observed by the designer, in relation to the mounting, dismounting and maintenance of bearings, in the original design of the bearing position. This book is available from Schaeffler on request.

3.9 Legal notice regarding data freshness

The further development of products may also result in technical changes to catalogue products

Of central interest to Schaeffler is the further development and optimisation of its products and the satisfaction of its customers. In order that you, as the customer, can keep yourself optimally informed about the progress that is being made here and with regard to the current technical status of the products, we publish any product changes which differ from the printed version in our electronic product catalogue.



We therefore reserve the right to make changes to the data and illustrations in this catalogue. This catalogue reflects the status at the time of printing. More recent publications released by us (as printed or digital media) will automatically precede this catalogue if they involve the same subject. Therefore, please always use our electronic product catalogue to check whether more up-to-date information or modification notices exist for your desired product.

Link to electronic product catalogue



The following link will take you to the Schaeffler electronic product catalogue: ► <https://medias.schaeffler.com>.





Inner rings

Without lubrication hole

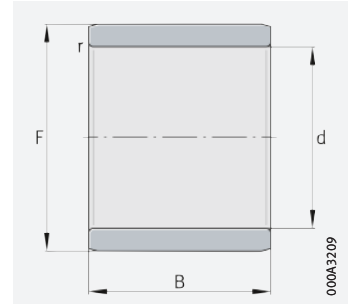

IR

d = 5 – 25 mm

Main dimensions				Mass m ≈ g	Designation ► 995 3.5 ► 996 3.6 X-life ► 993	Deviations for raceway F	
d	F	B	r min.			upper μm	lower μm
5	8	12	0,3	2,8	IR5×8×12-XL	-7	-23
	8	16	0,3	3,7	IR5×8×16-XL	-7	-23
6	9	12	0,3	3	IR6×9×12-XL	-7	-23
	9	16	0,3	4,3	IR6×9×16-XL	-7	-23
7	10	10,5	0,3	3,1	IR7×10×10,5-XL	-7	-23
	10	12	0,3	3,6	IR7×10×12-XL	-7	-23
	10	16	0,3	4,9	IR7×10×16-XL	-7	-23
8	12	10,5	0,3	5	IR8×12×10,5-XL	-4	-18
	12	12,5	0,3	5,9	IR8×12×12,5-XL	-4	-18
9	12	12	0,3	4,4	IR9×12×12-XL	-4	-18
	12	16	0,3	6	IR9×12×16-XL	-4	-18
10	13	12,5	0,3	5,2	IR10×13×12,5-XL	-4	-18
	14	13	0,3	7,4	IR10×14×13-XL	-4	-18
	14	16	0,3	9,2	IR10×14×16-XL	-4	-18
	14	20	0,3	11,5	IR10×14×20-XL	-4	-18
12	15	12	0,3	5,7	IR12×15×12-XL	-4	-18
	15	12,5	0,3	6,1	IR12×15×12,5-XL	-4	-18
	15	16	0,3	7,6	IR12×15×16-XL	-4	-18
	15	16,5	0,3	8,1	IR12×15×16,5-XL	-4	-18
	15	22,5	0,3	10,9	IR12×15×22,5-XL	-4	-18
	16	13	0,3	8,5	IR12×16×13-XL	-4	-18
	16	16	0,3	10,7	IR12×16×16-XL	-4	-18
	16	20	0,3	13,5	IR12×16×20-XL	-4	-18
14	17	17	0,3	9,5	IR14×17×17-XL	-4	-18
	17	20	0,3	11,5	IR14×17×20-XL	-4	-18
15	18	16	0,3	9,4	IR15×18×16-XL	-4	-18
	18	16,5	0,3	9,8	IR15×18×16,5-XL	-4	-18
	19	16	0,3	12,9	IR15×19×16-XL	0	-12
	19	20	0,3	16,3	IR15×19×20-XL	0	-12
	20	13	0,3	13,5	IR15×20×13-XL	0	-12
	20	23	0,3	24,4	IR15×20×23-XL	0	-12

medias ► <https://www.schaeffler.de/std/1E7F>



Main dimensions				Mass m ≈ g	Designation ► 995 3.5 ► 996 3.6 X-life ► 993	Deviations for raceway F	
d	F	B	r min.			upper μm	lower μm
17	20	16	0,3	10,6	IR17×20×16-XL	0	-12
	20	16,5	0,3	11,1	IR17×20×16,5-XL	0	-12
	20	20	0,3	13,5	IR17×20×20-XL	0	-12
	20	20,5	0,3	13,8	IR17×20×20,5-XL	0	-12
	20	30,5	0,3	20,6	IR17×20×30,5-XL	0	-12
	21	16	0,3	15	IR17×21×16-XL	0	-12
	21	20	0,3	18	IR17×21×20-XL	0	-12
	22	13	0,3	14,9	IR17×22×13-XL	0	-12
	22	16	0,3	18,4	IR17×22×16-XL	0	-12
	22	23	0,3	27,1	IR17×22×23-XL	0	-12
	24	20	0,6	33,8	IR17×24×20-XL	0	-12
20	24	16	0,3	15	IR20×24×16-XL	0	-12
	24	20	0,3	21,3	IR20×24×20-XL	0	-12
	25	17	0,3	25	IR20×25×17-XL	0	-12
	25	20	0,3	27,5	IR20×25×20-XL	0	-12
	25	20,5	0,3	27,4	IR20×25×20,5-XL	0	-12
	25	26,5	0,3	38	IR20×25×26,5-XL	0	-12
	25	30	0,3	40,4	IR20×25×30-XL	0	-12
	25	38,5	0,3	52,5	IR20×25×38,5-XL	0	-12
	28	20	0,6	45,2	IR20×28×20-XL	0	-12
22	26	16	0,3	18,2	IR22×26×16-XL	0	-12
	28	17	0,3	29,5	IR22×28×17-XL	0	-12
	26	20	0,3	23	IR22×26×20-XL	0	-12
	28	20	0,3	35	IR22×28×20-XL	0	-12
	28	20,5	0,3	36	IR22×28×20,5-XL	0	-12
	28	30	0,3	54,4	IR22×28×30-XL	0	-12
25	29	20	0,3	25,9	IR25×29×20-XL	0	-12
	29	30	0,3	39,3	IR25×29×30-XL	0	-12
	30	17	0,3	27,4	IR25×30×17-XL	0	-12
	30	20	0,3	32,8	IR25×30×20-XL	0	-12
	30	20,5	0,3	33,4	IR25×30×20,5-XL	0	-12
	30	26,5	0,3	46	IR25×30×26,5-XL	0	-12
	30	30	0,3	53	IR25×30×30-XL	0	-12
	30	32	0,3	56	IR25×30×32-XL	0	-12
	30	38,5	0,3	64,5	IR25×30×38,5-XL	0	-12
	32	22	0,6	52,5	IR25×32×22-XL	+5	-4

medias ► <https://www.schaeffler.de/std/1E80>





Inner rings

Without lubrication hole

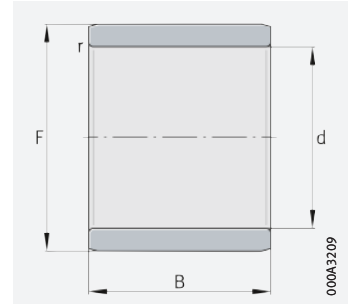

IR

d = 28 – 70 mm

Main dimensions				Mass m ≈ g	Designation ► 995 3.5 ► 996 3.6 X-life ► 993	Deviations for raceway F	
d	F	B	r min.			upper μm	lower μm
28	32	17	0,3	24,5	IR28×32×17-XL	+5	-4
	32	20	0,3	28,5	IR28×32×20-XL	+5	-4
	32	30	0,3	43,5	IR28×32×30-XL	+5	-4
30	35	13	0,3	25	IR30×35×13-XL	+5	-4
	35	16	0,3	34	IR30×35×16-XL	+5	-4
	35	17	0,3	36	IR30×35×17-XL	+5	-4
	35	20	0,3	39	IR30×35×20-XL	+5	-4
	35	20,5	0,3	39,7	IR30×35×20,5-XL	+5	-4
	35	26	0,3	50,4	IR30×35×26-XL	+5	-4
	35	30	0,3	58,5	IR30×35×30-XL	+5	-4
	37	18	0,6	50	IR30×37×18-XL	+5	-4
32	37	22	0,6	61,6	IR30×37×22-XL	+5	-4
	37	20	0,3	42	IR32×37×20-XL	0	-9
32	37	30	0,3	62	IR32×37×30-XL	0	-9
	40	20	0,6	68	IR32×40×20-XL	0	-9
	40	36	0,6	124	IR32×40×36-XL	0	-9
33	37	13	0,3	21,9	IR33×37×13-XL	0	-9
35	40	17	0,3	37,8	IR35×40×17-XL	0	-9
	40	20	0,3	44,2	IR35×40×20-XL	0	-9
	40	20,5	0,3	46,1	IR35×40×20,5-XL	0	-9
	40	30	0,3	67,1	IR35×40×30-XL	0	-9
	42	36	0,6	117,2	IR35×42×36-XL	0	-9
	43	22	0,6	82	IR35×43×22-XL	0	-9
38	43	20	0,3	48,1	IR38×43×20-XL	0	-9
	43	30	0,3	73,6	IR38×43×30-XL	0	-9
40	45	17	0,3	42,5	IR40×45×17-XL	0	-9
	45	20	0,3	50,8	IR40×45×20-XL	0	-9
	45	20,5	0,3	51,8	IR40×45×20,5-XL	0	-9
	45	30	0,3	84	IR40×45×30-XL	0	-9
	48	22	0,6	91,6	IR40×48×22-XL	0	-9
	48	40	0,6	170	IR40×48×40-XL	0	-9
	50	22	1	118	IR40×50×22-XL	0	-9
42	47	20	0,3	52,8	IR42×47×20-XL	-5	-19
	47	30	0,3	81	IR42×47×30-XL	-5	-19

medias ► <https://www.schaeffler.de/std/1E81>



Main dimensions				Mass m ≈ g	Designation ▶ 995 3.5 ▶ 996 3.6 X-life ▶ 993	Deviations for raceway F	
d	F	B	r min.			upper μm	lower μm
45	50	25	0,6	70,8	IR45×50×25-XL	-5	-19
	50	25,5	0,3	75,1	IR45×50×25,5-XL	-5	-19
	50	35	0,6	101	IR45×50×35-XL	-5	-19
	52	22	0,6	89	IR45×52×22-XL	0	-11
	52	40	0,6	164	IR45×52×40-XL	0	-11
	55	22	1	129	IR45×55×22-XL	0	-11
50	55	25	0,6	78	IR50×55×25-XL	0	-11
	55	35	0,6	112	IR50×55×35-XL	0	-11
	58	22	0,6	115	IR50×58×22-XL	0	-11
	58	40	0,6	208	IR50×58×40-XL	0	-11
	60	25	1	162	IR50×60×25-XL	0	-11
	60	28	1,1	181	IR50×60×28-XL	0	-11
55	60	25	0,6	85,5	IR55×60×25-XL	-10	-21
	60	35	0,6	121	IR55×60×35-XL	-10	-21
	63	25	1	141	IR55×63×25-XL	-10	-21
	63	45	1	256	IR55×63×45-XL	-10	-21
	65	28	1,1	198	IR55×65×28-XL	-10	-21
	60	68	25	1	152	IR60×68×25-XL	-10
68		35	0,6	213	IR60×68×35-XL	-10	-21
68		45	1	276	IR60×68×45-XL	-10	-21
70		25	1	195	IR60×70×25-XL	-10	-21
70		28	1,1	215	IR60×70×28-XL	-10	-21
65		72	25	1	141	IR65×72×25-XL	-10
	72	45	1	259	IR65×72×45-XL	-10	-21
	73	25	1	164	IR65×73×25-XL	-10	-21
	73	35	1	231	IR65×73×35-XL	-10	-21
	75	28	1,1	229	IR65×75×28-XL	-10	-21
	70	80	25	1	221	IR70×80×25-XL	-10
80		30	1	267	IR70×80×30-XL	-10	-26
80		35	1	312	IR70×80×35-XL	-10	-26
80		54	1	488	IR70×80×54-XL	-10	-26

medias ▶ <https://www.schaeffler.de/std/1E82>





Inner rings

Without lubrication hole

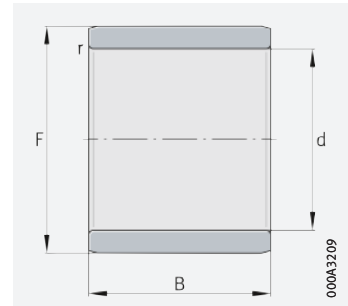

IR

000A3209

d = 75 – 380 mm

Main dimensions				Mass m ≈ g	Designation ▶995 3.5 ▶996 3.6 X-life ▶993	Deviations for raceway F	
d	F	B	r min.			upper μm	lower μm
75	85	25	1	238	IR75×85×25-XL	-4	-17
	85	30	1	287	IR75×85×30-XL	-4	-17
	85	35	1	336	IR75×85×35-XL	-4	-17
	85	54	1	520	IR75×85×54-XL	-4	-17
80	90	25	1	253	IR80×90×25-XL	-4	-17
	90	30	1	304	IR80×90×30-XL	-4	-17
	90	35	1	355	IR80×90×35-XL	-4	-17
	90	54	1	556	IR80×90×54-XL	-4	-17
85	95	26	1	277	IR85×95×26-XL	-14	-27
	95	36	1	388	IR85×95×36-XL	-14	-27
	100	35	1,1	582	IR85×100×35-XL	-14	-27
	100	63	1,1	1054	IR85×100×63-XL	-14	-27
90	100	26	1	294	IR90×100×26-XL	-14	-27
	100	30	1	340	IR90×100×30-XL	-14	-27
	100	36	1	406	IR90×100×36-XL	-14	-27
	105	35	1,1	610	IR90×105×35-XL	-14	-27
	105	63	1,1	1110	IR90×105×63-XL	-14	-27
95	105	26	1	313	IR95×105×26-XL	-14	-27
	105	36	1	431	IR95×105×36-XL	-14	-27
	110	35	1,1	657	IR95×110×35-XL	-14	-27
	110	63	1,1	1170	IR95×110×63-XL	-14	-27
100	110	30	1,1	350	IR100×110×30-XL	-14	-27
	110	40	1,1	505	IR100×110×40-XL	-14	-27
	115	40	1,1	797	IR100×115×40-XL	-14	-27
110	120	30	1	409	IR110×120×30-XL	-14	-32
	125	40	1,1	840	IR110×125×40-XL	-7	-22
120	130	30	1	442	IR120×130×30-XL	-7	-22
	135	45	1,1	1044	IR120×135×45-XL	-7	-22
130	145	35	1,1	855	IR130×145×35-XL	-17	-37
	150	50	1,5	1690	IR130×150×50-XL	-17	-37
140	155	35	1,1	917	IR140×155×35-XL	-17	-37
	160	50	1,5	1800	IR140×160×50-XL	-17	-37

medias ▶ <https://www.schaeffler.de/std/1E83>



Main dimensions				Mass m ≈ g	Designation ▶ 995 3.5 ▶ 996 3.6 X-life ▶ 993	Deviations for raceway F	
d	F	B	r min.			upper μm	lower μm
150	165	40	1,1	1 122	IR150×165×40-XL	-27	-52
160	175	40	1,1	1 200	IR160×175×40-XL	-27	-52
170	185	45	1,1	1 441	IR170×185×45-XL	-25	-46
180	195	45	1,1	1 510	IR180×195×45-XL	-25	-46
190	210	50	1,5	2 410	IR190×210×50-XL	-40	-66
200	220	50	1,5	2 518	IR200×220×50-XL	-40	-66
220	240	50	1,5	2 753	IR220×240×50-XL	-55	-86
240	265	60	2	4 600	IR240×265×60-XL	-55	-86
260	285	60	2	4 980	IR260×285×60-XL	-69	-107
280	305	69	2	6 100	IR280×305×69-XL	-69	-107
300	330	80	2,1	9 200	IR300×330×80-XL	-69	-107
320	350	80	2,1	9 800	IR320×350×80-XL	-83	-127
340	370	80	2,1	10 200	IR340×370×80-XL	-83	-127
360	390	80	2,1	10 900	IR360×390×80-XL	-128	-182
380	415	100	2,1	16 700	IR380×415×100-XL	-122	-172

medias ▶ <https://www.schaeffler.de/std/1E84>





Inner rings

With lubrication hole

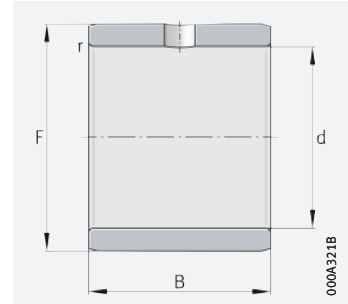

IR..-IS1

d = 6 – 50 mm

Main dimensions				Mass m ≈ g	Designation ▶ 995 3.5 ▶ 996 3.6 X-life ▶ 993	Deviations for raceway F	
d	F	B	r min.			upper μm	lower μm
6	10	10	0,3	3,7	IR6×10×10-IS1-XL	-7	-23
8	12	10	0,3	4,8	IR8×12×10-IS1-XL	-4	-18
10	14	12	0,3	7,3	IR10×14×12-IS1-XL	-4	-18
12	16	12	0,3	7,9	IR12×16×12-IS1-XL	-4	-18
15	20	12	0,3	12,2	IR15×20×12-IS1-XL	0	-12
20	25	16	0,3	24	IR20×25×16-IS1-XL	0	-12
25	30	16	0,3	25,7	IR25×30×16-IS1-XL	0	-12
30	38	20	0,6	77	IR30×38×20-IS1-XL	+5	-4
35	42	20	0,6	63,9	IR35×42×20-IS1-XL	0	-9
40	50	20	1	106	IR40×50×20-IS1-XL	0	-9
45	55	20	1	117	IR45×55×20-IS1-XL	0	-11
50	55	20	0,6	62,5	IR50×55×20-IS1-XL	0	-11
	60	20	1	128	IR50×60×20-IS1-XL	0	-11

medias ▶ <https://www.schaeffler.de/std/1E85>



Drawn cup roller clutches



1	Drawn cup roller clutches	1008
1.1	Product design	1008
1.2	Load carrying capacity	1010
1.3	Compensation of angular misalignments	1012
1.4	Lubrication	1012
1.5	Sealing	1012
1.6	Speeds	1013
1.7	Noise	1013



1.8	Temperature range	1013	1.15	Design of the adjacent construction	1015
1.9	Cages	1013	1.16	Mounting and dismounting	1019
1.10	Internal clearance	1013	1.17	Legal notice regarding data freshness	1020
1.11	Dimensions, tolerances	1014		Product tables	1021
1.12	Suffixes	1014		 Drawn cup roller clutches without bearing arrangement	1021
1.13	Structure of the product designation	1014		Drawn cup roller clutches with bearing arrangement	1022
1.14	Dimensioning	1014			



1 Drawn cup roller clutches



Drawn cup roller clutches:

- are one-way clutches, which transmit torques in one direction
▶ 1008 | 1
- are available with or without an integrated bearing arrangement
▶ 1009 | 2, ▶ 1010 | 3 and ▶ 1010 | 4
- give very precise indexing
- allow high indexing frequencies
- have a low overrunning frictional torque
- are available with or without greasing
- are particularly compact in a radial direction and therefore permit extremely compact designs
- are suitable for housing materials made from steel, light metal or plastic
- can be combined with drawn cup needle roller bearings with open ends HK and drawn cup needle roller bearings with closed end BK
- have an extensive range of applications, for example as indexing clutches, back-stopping clutches and overrunning clutches
▶ 1008 | 1.

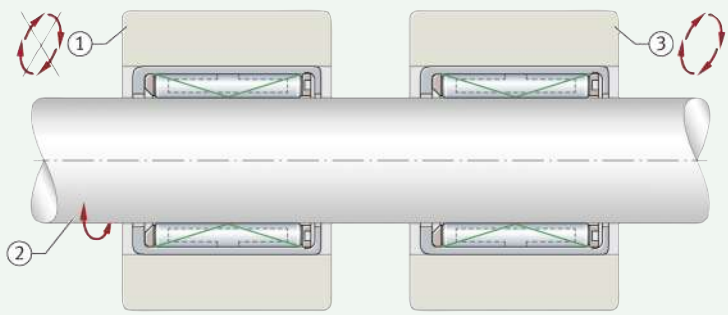
1
Drawn cup roller clutches
in tandem arrangement
in an indexing system

- ① Stationary component
- ② Component performs a swivel motion
- ③ Component performs a gradual rotational motion

1.1 Product design

Design variants

Drawn cup roller clutches are available:

- without bearing arrangement
▶ 1009 | 2
- with bearing arrangement (rolling or plain bearing)
▶ 1010 | 3 and ▶ 1010 | 4.

Drawn cup roller clutches are one-way clutches

Drawn cup roller clutches

These drawn cup roller clutches comprise thin-walled, drawn outer cups with a series of ramps on the inside diameter, plastic cages and needle rollers, which serve as clamping elements. Steel or plastic springs hold the needle rollers in their clamped position. Drawn cup roller clutches can transmit high torques in one direction and are particularly compact in a radial direction. The roller clutches are available with and without support bearing arrangements.

 Suitable for applications with high indexing frequencies

Drawn cup roller clutches give very precise indexing, since the individual spring loading of the needle rollers ensures continuous contact between the shaft, needle rollers and ramps. They allow high indexing frequencies due to their low mass and the resulting low moment of inertia of the clamping elements. They also have a low overrunning frictional torque.

 Preferred areas of application



Drawn cup roller clutches can be used in various applications such as indexing clutches, back-stopping clutches and overrunning clutches. In these cases, the drawn cup roller clutch performs an overrunning or locking function.



Drawn cup roller clutches should not be used if a malfunction could lead to personal injury. New applications, especially those involving extreme conditions, should first be verified by tests. Correct functioning can only be guaranteed if the concentricity error between the support bearing and the shaft can be kept to a low value.

Drawn cup roller clutches without bearing arrangement



 Suitable for supporting torques only

Roller clutches HF do not have a bearing arrangement, i.e. they transmit torques only and, as a result, are unable to support any radial forces  1009 |  2. In the case of these roller clutches, concentricity to the shaft axis must be secured by additional rolling bearings or drawn cup roller clutches with a bearing arrangement must be used. The drawn cup roller clutches are available with and without knurling.

 Drawn cup roller clutches without knurling

Drawn cup roller clutches without knurling are available with steel or plastic pressure springs  1009 |  2. Bearings with plastic springs have the suffix KF  1014 | 1.12.

 Drawn cup roller clutches with knurling

For improved torque transmission in plastic housings, drawn cup roller clutches are available with a knurled outside surface. These drawn cup roller clutches have the suffix R  1014 | 1.12. The knurling can be applied to part of the drawn cup or over its entire length. The drawn cup roller clutches are also available with steel or plastic pressure springs. Roller clutches with plastic springs have the suffix KF  1014 | 1.12.





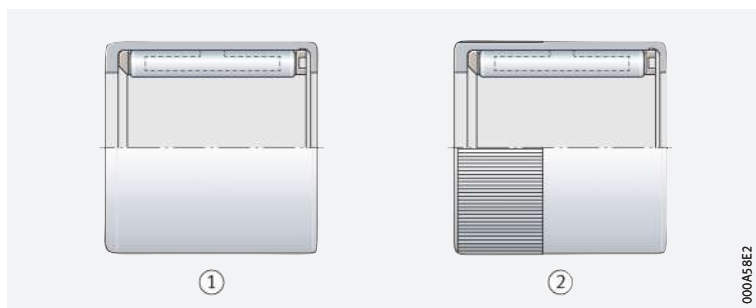

Drawn cup roller clutches without bearing arrangement, with and without knurling

- ① Without knurling
- ② With knurling







Drawn cup roller clutches with bearing arrangement



 Also suitable for supporting radial forces

Due to the integrated plain or rolling bearing, roller clutches HFL can also support radial forces in addition to torques  1010 |  3 and  1010 |  4. The drawn cup roller clutches are available with and without knurling.

 Drawn cup roller clutches without knurling

Drawn cup roller clutches without knurling are available with steel or plastic pressure springs  1010 |  3 and  1010 |  4. Drawn cup roller clutches with plastic springs have the suffix KF  1014 | 1.12.

 Drawn cup roller clutches with knurling

For improved torque transmission in plastic housings, drawn cup roller clutches are available with a knurled outside surface. These drawn cup roller clutches have the suffix R  1014 | 1.12. The knurling can be applied to part of the drawn cup or over its entire length. These drawn cup roller clutches are also available with steel or plastic pressure springs. Roller clutches with plastic springs have the suffix KF  1014 | 1.12.

3
Drawn cup roller clutches
with plain bearing arrangement,
with and without knurling

F_r = radial load

- ① Without knurling
- ② With knurling
- ③ Plain bearing

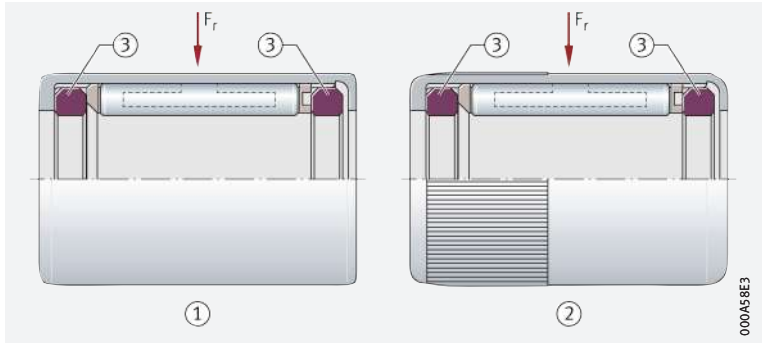

4
Drawn cup roller clutch
with rolling bearing arrangement,
without knurling

F_r = radial load

- ① Rolling bearing

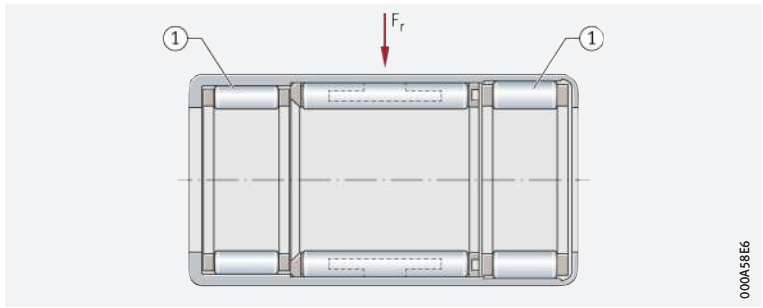

Clamping direction of the drawn cup roller clutch



An arrow on the end face of the drawn cup indicates the clamping direction of the drawn cup roller clutch. The roller clutch clamps when the drawn cup is rotated in the direction of the arrow.

1.2 Load carrying capacity

Roller clutches with a support bearing arrangement accommodate radial forces

Depending on the design (with or without bearing arrangement), drawn cup roller clutches can either transmit torques only or additional radial loads $\blacktriangleright 1008$ | 1.1, $\blacktriangleright 1010$ | ③ and $\blacktriangleright 1010$ | ④.

For roller clutches without bearing arrangement, radial forces must be supported by additional bearings.

The rigidity of the housing determines the transmissible torque

Transmissible torque

Transmission of torque requires a rigid housing. The transmissible torque is therefore dependent on the shaft and housing material, the shaft hardness, the wall thickness of the housing and the shaft and housing tolerances. When calculating the torque, the maximum drive torque and the moment of inertia of the masses during acceleration must be taken into consideration.

Do not exceed the limiting load

Limiting load

In the case of drawn cup roller clutches with plain bearings, the product calculated from the actual speed n and radial load F_r must not exceed the value stated for the limiting load $(F_r \cdot n)_{max}$. The operating limits are determined by the limiting speeds stated in the product tables and the permissible radial load.

The roller clutch must not be overloaded

Indexing accuracy and indexing frequency

In order not to overload the clutch, the inertia of the entire system must be taken into consideration. The high indexing accuracy is due to the individual spring loading of the needle rollers, which ensures continuous contact between the shaft, needle rollers and clamping surface.

The indexing accuracy is influenced by the indexing frequency, lubrication, fitting tolerances, adjacent construction, elastic deformation of the adjacent parts and the drive method, either through the shaft or the housing. Optimum accuracy is achieved if the drive is via the shaft.

High indexing frequencies due to low mass

High indexing frequencies are due to the low mass and the resulting low moment of inertia of the clamping elements.

Frictional torque and frictional energy

For pattern of frictional torque \blacktriangleright 1011 | ⊞ 5. The overrunning frictional energy at idle is dependent on whether the shaft or the outer ring is rotating \blacktriangleright 1011 | ⊞ 6.

5
Overrunning frictional torque, as a function of shaft diameter

M_R = overrunning frictional torque
 d = shaft diameter

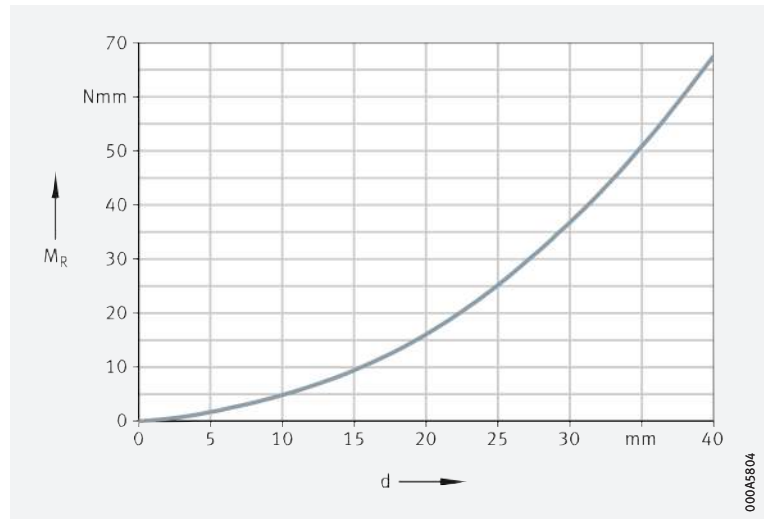

6
Overrunning frictional energy, as a function of speed

N_R = overrunning frictional energy
 n = speed
 n_{GA} = limiting speed with rotating outer ring
 n_{GW} = limiting speed with rotating shaft

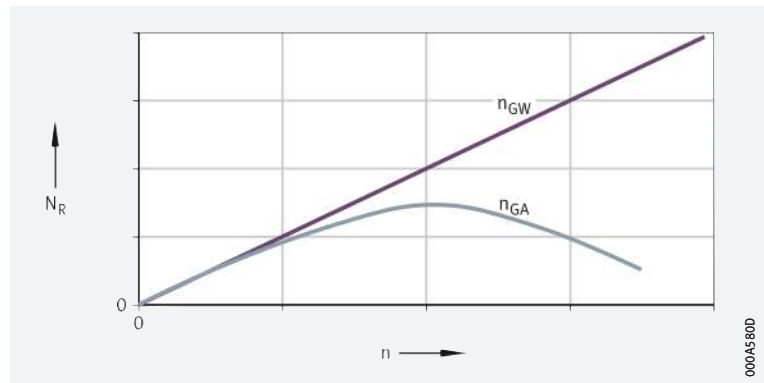

Rotating outer ring

Due to the centrifugal force, the needle rollers may lift off the shaft

If the outer ring rotates, the frictional energy increases with speed at first but then, due to the centrifugal force of the needle rollers, it decreases gradually towards zero. At this speed, there is no longer any frictional contact between the needle rollers and the shaft. Due to the increasing centrifugal force, the needle rollers lift off the shaft.

1.3 Compensation of angular misalignments



Concentricity is an essential precondition for correct functioning of the roller clutch. Correct functioning can only be guaranteed if the concentricity error between the support bearing and the shaft can be kept to a low value.

1.4 Lubrication

A grease to GA26 is used for initial greasing

The roller clutches are greased using a lithium soap grease to GA26. In many cases, the initial greasing is sufficient to last the operating life of the bearings. For applications with oil lubrication, roller clutches are available without greasing. These roller clutches are coated with a preservative. For general applications (mixed operation involving locking and overrunning), the Schaeffler initial greasing has proved effective. In order to ensure optimum function, it may be necessary to use different lubricants. The suitability of the lubricant must then be verified by means of tests.



For applications in which one operating condition (overrunning or locking) is heavily predominant, a special greasing should be used. In this case, please consult Schaeffler.

A grease operating life cannot be calculated

It is not possible to calculate the grease operating life or lubrication interval for drawn cup roller clutches. If relubrication is carried out, oil should be used for lubrication or a changeover to oil lubrication should generally be made. At temperatures $< -10\text{ }^{\circ}\text{C}$ and speeds $> 0,7\text{ }n_G$, recommendations on lubrication should be requested. At temperatures over $+70\text{ }^{\circ}\text{C}$, oil lubrication should be used. The oil level should be such that, when the drawn cup roller clutch is stationary and the axis is horizontal, it is immersed approx. $\frac{1}{3}$ in the oil bath.

Suitable lubricating oils

Suitable oils are CL and CLP to DIN 51517 or HL and HLP to DIN 51524. Viscosity classes **▶ 1012** 1.

Compatibility with plastic cages

When using bearings with plastic cages, compatibility between the lubricant and the cage material must be ensured if synthetic oils, lubricating greases with a synthetic oil base or lubricants containing a high proportion of EP additives are used.

1
 Viscosity classes

Operating temperature °C		Viscosity class
from	to	
+15	+30	ISO VG 10
+15	+90	ISO VG 32
+60	+120	ISO VG 100

1.5 Sealing

Drawn cup roller clutches (with and without bearing arrangement) are supplied without seals. Contaminants (dust, dirt and moisture) can impair the function and operating life of roller clutches.

Sealing of the bearing position with sealing rings G or SD

Effective sealing elements for use in sealing open drawn cup roller clutches with a risk of contamination

If there is a risk of contamination, sealing rings of economical series G or SD should be fitted **▶ 1026**. The sealing rings are designed as contact seals and are arranged in front of the roller clutch. They protect the bearing position reliably against contamination, spray water and excessive loss of grease. The sealing rings are matched to the small radial dimensions of the drawn cup roller clutches and can be combined with wider inner rings of series IR. They are very easy to fit, since they are simply pressed into the housing bore.

1.6 Speeds

 *Speeds for rotating shaft or rotating outer ring*

The limiting speeds n_{GW} and n_{GA} in the product tables are valid for oil and grease lubrication. The limiting speed n_{GW} is valid for a rotating shaft, while n_{GA} is valid for a rotating outer ring.

1.7 Noise

Schaeffler Noise Index

The Schaeffler Noise Index (SGI) is not yet available for this bearing type ►69. The data for these bearing series will be introduced and updated in stages.

Further information:

■ **medias** ► <https://medias.schaeffler.com>.

1.8 Temperature range

Possible operating temperatures of drawn cup roller clutches
►1013|2.

2
Permissible temperature ranges

Operating temperature	Drawn cup roller clutches
	-10 °C to +70 °C, limited by the lubricant





In the event of anticipated temperatures which lie outside the stated values, please contact Schaeffler.

1.9 Cages

Plastic cages are used in the guidance of rolling elements for roller clutches and for integrated support bearing arrangements supported by rolling elements.

1.10 Internal clearance

 *The enveloping circle diameter F_w applies instead of the radial internal clearance*

In the case of bearings without inner ring, the dimension for the enveloping circle diameter F_w is used instead of the radial internal clearance. The enveloping circle is the inner inscribed circle of the needle rollers in clearance-free contact with the outer raceway. In drawn cup roller clutches with a rolling bearing arrangement, the enveloping circle diameter F_w of the bearings once fitted (in the solid section ring gauge) is approximately in tolerance class F8. Upper and lower deviations of enveloping circle diameter for tolerance class F8 ►1013|3.

3
Deviations of enveloping circle diameter for drawn cup roller clutches supported by rolling bearings

Enveloping circle diameter F_w mm		Tolerance class F8 Tolerance for enveloping circle diameter F_w	
over	incl.	upper deviation μm	lower deviation μm
3	6	+28	+10
6	10	+35	+13
10	18	+43	+16
18	30	+53	+20
30	50	+64	+25

1.11 Dimensions, tolerances

Dimensions and tolerances of drawn cup roller clutches are not standardised. The thin-walled outer cups adopt the dimensional and geometrical accuracy of the housing bore.

1.12 Suffixes

For a description of the suffixes used in this chapter ▶ 1014 | 4 and **medias** interchange ▶ <https://www.schaeffler.de/std/1D52>.

4
Suffixes and corresponding descriptions

Suffix	Description of suffix	
–	Steel springs	Standard
KF	Plastic pressure springs	
R	Knurled outside surface	
RR	Drawn cup roller clutch with Corrotect coating	Special design, available by agreement

1.13 Structure of the product designation

Examples of composition of product designation

The designation of drawn cup roller clutches follows a set model. Examples ▶ 1014 | 7 and ▶ 1014 | 8.

7
Drawn cup roller clutch without bearing arrangement, without knurling: designation structure

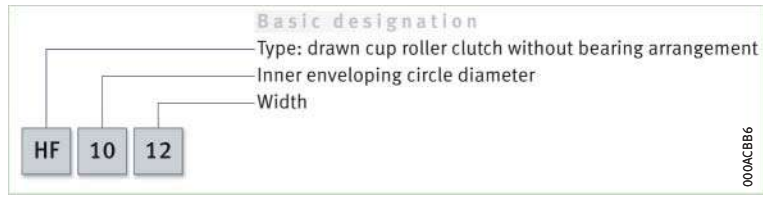

8
Drawn cup roller clutch with bearing arrangement, plastic pressure springs, with knurling: designation structure

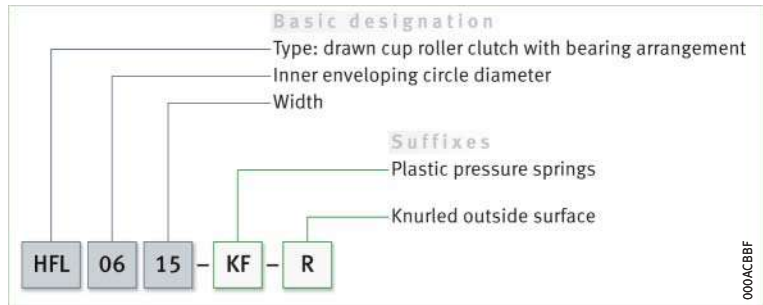

1.14 Dimensioning

The size is determined on the basis of the load carrying capacity of the drawn cup roller clutch relative to the loads and the requirements for rating life and operational reliability ▶ 1015 | 1.15.

1.15 Design of the adjacent construction

Design of housing bore

☞ *Support outer cup over entire circumference and width*

Suitable housing materials are steel, light metal or plastic. In order to allow full utilisation of the performance capability of drawn cup roller clutches and achieve the requisite rating life, sufficient rigid support must be provided for the outer cups in the housing. The support for the outer cup in the housing bore can be produced as a cylindrical seating surface. The seating surfaces for the outer cup and the raceway for the rolling elements or inner ring (if the bearing arrangement is not produced as a direct bearing arrangement) should not be interrupted by grooves, holes or other recesses. The accuracy of the mating parts must meet specific requirements, the bore tolerances for the housing bore (recommended tolerance classes) are dependent on the housing material ▶ 1015 | 5 and ▶ 1016 | 6. The surface quality of the housing bore should be Ramax 0,8. The cylindricity tolerance of the housing bore in metal housings should be within the tolerance grade IT5/2.



Due to the thin-walled outside surface, the roller clutches only adopt their precise geometry once they have a tight fit. As a result, the accuracy of the locating bore essentially determines the geometrical accuracy of the drawn cup and thus the functioning of the clutch.

☞ *Provide lead chamfer on the housing bore*

For the drawn cup roller clutches to be mounted without damage, the housing bore must have a lead chamfer of 15°.



5 Design of housing bore

Series	Springs	Bore		
		Housing material		
		Steel Cast iron	Light metal	Max. bore in plastic ²⁾
HF, HFL	Steel	N6 Ⓞ (N7 Ⓞ) ¹⁾	R6 Ⓞ (R7 Ⓞ) ¹⁾	–
HF..KF, HFL..KF	Plastic	N7 Ⓞ	R7 Ⓞ	–
HF..R, HFL..R	Steel	–	–	0 D –0,05
HF..KF-R, HFL..KF-R	Plastic	–	–	0 D –0,05
HFL0606-KF-R, HFL0806-KF-R	Plastic	–	–	0 D –0,05

1) The values in brackets can be used if the actual torque is no more than 50% of the permissible torque $M_{d\text{per}}$ in accordance with the product table.

2) Guide values as a function of the plastic used. Outside diameter D ▶ 1021 | 6.

Maximum transmissible torque

Minimum wall thickness for metal housings

For metal housings, the maximum transmissible torque $M_{d\ per\ max}$ is determined as a function of the diameter ratio Q_A to **▶ 1016** | **9** (steel housing) or to **▶ 1017** | **10** (aluminium housing), see calculation examples. Guide values for $Q_{A\ max}$ with steel and aluminium as housing materials **▶ 1016** | **6**.

6
 Guide values

Housing material	Diameter ratio $Q_{A\ max}$
Steel	0,8
Aluminium	0,6



The comparative stress σ_v must not exceed the yield stress of the housing material.

Calculation example

Steel housing

For drawn cup roller clutches HF0612, the maximum transmissible torque $M_{d\ per\ max}$ should be determined **▶ 1016** | **9**:

- Drawn cup roller clutch HF0612
- Housing Steel
- Housing bore tolerance N6 **▶ 1015** | **5**
- Permissible housing stress ($R_{p0,2}$) σ_v 450 N/mm²
- Diameter ratio Q_A of housing 0,9
- Permissible torque $M_{d\ per}$ in accordance with product table

Calculation

$$\begin{aligned}
 M_{d\ per\ max} &= 60\% M_{d\ per} \\
 &= 0,6 \cdot 1,76\ \text{Nm} \\
 &= 1,056\ \text{Nm}
 \end{aligned}$$

9
 Steel housing

Modulus of elasticity
 $E = 210\ 000\ \text{N/mm}^2$

- Q_A = diameter ratio of housing
- D_{Ai} = housing bore
- D_{Aa} = housing outside diameter
- $M_{d\ per}$ = permissible torque
- $M_{d\ per\ max}$ = maximum transmissible torque
- σ_v = comparative stress

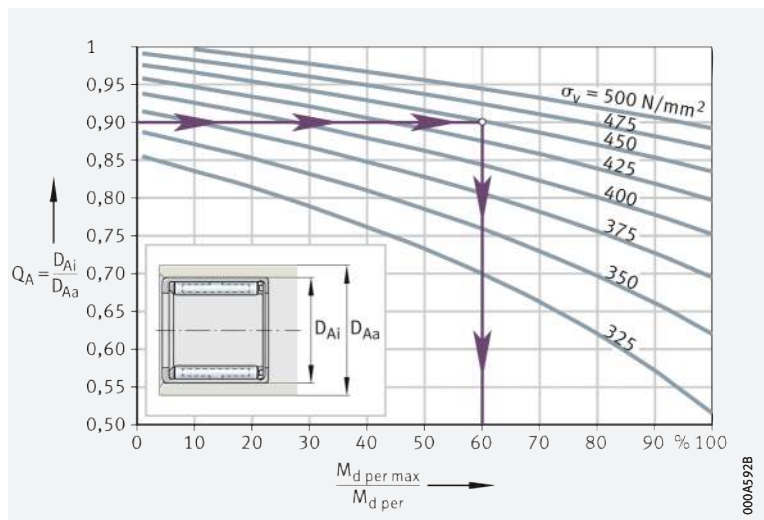

🔗 Calculation example

Aluminium housing

For drawn cup roller clutch HF1616, the diameter ratio Q_A of the housing should be determined ▶ 1017 | 10:

Drawn cup roller clutch	HF1616
Housing	Aluminium
Housing bore tolerance	R6 Ⓢ ▶ 1015 5
Permissible housing stress ($R_{p0,2}$) σ_v	250 N/mm ²
Maximum transmissible torque $M_{d \text{ per max}}$	10 Nm
Permissible torque $M_{d \text{ per}}$	in accordance with product table
giving $M_{d \text{ per max}}/M_{d \text{ per}}$	50%

🔗 Calculation

$$Q_A = D_{Ai}/D_{Aa} \leq 0,7$$

$$D_{Aa} \geq D_{Ai}/0,7 = 22 \text{ mm}/0,7$$

$$= 31,5 \text{ mm}$$

10

Aluminium housing

Modulus of elasticity
 $E = 70\,000 \text{ N/mm}^2$

Q_A = diameter ratio of housing

D_{Ai} = housing bore

D_{Aa} = housing outside diameter

$M_{d \text{ per}}$ = permissible torque

$M_{d \text{ per max}}$ = maximum transmissible torque

σ_v = comparative stress

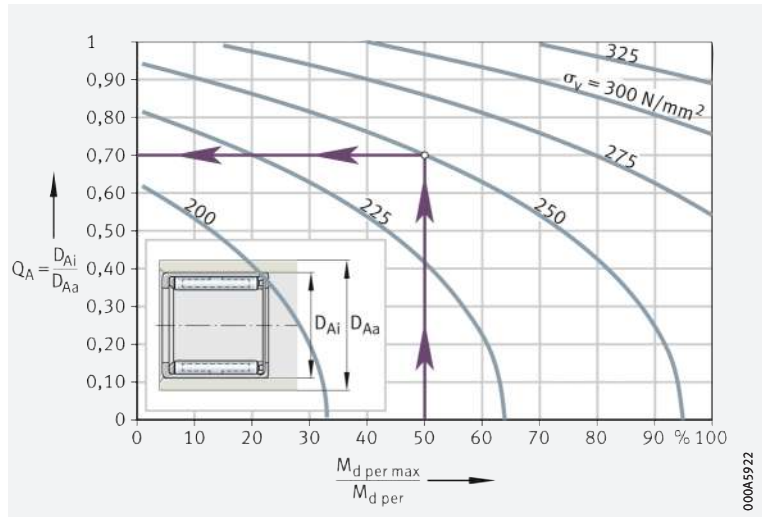

000A592Z

Minimum wall thickness for plastic housings



For plastic housings, drawn cup roller clutches with a partially or fully knurled outside surface should be used (suffix R).

The guide value for the minimum wall thickness of plastic housings is:

f_1

$$s_{\min} \geq D - F_w$$

Legend

s_{\min}	mm	Minimum wall thickness
D	mm	Outside diameter of roller clutch
F_w	mm	Enveloping circle.

Axial location

A tight fit is usually sufficient for axial location

Drawn cup roller clutches give very easy mounting and permit simple adjacent constructions. The drawn cup roller clutches are pressed into the housing bore and require no further axial location.

The precondition for this is, however, that the specifications in accordance with $\blacktriangleright 1015$ | $\square 5$ are observed.

Design of the shaft/raceway

Produce the raceway as a rolling bearing raceway

Drawn cup roller clutches HF/HFL are usually used without an inner ring. In order to guarantee correct functioning of the drawn cup roller clutches, the raceway for the rolling elements on the shaft must be produced as a rolling bearing raceway (hardened and ground). The surface hardness of the raceways must be 670 HV to 840 HV, the case hardening depth CHD must be sufficiently large ($CHD \geq 0,3$ mm). Design of raceways $\blacktriangleright 1018$ | $\square 7$. If the shaft cannot be produced as a raceway, the bearings can be combined with inner rings IR or LR.

Provide lead chamfer on the shaft

For the bearings to be mounted without damage, the shaft must have a lead chamfer of 10° to 15° with a width of approx. 1 mm.

$\square 7$
 Design of shaft

Series	Springs	Shaft			
		Tolerance class ¹⁾	Roundness tolerance	Parallelism tolerance	Recommended mean roughness value R _{max} (R _{zmax}) μm
HF, HFL	Steel	h5 (h6) ²⁾	IT3	IT3	0,4 (2)
HF..-KF, HFL..-KF	Plastic	h8			
HF..-R, HFL..-R	Steel	h5 (h6) ²⁾	IT3	IT3	0,4 (2)
HF..-KF-R, HFL..-KF-R	Plastic	h8			
HFL0606-KF-R, HFL0806-KF-R	Plastic	h9			

¹⁾ The envelope requirement © applies.

²⁾ The values in brackets can be used if the actual torque is no more than 50% of the permissible torque M_d per

1.16 Mounting and dismounting



Protect drawn cup roller clutches against dust, dirt and moisture; contaminants can impair the function and operating life of roller clutches. Pressing-in forces must never be directed through the rolling elements. Drawn cup roller clutches must not be tilted during pressing-in, as this may damage the needle rollers and raceways.

Retention for transport

Drawn cup roller clutches are normally packed individually in the case of small quantities. Where larger quantities are involved, drawn cup roller clutches are placed in a specific orientation in blister packaging and delivered in this form. The blister packaging then serves to retain the parts in position during transport.

Removing the drawn cup roller clutches from the packaging

Drawn cup roller clutches should only be removed from their original packaging immediately before assembly. If roller clutches are removed from a batch packaged with dry preservative, the package must be closed again immediately. The protective vapour phase can be maintained only in the closed package. Ungreased drawn cup roller clutches are coated with a preservative. Lubrication with oil must take place after pressing-in, in accordance with the specifications.

Storage

Drawn cup roller clutches should be stored:

- in dry, clean rooms with the room temperature as constant as possible
- at a relative humidity of max. 65%.

Storage period

The storage period for greased drawn cup roller clutches is limited by the shelf life of the lubricating grease.

Mounting using a fitting mandrel

Drawn cup roller clutches should only be pressed into the locating bore using a special fitting mandrel. Attention must be paid to the clamping direction of the roller clutch. The clamping direction is indicated by an arrow on the end face of the drawn cup.

The drawn cup roller clutch clamps if it is rotated in the direction of the arrow.

Functional inspection

Clutches without knurling

The function of these roller clutches is checked in a housing with the minimum wall thickness determined according to ►1016|9 or thicker. The housing bore and shaft tolerances must be observed ►1015|5 and ►1018|7.

Clutches with knurling

The function of these clutches is checked before they are pressed in. In this case, the inspection criteria are the clamping effect and idling.



For any questions relating to the mounting of drawn cup roller clutches, please consult Schaeffler.

Schaeffler Mounting Handbook

Drawn cup roller clutches must be handled with great care

In order that drawn cup roller clutches can function correctly and achieve the envisaged operating life without detrimental effect, they must be handled with care.



The Schaeffler Mounting Handbook MH 1 gives comprehensive information about the correct storage, mounting, dismounting and maintenance of rotary rolling bearings ►<https://www.schaeffler.de/std/1D53>.

It also provides information which should be observed by the designer, in relation to the mounting, dismounting and maintenance of bearings, in the original design of the bearing position. This book is available from Schaeffler on request.

1.17

Legal notice regarding data freshness

The further development of products may also result in technical changes to catalogue products

Of central interest to Schaeffler is the further development and optimisation of its products and the satisfaction of its customers. In order that you, as the customer, can keep yourself optimally informed about the progress that is being made here and with regard to the current technical status of the products, we publish any product changes which differ from the printed version in our electronic product catalogue.



We therefore reserve the right to make changes to the data and illustrations in this catalogue. This catalogue reflects the status at the time of printing. More recent publications released by us (as printed or digital media) will automatically precede this catalogue if they involve the same subject. Therefore, please always use our electronic product catalogue to check whether more up-to-date information or modification notices exist for your desired product.

Link to electronic product catalogue



The following link will take you to the Schaeffler electronic product catalogue: ► <https://medias.schaeffler.com>.



Drawn cup roller clutches

Without bearing arrangement
With or without knurling

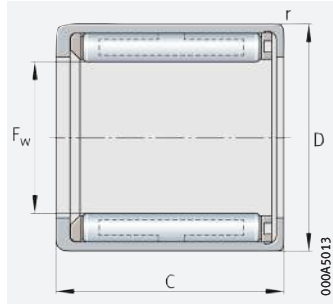

HF, HF..-KF
Without knurling

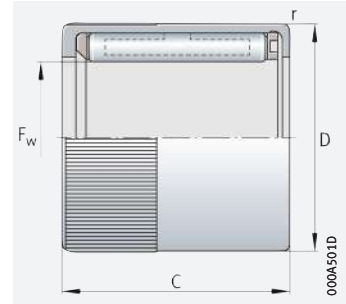

HF..-R, HF..-KF-R
With knurling

$F_w = 3 - 35 \text{ mm}$

Main dimensions				Permissible torque M_d per Nm	Limiting speeds		Mass m ≈ g	Designation ▶ 1014 1.12 ▶ 1014 1.13		Suitable drawn cup needle roller bearings for radial support ▶ 886
F_w	D	C -0,3	r min.		$n_{GW}^{1)}$ min ⁻¹	$n_{GA}^{2)}$ min ⁻¹		Drawn cup roller clutch with plastic springs	steel springs	
3	6,5	6	0,3	0,18	45 000	8 000	1	HF0306-KF	–	HK0306-TV
	6,5	6	0,3	0,06	45 000	8 000	1	HF0306-KF-R	–	HK0306-TV
4	8	6	0,3	0,34	34 000	8 000	1	HF0406-KF	–	HK0408
	8	6	0,3	0,1	34 000	8 000	1	HF0406-KF-R	–	HK0408
6	10	12	0,3	1,76	23 000	13 000	3	HF0612-KF	HF0612	HK0608
	10	12	0,3	0,6	23 000	13 000	3	HF0612-KF-R	HF0612-R	HK0608
8	12	12	0,3	3,15	17 000	12 000	3,5	HF0812-KF	HF0812	HK0808
	12	12	0,3	1	17 000	12 000	3,5	HF0812-KF-R	HF0812-R	HK0808
10	14	12	0,3	5,3	14 000	11 000	4	HF1012-KF	HF1012	HK1010
12	18	16	0,3	12,2	11 000	8 000	11	–	HF1216	HK1212
14	20	16	0,3	17,3	9 500	8 000	13	–	HF1416	HK1412
16	22	16	0,3	20,5	8 500	7 500	14	–	HF1616	HK1612
18	24	16	0,3	24,1	7 500	7 500	16	–	HF1816	HK1812
20	26	16	0,3	28,5	7 000	6 500	17	–	HF2016	HK2010
25	32	20	0,3	66	5 500	5 500	30	–	HF2520	HK2512
30	37	20	0,3	90	4 500	4 500	36	–	HF3020	HK3012
35	42	20	0,3	121	3 900	3 900	40	–	HF3520	HK3512

medias ▶ <https://www.schaeffler.de/std/1E86>

¹⁾ Limiting speed for rotating shaft.

²⁾ Limiting speed for rotating outer ring.



Drawn cup roller clutches

With bearing arrangement
With or without knurling

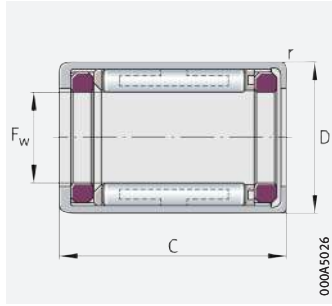

HFL, HFL...-KF, plain bearing arrangement (HFL0308-KF, HFL0408-KF, HFL0615-KF, HFL0615)

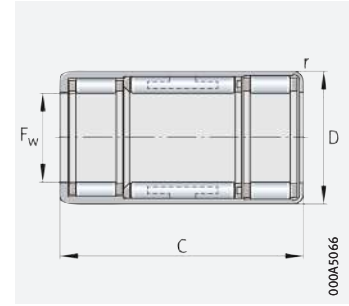

HFL, HFL...-KF, rolling bearing arrangement ($F_w \geq 8$ mm and $C \geq 22$ mm), HFL0822-KF-R, HFL0822-R

$F_w = 3 - 35$ mm

Main dimensions				Basic load ratings ¹⁾		Fatigue limit load C_{ur} N	Permissible torque M_d per Nm	Limiting speeds		Mass m ≈ g
F_w	D	C	r	dyn. C_r N	stat. C_{0r} N			n_{GW} ³⁾ min ⁻¹	n_{GA} ⁴⁾ min ⁻¹	
3	6,5	8	0,3	–	–	–	0,18	45 000	8 000	1,4
	6,5	8	0,3	–	–	–	0,06	45 000	8 000	1,4
4	8	8	0,3	–	–	–	0,34	34 000	8 000	1,6
	8	8	0,3	–	–	–	0,1	34 000	8 000	1,6
6	10	6	0,3	–	–	–	0,5	23 000	13 000	1
	10	15	0,3	–	–	–	1,76	23 000	13 000	4
	10	15	0,3	–	–	–	0,6	23 000	13 000	4
8	12	6	0,3	–	–	–	0,7	17 000	12 000	2
	12	22	0,3	3 650	3 950	550	3,15	17 000	12 000	7
	12	22	0,3	3 650	3 950	550	1	17 000	12 000	7
10	14	22	0,3	3 950	4 500	630	5,3	14 000	11 000	8
12	18	26	0,3	6 300	6 700	920	12,2	11 000	8 000	18
14	20	26	0,3	6 800	7 800	1 080	17,3	9 500	8 000	20
16	22	26	0,3	7 400	9 000	1 250	20,5	8 500	7 500	22
18	24	26	0,3	8 000	10 200	1 420	24,1	7 500	7 500	25
20	26	26	0,3	8 500	11 400	1 590	28,5	7 000	6 500	27
25	32	30	0,3	10 600	14 000	1 900	66	5 500	5 500	44
30	37	30	0,3	11 600	16 900	2 290	90	4 500	4 500	51
35	42	30	0,3	12 200	18 800	2 550	121	3 900	3 900	58

medias ► <https://www.schaeffler.de/std/1E87>

- 1) Drawn cup roller clutches with rolling bearing arrangement.
- 2) Drawn cup roller clutches with plain bearing arrangement: during operation, the product calculated from the actual speed n and radial load F_r must not exceed the value stated for the limiting load $(F_r \cdot n)_{max}$. The operating limits are determined by the limiting speeds stated and the permissible radial load.
- 3) Limiting speed for rotating shaft.
- 4) Limiting speed for rotating outer ring.
- 5) No arrow on end face.

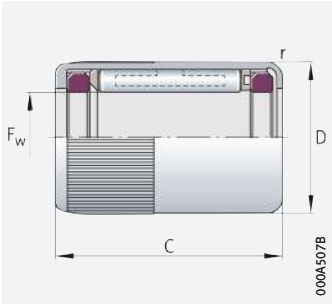

HFL0308-KF-R, HFL0408-KF-R,
HFL0615-R, HFL0615-KF-R, plain
bearing arrangement, with knurling

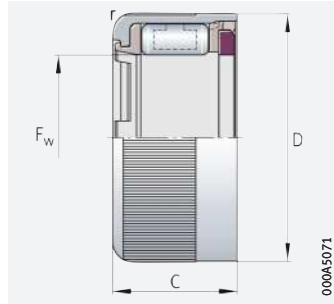

HFL0606-KF-R⁵⁾, HFL0806-KF-R⁵⁾,
plain bearing arrangement,
with knurling

F_w	Designation ▶ 1014 1.12 ▶ 1014 1.13		Permissible radial load ²⁾ $F_{r \max}$ N	Limiting load ($F_r \cdot n$) _{max} ²⁾ N/min
	Drawn cup roller clutch with plastic springs	steel springs		
3	HFL0308-KF	–	60	16 000
	HFL0308-KF-R	–	60	16 000
4	HFL0408-KF	–	80	16 000
	HFL0408-KF-R	–	80	16 000
6	HFL0606-KF-R	–	40	4 200
	HFL0615-KF	HFL0615	110	18 000
	HFL0615-KF-R	HFL0615-R	110	18 000
8	HFL0806-KF-R	–	54	4 200
	HFL0822-KF	HFL0822	–	–
	HFL0822-KF-R	HFL0822-R	–	–
10	–	HFL1022	–	–
12	–	HFL1226	–	–
14	–	HFL1426	–	–
16	–	HFL1626	–	–
18	–	HFL1826	–	–
20	–	HFL2026	–	–
25	–	HFL2530	–	–
30	–	HFL3030	–	–
35	–	HFL3530	–	–

Sealing rings



1	Sealing rings	1026
1.1	Product design	1026
1.2	Lubrication	1031
1.3	Temperature range	1031
1.4	Suffixes	1032
1.5	Structure of the product designation	1032



- 1.6 Design of bearing arrangements _____ 1032
- 1.7 Mounting and dismounting _____ 1033
- 1.8 Legal notice regarding
data freshness _____ 1035

Product tables

-  *Sealing rings* _____ 1036



1 Sealing rings



The sealing rings:

- are of a single lip or double lip design
▶ 1027 | 2, ▶ 1027 | 3, ▶ 1028 | 4
- are used as contact type sealing elements for sealing of the bearing position in the adjacent construction ▶ 1026 | 1
- are also suitable as wipers where purely axial motion is present
- protect the bearings against contamination, spray water and the loss of grease
- are resistant to undoped lubricants with a mineral oil base
- allow circumferential speeds at the seal lip of up to 10 m/s, depending on the surface quality of the shaft
- are matched to the radial dimensions of Schaeffler drawn cup needle roller bearings and needle roller bearings ▶ 1026 | 1
- are easy to fit, since they are simply pressed into the housing bore.



Sealing of the bearing position by a Schaeffler sealing ring

- ① Single lip sealing ring G
- ② Needle roller bearing NK
- ③ Inner ring LR

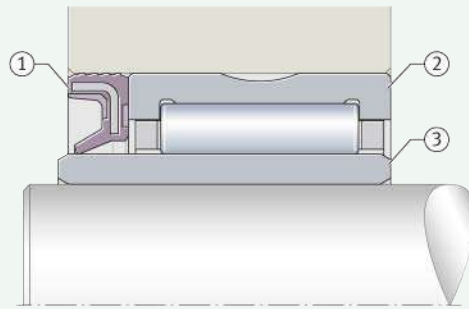

1.1 Product design

Design variants

Sealing rings are available as:

- a single lip variant (sealing ring GR and G)
▶ 1027 | 2 and ▶ 1027 | 3
- a double lip design (sealing ring SD)
▶ 1028 | 4.

Sealing of the bearing position has a decisive influence on the function and operating life of a bearing

The quality of a bearing arrangement is decisively influenced by the components – shaft, housing, seal – that are directly adjacent to the bearing. Seals play a decisive role in protecting bearings against contamination. If inadequate seals are used, contaminants can penetrate the bearing or an unacceptably large quantity of lubricant may escape from the bearing. Solid contaminants lead to wear and/or fatigue of the raceways and rolling elements. Bearings that are contaminated or running dry will fail long before they reach their fatigue rating life. In the design of bearing arrangements, the use of the correct seals is therefore decisive in determining the operating life of the bearings and the cost-effectiveness of the bearing arrangement.

Schaeffler sealing rings G, GR, SD

Schaeffler sealing rings were developed as seals for needle roller bearings and have been available in the market for decades. During this time, they have proved extremely effective in automotive and engine construction as well as machine and equipment building.



Fundamental information on sealing rings and the principles of sealing ring technology as well as examples of applications are given in Technical Product Information TPI 128. This publication can be requested from Schaeffler.

Single lip sealing rings

☞ *With external steel reinforcement or rubber encased reinforcing ring*

Single lip sealing rings are available in the designs GR and G ▶1027|☐2, ▶1027|☐3 and ▶1028|■1. The sealing rings comprise a high quality synthetic NBR elastomer material, which is coloured green.

Due to an active filler material, the sealing rings have particularly good resistance to wear and heat.

☞ *Sealing rings GR*

Sealing rings GR suitable for shaft diameters up to 7 mm as standard and have external steel reinforcement for stiffening purposes ▶1027|☐2 and ▶1028|■1.

☞ *Sealing rings G*

Sealing rings G are designed for shaft diameters over 8 mm and have a rubber encased steel reinforcement with a rubber wave profile for stiffening purposes ▶1027|☐3 and ▶1028|■1. This provides good sealing on the outside diameter. At the same time, it also reduces the forces required for fitting.



The angled reinforcing rings are made from formed sheet steel in accordance with DIN 1623 or DIN 1624 respectively.

☐2
Single lip sealing ring GR

- ① Angled reinforcing ring
- ② Back surface (with marking)
- ③ Contact surface
- ④ Back face
- ⑤ End face
- ⑥ Seal edge
- ⑦ Seal lip
- ⑧ End surface
- ⑨ Outside surface

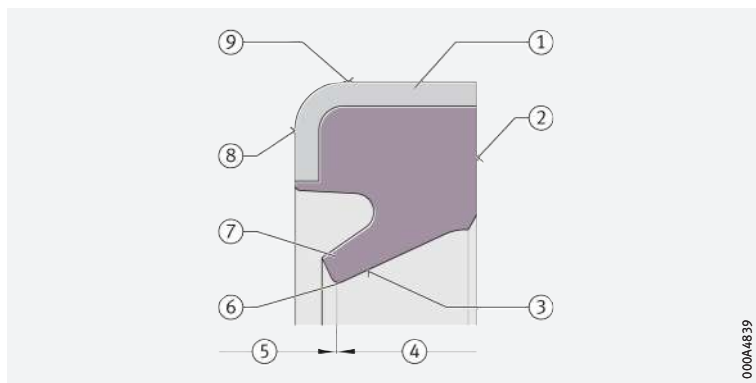

000A4839

☐3
Single lip sealing ring G

- ① Outside surface
- ② Rubber casing
- ③ Angled reinforcing ring
- ④ Back surface (with marking)
- ⑤ Contact surface
- ⑥ Back face
- ⑦ End face
- ⑧ Seal edge
- ⑨ Seal lip
- ⑩ Locating recess
- ⑪ End surface

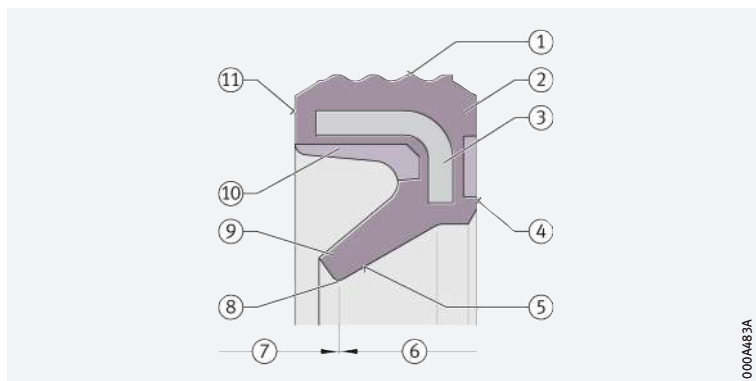

000A483A

Double lip sealing rings

☞ *With contact lip and non-contact dust shield*

Double lip sealing rings are available in the design SD ▶1028|☐4 and ▶1028|■1:

- A contact seal lip essentially prevents the escape of lubricant and unpressurised oil from the bearing arrangement.
- A protective lip in contact with the shaft (marked side) also acts as a gap seal against the ingress of contamination.



The space between the seal lip and protective lip must be filled with grease.

- ✎ *Carrier and lip area made from different materials*
- ✎ *Also suitable as wipers on shaft with axial motion*

The sealing rings comprise two plastic components: the carrier is made from glass fibre reinforced polyamide PA66-GF, while the seal lip area is made from thermoplastic PU elastomer (coloured green).

Sealing rings SD can also be used as wipers on shafts with axial motion. Since these sealing rings are made from a harder and stiffer lip material than the sealing rings G and also have an additional protective lip, they are particularly suitable for axial motions. Stroke velocities up to 3 m/s are possible, depending on the surface quality of the shaft.

4
Double lip sealing ring SD

- ① Outside surface
- ② Carrier
- ③ Back surface (with marking)
- ④ Protective lip
- ⑤ Membrane
- ⑥ Back face
- ⑦ End face
- ⑧ Seal contact surface
- ⑨ Seal lip
- ⑩ End surface

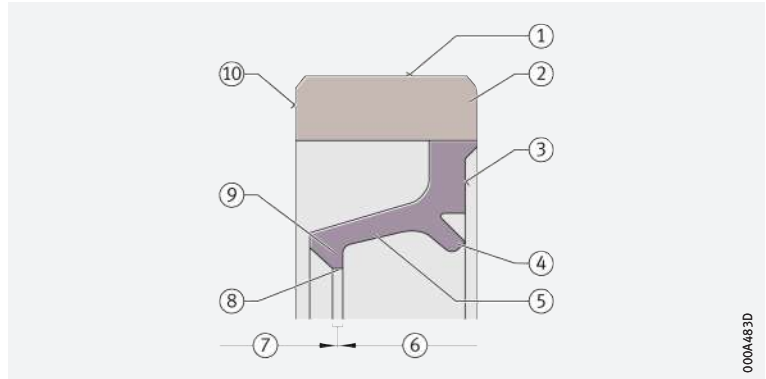

0.004483D

1
Characteristics and areas of application of sealing rings

Criteria	Sealing ring		
	Single lip		Double lip SD
	GR	G	
Resistance			
Mineral oils and greases	Normally resistant	Normally resistant	Normally resistant
Highly blended, synthetic lubricants	Conditionally resistant	Conditionally resistant	Conditionally resistant
Aggressive media	Consultation necessary	Consultation necessary	Not resistant
Weather			
Light, air	Moderate	Moderate	Good
Humidity	Good	Good	Good
Contamination resistance (lip facing outwards)	Good	Good	Very good
Application: shaft			
Sealing integrity	Good	Good	Good
Maximum circumferential velocity	10 m/s	10 m/s	10 m/s
Application: rod			
Maximum stroke velocity	3 m/s	3 m/s	3 m/s
Application: housing			
Sealing integrity	Satisfactory	Very good	Good
Tight fit	Very good	Good	Good
Press-in force	Medium	Slight	High
Soft housing material	Conditionally suitable	Highly suitable	Suitable
High thermal expansion	Conditionally suitable	Suitable	Suitable
Split housing	Conditionally suitable	Suitable	Conditionally suitable

☞ *Normally used with rotating shaft*

Operating behaviour

Sealing rings GR, G and SD are generally used in applications with a rotating shaft.

☞ *Sealing action is achieved by means of interference fit on the outside surface*

Static sealing of the housing bore

The outside surface of the sealing rings gives static sealing of the housing bore. The sealing action is achieved when the sealing ring is pressed into the housing bore with an interference fit.

The firm seating and sealing action are decisively influenced:

- by the design and accuracy of the housing bore
- by the outside surface of the sealing ring
- by correct fitting of the sealing rings.

☞ *Sealing rings G are suitable for fluid media*

The rubber encased sealing rings G adapt particularly well to the surface of the housing bore. The application and usage for sealing against fluid media must be validated in each specific case.

Static/dynamic sealing of the shaft

The diameter of the seal lip in the fitted seal is smaller than the shaft diameter. As a result, the seal lip in the unfitted seal has interference of the radial force F_R (contact force). The radial force is the sum of all the component forces from the seal edge of the sealing ring that act towards the centre point of the shaft.

☞ *Factors influencing the contact force*

It is dependent on:

- the deformation values of the seal lip – e.g. compression set, material hardness
- the geometry of the seal lip
- the operating temperature.

☞ *Static sealing*

With a stationary shaft, the seal integrity is primarily determined by the radial force.

☞ *Dynamic sealing*

With a rotating shaft, the seal integrity is additionally influenced by:

- the surface of the shaft
- the geometrical and positional tolerances – e.g. coaxiality, runout, perpendicularity
- tribology – lubrication, friction, wear
- the speed
- the temperature
- contamination.

☞ *The sealing action is aided by a grease collar*

Resistance and leakage

The sealing rings are resistant to undoped lubricants with a mineral oil base. For other media, resistance must be checked. In leakage, the medium escapes from the area to be sealed, especially at the seal edge. Slight leakage cannot be completely prevented with contact seals due to the sealing mechanism (grease or fluid film) even if the sealing ring is fully functional. Leakage can occur in the form of gas or vapour, droplets or drops. In droplet or drop leakage, a thin film of fluid is formed on the shaft. The sealing action is aided by a grease collar.

☞ *The sealing ring performs a dual function as a wiper*

Sealing on shaft with axial motion

With pure axial motion, the sealing ring acts as a wiper. As in the case of rotating shafts, it performs a dual function here. The sealing element:

- retains the lubricant in the area to be sealed
- prevents contaminants from penetrating the area to be sealed.

 *The sealing action is dependent on the interference*

The interference of the shaft/rod and seal lip diameter determines the sealing action. On the entry stroke of the rod, the sealing ring wipes away the lubricant and contaminant particles. The seal lip slides on the remaining lubricant film. On the counterstroke, lubricant is drawn out through the seal gap. This increases the lubricant film on the rod again.

 *Factors influencing the frictional torque*

Friction

The friction is influenced by:

- the material pair (elastomer/steel)
- the surface of the shaft
- the interference (radial force F_R)
- the lubrication of the contact surface (shaft/seal edge or rod/seal edge).



With a rotating shaft or motion of the rod, the adhesive friction present during standstill is converted to sliding friction. If lubricant is supplied, mixed friction occurs. The frictional power of the sealing rings increases with the diameter and the speed of the shaft. When the shaft starts to move, the frictional torque is higher than in normal operation, especially after a long period of standstill. If there is a lack of lubricant, the seal lip is not lubricated. The displacement forces increase as a result of dry running. Furthermore, the seal lip is damaged.

 *Causes of wear*

Wear

The following type of wear can occur at the seal edge:

- adhesive wear, e.g. if the seal lip sticks to the shaft after a long period of standstill
- if the seal edge slides on the contact surface
- under dry running
- if there are contaminant particles between the seal edge and the contact surface.

 *The sealing function is impaired by deposits*

After an extended running time, deposits may build up on the shaft/seal edge contact surface – e.g. comprising carbon and additive residues. These deposits can influence the sealing function and lead to leakage. Wear grooves may occur on the shaft, especially if a soft shaft material is used or there is a heavy stream of contaminant particles.

 *Wear behaviour is influenced by the shaft material*

The wear can be reduced by using a hardened shaft material or coated shafts. The abrasion resistance of NBR, FPM and HNBR elastomer is good, while that of TPU is very good.

 *Storage location*

Storage

Sealing rings should be stored in dry, dust-free rooms – at a maximum relative humidity of 65%, moderate ventilation and free from draughts. Observe the storage room requirements in accordance with DIN 7716.

Protect sealing rings from:

- direct sunlight
- UV light
- ozone (e.g. produced by electrical equipment)
- intense thermal radiation.



If these conditions are not maintained, this may cause unfavourable changes in the physical characteristics of the sealing rings (e.g. hardening).

Do not remove sealing rings from their original packaging until immediately before fitting.

 *Maximum storage time*

The maximum storage time from manufacture to fitting is:

- 5 years for NBR
- 10 years for FPM/HNBR.

 **Factors influencing the operating life**

Operating life

Physical, chemical and mechanical influences determine the operating life of sealing rings.

These include:

- ageing; the elastomer structure may undergo thermo-oxidative degradation, further crosslinking or embrittlement, depending on the environment and medium
- medium; media (fluids) may be dispersed within the structure or dissolve elastomer components. The elastomer may swell or contract as a result. If several media are affecting the seal at the same time, volume changes can be superimposed on each other and may be difficult to detect by optical means
- temperature; high temperatures and/or aggressive media can accelerate the decomposition and ageing processes
- wear and contamination.

 **Empirical values for operating life**

The interaction of these influences is very complex. As a result, it is not possible to calculate the operating life of sealing rings; only values based on practical experience can be given. Under normal operating conditions, seals can achieve a maximum operating life of:

- 10 000 operating hours in continuous operation or 3 years to 5 years.



The data given in ▶1028| 1 are guide values. They cannot be applied without restriction to all operating conditions. In case of doubt, please consult Schaeffler.

1.2 Lubrication

 **The seal edge must always be lubricated**

Sealing rings only function reliably if the seal edge is continually lubricated. Heat is generated at the seal edge. This is mainly dissipated to the shaft by the moving lubricant. Since elastomer gives only poor conduction of heat, heat cracks and wear can occur at the seal edge under inadequate lubrication. With grease lubrication, a grease collar protects the edge from excessive heating.

1.3 Temperature range

 **Excessively high temperatures can lead to loss of integrity at the seal edge**

The permissible operating temperature is dependent on the interaction between the medium, the temperature and its effect on the sealing ring material ▶1028| 1. With increasing circumferential velocity, the temperature at the contact surface increases as a result of the increasing shear forces in the lubricant and the low thermal conductivity of the elastomer. If the temperature of the seal edge increases too much, wear and heat cracks may occur that impair the seal integrity. The suitability of the sealing rings should be checked by tests as extremes of temperature are reached.

Possible operating temperatures of sealing rings ▶1031| 2.

 2
Permissible temperature ranges

Operating temperature	Sealing rings G and GR in standard design	Sealing rings SD
	-30 °C to +110 °C depending on the medium acting on the sealing ring	-30 °C to +100 °C depending on the medium acting on the sealing ring



In the event of anticipated temperatures which lie outside the stated values, please contact Schaeffler.

1.4 Suffixes

For a description of the suffixes used in this chapter ► 1032 | 3.

3
Suffixes and
corresponding descriptions

Suffix	Description of suffix	
FPM	Sealing rings G and GR for temperatures of -20 °C to +160 °C or circumferential velocities of up to 16 m/s	Special design, available by agreement only
HNBR	Sealing rings G and GR for temperatures of -30 °C to +140 °C or circumferential velocities of up to 12 m/s	

1.5 Structure of the product designation

5
Example of composition
of product designation

The designation of sealing rings follows a set model.
Example ► 1032 | 5.

5
Sealing ring G:
designation structure

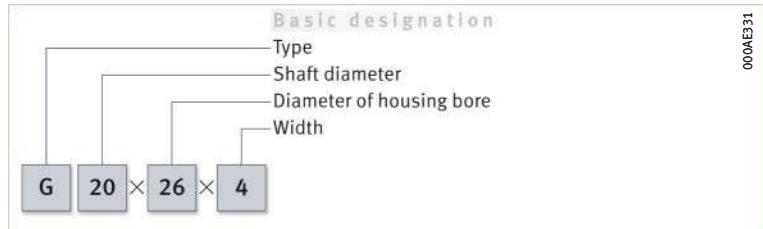

1.6 Design of bearing arrangements

5
The fit has a considerable
influence on the seating
of sealing rings

Design of housing bore

For a tight fit of the sealing rings in the housing bore, the values should be in accordance with ► 1033 | 5. If the housing and sealing ring materials have considerably different coefficients of thermal expansion, the tight fit of the sealing ring may change under hot or cold conditions.

6
Chamfers
on the housing bore

The housing bore should be chamfered in order to protect the sealing ring during fitting ► 1032 | 6 and ► 1032 | 4. The remaining seating length must be at least the nominal width of the sealing rings.



The design of the chamfer on the housing bore should be in accordance with the data in DIN 3760.

6
Chamfers on
end of shaft and
housing bore

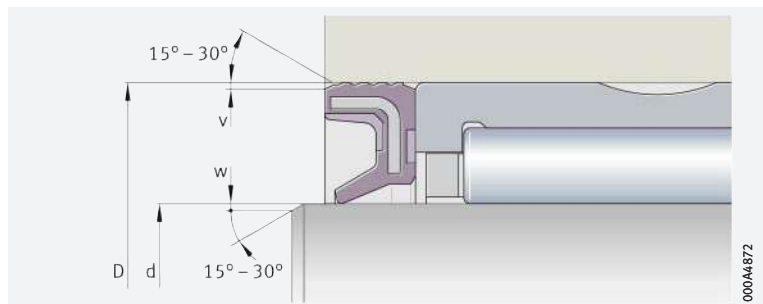

4
Chamfer dimensions

Chamfer	D ≤ 30 mm	D > 30 mm	d ≤ 30 mm	d > 30 mm
v _{min}	0,3	1% of D	-	-
w _{min}	-	-	0,3	0,5

The surface hardness of the seal running surfaces should be ≥ 55 HRC

Design of shaft

For a tight fit of the sealing rings on the shaft and seal running surfaces proven in practice, the values should be in accordance with **▶ 1033** | **▣ 5**. Where there are special requirements for sealing integrity, the values must be adjusted as necessary. Hard contaminant particles on the seal can lead to wear of the seal running surface. For this reason, only materials with a hardness of ≥ 55 HRC can be recommended for use as a seal running surface **▶ 1033** | **▣ 5**. The steels normally used in machine building are suitable. The sliding surface for the seal lips must not have any surface imperfections in accordance with ISO 8785. The design of seal running surfaces in accordance with the requirements in DIN 3760 is recommended.

Hardened and ground bearing rings used as raceway

For bearing positions with heavy contamination impact, the use of hardened rings ground free from spiral marks – such as inner rings LR – as a raceway for the seal lip is advisable, since these can be replaced if wear occurs **▶ 1033** | **📄 7**.



If increased wear is expected, the running surface can be coated. In this case, please consult Schaeffler.



Ring hardened and ground free from spiral marks – inner ring LR

- ① Single lip sealing ring G
- ② Needle roller bearing NK
- ③ Inner ring LR

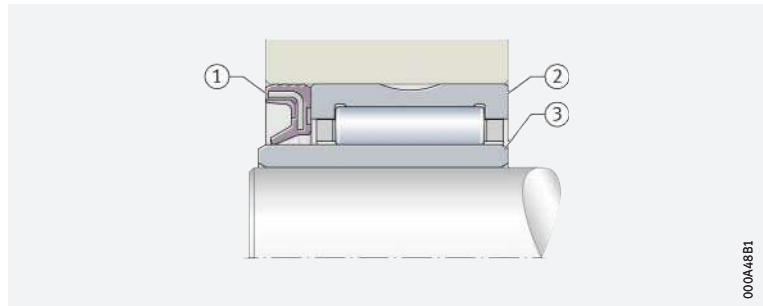

000448E1



In order to protect the seal lips during fitting, the ends of shafts should be chamfered in accordance with DIN 3760 **▶ 1032** | **📄 6** and **▶ 1032** | **▣ 4**.



Design of the shaft and housing bore

Sealing ring	Motion of shaft	Tolerance class of bore	Shaft		
			Tolerance class	Roughness	Hardness
G, GR, SD	Rotation only	G7 \oplus to R7 \oplus	g7 \oplus to k7 \oplus	$0,2 \leq R_{max} \leq 0,8$	55 HRC or 600 HV
SD	Axial motion			$R_{max} 0,3$	

1.7

Mounting and dismounting



Sealing rings must be handled and fitted correctly. This is the only way to ensure that they fulfil their sealing function correctly for a long period without problems.

Sealing lip orientation

Pay attention to the orientation of the seal lip:

- A seal lip facing outwards protects the bearing against the ingress of dust and contamination **▶ 1034** | **📄 8**.
- A seal lip facing inwards prevents the egress of lubricant from the bearing **▶ 1034** | **📄 8**.

Sealing rings SD

In the case of sealing rings SD, the side with the protective lip is the marked side. If it should be relubricated from inside, the protective lip must face outwards.



8
Seal lip orientation

- ① Seal lip facing outwards
- ② Sealing lip facing inwards

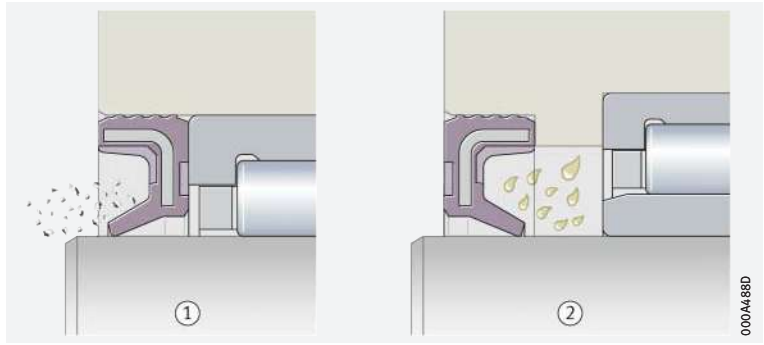

Mounting guidelines

The running surface on the shaft and seal lip must be oiled or greased. This reduces the frictional energy during initial movement. In the case of sealing rings with an elastomer encased reinforcing ring – sealing ring G – the outside surface should be oiled before pressing in. This makes it easier to fit the seal in the housing.

Fitting tools

Press sealing rings carefully into the housing bore using a pressing device and a suitable pressing tool ▶ 1034 | 9 and ▶ 1034 | 10.



Ensure that the seal lip is not damaged. Cover any sharp-edged shaft ends, slots, teeth or threads by means of fitting sleeves. Fit sealing rings in such a way that the pressing-in force is applied as close as possible to the outside diameter.

9
Fitting using a pressing tool

- ① Pressing tool (fitting mandrel)

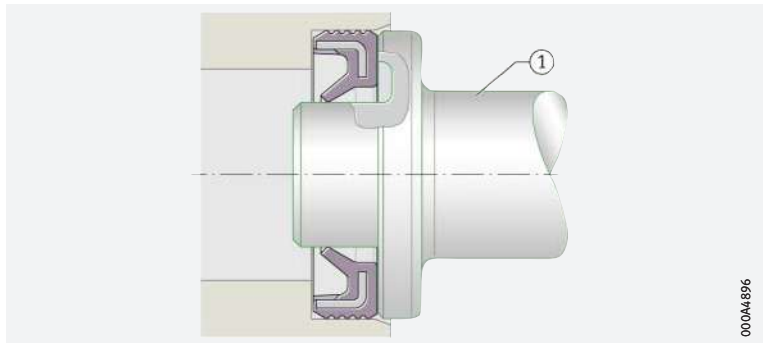

10
Fitting using a fitting sleeve

- ① Fitting sleeve

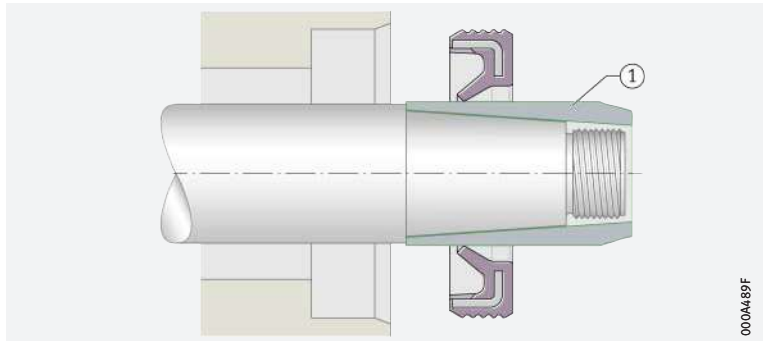



Pay attention to the perpendicular orientation of sealing rings

Fit sealing rings perpendicular to the shaft axis and the housing bore. Do not exceed the maximum deviation in perpendicularity between the sealing ring and the shaft axis once fitted ▶ 1034 | 6. Larger deviations will influence the sealing action.

6
Maximum perpendicularity deviation

Shaft diameter d mm	Maximum deviation mm
d < 25	0,1
d ≥ 25	0,2

-  **Sealing ring SD** In the case of sealing rings SD, the space between the seal lip and protective lip must be filled with grease.
-  **Checking of function** After fitting, allow the sealing rings to run in and check the sealing function. Slight leakage (forming a grease or liquid film) is desirable in order to lubricate the contact surface for the seal lips. The sealing action is aided by a grease collar.
-  **Relubrication** During relubrication, increase the pressure only slowly.

1.8 Legal notice regarding data freshness

 *The further development of products may also result in technical changes to catalogue products*

Of central interest to Schaeffler is the further development and optimisation of its products and the satisfaction of its customers. In order that you, as the customer, can keep yourself optimally informed about the progress that is being made here and with regard to the current technical status of the products, we publish any product changes which differ from the printed version in our electronic product catalogue.



We therefore reserve the right to make changes to the data and illustrations in this catalogue. This catalogue reflects the status at the time of printing. More recent publications released by us (as printed or digital media) will automatically precede this catalogue if they involve the same subject. Therefore, please always use our electronic product catalogue to check whether more up-to-date information or modification notices exist for your desired product.

Link to electronic product catalogue



The following link will take you to the Schaeffler electronic product catalogue: ► <https://medias.schaeffler.com>.



Sealing rings

Single lip or double lip

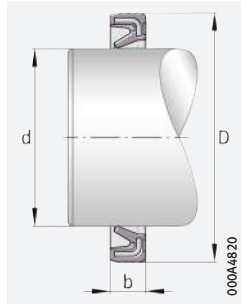

G
Single lip

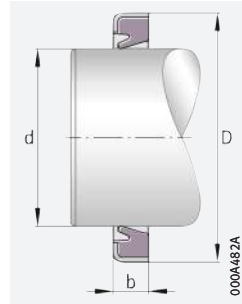

GR
Single lip

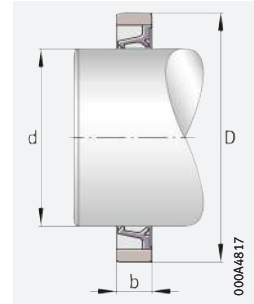

SD
Double lip

d = 4 – 80 mm

Sealing ring			Designation ▶ 1032 1.4 ▶ 1032 1.5			Mass m Sealing ring		
G	GR	SD	d×	D×	b ¹⁾	G ≈ g	GR ≈ g	SD ≈ g
	GR ²⁾		4	8	2		0,2	
	GR ²⁾		5	9	2		0,2	
	GR ²⁾		5	10	2		0,2	
	GR ²⁾		6	10	2		0,2	
	GR ²⁾		6	12	2		0,4	
	GR ²⁾		7	11	2		0,3	
	GR ²⁾		7	14	2		0,5	
G ²⁾	4)	4)	8	12	3	0,4		
G ²⁾	4)	SD ²⁾	8	15	3	0,7		0,3
G ²⁾	GR ²⁾	4)	9	13	3	0,5	0,5	
G ²⁾	4)	4)	9	16	3	0,7		
G ²⁾	GR ²⁾	4)	10	14	3	0,5	0,5	
G ²⁾	4)	SD ²⁾	10	17	3	0,9		0,4
G ²⁾	GR ²⁾	4)	12	16	3	0,6	0,6	
G ²⁾	4)	SD ²⁾	12	18	3	0,9		0,4
G ²⁾	GR ²⁾	SD ²⁾	12	19	3	1	1	0,5
G ²⁾	4)	4)	13	19	3	0,9		
G ²⁾	3)	SD ²⁾	14	20	3	1		0,5
G ²⁾	4)	4)	14	21	3	1,1		
G ²⁾	3)	SD ²⁾	14	22	3	1,3		0,7
G ²⁾	3)	SD ²⁾	15	21	3	1		0,5
G ²⁾	3)	SD ²⁾	15	23	3	1,3		0,7
G ²⁾	3)	SD ²⁾	16	22	3	1,3		0,6
G ²⁾	3)	SD ²⁾	16	24	3	1,3		0,7
G ²⁾	4)	4)	16	25	3	1,6		
G ²⁾	3)	SD ²⁾	17	23	3	1,3		0,6
G ²⁾	4)	SD ²⁾	17	25	3	1,5		0,8
G ²⁾	4)	SD ²⁾	18	24	3	1,2		0,6
G ²⁾	4)	SD ²⁾	18	26	4	1,8		1,1
G ²⁾	4)	SD ²⁾	19	27	4	2		1,1
G ²⁾	3)	SD ²⁾	20	26	4	1,8		0,8
G ²⁾	3)	SD ²⁾	20	28	4	2,1		1,1
G ²⁾	4)	4)	21	29	4	2,2		
G ²⁾	3)	SD ²⁾	22	28	4	1,8		0,9
G ²⁾	3)	SD ²⁾	22	30	4	2,2		1,3

Sealing ring			Designation ▶ 1032 1.4 ▶ 1032 1.5			Mass m Sealing ring		
G	GR	SD	d×	D×	b ¹⁾	G ≈ g	GR ≈ g	SD ≈ g
G ²⁾	3)	4)	24	32	4	2,5		
G ²⁾	3)	SD ²⁾	25	32	4	2,3		1,3
G ²⁾	4)	SD ²⁾	25	33	4	2,5		1,3
G ²⁾	3)	SD ²⁾	25	35	4	2,6		1,9
G ²⁾	4)	SD ²⁾	26	34	4	2,6		1,4
G ²⁾	3)	SD ²⁾	28	35	4	2,4		1,3
G ²⁾	3)	4)	28	37	4	3,1		
G ²⁾	4)	4)	29	38	4	3,2		
G ²⁾	3)	SD ²⁾	30	37	4	2,7		1,3
G ²⁾	3)	SD ²⁾	30	40	4	3,6		2,1
G ²⁾	4)	SD ²⁾	32	42	4	3,7		2,4
G ²⁾	4)	4)	32	45	4	5,1		
G ²⁾	3)	SD ²⁾	35	42	4	3		1,5
G ²⁾	4)	SD ²⁾	35	45	4	4,1		2,5
G ²⁾	4)	SD ²⁾	37	47	4	4		2,7
G ²⁾	4)	SD ²⁾	38	48	4	4,4		2,8
G ²⁾	4)	SD ²⁾	40	47	4	3,3		1,7
G ²⁾	3)	SD ²⁾	40	50	4	4,6		2,9
G ²⁾	3)	SD ²⁾	40	52	5	4,8		4,5
G ²⁾	3)	SD ²⁾	42	52	4	4,7		3
G ²⁾	4)	4)	43	53	4	4,8		
G ²⁾	3)	SD ²⁾	45	52	4	3,8		1,9
G ²⁾	3)	SD ²⁾	45	55	4	5,2		3,2
G ²⁾	3)	SD ²⁾	50	58	4	4,5		2,4
G ²⁾	3)	SD ²⁾	50	62	5	10,4		5,5
G ²⁾	3)		55	63	5	7,1		
G ²⁾	3)		70	78	5	9		
G ²⁾	4)		80	90	5	13,8		

medias ▶ <https://www.schaeffler.de/std/1D8C>

Special designs, available by agreement.

- 1) Width tolerance ± 0,2.
- 2) **Standard range.**
- 3) Please request information on delivery capability.
- 4) Available by agreement for economically viable batch sizes.



Axial deep groove ball bearings





Matrix for bearing preselection 1041

1 Axial deep groove ball bearings **1042**

- 1.1 Bearing design 1042
- 1.2 Load carrying capacity 1044
- 1.3 Compensation of angular misalignments 1044
- 1.4 Lubrication 1044
- 1.5 Sealing 1045
- 1.6 Speeds 1045



1.7	Noise	1045	1.17	Mounting and dismounting	1050
1.8	Temperature range	1046	1.18	Legal notice regarding data freshness	1050
1.9	Cages	1046	1.19	Further information	1051
1.10	Internal clearance	1047	Product tables	1052	
1.11	Dimensions, tolerances	1047	 Axial deep groove ball bearings, single direction	1052	
1.12	Suffixes	1048	 Axial deep groove ball bearings, double direction	1064	
1.13	Structure of bearing designation	1048			
1.14	Dimensioning	1048			
1.15	Minimum load	1049			
1.16	Design of bearing arrangements	1049			





Matrix for bearing preselection



The matrix gives an overview of the types and design features of axial deep groove ball bearings.

It can be used to make a preliminary assessment of whether a bearing is fundamentally suitable for the envisaged application.

The additional information provided in the product chapter (see column "detailed information") and in the Technical principles must, however, be observed in addition to this overview in selection of the bearing.

Design features and suitability			Axial deep groove ball bearings		
			single direction	double direction	detailed information
+++ extremely suitable ++ highly suitable + suitable (+) suitable with restrictions – not suitable/not applicable ✓ available					1042
Load carrying capacity	radial		–	–	▶ 1044 1.2
	axial, one direction		++	++	▶ 1044 1.2
	axial, both directions		–	++	▶ 1044 1.2
	moments		–	–	▶ 1044 1.2
Compensation of angular misalignments	static		(+) ¹⁾	(+) ¹⁾	▶ 1044 1.3
	dynamic		–	–	▶ 1044 1.3
Bearing design	cylindrical bore		✓	✓	▶ 1042 1.1
	tapered bore		–	–	▶ 1042 1.1
	separable		✓	✓	▶ 1050 1.17
Lubrication	greased		–	–	▶ 1044 1.4
Sealing	open		✓	✓	▶ 1045 1.5
	non-contact		–	–	–
	contact		–	–	–
Operating temperature in °C		from to	–30 +150 ¹⁾	–30 +150 ¹⁾	▶ 1046 1.8
Suitability for	high speeds		+	+	▶ 1045 1.6
	high running accuracy		+	+	▶ 1047 1.11 ▶ 114
	low-noise running		(+)	(+)	▶ 1045 1.7 ▶ 27
	high rigidity		++	++	▶ 54
	reduced friction		+	+	▶ 56
	length compensation within bearing		–	–	–
	non-locating bearing arrangement		–	–	▶ 139
	locating bearing arrangement		+++	+++	▶ 139
X-life bearings			–	–	–
Bearing bore d in mm		from to	10 260 ²⁾	10 190	▶ 1052 ▶ 1064
Product tables		from page	1052	1064	

¹⁾ Valid for bearings with spherical housing locating washer

²⁾ Larger catalogue bearings
 ▶ GL 1

1 Axial deep groove ball bearings



Axial deep groove ball bearings:

- are standardised, ready-to-fit units with high axial load carrying capacity ▶ 1043 | 2 and ▶ 1043 | 3
- are suitable exclusively for the support of predominantly axial loads ▶ 1044 | 1.2
- are particularly suitable where the bearing position is subjected to high axial loads from one or both sides, but the requirements for axial load carrying capacity of the bearings are not so high that axial cylindrical roller bearings with even higher load carrying capacity must be used
- permit higher speeds than roller or needle roller and cage assemblies ▶ 1042 | 1
- compensate, in conjunction with a spherical housing locating washer, static misalignments between the shaft and housing ▶ 1044 | 1.3.

For an overview of other product-specific features, see the Matrix for bearing preselection ▶ 1041.

1
Axial deep groove ball bearing: comparison of speed and load carrying capacity with axial cylindrical roller bearing and axial needle roller and cage assembly

n_G = limiting speed
 F_a = axial load
 C_a = basic axial dynamic load rating

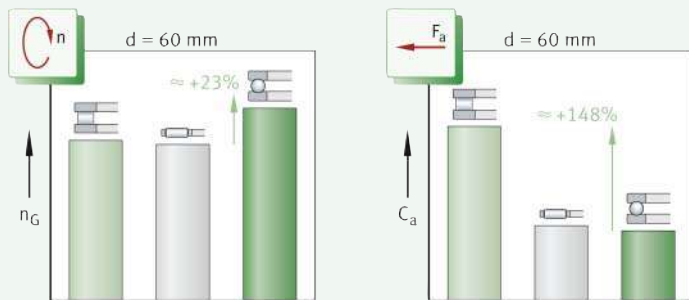

1.1 Bearing design

Design variants

Axial deep groove ball bearings are available as:

- single direction bearings ▶ 1043 | 2
- double direction bearings ▶ 1043 | 3.

Non-self-retaining, easy-to-fit bearing units

Basic bearing design

Axial deep groove ball bearings are part of the group of axial ball bearings. The bearings are of a multi-piece construction and, due to their design, are not self-retaining. As a result, it is possible to mount the bearing parts (shaft locating washer, housing locating washer, ball and cage assembly, support washer) separately from each other. In order to guide the balls, the shaft and housing locating washer have raceway grooves (formed rolling element raceways) with a defined osculation, in which the rolling elements circulate. The ball set is retained by a sheet steel cage or a solid brass cage ▶ 1046 | 2. When using these bearings, the designer does not need to produce the bearing parts for his bearing arrangement and match these to each other himself, but can instead use a standardised, ready-to-fit unit.



Single direction axial deep groove ball bearings

Ready-to-fit bearing unit for compact axial designs

These axial deep groove ball bearings comprise a shaft locating washer, a housing locating washer and a ball and cage assembly ▶1043|2. In order to ensure centring of the washers with a precise fit, the bore of the shaft locating washer (d) is ground. In contrast, the bore of the housing locating washer (D_1) is more generously dimensioned and is turned. The housing locating washer can be flat or spherical and can be configured with or without a support washer. The support washers U2 and U3 must be ordered in addition to the bearing. Load carrying capacity of single direction bearings ▶1044|1.2.



Axial deep groove ball bearings, single direction

F_a = axial load

- ① Axial deep groove ball bearing with flat housing locating washer
- ② Axial deep groove ball bearing with spherical housing locating washer and support washer
- ③ Shaft locating washer
- ④ Housing locating washer
- ⑤ Support washer (flat or spherical)

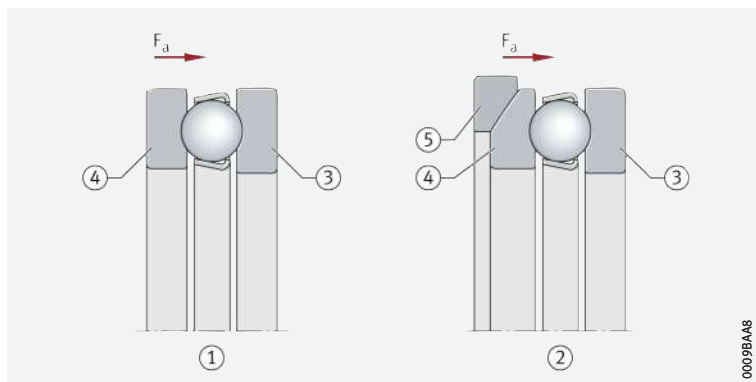

0009BA48

Double direction axial deep groove ball bearings

Ready-to-fit bearing unit, suitable for combination with support washers

Double direction bearings comprise a shaft locating washer, two housing locating washers and two ball and cage assemblies ▶1043|3. They can also be combined with support washers U2 and U3. The housing locating washers and ball sets correspond to the designs of the single direction bearings. Load carrying capacity of double direction bearings ▶1044|1.2.



Axial deep groove ball bearings, double direction

F_a = axial load

- ① Axial deep groove ball bearing with flat housing locating washers
- ② Axial deep groove ball bearing with spherical housing locating washers, without support washer
- ③ Shaft locating washer
- ④ Housing locating washer (flat or spherical)

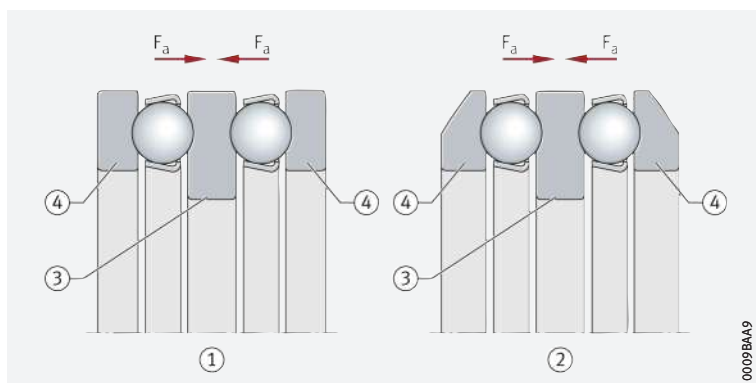

0009BA49

1.2 Load carrying capacity



Axial deep groove ball bearings are suitable for the support of predominantly axial loads. They must not be subjected to predominantly radial loads.

☞ *Single direction bearings*

Single direction axial deep groove ball bearings can support axial forces in one direction and support the shaft on one side ► 1043 | ② 2.

☞ *Double direction bearings*

Double direction axial deep groove ball bearings support axial forces in both directions and can guide the shaft on both sides ► 1043 | ② 3.

1.3 Compensation of angular misalignments



Axial deep groove ball bearings react with high sensitivity to angular misalignments. In cases where the contact face for the housing locating washer is not vertical (perpendicular) to the bearing axis, the angular misalignment can be compensated by means of bearings with a spherical housing locating washer and support washer ► 1043 | ② 2.

Single direction bearings

☞ *Series 511, 512, 513, 514 do not permit angular adjustment*

Bearings of series 511, 512, 513 and 514 have a flat housing locating washer. As a result, they do not permit angular misalignment or skewing between the shaft and housing.

☞ *Series 532, 533 permit angular adjustment*

Bearings of series 532 and 533 have a spherical housing locating washer. With an appropriate housing design and in conjunction with support washers U2 and U3, they are variable in angle as a result and can therefore tolerate static misalignments of the shaft relative to the housing within certain limits.

Double direction bearings

☞ *Series 522, 523 do not permit angular adjustment*

Bearings of series 522 and 523 have two flat housing locating washers and do not permit angular adjustment.

☞ *Series 542, 543 permit angular adjustment*

Bearings of series 542 and 543 have spherical housing locating washers. With an appropriate housing design and in conjunction with support washers U2 and U3, they are variable in angle as a result and can therefore tolerate static misalignments of the shaft relative to the housing within certain limits.

1.4 Lubrication

☞ *Oil or grease lubrication is possible*

The bearings are not greased. In order to prevent direct metallic contact between rolling elements, raceways and cages, they must be lubricated. Oil or grease lubrication is suitable. The lubricant reduces the wear and also protects the surfaces against corrosion. The choice of lubricant is essentially dependent on the operating temperatures and the speeds; it is also influenced, however, by the load, mounting position, oscillations etc.



If there is any uncertainty regarding the suitability of the selected lubricant for the application, please consult Schaeffler or the lubricant manufacturer.



1.5 Sealing

The bearings are of an open design

Axial deep groove ball bearings are supplied without seals. As a result, sealing of the bearing position must be carried out in the adjacent construction. This must reliably prevent:

- moisture and contaminants from entering the bearing
- the egress of lubricant from the bearing.

1.6 Speeds

Limiting speeds and reference speeds in the product tables

Two speeds are generally indicated in the product tables ▶ 1052 | :

- the kinematic limiting speed n_G
- the thermal speed rating $n_{\vartheta r}$.

Limiting speed



The limiting speed n_G is the kinematically permissible speed of a bearing. Even under favourable mounting and operating conditions, this value should not be exceeded without prior consultation with Schaeffler ▶ 64. The values in the product tables are valid for oil lubrication.

Values for grease lubrication

For grease lubrication, 75% of the value stated in the product tables is permissible in each case.

Reference speeds

$n_{\vartheta r}$ is used to calculate n_{ϑ}

The thermal speed rating $n_{\vartheta r}$ is not an application-oriented speed limit, but is a calculated ancillary value for determining the thermally safe operating speed n_{ϑ} ▶ 64.

1.7 Noise

Schaeffler Noise Index

The Schaeffler Noise Index (SGI) is not yet available for this bearing type ▶ 69. The data for these bearing series will be introduced and updated in stages.

Further information:

- **medias** ▶ <https://medias.schaeffler.com>.

1.8 Temperature range

Limiting values

The operating temperature of the bearings is limited by:

- the dimensional stability of the bearing washers and rolling elements
- the support washers
- the cage
- the lubricant.

-30 °C to +150 °C

Possible operating temperatures for axial deep groove ball bearings **► 1046** | 1. The support washers are made from rolling bearing steel and are suitable for the same temperatures as the bearing washers and rolling elements. The temperature limit values of the lubricant must be observed.

1
Permissible temperature ranges

Operating temperature	Axial deep groove ball bearings with sheet steel or brass cages
	-30 °C to +150 °C



In the event of anticipated temperatures which lie outside the stated values, please contact Schaeffler.

1.9 Cages

Sheet steel cages or solid brass cages are used as standard

Standard cages for axial deep groove ball bearings **► 1046** | 2. Other cage designs are available by agreement. With such cages, however, suitability for high speeds and temperatures as well as the basic load ratings may differ from the values for the bearings with standard cages. Bearings with sheet steel cages do not have a cage suffix **► 1046** | 2.



If there is any uncertainty regarding cage suitability for a specific application, please consult Schaeffler.

2
Cage, cage suffix, bore code

Bearing series	Sheet steel cage	Solid brass cage
	–	MP
	Bore code	
511	up to 28	from 30
512	up to 28	from 30
513	up to 20	from 22
514	up to 11	from 12
522	up to 28	from 30
523	up to 20	from 22
524	06 to 11	–
532	up to 28	from 30
533	up to 20	from 22
534	06 to 11	–
542	up to 28	from 30
543	up to 20	22, 24
544	06 to 11	–



1.10 Internal clearance

⊗ Axial clearance and preload is determined by the application

In the case of axial deep groove ball bearings, the internal clearance (axial clearance) is only achieved when the bearings are mounted. The requisite axial clearance of the bearing arrangement is dependent on the application and must take account of the conditions in the bearing arrangement while warm from operation and subjected to load. If axial deep groove ball bearings are subjected to vibrations while under predominantly static load for example, they must be lightly preloaded. Preload can be applied, for example, using housing nuts ▶ 1047 | 4. Other suitable means include shaft nuts, disc springs, calibrated sheets (shims) etc. It must always be ensured that no slippage occurs in operation between the rolling elements and raceways ▶ 1049 | 1.15. It must also be ensured that the preload does not exceed the optimum value, otherwise there will be an increase in friction and therefore in heat generation in the bearing. These will both have a negative effect on the operating life of the bearings.



If there is any uncertainty regarding the setting of the axial clearance, Schaeffler must always be consulted.



Setting the axial clearance of a double direction axial deep groove ball bearing by means of a housing nut

① Housing nut

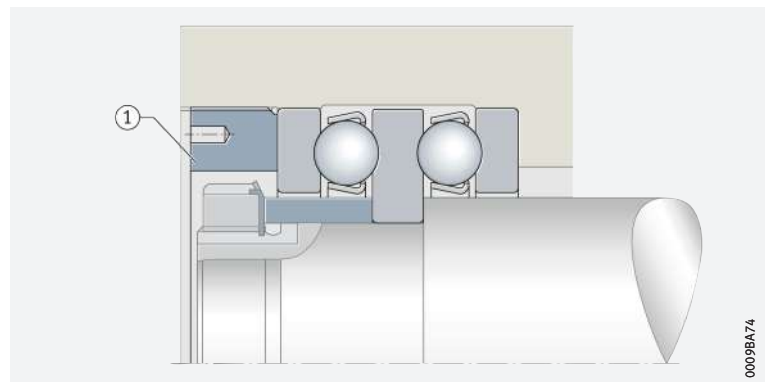

1.11 Dimensions, tolerances

Dimension standards



Bearings with a flat locating surface on the housing locating washer correspond to ISO 104:2015 or DIN 616:2000 and DIN 711:2010 as well as DIN 715:2011.

Bearings with a spherical locating surface on the housing locating washer correspond to ISO 20516:2007 and DIN 711:2010 as well as DIN 715:2011.

Chamfer dimensions



The limiting dimensions for chamfer dimensions correspond to DIN 620-6:2004. Overview and limiting values ▶ 138. Nominal value of chamfer dimension ▶ 1052 | 28.

Tolerances



The tolerances for the dimensional and running accuracy of axial deep groove ball bearings correspond to tolerance class Normal in accordance with ISO 199:2014. Tolerance values in accordance with ISO 199 ▶ 133 | 25 to ▶ 135 | 28.

1.12 Suffixes

For a description of the suffixes used in this chapter ▶ 1048 | 3 and **medias** interchange ▶ <https://www.schaeffler.de/std/1D52>.

3
Suffixes and corresponding descriptions

Suffix	Description of suffix	
MP	Solid brass cage, ball-guided	Standard
P5	Bearing in tolerance class 5	Special design, available by agreement
P6	Bearing in tolerance class 6	

1.13 Structure of bearing designation

Examples of composition of bearing designation

The designation of bearings follows a set model. Examples ▶ 1048 | 5 and ▶ 1048 | 6. The composition of designations is subject to DIN 623-1 ▶ 102 | 10.

5
Axial deep groove ball bearing, single direction, with spherical housing locating washer and support washer: designation structure



6
Axial deep groove ball bearing, double direction, with spherical housing locating washers: designation structure



1.14 Dimensioning

Equivalent dynamic bearing load

$P = F_a$ Axial deep groove ball bearings can only support axial forces ▶ 1044 | 1.2. As a result, $P = F_a$ ▶ 1048 | 1.

f1
Equivalent dynamic load

$$P = F_a$$

Legend

P	N	Equivalent dynamic bearing load
F_a	N	Axial load.

Equivalent static bearing load

$P_0 = F_{0a}$ Since the bearings can only support axial loads, $P_0 = F_{0a}$ ▶ 1048 | 2.

f2
Equivalent static load

$$P_0 = F_{0a}$$

Legend

P_0	N	Equivalent static bearing load
F_{0a}	N	Largest axial load present (maximum load).



$$S_0 = C_0/P_0$$

Static load safety factor

In addition to the basic rating life $L(L_{10h})$, it is also always necessary to check the static load safety factor $S_0 \geq 2.27$ | f1 5.

f1 3
Static load safety factor

$$S_0 = \frac{C_0}{P_0}$$

Legend

S_0	–	Static load safety factor
C_0	N	Basic static load rating
P_0	N	Equivalent static bearing load.

1.15 Minimum load

In order to prevent damage due to slippage, a minimum axial load of $F_{a\ min}$ is required

Under axial load, the balls are guided under favourable rolling conditions at the base of the groove. This deteriorates, however, if the centrifugal force occurring at higher speeds and very low loads presses the balls outwards. In this case, detrimental sliding motions can occur between the rolling elements and the raceways due to centrifugal forces and gyroscopic moments. In order to prevent these sliding motions, the bearings must be subjected to the minimum axial load $F_{a\ min} \geq 1049$ | f1 4.

This can also be achieved by means of preloading, for example using springs. The minimum load factor A is given in the product tables. For n_{max} , the maximum operating speed must be used.

f1 4
Minimum axial load

$$F_{a\ min} = 1000 \cdot A \cdot \left(\frac{n_{max}}{1000}\right)^2$$

Legend

$F_{a\ min}$	N	Minimum axial load
A	–	Minimum load factor ≥ 1052 f1 4
n_{max}	min^{-1}	Maximum operating speed.

1.16 Design of bearing arrangements

In the case of misalignments: use spherical support washers or produce the locating surface in the housing to a spherical design

Bearings with spherical housing locating washers can compensate, in conjunction with a spherical bearing seating surface, misalignments between the locating surface in the housing and on the shaft ≥ 1044 | 1.3. These bearings can be mounted together with support washers also of a spherical design or directly in the housing. In this case, however, the locating surface in the housing must also be of a spherical design.

Shaft tolerances

Single direction bearings should have the shaft tolerance j6 \oplus , while k6 \ominus should be selected for double direction bearings.

Tolerances for the housing bore

The tolerance of the locating bore is dependent on the running accuracy to be achieved. For normal running accuracy, it should be in the tolerance class E8 \oplus , for high running accuracy, it should be in the tolerance class H6 \oplus .

The contact surfaces for the washers must be of sufficient height

Mounting dimensions for the contact surfaces of bearing rings

The shoulders on the adjacent construction (shaft and housing) must be sufficiently high that the shaft and housing locating washers are supported over at least half their height. The abutment shoulders should be rigid, flat and perpendicular to the axis of rotation. Proven mounting dimensions for the radii and diameters of abutment shoulders are given in the product tables ≥ 1052 | f1 4. These dimensions are limiting dimensions (maximum or minimum dimensions); the actual values should not be higher or lower than specified.

1.17 Mounting and dismounting

Do not transpose the shaft and housing locating washer

In the case of single direction bearings, it must be ensured that the shaft and housing locating washer are not exchanged with each other but are mounted in the correct position.



On the shaft locating washer, the bore d is ground and the outside diameter d_1 is not ground ▶ 1050 | 7. For reliable operation, the shaft locating washer should always abut a shoulder of corresponding dimensions or a support ring securely located on the shaft.

As the bearings are not self-retaining, they are easy to mount

Axial deep groove ball bearings are not self-retaining. As a result, the bearing washers and the ball and cage assembly can be mounted separately from each other ▶ 1042 | 1.1. This gives simplified mounting of the bearings.



Axial deep groove ball bearing, single direction

- 1 Shaft locating washer, bore d ground, outside diameter d_1 not ground

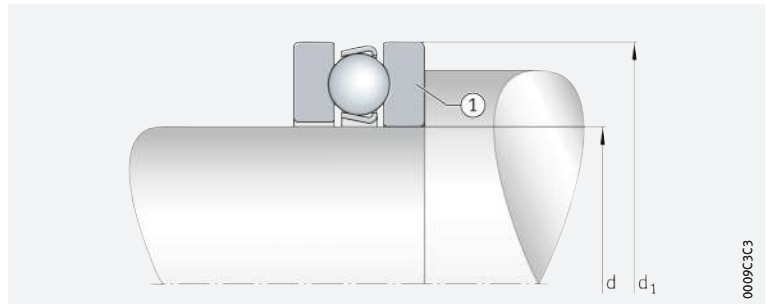

Rolling bearings must be handled with great care

Schaeffler Mounting Handbook

Rolling bearings are well-proven precision machine elements for the design of economical and reliable bearing arrangements, which offer high operational security. In order that these products can function correctly and achieve the envisaged operating life without detrimental effect, they must be handled with care.



The Schaeffler Mounting Handbook MH 1 gives comprehensive information about the correct storage, mounting, dismounting and maintenance of rotary rolling bearings ▶ <https://www.schaeffler.de/std/1D53>. It also provides information which should be observed by the designer, in relation to the mounting, dismounting and maintenance of bearings, in the original design of the bearing position. This book is available from Schaeffler on request.

1.18 Legal notice regarding data freshness

The further development of products may also result in technical changes to catalogue products

Of central interest to Schaeffler is the further development and optimisation of its products and the satisfaction of its customers. In order that you, as the customer, can keep yourself optimally informed about the progress that is being made here and with regard to the current technical status of the products, we publish any product changes which differ from the printed version in our electronic product catalogue.



We therefore reserve the right to make changes to the data and illustrations in this catalogue. This catalogue reflects the status at the time of printing. More recent publications released by us (as printed or digital media) will automatically precede this catalogue if they involve the same subject. Therefore, please always use our electronic product catalogue to check whether more up-to-date information or modification notices exist for your desired product.

Link to electronic product catalogue



The following link will take you to the Schaeffler electronic product catalogue: ▶ <https://medias.schaeffler.com>.

1.19 Further information

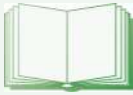

In addition to the data in this chapter, the following chapters in Technical principles must also be observed in the design of bearing arrangements:

- Determining the bearing size ▶ 34
- Rigidity ▶ 54
- Friction and increases in temperature ▶ 56
- Speeds ▶ 64
- Bearing data ▶ 97
- Lubrication ▶ 70
- Sealing ▶ 182
- Design of bearing arrangements ▶ 139
- Mounting and dismounting ▶ 191.



Axial deep groove ball bearings

Single direction

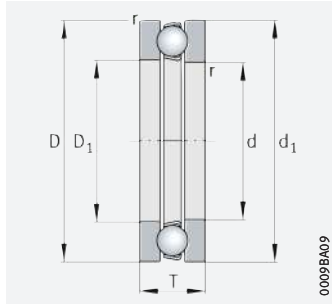

511, 512, 513, 514

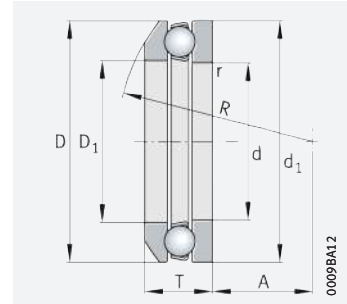

532, 533
Spherical housing locating washer

d = 10 – 30 mm

Main dimensions			Basic load ratings		Fatigue limit load C_{ua} N	Minimum load factor A	Limiting speed n_G min ⁻¹	Speed rating $n_{\theta r}$ min ⁻¹	Mass m		Designation	
d	D	T	dyn. C_a N	stat. C_{0a} N					Bearing ≈ kg	Support washer ≈ kg	Bearing	Support washer
10	24	9	10 000	14 000	620	0,001	12 700	19 200	0,018	–	51100	–
	26	11	12 700	17 100	760	0,002	10 900	19 100	0,03	–	51200	–
	26	11,6	12 700	17 100	760	0,002	10 900	19 100	0,028	0,008	53200	U200
12	26	9	10 300	15 400	690	0,001	13 100	16 900	0,021	–	51101	–
	28	11	13 200	19 000	840	0,002	11 300	16 900	0,03	–	51201	–
	28	11,4	13 200	19 000	840	0,002	11 300	16 900	0,03	0,009	53201	U201
15	28	9	10 500	16 800	750	0,002	13 100	14 000	0,027	–	51102	–
	32	12	16 600	24 800	1 100	0,003	9 800	14 300	0,049	–	51202	–
	32	13,3	16 600	24 800	1 100	0,003	9 800	14 300	0,048	0,013	53202	U202
17	30	9	11 300	19 600	870	0,002	12 900	12 500	0,028	–	51103	–
	35	12	17 200	27 500	1 210	0,004	9 700	13 200	0,052	–	51203	–
	35	13,2	17 200	27 500	1 210	0,004	9 700	13 200	0,055	0,015	53203	U203
20	35	10	15 000	26 500	1 180	0,004	10 900	11 100	0,04	–	51104	–
	40	14	21 100	37 500	1 660	0,007	8 500	11 600	0,082	–	51204	–
	40	14,7	21 100	37 500	1 660	0,007	8 500	11 600	0,081	0,02	53204	U204
25	42	11	18 100	35 500	1 570	0,006	9 700	9 500	0,055	–	51105	–
	47	15	26 500	50 000	2 220	0,013	7 500	9 800	0,114	–	51205	–
	47	16,7	26 500	50 000	2 220	0,013	7 500	9 800	0,121	0,031	53205	U205
	52	18	34 500	55 000	2 450	0,019	6 000	10 400	0,154	–	51305	–
	52	19,8	34 500	55 000	2 450	0,019	6 000	10 400	0,203	0,043	53305	U305
	60	24	43 000	66 000	2 950	0,032	4 700	10 900	0,295	–	51405	–
30	47	11	18 800	40 000	1 770	0,008	9 300	8 100	0,063	–	51106	–
	52	16	23 900	46 000	2 040	0,014	7 300	8 600	0,136	–	51206	–
	52	17,8	23 900	46 000	2 040	0,014	7 300	8 600	0,147	0,032	53206	U206
	60	21	35 500	65 000	2 850	0,028	5 700	9 300	0,244	–	51306	–
	60	22,6	35 500	65 000	2 850	0,028	5 700	9 300	0,303	0,055	53306	U306
	70	28	70 000	112 000	5 000	0,077	3 850	9 100	0,49	–	51406	–

medias ► <https://www.schaeffler.de/std/1E13>

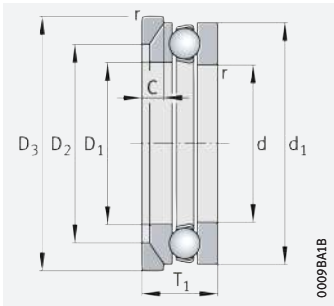

532, 533
Spherical housing locating washer
Support washer U2, U3

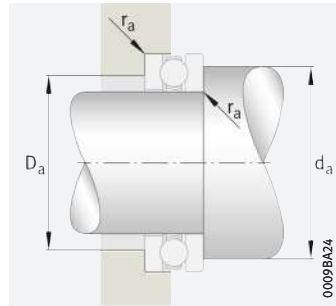

Mounting dimensions

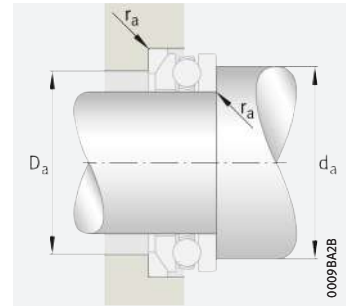

Mounting dimensions

Dimensions										Mounting dimensions		
d	D ₁	d ₁	r	R	A	D ₂	D ₃	C	T ₁	d _a	D _a	r _a
			min.							min.	max.	max.
10	11	24	0,3	–	–	–	–	–	–	18	16	0,3
	12	26	0,6	–	–	–	–	–	–	20	16	0,6
	12	26	0,6	22	8,5	18	28	3,5	13	20	18	0,6
12	13	26	0,3	–	–	–	–	–	–	20	18	0,3
	14	28	0,6	–	–	–	–	–	–	22	18	0,6
	14	28	0,6	25	11,5	20	30	3,5	13	22	20	0,6
15	16	28	0,3	–	–	–	–	–	–	23	20	0,3
	17	32	0,6	–	–	–	–	–	–	25	22	0,6
	17	32	0,6	28	12	24	35	4	15	25	24	0,6
17	18	30	0,3	–	–	–	–	–	–	25	22	0,3
	19	35	0,6	–	–	–	–	–	–	28	24	0,6
	19	35	0,6	32	16	26	38	4	15	28	26	0,6
20	21	35	0,3	–	–	–	–	–	–	29	26	0,3
	22	40	0,6	–	–	–	–	–	–	32	28	0,6
	22	40	0,6	36	18	30	42	5	17	32	30	0,6
25	26	42	0,6	–	–	–	–	–	–	35	32	0,6
	27	47	0,6	–	–	–	–	–	–	38	34	0,6
	27	47	0,6	40	19	36	50	5,5	19	38	36	0,6
	27	52	1	–	–	–	–	–	–	41	36	1
	27	52	1	45	21	38	55	6	22	41	38	1
	27	60	1	–	–	–	–	–	–	46	39	1
30	32	47	0,6	–	–	–	–	–	–	40	37	0,6
	32	52	0,6	–	–	–	–	–	–	43	39	0,6
	32	52	0,6	45	22	42	55	5,5	20	43	42	0,6
	32	60	1	–	–	–	–	–	–	48	42	1
	32	60	1	50	22	45	62	7	25	48	45	1
	32	70	1	–	–	–	–	–	–	54	46	1



Axial deep groove ball bearings

Single direction

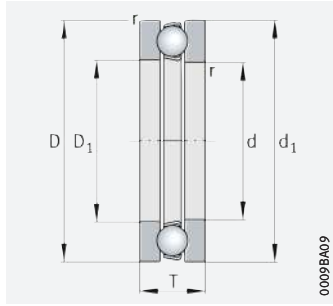

511, 512, 513, 514

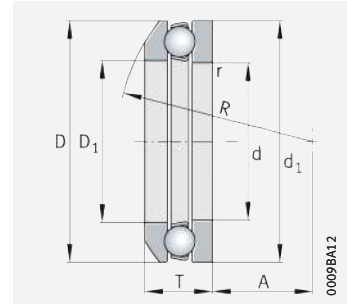

532, 533
Spherical housing locating washer

d = 35 – 55 mm

Main dimensions			Basic load ratings		Fatigue limit load C_{ua} N	Minimum load factor A	Limiting speed n_G min^{-1}	Speed rating $n_{\theta r}$ min^{-1}	Mass m		Designation	
d	D	T	dyn. C_a N	stat. C_{0a} N					Bearing $\approx \text{kg}$	Support washer $\approx \text{kg}$	Bearing	Support washer
35	52	12	20 000	46 500	2 060	0,011	8 800	6 800	0,089	–	51107	–
	62	18	35 500	67 000	3 000	0,028	6 000	8 000	0,198	–	51207	–
	62	19,9	35 500	67 000	3 000	0,028	6 000	8 000	0,265	0,057	53207	U207
	68	24	50 000	89 000	3 900	0,05	4 850	8 200	0,351	–	51307	–
	68	25,6	50 000	89 000	3 900	0,05	4 850	8 200	0,437	0,082	53307	U307
	80	32	76 000	126 000	5 600	0,11	3 600	8 500	0,709	–	51407	–
40	60	13	25 500	62 000	2 750	0,02	7 400	6 400	0,114	–	51108	–
	68	19	44 000	97 000	4 300	0,05	5 500	6 900	0,257	–	51208	–
	68	20,3	44 000	97 000	4 300	0,05	5 500	6 900	0,259	0,07	53208	U208
	78	26	61 000	112 000	5 000	0,081	4 250	7 600	0,536	–	51308	–
	78	28,5	61 000	112 000	5 000	0,081	4 250	7 600	0,561	0,114	53308	U308
	90	36	96 000	170 000	7 500	0,18	3 250	7 600	1,03	–	51408	–
45	65	14	26 500	69 000	3 050	0,025	7 100	5 800	0,087	–	51109	–
	73	20	39 000	80 000	3 550	0,043	5 500	6 600	0,279	–	51209	–
	73	21,3	39 000	80 000	3 550	0,043	5 500	6 600	0,278	0,087	53209	U209
	85	28	75 000	140 000	6 300	0,12	3 800	6 800	0,612	–	51309	–
	85	30,1	75 000	140 000	6 300	0,12	3 800	6 800	0,783	0,171	53309	U309
	100	39	123 000	222 000	9 800	0,29	2 850	6 900	1,36	–	51409	–
50	70	14	27 000	75 000	3 300	0,029	6 800	5 200	0,151	–	51110	–
	78	22	50 000	106 000	4 700	0,069	4 950	5 700	0,346	–	51210	–
	78	23,5	50 000	106 000	4 700	0,069	4 950	5 700	0,341	0,098	53210	U210
	95	31	82 000	169 000	7 500	0,18	3 550	6 400	0,932	–	51310	–
	95	34,3	82 000	169 000	7 500	0,18	3 550	6 400	0,97	0,22	53310	U310
	110	43	138 000	255 000	11 400	0,4	2 650	6 500	1,81	–	51410	–
55	78	16	30 500	75 000	3 300	0,036	6 100	5 200	0,208	–	51111	–
	90	25	58 000	133 000	5 900	0,11	4 350	5 700	0,382	–	51211	–
	90	27,3	58 000	133 000	5 900	0,11	4 350	5 700	0,609	0,152	53211	U211
	105	35	102 000	207 000	9 200	0,26	3 200	6 000	1,3	–	51311	–
	105	39,3	102 000	207 000	9 200	0,26	3 200	6 000	1,38	0,27	53311	U311
	120	48	167 000	315 000	14 000	0,59	2 340	6 000	2,83	–	51411	–

medias ► <https://www.schaeffler.de/std/1E14>

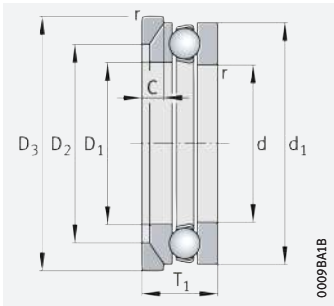

532, 533
Spherical housing locating washer
Support washer U2, U3

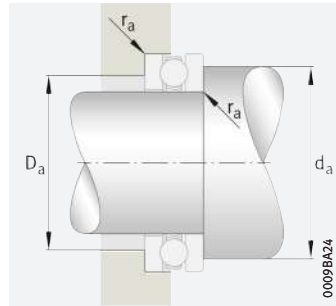

Mounting dimensions

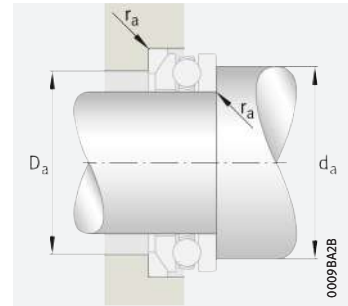

Mounting dimensions

Dimensions

Mounting dimensions

d	D ₁	d ₁	r	R	A	D ₂	D ₃	C	T ₁	Mounting dimensions		
										d _a min.	D _a max.	r _a max.
35	37	52	0,6	-	-	-	-	-	-	45	42	0,6
	37	62	1	-	-	-	-	-	-	51	46	1
	37	62	1	50	24	48	65	7	22	51	48	1
	37	68	1	-	-	-	-	-	-	55	48	1
	37	68	1	56	24	52	72	7,5	28	55	52	1
	37	80	1,1	-	-	-	-	-	-	62	53	1
40	42	60	0,6	-	-	-	-	-	-	52	48	0,6
	42	68	1	-	-	-	-	-	-	57	51	1
	42	68	1	56	28,5	55	72	7	23	57	55	1
	42	78	1	-	-	-	-	-	-	63	55	1
	42	78	1	64	28	60	82	8,5	31	63	60	1
	42	90	1,1	-	-	-	-	-	-	70	60	1
45	47	65	0,6	-	-	-	-	-	-	57	53	0,6
	47	73	1	-	-	-	-	-	-	62	56	1
	47	73	1	56	26	60	78	7,5	24	62	60	1
	47	85	1	-	-	-	-	-	-	69	61	1
	47	85	1	64	25	65	90	10	33	69	65	1
	47	100	1,1	-	-	-	-	-	-	78	67	1
50	52	70	0,6	-	-	-	-	-	-	62	58	0,6
	52	78	1	-	-	-	-	-	-	67	61	1
	52	78	1	64	32,5	62	82	7,5	26	67	62	1
	52	95	1,1	-	-	-	-	-	-	77	68	1
	52	95	1,1	72	28	72	100	11	37	77	72	1
	52	110	1,5	-	-	-	-	-	-	86	74	1,5
55	57	78	0,6	-	-	-	-	-	-	69	64	0,6
	57	90	1	-	-	-	-	-	-	76	69	1
	57	90	1	72	35	72	95	9	30	76	72	1
	57	105	1,1	-	-	-	-	-	-	85	75	1
	57	105	1,1	80	30	80	110	11,5	42	85	80	1
	57	120	1,5	-	-	-	-	-	-	94	81	1,5



Axial deep groove ball bearings

Single direction

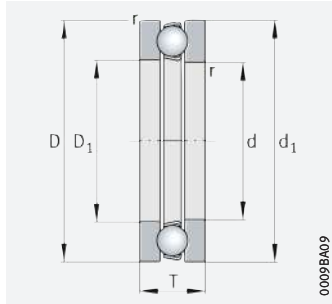

511, 512, 513, 514

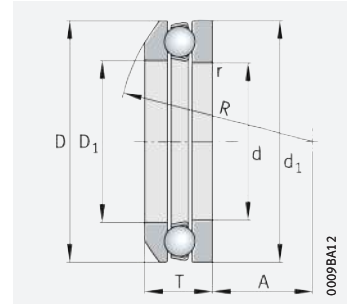

532, 533
Spherical housing locating washer

d = 60 – 80 mm

Main dimensions			Basic load ratings		Fatigue limit load	Minimum load factor	Limiting speed	Speed rating	Mass m		Designation	
d	D	T	dyn. C _a	stat. C _{0a}	C _{ua}	A	n _G	n _{dr}	Bearing ≈ kg	Support washer ≈ kg	Bearing	Support washer
			N	N	N		min ⁻¹	min ⁻¹				
60	85	17	41 500	113 000	5 000	0,065	5 500	4 650	0,278	–	51112	–
	95	26	62 000	139 000	6 200	0,12	4 200	5 300	0,649	–	51212	–
	95	28	62 000	139 000	6 200	0,12	4 200	5 300	0,655	0,163	53212	U212
	110	35	101 000	207 000	9 200	0,28	3 150	5 700	1,36	–	51312	–
	110	38,3	101 000	207 000	9 200	0,28	3 150	5 700	1,41	0,31	53312	U312
	130	51	201 000	395 000	17 700	0,87	2 190	5 500	3,57	–	51412-MP	–
65	90	18	38 500	100 000	4 400	0,063	5 300	4 450	0,3	–	51113	–
	100	27	64 000	149 000	6 600	0,14	4 100	4 900	0,684	–	51213	–
	100	28,7	64 000	149 000	6 600	0,14	4 100	4 900	0,855	0,183	53213	U213
	115	36	105 000	220 000	9 700	0,32	3 050	5 300	1,39	–	51313	–
	115	39,4	105 000	220 000	9 700	0,32	3 050	5 300	1,78	0,34	53313	U313
	140	56	217 000	450 000	19 900	1,1	2 050	5 200	4,47	–	51413-MP	–
70	95	18	40 000	110 000	4 850	0,074	5 100	4 100	0,352	–	51114	–
	105	27	66 000	159 000	7 000	0,16	4 000	4 550	0,727	–	51214	–
	105	28,8	66 000	159 000	7 000	0,16	4 000	4 550	0,903	0,185	53214	U214
	125	40	134 000	290 000	12 900	0,51	2 750	4 950	1,9	–	51314	–
	125	44,2	134 000	290 000	12 900	0,51	2 750	4 950	2,09	0,4	53314	U314
	150	60	222 000	500 000	21 100	1,4	1 920	5 000	5,49	–	51414-MP	–
75	100	19	44 500	123 000	5 500	0,093	4 800	3 800	0,365	–	51115	–
	110	27	67 000	169 000	7 500	0,18	3 950	4 300	0,825	–	51215	–
	110	28,3	67 000	169 000	7 500	0,18	3 950	4 300	1,01	0,21	53215	U215
	135	44	163 000	360 000	15 400	0,75	2 480	4 650	2,59	–	51315	–
	135	48,1	163 000	360 000	15 400	0,75	2 480	4 650	3,19	0,54	53315	U315
	160	65	238 000	560 000	22 700	1,8	1 810	4 750	6,82	–	51415-MP	–
80	105	19	45 000	129 000	5 700	0,1	4 650	3 600	0,384	–	51116	–
	115	28	75 000	191 000	8 500	0,23	3 700	3 950	0,908	–	51216	–
	115	29,5	75 000	191 000	8 500	0,23	3 700	3 950	0,903	0,22	53216	U216
	140	44	160 000	360 000	15 100	0,79	2 460	4 450	2,69	–	51316	–
	140	47,6	160 000	360 000	15 100	0,79	2 460	4 450	2,75	0,56	53316	U316
	170	68	270 000	620 000	24 600	2,2	1 710	4 550	7,97	–	51416-MP	–

medias ► <https://www.schaeffler.de/std/1E15>

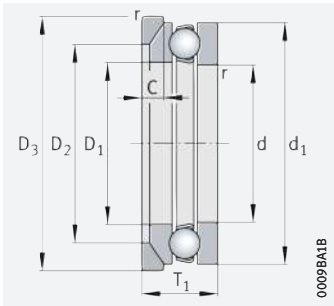

532, 533
Spherical housing locating washer
Support washer U2, U3

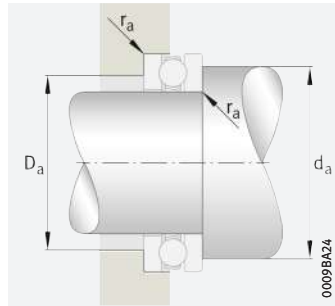

Mounting dimensions

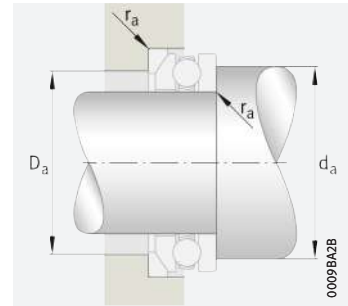

Mounting dimensions

Dimensions

Mounting dimensions

d	D ₁	d ₁	r	R	A	D ₂	D ₃	C	T ₁	Mounting dimensions		
										d _a	D _a	r _a
										min.	max.	max.
60	62	85	1	–	–	–	–	–	–	75	70	1
	62	95	1	–	–	–	–	–	–	81	74	1
	62	95	1	72	32,5	78	100	9	31	81	78	1
	62	110	1,1	–	–	–	–	–	–	90	80	1
	62	110	1,1	90	41	85	115	11,5	42	90	85	1
	62	130	1,5	–	–	–	–	–	–	102	88	1,5
65	67	90	1	–	–	–	–	–	–	80	75	1
	67	100	1	–	–	–	–	–	–	86	79	1
	67	100	1	80	40	82	105	9	32	86	82	1
	67	115	1,1	–	–	–	–	–	–	95	85	1
	67	115	1,1	90	38,5	90	120	12,5	43	95	90	1
	68	140	2	–	–	–	–	–	–	110	95	2
70	72	95	1	–	–	–	–	–	–	85	80	1
	72	105	1	–	–	–	–	–	–	91	84	1
	72	105	1	80	38	88	110	9	32	91	88	1
	72	125	1,1	–	–	–	–	–	–	103	92	1
	72	125	1,1	100	43	98	130	13	48	103	98	1
	73	150	2	–	–	–	–	–	–	118	102	2
75	77	100	1	–	–	–	–	–	–	90	85	1
	77	110	1	–	–	–	–	–	–	96	89	1
	77	110	1	90	49	92	115	9,5	32	96	92	1
	77	135	1,5	–	–	–	–	–	–	111	99	1,5
	77	135	1,5	100	37	105	140	15	52	111	105	1,5
	78	160	2	–	–	–	–	–	–	126	109	2
80	82	105	1	–	–	–	–	–	–	95	90	1
	82	115	1	–	–	–	–	–	–	101	94	1
	82	115	1	90	46	98	120	10	33	101	98	1
	82	140	1,5	–	–	–	–	–	–	116	104	1,5
	82	140	1,5	112	50	110	145	15	52	116	110	1,5
	83	170	2,1	–	–	–	–	–	–	134	116	2,1



Axial deep groove ball bearings

Single direction

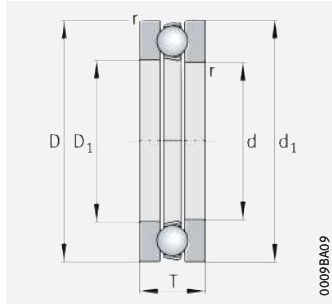

511, 512, 513, 514

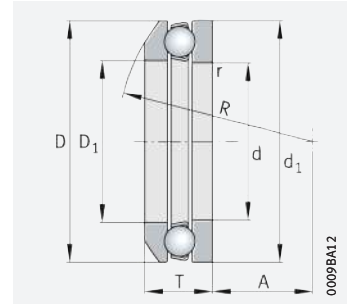

532, 533
Spherical housing locating washer

d = 85 – 120 mm

Main dimensions			Basic load ratings		Fatigue limit load C_{ua} N	Minimum load factor A	Limiting speed n_G min ⁻¹	Speed rating $n_{\theta r}$ min ⁻¹	Mass m		Designation	
d	D	T	dyn. C_a N	stat. C_{0a} N					Bearing ≈ kg	Support washer ≈ kg	Bearing	Support washer
85	110	19	45 500	134 000	6 000	0,11	4 500	3 400	0,404	–	51117	–
	125	31	98 000	250 000	10 900	0,37	3 250	3 850	1,21	–	51217	–
	125	33,1	98 000	250 000	10 900	0,37	3 250	3 850	1,22	0,29	53217	U217
	150	49	186 000	420 000	17 200	1,1	2 260	4 250	3,48	–	51317	–
	150	53,1	186 000	420 000	17 200	1,1	2 260	4 250	3,51	0,8	53317	U317
	180	72	305 000	750 000	29 000	3	1 620	4 250	9,3	–	51417-MP	–
90	120	22	45 500	140 000	6 100	0,12	4 300	3 500	0,617	–	51118	–
	135	35	119 000	300 000	12 600	0,54	2 900	3 750	1,66	–	51218	–
	135	38,5	119 000	300 000	12 600	0,54	2 900	3 750	1,7	0,42	53218	U218
	155	50	193 000	455 000	18 300	1,2	2 240	4 050	3,75	–	51318	–
	155	54,6	193 000	455 000	18 300	1,2	2 240	4 050	3,81	0,82	53318	U318
	190	77	325 000	830 000	31 000	3,7	1 540	4 100	11,2	–	51418-MP	–
100	135	25	85 000	270 000	10 900	0,36	3 500	3 100	0,992	–	51120	–
	150	38	119 000	325 000	12 900	0,68	2 700	3 600	2,21	–	51220	–
	150	40,9	119 000	325 000	12 900	0,68	2 700	3 600	2,23	0,5	53220	U220
	170	55	238 000	580 000	22 600	1,9	1 970	3 650	4,94	–	51320	–
	170	59,2	238 000	580 000	22 600	1,9	1 970	3 650	4,99	0,93	53320	U320
	210	85	375 000	1 060 000	37 500	6	1 350	3 650	15	–	51420-MP	–
110	145	25	87 000	290 000	11 300	0,42	3 350	2 800	1,08	–	51122	–
	160	38	126 000	365 000	14 000	0,83	2 650	3 250	2,28	–	51222	–
	160	40,2	126 000	365 000	14 000	0,83	2 650	3 250	2,24	0,56	53222	U222
	190	63	280 000	740 000	27 000	3	1 790	3 400	7,85	–	51322-MP	–
	190	67,2	280 000	740 000	27 000	3	1 790	3 400	7,85	1,26	53322-MP	U322
	230	95	405 000	1 130 000	38 500	7,1	1 300	3 400	20,02	–	51422-MP	–
120	155	25	89 000	310 000	11 600	0,49	3 200	2 600	1,16	–	51124	–
	170	39	128 000	385 000	14 200	0,94	2 550	3 000	2,66	–	51224	–
	170	40,8	128 000	385 000	14 200	0,94	2 550	3 000	2,58	0,65	53224	U224
	210	70	325 000	910 000	31 500	4,4	1 610	3 200	10,7	–	51324-MP	–
	210	74,1	325 000	910 000	31 500	4,4	1 610	3 200	10,6	2,01	53324-MP	U324
	250	102	455 000	1 340 000	43 500	10	1 180	3 050	25,4	–	51424-MP	–

medias ► <https://www.schaeffler.de/std/1E16>

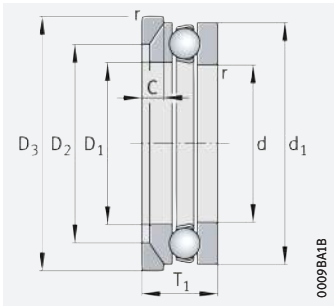

532, 533
Spherical housing locating washer
Support washer U2, U3

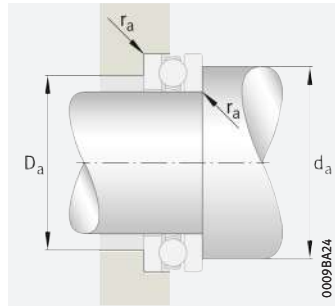

Mounting dimensions

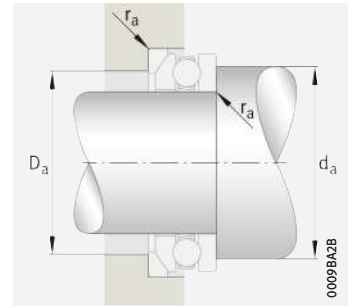

Mounting dimensions

Dimensions										Mounting dimensions		
d	D ₁	d ₁	r	R	A	D ₂	D ₃	C	T ₁	d _a	D _a	r _a
			min.							min.	max.	max.
85	87	110	1	–	–	–	–	–	–	100	95	1
	88	125	1	–	–	–	–	–	–	109	101	1
	88	125	1	100	52	105	130	11	37	109	105	1
	88	150	1,5	–	–	–	–	–	–	124	111	1,5
	88	150	1,5	112	43	115	155	17,5	58	124	115	1,5
	88	177	2,1	–	–	–	–	–	–	142	123	2,1
90	92	120	1	–	–	–	–	–	–	108	102	1
	93	135	1,1	–	–	–	–	–	–	117	108	1
	93	135	1,1	100	45	110	140	13,5	42	117	110	1
	93	155	1,5	–	–	–	–	–	–	129	116	1,5
	93	155	1,5	112	40	120	160	18	59	129	120	1,5
	93	187	2,1	–	–	–	–	–	–	150	130	2,1
100	102	135	1	–	–	–	–	–	–	121	114	1
	103	150	1,1	–	–	–	–	–	–	130	120	1
	103	150	1,1	112	52	125	155	14	45	130	125	1
	103	170	1,5	–	–	–	–	–	–	142	128	1,5
	103	170	1,5	125	46	135	175	18	64	142	135	1,5
	103	205	3	–	–	–	–	–	–	166	144	2,5
110	112	145	1	–	–	–	–	–	–	131	124	1
	113	160	1,1	–	–	–	–	–	–	140	130	1
	113	160	1,1	125	65	135	165	14	45	140	135	1
	113	187	2	–	–	–	–	–	–	158	142	2
	113	187	2	140	51	150	195	20,5	72	158	150	2
	113	225	3	–	–	–	–	–	–	182	158	2,5
120	122	155	1	–	–	–	–	–	–	141	134	1
	123	170	1,1	–	–	–	–	–	–	150	140	1
	123	170	1,1	125	61	145	175	15	46	150	145	1
	123	205	2,1	–	–	–	–	–	–	174	156	2,1
	123	205	2,1	160	63	165	220	22	80	174	165	2,1
	123	245	4	–	–	–	–	–	–	198	172	3



Axial deep groove ball bearings

Single direction

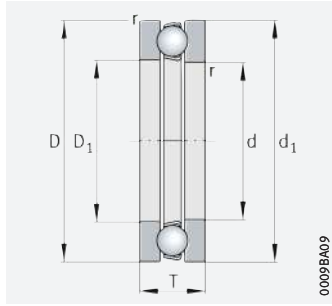

511, 512, 513, 514

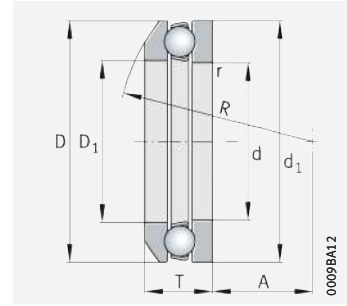

532, 533
Spherical housing locating washer

d = 130 – 180 mm

Main dimensions			Basic load ratings		Fatigue limit load	Minimum load factor	Limiting speed	Speed rating	Mass m		Designation	
d	D	T	dyn. C _a	stat. C _{0a}	C _{ua}	A	n _G	n _{dr}	Bearing ≈ kg	Support washer ≈ kg	Bearing	Support washer
			N	N	N		min ⁻¹	min ⁻¹				
130	170	30	111 000	390 000	14 200	0,76	2 850	2 490	1,75	–	51126	–
	190	45	184 000	540 000	18 900	1,7	2 210	2 850	3,96	–	51226	–
	190	47,9	184 000	540 000	18 900	1,7	2 210	2 850	3,9	0,9	53226	U226
	225	75	360 000	1 050 000	35 000	5,9	1 490	2 950	13	–	51326-MP	–
	270	110	560 000	1 750 000	55 000	16	1 030	2 650	32,02	–	51426-MP	–
140	180	31	111 000	400 000	14 200	0,83	2 750	2 330	1,9	–	51128	–
	200	46	191 000	570 000	19 200	1,9	2 110	2 700	4,3	–	51228	–
	200	48,6	191 000	570 000	19 200	1,9	2 110	2 700	4,25	1,22	53228	U228
	240	80	385 000	1 240 000	40 000	8,2	1 360	2 700	15,6	–	51328-MP	–
	240	84,9	385 000	1 240 000	40 000	8,2	1 360	2 700	15,548	2,92	53328-MP	U328
150	190	31	109 000	400 000	13 800	0,89	2 650	2 200	2,17	–	51130-MP	–
	215	50	236 000	730 000	24 200	2,9	1 950	2 500	6,08	–	51230-MP	–
	215	53,3	236 000	730 000	24 200	2,9	1 950	2 500	5,95	1,69	53230-MP	U230
	250	80	395 000	1 330 000	41 500	9,3	1 340	2 480	16,2	–	51330-MP	–
	250	83,7	395 000	1 330 000	41 500	9,3	1 340	2 480	12,8	3,11	53330-MP	U330
160	200	31	112 000	425 000	14 200	1	2 550	2 060	2,29	–	51132-MP	–
	225	51	240 000	770 000	24 700	3,2	1 900	2 350	6,53	–	51232-MP	–
	225	54,7	240 000	770 000	24 700	3,2	1 900	2 350	6,45	1,8	53232-MP	U232
	270	87	445 000	1 560 000	47 000	13	1 230	2 280	21,2	–	51332-MP	–
	270	91,7	445 000	1 560 000	47 000	13	1 230	2 280	20,814	4	53332-MP	U332
170	215	34	127 000	510 000	16 200	1,4	2 330	2 010	3,02	–	51134-MP	–
	240	55	285 000	930 000	28 500	4,5	1 740	2 230	8,12	–	51234-MP	–
	240	58,7	285 000	930 000	28 500	4,5	1 740	2 230	7,91	2,14	53234-MP	U234
	280	87	440 000	1 560 000	46 000	13	1 220	2 170	22,2	–	51334-MP	–
	280	91,3	440 000	1 560 000	46 000	13	1 220	2 170	21,584	4,42	53334-MP	U334
180	225	34	127 000	520 000	16 300	1,5	2 250	1 910	3,06	–	51136-MP	–
	250	56	305 000	1 030 000	31 500	5,4	1 670	2 080	8,56	–	51236-MP	–
	250	58,2	305 000	1 030 000	31 500	5,4	1 670	2 080	8,19	2,33	53236-MP	U236
	300	95	520 000	1 830 000	52 000	18	1 130	2 000	24,8	–	51336-MP	–
	300	99,3	520 000	1 830 000	52 000	18	1 130	2 000	24,065	5,32	53336-MP	U336

medias ► <https://www.schaeffler.de/std/1E17>

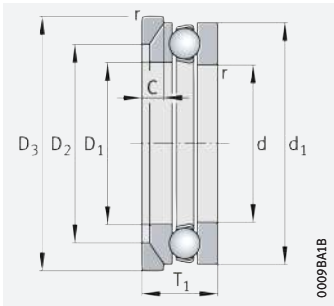

532, 533
Spherical housing locating washer
Support washer U2, U3

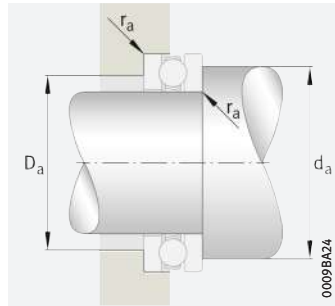

Mounting dimensions

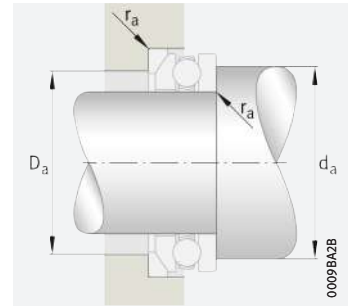

Mounting dimensions

Dimensions

Mounting dimensions

d	D ₁	d ₁	r	R	A	D ₂	D ₃	C	T ₁	Mounting dimensions		
										d _a	D _a	r _a
										min.	max.	max.
130	132	170	1	–	–	–	–	–	–	154	146	1
	133	187	1,5	–	–	–	–	–	–	166	154	1,5
	133	187	1,5	140	67	160	195	17	53	166	160	1,5
	134	220	2,1	–	–	–	–	–	–	187	168	2,1
	134	265	4	–	–	–	–	–	–	214	186	3
140	142	178	1	–	–	–	–	–	–	164	156	1
	143	197	1,5	–	–	–	–	–	–	176	164	1,5
	143	197	1,5	160	87	170	210	17	55	176	170	1,5
	144	235	2,1	–	–	–	–	–	–	200	180	2,1
	144	235	2,1	180	68	190	250	26	92	200	190	2,1
150	152	188	1	–	–	–	–	–	–	174	166	1
	153	212	1,5	–	–	–	–	–	–	189	176	1,5
	153	212	1,5	160	79	180	225	20,5	60	189	180	1,5
	154	245	2,1	–	–	–	–	–	–	210	190	2,1
	154	245	2,1	200	89,5	200	260	26	92	210	200	2,1
160	162	198	1	–	–	–	–	–	–	184	176	1
	163	222	1,5	–	–	–	–	–	–	199	186	1,5
	163	222	1,5	160	74	190	235	21	61	199	190	1,5
	164	265	3	–	–	–	–	–	–	226	204	2,5
	164	265	3	200	77	215	280	29	100	226	215	2,5
170	172	213	1,1	–	–	–	–	–	–	197	188	1
	173	237	1,5	–	–	–	–	–	–	212	198	1,5
	173	237	1,5	180	91	200	250	21,5	65	212	200	1,5
	174	275	3	–	–	–	–	–	–	236	214	2,5
	174	275	3	225	105	220	290	29	100	236	220	2,5
180	183	222	1,1	–	–	–	–	–	–	207	198	1
	183	245	1,5	–	–	–	–	–	–	222	208	1,5
	183	245	1,5	200	112	210	260	21,5	66	222	210	1,5
	184	295	3	–	–	–	–	–	–	252	228	2,5
	184	295	3	225	91	240	310	32	109	252	240	2,5



Axial deep groove ball bearings

Single direction

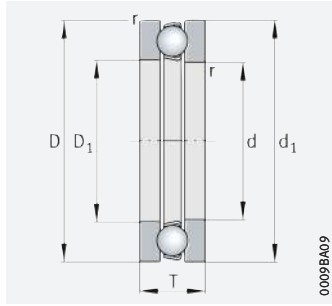

511, 512, 513

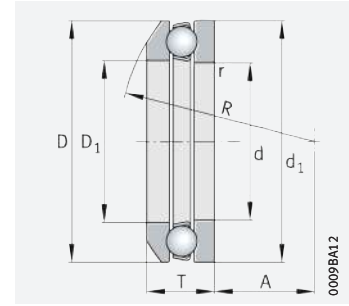

532, 533
Spherical housing locating washer

d = 190 – 260 mm

Main dimensions			Basic load ratings		Fatigue limit load	Minimum load factor	Limiting speed	Speed rating	Mass m		Designation	
d	D	T	dyn. C _a N	stat. C _{0a} N	C _{ua} N	A	n _G min ⁻¹	n _{dr} min ⁻¹	Bearing ≈ kg	Support washer ≈ kg	Bearing	Support washer
190	240	37	161 000	650 000	19 700	2,3	2 040	1 850	4,06	–	51138-MP	–
	270	62	335 000	1 170 000	34 500	7,2	1 540	2 010	11,6	–	51238-MP	–
	270	65,7	335 000	1 170 000	34 500	7,2	1 540	2 010	11,5	2,63	53238-MP	U238
	320	105	590 000	2 170 000	61 000	24	1 040	1 840	36,736	–	51338-MP	–
	320	111	590 000	2 170 000	61 000	24	1 040	1 840	36,479	6,16	53338-MP	U338
200	250	37	162 000	670 000	19 800	2,5	1 980	1 760	4,12	–	51140-MP	–
	280	62	340 000	1 220 000	35 000	7,8	1 510	1 890	12	–	51240-MP	–
	280	65,3	340 000	1 220 000	35 000	7,8	1 510	1 890	11,819	2,79	53240-MP	U240
220	270	37	168 000	730 000	20 700	3	1 870	1 600	4,54	–	51144-MP	–
	300	63	335 000	1 330 000	36 500	9,6	1 420	1 690	13,1	–	51244-MP	–
	300	65,6	335 000	1 330 000	36 500	9,6	1 420	1 690	13,114	3,31	53244-MP	U244
240	300	45	237 000	990 000	27 000	5,2	1 640	1 540	7,41	–	51148-MP	–
260	320	45	245 000	1 070 000	28 000	6,1	1 560	1 390	7,89	–	51152-MP	–

medias ► <https://www.schaeffler.de/std/1E18>

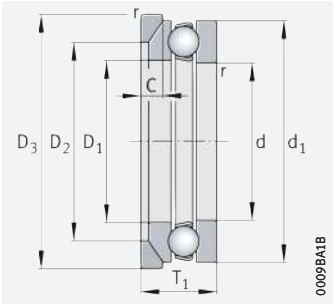

532, 533
Spherical housing locating washer
Support washer U2, U3

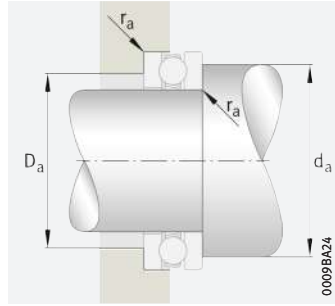

Mounting dimensions

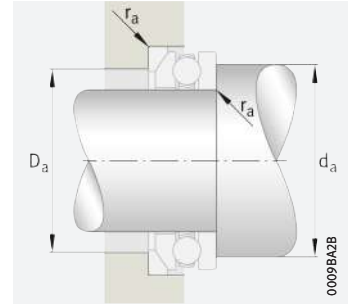

Mounting dimensions



Dimensions

Mounting dimensions

d	D ₁	d ₁	r	R	A	D ₂	D ₃	C	T ₁	d _a	D _a	r _a
			min.							min.	max.	max.
190	193	237	1,1	–	–	–	–	–	–	220	210	1
	194	265	2	–	–	–	–	–	–	238	222	2
	195	265	2	200	98	230	280	23	73	238	230	2
	195	315	4	–	–	–	–	–	–	268	242	3
	195	315	4	250	104	255	330	33	121	268	255	3
200	203	247	1,1	–	–	–	–	–	–	230	220	1
	204	275	2	–	–	–	–	–	–	248	232	2
	204	275	2	225	125	240	290	23	74	248	240	2
220	223	267	1,1	–	–	–	–	–	–	250	240	1
	224	295	2	–	–	–	–	–	–	268	252	2
	224	295	2	225	118	260	310	25	75	268	260	2
240	243	297	1,5	–	–	–	–	–	–	276	264	1,5
260	263	317	1,5	–	–	–	–	–	–	296	284	1,5



Axial deep groove ball bearings

Double direction

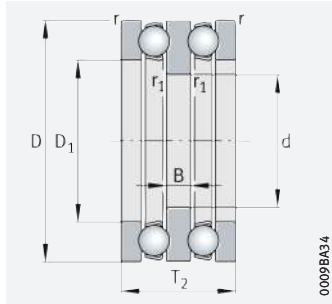

522, 523

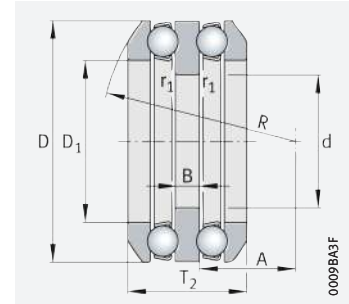

542, 543
Spherical housing locating washers

d = 10 – 40 mm

Main dimensions			Basic load ratings		Fatigue limit load	Minimum load factor	Limiting speed	Speed rating	Mass m		Designation	
d	D	T ₂	dyn. C _a	stat. C _{0a}	C _{ua}	A	n _G	n _{0r}	Bearing	Support washer	Bearing	Support washer
			N	N	N		min ⁻¹	min ⁻¹	≈ kg	≈ kg		
10	32	22	16 600	24 800	1 100	0,003	9 800	13 700	0,085	–	52202	–
15	40	26	21 100	37 500	1 660	0,007	8 500	11 100	0,15	–	52204	–
20	47	28	26 500	50 000	2 220	0,013	7 500	9 400	0,23	–	52205	–
	47	31,4	26 500	50 000	2 220	0,013	7 500	9 400	0,221	0,031	54205	U205
	52	34	34 500	55 000	2 450	0,019	6 000	9 700	0,29	–	52305	–
	52	37,6	34 500	55 000	2 450	0,019	6 000	9 700	0,303	0,043	54305	U305
	70	52	70 000	112 000	5 000	0,077	3 850	8 700	0,912	–	52406	–
25	52	29	23 900	46 000	2 040	0,014	7 300	8 200	0,249	–	52206	–
	52	32,6	23 900	46 000	2 040	0,014	7 300	8 200	0,269	0,032	54206	U206
	60	38	35 500	65 000	2 850	0,028	5 700	8 600	0,435	–	52306	–
	60	41,2	35 500	65 000	2 850	0,028	5 700	8 600	0,553	0,055	54306	U306
	80	59	76 000	126 000	5 600	0,11	3 600	8 000	1,44	–	52407	–
30	62	34	35 500	67 000	3 000	0,028	6 000	7 500	0,405	–	52207	–
	62	37,8	35 500	67 000	3 000	0,028	6 000	7 500	0,423	0,082	54207	U207
	68	36	44 000	97 000	4 300	0,05	5 500	6 900	0,54	–	52208	–
	68	44	50 000	89 000	3 900	0,05	4 850	7 600	0,63	–	52307	–
	68	38,6	44 000	97 000	4 300	0,05	5 500	6 900	0,513	0,07	54208	U208
	68	47,2	50 000	89 000	3 900	0,05	4 850	7 600	0,683	0,082	54307	U307
	78	49	61 000	112 000	5 000	0,081	4 250	7 200	1,02	–	52308	–
	78	54	61 000	112 000	5 000	0,081	4 250	7 200	1,1	0,114	54308	U308
	90	65	96 000	170 000	7 500	0,18	3 250	7 100	2,03	–	52408	–
	35	73	37	39 000	80 000	3 550	0,043	5 500	6 500	0,58	–	52209
73		39,6	39 000	80 000	3 550	0,043	5 500	6 500	0,537	0,087	54209	U209
85		52	75 000	140 000	6 300	0,12	3 800	6 500	1,236	–	52309	–
85		56,2	75 000	140 000	6 300	0,12	3 800	6 500	1,28	0,171	54309	U309
100		72	123 000	222 000	9 800	0,29	2 850	6 500	2,71	–	52409	–
40	78	39	50 000	106 000	4 700	0,069	4 950	5 800	0,684	–	52210	–
	78	42	50 000	106 000	4 700	0,069	4 950	5 800	0,625	0,098	54210	U210
	95	58	82 000	169 000	7 500	0,18	3 550	6 100	1,76	–	52310	–
	95	64,6	82 000	169 000	7 500	0,18	3 550	6 100	1,84	0,22	54310	U310
	110	78	138 000	255 000	11 400	0,4	2 650	6 000	3,56	–	52410	–

medias ► <https://www.schaeffler.de/std/1E19>

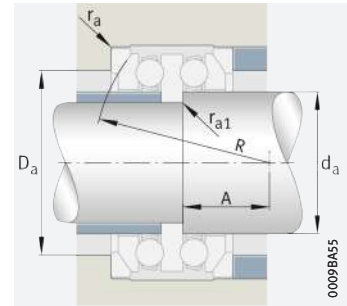
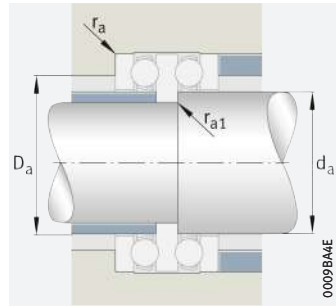
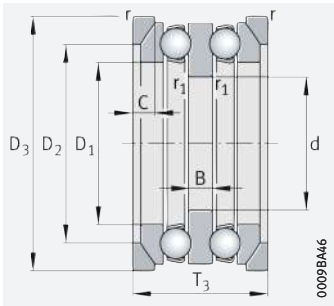

542, 543
Spherical housing locating washers
Support washers U2, U3

Mounting dimensions

Mounting dimensions

Dimensions											Mounting dimensions			
d	D ₁	B	r	r ₁	R	A	D ₂	D ₃	C	T ₃	d _a	D _a	r _a	r _{a1}
			min.	min.								max.	max.	max.
10	17	5	0,6	0,3	-	-	-	-	-	-	15	22	0,6	0,3
15	22	6	0,6	0,3	-	-	-	-	-	-	20	28	0,6	0,3
20	27	7	0,6	0,3	-	-	-	-	-	-	25	34	0,6	0,3
	27	7	0,6	0,3	40	16,5	36	50	5,5	36	25	36	0,6	0,3
	27	8	1	0,3	-	-	-	-	-	-	25	36	1	0,3
	27	8	1	0,3	45	18	42	55	6	38	25	38	1	0,3
	32	12	1	0,6	-	-	-	-	-	-	-	30	46	1
25	32	7	0,6	0,3	-	-	-	-	-	-	30	39	0,6	0,3
	32	7	0,6	0,3	45	20	37	55	5,5	42	30	42	0,6	0,3
	32	9	1	0,3	-	-	-	-	-	-	30	42	1	0,3
	32	9	1	0,3	50	19,5	46	62	7	45	30	45	1	0,3
	37	14	1,1	0,6	-	-	-	-	-	-	35	53	1	0,6
30	37	8	1	0,3	-	-	-	-	-	-	35	46	1	0,3
	37	8	1	0,3	50	21	42	72	7,5	52	35	48	1	0,3
	42	9	1	0,6	-	-	-	-	-	-	40	51	1	0,6
	37	10	1	0,3	-	-	-	-	-	-	35	48	1	0,3
	42	9	1	0,6	56	25	44	72	7	55	40	55	1	0,6
	37	10	1	0,3	56	21	52	72	7,5	52	35	52	1	0,3
	42	12	1	0,6	-	-	-	-	-	-	40	55	1	0,6
	42	12	1	0,6	64	23,5	59	82	8,5	60	40	60	1	0,6
	42	15	1,1	0,6	-	-	-	-	-	-	40	60	1	0,6
35	47	9	1	0,6	-	-	-	-	-	-	45	56	1	0,6
	47	9	1	0,6	56	23	45	78	7,5	60	45	60	1	0,6
	47	12	1	0,6	-	-	-	-	-	-	45	61	1	0,6
	47	12	1	0,6	64	21	62	90	10	65	45	65	1	0,6
	47	17	1,1	0,6	-	-	-	-	-	-	45	67	1	0,6
40	52	9	1	0,6	-	-	-	-	-	-	50	61	1	0,6
	52	9	1	0,6	64	30,5	47	82	7,5	62	50	62	1	0,6
	52	14	1,1	0,6	-	-	-	-	-	-	50	68	1	0,6
	52	14	1,1	0,6	72	23	70	100	11	72	50	72	1	0,6
	52	18	1,5	0,6	-	-	-	-	-	-	50	74	1,5	0,6

Axial deep groove ball bearings

Double direction

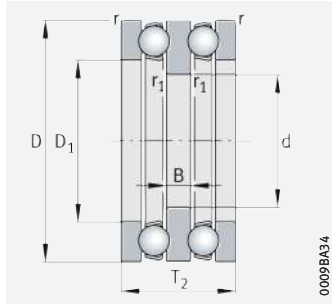

522, 523

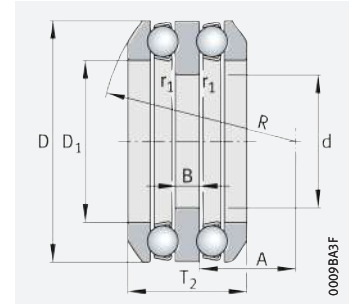

542, 543
Spherical housing locating washers

d = 45 – 70 mm

Main dimensions			Basic load ratings		Fatigue limit load	Minimum load factor	Limiting speed	Speed rating	Mass m		Designation	
d	D	T ₂	dyn. C _a N	stat. C _{0a} N	C _{ua} N	A	n _G min ⁻¹	n _{Dr} min ⁻¹	Bearing ≈ kg	Support washer ≈ kg	Bearing	Support washer
45	90	45	58 000	133 000	5 900	0,11	4 350	5 600	1,054	–	52211	–
	90	49,6	58 000	133 000	5 900	0,11	4 350	5 600	1,02	0,152	54211	U211
	105	64	102 000	207 000	9 200	0,26	3 200	5 700	2,37	–	52311	–
	105	72,6	102 000	207 000	9 200	0,26	3 200	5 700	2,53	0,27	54311	U311
	120	87	167 000	315 000	14 000	0,59	2 340	5 600	4,7	–	52411	–
50	95	46	62 000	139 000	6 200	0,12	4 200	5 200	1,1	–	52212	–
	95	50	62 000	139 000	6 200	0,12	4 200	5 200	1,17	0,163	54212	U212
	110	64	101 000	207 000	9 200	0,28	3 150	5 400	2,49	–	52312	–
	110	70,6	101 000	207 000	9 200	0,28	3 150	5 400	2,59	0,31	54312	U312
	115	70,6	101 000	207 000	9 200	0,28	3 150	5 800	2,98	0,34	54313	U313
55	100	47	64 000	149 000	6 600	0,14	4 100	4 800	1,281	–	52213	–
	100	50,4	64 000	149 000	6 600	0,14	4 100	4 800	1,53	0,183	54213	U213
	105	47	66 000	159 000	7 000	0,16	4 000	4 750	1,401	–	52214	–
	105	50,6	66 000	159 000	7 000	0,16	4 000	4 750	1,46	0,185	54214	U214
	115	65	105 000	220 000	9 700	0,32	3 050	5 000	2,68	–	52313	–
	125	72	134 000	290 000	12 900	0,51	2 750	4 800	3,55	–	52314	–
	125	80,4	134 000	290 000	12 900	0,51	2 750	4 800	3,77	0,4	54314	U314
60	110	47	67 000	169 000	7 500	0,18	3 950	4 450	1,45	–	52215	–
	110	49,6	67 000	169 000	7 500	0,18	3 950	4 450	1,87	0,21	54215	U215
	135	79	163 000	360 000	15 400	0,75	2 480	4 500	4,72	–	52315	–
	135	87,2	163 000	360 000	15 400	0,75	2 480	4 500	4,98	0,54	54315	U315
65	115	48	75 000	191 000	8 500	0,23	3 700	4 150	1,55	–	52216	–
	115	51	75 000	191 000	8 500	0,23	3 700	4 150	1,6	0,22	54216	U216
	140	79	160 000	360 000	15 100	0,79	2 460	4 350	4,82	–	52316	–
	140	86,2	160 000	360 000	15 100	0,79	2 460	4 350	5,22	0,56	54316	U316
70	125	55	98 000	250 000	10 900	0,37	3 250	3 950	2,23	–	52217	–
	125	59,2	98 000	250 000	10 900	0,37	3 250	3 950	2,25	0,29	54217	U217
	150	87	186 000	420 000	17 200	1,1	2 260	4 150	6,2	–	52317	–
	150	95,2	186 000	420 000	17 200	1,1	2 260	4 150	6,41	0,8	54317	U317

medias ► <https://www.schaeffler.de/std/1E1A>

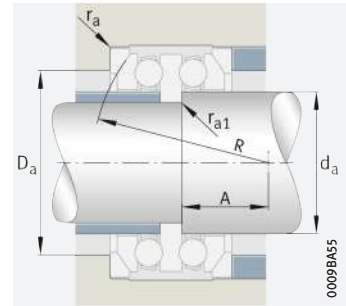
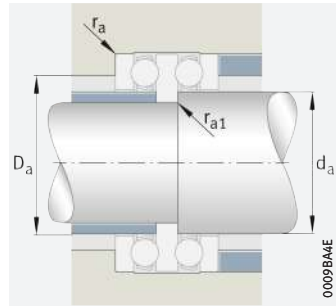
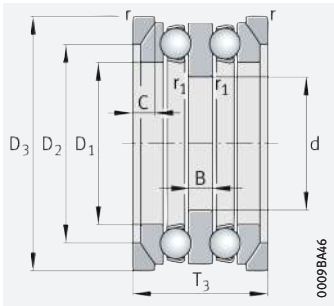

542, 543
Spherical housing locating washers
Support washers U2, U3

Mounting dimensions

Mounting dimensions

Dimensions											Mounting dimensions			
d	D ₁	B	r	r ₁	R	A	D ₂	D ₃	C	T ₃	d _a	D _a	r _a	r _{a1}
			min.	min.								max.	max.	max.
45	57	10	1	0,6	–	–	–	–	–	–	55	69	1	0,6
	57	10	1	0,6	72	32,5	55	95	9	72	55	72	1	0,6
	57	15	1,1	0,6	–	–	–	–	–	–	55	75	1	0,6
	57	15	1,1	0,6	80	25,5	78	110	11,5	80	55	80	1	0,6
	57	20	1,5	0,6	–	–	–	–	–	–	55	81	1,5	0,6
50	62	10	1	0,6	–	–	–	–	–	–	60	74	1	0,6
	62	10	1	0,6	72	30,5	56	100	9	78	60	78	1	0,6
	62	15	1,1	0,6	–	–	–	–	–	–	60	80	1	0,6
	62	15	1,1	0,6	90	36,5	78	115	11,5	85	60	85	1	0,6
	67	15	1,1	0,6	90	34,5	79	120	12,5	90	60	85	1	0,6
55	67	10	1	0,6	–	–	–	–	–	–	65	79	1	0,6
	67	10	1	0,6	80	38,5	57	105	9	82	65	82	1	0,6
	72	10	1	1	–	–	–	–	–	–	70	84	1	1
	72	10	1	1	80	36,5	57	110	9	88	70	88	1	1
	67	15	1,1	0,6	–	–	–	–	–	–	65	85	1	0,6
	72	16	1,1	1	–	–	–	–	–	–	70	92	1	1
	72	16	1,1	1	100	39	88	130	13	98	70	98	1	1
60	77	10	1	1	–	–	–	–	–	–	75	89	1	1
	77	10	1	1	90	47,5	57	115	9,5	92	75	92	1	1
	77	18	1,5	1	–	–	–	–	–	–	75	99	1,5	1
	77	18	1,5	1	100	32,5	95	140	15	105	75	105	1,5	1
65	82	10	1	1	–	–	–	–	–	–	80	94	1	1
	82	10	1	1	90	45	58	120	10	98	80	98	1	1
	82	18	1,5	1	–	–	–	–	–	–	80	104	1,5	1
	82	18	1,5	1	112	45,5	95	145	15	110	80	110	1,5	1
70	88	12	1	1	–	–	–	–	–	–	85	101	1	1
	88	12	1	1	100	49,5	67	130	11	105	85	105	1	1
	88	19	1,5	1	–	–	–	–	–	–	85	111	1,5	1
	88	19	1,5	1	112	39	105	155	17,5	115	85	115	1,5	1



Axial deep groove ball bearings

Double direction

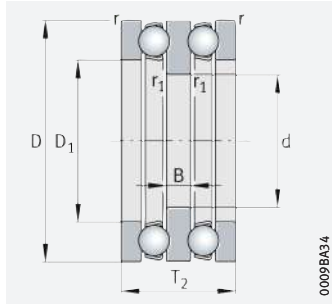

522, 523

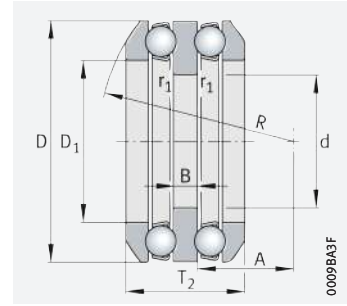

542, 543
Spherical housing locating washers

d = 75 – 130 mm

Main dimensions			Basic load ratings		Fatigue limit load C_{ua} N	Minimum load factor A	Limiting speed n_G min ⁻¹	Speed rating $n_{\theta r}$ min ⁻¹	Mass m		Designation	
d	D	T ₂	dyn. C _a N	stat. C _{0a} N					Bearing ≈ kg	Support washer ≈ kg	Bearing	Support washer
75	135	62	119 000	300 000	12 600	0,54	2 900	3 800	3,05	–	52218	–
	135	69	119 000	300 000	12 600	0,54	2 900	3 800	3,11	0,42	54218	U218
	155	88	193 000	455 000	18 300	1,2	2 240	3 900	6,62	–	52318	–
	155	97,2	193 000	455 000	18 300	1,2	2 240	3 900	6,76	0,82	54318	U318
85	150	67	119 000	325 000	12 900	0,68	2 700	3 550	3,945	–	52220	–
	150	72,8	119 000	325 000	12 900	0,68	2 700	3 550	3,87	0,5	54220	U220
	170	97	238 000	580 000	22 600	1,9	1 970	3 550	8,71	–	52320	–
	170	105,4	238 000	580 000	22 600	1,9	1 970	3 550	8,93	0,93	54320	U320
95	160	67	126 000	365 000	14 000	0,83	2 650	3 250	4,06	–	52222	–
	160	71,4	126 000	365 000	14 000	0,83	2 650	3 250	4,55	0,56	54222	U222
	190	110	280 000	740 000	27 000	3	1 790	3 300	14	–	52322-MP	–
	190	118,4	280 000	740 000	27 000	3	1 790	3 300	13,7	1,26	54322-MP	U322
100	170	68	128 000	385 000	14 200	0,94	2 550	3 100	4,82	–	52224	–
	170	71,6	128 000	385 000	14 200	0,94	2 550	3 100	4,658	0,65	54224	U224
	210	123	325 000	910 000	31 500	4,4	1 610	3 100	19,3	–	52324-MP	–
	210	131,2	325 000	910 000	31 500	4,4	1 610	3 100	18,8	2,01	54324-MP	U324
110	190	80	184 000	540 000	18 900	1,7	2 210	2 950	7,26	–	52226	–
	190	85,8	184 000	540 000	18 900	1,7	2 210	2 950	7,51	0,9	54226	U226
120	200	81	191 000	570 000	19 200	1,9	2 110	2 750	7,9	–	52228	–
	200	86,2	191 000	570 000	19 200	1,9	2 110	2 750	16,91	1,22	54228	U228
	240	140	385 000	1 240 000	40 000	8,2	1 360	2 550	28,3	–	52328-MP	–
130	215	89	236 000	730 000	24 200	2,9	1 950	2 550	11,46	–	52230-MP	–
	215	95,6	236 000	730 000	24 200	2,9	1 950	2 550	10,41	1,69	54230-MP	U230
	250	140	395 000	1 330 000	41 500	9,3	1 340	2 360	29,4	–	52330-MP	–

medias ► <https://www.schaeffler.de/std/1E1B>

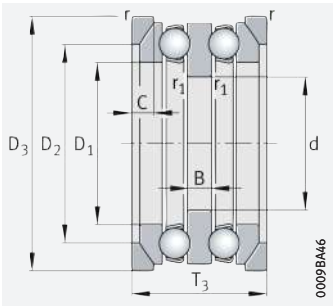

542, 543
Spherical housing locating washers
Support washers U2, U3

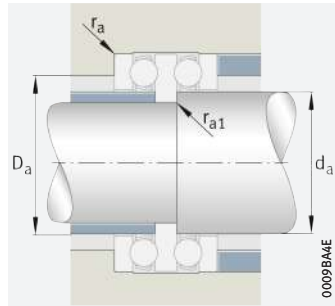

Mounting dimensions

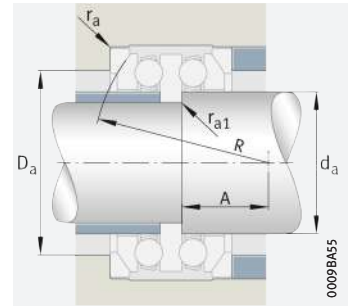

Mounting dimensions

Dimensions

Mounting dimensions

d	D ₁	B	r	r ₁	R	A	D ₂	D ₃	C	T ₃	d _a	D _a	r _a	r _{a1}
			min.	min.								max.	max.	max.
75	93	14	1,1	1	–	–	–	–	–	–	90	108	1	1
	93	14	1,1	1	100	42	76	140	13,5	110	90	110	1	1
	93	19	1,5	1	–	–	–	–	–	–	90	116	1,5	1
	93	19	1,5	1	112	36,5	106	160	18	120	90	120	1,5	1
85	103	15	1,1	1	–	–	–	–	–	–	100	120	1	1
	103	15	1,1	1	112	49	81	155	14	125	100	125	1	1
	103	21	1,5	1	–	–	–	–	–	–	100	128	1,5	1
	103	21	1,5	1	125	42	115	175	18	135	100	135	1,5	1
95	113	15	1,1	1	–	–	–	–	–	–	110	130	1	1
	113	15	1,1	1	125	62	81	165	14	135	110	135	1	1
	113	24	2	1	–	–	–	–	–	–	110	142	2	1
	113	24	2	1	140	47	128	195	20,5	150	110	150	2	1
100	123	15	1,1	1,1	–	–	–	–	–	–	120	140	1	1
	123	15	1,1	1,1	125	58,5	82	175	15	145	120	145	1	1
	123	27	2,1	1,1	–	–	–	–	–	–	120	156	2,1	1
	123	27	2,1	1,1	160	58	143	220	22	165	120	165	2,1	1
110	133	18	1,5	1,1	–	–	–	–	–	–	130	154	1,5	1
	133	18	1,5	1,1	140	63	96	195	17	160	130	160	1,5	1
120	143	18	1,5	1,1	–	–	–	–	–	–	140	164	1,5	1
	143	18	1,5	1,1	160	83,5	99	210	17	170	140	170	1,5	1
	144	31	2,1	1,1	–	–	–	–	–	–	140	180	2,1	1
130	153	20	1,5	1,1	–	–	–	–	–	–	150	176	1,5	1
	153	20	1,5	1,1	160	74,5	109	225	20,5	180	150	180	1,5	1
	154	31	2,1	1,1	–	–	–	–	–	–	150	190	2,1	1



Axial deep groove ball bearings

Double direction

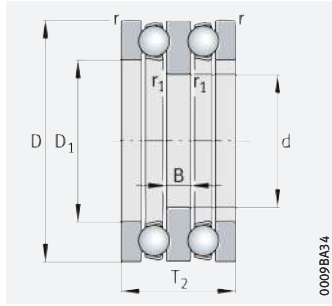

522, 523

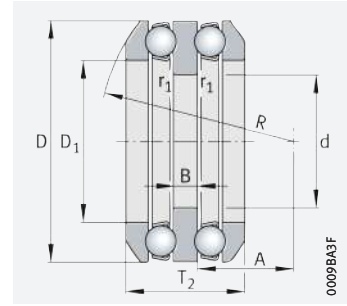

542
Spherical housing locating washers

d = 140 – 190 mm

Main dimensions			Basic load ratings		Fatigue limit load	Minimum load factor	Limiting speed	Speed rating	Mass m		Designation	
d	D	T ₂	dyn. C _a N	stat. C _{0a} N	C _{ua} N	A	n _G min ⁻¹	n _{0r} min ⁻¹	Bearing ≈ kg	Support washer ≈ kg	Bearing	Support washer
140	225	90	240 000	770 000	24 700	3,2	1 900	2 400	12,2	–	52232-MP	–
	225	97,4	240 000	770 000	24 700	3,2	1 900	2 400	11,19	1,8	54232-MP	U232
	270	153	445 000	1 560 000	47 000	13	1 230	2 160	38,2	–	52332-MP	–
150	240	97	285 000	930 000	28 500	4,5	1 740	2 210	14	–	52234-MP	–
	240	104,4	285 000	930 000	28 500	4,5	1 740	2 210	13,59	2,14	54234-MP	U234
	250	98	305 000	1 030 000	31 500	5,4	1 670	2 120	16,2	–	52236-MP	–
	250	102,4	305 000	1 030 000	31 500	5,4	1 670	2 120	15,53	2,33	54236-MP	U236
160	280	153	440 000	1 560 000	46 000	13	1 220	2 060	39,9	–	52334-MP	–
	270	109	335 000	1 170 000	34 500	7,2	1 540	1 990	21,9	–	52238-MP	–
	270	116,4	335 000	1 170 000	34 500	7,2	1 540	1 990	20	2,63	54238-MP	U238
170	320	183	590 000	2 170 000	61 000	24	1 040	1 770	66,4	–	52338-MP	–
	280	109	340 000	1 220 000	35 000	7,8	1 510	1 880	23,2	–	52240-MP	–
170	280	115,6	340 000	1 220 000	35 000	7,8	1 510	1 880	20,97	2,79	54240-MP	U240
	190	300	110	335 000	1 330 000	36 500	9,6	1 420	1 680	25,2	–	52244-MP
300		115,2	335 000	1 330 000	36 500	9,6	1 420	1 680	23	3,31	54244-MP	U244

medias ► <https://www.schaeffler.de/std/1E1C>

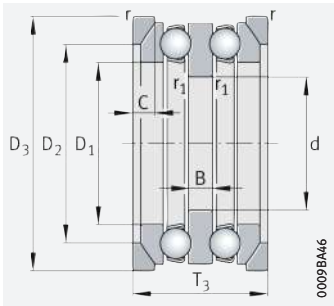

542
Spherical housing locating washers
Support washers U2

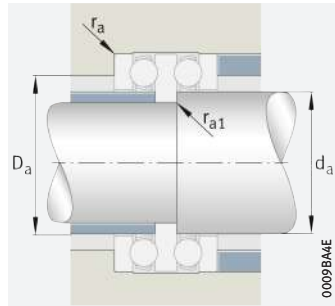

Mounting dimensions

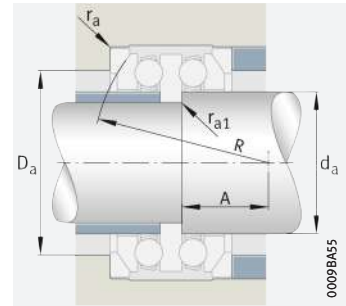

Mounting dimensions

Dimensions											Mounting dimensions			
d	D ₁	B	r	r ₁	R	A	D ₂	D ₃	C	T ₃	d _a	D _a	r _a	r _{a1}
			min.	min.								max.	max.	max.
140	163	20	1,5	1,1	–	–	–	–	–	–	160	186	1,5	1
	163	20	1,5	1,1	160	70	110	235	21	190	160	190	1,5	1
	164	33	3	1,1	–	–	–	–	–	–	160	204	2,5	1
150	173	21	1,5	1,1	–	–	–	–	–	–	170	198	1,5	1
	173	21	1,5	1,1	180	87	117	250	21,5	200	170	200	1,5	1
	183	21	1,5	2	–	–	–	–	–	–	180	208	1,5	1
	183	21	1,5	2	200	108,5	118	260	21,5	210	180	210	1,5	1
160	174	33	3	1,1	–	–	–	–	–	–	170	214	2,5	1
	194	24	2	2	–	–	–	–	–	–	190	222	2	2
	194,7	24	2	2	200	93,5	131	280	23	230	190	230	2	2
170	195	40	4	2	–	–	–	–	–	–	190	242	3	2
	204	24	2	2	–	–	–	–	–	–	200	232	2	2
	204	24	2	2	225	120,5	133	290	23	240	200	240	2	2
190	224	24	2	2	–	–	–	–	–	–	220	252	2	2
	224	24	2	2	225	114	134	310	25	260	220	260	2	2

Axial cylindrical roller bearings



Matrix for bearing preselection 1075

1 Axial cylindrical roller bearings 1076

1.1 Bearing design 1076

1.2 Load carrying capacity 1079

1.3 Compensation of angular misalignments 1079

1.4 Lubrication 1079

1.5 Sealing 1079

1.6 Speeds 1080



1.7	Noise	1080	1.17	Mounting and dismounting	1085
1.8	Temperature range	1080	1.18	Legal notice regarding data freshness	1086
1.9	Cages	1081	1.19	Further information	1086
1.10	Internal clearance	1081	Product tables	1088	
1.11	Dimensions, tolerances	1082	 Axial cylindrical roller bearings, axial cylindrical roller and cage assemblies, axial bearing washers	1088	
1.12	Suffixes	1082			
1.13	Structure of bearing designation	1083			
1.14	Dimensioning	1083			
1.15	Minimum load	1084			
1.16	Design of bearing arrangements	1084			





























Matrix for bearing preselection

The matrix gives an overview of the types and design features of axial cylindrical roller bearings.

It can be used to make a preliminary assessment of whether a bearing is fundamentally suitable for the envisaged application.

The additional information provided in the product chapter (see column "detailed information") and in the Technical principles must, however, be observed in addition to this overview in selection of the bearing.

Design features and suitability			Axial cylindrical roller bearings	
+++ extremely suitable ++ highly suitable + suitable (+) suitable with restrictions – not suitable/not applicable ✓ available			 ▶ 1076	
Load carrying capacity	radial		–	▶1079 1.2
	axial, one direction		++	▶1079 1.2
	axial, both directions		–	▶1079 1.2
	moments		–	
Compensation of angular misalignments	static		–	▶1079 1.3
	dynamic		–	▶1079 1.3
Bearing design	cylindrical bore		✓	▶1076 1.1
	tapered bore		–	
	separable		✓	▶1085 1.17
Lubrication	greased		–	▶1079 1.4
Sealing	open		✓	▶1079 1.5
	non-contact		–	▶1079
	contact		–	▶1079 1.5
Operating temperature in °C		from to 	–20 +120	▶1080 1.8
Suitability for	high speeds		(+)	▶1080 1.6
	high running accuracy		++	▶1082 1.11 ▶114
	low-noise running		(+)	▶1080 1.7 ▶27
	high rigidity		++	▶54
	reduced friction		(+)	▶56
	length compensation within bearing		–	
	non-locating bearing arrangement		–	
	locating bearing arrangement		++	▶139
X-life bearings		X-life	–	
Bearing bore d in mm		from to 	15 320 ¹⁾	▶1088
Product tables			from page 	1088



¹⁾ Larger catalogue bearings
 ▶  GL 1

1 Axial cylindrical roller bearings



Single and double row axial cylindrical roller bearings are particularly suitable where:

- high axial and shock loads occur in one direction but no radial loads are present ► 1076 | 1 and ► 1079 | 1.2
- the load carrying capacity of the corresponding axial deep groove ball bearings is no longer adequate (in this case, bearings of series 811 and 812 are especially suitable) ► 1076 | 1
- the bearing arrangement must have very high axial rigidity
- the axial space available is very small ► 1076 | 1 and ► 1088 | 1
- the bearing arrangement can be configured, where the axial space is very small, as a direct bearing arrangement ► 1076 | 1.1
- the bearing parts can or must be mounted separately
- the bearing arrangement is not configured in itself but, for cost reasons, ready-to-fit standard bearings are to be used.

For an overview of other product-specific features, see the Matrix for bearing preselection ► 1075.

1
Axial cylindrical roller bearing and axial ball bearing – comparison of load carrying capacity and design envelope

F_a = axial load
 C_a = basic dynamic load rating
 D_w = roller diameter
 T = axial section height of axial deep groove ball bearing

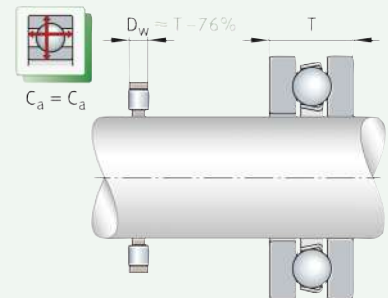
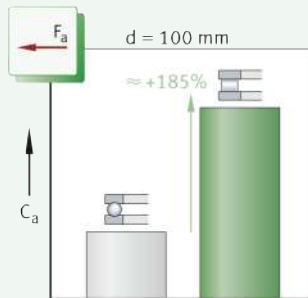

1.1 Bearing design

Design variants

Axial cylindrical roller bearings are available as:

- single and double row bearings
- individual bearing parts for combination, comprising
 - axial cylindrical roller and cage assembly (prefix K)
 - housing locating washer (prefix GS)
 - shaft locating washer (prefix WS)
 - bearing washers (prefix LS, alternatively for shaft and housing locating washer).

Larger catalogue bearings and other bearing designs ► GL 1.

🔗 *Designed for bearing arrangements with very small axial space*

Axial cylindrical roller bearings

Axial cylindrical roller bearings are part of the group of axial roller bearings. In contrast to the ball, the roller has a larger contact area perpendicular to the roller axis. As a result, it can transmit higher forces, has greater rigidity and allows smaller rolling element diameters under the same load. The single and double row bearings comprise flat, ribless washers (housing and shaft locating washers) between which axial cylindrical roller and cage assemblies are arranged ▶1077|📐2 and ▶1078|📐5. Their axial section height T corresponds only to the diameter of the rollers plus the thickness of the washers. Due to this design, the bearings are particularly small in axial height ▶1088|📐. The axial cages are made from brass or plastic and are fitted with one or two rows of cylindrical rollers. Since sliding occurs towards the ends of the rollers during rolling of the rolling elements and this increases with the length of the roller, bearings with a wide cross-section have several short rollers arranged adjacent to each other, e.g. double row designs ▶1077|📐2.



🔗 *Rollers with profiled ends increase the operating life of the bearings*

The cylindrical rollers have profiled ends, i.e. they have a slight lateral curvature towards the ends. This modified line contact between the rollers and raceways prevents damaging edge stresses ▶1077|📐3. This in turn has a positive effect on the operating life of the bearings.



The use of complete axial cylindrical roller bearings (shaft locating washer, axial cylindrical roller and cage assembly and housing locating washer) is then advisable if, for example, high speeds occur and the bearing washers must therefore be centred precisely.

🔗 *Roller and cage assembly and bearing washers are also available individually*

The bearing parts for axial cylindrical roller bearings are also available individually ▶1078|📐4 and ▶1078|📐5. Axial cylindrical roller and cage assemblies (without shaft and housing locating washers) are suitable, for example, for bearing arrangements with very small axial design space.



Cylindrical roller bearings 811 and 812 are of a single row design and correspond to DIN 722:2005 and ISO 104:2015. The bearings 893 and 894 are of a double row design and are configured in accordance with DIN 616:2000 and ISO 104:2015.



Axial cylindrical roller bearings

F_a = axial load

- ① Single row bearing
- ② Double row bearing
- ③ Shaft locating washer
- ④ Housing locating washer
- ⑤ Axial cylindrical roller and cage assembly

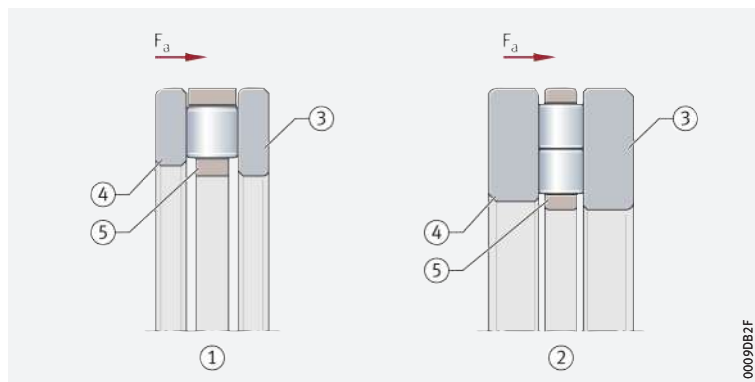

Roller profile and stress distribution

- ① Cylindrical roller profile (high stress peaks)
- ② Roller with profiled ends (no stress peak)
- ③ Cylindrical outside surface region
- ④ Region of logarithmic tapering
- ⑤ Rounding of edge

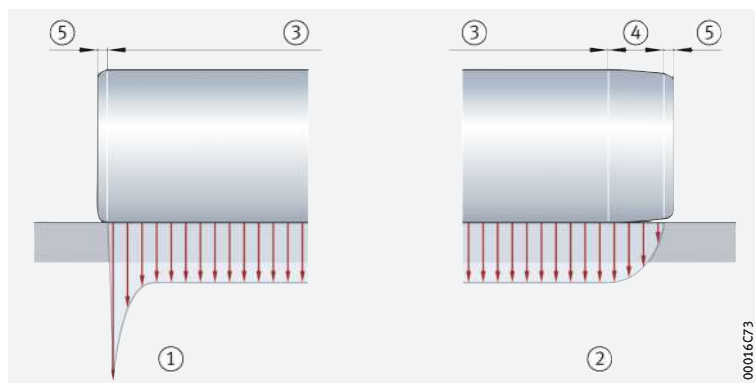

Axial cylindrical roller and cage assemblies

Very high axial load carrying capacity with low section height

For direct bearing arrangements, running surfaces must be produced as a rolling bearing raceway

The cage assemblies comprise axial cages and one or two rows of cylindrical rollers ▶ 1078 | 4. They have a particularly small axial section height and high axial load carrying capacity. The cages are made from polyamide or brass and are guided on the shaft.

Axial cylindrical roller and cage assemblies are generally combined with one housing locating washer and one shaft locating washer. If they are to be used directly – i.e. without axial bearing washers – in the adjacent construction, the raceway for the rollers must be produced as a rolling bearing raceway ▶ 1084 | 1.16. It is also possible to use two shaft locating washers or two housing locating washers in combination with one axial cylindrical roller and cage assembly.



The diameter series 1, 2, 3, 4 of the axial cylindrical roller and cage assemblies correspond to DIN 616:2000 and ISO 104:2015.



Axial cylindrical roller and cage assemblies

F_a = axial load

- ① Single row
- ② Double row

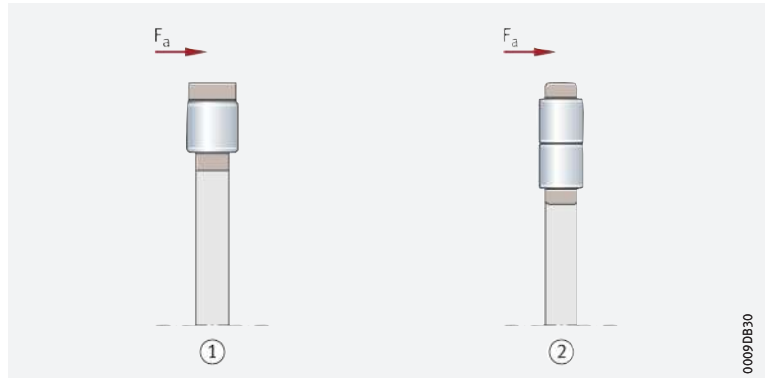

Axial bearing washers

Housing and shaft locating washers

Housing locating washers are externally centred, shaft locating washers are internally centred ▶ 1078 | 5 and ▶ 1084 | 1.16. They must be used if the adjacent construction cannot be used as a raceway for the rolling elements. The washers are made from through hardening rolling bearing steel. The bore and outside diameter are precision machined, the raceways are ground to high accuracy.



The diameter series 1, 2, 3, 4 of the axial bearing washers correspond to DIN 616:2000 and ISO 104:2015.

Bearing washers

Bearing washers are suitable for use as a housing or shaft locating washer. They are used in applications that do not require precise centring of the axial bearing washers. The raceway of the bearing washers is hardened and ground. The bearing washers are suitable for axial cylindrical roller and cage assemblies K811 and axial needle roller and cage assemblies AXK.



Axial bearing washers

- ① Housing locating washer, externally centred
- ② Shaft locating washer, internally centred
- ③ Bearing washer
- ④ Raceway

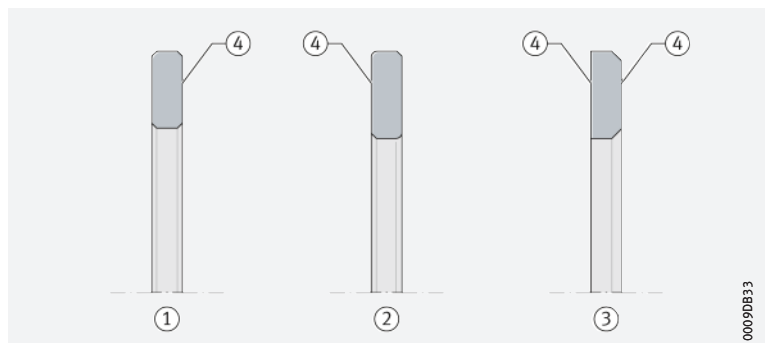

1.2 Load carrying capacity

☞ *For very high axial loads acting in one direction*

Single and double row axial cylindrical roller bearings can support high axial loads as well as axial shock loads in one direction, but must not be subjected to radial load ▶ 1083 | 1.14. If radial loads do occur, these forces must be supported by an additional bearing (e. g. by a needle roller and cage assembly) ▶ 1079 | 6.



6
Axial and radial loads

F_r = radial load

F_a = axial load

- ① Needle roller and cage assembly as radial bearing (direct bearing arrangement)
- ② Axial cylindrical roller and cage assembly as axial bearing (direct bearing arrangement)

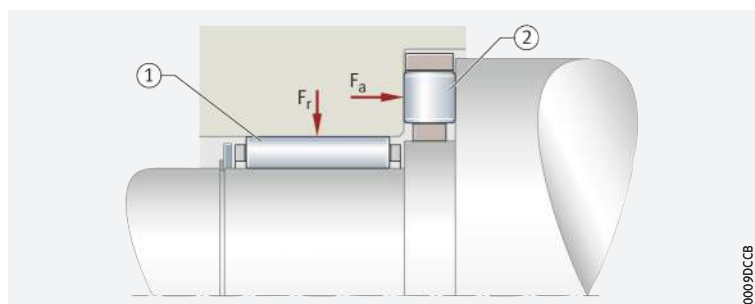

0009DCCB

1.3 Compensation of angular misalignments



The bearings do not permit any skewing between the shaft and the housing. If angular misalignments occur between the locating surfaces on the shaft and in the housing, this will cause damage to the bearing and considerably reduce its operating life.

1.4 Lubrication

☞ *Oil or grease lubrication is possible*

☞ *Compatibility with plastic cages*

Axial cylindrical roller bearings are not greased. The bearings must be lubricated with oil or grease.

When using bearings with plastic cages, compatibility between the lubricant and the cage material must be ensured if synthetic oils, lubricating greases with a synthetic oil base or lubricants containing a high proportion of EP additives are used.



If there is any uncertainty regarding the suitability of the selected lubricant for the application, please consult Schaeffler or the lubricant manufacturer.

☞ *Observe oil change intervals*

Aged oil and additives in the oil can impair the operating life of plastics at high temperatures. As a result, stipulated oil change intervals must be strictly observed.

1.5 Sealing



☞ *Provide seals in the adjacent construction*

The bearings are not sealed; i. e. sealing of the bearing position must be carried out in the adjacent construction. This must reliably prevent:

- moisture and contaminants from entering the bearing
- the egress of lubricant from the bearing position.

1.6 Speeds

 *Limiting speeds and reference speeds in the product tables*

Two speeds are generally indicated in the product tables  :

- the kinematic limiting speed n_G
- the thermal speed rating $n_{\vartheta r}$.

Limiting speed



The limiting speed n_G is the kinematically permissible speed of a bearing. Even under favourable mounting and operating conditions, this value should not be exceeded without prior consultation with Schaeffler  64. The values in the product tables are valid for oil lubrication.

 *Values for grease lubrication*

For grease lubrication, 25% of the value stated in the product tables is permissible in each case.

Reference speeds

 *$n_{\vartheta r}$ is used to calculate n_{ϑ}*

The thermal speed rating $n_{\vartheta r}$ is not an application-oriented speed limit, but is a calculated ancillary value for determining the thermally safe operating speed n_{ϑ}  64.

1.7 Noise

Schaeffler Noise Index

The Schaeffler Noise Index (SGI) is not yet available for this bearing type  69. The data for these bearing series will be introduced and updated in stages.

Further information:



■ **medias**  <https://medias.schaeffler.com>.

1.8 Temperature range

 *Limiting values*

The operating temperature of the bearings is limited by:

- the dimensional stability of the bearing washers and cylindrical rollers
- the cage
- the lubricant.

Possible operating temperatures of axial cylindrical roller bearings  1080  1.

 **1**
Permissible temperature range

Operating temperature	Axial cylindrical roller bearings with brass or polyamide cage PA66
	-20 °C to +120 °C



In the event of anticipated temperatures which lie outside the stated values, please contact Schaeffler.

1.9 Cages

☞ *Solid cages made from brass and polyamide PA66 are used as standard*

Standard cages ▶ 1081 | 2. The cage design is dependent on the bearing series and the bearing size. Other cage designs are available by agreement. With such cages, however, suitability for high speeds and temperatures as well as the basic load ratings may differ from the values for the bearings with standard cages.



For high continuous temperatures and applications with difficult operating conditions, bearings with brass cages should be used. If there is any uncertainty regarding cage suitability, please consult Schaeffler.



Cage, cage suffix, bore code

Bearing series	Solid cage made from polyamide PA66	Solid brass cage
	TV	M
	standard	standard
	Bore code	
811, K811	up to 34	from 36
812, K812	06 to 26	from 28
893, K893	06 to 16	17 to 30
894, K894	12 to 14	from 15



1.10 Internal clearance

☞ *Axial clearance and preload are determined by the application*

In the case of axial cylindrical roller bearings, the internal clearance (axial clearance) is only achieved when the bearings are mounted. The requisite axial clearance of the bearing arrangement is dependent on the application and must take account of the conditions in the bearing arrangement while warm from operation and subjected to load. If axial cylindrical roller bearings are subjected to vibrations while under predominantly static load, for example, they must be lightly preloaded. Preload can be applied, for example, using calibrated sheets (shims) ▶ 1081 | 7. Other suitable means include shaft nuts, disc springs, etc. ▶ 1084 | 1.15. It must always be ensured that no slippage occurs in operation between the rolling elements and raceways ▶ 1084 | 1.15. It must also be ensured that the preload does not exceed the optimum value, otherwise there will be an increase in friction and therefore in heat generation in the bearing. These will both have a negative effect on the operating life of the bearings.



If there is any uncertainty regarding correct setting, please consult Schaeffler.



Setting the axial clearance by means of shims

① Calibrated sheet (shim)

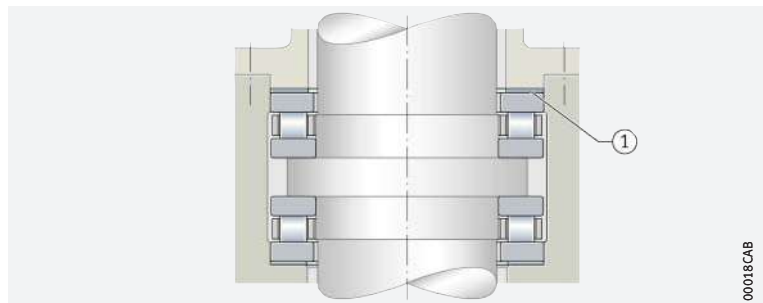

00018CAB

1.11 Dimensions, tolerances

Dimension standards



The main dimensions of axial cylindrical roller bearings correspond to ISO 104:2015.

Chamfer dimensions



The limiting dimensions for chamfer dimensions correspond to DIN 620-6:2004. Overview and limiting values > 138. Nominal value of chamfer dimension > 1088 | 3.

Tolerances



The dimensional and running tolerances of axial bearing washers GS and WS correspond to the tolerance class Normal in accordance with ISO 199:2014 > 133 | 25 to > 135 | 28.

Tolerances of the bore and outside diameter as well as of the width of the bearing parts > 1082 | 3 and > 1082 | 8.

3
Dimensions and tolerances of bearing parts

Bearing component	Dimension	Tolerance
Axial cylindrical roller and cage assembly K	D_{c1}	E11 ¹⁾
	D_c	a13 ¹⁾
	D_w	to DIN 5402-1
Housing locating washer GS	D_1	–
	D	to ISO 199
	B	h11
Shaft locating washer WS	d	to ISO 199
	d_1	–
	B	h11
Bearing washer LS	d	E12 ¹⁾
	D	a12 ¹⁾
	B	h11

¹⁾ Deviation of the bore diameter Δ_{dmp} and deviation of the outside diameter Δ_{Dmp} > 138.

8
Bearing parts – axial cylindrical roller and cage assemblies and bearing washers

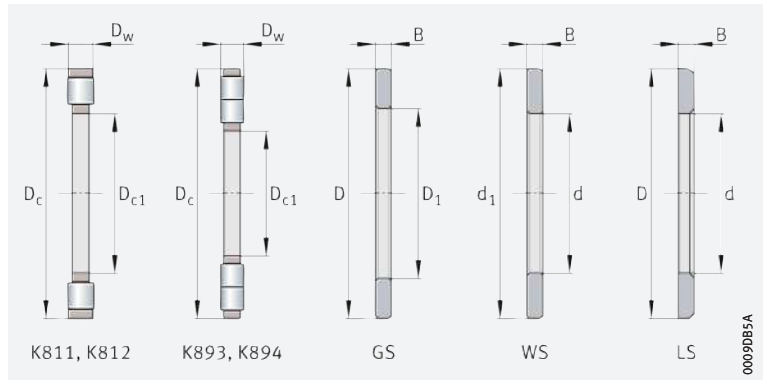

1.12 Suffixes

4
Suffixes and corresponding descriptions

For a description of the suffixes used in this chapter > 1082 | 4 and **medias** interchange > <https://www.schaeffler.de/std/1D52>.

Suffix	Description of suffix	
M	Solid brass cage	Standard, dependent on bore code
TV	Solid cage made from glass fibre reinforced polyamide PA66	
P5	High dimensional, geometrical and running accuracy	Special design for axial bearing washers GS, WS; available by agreement

1.13 Structure of bearing designation

Examples of composition of bearing designation

The designation of bearings follows a set model. Examples ▶ 1083| 9 and ▶ 1083| 10. The composition of the designation is subject to DIN 623-1 ▶ 102| 10.

9
Single row axial cylindrical roller bearing, comprising axial roller and cage assembly, shaft locating washer and housing locating washer: designation structure



10
Double row axial cylindrical roller bearing, comprising axial roller and cage assembly, shaft locating washer and housing locating washer: designation structure



1.14 Dimensioning

Equivalent dynamic bearing load



Axial cylindrical roller bearings can only support axial forces ▶ 1079| 1.2. In the rating life equation, P is therefore substituted by the value for F_a ▶ 1083| f1.

f1
Equivalent dynamic load

$$P = F_a$$

Legend

P	N	Equivalent dynamic bearing load
F_a	N	Axial load.

Equivalent static bearing load

Combined loads are not possible

In relation to the direction of load, the same conditions apply as for the equivalent dynamic bearing load, i. e. combined loads are not permissible. In the rating life equation, P_0 is therefore substituted by the value for F_{0a} ▶ 1083| f2.

f2
Equivalent static load

$$P_0 = F_{0a}$$

Legend

P_0	N	Equivalent static bearing load
F_{0a}	N	Largest axial load present (maximum load).

Static load safety factor

$S_0 = C_0/P_0$

In addition to the basic rating life $L(L_{10h})$, it is also always necessary to check the static load safety factor S_0 ▶ 1083| f3.

f3
Static load safety factor

$$S_0 = \frac{C_0}{P_0}$$

Legend

S_0	-	Static load safety factor
C_0	N	Basic static load rating
P_0	N	Equivalent static bearing load.

1.15 Minimum load

Rolling bearings under low loads are particularly prone to slippage

In order to prevent slippage damage, the bearing must be subjected to a minimum axial load $F_{a\ min}$ [▶1084](#) | [f1](#) 4 and [▶1084](#) | [5](#). In vertical bearing arrangements in particular, the requisite minimum axial load $F_{a\ min}$ is normally achieved, however, simply by the weight of the bearing parts and the external forces. If this is not the case, the bearing arrangement must be preloaded, for example by means of springs or a housing nut.

[f1](#) 4
Minimum axial load

$$F_{a\ min} = 0,0005 \cdot C_{0a} + k_a \left(\frac{C_{0a} \cdot n}{10^8} \right)^2$$

Legend

$F_{a\ min}$	N	Minimum axial load
C_{0a}	N	Basic static load rating ▶1088 5
k_a	-	Factor for determining the minimum axial load ▶1084 5
n	min ⁻¹	Speed.

[5](#)
Factor k_a for calculating the minimum axial load

Series	Factor k_a
K811	1,4
K812	0,9
K893	0,7
K894	0,5

1.16 Design of bearing arrangements

Design of adjacent parts



Axial cylindrical roller bearings cannot tolerate angular misalignments [▶1079](#) | 1.3. The locating surfaces for the bearing parts on the shaft and in the housing must therefore be vertical to the shaft axis, while the adjacent parts must be rigid and flat. They must be configured such that the bearing washers are supported as far as possible over the whole circumference and over the whole raceway width; values [▶1088](#) | [5](#). The radial cage guidance surfaces must be precision machined and wear-resistant (Ramax 0,8 (Rzmax 4)).

Mounting diameter on the shaft and in the housing

For the mounting dimensions, the following values apply [▶1088](#) | [5](#):

- mounting diameter on the shaft $\geq d_a$
- mounting diameter in the housing $\leq D_a$.

Tolerances for shaft and housing bore

Proven tolerances are given in [▶1084](#) | [6](#). If the data are observed, this will give correct radial guidance of the bearing elements.

[6](#)
Tolerances for shafts and housing bores

Bearing component		Tolerance class ¹⁾ for	
		Shaft	Bore
Axial cylindrical roller bearings	Shaft guided	h8	-
Housing locating washers	-	-	H9
Shaft locating washers	-	h8	-
Bearing washers	Externally centred as housing locating washer	Shaft released	H9
	Internally centred as shaft locating washer	h8	Bore released

¹⁾ The envelope requirement [©](#) applies.

☞ *Release of shaft and housing locating washers, as a function of centring*

Guidance of bearing parts

If the bearing washers are centred on the shaft, they must have radial clearance in the housing bore while, if they are centred in the housing, there must be radial clearance between the washer bore and the shaft
 ► 1085 | ☞ 11.

☞ 11

Guidance and release of shaft and housing locating washers

- ① Housing locating washer (guidance in the housing), radial clearance on the shaft
- ② Shaft locating washer (guidance on the shaft), radial clearance in the housing

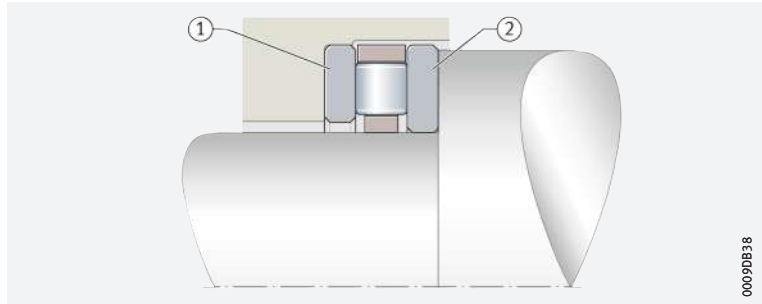

☞ *Guidance of axial roller and cage assemblies*

In order to achieve the lowest possible sliding speeds on the guidance surfaces, the axial cylindrical roller and cage assemblies are generally guided on the shaft. This is particularly important in the case of high speeds.

☞ *For a direct bearing arrangement of roller and cage assemblies: harden and grind the raceways for the rollers*

If the axial design space is particularly small, axial cylindrical roller and cage assemblies can also run directly (without axial bearing washers) on the adjacent construction. In this case – and if the load carrying capacity of the axial cylindrical roller and cage assemblies is to be fully utilised – the raceways on the shaft and in the housing must be produced as a rolling bearing raceway or must correspond to the quality and hardness of axial bearing washers. The surface hardness of the raceway must be 670 HV to 840 HV, the hardening depth CHD or SHD must be sufficiently large ► 180. The surface roughness Ra must be $\leq 0,2 \mu\text{m}$. At a mean roughness value of $Ra > 0,2 \mu\text{m}$, it is no longer possible to utilise the full load carrying capacity of the bearings. When designing the raceway on the shaft and in the housing, the raceway dimensions E_a and E_b must be observed ► 1088 | ☞. If the values are observed, this will ensure that the raceways for the cylindrical rollers – taking account of any possible axial offset of the roller and cage assembly – are adequately dimensioned.

1.17

Mounting and dismounting



The mounting and dismounting options for the bearings must be taken into consideration in the design of the bearing position.

☞ *As the bearings are not self-retaining, they are easy to mount*

Axial cylindrical roller bearings are not self-retaining. As a result, the bearing parts (shaft locating washer, housing locating washer and axial cylindrical roller and cage assembly) can be mounted separately from each other. This gives simplified mounting of the bearings.

Mounting position of the bearing washers

The correct mounting position has a considerable influence on the function of the bearing arrangement. Axial bearing washers must always be mounted with the raceway side facing the rolling elements.

☞ *Shaft locating washers*

On shaft locating washers, the raceway side is indicated by the smaller chamfer on the bore diameter of the washer.

☞ *Housing locating washers*

On housing locating washers, the raceway side is indicated by the smaller chamfer on the outside diameter of the washer.

📖 *Rolling bearings must be handled with great care*

Schaeffler Mounting Handbook

Rolling bearings are well-proven precision machine elements for the design of economical and reliable bearing arrangements, which offer high operational security. In order that these products can function correctly and achieve the envisaged operating life without detrimental effect, they must be handled with care.



The Schaeffler Mounting Handbook MH 1 gives comprehensive information about the correct storage, mounting, dismounting and maintenance of rotary rolling bearings ► <https://www.schaeffler.de/std/1D53>. It also provides information which should be observed by the designer, in relation to the mounting, dismounting and maintenance of bearings, in the original design of the bearing position. This book is available from Schaeffler on request.

1.18 Legal notice regarding data freshness

📖 *The further development of products may also result in technical changes to catalogue products*

Of central interest to Schaeffler is the further development and optimisation of its products and the satisfaction of its customers. In order that you, as the customer, can keep yourself optimally informed about the progress that is being made here and with regard to the current technical status of the products, we publish any product changes which differ from the printed version in our electronic product catalogue.



We therefore reserve the right to make changes to the data and illustrations in this catalogue. This catalogue reflects the status at the time of printing. More recent publications released by us (as printed or digital media) will automatically precede this catalogue if they involve the same subject. Therefore, please always use our electronic product catalogue to check whether more up-to-date information or modification notices exist for your desired product.

Link to electronic product catalogue



The following link will take you to the Schaeffler electronic product catalogue: ► <https://medias.schaeffler.com>.

1.19 Further information



In addition to the data in this chapter, the following chapters in Technical principles must also be observed in the design of bearing arrangements:

- Determining the bearing size ► 34
- Rigidity ► 54
- Friction and increases in temperature ► 56
- Speeds ► 64
- Bearing data ► 97
- Lubrication ► 70
- Sealing ► 182
- Design of bearing arrangements ► 139
- Mounting and dismounting ► 191.





Axial cylindrical roller bearings

Axial cylindrical roller and cage assemblies
Axial bearing washers

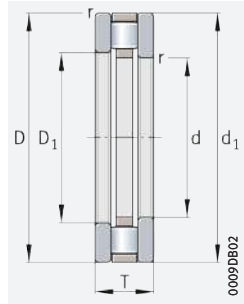

811, 812

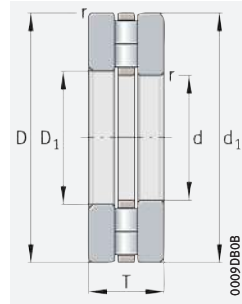

893, 894

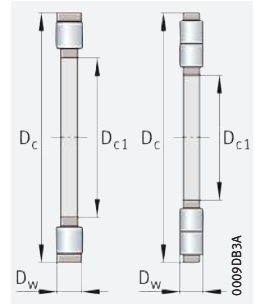

Single row: K811, K812
Double row: K893, K894

d = 15 – 60 mm

Main dimensions			Basic load ratings		Fatigue limit load	Limiting speed	Speed rating	Axial cylindrical roller bearings		Axial cylindrical roller and cage assemblies	
								Mass	Designation	Mass	Designation
d	D _{c1}	T	dyn. C _a	stat. C _{0a}	C _{ua}	n _G	n _{gr}	m		m	
			N	N	N	min ⁻¹	min ⁻¹	≈ kg		≈ kg	
15	28	9	14 400	28 500	4 000	13 600	6 400	0,024	81102-TV	0,006	K81102-TV
17	30	9	16 000	33 500	4 650	12 800	5 800	0,027	81103-TV	0,009	K81103-TV
20	35	10	25 000	53 000	7 300	10 800	4 500	0,037	81104-TV	0,013	K81104-TV
25	42	11	33 500	76 000	7 100	8 900	3 650	0,053	81105-TV	0,015	K81105-TV
30	47	11	35 500	86 000	8 000	7 700	3 150	0,057	81106-TV	0,017	K81106-TV
	52	16	64 000	141 000	14 100	7 200	2 700	0,123	81206-TV	0,033	K81206-TV
	60	18	69 000	197 000	18 900	6 400	2 650	0,24	89306-TV	0,04	K89306-TV
35	52	12	39 000	101 000	9 500	6 800	2 700	0,073	81107-TV	0,019	K81107-TV
	62	18	80 000	199 000	20 000	6 000	2 360	0,195	81207-TV	0,043	K81207-TV
	68	20	80 000	237 000	23 200	5 700	2 420	0,34	89307-TV	0,053	K89307-TV
40	60	13	56 000	148 000	14 500	5 900	2 240	0,105	81108-TV	0,031	K81108-TV
	68	19	107 000	265 000	23 300	5 200	1 820	0,249	81208-TV	0,081	K81208-TV
	78	22	123 000	385 000	39 000	4 850	1 770	0,484	89308-TV	0,098	K89308-TV
45	65	14	59 000	163 000	16 000	5 300	2 020	0,13	81109-TV	0,035	K81109-TV
	73	20	105 000	265 000	23 300	4 950	1 840	0,287	81209-TV	0,085	K81209-TV
	85	24	139 000	445 000	44 500	4 400	1 600	0,615	89309-TV	0,121	K89309-TV
50	70	14	62 000	177 000	17 400	4 900	1 840	0,14	81110-TV	0,038	K81110-TV
	78	22	118 000	315 000	27 500	4 550	1 570	0,356	81210-TV	0,098	K81210-TV
	95	27	168 000	560 000	58 000	3 950	1 450	0,887	89310-TV	0,175	K89310-TV
55	78	16	90 000	300 000	31 000	4 350	1 350	0,218	81111-TV	0,045	K81111-TV
	90	25	155 000	405 000	38 500	4 050	1 540	0,568	81211-TV	0,166	K81211-TV
	105	30	184 000	600 000	52 000	3 600	1 500	1,18	89311-TV	0,195	K89311-TV
60	85	17	103 000	315 000	32 000	4 000	1 360	0,266	81112-TV	0,082	K81112-TV
	95	26	172 000	480 000	45 500	3 700	1 290	0,642	81212-TV	0,176	K81212-TV
	110	30	197 000	670 000	58 000	3 400	1 350	1,26	89312-TV	0,21	K89312-TV
	130	42	390 000	1 220 000	129 000	3 050	1 080	2,818	89412-TV	0,538	K89412-TV

medias ► <https://www.schaeffler.de/std/1DCC>

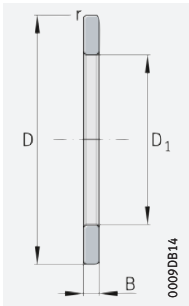

GS

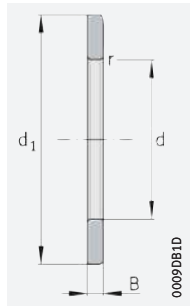

WS

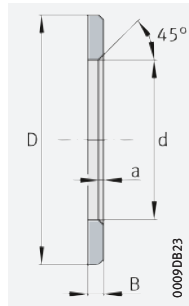

LS

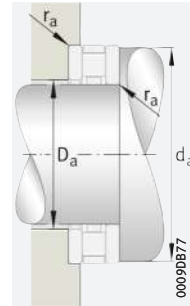

Mounting dimensions

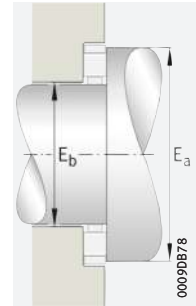

Mounting dimensions, direct bearing arrangement



d D _{c1}	Axial bearing washers				Dimensions					Mounting dimensions			Raceway dimensions	
	Mass m ≈ kg	Designation ▶ 1082 1.12 ▶ 1083 1.13			D ₁	d ₁	D _w	B	a r min.	d _a	D _a	r _a	E _b	E _a
		Housing locating washer	Shaft locating washer	Bearing washer										
15	0,008	GS81102	WS81102	LS1528	16	28	3,5	2,75	0,3	27	16	0,3	16	27
17	0,009	GS81103	WS81103	LS1730	18	30	3,5	2,75	0,3	29	18	0,3	18	29
20	0,011	GS81104	WS81104	LS2035	21	35	4,5	2,75	0,3	34	21	0,3	21	34
25	0,019	GS81105	WS81105	LS2542	26	42	5	3	0,6	41	26	0,6	26	41
30	0,02	GS81106	WS81106	LS3047	32	47	5	3	0,6	46	31	0,6	31	46
	0,045	GS81206	WS81206	–	32	52	7,5	4,25	0,6	50	31	0,6	31	50
	0,095	GS89306	WS89306	–	32	60	5,5	6,25	1	59	33	1	33	59
35	0,027	GS81107	WS81107	LS3552	37	52	5	3,5	0,6	51	36	0,6	36	51
	0,076	GS81207	WS81207	–	37	62	7,5	5,25	1	58	39	1	39	58
	0,134	GS89307	WS89307	–	37	68	6	7	1	67	38	1	38	67
40	0,037	GS81108	WS81108	LS4060	42	60	6	3,5	0,6	58	42	0,6	42	58
	0,084	GS81208	WS81208	–	42	68	9	5	1	66	43	1	43	66
	0,193	GS89308	WS89308	–	42	78	7	7,5	1	77	44	1	44	77
45	0,047	GS81109	WS81109	LS4565	47	65	6	4	0,6	63	47	0,6	47	63
	0,101	GS81209	WS81209	–	47	73	9	5,5	1	70	48	1	48	70
	0,247	GS89309	WS89309	–	47	85	7,5	8,25	1	83	49	1	49	83
50	0,051	GS81110	WS81110	LS5070	52	70	6	4	0,6	68	52	0,6	52	68
	0,129	GS81210	WS81210	–	52	78	9	6,5	1	75	53	1	53	75
	0,356	GS89310	WS89310	–	52	95	8	9,5	1,1	92	56	1,1	56	92
55	0,082	GS81111	WS81111	LS5578	57	78	6	5	0,6	77	56	0,6	57	77
	0,201	GS81211	WS81211	–	57	90	11	7	1	85	59	1	59	85
	0,485	GS89311	WS89311	–	57	105	9	10,5	1,1	103	61	1,1	61	103
60	0,092	GS81112	WS81112	LS6085	62	85	7,5	4,75	1	82	62	1	62	82
	0,233	GS81212	WS81212	–	62	95	11	7,5	1	91	64	1	64	91
	0,55	GS89312	WS89312	–	62	110	9	10,5	1,1	108	66	1,1	66	108
	1,115	GS89412	WS89412	–	62	130	14	14	1,5	126	65	1,5	65	126



Axial cylindrical roller bearings

Axial cylindrical roller and cage assemblies
Axial bearing washers

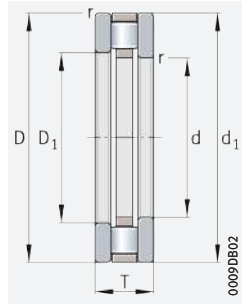

811, 812

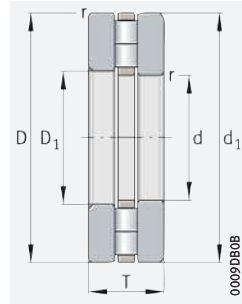

893, 894

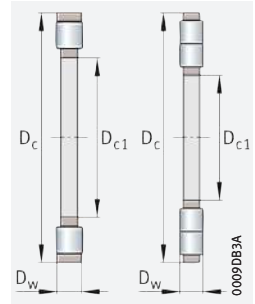

Single row: K811, K812
Double row: K893, K894

d = 65 – 100 mm

Main dimensions			Basic load ratings		Fatigue limit load	Limiting speed	Speed rating	Axial cylindrical roller bearings		Axial cylindrical roller and cage assemblies	
								Mass	Designation	Mass	Designation
d	D	T	dyn. C _a	stat. C _{0a}	C _{ua}	n _G	n _{thr}	m		m	
D _{c1}	D _c		N	N	N	min ⁻¹	min ⁻¹	≈ kg		≈ kg	
65	90	18	107 000	340 000	34 000	3 700	1 260	0,31	81113-TV	0,09	K81113-TV
	100	27	177 000	500 000	48 000	3 550	1 250	0,721	81213-TV	0,185	K81213-TV
	115	30	194 000	670 000	58 000	3 200	1 330	1,33	89313-TV	0,21	K89313-TV
	140	45	445 000	1 410 000	148 000	2 850	1 010	3,52	89413-TV	0,72	K89413-TV
70	95	18	111 000	365 000	36 500	3 500	1 170	0,332	81114-TV	0,092	K81114-TV
	105	27	187 000	550 000	53 000	3 250	1 120	0,768	81214-TV	0,212	K81214-TV
	125	34	239 000	830 000	75 000	2 950	1 200	1,82	89314-TV	0,29	K89314-TV
	150	48	475 000	1 500 000	158 000	2 650	1 010	4,18	89414-TV	0,76	K89414-TV
75	100	19	107 000	350 000	35 500	3 300	1 190	0,393	81115-TV	0,096	K81115-TV
	110	27	173 000	500 000	48 000	3 150	1 220	0,8	81215-TV	0,195	K81215-TV
	135	36	290 000	1 010 000	92 000	2 750	1 090	2,23	89315-TV	0,375	K89315-TV
	160	51	500 000	1 580 000	160 000	2 440	1 000	5,96	89415-M	1,78	K89415-M
80	105	19	106 000	350 000	35 500	3 150	1 180	0,4	81116-TV	0,095	K81116-TV
	115	28	201 000	630 000	60 000	2 900	980	0,9	81216-TV	0,234	K81216-TV
	140	36	305 000	1 110 000	100 000	2 650	1 000	2,37	89316-TV	0,42	K89316-TV
	170	54	560 000	1 770 000	180 000	2 280	940	7,04	89416-M	2,04	K89416-M
85	110	19	113 000	385 000	39 000	3 000	1 090	0,42	81117-TV	0,118	K81117-TV
	125	31	217 000	660 000	65 000	2 800	1 080	1,26	81217-TV	0,28	K81217-TV
	150	39	325 000	1 140 000	104 000	2 450	1 030	3,39	89317-M	0,93	K89317-M
	180	58	620 000	1 980 000	199 000	2 160	890	8,65	89417-M	2,71	K89417-M
90	120	22	141 000	465 000	40 000	2 750	1 070	0,62	81118-TV	0,15	K81118-TV
	135	35	290 000	890 000	94 000	2 550	910	1,77	81218-TV	0,54	K81218-TV
	155	39	335 000	1 200 000	109 000	2 350	980	3,63	89318-M	0,97	K89318-M
	190	60	680 000	2 200 000	221 000	2 040	840	9,94	89418-M	3,04	K89418-M
100	135	25	199 000	650 000	60 000	2 480	930	0,95	81120-TV	0,25	K81120-TV
	150	38	340 000	1 080 000	111 000	2 300	840	2,2	81220-TV	0,6	K81220-TV
	170	42	380 000	1 400 000	123 000	2 130	910	4,56	89320-M	1,18	K89320-M
	210	67	850 000	2 850 000	280 000	1 830	710	13,42	89420-M	3,92	K89420-M

medias ► <https://www.schaeffler.de/std/1DCD>

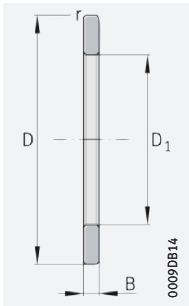

GS

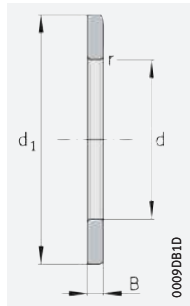

WS

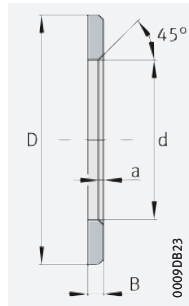

LS

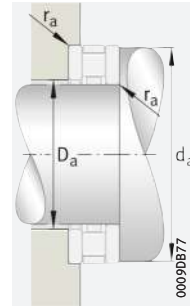

Mounting dimensions

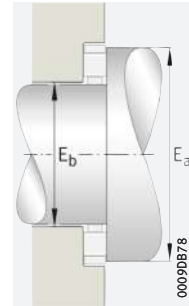

Mounting dimensions, direct bearing arrangement



d D _{c1}	Axial bearing washers				Dimensions					Mounting dimensions			Raceway dimensions	
	Mass m ≈ kg	Designation ▶ 1082 1.12 ▶ 1083 1.13			D ₁	d ₁	D _w	B	a r min.	d _a	D _a	r _a	E _b	E _a
		Housing locating washer	Shaft locating washer	Bearing washer										
65	0,11	GS81113	WS81113	LS6590	67	90	7,5	5,25	1	87	67	1	67	87
	0,268	GS81213	WS81213	–	67	100	11	8	1	96	69	1	69	96
	0,535	GS89313	WS89313	–	67	115	9	10,5	1,1	113	71	1,1	71	113
	1,4	GS89413	WS89413	–	68	140	15	15	2	135	70	2	70	135
70	0,12	GS81114	WS81114	LS7095	72	95	7,5	5,25	1	92	72	1	72	92
	0,278	GS81214	WS81214	–	72	105	11	8	1	102	74	1	74	102
	0,8	GS89314	WS89314	–	72	125	10	12	1,1	123	76	1,1	76	123
	1,73	GS89414	WS89414	–	73	150	16	16	2	147	76	2	76	147
75	0,136	GS81115	WS81115	LS75100	77	100	7,5	5,75	1	97	78	1	78	97
	0,293	GS81215	WS81215	–	77	110	11	8	1	106	79	1	79	106
	0,97	GS89315	WS89315	–	77	135	11	12,5	1,5	132	81	1,5	81	132
	2,09	GS89415	WS89415	–	78	160	17	17	2	156	82	2	82	156
80	0,144	GS81116	WS81116	LS80105	82	105	7,5	5,75	1	102	83	1	83	102
	0,333	GS81216	WS81216	–	82	115	11	8,5	1	112	84	1	84	112
	1,02	GS89316	WS89316	–	82	140	11	12,5	1,5	137	86	1,5	86	137
	2,5	GS89416	WS89416	–	83	170	18	18	2,1	165	88	2,1	88	165
85	0,151	GS81117	WS81117	LS85110	87	110	7,5	5,75	1	108	87	1	87	108
	0,49	GS81217	WS81217	–	88	125	12	9,5	1	119	90	1	90	119
	1,23	GS89317	WS89317	–	88	150	12	13,5	1,5	147	93	1,5	93	146
	2,97	GS89417	WS89417	–	88	180	19	19,5	2,1	175	93	2,1	93	175
90	0,225	GS81118	WS81118	LS90120	92	120	9	6,5	1	117	93	1	93	117
	0,614	GS81218	WS81218	–	93	135	14	10,5	1,1	129	95	1,1	95	129
	1,33	GS89318	WS89318	–	93	155	12	13,5	1,5	152	98	1,5	98	151
	3,45	GS89418	WS89418	–	93	190	20	20	2,1	185	99	2,1	99	185
100	0,35	GS81120	WS81120	LS100135	102	135	11	7	1	131	104	1	104	131
	0,8	GS81220	WS81220	–	103	150	15	11,5	1,1	142	107	1,1	107	142
	1,69	GS89320	WS89320	–	103	170	13	14,5	1,5	167	107	1,5	109	166
	4,75	GS89420	WS89420	–	103	210	22	22,5	3	205	111	3	111	205



Axial cylindrical roller bearings

Axial cylindrical roller and cage assemblies
Axial bearing washers

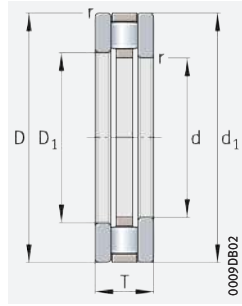

811, 812

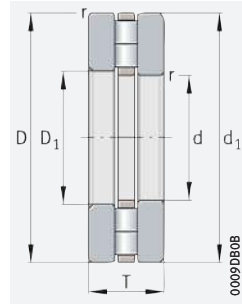

893, 894

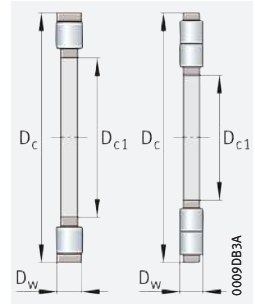

Single row: K811, K812
Double row: K893, K894

d = 110 – 170 mm

Main dimensions			Basic load ratings		Fatigue limit load	Limiting speed	Speed rating	Axial cylindrical roller bearings		Axial cylindrical roller and cage assemblies	
								Mass	Designation	Mass	Designation
d	D _{c1}	T	dyn. C _a	stat. C _{0a}	C _{ua}	n _G	n _{dr}	m		m	
			N	N	N	min ⁻¹	min ⁻¹	≈ kg		≈ kg	
110	145	25	207 000	700 000	63 000	2 280	860	1,04	81122-TV	0,27	K81122-TV
	160	38	325 000	1 030 000	104 000	2 150	870	2,29	81222-TV	0,53	K81222-TV
	190	48	500 000	1 870 000	177 000	1 900	780	6,7	89322-M	1,83	K89322-M
	230	73	1 010 000	3 400 000	330 000	1 680	640	17,41	89422-M	5,11	K89422-M
120	155	25	214 000	760 000	66 000	2 110	790	1,12	81124-TV	0,29	K81124-TV
	170	39	340 000	1 120 000	111 000	2 000	800	2,54	81224-TV	0,58	K81224-TV
	210	54	640 000	2 420 000	224 000	1 730	690	9,44	89324-M	2,64	K89324-M
	250	78	1 170 000	4 000 000	385 000	1 540	570	21,9	89424-M	6,37	K89424-M
130	170	30	255 000	900 000	79 000	1 940	770	1,67	81126-TV	0,38	K81126-TV
	190	45	480 000	1 520 000	151 000	1 820	720	3,98	81226-TV	0,92	K81226-TV
	225	58	720 000	2 700 000	250 000	1 620	650	11,2	89326-M	2,09	K89326-M
	270	85	1 330 000	4 600 000	430 000	1 420	520	27,1	89426-M	7,96	K89426-M
140	180	31	260 000	960 000	83 000	1 820	720	1,9	81128-TV	0,4	K81128-TV
	200	46	455 000	1 450 000	141 000	1 690	730	5,07	81228-M	1,8	K81228-M
	240	60	820 000	3 200 000	290 000	1 520	570	13,2	89328-M	2,57	K89328-M
	280	85	1 390 000	4 950 000	455 000	1 350	480	29,8	89428-M	8,53	K89428-M
150	190	31	270 000	1 020 000	86 000	1 710	670	2,2	81130-TV	0,43	K81130-TV
	215	50	590 000	1 940 000	188 000	1 580	610	7,17	81230-M	2,81	K81230-M
	250	60	840 000	3 350 000	300 000	1 440	540	13,9	89330-M	3,75	K89330-M
	300	90	1 580 000	5 700 000	520 000	1 250	440	35,4	89430-M	10,4	K89430-M
160	200	31	270 000	1 050 000	87 000	1 610	640	2,12	81132-TV	0,44	K81132-TV
	225	51	600 000	2 030 000	194 000	1 500	580	7,6	81232-M	3,01	K81232-M
	320	95	1 780 000	6 500 000	590 000	1 170	400	42	89432-M	12,4	K89432-M
170	215	34	360 000	1 380 000	124 000	1 510	570	2,41	81134-TV	0,66	K81134-TV
	240	55	680 000	2 340 000	222 000	1 400	540	9,3	81234-M	3,5	K81234-M
	340	103	1 990 000	7 400 000	660 000	1 100	365	51,9	89434-M	14,9	K89434-M

medias ► <https://www.schaeffler.de/std/1DCE>

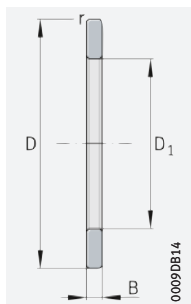

GS

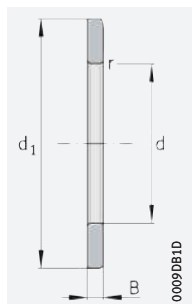

WS

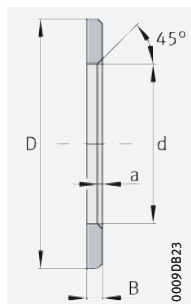

LS

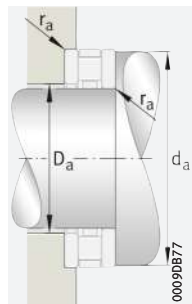

Mounting dimensions

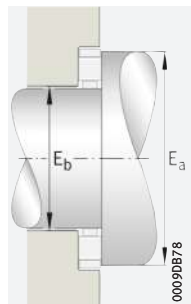

Mounting dimensions, direct bearing arrangement



d D _{c1}	Axial bearing washers				Dimensions					Mounting dimensions			Raceway dimensions	
	Mass m ≈ kg	Designation ▶ 1082 1.12 ▶ 1083 1.13			D ₁	d ₁	D _w	B	a r min.	d _a	D _a	r _a	E _b	E _a
		Housing locating washer	Shaft locating washer	Bearing washer										
110	0,385	GS81122	WS81122	LS110145	112	145	11	7	1	141	114	1	114	141
	0,88	GS81222	WS81222	–	113	160	15	11,5	1,1	152	117	1,1	117	152
	2,44	GS89322	WS89322	–	113	190	15	16,5	2	186	120	2	120	185
	6,15	GS89422	WS89422	–	113	230	24	24,5	3	223	121	3	121	223
120	0,415	GS81124	WS81124	LS120155	122	155	11	7	1	151	124	1	124	151
	0,98	GS81224	WS81224	–	123	170	15	12	1,1	162	127	1,1	127	162
	3,4	GS89324	WS89324	–	123	210	17	18,5	2,1	206	130	2,1	132	205
	7,7	GS89424	WS89424	–	123	250	26	26	4	243	133	4	133	243
130	0,643	GS81126	WS81126	LS130170	132	170	12	9	1	165	135	1	135	165
	1,53	GS81226	WS81226	–	133	187	19	13	1,5	181	137	1,5	137	181
	4,045	GS89326	WS89326	–	134	225	18	20	2,1	220	141	2,1	141	219
	9,5	GS89426	WS89426	–	134	270	28	28,5	4	263	145	4	145	263
140	0,749	GS81128	WS81128	LS140180	142	178	12	9,5	1	175	145	1	145	175
	1,635	GS81228	WS81228	–	143	197	19	13,5	1,5	191	147	1,5	151	195
	4,8	GS89328	WS89328	–	144	240	19	20,5	2,1	235	152	2,1	152	234
	10,6	GS89428	WS89428	–	144	280	28	28,5	4	273	155	4	155	273
150	0,796	GS81130	WS81130	LS150190	152	188	12	9,5	1	185	155	1	155	185
	2,18	GS81230	WS81230	–	153	212	21	14,5	1,5	211	158	1,5	162	210
	5,06	GS89330	WS89330	–	154	250	19	20,5	2,1	245	162	2,1	162	244
	12,5	GS89430	WS89430	–	154	300	30	30	4	293	167	4	167	293
160	0,842	GS81132	WS81132	LS160200	162	198	12	9,5	1	195	165	1	165	195
	2,3	GS81232	WS81232	–	163	222	21	15	1,5	220	168	1,5	171	219
	14,8	GS89432	WS89432	–	164	320	32	31,5	5	313	179	5	179	313
170	1,1	GS81134	WS81134	–	172	213	14	10	1,1	209	176	1,1	176	209
	2,9	GS81234	WS81234	–	173	237	22	16,5	1,5	235	180	1,5	184	233
	18,5	GS89434	WS89434	–	174	340	34	34,5	5	333	191	5	191	333



Axial cylindrical roller bearings

Axial cylindrical roller and cage assemblies
Axial bearing washers

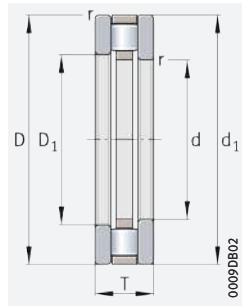

811, 812

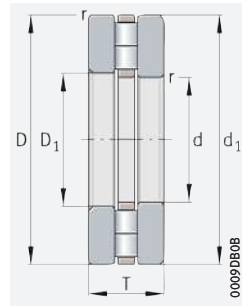

893, 894

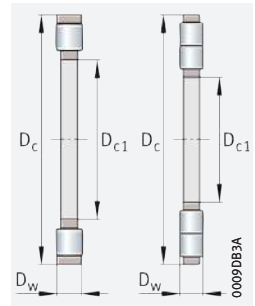

Single row: K811, K812
Double row: K893, K894

d = 180 – 320 mm

Main dimensions			Basic load ratings		Fatigue limit load	Limiting speed	Speed rating	Axial cylindrical roller bearings		Axial cylindrical roller and cage assemblies	
								Mass	Designation	Mass	Designation
d	D _{c1}	T	dyn. C _a	stat. C _{0a}	C _{ua}	n _G	n _{thr}	m		m	
			N	N	N	min ⁻¹	min ⁻¹	≈ kg		≈ kg	
180	225	34	340 000	1 300 000	115 000	1 430	590	3,3	81136-M	1,46	K81136-M
	250	56	700 000	2 440 000	228 000	1 340	520	9,9	81236-M	3,67	K81236-M
	360	109	2 210 000	8 200 000	720 000	1 050	345	60	89436-M	17,6	K89436-M
190	240	37	390 000	1 500 000	131 000	1 340	570	4,74	81138-M	1,84	K81138-M
	270	62	880 000	3 000 000	285 000	1 250	475	12,8	81238-M	5,17	K81238-M
	380	115	2 460 000	9 200 000	800 000	1 010	330	72,1	89438-M	20,9	K89438-M
200	250	37	395 000	1 550 000	134 000	1 290	550	4,95	81140-M	1,93	K81140-M
	280	62	900 000	3 150 000	295 000	1 190	450	14,2	81240-M	5,4	K81240-M
	400	122	2 700 000	10 200 000	880 000	960	305	82,6	89440-M	24	K89440-M
220	270	37	420 000	1 730 000	146 000	1 180	490	5,22	81144-M	2,04	K81144-M
	300	63	950 000	3 450 000	310 000	1 100	405	15,3	81244-M	5,8	K81244-M
	420	122	2 900 000	11 500 000	980 000	880	265	90,1	89444-M	25,7	K89444-M
240	300	45	600 000	2 500 000	212 000	1 070	420	8,45	81148-M	3,32	K81148-M
	340	78	1 370 000	5 000 000	445 000	970	330	26,2	81248-M	9,94	K81248-M
	440	122	3 000 000	12 200 000	1 030 000	850	250	95,9	89448-M	27,3	K89448-M
260	320	45	620 000	2 650 000	219 000	990	390	9,08	81152-M	3,55	K81152-M
	360	79	1 440 000	5 400 000	475 000	910	305	28,6	81252-M	10,8	K81252-M
	480	132	3 600 000	14 700 000	1 200 000	780	224	125	89452-M	36,8	K89452-M
280	350	53	870 000	3 650 000	305 000	910	330	12,6	81156-M	5,31	K81156-M
	380	80	1 460 000	5 600 000	485 000	860	290	31	81256-M	11,5	K81256-M
	520	145	4 250 000	17 600 000	1 420 000	700	195	159	89456-M	48,5	K89456-M
300	380	62	1 070 000	4 500 000	370 000	840	295	19,4	81160-M	7,6	K81160-M
	420	95	1 930 000	7 300 000	620 000	780	255	48,25	81260-M	17,8	K81260-M
	540	145	4 350 000	18 500 000	1 480 000	670	184	170	89460-M	49,8	K89460-M
320	400	63	1 100 000	4 750 000	385 000	800	280	20,7	81164-M	8,04	K81164-M
	580	155	5 500 000	19 900 000	1 460 000	640	184	203	89464-M	80,3	K89464-M

medias ► <https://www.schaeffler.de/std/1DCF>

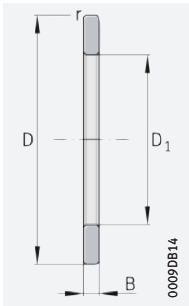

GS

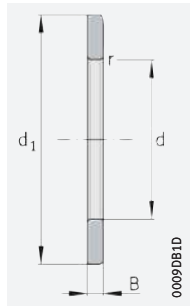

WS

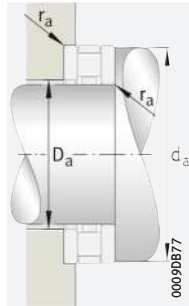

Mounting dimensions

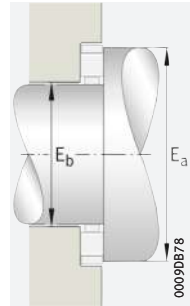

Mounting dimensions, direct bearing arrangement



d D _{c1}	Axial bearing washers			Dimensions					Mounting dimensions			Raceway dimensions	
	m ≈ kg	Designation ▶ 1082 1.12 ▶ 1083 1.13		D ₁	d ₁	D _w	B	a r min.	d _a	D _a	r _a	E _b	E _a
		Housing locating washer	Shaft locating washer										
180	1,12	GS81136	WS81136	183	222	14	10	1,1	219	185	1,1	186	220
	3,13	GS81236	WS81236	183	247	22	17	1,5	245	190	1,5	194	243
	21,3	GS89436	WS89436	184	360	36	36,5	5	351	200	5	200	351
190	1,45	GS81138	WS81138	193	237	15	11	1,1	233	197	1,1	198	234
	3,835	GS81238	WS81238	194	267	26	18	2	265	200	2	205	263
	25,6	GS89438	WS89438	195	380	38	38,5	5	373	214	5	212	371
200	1,51	GS81140	WS81140	203	247	15	11	1,1	243	206	1,1	208	244
	4,41	GS81240	WS81240	204	277	26	18	2	275	210	2	215	273
	29,3	GS89440	WS89440	205	400	40	41	5	393	226	5	224	391
220	1,59	GS81144	WS81144	223	267	15	11	1,1	263	226	1,1	228	264
	4,75	GS81244	WS81244	224	297	26	18,5	2	296	230	2	236	294
	32,2	GS89444	WS89444	225	420	40	41	6	411	244	6	244	411
240	2,57	GS81148	WS81148	243	297	18	13,5	1,5	296	248	1,5	253	294
	8,15	GS81248	WS81248	244	335	32	23	2,1	335	261	2,1	263	333
	34,3	GS89448	WS89448	245	440	40	41	6	433	266	6	264	431
260	2,765	GS81152	WS81152	263	317	18	13,5	1,5	316	268	1,5	272	314
	8,9	GS81252	WS81252	264	355	32	23,5	2,1	353	280	2,1	281	351
	44,25	GS89452	WS89452	265	480	44	44	6	472	288	6	286	468
280	3,65	GS81156	WS81156	283	347	22	15,5	1,5	346	288	1,5	294	344
	9,75	GS81256	WS81256	284	375	32	24	2,1	373	300	2,1	301	371
	55,6	GS89456	WS89456	285	520	48	48,5	6	512	311	6	309	508
300	5,92	GS81160	WS81160	304	376	25	18,5	2	373	315	2	316	372
	15,2	GS81260	WS81260	304	415	38	28,5	3	413	328	3	329	412
	60,15	GS89460	WS89460	305	540	48	48,5	6	533	331	6	329	528
320	6,35	GS81164	WS81164	324	396	25	19	2	394	334	2	336	392
	61,5	GS89464	WS89464	325	575	68	43,5	6	573	340	6	343	566

Axial needle roller bearings



Matrix for bearing preselection 1099

1 Axial needle roller bearings **1100**

1.1	Bearing design	1100
1.2	Load carrying capacity	1103
1.3	Compensation of angular misalignments	1103
1.4	Lubrication	1103
1.5	Sealing	1103
1.6	Speeds	1103



1.7	Noise	1104	1.17	Mounting and dismounting	1108
1.8	Temperature range	1104	1.18	Legal notice regarding data freshness	1109
1.9	Cages	1104	1.19	Further information	1109
1.10	Internal clearance	1104	Product tables	1110	
1.11	Dimensions, tolerances	1105	 Axial needle roller and cage assemblies, axial bearing washers	1110	
1.12	Suffixes	1105	Axial needle roller bearings with centring spigot	1112	
1.13	Structure of bearing designation	1106			
1.14	Dimensioning	1106			
1.15	Minimum load	1107			
1.16	Design of bearing arrangements	1107			





























Matrix for bearing preselection

The matrix gives an overview of the types and design features of axial needle roller bearings.

It can be used to make a preliminary assessment of whether a bearing is fundamentally suitable for the envisaged application.

The additional information provided in the product chapter (see column "detailed information") and in the Technical principles must, however, be observed in selection of the bearing.

Design features and suitability			Axial needle roller bearings	
+++ extremely suitable ++ highly suitable + suitable (+) suitable with restrictions - not suitable/not applicable ✓ available			 detailed information ► 1100	
Load carrying capacity	radial		-	► 1103 1.2
	axial, one direction		++	► 1103 1.2
	axial, both directions		-	
	moments		-	
Compensation of angular misalignments	static		-	► 1103 1.3
	dynamic		-	► 1103 1.3
Bearing design	cylindrical bore		✓	► 1100 1.1
	tapered bore		-	
	separable		✓	► 1100 1.1
Lubrication	greased		-	► 1103 1.4
Sealing	open		✓	► 1103 1.5
	non-contact		-	
	contact		-	
Operating temperature in °C		from to 	-20 +120	► 1104 1.8
Suitability for	high speeds		++	► 1103 1.6
	high running accuracy		-	► 1105 1.11 ► 114
	low-noise running		+	► 1104 1.7 ► 27
	high rigidity		+++	► 54
	reduced friction		+++	► 56
	length compensation within bearing		(+)	
	non-locating bearing arrangement		-	
	locating bearing arrangement		-	
X-life bearings		X-life	-	
Inner cage diameter D_{c1} in mm		from to 	4 160	► 1110 ► 1112
Product tables		from page 	1110	



1 Axial needle roller bearings



Axial needle roller bearings are particularly suitable where:

- high axial forces occur in one direction but no radial loads are present (the bearings may only be subjected to axial load ► 1103 | 1.2)
- the load carrying capacity of comparable axial deep groove ball bearings is no longer adequate and the very high axial load carrying capacity of axial cylindrical roller bearings is not yet necessary ► 1100 | 1
- higher speeds occur in addition to high axial loads
- the bearing arrangement must have very high axial rigidity
- the axial space available is extremely small ► 1100 | 1
- the bearing parts can or must be mounted separately
- the bearing arrangement is not configured but, for cost reasons, ready-to-fit standard bearings are to be used.

For an overview of other product-specific features, see the Matrix for bearing preselection ► 1099.

1
Axial needle roller bearing and axial deep groove ball bearing – comparison of load carrying capacity and design envelope

F_a = axial load
 C_a = basic dynamic load rating
 D_w = diameter of needle roller
 T = axial section height of axial deep groove ball bearing

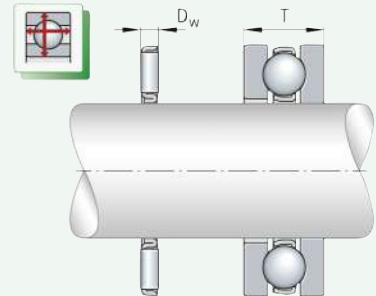
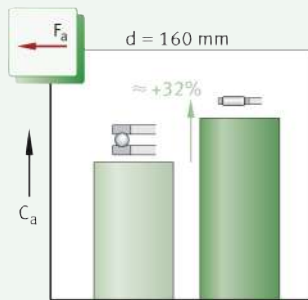

1.1 Bearing design

Design variants

Axial needle roller bearings are available as:

- complete axial needle roller bearings (comprising a needle roller and cage assembly and axial bearing washers) ► 1101 | 2
- individual bearing parts for combination, comprising:
 - axial needle roller and cage assembly (prefix AXK)
 - axial bearing washers (prefix AS) ► 1102 | 3
- bearings with centring spigot (prefix AXW) ► 1102 | 4 and ► 1102 | 5.



Furthermore, Schaeffler supplies axial needle roller bearings by agreement for specific applications, for example with tabs to prevent rotation. Such bearings are used, due to their low axial section height, in applications such as automotive manual gearshift transmissions.

🔗 *Ready-to-fit bearing units with very small axial space*

Axial needle roller bearings

Axial needle roller bearings are part of the group of axial roller bearings. In contrast to the ball, the roller has a larger contact area perpendicular to the roller axis. As a result, it can transmit higher forces, has greater rigidity and allows smaller rolling element diameters under the same load. The single row, ready-to-fit bearings comprise flat, ribless axial bearing washers between which axial needle roller and cage assemblies are arranged ▶ 1101|📐2. Their axial section height corresponds only to the diameter of the needle rollers plus the thickness of the washers. Due to this design, the bearings are extremely small in axial height ▶ 1112|📐3. The rolling elements are retained and guided by axial cages. The needle rollers are made from through hardened rolling bearing steel 100Cr6. They have a hardness of at least 670 HV and profiled ends, i.e. they have a slight lateral curvature towards the ends. The modified line contact between the needle rollers and raceways prevents damaging edge stresses. This in turn has a positive effect on the operating life of the bearings.



Due to the extensive possible combinations, the bearing parts for axial needle roller bearings are always supplied individually, i.e. the corresponding axial needle roller and cage assemblies and axial bearing washers in the product tables must always be ordered together ▶ 1101|📐2, ▶ 1102|📐3, ▶ 1106|1.13 and ▶ 1112|📐3.

📐2 Axial needle roller bearing

F_a = axial load

- ① Axial bearing washers
- ② Axial needle roller and cage assembly

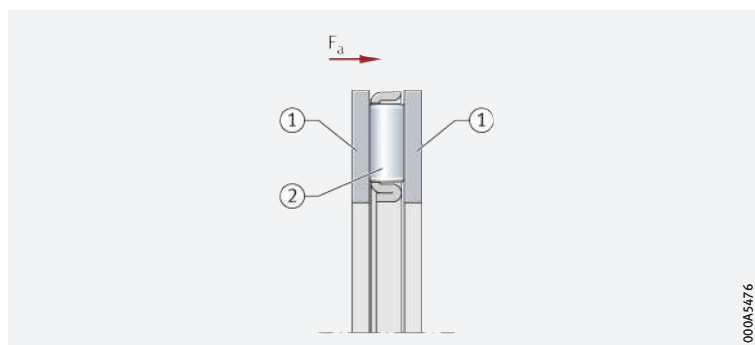

🔗 *The axial section height corresponds to the needle roller diameter*

Axial needle roller and cage assemblies

Axial needle roller and cage assemblies AXK comprise geometrically stable plastic or metal cages fitted with a large number of needle rollers ▶ 1101|📐2. Due to the high uniformity of diameter (the needle rollers are sorted to very small diameter tolerances) of the needle rollers with each other, this gives very uniform loading of the rolling elements ▶ 1105|📐3. Since the axial section height of the cage assemblies is determined purely by the needle roller diameter, the bearings require only an extremely small axial design space.

🔗 *Suitable as a direct bearing arrangement or in conjunction with axial bearing washers*

The axial needle roller and cage assemblies are generally combined with axial bearing washers ▶ 1101|📐2 and ▶ 1102|📐3. If they are to be used directly – i.e. without these washers – in the adjacent construction, the raceway for the needle rollers must be produced as a rolling bearing raceway ▶ 1107|1.16.

🔗 *Suitable as shaft or housing locating washers*

Axial bearing washers

Axial bearing washers AS are suitable for axial needle roller and cage assemblies AXK. They are punched, through hardened, polished and suitable for use as shaft or housing locating washers. Housing locating washers are externally centred, shaft locating washers are internally centred ▶ 1102|📐3 and ▶ 1107|1.16. They are used if the adjacent machine parts cannot be used as a raceway for the rolling elements but are sufficiently rigid and geometrically precise.



The use of complete axial needle roller bearings (axial cylindrical roller and cage assembly AXK with axial bearing washers AS) is only appropriate, for example, if high speeds occur and the bearing washers must therefore be precisely centred or the running surfaces for the rolling elements cannot be configured as a rolling bearing raceway.



Axial bearing washers

- ① Axial needle roller bearing, housing locating washer externally centred
- ② Axial needle roller bearing, shaft locating washer internally centred

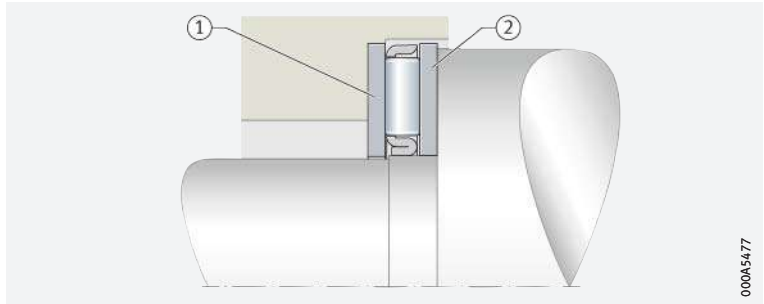

000A5477

☞ *The centring spigot gives simplified mounting of the bearings*

☞ *Suitable for the support of axial loads only*

Axial bearings with centring spigot

Axial needle roller bearings AXW comprise a housing locating washer with a centring spigot into which an axial needle roller and cage assembly AXK is inserted. With the aid of the centring spigot, the housing locating washer can be precisely centred in the housing bore. This gives easier mounting of the bearings. The running surface for the needle roller and cage assembly must be produced as a rolling bearing raceway, i.e. it must be hardened and ground.

Axial bearings with a centring spigot can only support axial loads in one direction. In order to support combined radial/axial loads, however, these bearings can be combined with the following radial needle roller bearings:

- drawn cup needle roller bearings with open ends and with closed end (direct bearing arrangement) ► 1102 | ④
- needle roller bearings with or without inner ring ► 1102 | ⑤

Such combinations give very compact and economical bearing arrangements.



Needle roller axial bearings with centring spigot, combined with drawn cup needle roller bearings with open ends

F_a = axial load
 F_r = radial load

- ① Needle roller axial bearing AXW
- ② Drawn cup needle roller bearing with open ends HK (radial bearing)
- ③ Axial bearing washer AS

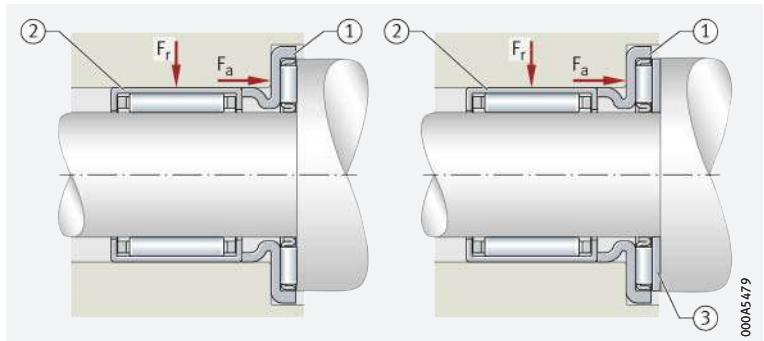

000A5479



Needle roller axial bearings with centring spigot, combined with needle roller bearings

F_a = axial load
 F_r = radial load

- ① Needle roller axial bearing AXW
- ② Needle roller bearing without inner ring (radial bearing)
- ③ Needle roller bearing with inner ring (radial bearing)

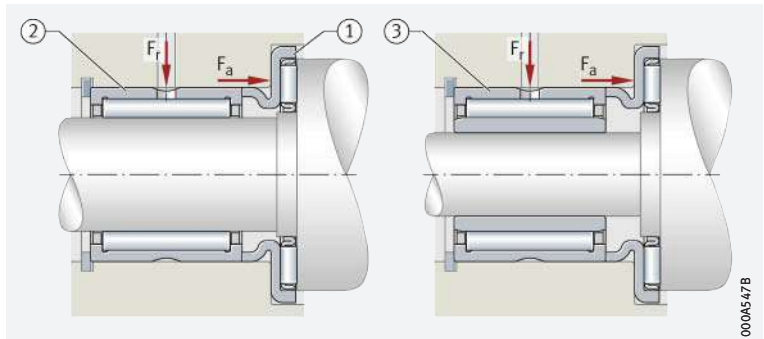

000A547B

1.2 Load carrying capacity

☞ *For high axial loads acting in one direction*

Single row axial needle roller bearings can support high axial loads as well as axial shock loads in one direction, but must not be subjected to radial load ▶ 1106 | 1.14. Radial loads must be supported by means of an additional bearing ▶ 1102 | ☐ 4 and ▶ 1102 | ☐ 5.

1.3 Compensation of angular misalignments



The bearings do not permit any skewing between the shaft and housing. If angular misalignments occur between the locating surfaces on the shaft and in the housing, this will cause damage to the bearing and a reduction in its operating life.



1.4 Lubrication

☞ *Oil or grease lubrication is possible*

☞ *Compatibility with plastic cages*



Axial needle roller bearings and axial needle roller and cage assemblies are not greased. The bearings must be lubricated with oil or grease.

When using bearings with plastic cages, compatibility between the lubricant and the cage material must be ensured if synthetic oils, lubricating greases with a synthetic oil base or lubricants containing a high proportion of EP additives are used.

If there is any uncertainty regarding the suitability of the selected lubricant for the application, please consult Schaeffler or the lubricant manufacturer.

☞ *Observe oil change intervals*

Aged oil and additives in the oil can impair the operating life of plastics at high temperatures. As a result, stipulated oil change intervals must be strictly observed.

1.5 Sealing

☞ *Provide seals in the adjacent construction*

The bearings are not sealed; i. e. sealing of the bearing position must be carried out in the adjacent construction. This must reliably prevent:

- moisture and contaminants from entering the bearing
- the egress of lubricant from the bearing position.

1.6 Speeds

☞ *Limiting speeds and reference speeds in the product tables*

The product tables give two speeds for the bearings ▶ 1110 | ☐ 1:

- the kinematic limiting speed n_G
- the thermal speed rating $n_{\vartheta r}$.

Limiting speed



The limiting speed n_G is the kinematically permissible speed of a bearing. Even under favourable mounting and operating conditions, this value should not be exceeded without prior consultation with Schaeffler ▶ 64. The values in the product tables are valid for oil lubrication.

☞ *Values for grease lubrication*

For grease lubrication, 25% of the value stated in the product tables is permissible in each case.

Reference speeds

☞ *$n_{\vartheta r}$ is used to calculate n_{ϑ}*

The thermal speed rating $n_{\vartheta r}$ is not an application-oriented speed limit, but is a calculated ancillary value for determining the thermally safe operating speed n_{ϑ} ▶ 64.

1.7

Noise

Schaeffler Noise Index

The Schaeffler Noise Index (SGI) is not yet available for this bearing type ▶ 69. The data for these bearing series will be introduced and updated in stages.

Further information:

- **medias** ▶ <https://medias.schaeffler.com>.

1.8

Temperature range

Limiting values

The operating temperature of the bearings is limited by:

- the dimensional stability of the bearing washers and needle rollers
- the cage
- the lubricant.

Possible operating temperatures of axial needle roller bearings

▶ 1104 | 1.

1
Permissible temperature ranges

Operating temperature	Corrosion-resistant design (with Corrotect coating) or polyamide PA66	Bearings with sheet steel cage
	-20 °C to +120 °C	-20 °C to +120 °C



In the event of anticipated temperatures which lie outside the stated values, please contact Schaeffler.

1.9

Cages

The standard cages are made from sheet steel

Standard cages ▶ 1104 | 2. Other cage designs are available by agreement. With such cages, however, suitability for high speeds and temperatures as well as the basic load ratings may differ from the values for the bearings with standard cages.



For high continuous temperatures and applications with difficult operating conditions, bearings with sheet metal cages should be used. If there is any uncertainty regarding cage suitability, please consult Schaeffler.

2
Cage, cage suffix, inner cage diameter

Bearing series	Solid cage made from polyamide PA66	Sheet steel cage	Corrosion-resistant design (with Corrotect coating)
	TV		
	Inner cage diameter		
AXK	up to 8	from 10	Available by agreement
AXW	-	from 10	Available by agreement

1.10

Internal clearance

Axial clearance and preload are determined by the application

In the case of axial needle roller bearings, the internal clearance (axial clearance) is only achieved when the bearings are mounted. The requisite axial clearance of the bearing arrangement is dependent on the application and must take account of the conditions in the bearing arrangement while warm from operation and subjected to load. If axial needle roller bearings are subjected to vibrations while under predominantly static load, for example, they must be lightly preloaded. Preload can be applied, for example, using calibrated sheets (shims). Other suitable means include shaft nuts, disc springs etc. ▶ 1107 | 1.15. It must always be ensured that no slippage occurs in operation between the rolling elements and raceways ▶ 1107 | 1.15.



If there is any uncertainty regarding correct setting, please consult Schaeffler.

1.11 Dimensions, tolerances

Dimension standards



The main dimensions of axial needle roller bearings correspond to ISO 104:2015. The main dimensions of axial needle roller and cage assemblies correspond to DIN 5405-2:2016, while those of axial bearing washers correspond to DIN 5405-3:2016. Axial needle roller bearings with centring spigot are not standardised.

Tolerances



Axial bearing washers adapt to the accuracy of the abutment surface. They are flat under a minimum concentric load of 200 N.

Tolerances for the bore and outside diameter as well as for the width of the bearing parts ▶ 1105 | 3 and ▶ 1105 | 6.

The sort tolerances and sort intervals of the needle roller diameters correspond to ISO 3096:1996 or DIN 5402-3:2012, grade G2.

The diameter sort tolerance of the needle rollers in the axial needle roller and cage assemblies AXW is 2 µm.

3
Tolerances of bearing parts

Series	Bore		Outside diameter		Height	
		Tolerance class		Tolerance class		Deviations mm
AXK	D_{c1}	E11	D_c	c12	D_w	0 -0,01
AXW	D_{c1}	E12	-	-	B	0 -0,2
AS	d	E12	D	e12	B_1	$\pm 0,05$

6
Bearing parts

- ① Axial needle roller and cage assembly AXK
- ② Axial needle roller bearing AXW
- ③ Axial bearing washer AS

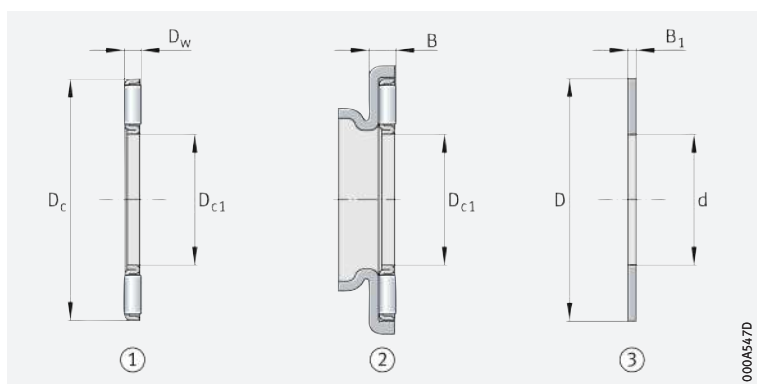

1.12 Suffixes

For a description of the suffixes used in this chapter ▶ 1105 | 4 and **medias** interchange ▶ <https://www.schaeffler.de/std/1D52>.

4
Suffixes and corresponding descriptions

Suffix	Description of suffix	
RR	Corrosion-resistant design, with Corrotect coating	Special design, available by agreement
TV	Plastic cage made from glass fibre reinforced polyamide PA66	Standard

1.13 Structure of bearing designation

Examples of composition of bearing designation

The designation of bearings follows a set model. Examples ▶ 1106 | 7 and ▶ 1106 | 8. The composition of designations for axial needle roller and cage assemblies and axial bearing washers is subject to DIN 623-1 ▶ 102 | 10.

7
Axial needle roller bearing, comprising axial needle roller and cage assembly and axial bearing washers

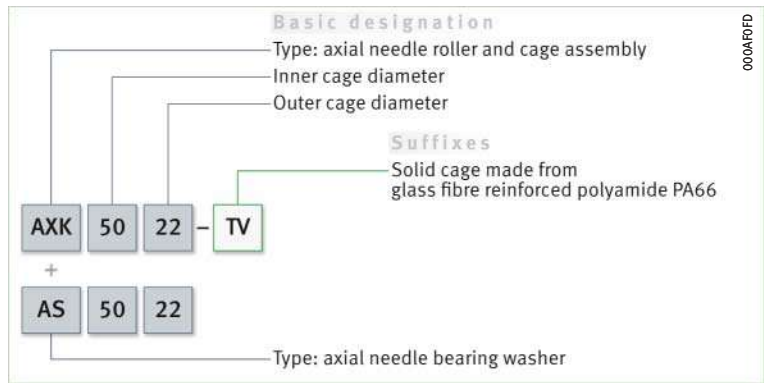

8
Axial needle roller bearing with centring spigot, combined with axial bearing washer and drawn cup needle roller bearing with open ends

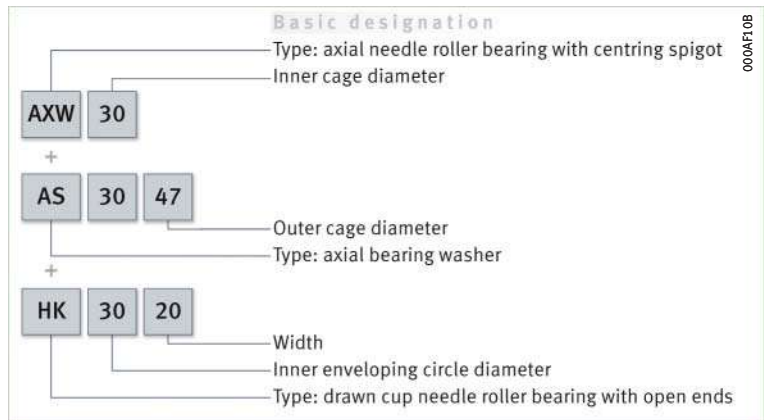

1.14 Dimensioning

Equivalent dynamic bearing load



Axial cylindrical roller bearings can only support axial forces ▶ 1103 | 1.2. In the rating life equation, P is therefore substituted by the value for F_a ▶ 1106 | 1.

f1
Equivalent dynamic load

$$P = F_a$$

Legend

P	N	Equivalent dynamic bearing load
F_a	N	Axial load.

Equivalent static bearing load

Combined loads are not possible

In relation to the direction of load, the same conditions apply as for the equivalent dynamic bearing load, i.e. combined loads are not permissible. In the rating life equation, P_0 is therefore substituted by the value for F_{0a} ▶ 1106 | 2.

f2
Equivalent static load

$$P_0 = F_{0a}$$

Legend

P_0	N	Equivalent static bearing load
F_{0a}	N	Largest axial load present (maximum load).

$$S_0 = C_0/P_0$$

Static load safety factor

In addition to the basic rating life $L(L_{10h})$, it is also always necessary to check the static load safety factor $S_0 \gg 1107$ | f3.

f3
Static load safety factor

$$S_0 = \frac{C_0}{P_0}$$

Legend

S_0	–	Static load safety factor
C_0	N	Basic static load rating
P_0	N	Equivalent static bearing load.

1.15 Minimum load

Rolling bearings under low loads are particularly prone to slippage

In order to prevent slippage damage, the bearing must be subjected to a minimum axial load $F_{a \min} \gg 1107$ | f4. In vertical bearing arrangements in particular, the requisite minimum axial load $F_{a \min}$ is normally achieved, however, simply by the weight of the bearing parts and the external forces. If this is not the case, the bearing arrangement must be preloaded, for example by means of springs or a shaft nut $\gg 1104$ | 1.10.

f4
Minimum axial load

$$F_{a \min} = 0,0005 \cdot C_{0a} + k_a \left(\frac{C_{0a} \cdot n}{10^8} \right)^2$$

Legend

$F_{a \min}$	N	Minimum axial load
C_{0a}	N	Basic static load rating, axial
k_a	–	Factor for determining the minimum load; $k_a = 3$
n	min ⁻¹	Speed.

1.16 Design of bearing arrangements

Design of adjacent parts



Axial needle roller bearings cannot tolerate angular misalignments $\gg 1103$ | 1.3. The locating surfaces for the bearing parts on the shaft and in the housing must therefore be vertical to the shaft axis, while the adjacent parts must be rigid and flat. They must be configured such that the bearing washers are supported as far as possible over the whole circumference and over the whole raceway width.

Running surfaces of rolling elements in direct bearing arrangements with needle roller and cage assemblies

Produce the running surfaces as a rolling bearing raceway

For the very smallest axial design space, axial needle roller and cage assemblies can also run directly (i.e. without axial bearing washers) on the adjacent construction. In this case – and if the load carrying capacity of the axial needle roller and cage assemblies is to be fully utilised – the raceways on the shaft and in the housing must be produced as a rolling bearing raceway or must correspond to the quality and hardness of axial bearing washers. When designing the raceway on the shaft and in the housing, the raceway dimensions E_a and E_b of axial needle roller and cage assemblies must be observed $\gg 1110$ | . If the values are observed, this will ensure that the raceways for the needle rollers – taking account of any possible axial offset of the needle roller and cage assembly – are adequately dimensioned.

☞ Raceway design

Design of running surfaces:

- raceway hardness 670 HV to 840 HV
- radial cage guidance surfaces Ramax 0,8 (Rzmax 4)
- surface hardening depth SHD $\geq 140 \cdot D_w/R_{p0,2}$
 - SHD = surface hardening depth in mm
 - D_w = rolling element diameter in mm
 - $R_{p0,2}$ = proof stress in N/mm²
- roughness Ramax 0,2 (Rzmax 1)
- raceway dimensions E_a and E_b according to the product tables must be observed
- total axial runout tolerances to ISO tolerance grade IT5 (for special requirements IT4) relative to the inside diameter of the axial needle roller and cage assemblies D_{c1} must be observed.

Tolerances for shaft and housing bore

Proven tolerances are given in **► 1108** | **5**. If the data are observed, this will give correct radial guidance of the bearing elements.

5
Tolerances for shafts and housing bores

Bearing component		Tolerance class ¹⁾ for	
		Shaft	Bore
AXK	Shaft guided	h8	–
AS	Externally centred as housing locating washer	Shaft released	H9
	Internally centred as shaft locating washer	h8	Bore released

¹⁾ The envelope requirement **⊗** applies.

☞ Tolerances for the centring spigot in the housing bore

Where axial needle roller bearings AXW are to be combined with drawn cup needle roller bearings with open ends or closed end, or with needle roller bearings, the bore tolerances selected for the bore of the centring spigot in the housing must be the same as for the radial bearings **► 1100** | 1.1, **► 1102** | **⊗** 4 and **► 1102** | **⊗** 5.

☞ Release of shaft and housing locating washers

Release and guidance of bearing parts

If the bearing washers are centred on the shaft, they must have radial clearance in the housing bore while, if they are centred in the housing, there must be radial clearance between the washer bore and the shaft **► 1108** | **5**.

☞ Guidance of axial needle roller and cage assemblies

In order to achieve the lowest possible sliding speeds on the guidance surfaces, the axial needle roller and cage assemblies are generally guided on the shaft. This is particularly important in the case of high speeds.

1.17 Mounting and dismounting



The mounting and dismounting options for the bearings must be taken into consideration in the design of the bearing position.

☞ As the bearings are not self-retaining, they are easy to mount

Axial needle roller bearings are not self-retaining. As a result, the bearing parts can be mounted separately from each other. This gives simplified mounting of the bearings.

☞ Mounting position of bearing washers

The axial bearing washers AS must be suitable as a raceway on both sides, i.e. either side of the washer can face towards the needle rollers.

 *Rolling bearings must be handled with great care*

Schaeffler Mounting Handbook

Rolling bearings are well-proven precision machine elements for the design of economical and reliable bearing arrangements, which offer high operational security. In order that these products can function correctly and achieve the envisaged operating life without detrimental effect, they must be handled with care.



The Schaeffler Mounting Handbook MH 1 gives comprehensive information about the correct storage, mounting, dismounting and maintenance of rotary rolling bearings ► <https://www.schaeffler.de/std/1D53>. It also provides information which should be observed by the designer, in relation to the mounting, dismounting and maintenance of bearings, in the original design of the bearing position. This book is available from Schaeffler on request.



1.18 Legal notice regarding data freshness

 *The further development of products may also result in technical changes to catalogue products*

Of central interest to Schaeffler is the further development and optimisation of its products and the satisfaction of its customers. In order that you, as the customer, can keep yourself optimally informed about the progress that is being made here and with regard to the current technical status of the products, we publish any product changes which differ from the printed version in our electronic product catalogue.



We therefore reserve the right to make changes to the data and illustrations in this catalogue. This catalogue reflects the status at the time of printing. More recent publications released by us (as printed or digital media) will automatically precede this catalogue if they involve the same subject. Therefore, please always use our electronic product catalogue to check whether more up-to-date information or modification notices exist for your desired product.

Link to electronic product catalogue



The following link will take you to the Schaeffler electronic product catalogue: ► <https://medias.schaeffler.com>.

1.19 Further information



In addition to the data in this chapter, the following chapters in Technical principles must also be observed in the design of bearing arrangements:

- Determining the bearing size ► 34
- Rigidity ► 54
- Friction and increases in temperature ► 56
- Speeds ► 64
- Bearing data ► 97
- Lubrication ► 70
- Sealing ► 182
- Design of bearing arrangements ► 139
- Mounting and dismounting ► 191.



Axial needle roller and cage assemblies Axial bearing washers

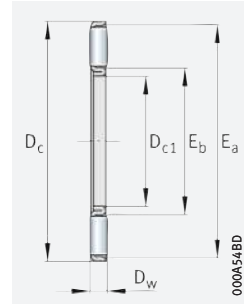

AXK

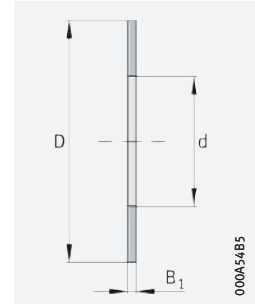

AS

$D_{c1} = 4 - 160 \text{ mm}$

Main dimensions				Basic load ratings		Fatigue limit load	Limiting speed	Speed rating
D_{c1} d	D_c D	D_w	B_1	dyn. C_a N	stat. C_{0a} N	C_{ua} N	n_G min^{-1}	$n_{\theta r}$ min^{-1}
4	14	2	1	4 400	8 000	940	21 500	15 100
5	15	2	1	4 750	9 200	1 070	20 600	13 100
6	19	2	1	6 800	15 500	1 580	18 900	11 000
8	21	2	1	7 800	19 400	1 970	17 800	8 900
10	24	2	1	9 200	25 500	2 500	16 900	7 400
12	26	2	1	9 900	29 000	2 850	15 200	6 500
15	28	2	1	11 300	36 000	3 600	13 200	4 950
17	30	2	1	11 900	39 500	3 950	12 100	4 500
20	35	2	1	13 100	46 500	4 750	10 500	4 350
25	42	2	1	14 700	58 000	5 900	8 400	3 700
30	47	2	1	16 300	70 000	7 100	7 300	3 100
35	52	2	1	17 800	81 000	8 300	6 500	2 700
40	60	3	1	28 000	114 000	11 800	5 600	2 340
45	65	3	1	30 000	128 000	13 300	5 100	2 100
50	70	3	1	32 000	143 000	14 800	4 700	1 890
55	78	3	1	38 000	186 000	20 300	4 250	1 730
60	85	3	1	44 500	234 000	26 500	3 900	1 550
65	90	3	1	46 500	255 000	28 500	3 650	1 430
70	95	4	1	54 000	255 000	26 500	3 450	1 400
75	100	4	1	55 000	265 000	28 000	3 250	1 340
80	105	4	1	56 000	280 000	29 500	3 100	1 260
85	110	4	1	58 000	290 000	30 500	2 950	1 200
90	120	4	1	73 000	405 000	44 500	2 700	1 100
100	135	4	1	91 000	560 000	58 000	2 420	970
110	145	4	1	97 000	620 000	63 000	2 230	880
120	155	4	1	102 000	680 000	68 000	2 070	800
130	170	5	1	133 000	840 000	75 000	1 900	750
140	180	5	1	138 000	900 000	79 000	1 780	700
150	190	5	1	143 000	960 000	82 000	1 680	660
160	200	5	1	148 000	1 020 000	86 000	1 590	620

medias ► <https://www.schaeffler.de/std/1D9C>

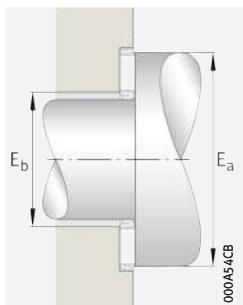

Mounting dimensions/raceway dimensions for direct bearing arrangement



d D _{c1}	Axial needle roller and cage assemblies		Axial bearing washers		Raceway dimensions	
	Mass m ≈ g	Designation ▶ 1105 1.12 ▶ 1106 1.13	Mass m ≈ g	Designation ▶ 1105 1.12 ▶ 1106 1.13	E _b	E _a
4	0,7	AXK0414-TV	1	AS0414	5	13
5	0,8	AXK0515-TV	1	AS0515	6	14
6	1	AXK0619-TV	2	AS0619	7	18
8	2	AXK0821-TV	2	AS0821	9	20
10	3	AXK1024	3	AS1024	12	23
12	3	AXK1226	3	AS1226	14	25
15	4	AXK1528	3	AS1528	17	27
17	4	AXK1730	4	AS1730	19	29
20	5	AXK2035	5	AS2035	22	34
25	7	AXK2542	7	AS2542	29	41
30	8	AXK3047	8	AS3047	34	46
35	10	AXK3552	9	AS3552	39	51
40	16	AXK4060	12	AS4060	45	58
45	18	AXK4565	13	AS4565	50	63
50	20	AXK5070	14	AS5070	55	68
55	28	AXK5578	18	AS5578	60	76
60	33	AXK6085	22	AS6085	65	83
65	35	AXK6590	24	AS6590	70	88
70	60	AXK7095	25	AS7095	74	93
75	61	AXK75100	27	AS75100	79	98
80	63	AXK80105	28	AS80105	84	103
85	67	AXK85110	29	AS85110	89	108
90	86	AXK90120	39	AS90120	94	118
100	104	AXK100135	50	AS100135	105	133
110	122	AXK110145	55	AS110145	115	143
120	131	AXK120155	59	AS120155	125	153
130	205	AXK130170	65	AS130170	136	167
140	219	AXK140180	79	AS140180	146	177
150	232	AXK150190	84	AS150190	156	187
160	246	AXK160200	89	AS160200	166	197



Axial needle roller bearings

With centring spigot

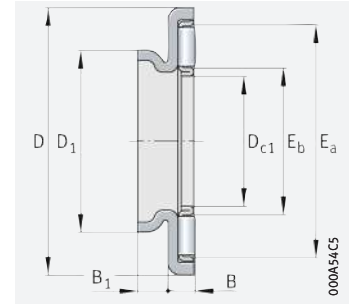

AXW

$D_{c1} = 10 - 50 \text{ mm}$

Main dimensions			Basic load ratings		Fatigue limit load C_{ua} N	Limiting speed n_G min^{-1}	Speed rating n_{gr} min^{-1}	Mass m $\approx \text{g}$	Designation ► 1105 1.12 ► 1106 1.13
D_{c1}	D	B	dyn. C_a N	stat. C_{0a} N					
10	27	3,2	9 200	25 500	2 500	16 900	9 300	8,3	AXW10
12	29	3,2	9 900	29 000	2 850	15 200	8 100	9,1	AXW12
15	31	3,2	11 300	36 000	3 600	13 200	6 200	10	AXW15
17	33	3,2	11 900	39 500	3 950	12 100	5 600	11	AXW17
20	38	3,2	13 100	46 500	4 750	10 500	5 300	14	AXW20
25	45	3,2	14 700	58 000	5 900	8 400	4 350	20	AXW25
30	50	3,2	16 300	70 000	7 100	7 300	3 650	22	AXW30
35	55	3,2	17 800	81 000	8 300	6 500	3 150	27	AXW35
40	63	4,2	28 000	114 000	11 800	5 600	2 700	39	AXW40
45	68	4,2	30 000	128 000	13 300	5 100	2 400	43	AXW45
50	73	4,2	32 000	143 000	14 800	4 700	2 160	49	AXW50

medias ► <https://www.schaeffler.de/std/1D9D>



Combination
with radial needle
roller bearings,
drawn cup needle
roller bearings
with open ends,
drawn cup needle
roller bearings
with closed end

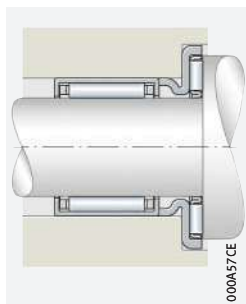

AXW with HK

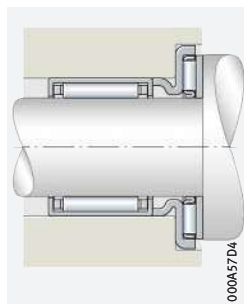

AXW with AS and HK

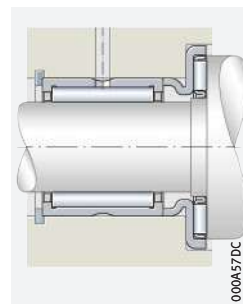

AXW with NK, NKS,
RNA49, RNA69



Dimensions			Raceway dimensions		Axial bearing washers	Drawn cup needle roller bearings with open ends		Drawn cup needle roller bearings with closed end	Needle roller bearings	
D_{c1}	D_1	B_1	E_b	E_a	► 1110 AS	► 886 HK HK...-RS		► 886 BK	► 914 NK, NKS, RNA49, RNA69 NKI, NKIS, NA49, NA69	
10	14	3	12	23	AS1024	HK1010 HK1012 HK1015	–	BK1010 BK1012 BK1015	NK7/10-TV NK7/12-TV	–
12	16	3	14	25	AS1226	HK1210	–	BK1210	NK9/12-TV NK9/16-TV	NKI6/12-TV NKI6/16-TV
15	21	3,5	17	27	AS1528	HK1512 HK1516 HK1522-ZW	HK1514-RS	BK1512 BK1516	–	–
17	23	3,5	19	29	AS1730	HK1712	–	–	NK15/16 NK15/20	–
20	26	3,5	22	34	AS2035	HK2012 HK2016 HK2020 HK2030-ZW	HK2018-RS	BK2016 BK2020	NK18/16 NK18/20	–
25	32	4	29	41	AS2542	HK2512 HK2516 HK2520 HK2526 HK2538-ZW	HK2518-RS	BK2520 BK2526 BK2538-ZW	NK24/16 NK24/20 NKS20	NKI20/16 NKI20/20
30	37	4	34	46	AS3047	HK3012 HK3016 HK3020 HK3026 HK3038-ZW	HK3018-RS	BK3012 BK3016 BK3020 BK3026 BK3038-ZW	NK28/20 NK28/30 NKS24 RNA4904 RNA6904	NA4904 NA6904
35	42	4	39	51	AS3552	HK3512 HK3516 HK3520	HK3518-RS	BK3520	NK32/20-TV NK32/30 NKS28 RNA4905 RNA6905	NKIS20 NA4905 NA6905 NKI28/20-TV NKI28/30
40	47	4	45	58	AS4060	HK4012 HK4016 HK4020	HK4018-RS	BK4020	NK37/20 NK37/30 NKS32 RNA4906 RNA6906	NKIS25 NA4906 NA6906 NKI32/20 NKI32/30
45	52	4	50	63	AS4565	HK4516 HK4520	HK4518-RS	BK4520	NK42/20 NK42/30 NKS37 RNA49/32 RNA69/32-ZW	NKIS30 NA49/32 NA69/32-ZW
50	58	4,5	55	68	AS5070	HK5020 HK5025	HK5022-RS	–	NKS43	NKIS35

Axial spherical roller bearings



Matrix for bearing preselection 1117

1 Axial spherical roller bearings 1118

- 1.1 Bearing design 1118
- 1.2 Load carrying capacity 1120
- 1.3 Compensation of angular misalignments 1121
- 1.4 Lubrication 1121
- 1.5 Sealing 1122
- 1.6 Speeds 1122



1.7	Noise	1122	1.17	Mounting and dismounting	1128
1.8	Temperature range	1123	1.18	Legal notice regarding data freshness	1129
1.9	Cages	1123	1.19	Further information	1129
1.10	Internal clearance	1123		Product tables	
1.11	Dimensions, tolerances	1123		<i>Axial spherical roller bearings</i>	1130
1.12	Suffixes	1124			
1.13	Structure of bearing designation	1125			
1.14	Dimensioning	1125			
1.15	Minimum load	1126			
1.16	Design of bearing arrangements	1127			





Matrix for bearing preselection

The matrix gives an overview of the types and design features of axial spherical roller bearings.

It can be used to make a preliminary assessment of whether a bearing is fundamentally suitable for the envisaged application.

The additional information provided in the product chapter (see column "detailed information") and in the Technical principles must, however, be observed in addition to this overview in selection of the bearing.

Design features and suitability			Axial spherical roller bearings	
+++ extremely suitable ++ highly suitable + suitable (+) suitable with restrictions - not suitable/not applicable available ✓ available			detailed information 1118	
Load carrying capacity	radial		+	➤ 1120 1.2
	axial, one direction		+++	➤ 1120 1.2
	axial, both directions		-	➤ 1120 1.2
	moments		-	
Compensation of angular misalignments	static		+++	➤ 1121 1.3
	dynamic		+	➤ 1121 1.3
Bearing design	cylindrical bore		✓	➤ 1118 1.1
	tapered bore		-	
	separable		✓	➤ 1128 1.17
Lubrication	greased		-	➤ 1121 1.4
Sealing	open		✓	➤ 1122 1.5
	non-contact		-	➤ 1122 1.5
	contact		-	➤ 1122 1.5
Operating temperature in °C		from to	-30 +200	➤ 1123 1.8
Suitability for	high speeds		+	➤ 1122 1.6
	high running accuracy		+	➤ 1123 1.11 ➤ 114
	low-noise running		(+)	➤ 1122 1.7 ➤ 27
	high rigidity		++	➤ 54
	reduced friction		++	➤ 56
	length compensation within bearing		-	
	non-locating bearing arrangement		-	
	locating bearing arrangement		(+)	➤ 139
X-life bearings			✓	➤ 1119
Bearing bore d in mm		from to	60 1600	➤ 1130
Product tables		from page	1130	



1 Axial spherical roller bearings



Axial spherical roller bearings are suitable where:

- bearing arrangements are subjected to high and very high axial loads ▶ 1120|1.2
- dynamic or static misalignments of the shaft relative to the housing, or deflections of the shaft, must be compensated by the bearing under axial loads ▶ 1121|1.3
- radial loads occur in addition to axial forces (maximum 55% of F_a) ▶ 1120|1.2
- a relatively high speed suitability is required in addition to a high load carrying capacity ▶ 1122|1.6
- high shock type loads must be supported
- bearing parts are to be mounted separately (the bearings are not self-retaining) ▶ 1118|1.1.

For an overview of other product-specific features, see the Matrix for bearing preselection ▶ 1117.

1
Axial spherical roller bearing: comparison of load carrying capacity with axial deep groove ball bearing, compensation of misalignments

F_a = axial load
 C_a = basic axial dynamic load rating

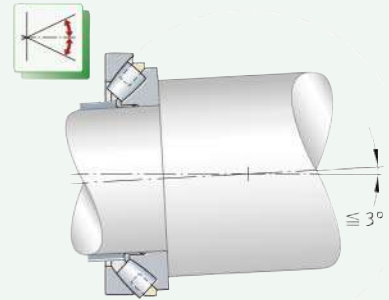
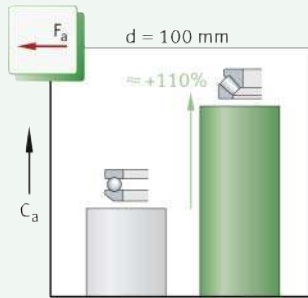

1.1 Bearing design

Design variants

Axial spherical roller bearings are available in the basic design as:

- an increased capacity design with sheet steel cage or solid brass cage ▶ 1119|2.

X-life bearings

The bearings are available in the majority of sizes as X-life bearings ▶ 1119|3.



The bearing design is dependent on the bearing series and the bearing size. It essentially differs in the configuration and guidance of the cage ▶ 1123|1.9.

☞ *The raceway in the housing locating washer has a curved form*

Bearings of basic design

Axial spherical roller bearings are part of the group of axial roller bearings. These single row, non-self-retaining rolling bearings comprise solid shaft and housing locating washers with raceways for the rolling elements. Cages guide the large number of asymmetrical barrel rollers ➤ 1123|1.9. The cage, roller and cage assembly, and shaft locating washer form a self-retaining unit. The raceways are arranged oblique to the bearing axis, the raceway in the housing locating washer is of a concave design. This design allows these bearings to combine a range of characteristics, which are essential to many applications, in one bearing, such as angular adjustability for example ➤ 1121|1.3.

☞ *Roller contact design*

The stress distribution at the contact points between the rollers and raceways is determined by the contact surface of the rollers. As a result, the roller geometry is matched to the raceway. This gives a favourable load distribution over the entire length of the roller and thus prevents both edge stresses and stress peaks at the ends of the roller.

☞ *Bearings with sheet steel cage*

Increased capacity design with sheet steel cage or solid brass cage

Bearings without a cage suffix have coated sheet steel cages, which are guided by rollers ➤ 1119|☐ 2 and ➤ 1123|1.9. These designs are available as X-life bearings ➤ 1119.

☞ *Bearings with solid brass cage*

Bearings with the cage suffix MB have solid brass cages that are guided on the shaft locating washer or by the rollers ➤ 1119|☐ 2 and ➤ 1123|1.9. The MB design is also available in numerous sizes as X-life bearings ➤ 1119.

☐ 2
Axial spherical roller bearings of basic design

F_r = radial load
 F_a = axial load

- ① Increased capacity design, with sheet steel cage
- ② Increased capacity design, with solid brass cage

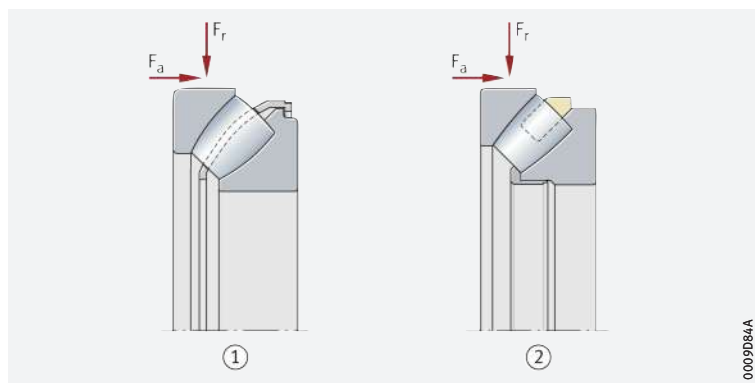

X-life

X-life premium quality

X-life bearings exhibit considerably higher performance than conventional axial spherical roller bearings. This is achieved, for example, through the modified internal construction, the optimised contact geometry between the rollers and raceways, the new cage design, a higher steel quality, better surface quality and optimised roller guidance and lubricant film formation.

☐ 3
Axial spherical roller bearing in X-life design

- ① Cage
- ② Barrel roller
- ③ Housing locating washer
- ④ Shaft locating washer



 *Increased customer benefits due to X-life*

Advantages



These technical enhancements offer a range of advantages, such as:

- a more favourable load distribution in the bearing and thus a higher dynamic load carrying capacity of the bearings
- downsizing possible, increased performance density
- a higher fatigue limit load
- a higher running accuracy and smooth running
- running with reduced friction and greater energy efficiency
- lower heat generation in the bearing
- higher possible speeds
- lower lubricant consumption and therefore longer maintenance intervals if relubrication is carried out
- a measurably longer operating life of the bearings
- high operational security
- compact, environmentally-friendly bearing arrangements.

 *Lower operating costs, higher machine availability*

In conclusion, these advantages improve the overall cost-efficiency of the bearing position significantly and thus bring about a sustainable increase in the efficiency of the machine and equipment.

 *Suffix XL*

X-life axial spherical roller bearings include the suffix XL in the designation  1124 | 1.12 and  1130 | .

 *Wide application range*

Areas of application

Due to their special technical features, X-life axial spherical roller bearings are highly suitable for bearing arrangements in:

- refiners and worm extruders in the pulp and paper industry
- drilling rigs and roll pressers in the cement industry, mining and raw material processing
- work rolls and back-up rolls in cold rolling mills
- extruder gearboxes in chemical plant and refineries
- air preheaters in thermal power stations
- POD and azimuth drives in marine propulsion systems.





X-life indicates a high product performance density and thus a particularly significant benefit to the customer. Further information on X-life  10.





1.2

Load carrying capacity

 *Designed for very high axial loads and high radial loads*

Axial spherical roller bearings can support very high axial loads in one direction and – since the raceways are inclined relative to the bearing axis – radial loads acting simultaneously. They are designed for very high load carrying capacity and, since they have the maximum possible number of large and long barrel rollers, are also suitable for the heaviest loads. As a result of the inclined raceways, the load is transmitted from one raceway to the other oblique to the bearing axis  1121 |  4. Due to the optimised osculation conditions between the rollers and raceways, uniform stress distribution is achieved in the bearing.



The radial load (F_r , F_{0r}) must not exceed 55% of the axial load  1125 |  1 and  1125 |  2.



Force flow under axial load

The load is transmitted from one raceway to the other oblique to the bearing axis.

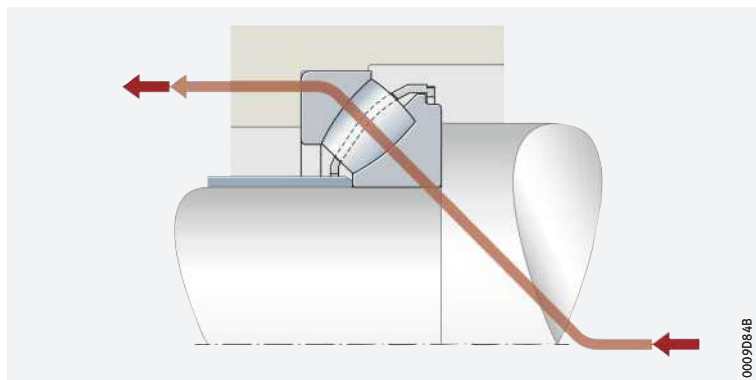

0009D84B

1.3 Compensation of angular misalignments

⊞ Axial spherical roller bearings compensate dynamic and static angular misalignments

Due to the concave rolling element raceway in the housing locating washer, axial spherical roller bearings are capable of angular adjustment. As a result, they permit skewing between the shaft locating washer and housing locating washer within certain limits, without causing damage to the bearings or impairing their function. In this way, they can compensate misalignment, shaft deflection and housing deformation ► 1121 | 1. The extent to which these table values can be used in practice is, however, essentially dependent on the design of the bearing arrangement, the type of seal and other factors.

Permissible adjustment angle

The adjustment angles given in the table are permissible under the following conditions:

- P or $P_0 \leq 0,05 \cdot C_{0a}$
- The angular deviation is constant (static angular misalignment).
- The rotating component is the shaft locating washer.



Permissible skewing under static misalignment

D = bearing outside diameter

Bearing series	Permissible skewing	
	$D < 320$ mm	$D \geq 320$ mm
292..-E1	1,5°	1°
293..-E1	2,5°	1,5°
294..-E1	3°	2°



If the rotating component is the housing locating washer or the shaft locating washer undergoes tumbling motion, the angular adjustment facility is smaller. In such cases, please consult Schaeffler.

1.4 Lubrication

⊞ Oil lubrication is predominantly used

⊞ Pay attention to the pumping action in bearings with oil lubrication

Axial spherical roller bearings are not greased. They are generally lubricated using oil. In some cases, lubrication with greases containing EP additives is also possible. In this instance, however, it must be ensured that the contact points between the rollers and the guidance rib are always adequately supplied with grease. This is best achieved if the bearing is completely filled with grease and regularly relubricated.

Due to their internal construction, a pumping action occurs in bearings with an asymmetrical cross-section. This pumping action, which is heavily dependent on the circumferential speed, can be used under certain conditions to generate oil recirculation in the bearing ► 1122 | 5. The pumping action is present in bearing arrangements with a horizontal and vertical shaft and must be taken into account when selecting the lubrication and sealing method.

! The volume flow generated by the bearings can easily reach a throughput of > 50 l/min. In order to give appropriate possibilities for compensation, ducts for the purposes of oil return must therefore be included in the housing **► 1122 | 5**.

@ If there is any uncertainty regarding the suitability of the selected lubricant for the application, please consult Schaeffler or the lubricant manufacturer.

5
Oil recirculation by means of pumping action, ducts for the purposes of oil return

- ① Bearing arrangement with horizontal shaft
- ② Bearing arrangement with vertical shaft

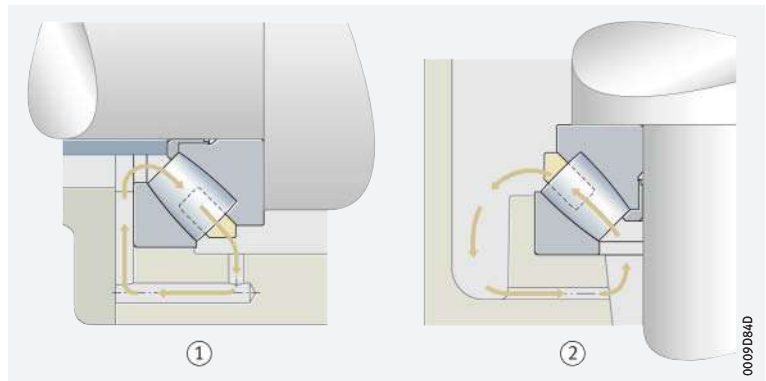

1.5 Sealing

@ The bearings are of an open design; provide seals in the adjacent construction

Axial spherical roller bearings are supplied without seals. In the case of unsealed bearings, sealing of the bearing position must be carried out in the adjacent construction. The sealing system should reliably prevent:

- moisture and contaminants from entering the bearing
- the egress of lubricant from the bearing position.

1.6 Speeds

@ Speeds in the product tables

The achievable operating speed is dependent on the application, the associated loads and the lubrication. The product tables generally give two speeds for the bearings **► 1130 | 6**:

- the kinematic limiting speed n_G
- the thermal speed rating $n_{\vartheta r}$.

Limiting speeds

! The limiting speed n_G is the kinematically permissible speed of the bearing. Even under favourable mounting and operating conditions, this value should not be exceeded without prior consultation with Schaeffler **► 64**.

Reference speeds

@ $n_{\vartheta r}$ is used to calculate n_{ϑ}

The thermal speed rating $n_{\vartheta r}$ is not an application-oriented speed limit, but is a calculated ancillary value for determining the thermally safe operating speed n_{ϑ} **► 64**.

1.7 Noise

Schaeffler Noise Index

The Schaeffler Noise Index (SGI) is not yet available for this bearing type **► 69**. The data for these bearing series will be introduced and updated in stages.

Further information:

- **medias** **►** <https://medias.schaeffler.com>.

1.8 Temperature range

Limiting values

The operating temperature of the bearings is limited by:

- the dimensional stability of the bearing rings and rolling elements
- the cage
- the lubricant.

Possible operating temperatures of axial spherical roller bearings

► 1123 | 2.

 2
Permissible temperature ranges

Operating temperature	Axial spherical roller bearings with sheet steel or brass cage
	-30 °C to +200 °C, limited by the lubricant



In the event of anticipated temperatures which lie outside the stated values, please contact Schaeffler.

1.9 Cages

Sheet steel cages or solid brass cages are used as standard

Axial spherical roller bearings essentially differ in terms of their cage design ► 1119 | 2. The design is dependent on the bearing series and the bearing size ► 1123 | 3. Sheet steel cages do not have a cage suffix in the designation ► 1123 | 3. The cages have a high strength. They are suitable for high temperatures and all conventional lubricants.



If there is any uncertainty regarding cage suitability for a specific application, please consult Schaeffler.

 3
Cage, cage suffix, bore code

Bearing series	Sheet steel cage	Solid brass cage
	MB	
	Bore code	
292..-E1	-	30 to /1180
293..-E1-XL	17 to 64	68 to /800
293..-E1	-	/850 to /1600
294..-E1-XL	12 to 68	72 to /710
294..-E1	-	/750 to /1060

1.10 Internal clearance

The possible preload is determined by the application

In the case of axial spherical roller bearings, the axial preload is achieved when the bearings are mounted. The requisite preload is dependent on the application and must take account of the conditions in the bearing arrangement while warm from operation and subjected to load. It must always be ensured that no slippage occurs in operation between the rolling elements and raceways. A specific minimum axial load $F_{a\min}$ must be acting on axial spherical roller bearings at all times ► 1126 | 1.15.



If there is any uncertainty regarding preload, please consult Schaeffler.

1.11 Dimensions, tolerances

Dimension standards



The main dimensions of axial spherical roller bearings correspond to ISO 104:2015 and DIN 728:1991.

Chamfer dimensions



The limiting dimensions for chamfer dimensions correspond to DIN 620-6:2004. Overview and limiting values ► 138. Nominal value of chamfer dimension ► 1130 | 3.

Tolerances



The dimensional and running tolerances of shaft and housing locating washers correspond to the tolerance class Normal in accordance with ISO 199:2014 ▶ 133 | 25 to ▶ 135 | 28.

ⓘ *Restricted section height tolerance*

The tolerances for section height T are considerably restricted for all axial spherical roller bearings compared to the standard values ▶ 1124 | 4 and ▶ 1130 | 4.

4
Tolerances for bearing section height

Nominal bore diameter mm		Deviation of bearing section height T μm	
over	incl.	upper	lower
50	80	0	-100
80	120	0	-100
120	180	0	-125
180	250	0	-125
250	315	0	-150
315	400	0	-200
400	500	0	-420
500	630	0	-500
630	800	0	-630
800	1 000	0	-800
1 000	1 250	0	-1 000
1 250	1 600	0	-1 200

1.12 Suffixes

For a description of the suffixes used in this chapter ▶ 1124 | 5 and **medias** interchange ▶ <https://www.schaeffler.de/std/1D52>.

5
Suffixes and corresponding descriptions

Suffix	Description of suffix	
E1	Increased capacity design	Standard
MB	Solid brass cage	
N1	One retaining slot in the housing locating washer	
N2	Two retaining slots offset by 180° in the housing locating washer	
THI	3 uniformly distributed threaded holes in one end face of the shaft locating washer	
THIE	3 uniformly distributed threaded holes in one end face of the shaft locating washer, incl. suitable eye bolts	
THO	3 uniformly distributed threaded holes in one end face of the housing locating washer	
THOE	3 uniformly distributed threaded holes in one end face of the housing locating washer, incl. suitable eye bolts	
XL	X-life bearing	

1.13 Structure of bearing designation

Examples of composition of bearing designation

The designation of bearings follows a set model. Examples ▶ 1125 | 6 and ▶ 1125 | 7. The composition of designations is subject to DIN 623-1 ▶ 102 | 10.

6
Axial spherical roller bearing,
X-life design:
designation structure

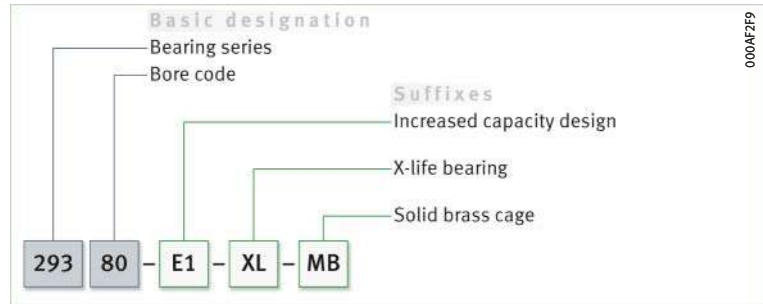

7
Axial spherical roller bearing,
X-life design, with retaining slot
and threaded holes:
designation structure

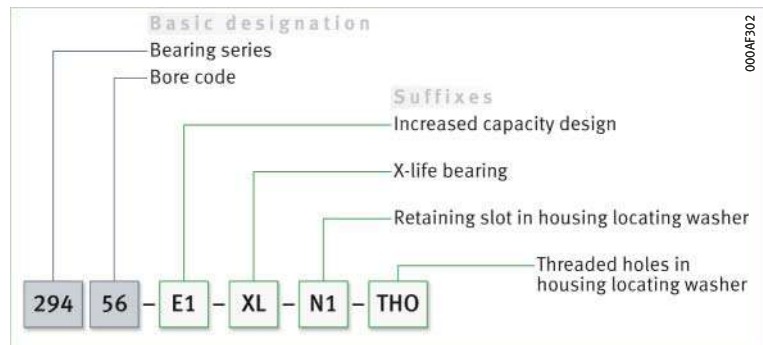

1.14 Dimensioning

$P = a$ substitute force for combined load and various load cases

Equivalent dynamic bearing load

The basic rating life equation $L = (C/P)^P$ used in the dimensioning of bearings under dynamic load assumes a load of constant magnitude and direction. In axial bearings, this is a purely axial and concentrically acting load. If this condition is not met, an equivalent dynamic bearing load P must be determined for the rating life calculation. In the case of axial bearings, this is a concentrically acting axial load of constant magnitude and direction, which has the same effect on the rating life as the load occurring in practice. Calculation ▶ 1125 | 1.

f1
Equivalent dynamic load

$$P = F_a + 1,2 \cdot F_r$$

Legend

P	N	Equivalent dynamic bearing load
F_r	N	Radial load
F_a	N	Axial load.



The radial bearing load F_r must not exceed 55% of the axial load F_a :
 $F_r \leq 0,55 \cdot F_a$

Equivalent static bearing load

For axial spherical roller bearings subjected to static load ▶ 1125 | 2.

f2
Equivalent static load

$$P_0 = F_{0a} + 2,7 \cdot F_{0r}$$

Legend

P_0	N	Equivalent static bearing load
F_{0r}, F_{0a}	N	Largest radial or axial load present (maximum load).



The radial bearing load F_{0r} must not exceed 55% of the axial load F_{0a} :
 $F_{0r} \leq 0,55 \cdot F_{0a}$

Static load safety factor



In addition to the basic rating life L_{10h} , it is also always necessary to check the static load safety factor S_0 . The following values must be observed here ▶ 1126 | 6. Calculation of S_0 ▶ 1126 | 3.

f 3
Static load safety factor

$$S_0 = \frac{C_0}{P_0}$$

Legend

S_0	-	Static load safety factor
C_0	N	Basic static load rating
P_0	N	Equivalent static bearing load.

6
Values for static load safety factor

Static load safety factor S_0	Conditions
$S_0 \geq 8$	Axial support by the abutment shoulders in accordance with the product tables (d_a and D_a) ▶ 1130 6
$S_0 \geq 6$	Full axial support of the housing and shaft locating washers by the entire mating surface, dimensions D_1 and d_1 ▶ 1130 6
$S_0 \geq 4$	Full axial support, dimensions D_1 and d_1 ▶ 1130 6 together with good radial support of the housing locating washer (housing tolerance K7)

1.15 Minimum load

Rolling bearings under low loads are particularly prone to slippage

If the lubricant film is interrupted between the rolling elements and raceways as a result of slippage, the contact partners will come into contact at high relative velocity and the wear in the bearing will increase abruptly. The risk of slippage is particularly high where bearings are subjected to low loads. In order to prevent slippage damage and guarantee kinematics, a minimum axial load $F_{a \min}$ must therefore be applied to the bearing ▶ 1126 | 4 and ▶ 1127 | 7.

Preload the bearings, if the minimum axial load is not achieved

In vertical bearing arrangements in particular, the requisite minimum axial load $F_{a \min}$ is normally already achieved by the weight of the supported parts and the external forces. If this is not the case, the bearing arrangement must be preloaded, for example by means of springs or a shaft nut ▶ 1126 | 8 and ▶ 1123 | 1.10. The minimum axial load must be ensured in all operating modes.

8
Minimum axial load applied to an axial spherical roller bearing by means of spring preload

① Pressure springs distributed uniformly around the circumference of the housing locating washer

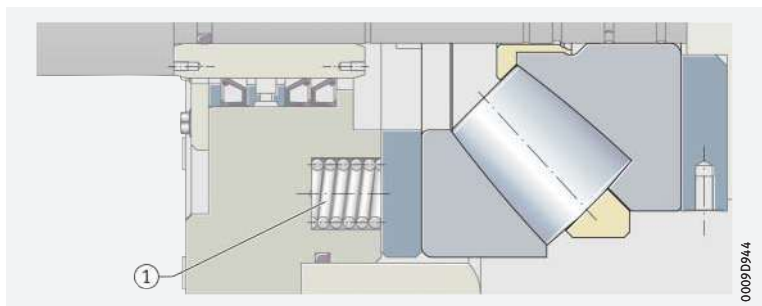

f 4
Minimum axial load

$$F_{a \min} = 0,0005 \cdot C_{0a} + k_a \left(\frac{C_{0a} \cdot n}{10^8} \right)^2$$

Legend

$F_{a \min}$	N	Minimum axial load
C_{0a}	N	Basic static load rating ▶ 1130 6
k_a	-	Factor for determining the minimum load ▶ 1127 7
n	min^{-1}	Speed.

7
Factor k_a for calculating the minimum axial load

Bearing series	Factor k_a
292..-E1	0,6
293..-E1	0,9
294..-E1	0,7

1.16 Design of bearing arrangements

Support bearing washers over the circumference and width

Design of adjacent parts

The adjacent parts to the shaft and housing locating washers must be rigid, flat and perpendicular to the axis of rotation. They must be configured such that the bearing washers are supported over the whole circumference and over the whole raceway width; in particular, this must be observed under high loads. The axial runout tolerances of the contact surfaces for axial spherical roller bearings should be designed to IT5 or better **1127**.



The housing bore must have a recess with a diameter $D_{b \min}$ above the housing locating washer, otherwise the rollers may graze the housing in the event of shaft misalignments **1127**. Dimensions for $D_{b \min}$ **1130**.

E1 = bearings with new internal construction

Due to the new internal construction of the E1 bearings, attention must be paid to the mounting dimensions. This also applies to the configuration of the spacer sleeve on the shaft locating washer (dimensions d_b , d_{b1}) **1130**.



9
Release in the housing and maximum height of spacer sleeve

$D_{b \min}$ = minimum dimension of recess in the housing
 d_{\max} = maximum height of spacer sleeve

① Spacer sleeve

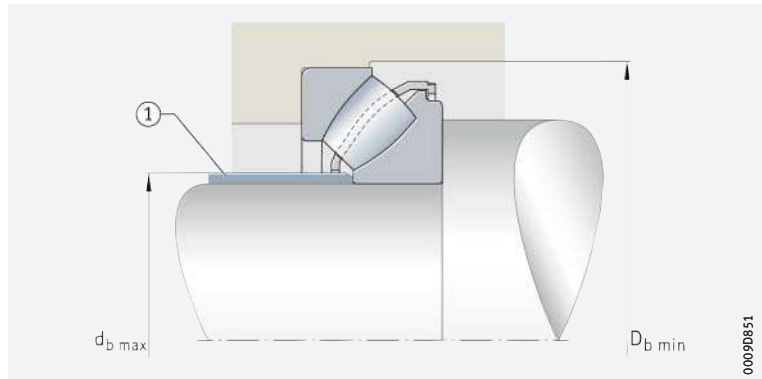

0009D851



8
Numerical values for ISO standard tolerances (IT grades) to ISO 286-1:2010

IT grade	Nominal dimension in mm						
	over	50	80	120	180	250	315
	incl.	80	120	180	250	315	400
Values in μm							
IT5	13	15	18	20	23	25	
							continued ▼



8
Numerical values for ISO standard tolerances (IT grades) to ISO 286-1:2010

IT grade	Nominal dimension in mm						
	over	400	500	630	800	1000	1250
	incl.	500	630	800	1000	1250	1600
Values in μm							
IT5	27	32	36	40	47	55	
							continued ▲

🔍 *Observe point or circumferential load of bearing washers*

Tolerances for shaft and housing bore

Fits for the bearing rings of axial spherical roller bearings, as a function of the condition of rotation ▶ 1128 | 9. The conditions of rotation for shaft and housing locating washers must be taken into consideration when defining the fits (point or circumferential load).

9
Conditions of rotation and fits

Adjacent part	Type of load	Operating conditions	Tolerance class ¹⁾
Shaft	Combined load	Point load for shaft locating washer	j6
		Circumferential load for shaft locating washer, shaft diameter up to 200 mm	j6 (k6)
		Circumferential load for shaft locating washer, shaft diameter from 200 mm	k6 (m6)
Housing	Axial load	Normal load	E8
		High load	G7
	Combined load	Point load for housing locating washer	H7
		Circumferential load for housing locating washer	K7

¹⁾ The envelope requirement © applies.



If there is any uncertainty regarding the design of adjacent parts, please consult Schaeffler.

1.17

Mounting and dismounting



🔍 *As the bearings are not self-retaining, they are easy to mount*

The mounting and dismounting options for the bearings must be taken into consideration in the design of the bearing position.

🔍 *Rolling bearings must be handled with great care*

Axial spherical roller bearings are not self-retaining. As a result, the bearing parts can be mounted separately from each other. This gives simplified mounting of the bearings.

Schaeffler Mounting Handbook

Rolling bearings are well-proven precision machine elements for the design of economical and reliable bearing arrangements, which offer high operational security. In order that these products can function correctly and achieve the envisaged operating life without detrimental effect, they must be handled with care.



The Schaeffler Mounting Handbook MH 1 gives comprehensive information about the correct storage, mounting, dismounting and maintenance of rotary rolling bearings ▶ <https://www.schaeffler.de/std/1D53>. It also provides information which should be observed by the designer, in relation to the mounting, dismounting and maintenance of bearings, in the original design of the bearing position. This book is available from Schaeffler on request.

1.18 Legal notice regarding data freshness

The further development of products may also result in technical changes to catalogue products

Of central interest to Schaeffler is the further development and optimisation of its products and the satisfaction of its customers. In order that you, as the customer, can keep yourself optimally informed about the progress that is being made here and with regard to the current technical status of the products, we publish any product changes which differ from the printed version in our electronic product catalogue.



We therefore reserve the right to make changes to the data and illustrations in this catalogue. This catalogue reflects the status at the time of printing. More recent publications released by us (as printed or digital media) will automatically precede this catalogue if they involve the same subject. Therefore, please always use our electronic product catalogue to check whether more up-to-date information or modification notices exist for your desired product.

Link to electronic product catalogue



The following link will take you to the Schaeffler electronic product catalogue: ► <https://medias.schaeffler.com>.



1.19 Further information



In addition to the data in this chapter, the following chapters in Technical principles must also be observed in the design of bearing arrangements:

- Determining the bearing size ► 34
- Rigidity ► 54
- Friction and increases in temperature ► 56
- Speeds ► 64
- Bearing data ► 97
- Lubrication ► 70
- Sealing ► 182
- Design of bearing arrangements ► 139
- Mounting and dismounting ► 191.

Axial spherical roller bearings

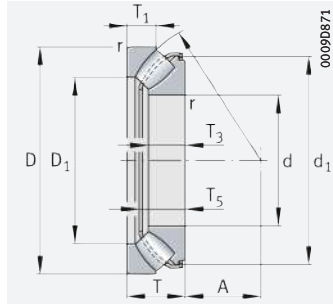

With sheet steel cage

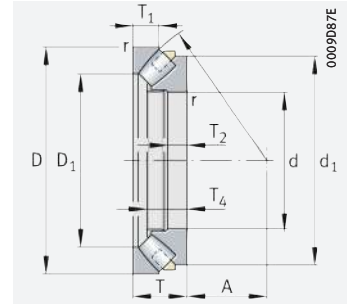

With solid brass cage

d = 60 – 190 mm

Main dimensions			Basic load ratings		Fatigue limit load	Limiting speed	Speed rating	Mass	Designation
d	D	T	dyn. C _a	stat. C _{0a}	C _{ua}	n _G	n _{Dr}	m	▶ 1124 1.12 ▶ 1125 1.13 X-life ▶ 1119
			N	N	N	min ⁻¹	min ⁻¹	≈ kg	
60	130	42	410 000	940 000	114 000	6 000	2 850	2,5	29412-E1-XL
65	140	45	495 000	1 160 000	135 000	5 500	2 600	3,1	29413-E1-XL
70	150	48	550 000	1 290 000	150 000	5 000	2 430	3,8	29414-E1-XL
75	160	51	650 000	1 540 000	174 000	4 700	2 260	4,6	29415-E1-XL
80	170	54	720 000	1 720 000	194 000	4 350	2 140	5,5	29416-E1-XL
85	150	39	420 000	1 110 000	154 000	4 850	2 260	2,7	29317-E1-XL
	180	58	800 000	1 910 000	218 000	4 100	2 010	6,5	29417-E1-XL
90	155	39	420 000	1 130 000	160 000	4 650	2 140	2,8	29318-E1-XL
	190	60	880 000	2 130 000	238 000	3 850	1 920	7,5	29418-E1-XL
100	170	42	495 000	1 340 000	189 000	4 200	1 960	3,6	29320-E1-XL
	210	67	1 060 000	2 600 000	285 000	3 400	1 740	10,1	29420-E1-XL
110	190	48	620 000	1 760 000	229 000	3 750	1 830	5,2	29322-E1-XL
	230	73	1 260 000	3 150 000	340 000	3 100	1 600	12,8	29422-E1-XL
120	210	54	800 000	2 210 000	285 000	3 350	1 700	7,2	29324-E1-XL
	250	78	1 470 000	3 700 000	390 000	2 800	1 460	15,9	29424-E1-XL
130	225	58	900 000	2 600 000	320 000	3 100	1 590	8,8	29326-E1-XL
	270	85	1 700 000	4 350 000	445 000	2 600	1 360	21	29426-E1-XL
140	240	60	1 010 000	2 900 000	355 000	2 900	1 490	10,3	29328-E1-XL
	280	85	1 720 000	4 500 000	480 000	2 460	1 290	22,1	29428-E1-XL
150	215	39	425 000	1 720 000	202 000	3 150	1 540	4,4	29230-E1-MB
	250	60	1 020 000	2 900 000	375 000	2 750	1 400	10,5	29330-E1-XL
	300	90	2 000 000	5 300 000	550 000	2 290	1 180	27,2	29430-E1-XL
160	225	39	420 000	1 720 000	212 000	3 000	1 450	4,7	29232-E1-MB
	270	67	1 220 000	3 550 000	435 000	2 500	1 320	14	29332-E1-XL
	320	95	2 240 000	6 000 000	620 000	2 120	1 090	32,1	29432-E1-XL
170	240	42	470 000	1 940 000	237 000	2 800	1 390	5,8	29234-E1-MB
	280	67	1 230 000	3 500 000	445 000	2 390	1 260	14,2	29334-E1-XL
	340	103	2 550 000	6 900 000	680 000	1 990	1 020	39,6	29434-E1-XL
180	250	42	485 000	2 070 000	250 000	2 650	1 350	6,1	29236-E1-MB
	300	73	1 460 000	4 300 000	510 000	2 240	1 170	18,4	29336-E1-XL
	360	109	2 850 000	7 700 000	750 000	1 860	940	47,6	29436-E1-XL
190	270	48	600 000	2 500 000	295 000	2 440	1 300	8,5	29238-E1-MB
	320	78	1 680 000	4 850 000	590 000	2 070	1 090	22,3	29338-E1-XL
	380	115	3 100 000	8 500 000	850 000	1 750	910	54,6	29438-E1-XL

medias ▶ <https://www.schaeffler.de/std/1E95>

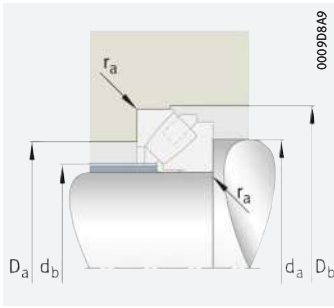

Mounting dimensions

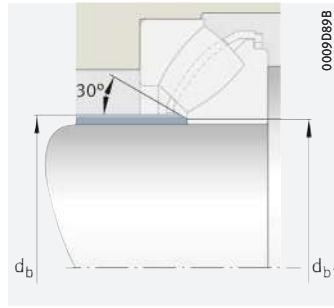

With sheet steel cage
Mounting dimensions

Dimensions

d	D ₁	d ₁	r	T ₁	T ₂	T ₃	T ₄	T ₅	A
			min.					≈	
60	85,5	116,5	1,5	21	–	27	–	37,5	38
65	91,5	125,2	2	22	–	29,5	–	40,5	42
70	99	133,8	2	23,8	–	31	–	42,5	44,8
75	105,5	142,3	2	24,5	–	33,5	–	46	47
80	112,5	150,9	2,1	26,5	–	35	–	48,5	50
85	109,5	138,5	1,5	20	–	24,5	–	34,5	50
	121	159,3	2,1	28	–	37	–	51	54
90	115	142,3	1,5	19,5	–	24,5	–	34,5	52
	127,5	167,7	2,1	28,5	–	39	–	54	56
100	127,5	156	1,5	20,5	–	26,2	–	37,5	58
	141,5	184,5	3	32	–	43	–	59,5	62
110	140	175,6	2	24,8	–	30,3	–	42	64
	155,5	201,9	3	34,7	–	47	–	64,5	69
120	154	192,6	2,1	27	–	34	–	48	70
	171	218,8	4	36,5	–	50,5	–	70	74
130	165,5	207,9	2,1	30,1	–	36,7	–	50,5	76
	184,5	240	4	40,9	–	54	–	75	81
140	177	220,6	2,1	30	–	38,5	–	53,5	82
	194,5	251,1	4	41	–	54	–	74,5	86
150	176	200	1,5	20,5	14	25	37	–	82
	190	228,4	2,1	28	–	38	–	54,5	87
	207,5	267,4	4	43,4	–	58	–	80,5	92
160	188	210	1,5	20	14	25	37	–	87
	203	248	3	33	–	42	–	59,5	92
	223,5	283,5	5	45,5	–	60,5	–	84,5	99
170	201	225	1,5	22	15	26	40	–	93
	215	255,7	3	30,5	–	42,2	–	60,5	96
	236	305	5	50	–	65,5	–	89,5	104
180	208	235	1,5	22	15	26	40	–	97
	227	274,5	3	35,5	–	46	–	64,5	103
	250	315,5	5	53	–	69,5	–	96	110
190	226	255	2	25,5	17	29	45	–	103
	243,5	290,1	4	36	–	49	–	70	110
	264,5	340	5	55,5	–	73	–	100,9	117

Mounting dimensions

d _a	D _a	D _b	d _b	d _{b1}	r _a
min.	max.	min.	max.	max.	max.
95	107	133	67	–	1,5
100	115	143	72	–	2
110	124	153	78,5	–	2
115	132	163	82,5	–	2
125	141	173	88	–	2,1
120	129	153	92	–	1,5
130	150	183	94	–	2,1
125	135	158	97	–	1,5
135	158	193	99,5	–	2,1
135	148	173	107	–	1,5
150	175	214	110,5	–	2,5
150	165	193	120	–	2
165	192	234	129	121	2,5
165	182	213	129	–	2,1
180	210	254	142	132	3
180	195	228	143	139	2,1
195	227	275	153	143	3
190	208	244	154	149	2,1
205	237	285	162	154	3
185	193	219	157	–	1,5
195	220	254	163	159	2,1
220	253	306	175	164	3
195	204	229	168	–	1,5
215	236	274	176	170	2,5
235	271	326	189	176	4
205	218	244	180	–	1,5
220	247	284	188	180	2,5
250	288	346	199	186	4
215	226	254	190	–	1,5
235	263	304	195	190	2,5
265	305	366	210	197	4
230	243	274	203	–	2
250	281	325	211	201	3
280	322	386	223	209	4





Axial spherical roller bearings

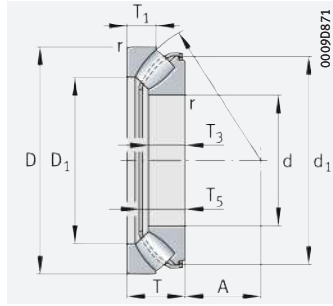

With sheet steel cage

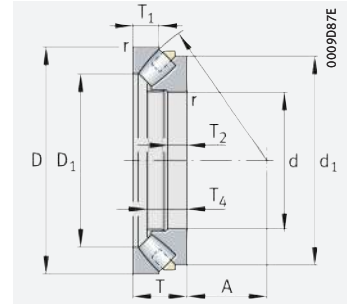

With solid brass cage

d = 200 – 380 mm

Main dimensions			Basic load ratings		Fatigue limit load	Limiting speed	Speed rating	Mass	Designation
d	D	T	dyn. C _a	stat. C _{0a}	C _{ua}	n _G	n _{Dr}	m	▶ 1124 1.12 ▶ 1125 1.13 X-life ▶ 1119
			N	N	N	min ⁻¹	min ⁻¹	≈ kg	
200	280	48	650 000	2 650 000	315 000	2 340	1 280	9	29240-E1-MB
	340	85	1 900 000	5 600 000	650 000	1 940	1 030	27,3	29340-E1-XL
	400	122	3 450 000	9 500 000	920 000	1 660	860	63,7	29440-E1-XL
220	300	48	690 000	3 000 000	350 000	2 170	1 160	9,8	29244-E1-MB
	360	85	1 990 000	6 200 000	710 000	1 820	950	30,6	29344-E1-XL
	420	122	3 500 000	10 000 000	990 000	1 560	790	69	29444-E1-XL
240	340	60	1 010 000	4 150 000	460 000	1 890	1 060	16,9	29248-E1-MB
	380	85	2 040 000	6 500 000	750 000	1 710	880	32,8	29348-E1-XL
	440	122	3 600 000	10 500 000	1 060 000	1 470	740	74,1	29448-E1-XL
260	360	60	1 040 000	4 550 000	495 000	1 780	970	17,6	29252-E1-MB
	420	95	2 550 000	8 300 000	910 000	1 540	790	45,8	29352-E1-XL
	480	132	4 400 000	13 200 000	1 280 000	1 350	660	96,6	29452-E1-XL
280	380	60	1 020 000	4 700 000	520 000	1 670	900	19	29256-E1-MB
	440	95	2 650 000	8 800 000	960 000	1 460	740	49,1	29356-E1-XL
	520	145	5 200 000	15 800 000	1 470 000	1 230	600	126	29456-E1-XL
300	420	73	1 400 000	6 200 000	650 000	1 500	830	29,9	29260-E1-MB
	480	109	3 200 000	10 500 000	1 130 000	1 320	680	65,1	29360-E1-XL
	540	145	5 200 000	16 200 000	1 510 000	1 180	570	130	29460-E1-XL
320	440	73	1 410 000	6 500 000	680 000	1 420	780	31,6	29264-E1-MB
	500	109	3 350 000	11 000 000	1 180 000	1 260	650	72,4	29364-E1-XL
	580	155	6 000 000	19 100 000	1 750 000	1 090	530	163	29464-E1-XL
340	460	73	1 410 000	6 600 000	710 000	1 350	740	33,3	29268-E1-MB
	540	122	3 750 000	12 600 000	1 320 000	1 150	600	101	29368-E1-XL-MB
	620	170	7 200 000	23 100 000	2 040 000	1 020	475	208	29468-E1-XL
360	500	85	1 870 000	8 500 000	870 000	1 230	690	49	29272-E1-MB
	560	122	3 750 000	13 000 000	1 310 000	1 110	570	105	29372-E1-XL-MB
	640	170	6 800 000	21 900 000	2 010 000	970	470	230	29472-E1-XL-MB
380	520	85	2 000 000	9 000 000	920 000	1 180	660	50,3	29276-E1-MB
	600	132	4 500 000	15 400 000	1 540 000	1 030	530	136	29376-E1-XL-MB
	670	175	7 200 000	24 200 000	2 140 000	930	445	260	29476-E1-XL-MB

medias ▶ <https://www.schaeffler.de/std/1E96>

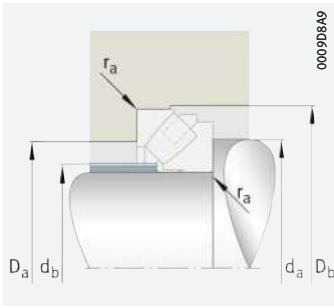

Mounting dimensions

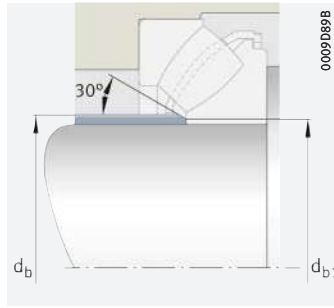

With sheet steel cage
Mounting dimensions

d	Dimensions									Mounting dimensions					
	D ₁	d ₁	r	T ₁	T ₂	T ₃	T ₄	T ₅	A	d _a	D _a	D _b	d _b	d _{b1}	r _a
	min.			≈						min.	max.	min.	max.	max.	max.
200	232,5	265	2	24	17	30	45	–	108	240	258	284	209	–	2
	257	308,8	4	40	–	53,5	–	75,5	116	265	298	348	224	213	3
	277,5	360	5	59,4	–	77	–	106,9	122	295	338	406	234	220	4
220	251,5	285	2	24,5	17	30	45	–	117	260	277	304	229	–	2
	275,5	331,8	4	41	–	55	–	75,8	125	285	316	368	240	231	3
	300	379,8	6	58,5	–	77	–	107,5	132	315	360	428	254	241	5
240	283	320	2,1	30	22	37	57	–	130	290	311	344	250	–	2,1
	295,5	350,6	4	40,5	–	54	–	76,1	135	305	337	390	259	252	3
	322	400	6	59	–	76	–	106,9	142	335	381	448	276	261	5
260	302	340	2,1	30	22	38	57	–	139	310	331	365	271	–	2
	324	387,7	5	46	–	61	–	85,2	148	340	372	430	286	275	4
	346	435	6	63	–	86	–	118,9	154	365	419	488	296	280	5
280	323	360	2,1	30	22	38	57	–	150	330	351	385	293	–	2
	343	406,5	5	45,5	–	62	–	86,1	158	355	394	450	305	293	4
	372	473,1	6	70	–	95	–	130,5	166	395	446	530	320	302	5
300	353	395	3	38	26	44	69	–	162	360	386	426	315	–	2,5
	372	439,6	5	51	–	70	–	97,9	168	385	429	490	329	318	4
	392	490	6	70	–	95	–	129,5	175	420	471	550	340	324	5
320	372	415	3	38	26	44,5	69	–	172	380	406	450	336	–	2,5
	391	460	5	53	–	68	–	96,6	180	405	449	510	347	333	4
	422	534,4	7,5	74,5	–	102	–	139,7	191	445	507	590	367	346	6
340	395	435	3	37	26	45	69	–	183	400	427	470	356	–	2,5
	428	500	5	59,5	44	75	117	–	192	440	484	550	365	–	4
	445	564,9	7,5	84	–	112	–	151,3	201	480	541	630	386	364	6
360	423	470	4	44	31	51	81	–	194,5	430	461	510	379	–	3
	448	520	5	59,5	44	75	117	–	202	455	504	572	385	–	4
	474	585	7,5	83,5	63	110	164	–	210	500	560	650	388	–	6
380	441	490	4	42	31	51,5	81	–	202	445	480	530	394	–	3
	477	555	6	63,5	48	83	127	–	216	485	538	612	404	–	5
	494	615	7,5	87,5	67	115	168	–	222	530	587	682	413	–	6

Axial spherical roller bearings

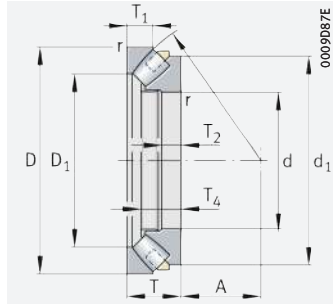

With solid brass cage

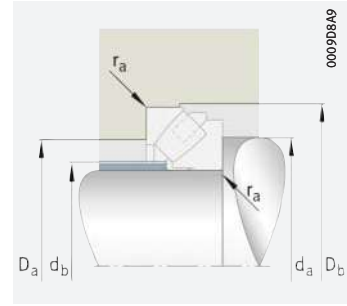

Mounting dimensions

d = 400 – 670 mm

Main dimensions			Basic load ratings		Fatigue limit load	Limiting speed	Speed rating	Mass	Designation
d	D	T	dyn. Ca	stat. C0a	Cua	nG	nθr	m	▶ 1124 1.12 ▶ 1125 1.13 X-life ▶ 1119
			N	N	N	min ⁻¹	min ⁻¹	≈ kg	
400	540	85	2 040 000	9 600 000	970 000	1 130	620	52,6	29280-E1-MB
	620	132	4 550 000	16 300 000	1 640 000	990	500	142	29380-E1-XL-MB
	710	185	8 200 000	26 500 000	2 390 000	870	425	308	29480-E1-XL-MB
420	580	95	2 460 000	11 100 000	1 110 000	1 040	600	70,3	29284-E1-MB
	650	140	5 000 000	17 500 000	1 650 000	940	480	163	29384-E1-XL-MB
	730	185	8 200 000	28 500 000	2 490 000	840	395	325	29484-E1-XL-MB
440	600	95	2 500 000	12 400 000	1 170 000	1 010	560	77,1	29288-E1-MB
	680	145	5 200 000	18 300 000	1 660 000	890	470	185	29388-E1-XL-MB
	780	206	9 700 000	32 500 000	2 850 000	780	375	418	29488-E1-XL-MB
460	620	95	2 550 000	12 200 000	1 210 000	970	540	77,6	29292-E1-MB
	710	150	5 900 000	21 400 000	2 060 000	850	430	207	29392-E1-XL-MB
	800	206	9 800 000	33 500 000	2 950 000	760	360	435	29492-E1-XL-MB
480	650	103	2 650 000	13 700 000	1 300 000	920	520	97,5	29296-E1-MB
	730	150	5 800 000	21 400 000	1 940 000	820	415	219	29396-E1-XL-MB
	850	224	11 700 000	39 500 000	3 350 000	710	335	531	29496-E1-XL-MB
500	670	103	2 750 000	14 700 000	1 370 000	890	495	102	292/500-E1-MB
	750	150	5 900 000	22 000 000	1 950 000	800	400	228	293/500-E1-XL-MB
	870	224	11 600 000	40 000 000	3 450 000	690	325	551	294/500-E1-XL-MB
530	710	109	3 000 000	15 400 000	1 480 000	830	475	120	292/530-E1-MB
	800	160	6 800 000	25 500 000	2 280 000	740	375	274	293/530-E1-XL-MB
	920	236	12 700 000	44 500 000	3 750 000	650	305	653	294/530-E1-XL-MB
560	750	115	3 450 000	18 100 000	1 670 000	790	440	142	292/560-E1-MB
	980	250	14 600 000	51 000 000	4 200 000	610	285	783	294/560-E1-XL-MB
600	800	122	3 650 000	19 400 000	1 810 000	730	415	167	292/600-E1-MB
	900	180	8 700 000	34 000 000	2 950 000	660	325	392	293/600-E1-XL-MB
	1 030	258	15 200 000	56 000 000	4 550 000	580	265	889	294/600-E1-XL-MB
630	850	132	4 650 000	23 600 000	2 140 000	690	390	208	292/630-E1-MB
	950	190	9 700 000	37 500 000	3 250 000	620	305	462	293/630-E1-XL-MB
	1 090	280	17 300 000	62 000 000	5 100 000	540	250	1 073	294/630-E1-XL-MB
670	900	140	4 750 000	24 900 000	2 250 000	640	370	247	292/670-E1-MB
	1 000	200	10 600 000	41 000 000	3 350 000	580	285	526	293/670-E1-XL-MB
	1 150	290	18 400 000	66 000 000	5 400 000	510	241	1 214	294/670-E1-XL-MB

medias ▶ <https://www.schaeffler.de/std/1E97>



Dimensions									Mounting dimensions				
d	D ₁	d ₁	r	T ₁	T ₂	T ₃	T ₄	A	d _a	D _a	D _b	d _b	r _a
			min.						min.	max.	min.	max.	max.
400	460	510	4	42	31	53,5	81	212	465	500	550	414	3
	494	575	6	64	48	83	127	225	510	557	634	429	5
	525	650	7,5	89,5	69	120	178	234	555	622	722	434	6
420	489	545	5	46	34	58,5	91	225	495	534	590	439	4
	520	600	6	67,5	50	85	135	235	530	585	664	449	5
	545	670	7,5	90,5	70	124	178	244	580	643	742	457	6
440	508	570	5	49	34	61	91	235	520	554	610	458	4
	540	631,5	6	70,5	52	87	140	245	555	614	695	473	5
	577	715	9,5	101	77	134	199	257	610	684	794	477	8
460	530	585	5	46	34	59	91	245	535	575	632	479	4
	567	660	6	72,5	54	94,5	144	257	585	638	726	491	5
	596	735	9,5	101,5	77	135	199	268	630	704	815	497	8
480	556	620	5	55	37	62	99	259	565	603	662	507	4
	591	680	6	73,5	54	94	144	270	605	660	746	511	5
	625	780	9,5	108	88	147	216	280	660	744	865	516	8
500	574	640	5	55	37	65	99	268	585	622	682	524	4
	611	700	6	74	54	92	144	280	625	683	768	534	5
	648	800	9,5	110	86,6	147	216	290	685	765	886	539	8
530	608	675	5	57	39	64	105	285	620	661	722	561	4
	648	745	7,5	76	58	101,5	154	295	660	724	818	564	6
	686	845	9,5	116	89	156	228	308	725	810	937	570	8
560	644	715	5	60	41	71	111	302	655	697	762	587	4
	727	900	12	122	99	168	241	328	770	860	997	602	10
600	688	760	5	65	44	71,5	117	321	700	744	814	634	4
	720	840	7,5	89	65	113,5	174	335	745	815	920	634	6
	769	950	12	128	99	172	249	349	820	900	1055	649	10
630	723	805	6	67	48	80	127	338	735	789	864	658	5
	761	885,5	9,5	92	68	122	183	345	785	856	970	666	8
	815	1000	12	137	107	183	270	365	860	960	1115	678	10
670	773	855	6	74	50	81	135	361	785	836	915	707	5
	809	930	9,5	96	72	126	193	372	825	906	1020	703	8
	864	1060	15	141	110	191	280	387	910	1015	1175	723	12



Axial spherical roller bearings

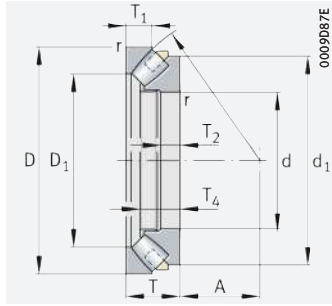

With solid brass cage

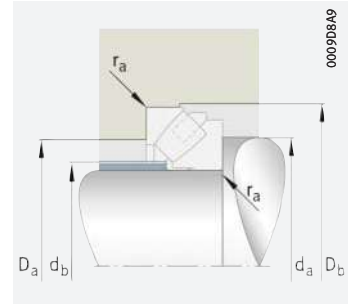

Mounting dimensions

d = 710 – 1 600 mm

Main dimensions			Basic load ratings		Fatigue limit load C_{ua}	Limiting speed n_G	Speed rating $n_{\theta r}$	Mass m	Designation
d	D	T	dyn. C_a	stat. C_{0a}					
			N	N	N	min^{-1}	min^{-1}	≈ kg	
710	950	145	5 500 000	29 500 000	2 550 000	610	335	281	292/710-E1-MB
	1 060	212	11 800 000	46 000 000	3 700 000	550	265	635	293/710-E1-XL-MB
	1 220	308	21 000 000	76 000 000	6 100 000	475	220	1 469	294/710-E1-XL-MB
750	1 000	150	5 700 000	31 500 000	2 750 000	570	320	326	292/750-E1-MB
	1 120	224	12 700 000	50 000 000	3 850 000	510	250	735	293/750-E1-XL-MB
	1 280	315	19 000 000	84 000 000	6 600 000	455	206	1 654	294/750-E1-MB
800	1 060	155	6 400 000	35 500 000	3 050 000	540	300	365	292/800-E1-MB
	1 180	230	13 500 000	54 000 000	4 050 000	485	237	824	293/800-E1-XL-MB
	1 360	335	20 600 000	93 000 000	7 400 000	425	191	1 964	294/800-E1-MB
850	1 120	160	7 100 000	40 500 000	3 400 000	510	275	422	292/850-E1-MB
	1 250	243	12 900 000	62 000 000	4 600 000	455	218	972	293/850-E1-MB
	1 440	354	24 000 000	110 000 000	8 400 000	400	174	2 348	294/850-E1-MB
900	1 180	170	7 700 000	42 000 000	3 250 000	475	265	478	292/900-E1-MB
	1 520	372	25 500 000	120 000 000	8 900 000	375	166	2 744	294/900-E1-MB
950	1 250	180	8 800 000	48 500 000	3 900 000	445	248	577	292/950-E1-MB
	1 600	390	28 500 000	132 000 000	9 900 000	355	155	3 170	294/950-E1-MB
1 000	1 320	190	9 600 000	55 000 000	4 450 000	420	233	689	292/1000-E1-MB
	1 670	402	30 500 000	146 000 000	10 600 000	340	145	3 575	294/1000-E1-MB
1 060	1 400	206	10 700 000	62 000 000	4 850 000	395	219	852	292/1060-E1-MB
	1 770	426	33 000 000	155 000 000	11 600 000	315	139	4 201	294/1060-E1-MB
1 120	1 460	206	10 700 000	64 000 000	4 650 000	375	207	896	292/1120-E1-MB
1 180	1 520	206	10 700 000	67 000 000	4 750 000	360	196	945	292/1180-E1-MB
1 250	1 800	330	23 700 000	125 000 000	8 100 000	305	142	2 654	293/1250-E1-MB
1 600	2 280	408	36 000 000	192 000 000	10 900 000	233	107	5 137	293/1600-E1-MB

medias ► <https://www.schaeffler.de/std/1E98>



Dimensions										Mounting dimensions				
d	D ₁	d ₁	r	T ₁	T ₂	T ₃	T ₄	A	d _a	D _a	D _b	d _b	r _a	
			min.											min.
710	815	900	6	75	52	88	140	380	825	882	966	741	5	
	855	985	9,5	103	76	132,5	205	394	875	962	1 082	746	8	
	917	1 120	15	149	117	202	298	415	960	1 073	1 250	762	12	
750	858	950	6	81	54	89	144	409	875	930	1 017	789	5	
	910	1 040	9,5	109	81	140	216	415	925	1 015	1 142	790	8	
	964	1 180	15	153	121	210	305	436	1 015	1 130	1 310	811	12	
800	911	1 010	7,5	81	56	94	149	434	925	987	1 078	837	6	
	965	1 100	9,5	111	83	145,5	222	440	980	1 070	1 202	840	8	
	1 034	1 255	15	165	123	219	324	462	1 085	1 200	1 390	870	12	
850	967	1 070	7,5	82	58	101,5	154	455	985	1 043	1 138	886	6	
	1 021	1 165	12	118	87	152	235	468	1 045	1 137	1 273	896	10	
	1 077	1 325	15	172	142,9	239	342	490	1 145	1 275	1 470	915	12	
900	1 023	1 120	7,5	84	61	102,5	167	477	1 025	1 089	1 198	933	6	
	1 137	1 405	15	186	147	251	360	518	1 215	1 345	1 555	969	12	
950	1 081	1 190	7,5	90	65	110	174	507	1 090	1 147	1 268	985	6	
	1 209	1 475	15	191	153	260	377	546	1 275	1 372	1 635	1 020	12	
1 000	1 139	1 255	9,5	98	68	117,5	182	540	1 155	1 216	1 340	1 042	8	
	1 250	1 540	15	200	160	277	390	581	1 340	1 435	1 705	1 071	12	
1 060	1 211	1 336,3	9,5	108	74	124	199	566	1 225	1 290	1 422	1 106	8	
	1 349	1 630	15	207	192	280	412	610	1 410	1 521	1 815	1 141	12	
1 120	1 272	1 395	9,5	108	74	125	199	601	1 285	1 350	1 482	1 168	8	
1 180	1 331	1 455	9,5	108	74	125	199	625	1 345	1 415	1 542	1 227	8	
1 250	1 465	1 690,5	15	161	119	208	319	690	1 515	1 640	1 823	1 315	12	
1 600	1 885	2 135,5	19	195	147	255	395	894	1 915	2 090	2 303	1 675	15	

Crossed roller bearings



Matrix for bearing preselection 1141

1 Crossed roller bearings 1142

- 1.1 Bearing design 1142
- 1.2 Load carrying capacity 1143
- 1.3 Angular adjustment facility 1144
- 1.4 Lubrication 1144
- 1.5 Sealing 1145
- 1.6 Speeds 1146



1.7	Noise	1146	1.17	Mounting and dismounting	1163
1.8	Temperature range	1146	1.18	Legal notice regarding data freshness	1166
1.9	Cages	1147	1.19	Further information	1166
1.10	Internal clearance	1147	Product tables	1168	
1.11	Dimensions, tolerances	1147	 Crossed roller bearings	1168	
1.12	Suffixes	1147			
1.13	Structure of bearing designation	1147			
1.14	Dimensioning	1148			
1.15	Minimum load	1158			
1.16	Design of bearing arrangements	1158			





























Matrix for bearing preselection

The matrix gives an overview of the types and design features of crossed roller bearings.

It can be used to make a preliminary assessment of whether a bearing is fundamentally suitable for the envisaged application.

The additional information provided in the product chapter (see column "detailed information") and in the Technical principles must, however, be observed in selection of the bearing.

Design features and suitability			Crossed roller bearings	
+++ extremely suitable ++ highly suitable + suitable (+) suitable with restrictions – not suitable/not applicable ✓ available			 ▶ 1142 detailed information	
Load carrying capacity	radial		++	▶ 1143 1.2
	axial, one direction		+++	▶ 1143 1.2
	axial, both directions		+++	▶ 1143 1.2
	moments		++	▶ 1143 1.2
Compensation of angular misalignments	static		–	▶ 1144 1.3
	dynamic		–	▶ 1144 1.3
Bearing design	cylindrical bore		–	▶ 1142 1.1
	tapered bore		–	
	separable		–	▶ 1163 1.17
Lubrication	greased		✓	▶ 1144 1.4
Sealing	open		✓	▶ 1145 1.5
	non-contact		–	▶ 1145 1.5
	contact		–	▶ 1145 1.5
Operating temperature in °C		from to 	–30 +100	▶ 1146 1.8
Suitability for	high speeds		(+)	▶ 1146 1.6
	high running accuracy		++	▶ 1150 ▶ 1147 1.11
	low-noise running		+	▶ 1146 1.7
	high rigidity		+	▶ 1150
	reduced friction		+	▶ 56
	length compensation within bearing		–	
	non-locating bearing arrangement		–	▶ 139
	locating bearing arrangement		+	▶ 139
X-life bearings		X-life	–	
Bearing bore d_i in mm		from to 	70 500	▶ 1168
Product tables			from page 	1168



1 Crossed roller bearings



Crossed roller bearings SX:

- are suitable, due to their high running accuracy, as bearings for high precision applications (such as those in robots, machine tools, handling systems, precision mechanical and medical devices, vehicle components)
- correspond in their main dimensions to the ISO dimension series 18 with very small section height
- can support axial forces in both directions, radial loads, tilting moments and any combination of loads ▶ 1143 | 1.2
- usually allow designs with two bearing positions to be replaced by one bearing position ▶ 1142 | 1
- are very rigid (they can be supplied with normal clearance, clearance-free or preloaded) ▶ 1168 | 3
- are suitable for compressive and suspended arrangements
- are always a good choice for a technically and economically leading bearing solution if compact and easy-to-fit rolling bearings with high tilting moment carrying capacity and rigidity, with uniform running free from stick-slip, low rotational resistance as well as high axial and radial runout accuracy are required in only one bearing position.

For an overview of other product-specific features, see the Matrix for bearing preselection ▶ 1141.

1
Comparison:
bearing arrangement
with two bearing positions/
bearing arrangement
with a crossed roller bearing SX

- ① Bearing arrangement with two bearing positions
- ② Bearing arrangement with one crossed roller bearing SX

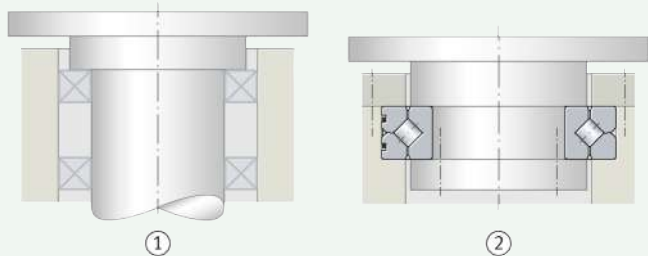

1.1 Bearing design

ⓘ **Crossed roller bearings SX are compact locating bearings with high axial rigidity**

Crossed roller bearings SX are bearings for high precision applications, whose main dimensions correspond to the ISO dimension series 18 with very small section height in accordance with DIN 616. They comprise outer rings, inner rings, rolling elements and plastic spacers. The outer ring is split in the circumferential direction and is held together by three sheet metal retaining rings ▶ 1143 | 2. The cylindrical rollers correspond to DIN 5402 and are in an X arrangement with each other on the raceways. The bearings are very rigid, have high running accuracy and are supplied with normal clearance, low clearance or preload. Bearings with preload have the suffix VSP, while bearings with low clearance have the suffix RL0 ▶ 1147 | 3. The bearing outer rings are easily fixed to the adjacent construction using clamping rings ▶ 1159.

Also available in a corrosion-resistant design

For applications requiring high corrosion protection, the bearings are also available in a corrosion-resistant design with the special coating Corroprotect ▶ 109.

2
Crossed roller bearing SX

- ① Split outer ring
- ② Sheet metal retaining ring
- ③ Lubrication hole (3 lubrication holes distributed over the circumference)
- ④ Plastic spacers



1
Influencing factors

Permissible circumferential velocities

The possible circumferential velocity is dependent on the bearing (normal clearance or preloaded) and on the lubrication (grease or oil) ▶ 1143 | 1.

1
Permissible circumferential velocities

D_M = rolling element pitch circle diameter ▶ 1168 | 1

Normal clearance	Preload	Circumferential velocity
Oil lubrication	–	up to 8 m/s ($n \cdot D_M = 152\,800$)
Grease lubrication	–	up to 4 m/s ($n \cdot D_M = 76\,400$)
–	Oil lubrication	up to 4 m/s ($n \cdot D_M = 76\,400$)
–	Grease lubrication	up to 2 m/s ($n \cdot D_M = 38\,200$)

1.2 Load carrying capacity

Suitable for axial loads in both directions, radial loads and tilting moment loads

Due to the X arrangement of the cylindrical rollers, the bearings can support axial forces in both directions, radial loads, tilting moment loads and any combination of loads by means of a single bearing position ▶ 1144 | 4. As a result, it is generally possible to reduce conventional bearing arrangements comprising two bearing positions (bearing arrangement with one radial and one axial bearing) to one bearing position ▶ 1144 | 3 and ▶ 1144 | 4. This reduces the work required and the costs for the design of the adjacent construction (only one bearing position is processed) and considerably reduces the mounting of the bearings (there is no requirement for the matching of two bearings to each other).

3

Conventional bearing arrangement with two bearing positions

F_r = radial load
 F_a = axial load
 M = tilting moment load

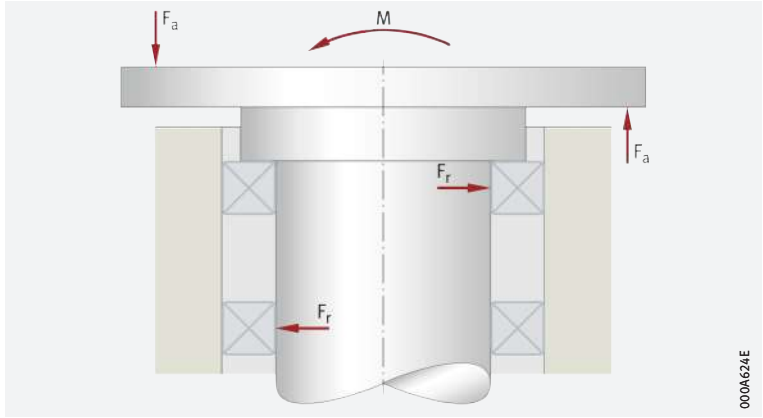

000A624E

4

Optimised bearing arrangement with one crossed roller bearing

F_r = radial load
 F_a = axial load
 M = tilting moment load

① Crossed roller bearing SX

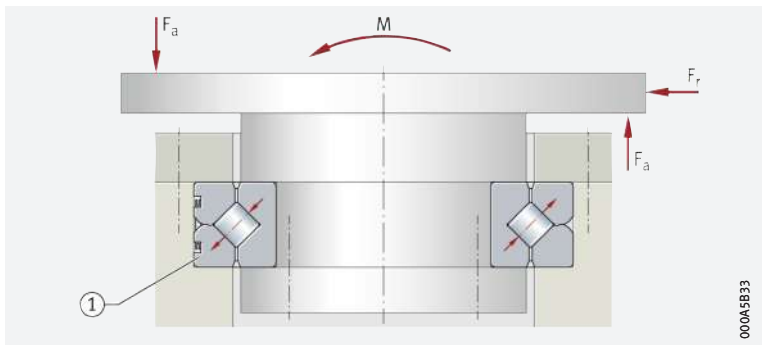

000A5B33

1.3 Angular adjustment facility



Crossed roller bearings SX cannot be used for the compensation of misalignments. These bearings are precision bearings for high precision applications. In order to ensure their correct function, it is essential that the specifications for design of the adjacent construction are observed ► 1158| 1.16. Skewing of the bearing rings increases the running noise, places increased strain on the plastic spacers, has a negative effect on the running accuracy and a highly detrimental influence on the operating life of the bearings.

1.4 Lubrication

☞ Grease or oil lubrication is possible

The bearings are greased as standard but can alternatively be lubricated with oil. The decisive factors in determining the type of lubrication and the requisite lubricant quantity are:

- the size of the bearing
- the design of the bearing environment
- the lubricant feeds
- the operating conditions.



If there is any uncertainty as to whether the lubricant or type of lubrication is suitable for a particular application, please consult Schaeffler or the lubricant manufacturer respectively.

Grease lubrication

☞ Suitable greases

If the bearing is to be lubricated with grease, a high quality lithium soap grease to DIN 51825-KP2N-20 is suitable, for example Arcanol LOAD150 or LOAD220.

Influences on the lubrication interval

Lubrication intervals

The lubrication intervals are essentially dependent on:

- the operating conditions
- the environmental influences such as contamination, water, etc.
- the type of bearings.

Precise lubrication intervals can only be determined by means of tests under the specific application conditions. The observation period selected must be sufficiently long and the condition of the grease must be checked at regular intervals.

Grease operating life

If relubrication is not possible, the grease operating life becomes the decisive factor. Based on experience, the guide value for the grease operating life in the majority of applications is higher by a factor of 2 than the guide value for the lubrication interval. At operating temperatures above +70 °C, the lubrication interval and therefore the grease operating life are reduced. In order to ensure operational reliability, the grease operating life should not exceed 3 years.

Oil lubrication

Selection of the oil

A lubricant film which is capable of supporting loads must form in the contact zones between the rolling elements and the raceway. Depending on the operating speed, the oil at operating temperature must have at least the nominal viscosity ν_1 . The guide value for ν_1 is dependent on the mean bearing diameter d_M and the speed.



Influence of temperature on viscosity

As the temperature increases, the viscosity of the oil decreases. When selecting the viscosity, the lower operating temperature must also be taken into consideration. With increasing viscosity, the flowability of the lubricant is reduced. As a result, the level of power losses will increase.

Suitable oils

For oil lubrication, suitable oils are type CLP to DIN 1517 or HLP to DIN 51524 of the viscosity classes ISO VG 10 to 100.

With oil lubrication, oil change intervals must be observed

At higher temperatures, aged oil and additives in the oil can impair the operating life of the plastic used for the spacers. Stipulated oil change intervals must therefore be observed.

1.5 Sealing

Provide seals in the adjacent construction

Crossed roller bearings SX are not sealed. As a result, sealing of the bearing position must be carried out in the adjacent construction. This must reliably prevent:

- moisture and contaminants from entering the bearing
- the egress of lubricant from the bearing.

Schaeffler seal profiles

Material by the metre for radial and/or axial sealing of the bearing position

For sealing of the bearing position in the adjacent construction, Schaeffler supplies various seal profiles by the metre ► 1146 |  5. These profiles are intended for axial and/or radial sealing and – depending on the seal profile – fulfil a wide range of requirements (for example: under normal requirements for sealing, under heavy contamination, for low frictional torque, if only limited space is available, for sealing of fluids, at low speeds or under swivel operation). In addition to the seal profiles with a radial or axial sealing effect respectively, double direction profiles (with both axial and radial sealing effect) are also available. Mounting drawings can be requested for the individual seal profiles.



The seal profiles are not suitable for applications that require leakage-free operation; this applies not only to oil but also to grease lubrication. If leakage losses are unacceptable, measures such as rotary shaft seals can be used. The area around the bearing seal must be designed such that the seal profiles are not damaged during operation.

5
Seal profiles – example

- ① Axial sealing
- ② Radial sealing

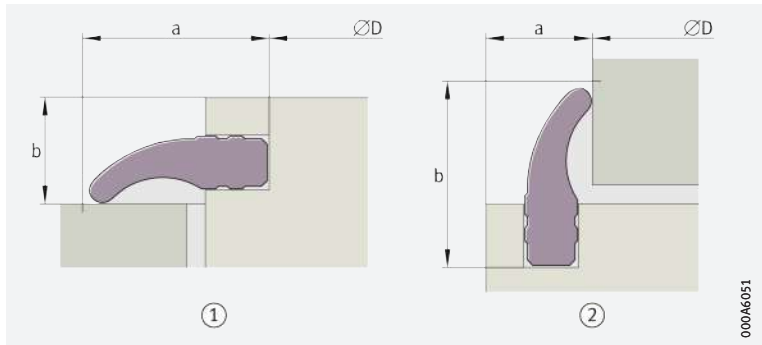

Seal profile material

The standard material for the profiles is the synthetic elastomer NBR 70. This material has good resistance to oil and grease as well as good wear resistance. Operating temperature of seal profiles > 1146 | 2. For further information on the seal profiles, please contact Schaeffler.



1.6 Speeds

Limiting speeds in the product tables

Rolling bearings cannot rotate at unspecified high speeds, but are generally restricted by the operating temperature that is permissible in relation to the lubricant and the material of the bearing parts > 1146 | 1.8. The product tables give the kinematic limiting speeds n_G oil and n_G grease for the bearings > 1168 | 2.



The limiting speeds n_G oil and n_G grease are the kinematically permissible speeds for a bearing and apply to oil and grease lubrication respectively. Even under favourable mounting and operating conditions, these speeds must not be exceeded without prior consultation with Schaeffler.

1.7 Noise

Schaeffler Noise Index

The Schaeffler Noise Index (SGI) is not yet available for this bearing type > 69. The data for these bearing series will be introduced and updated in stages.

Further information:

■ **medias** > <https://medias.schaeffler.com>.

1.8 Temperature range

Limiting values

The operating temperature of the bearings is limited by:

- the dimensional stability of the bearing rings and cylindrical rollers
- the material of the plastic spacers
- the lubricant
- the seal material in the adjacent construction.

Possible operating temperatures of the bearings > 1146 | 2.

2
Permissible temperature ranges

Operating temperature	Crossed roller bearings	Schaeffler seal profiles
	-30 °C to +100 °C	-40 °C to +80 °C



In the event of anticipated temperatures which lie outside the stated values, please contact Schaeffler.

1.9 Cages

The rollers are guided by plastic spacers

In the crossed roller bearings SX, the rolling elements are separated from each other and guided not by typical rolling bearing cages but by plastic spacers ▶ 1143 | 2. The plastic selected and the design of the running surfaces for the cylindrical rollers give low-friction running of the bearings.

1.10 Internal clearance

The crossed roller bearings are available:

- with normal clearance (radial and axial clearance ▶ 1168 | 3)
- with low clearance (radial clearance/preload ▶ 1168 | 3)
- with preload VSP (preload min. and max. ▶ 1168 | 3).

1.11 Dimensions, tolerances

Dimension standards



The main dimensions of crossed roller bearings correspond to dimension series 18 in accordance with DIN 616.

Tolerances



The dimensional and running tolerances are based on DIN 620-2 and DIN 620-3 and are in the range P6 and P5.



1.12 Suffixes

For a description of the suffixes used in this chapter ▶ 1147 | 3 and **medias** interchange ▶ <https://www.schaeffler.de/std/1D52>.

3
Suffixes and corresponding descriptions

Suffix	Description of suffix	
RR	Corrosion-resistant design, with Corrotect coating	Special design, available by agreement
RLO	Low clearance	Standard
VSP	Preloaded	Special design, available by agreement
VSP+PRL50	Preloaded, axial and radial runout tolerance restricted by 50%	Special design, available by agreement

1.13 Structure of bearing designation

Example of composition of bearing designation

6
Crossed roller bearing SX, preloaded, corrosion-resistant (with Corrotect coating): designation structure

The designation of bearings follows a set model. Example ▶ 1147 | 6.



1.14 Dimensioning

Static load carrying capacity

For bearings under static loading, the static load carrying capacity applies

Crossed roller bearings that undergo rotary motion only infrequently, undergo slow swivel motion, rotate only slowly or are subjected to load while stationary are dimensioned on the basis of their static load carrying capacity. The size of a statically loaded bearing can therefore be checked in approximate terms using the basic static load ratings C_0 and the static limiting load diagrams.

Checking the static load carrying capacity

It can be checked in approximate terms if the correct load arrangement is present and all the requirements relating to clamping rings, location, mounting and lubrication are fulfilled ▶ 1148 | 7.



Where load arrangements are more complex or there are variations from the conditions, please contact us.

7
Load arrangement

- F_{0a} = axial static bearing load
- F_{0r} = radial static bearing load
- M_{0k} = static tilting moment load

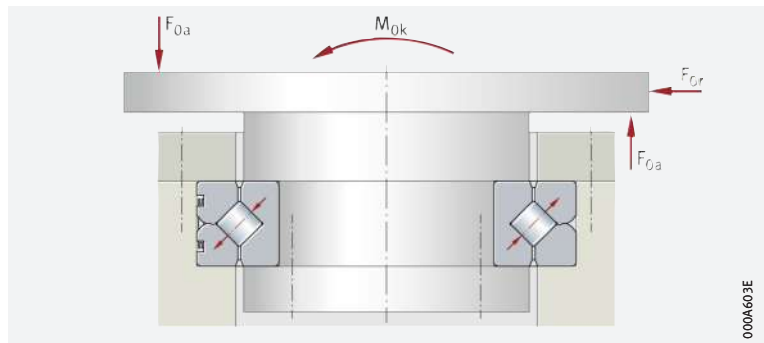

In order to check the static load carrying capacity, the following equivalent static operating values must be determined:

- the equivalent static bearing load F_{0q}
- the equivalent static tilting moment load M_{0q} .

Checking is possible for applications with or without radial load.

Determining the equivalent static bearing load without radial load

In the presence of axial and tilting moment loads only ▶ 1148 | f1 and ▶ 1148 | f2:

f1
Equivalent axial bearing load (static)

$$F_{0q} \triangleq F_{0a} \cdot f_A \cdot f_S$$

f2
Equivalent tilting moment load (static)

$$M_{0q} \triangleq M_{0k} \cdot f_A \cdot f_S$$

Legend

F_{0q}	kN	Equivalent axial bearing load (static)
F_{0a}	kN	Axial static bearing load
f_A	-	Application factor ▶ 1150 4
f_S	-	Factor for additional safety ▶ 1150
M_{0q}	kNm	Equivalent tilting moment load (static)
M_{0k}	kNm	Static tilting moment load.

The values for F_{0q} and M_{0q} are used to determine the load point in the static limiting load diagram for the raceway ▶ 1168 | 4.

In addition to the raceway, the dimensioning of the fixing screws must also be checked.









The static limiting load diagrams for the raceway and the fixing screws are indicated in the product tables.



The load point must lie under the raceway curve, otherwise the bearing is not adequately dimensioned.

Determining the equivalent static bearing load with radial load

! Radial loads can only be taken into consideration if the radial load F_{Or} is smaller than the basic static radial load rating $C_{Or} > 1168$ .
The equivalent static bearing load with radial load is determined as follows:

- Calculate the parameter for the load eccentricity ϵ according to [▶ 1149](#)  3
- Determine the static radial load factor f_{Or} . In this case:
 - determine the ratio F_{Or}/F_{0a} in [▶ 1149](#)  8 or [▶ 1150](#)  9 respectively
 - based on the ratio F_{Or}/F_{0a} and ϵ , determine the static radial load factor f_{Or} from [▶ 1149](#)  8 or [▶ 1150](#)  9 respectively
- Determine the application factor f_A [▶ 1150](#)  4 and, where necessary, the safety factor f_S
- Calculate the equivalent axial bearing load F_{0q} and the equivalent tilting moment load M_{0q} using the equations [▶ 1149](#)  4 and [▶ 1149](#)  5
- Using the values for F_{0q} and M_{0q} , determine the load point in the static limiting load diagram for the raceway [▶ 1168](#) .

! The load point must lie under the raceway curve, otherwise the bearing is not adequately dimensioned.

 3
Load eccentricity parameter

$$\epsilon = \frac{2\,000 \cdot M_{0k}}{F_{0a} \cdot D_M}$$





 4
Equivalent bearing load (static)

$$F_{0q} = F_{0a} \cdot f_A \cdot f_S \cdot f_{Or}$$

 5
Equivalent tilting moment load (static)

$$M_{0q} = M_{0k} \cdot f_A \cdot f_S \cdot f_{Or}$$

Legend

ϵ	–	Load eccentricity parameter
M_{0k}	kNm	Static tilting moment load
F_{0a}	kN	Axial static bearing load
D_M	mm	Rolling element pitch circle diameter ▶ 1168 
F_{0q}	kN	Equivalent bearing load (static)
f_A	–	Application factor ▶ 1150  4
f_S	–	Factor for additional safety ▶ 1150
f_{Or}	–	Static radial load factor ▶ 1149  8 or ▶ 1150  9
M_{0q}	kNm	Equivalent tilting moment load (static).

 8
Static radial load factor

f_{Or} = static radial load factor
 ϵ = load eccentricity parameter;
 $\epsilon \leq 2$
 F_{0a} = axial static bearing load
 F_{Or} = radial static bearing load

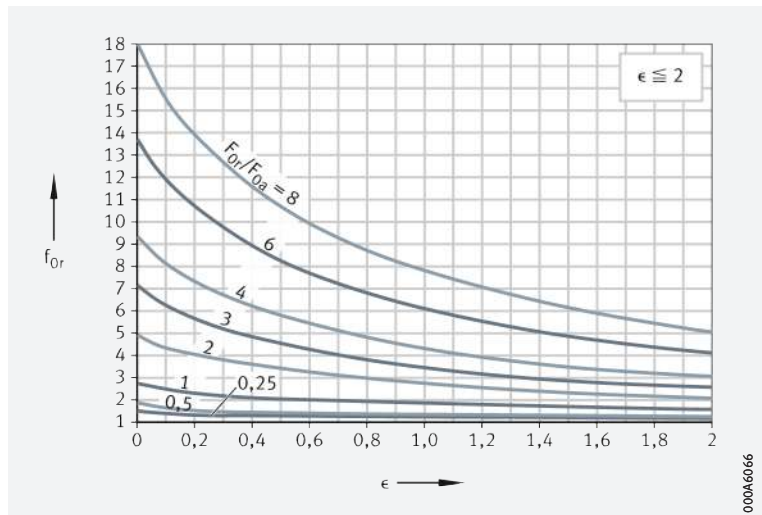

9

Static radial load factor

- f_{Or} = static radial load factor
- ϵ = load eccentricity parameter;
 $\epsilon > 2$
- F_{0a} = axial static bearing load
- F_{Or} = radial static bearing load

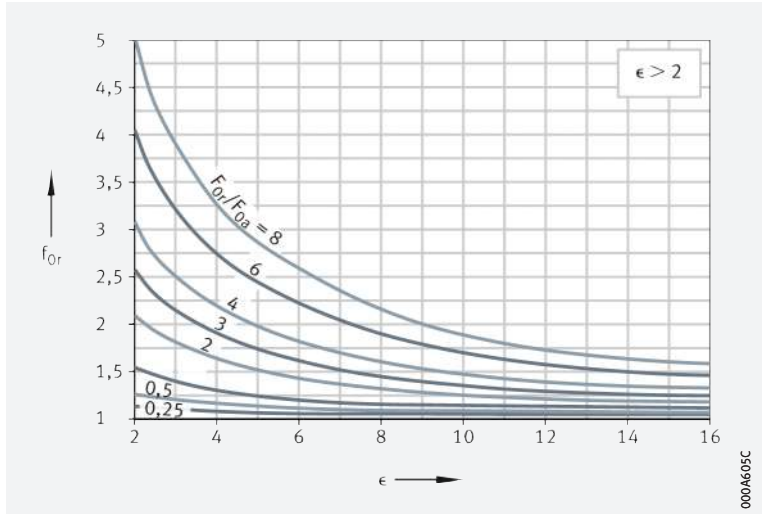

Application factors

The application factors f_A are empirical values obtained in practice ▶ 1150 | 4. They take account of the most important requirements, such as the type and severity of operation, rigidity and running accuracy. If the precise requirements of an application are known, the values may be altered accordingly.



Application factors < 1 must not be used.

A large proportion of applications can be statically calculated using the factor 1, for example in the case of bearings for gearboxes and rotary tables.

In addition to static calculation, the rating life should also always be checked ▶ 1152.

4

Application factors f_A

Application	Operating and requirement criteria	Application factor f_A
Robots	Rigidity	1,25
Antennae	Accuracy	1,5
Machine tools	Accuracy	1,5
Metrology	Smooth running	2
Medical equipment	Smooth running	1,5

Safety factors

The factor for additional safety f_S is 1.



It is not normally necessary to factor in any additional safety in calculation. In special cases, such as approval specifications, internal specifications, requirements stipulated by inspection bodies etc., the appropriate safety factors must be applied.

Calculation example

The static load carrying capacity of the crossed roller bearing SX011860 is to be checked.

Given

- Static bearing load (axial) $F_{0a} = 70 \text{ kN}$
- Static bearing load (radial) $F_{Or} = 17,5 \text{ kN}$
- Static tilting moment load $M_{Ok} = 22,5 \text{ kNm}$
- Rolling element pitch circle diameter $D_M = 340 \text{ mm}$
- Application factor $f_A = 1,25$
- Safety factor $f_S = 1$

Required

Static load carrying capacity of the bearing

f 6

Load eccentricity parameter

$$\epsilon = \frac{2\,000 \cdot M_{0k}}{F_{0a} \cdot D_M}$$



$$\epsilon = \frac{2\,000 \cdot 22,5}{70 \cdot 340} = 1,89$$

$$\frac{F_{0r}}{F_{0a}} = \frac{17,5}{70} = 0,25$$

$$f_{0r} = 1,2$$

Legend

ϵ	-	Load eccentricity parameter
M_{0k}	kNm	Static tilting moment load
F_{0a}	kN	Static bearing load (axial)
D_M	mm	Rolling element pitch circle diameter
F_{0r}	kN	Static bearing load (radial)
f_{0r}	-	Static radial load factor ► 1149 ☐ 8 or ► 1150 ☐ 9.

f 7

Equivalent bearing load (static)

$$F_{0q} = F_{0a} \cdot f_A \cdot f_S \cdot f_{0r}$$



$$F_{0q} = 70 \cdot 1,25 \cdot 1 \cdot 1,2 = 105 \text{ kN}$$

Legend

F_{0q}	kN	Equivalent bearing load (static)
F_{0a}	kN	Static bearing load (axial)
f_A	-	Application factor
f_S	-	Factor for additional safety.

f 8

Equivalent tilting moment load (static)

$$M_{0q} = M_{0k} \cdot f_A \cdot f_S \cdot f_{0r}$$



$$M_{0q} = 22,5 \cdot 1,25 \cdot 1 \cdot 1,2 = 33,75 \text{ kNm}$$

Legend

M_{0q}	kNm	Equivalent tilting moment load (static)
M_{0k}	kNm	Static tilting moment load
f_A	-	Application factor
f_S	-	Factor for additional safety.

Determining the load point in the static limiting load diagram – checking the static load carrying capacity

Using the values for F_{0q} and M_{0q} , the load point in the static limiting load diagrams for the raceway and fixing screws is determined ► 1152 | ☐ 10 and ► 1152 | ☐ 11.

The load point is below the raceway and screw curves. The bearing is adequately dimensioned and thus suitable for the application.



10

*Static limiting load diagram
for raceway – compressive load*

M_{0q} = equivalent tilting moment
load

F_{0q} = equivalent bearing load

① Raceway curve

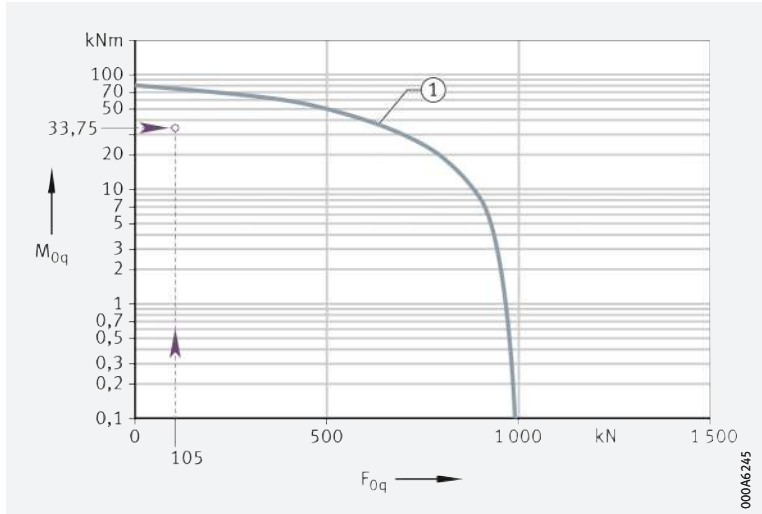

11

*Static limiting load diagram
for fixing screws – compressive load*

M_{0q} = equivalent tilting moment
load

F_{0q} = equivalent bearing load

① Screw curve

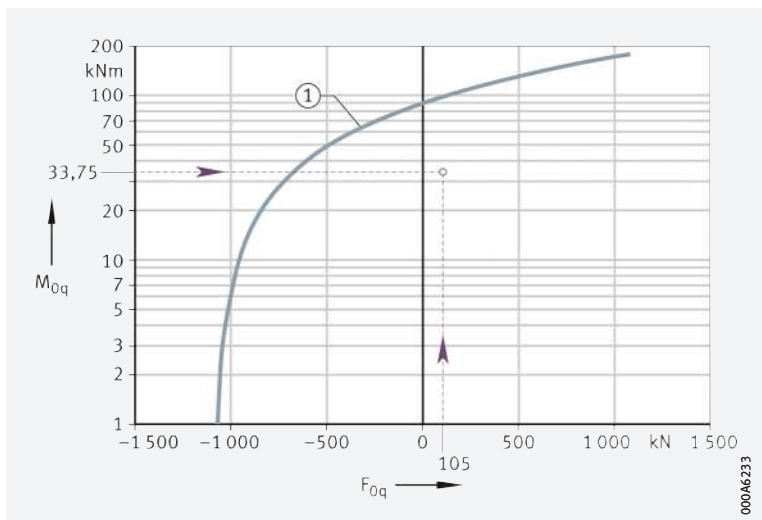

☞ *For bearings under
dynamic loading,
the dynamic load carrying
capacity applies*

Dynamic load carrying capacity

Dynamically loaded crossed roller bearings, i.e. bearings that undergo predominantly rotary motion, are dimensioned in accordance with their dynamic load carrying capacity. The size of a dynamically loaded bearing can therefore be checked in approximate terms using the basic dynamic load ratings C and the basic rating life L or L_h .

Determining the basic rating life

The life formulae for L and L_h are only valid:

- with a load arrangement according to ► 1153 | 12
- if all the requirements are fulfilled in relation to location (the bearing rings must be rigid or firmly connected to the adjacent construction), mounting, lubrication and sealing
- if the load and speed can be regarded as constant during operation. If the load and speed are not constant, equivalent operating values can be determined that will result in the same fatigue conditions as the actual loads
- if the load ratio is $F_r/F_a \leq 8$.



For more complex load arrangements, if a ratio $F_r/F_a > 8$ is present or there are variations from the specified conditions, please contact us.

12 Load arrangement

F_a = axial dynamic bearing load
 F_r = radial dynamic bearing load
 M_k = dynamic tilting moment load

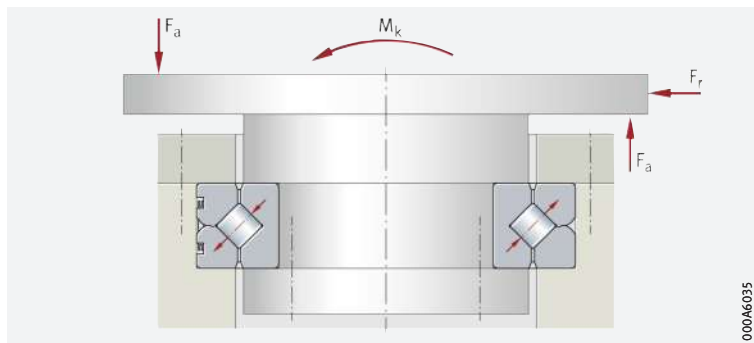

Determining the basic rating life for bearings subjected to combined loads

For bearings subjected to combined loads, in other words bearings with axial, radial and tilting moment loads, the rating life L or L_h is determined as follows:

- Determine the ratio of the radial dynamic bearing load F_r to the axial dynamic bearing load F_a (F_r/F_a)
- Calculate the load eccentricity parameter ϵ ▶ 1153 | f1 9
- Using the values for ϵ and the ratio F_r/F_a , determine the dynamic load factor k_F ▶ 1154 | 13
- Calculate the equivalent dynamic axial bearing load $P_a = k_F \cdot F_a$ ▶ 1153 | f1 10
- Enter the equivalent dynamic axial bearing load P_a and the basic dynamic axial load rating C_a in the rating life equations L or L_h respectively and calculate the rating life ▶ 1153 | f1 11 and ▶ 1153 | f1 12

If swivel operation is present, enter the operating speed n determined in the rating life equation L_h ▶ 1153 | f1 13.

f1 9
Load eccentricity parameter

$$\epsilon = \frac{2\,000 \cdot M_k}{F_a \cdot D_M}$$

f1 10
Equivalent dynamic axial bearing load

$$P_a = k_F \cdot F_a$$

f1 11
Basic rating life in millions of revolutions

$$L_{10} = \left(\frac{C_a}{P_a} \right)^p$$

f1 12
Basic rating life in operating hours

$$L_{10h} = \frac{16666}{n} \cdot \left(\frac{C_a}{P_a} \right)^p$$

f1 13
Operating speed

$$n = n_{osc} \cdot \frac{\gamma}{90^\circ}$$



13

Dynamic load factor

- k_F = dynamic load factor
- ϵ = load eccentricity parameter
- F_a = axial dynamic bearing load
- F_r = radial dynamic bearing load

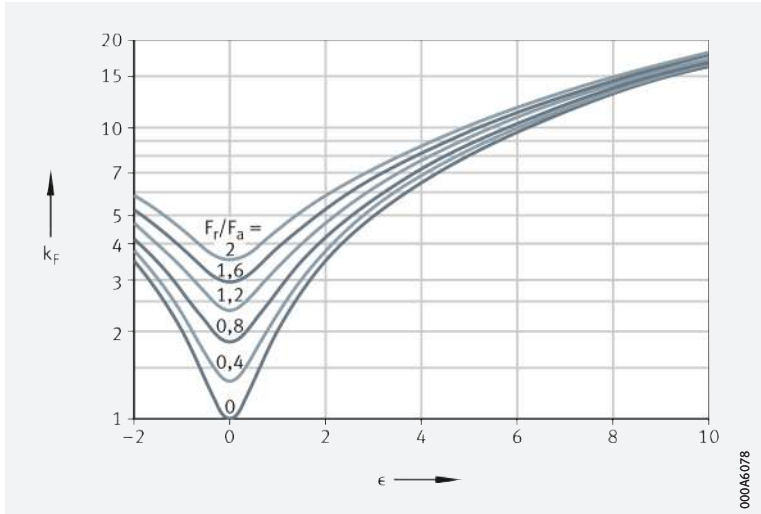

Determining the basic rating life for bearings subjected to radial loads only

For slewing rings subjected to radial loads only, the following values are entered in the rating life formulae L and L_h :

- $P_r = F_r$
- the basic dynamic radial load rating C_r .

f14

Basic rating life in millions of revolutions

$$L_{10} = \left(\frac{C_r}{P_r} \right)^p$$

f15

Basic rating life in operating hours



$$L_{10h} = \frac{16666}{n} \cdot \left(\frac{C_r}{P_r} \right)^p$$

Legend

ϵ	–	Load eccentricity parameter
M_k	kNm	Dynamic tilting moment load
F_a	kN	Axial dynamic bearing load
D_M	mm	Rolling element pitch circle diameter ▶ 1168
P_a	kN	Equivalent dynamic axial bearing load. For bearings subjected to radial load only, enter P_r
k_F	–	Dynamic load factor ▶ 1154 13
L_{10}	10^6	Basic rating life in millions of revolutions
C_a, C_r	kN	Basic axial or radial dynamic load rating ▶ 1168
p	–	Life exponent for crossed roller bearings: $p = 10/3$
L_{10h}	h	Basic rating life in operating hours
n	min^{-1}	Operating speed
n_{osc}	min^{-1}	Frequency of oscillating motion
γ	°	Half of swivel angle
P_r	kN	Equivalent dynamic radial bearing load
F_r	kN	Radial dynamic bearing load.

Calculation example

For the crossed roller bearing SX011820, the basic rating life L in millions of revolutions is to be checked.

 Given	Crossed roller bearing	SX011820
	Rolling element pitch circle diameter \blacktriangleright 1168 	$D_M = 112$ mm
	Basic dynamic load rating (axial) \blacktriangleright 1168 	$C_a = 28$ kN
	Life exponent for crossed roller bearings	$p = 10/3$
	Dynamic bearing load (axial)	$F_a = 20$ kN
	Dynamic bearing load (radial)	$F_r = 4$ kN
	Dynamic tilting moment load	$M_k = 1$ kNm

 **Required** Basic rating life L_{10} in millions of revolutions

Solution

 **f16**
Load eccentricity parameter

$$\epsilon = \frac{2\,000 \cdot M_k}{F_a \cdot D_M}$$





$$\epsilon = \frac{2\,000 \cdot 1}{20 \cdot 112} = 0,89$$

$$\frac{F_r}{F_a} = \frac{4}{20} = 0,2$$

$$k_F = 2,1$$

Legend

ϵ	–	Load eccentricity parameter
M_k	kNm	Dynamic tilting moment load
F_a	kN	Axial dynamic bearing load
D_M	mm	Rolling element pitch circle diameter \blacktriangleright 1168 
F_r	kN	Radial dynamic bearing load
k_F	–	Dynamic load factor \blacktriangleright 1154  13.

 **f17**
Equivalent bearing load (static)

$$P_a = k_F \cdot F_a$$



$$P_a = 2,1 \cdot 20 \text{ kN} = 42 \text{ kN}$$

Legend

P_a	kN	Equivalent dynamic axial bearing load. For bearings subjected to radial load only, enter P_r
k_F	–	Dynamic load factor \blacktriangleright 1154  13
F_a	kN	Axial dynamic bearing load.

 **f18**
Basic rating life
in million revolutions

$$L_{10} = \left(\frac{C_a}{P_a} \right)^p$$



$$L_{10} = \left(\frac{28}{42} \right)^{\frac{10}{3}} = 0,26 \cdot 10^6 \text{ revolutions}$$

Legend

L_{10}	10^6	Basic rating life in millions of revolutions For bearings subjected to radial load only, enter P_r
C_a, C_r	kN	Basic axial or radial dynamic load rating \blacktriangleright 1168 
P_a	kN	Equivalent dynamic axial bearing load. For bearings subjected to radial load only, enter P_r
p	–	Life exponent for crossed roller bearings: $p = 10/3$.

14

**Dynamic load factor k_F
for crossed roller bearings**

- k_F = dynamic load factor
- ϵ = load eccentricity parameter
- F_a = axial dynamic bearing load
- F_r = radial dynamic bearing load

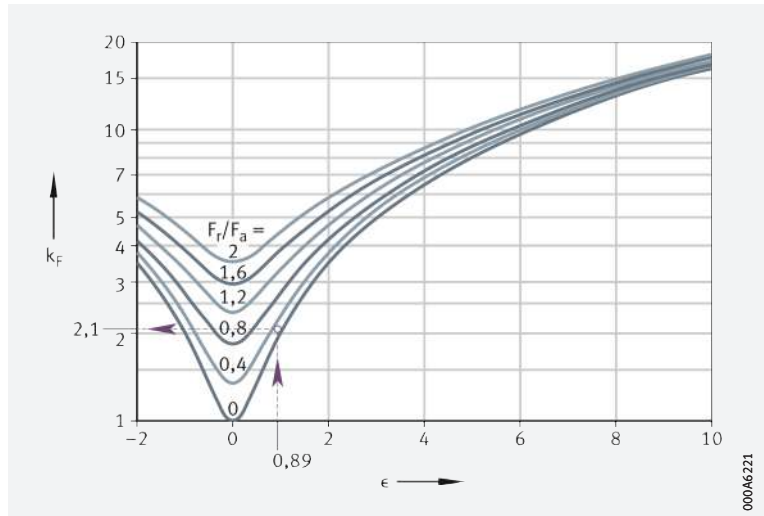

Determining the load carrying capacity of the fixing screws

In addition to the raceway, the load carrying capacity of the fixing screws must also be checked. This is based on the information in ► 1148.

The load carrying capacity of the fixing screws can be checked if the following conditions are fulfilled:

- the criteria according to ► 1148
 - the screws are tightened as specified using a torque wrench
 - screw tightening factor $\alpha_A = 1,6$
 - tightening torques ► 1161 | 8 to ► 1162 | 9
- the permissible contact pressure is not exceeded
- screws of the recommended size, quantity and grade are used.

Indicator of load carrying capacity

The load carrying capacity of the screws is described by:

- the curves in the static limiting load diagrams for fixing screws in the product tables
- the maximum permissible radial load $F_{r\text{per}}$ (friction locking).

The screw curves are shown in the static limiting load diagrams for fixing screws. The curves are based on screws of grade 10.9, tightened to 90% of their proof stress, including the torsion content.

If screws of grade 8.8 or 12.9 are used, the equivalent static loads F_{0q} and M_{0q} , ► 1148, must be converted using the following factors:

- grade 8.8 ($F_{0q} \cdot 1,65$, $M_{0q} \cdot 1,65$)
- grade 12.9 ($F_{0q} \cdot 0,8$, $M_{0q} \cdot 0,8$).

15

Static limiting load diagram for fixing screws – example for crossed roller bearing SX011860

M_{0q} = equivalent tilting moment load (static)

F_{0q} = equivalent axial bearing load (static)

① Screw curve

② Load point for screws of normal grade (10.9)

③ Load point for screws of grade 8.8

Static limiting load diagram for fixing screws – example

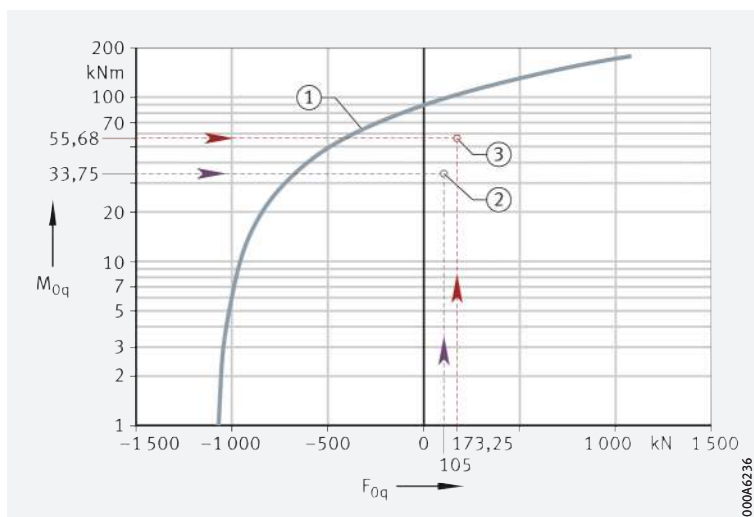

Checking the static load carrying capacity of the screws

The static load carrying capacity of the screw is limited by its proof stress.

For applications with and without radial load

The equivalent static bearing loads F_{0q} and M_{0q} must be determined.

Using the values F_{0q} and M_{0q} , the load point is then determined in the static limiting load diagram for fixing screws, see diagrams in product tables ► 1170 |

The load point must be below the appropriate screw curve.



Radial load and static load carrying capacity of the screws

If radial loads occur in uncentred bearing rings, the screw connections must prevent displacement of the bearing rings on the adjacent construction.

In order to check this:

- multiply the radial bearing load by an application factor f_A ► 1150 |
- compare the values determined with the maximum permissible radial load $F_{r\text{ per}}$.



The maximum radial load $F_{r\text{ per}}$ on the fixing screws is dependent on their friction locking and not on the radial load carrying capacity of the bearing.

If the radial load on the bearing is higher than the friction locking of the fixing screws or very high radial loads are present ($F_r/F_a > 4$), please contact us.

Checking the dynamic load carrying capacity of the screws

The dynamic load carrying capacity of the screws corresponds to the fatigue strength of the screw.

Dynamic load carrying capacity

Based on the dynamic loads present, the equivalent loads F_{0q} and M_{0q} are determined.

Instead of the application factor f_A , the operating load must always be increased by the following factor:

- grade 8.8 (factor 1,8),
- grade 10.9 (factor 1,6),
- grade 12.9 (factor 1,5).

The load carrying capacity must then be checked in the static limiting load diagram for the fixing screws ► 1168 |



The load point must be below the appropriate screw curve.



1.15 Minimum load

In order to prevent damage due to slippage, a minimum load is required

In order that no slippage occurs between the contact partners, the crossed roller bearings must be constantly subjected to a sufficiently high load. In most cases, however, the load is already sufficiently high due to the weight of the supported parts and the external forces.

1.16 Design of bearing arrangements

The design of the adjacent construction has a considerable influence on the function of the bearings

Crossed roller bearings SX can support high loads. Due to the X arrangement of the cylindrical rollers, these bearings can support axial forces in both directions, radial loads, tilting moment loads and any combinations of loads. In order that these advantages can be utilised comprehensively, the adjacent construction must be designed so that it is appropriately rigid. The bearing rings must always be rigidly and uniformly supported over the circumference and width of the rings [▶ 1158](#)  16.





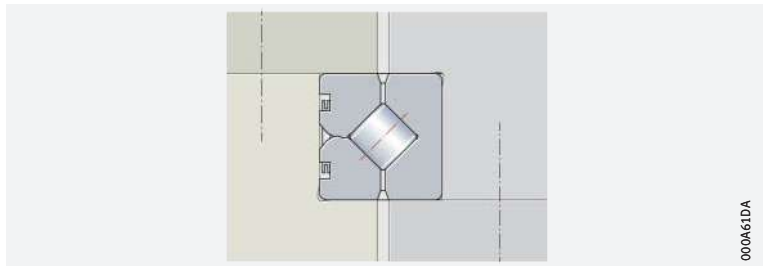

The adjacent construction must be designed only in accordance with the information in this section. Any deviations from the specifications, material strength and adjacent components will considerably reduce the load carrying capacity and operating life of the bearings.





 **16**
Uniform support
of the bearing rings
by the adjacent construction



000A61DA

Shaft and housing tolerances

For normal applications, the tolerance class K7  for the housing and h7  for the shaft are sufficient [▶ 1158](#)  5 and [▶ 1159](#)  6.

In precision applications, the bearing seat in the housing should be designed to tolerance class K6  and on the shaft to h6  [▶ 1158](#)  5 and [▶ 1159](#)  6.

 **5**
Mounting tolerances
for the shaft

Nominal dimension d_i mm		Tolerance classes			
>	≅	h6		h7	
		Upper deviation μm	Lower deviation μm	Upper deviation μm	Lower deviation μm
65	80	0	-19	0	-30
80	100	0	-22	0	-35
100	120	0	-22	0	-35
120	140	0	-25	0	-40
140	160	0	-25	0	-40
160	180	0	-25	0	-40

continued ▼

5
Mounting tolerances
for the shaft

Nominal dimension d_i mm		Tolerance classes			
>	\leq	h6		h7	
		Upper deviation μm	Lower deviation μm	Upper deviation μm	Lower deviation μm
180	200	0	-29	0	-46
200	225	0	-29	0	-46
225	250	0	-29	0	-46
250	280	0	-32	0	-52
280	315	0	-32	0	-52
315	355	0	-36	0	-57
355	400	0	-36	0	-57
400	450	0	-40	0	-63
450	500	0	-40	0	-63

continued ▲

6
Mounting tolerances
for the housing bore

Nominal dimension D_a mm		Tolerance classes			
>	\leq	K6		K7	
		Upper deviation μm	Lower deviation μm	Upper deviation μm	Lower deviation μm
80	100	+4	-18	+10	-25
100	120	+4	-18	+10	-25
120	140	+4	-21	+12	-28
140	160	+4	-21	+12	-28
160	180	+4	-21	+12	-28
180	200	+5	-24	+13	-33
200	225	+5	-24	+13	-33
225	250	+5	-24	+13	-33
250	280	+5	-27	+16	-36
280	315	+5	-27	+16	-36
315	355	+7	-29	+17	-40
355	400	+7	-29	+17	-40
400	450	+8	-32	+18	-45
450	500	+8	-32	+18	-45
500	560	0	-44	0	-70
560	630	0	-44	0	-70



Location using clamping rings

For the location of crossed roller bearings SX, clamping rings have proved effective ► 1161 | 17.



The bearing rings must always be rigidly and uniformly supported over the circumference and width of the rings.

The thickness of the clamping rings and mounting flanges must not be less than the minimum thickness s .

Counterbores to DIN 74, type J, for screws to DIN 6912 are permissible. For deeper counterbores, the thickness of the clamping ring s must be increased by the additional counterbore depth.

Mounting dimensions ► 1160 | 7 and ► 1161 | 17. Minimum strength of clamping rings ► 1160.

Bearing seat depth

In order that the clamping rings retain the bearing securely, the bearing seat depth t must be in accordance with the specification ► 1160 | 7 and ► 1161 | 17.



The depth of the bearing seat influences the bearing clearance and the rotational resistance.

Bearings with preload (suffix VSP) have a considerably higher rotational resistance.

If particular requirements for rotational resistance apply, the depth t must be produced to match the relevant height of the bearing ring. It has proved effective to tolerance the depth t to deviations that are the same as or further restricted compared to the dimension h in the product tables. For safety, internal tests should in any case be carried out.

Minimum strength of clamping rings

For screws of grade 10.9, the minimum strength under the screw heads or nuts must be 500 N/mm^2 . Seating washers are not necessary for these screws.

For fixing screws of grade 12.9, the minimum strength must not be less than 850 N/mm^2 , otherwise quenched and tempered seating washers under the screw heads or quenched and tempered nuts must be used.

 7
Mounting dimensions

Designation	Mounting dimensions in mm									
	d_i h7 (h6)	D_a K7 (K6)	t	s min.	d_{Ra}	d_{Ri}	D_{Ri}	D_{Ra}	L_i max.	L_a min.
SX011814	70	90	10 -0,005 -0,015	8	78	42	82	118	60	100
SX011818	90	115	13 -0,005 -0,020	10	100	61	104	144	80	125
SX011820	100	125	13 -0,005 -0,020	10	110	71	114	154	90	135
SX011824	120	150	16 -0,005 -0,025	12	132	84	138	186	108	162
SX011828	140	175	18 -0,005 -0,030	14	154	94	160	221	124	191
SX011832	160	200	20 -0,02 -0,05	15	177	111	183	249	144	216
SX011836	180	225	22 -0,02 -0,05	17	199	121	205	284	160	245
SX011840	200	250	24 -0,02 -0,06	18	221	139	229	311	180	270
SX011848	240	300	28 -0,02 -0,06	21	269	166	274	374	216	324
SX011860	300	380	38 -0,04 -0,10	29	335	201	345	479	268	412
SX011868	340	420	38 -0,04 -0,10	29	375	241	385	519	308	452
SX011880	400	500	46 -0,04 -0,10	35	445	275	455	625	360	540
SX0118/500	500	620	56 -0,04 -0,10	42	554	350	566	700	452	668

17

Clamping rings, bearing seat depth, mounting dimensions

- ① Slots, threaded extraction hole or similar for dismounting purposes

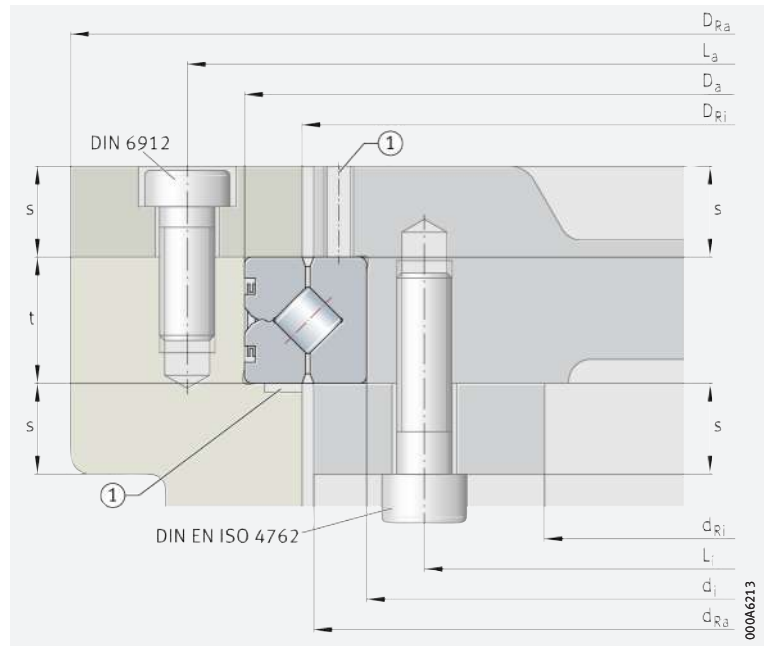

Fixing screws

For the location of the bearing rings or clamping rings, screws of grade 10.9 are suitable ▶ 1161 | 8.



Any deviations from the recommended size, grade and quantity of screws will considerably reduce the load carrying capacity and operating life of the bearings.

For screws of grade 12.9, the minimum strength of the clamping rings must be achieved or quenched and tempered seating washers must be used.



Fixing screws

Crossed roller bearings	Fixing screws Grade 10.9		Tightening torque
	Dimension	Quantity	M _A Nm
SX011814	M5	18	7
SX011818	M5	24	7
SX011820	M5	24	7
SX011824	M6	24	11,7
SX011828	M8	24	27,8
SX011832	M8	24	27,8
SX011836	M10	24	55,6
SX011840	M10	24	55,6
SX011848	M12	24	98,4
SX011860	M16	24	247
SX011868	M16	24	247
SX011880	M20	24	481
SX0118/500	M24	24	831

Securing of screws

Normally, the screws are adequately secured by the correct preload **► 1162** | **9** and **► 1162** | **10**. If regular shock loads or vibrations occur, however, additional securing of the screws may be necessary.



Not every method of securing screws is suitable for crossed roller bearings. Never use spring washers or split washers.

General information on securing of screws is given in DIN 25201-4:2004. If these are to be used, please consult the relevant companies.

9
Tightening torques M_A
for the torque-controlled
tightening of socket headless
screws

Fixing screw	Clamping cross-section A_S mm ²	Core cross-section A_{d3} mm ²	Tightening torque $M_A^{1)}$ in Nm for grade		
			8.8	10.9	12.9
M4	8,78	7,75	2,25	3,31	3,87
M5	14,2	12,7	4,61	6,77	7,92
M6	20,1	17,9	7,8	11,5	13,4
M8	36,6	32,8	19,1	28	32,8
M10	58	52,3	38	55,8	65,3
M12	84,3	76,2	66,5	97,7	114
M14	115	105	107	156	183
M16	157	144	168	246	288
M18	192	175	229	336	394
M20	245	225	327	481	562
M22	303	282	450	661	773
M24	353	324	565	830	972

¹⁾ M_A in accordance with guideline VDI 2230 (February 2003) for $\mu_K = 0,08$ and $\mu_G = 0,12$.

10
Assembly preload forces F_M
for the torque-controlled
tightening of socket headless
screws

Fixing screw	Clamping cross-section A_S mm ²	Core cross-section A_{d3} mm ²	Mounting preload force $F_M^{1)}$ in kN for grade		
			8.8	10.9	12.9
M4	8,78	7,75	4,05	5,95	6,96
M5	14,2	12,7	6,63	9,74	11,4
M6	20,1	17,9	9,36	13,7	16,1
M8	36,6	32,8	17,2	25,2	29,5
M10	58	52,3	27,3	40,2	47
M12	84,3	76,2	39,9	58,5	68,5
M14	115	105	54,7	80,4	94,1
M16	157	144	75,3	111	129
M18	192	175	91,6	134	157
M20	245	225	118	173	202
M22	303	282	147	216	253
M24	353	324	169	249	291

¹⁾ F_M in accordance with guideline VDI 2230 (February 2003) for $\mu_G = 0,12$.

1.17 Mounting and dismounting

Mounting of crossed roller bearings

The bores and edges of the adjacent components must be free from burrs. The support surfaces for the bearing rings must be clean.

The seating and locating surfaces for the bearing rings on the adjacent construction must be lightly oiled or greased.

Lightly oil the thread of the fixing screws in order to prevent varying friction factors (do not oil or grease screws that will be secured by means of adhesive).



Ensure that all adjacent components and lubrication ducts are free from cleaning agents, solvents and washing emulsions. The bearing seat surfaces can rust or the raceway system can become contaminated.

Mounting forces must only be applied to the bearing ring to be mounted; forces must never be directed through the rolling elements or seals. Avoid direct blows on the bearing rings in all cases.

Locate the bearing rings consecutively and without application of any external load.

The outer ring is split and is held together by three retaining rings ①
 ► 1163 | 18. Never apply tensile loads to the retaining rings.

Locating the outer bearing ring

Mounting of the ring ► 1163 | 18:

- Insert or press the bearing ② into the external adjacent construction ③ with the outer ring first
- Position the external clamping ring ④
- Insert the fixing screws ⑤ in the clamping ring and tighten in steps up to the specified tightening torque M_A
 - tighten the screws in a crosswise sequence in order to prevent unacceptable fluctuations in the screw tensioning forces
 - tightening torques M_A for fixing screws ► 1162 | 9.



18
 Locating the outer bearing ring

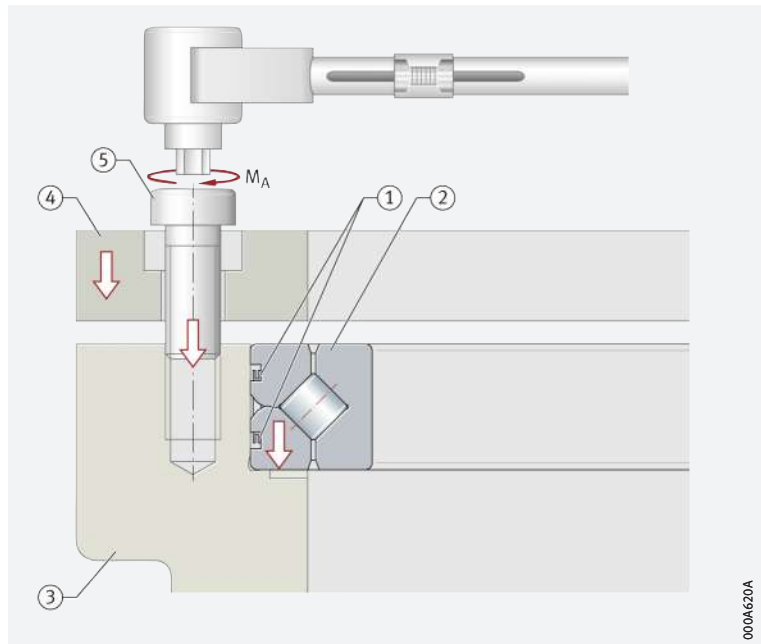

Locating the inner bearing ring

Mounting of the ring ► 1164 | 19:

- Insert the bearing ② into the internal adjacent construction ⑥
- Position the internal clamping ring ⑦
- Insert the fixing screws ⑧ in the clamping ring and tighten in steps up to the specified tightening torque M_A
 - tighten the screws in a crosswise sequence in order to prevent unacceptable fluctuations in the screw tensioning forces.

19
Locating the inner bearing ring

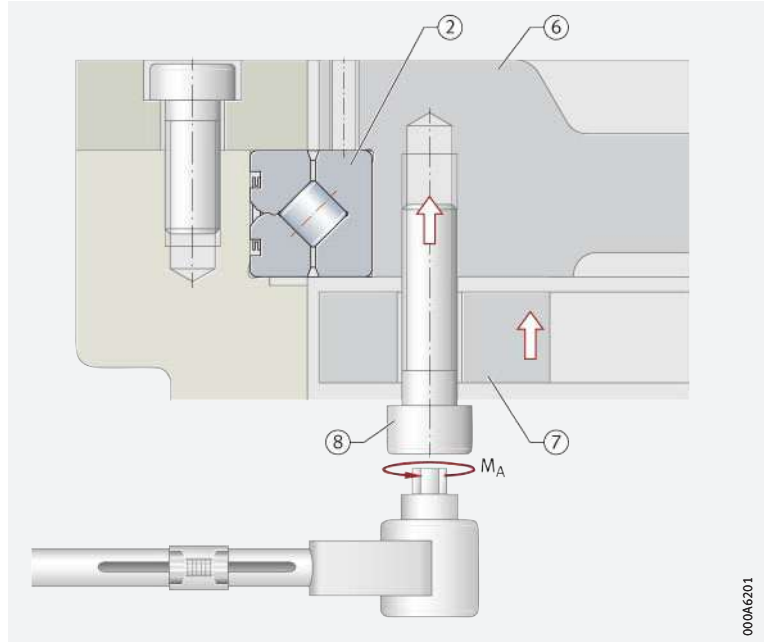

Checking the function



Once mounting is complete, the operation of the mounted crossed roller bearing must be checked. If the bearing runs irregularly or roughly, or the temperature in the bearing shows an unusual increase, the bearing must be dismantled, checked and mounted again in accordance with the mounting guidelines described.

Possible causes of deviations in values

Checking the running accuracy

The running accuracy must be checked by means of a dial gauge. The corresponding values are taken from the mounting drawing or the product tables. Deviations from the values may be the result of:

- inaccuracies in the adjacent construction
- braced bearings due to incorrectly tightened clamping rings, fixing screws or locknuts.

Factors influencing the rotational resistance

Checking the rotational resistance

The rotational resistance is essentially determined by:

- the rolling resistance of the rolling elements
- the internal clearance or bearing preload
- the friction of the spacers
- the friction of the seals
- the grease
- a deformed or defective adjacent construction
- errors during mounting.

⌚ *Preload, rotational resistance, bearing temperature*

Due to the preload in the rolling element system, the rotational resistance is higher than in a bearing with clearance. At higher speeds, a high preload can lead to generation of significant heat in the bearing. In such applications, tests must be carried out if necessary with bearings preloaded to various values.

⌚ *Possible causes of high temperatures*

Checking the bearing temperature

After commissioning, the temperature in the bearing can increase; in the case of grease lubrication, this may continue until the grease is evenly distributed in the bearing. A further increase or unusually high temperatures may be caused by one of the following:

- The bearing is lubricated using an unsuitable grease
- There is too much lubricant in the bearing
- The bearing load is too high
- The bearing is mounted unevenly
- The adjacent construction deviates from the specifications.

Schaeffler Mounting Handbook

⌚ *Rolling bearings must be handled with great care*

Rolling bearings are well-proven precision machine elements for the design of economical and reliable bearing arrangements, which offer high operational security. In order that these products can function correctly and achieve the envisaged operating life without detrimental effect, they must be handled with care.



The Schaeffler Mounting Handbook MH 1 gives comprehensive information about the correct storage, mounting, dismounting and maintenance of rotary rolling bearings ► <https://www.schaeffler.de/std/1D53>. It also provides information which should be observed by the designer, in relation to the mounting, dismounting and maintenance of bearings, in the original design of the bearing position. This book is available from Schaeffler on request.



1.18 Legal notice regarding data freshness

The further development of products may also result in technical changes to catalogue products

Of central interest to Schaeffler is the further development and optimisation of its products and the satisfaction of its customers. In order that you, as the customer, can keep yourself optimally informed about the progress that is being made here and with regard to the current technical status of the products, we publish any product changes which differ from the printed version in our electronic product catalogue.



We therefore reserve the right to make changes to the data and illustrations in this catalogue. This catalogue reflects the status at the time of printing. More recent publications released by us (as printed or digital media) will automatically precede this catalogue if they involve the same subject. Therefore, please always use our electronic product catalogue to check whether more up-to-date information or modification notices exist for your desired product.

Link to electronic product catalogue



The following link will take you to the Schaeffler electronic product catalogue: ► <https://medias.schaeffler.com>.

1.19 Further information



In addition to the data in this chapter, the following chapters in Technical principles must also be observed in the design of bearing arrangements:

- Determining the bearing size ► 34
- Rigidity ► 54
- Friction and increases in temperature ► 56
- Speeds ► 64
- Bearing data ► 97
- Lubrication ► 70
- Sealing ► 182
- Design of bearing arrangements ► 139
- Mounting and dismounting ► 191.





Crossed roller bearings

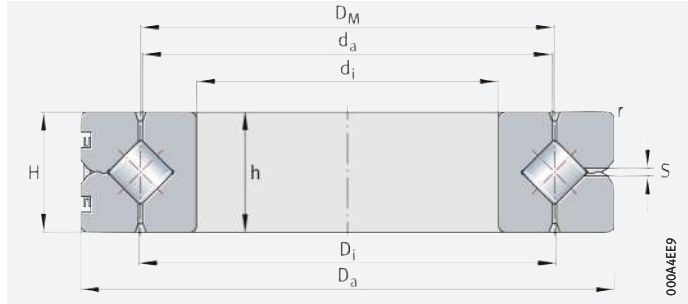

SX

00044EP

$d_i = 70 - 160 \text{ mm}$

Main dimensions			Basic load ratings				Limiting speeds				Mass	Designation	Dimensions identical to deep groove ball bearing 618
d_i	D_a	$H^{1)}$	axial		radial ²⁾		with standard clearance		with preload		m ≈ kg	▶ 1147 1.12 ▶ 1147 1.13	
			dyn. C_a kN	stat. C_{0a} kN	dyn. C_r kN	stat. C_{0r} kN	n_G oil min^{-1}	n_G grease min^{-1}	n_G oil min^{-1}	n_G grease min^{-1}			
70 +0,004 -0,015	90 0 -0,022	10 +0,06 -0,06	16,6	52	11,8	25,5	1910	955	955	475	0,3	SX011814	
90 +0,004 -0,018	115 0 -0,022	13 +0,06 -0,06	26,5	87	18,9	43	1500	750	750	375	0,4	SX011818	61818
100 +0,004 -0,018	125 0 -0,025	13 +0,06 -0,06	28	97	20	47,5	1360	680	680	340	0,5	SX011820	61820
120 +0,004 -0,018	150 0 -0,025	16 +0,06 -0,06	39,5	140	28	69	1130	565	565	280	0,8	SX011824	61824
140 +0,004 -0,021	175 0 -0,025	18 +0,06 -0,06	64	223	45,5	109	975	485	485	240	1,1	SX011828	61828
160 +0,004 -0,021	200 0 -0,029	20 +0,10 -0,10	69	255	49	126	850	425	425	210	1,7	SX011832	61832

medias ▶ <https://www.schaeffler.de/std/1E26>

- 1) H = section height of bearing, h = height of individual ring.
- 2) Basic load ratings, radial: for radial loads only.

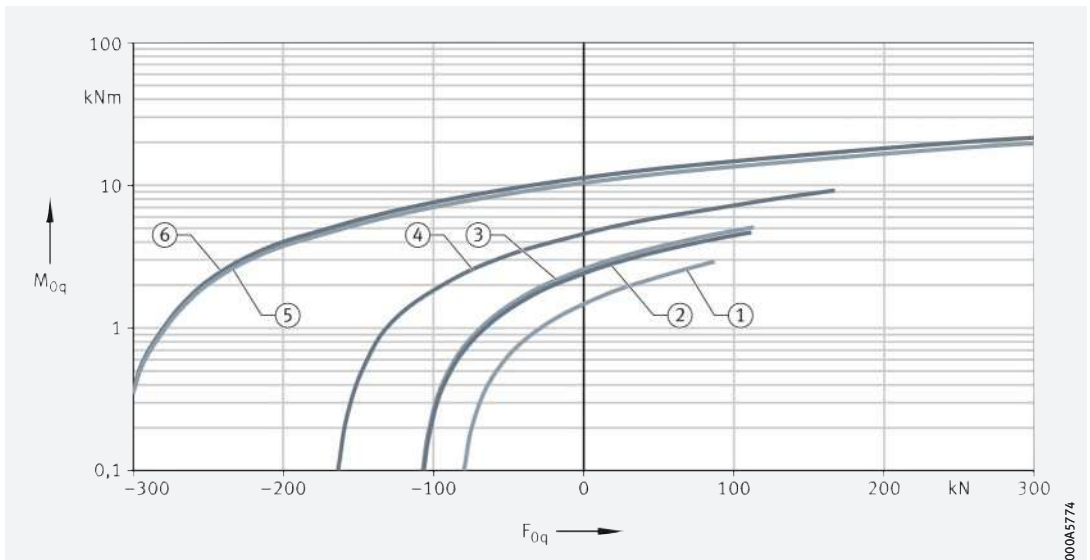

Static limiting load diagrams for fixing screws – compressive load

00045774



Dimensions								Running accuracy		Normal clearance				Low clearance RLO		Preload VSP		Position: see diagram
d_i	D_M	$h^{1)}$		d_a	D_i	r	S	radial	axial	Radial clearance		Axial tilting clearance		Radial clearance	Pre-load	min.	max.	
						min.				min.	max.	min.	max.	max.	max.			
										min.	max.	min.	max.	max.	max.			
70	80	10	0 -0,01	79,5	80,5	0,6	1,2	0,01	0,01	0,003	0,015	0,006	0,03	0,003	0,006	0,003	0,015	①
90	102	13	0 -0,01	101,5	102,5	1	1,2	0,01	0,01	0,003	0,015	0,006	0,03	0,003	0,006	0,003	0,015	②
100	112	13	0 -0,01	111,5	112,5	1	1,2	0,01	0,01	0,005	0,02	0,01	0,04	0,004	0,008	0,005	0,02	③
120	135	16	0 -0,01	134,4	135,6	1	1,5	0,01	0,01	0,005	0,02	0,01	0,04	0,004	0,008	0,005	0,02	④
140	157	18	0 -0,01	156,3	157,7	1,1	1,5	0,015	0,01	0,005	0,02	0,01	0,04	0,004	0,008	0,005	0,02	⑤
160	180	20	0 -0,025	179,2	180,8	1,1	1,5	0,015	0,01	0,005	0,02	0,01	0,04	0,004	0,008	0,005	0,02	⑥

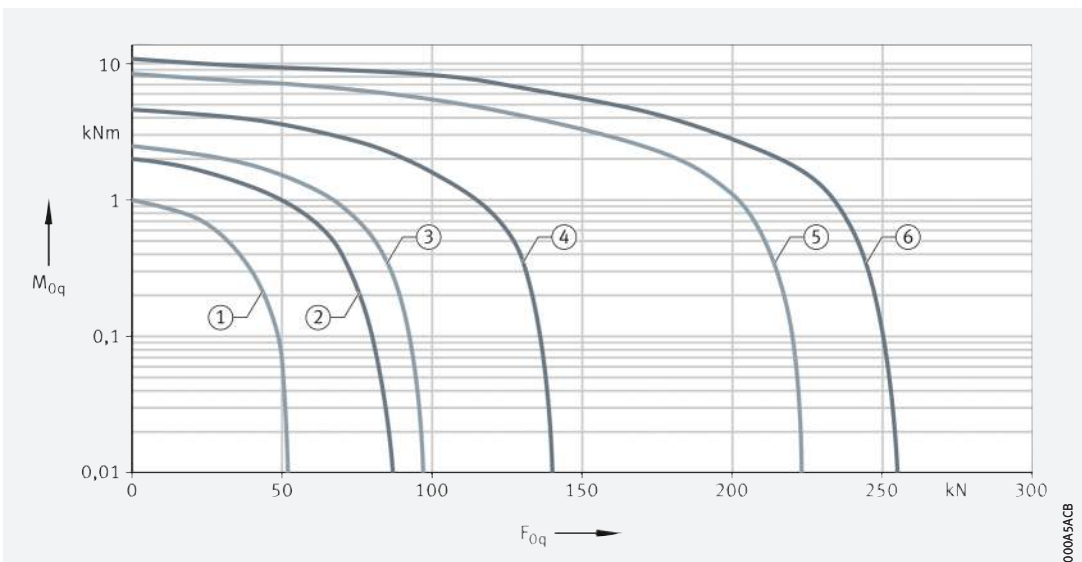

000A5ACB

Static limiting load diagrams for raceway – compressive load

Crossed roller bearings

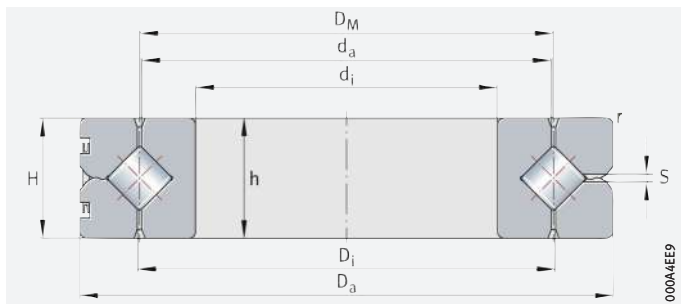

SX

$d_i = 180 - 500 \text{ mm}$

Main dimensions			Basic load ratings				Limiting speeds				Mass	Designation	Dimensions identical to deep groove ball bearing 618
d_i	D_a	$H^{1)}$	axial		radial ²⁾		with standard clearance		with preload		m	▶ 1147 1.12 ▶ 1147 1.13	
K6	h6		dyn. C_a kN	stat. C_{0a} kN	dyn. C_r kN	stat. C_{0r} kN	n_G oil min^{-1}	n_G grease min^{-1}	n_G oil min^{-1}	n_G grease min^{-1}	≈ kg		
180 $+0,004$ $-0,021$	225 0 -0,029	22 $+0,10$ $-0,10$	98	360	70	177	755	375	375	185	2,3	SX011836	
200 $+0,004$ $-0,024$	250 0 -0,029	24 $+0,10$ $-0,10$	104	400	74	197	680	340	340	170	3,1	SX011840	61840
240 $+0,005$ $-0,024$	300 0 -0,032	28 $+0,10$ $-0,10$	149	600	106	295	565	280	280	140	5,3	SX011848	61848
300 $+0,005$ $-0,027$	380 0 -0,036	38 $+0,14$ $-0,14$	245	990	174	485	450	225	225	110	12	SX011860	61860
340 $+0,007$ $-0,029$	420 0 -0,04	38 $+0,14$ $-0,14$	265	1 130	187	550	400	200	200	100	13,5	SX011868	61868
400 $+0,007$ $-0,029$	500 0 -0,04	46 $+0,15$ $-0,15$	385	1 660	275	810	340	170	170	85	24	SX011880	61880
500 $+0,008$ $-0,032$	620 0 -0,044	56 $+0,16$ $-0,16$	560	2 550	395	1 250	275	135	135	65	44	SX0118/500	618/500

medias ▶ <https://www.schaeffler.de/std/1E27>

- 1) H = section height of bearing, h = height of individual ring.
- 2) Basic load ratings, radial: for radial loads only.

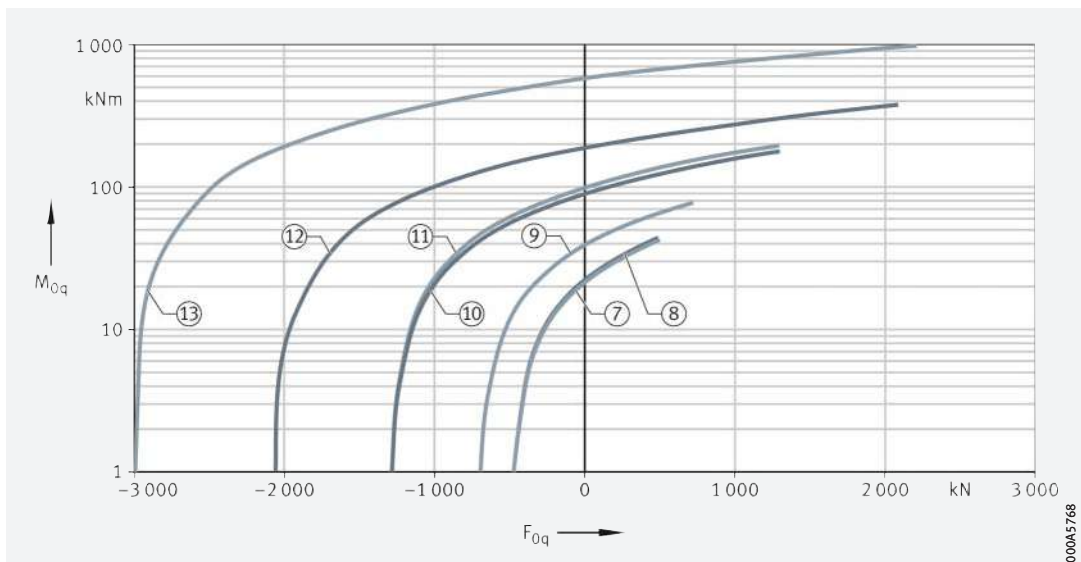

Static limiting load diagrams for fixing screws – compressive load



Dimensions								Running accuracy		Normal clearance				Low clearance RL0		Preload VSP		Position: see diagram
d_i	D_M	$h^{1)}$		d_a	D_i	r	S	radial	axial	Radial clearance		Axial tilting clearance		Radial clearance	Preload	min.	max.	
		0	-0,025			min.				min.	max.	min.	max.	max.	max.			
180	202	22	0 -0,025	201,2	202,8	1,1	2	0,015	0,01	0,005	0,025	0,01	0,05	0,005	0,01	0,005	0,025	⑦
200	225	24	0 -0,025	224,2	225,8	1,5	2	0,015	0,01	0,005	0,025	0,01	0,05	0,005	0,01	0,005	0,025	⑧
240	270	28	0 -0,025	269,2	270,8	2	2	0,02	0,01	0,01	0,03	0,02	0,06	0,005	0,01	0,005	0,025	⑨
300	340	38	0 -0,05	339,2	340,8	2,1	2,5	0,02	0,01	0,01	0,04	0,02	0,08	0,005	0,01	0,005	0,025	⑩
340	380	38	0 -0,05	379,2	380,8	2,1	2,5	0,025	0,01	0,01	0,04	0,02	0,08	0,005	0,01	0,005	0,025	⑪
400	450	46	0 -0,05	449	451	2,1	2,5	0,03	0,01	0,01	0,05	0,02	0,1	0,005	0,01	0,005	0,025	⑫
500	560	56	0 -0,05	558,8	561,2	3	2,5	0,04	0,01	0,015	0,06	0,03	0,12	0,006	0,012	0,005	0,03	⑬

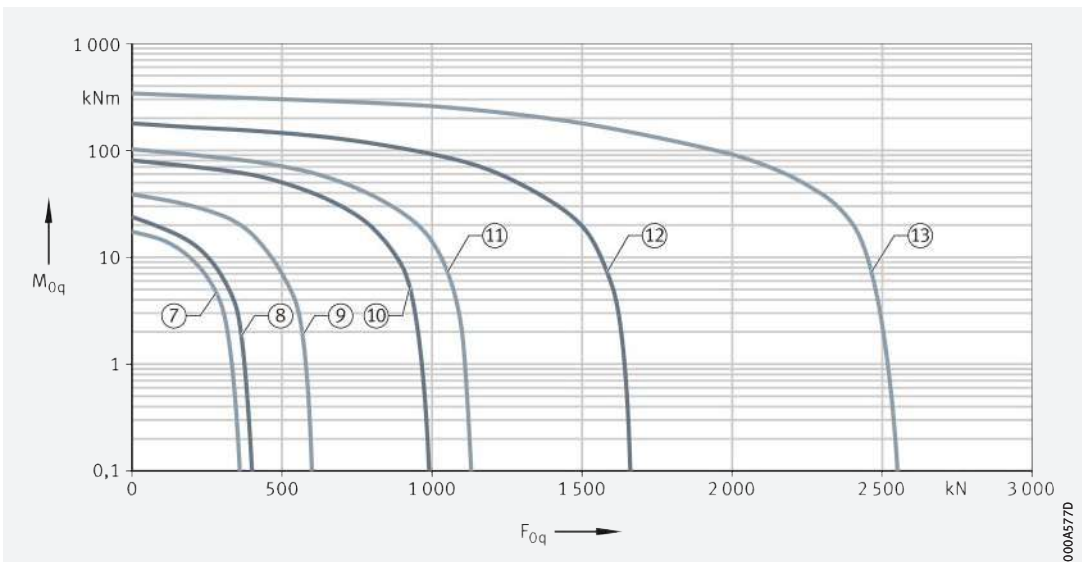

Static limiting load diagrams for raceway – compressive load

Super precision bearings



1 Bearings for main spindles **1174**

1.1	General features	1174
1.2	Super precision angular contact ball bearings	1174
1.3	Super precision cylindrical roller bearings	1175
1.4	Super precision axial bearings	1176
	Product tables	1178
	Super precision angular contact ball bearings	1178
	Super precision angular contact ball bearings in Direct Lube design	1236
	Super precision cylindrical roller bearings, single row	1248
	Super precision cylindrical roller bearings, double row	1256
	Super precision axial angular contact ball bearings 2344	1262
	Super precision angular contact ball bearings BAX	1264

2 Bearings for screw drives **1268**

- 2.1 General features 1268
- 2.2 Axial angular contact ball bearings 1268
- 2.3 Needle roller/axial cylindrical roller bearings 1272
- 2.4 Accessories 1274

Product tables 1276

	Axial angular contact ball bearings with fixing holes 1276
	Axial angular contact ball bearings with fixing holes, less stringent tolerances 1284
	Axial angular contact ball bearings with fixing holes, matched pair 1286
	Axial angular contact ball bearings without fixing holes 1288
	Axial angular contact ball bearings without fixing holes, less stringent tolerances 1296
	Axial angular contact ball bearings without fixing holes, matched pair 1298
	Axial angular contact ball bearings, single direction, open 1300
	Axial angular contact ball bearings, single direction, sealed on both sides 1310
	Angular contact ball bearing units, for screw mounting 1314
	Double row axial angular contact ball bearings with flange, with fixing holes 1316
	Triple row axial angular contact ball bearings with flange, with fixing holes 1320
	Needle roller/axial cylindrical roller bearings, light series, with fixing holes 1324
	Needle roller/axial cylindrical roller bearings, heavy series, with fixing holes 1328
	Needle roller/axial cylindrical roller bearings, light series, without fixing holes 1334
	Needle roller/axial cylindrical roller bearings, heavy series, without fixing holes 1338

Product tables 1344

	Seal carrier assemblies for ZARF 1344
	Precision locknuts, for axial clamping 1346
	Precision locknuts, for radial clamping 1347
	Sockets 1349

3 Bearings for combined loads **1352**

- 3.1 General features 1352
- 3.2 Axial/radial bearings, axial angular contact ball bearings 1352
- 3.3 Axial/radial bearings with incremental angular measuring system 1354
- 3.4 Axial/radial bearings with absolute value angular measuring system 1355

Product tables 1358

	Axial/radial bearings YRT 1358
	Axial/radial bearings YRTC 1360
	Axial/radial bearings YRTS 1362
	Axial angular contact ball bearings ZKLDF 1364
	Axial/radial bearings YRTM, YRTCM, with incremental angular measuring system 1366
	Axial/radial bearings YRTSM, with incremental angular measuring system 1368
	Axial/radial bearings YRTCMA, with absolute value angular measuring system 1370
	Axial/radial bearings YRTSMA, with absolute value angular measuring system 1372

4 App for super precision bearings **1374**

- 4.1 PrecisionDesk 1374







1 Bearings for main spindles

1.1 General features

Design variants

Bearings for main spindles are available as:

- super precision angular contact ball bearings ► 1175 |  1
 - single row, as single bearings or in sets
 - contact angle 15°, 25°
 - with large or small balls
 - rolling elements made from rolling bearing steel or ceramic
 - rings made from rolling bearing steel or Cronidur
 - Direct Lube bearings
- super precision cylindrical roller bearings ► 1175 |  2
 - single row
 - double row
 - rolling elements made from rolling bearing steel or ceramic
 - cages made from brass, polyamide or PEEK
- super precision axial bearings, i.e. super precision axial angular contact ball bearings 2344 ► 1176 |  3, super precision angular contact ball bearings BAX ► 1177 |  4
 - double direction
 - contact angle 30°, 40°, 60°
 - rolling elements made from rolling bearing steel
 - rings made from rolling bearing steel
 - cages made from brass, laminated fabric.

Product catalogue



The standard range of these bearings is described in detail in Spindle Bearing Catalogue ►  SP 1 and in our electronic product catalogue **medias professional**.

Printed catalogue

The Spindle Bearing Catalogue SP 1 can be requested from Schaeffler. Download and ordering at ► <https://www.schaeffler.de/std/1D58>.

medias

The following link will take you to the Schaeffler electronic product selection and information system: ► <https://medias.schaeffler.com>.

App for services

The app “PrecisionDesk” offers extensive services for rotary and linear bearings of a super precision design and assists fitters and engineers in the selection and mounting of bearings. Further information on PrecisionDesk ► 1374, download ► <https://www.schaeffler.de/std/1D59>.

1.2 Super precision angular contact ball bearings

FAG super precision angular contact ball bearings are single row angular contact ball bearings with solid outer and inner rings, and ball and cage assemblies with solid window cages ► 1175 |  1. The dimensions are standardised.

Suitable for applications with very high guidance accuracy

Due to their very narrow tolerances, the bearings are particularly suitable for applications involving the highest requirements for guidance accuracy, rigidity and speed suitability, such as bearing arrangements for main spindles in machine tools.



The product range of super precision angular contact ball bearings is presented in the product tables ► 1178 | . In addition to the products listed therein, further designs are available by agreement.

1

Universal super precision angular contact ball bearings (universal spindle bearings)

α = nominal contact angle
 F_a = axial load
 F_r = radial load

- ① Spindle bearing with balls made from rolling bearing steel
- ② Spindle bearing with balls made from ceramic
- ③ Direct Lube spindle bearing

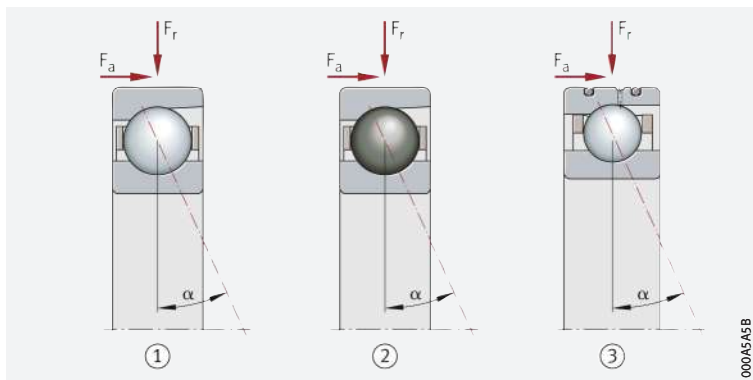

Extensive range for main spindle bearing arrangements, primarily in machine tools

Increased performance

This extensive product range gives the designer all possible scope for designing technically innovative, operationally secure and economical bearing arrangements. This results in significant performance improvements and cost savings as standard in machine tools. However, other machines, such as turbochargers for example, can benefit from these bearings.

In new designs, this can allow the machine manufacturer to achieve a unique position in the market. In existing designs too, refitting with FAG spindle bearings can still give further increases in the performance and profitability of machines.

1.3

Super precision cylindrical roller bearings

Features

FAG super precision cylindrical roller bearings comprise solid outer rings, solid inner rings with a tapered bore (taper 1:12) and cylindrical roller and cage assemblies with cages made from polyamide, brass or PEEK (polyetheretherketone) ▶ 1175 | 2. The outer ring is removable and can thus be mounted separately from the rest of the bearing package. The inner ring is only removable in the case of series NNU49.



FAG super precision cylindrical roller bearings are also available by agreement with a cylindrical bore.

2

Super precision cylindrical roller bearings

F_r = radial load

- ① Single row, tapered bore, N10
- ② Single row, tapered bore, ceramic rolling elements: HCN10
- ③ Double row, tapered bore, NN30, NNU49

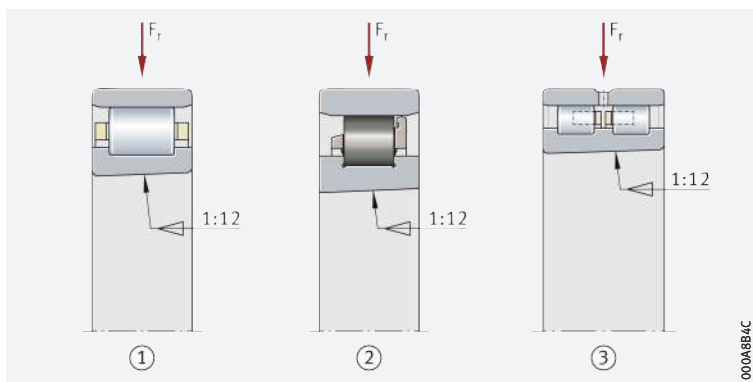

Areas of application

The single and double row bearings are used when the very highest precision is required under very high radial load. Typical areas of application include machine tools and printing machinery. The bearings facilitate bearing arrangements with very high precision, high radial rigidity and very high load carrying capacity. In machine tool building, they provide radial support for the main spindle.



Ideal non-locating bearings

Since variations in length during rotary motion can be compensated between the rollers and the ribless raceway without constraining forces, the cylindrical roller bearings are highly suitable as non-locating bearings. Axial forces are supported by axial bearings, such as double direction axial angular contact ball bearings or super precision angular contact ball bearings BAX. The standard series N10, HCN10 (single row) and NN30, NNU49 (double row) are an established part of the FAG super precision range [▶ 1248](#) | .



Diameter ranges not shown in the catalogue are available by agreement.

X-life

X-life premium quality

The super precision cylindrical roller bearings N10 and NN30 in the X-life design have a higher load carrying capacity and thus a significantly increased bearing rating life. A newly developed plastic cage gives lower friction than the previous standard design with brass cage.

Increased customer benefits due to X-life

The advantages of this bearing design include:

- limiting speeds up to 35% higher
- running temperatures up to 12 K lower
- lower noise level
- lower lubricant demand
- longer grease operating life
- higher basic load ratings
- longer operating life of the bearings.

The basic dynamic load ratings C are up to approx. 20% higher than those of the previous bearing designs and the basic bearing rating life L_{10} is up to 65% longer than the previous standard. As a result of the increase in the basic bearing rating life L_{10} , this gives a longer operating life of the bearings under the same operating conditions. If the rating life values are maintained, alternatively, higher loads can be applied to the bearing arrangement.

1.4

Super precision axial bearings

Suitable for applications with very high precision and high axial loads

Super precision axial angular contact ball bearings 2344

Double direction axial angular contact ball bearings of series 2344 in particular are very axially rigid super precision bearings preloaded clearance-free with restricted tolerances to class SP. The bearings are used when very high precision is required under high axial load.



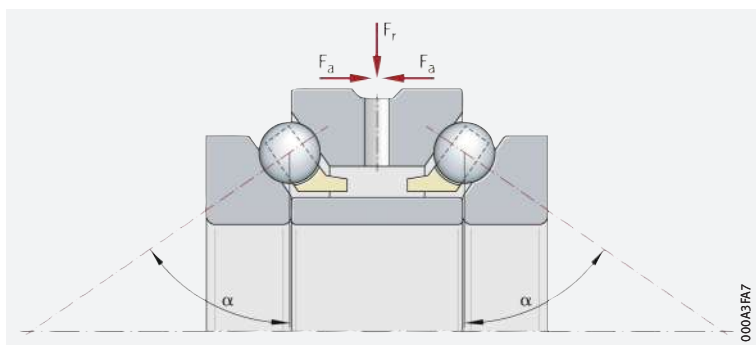

Axial angular contact ball bearing 2344, double direction

- α = nominal contact angle
- F_r = radial load
- F_a = axial load



Features

These bearings without self-retention comprise solid shaft locating washers, a spacer ring, a housing locating washer and ball and cage assemblies with solid cages [▶ 1176](#) | . The bearing parts are matched to each other and can be fitted separately, but must not be interchanged with parts from other bearings. Available designs of series 2344 [▶ 1262](#) | .

Contact angle

Due to the contact angle of 60°, they can support high axial loads from both sides.

☞ *Suitable for applications with high speeds and axial loads*

Super precision angular contact ball bearings BAX

Increased load carrying capacity normally brings with it a reduction in the maximum speed. Through the use of angular contact ball bearings BAX, it is possible to unify both requirements. Angular contact ball bearings BAX:

- can support high axial loads
- have similarly high limiting speeds to X-life cylindrical roller bearings
- have high rigidity
- can support axial loads only.

The super precision angular contact ball bearings BAX conform to the accuracy class P4S and are generally supplied as ready-to-fit sets in the arrangement DB ➤ 1177 | ☞ 4. Available designs ➤ 1264 | .



Angular contact ball bearing BAX, ready-to-fit set in O arrangement

α = nominal contact angle

F_a = axial load

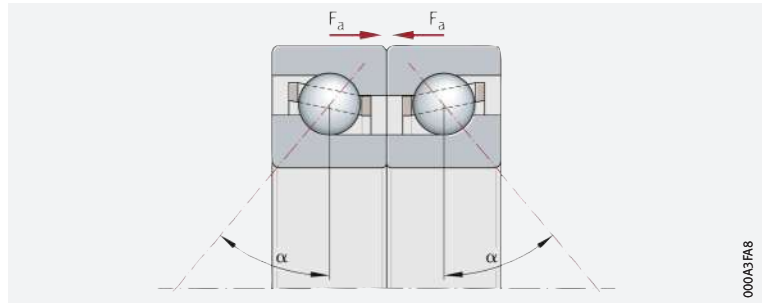

☞ *Contact angle*

Super precision angular contact ball bearings BAX are available with a contact angle of 30° for high speed requirements or, for even higher rigidities, also with a contact angle of 40° . As a bearing set, they can support high axial loads from both sides.





Super precision angular contact ball bearings

With large or small balls
Steel or ceramic balls
Steel or Cronidur rings
Open or sealed

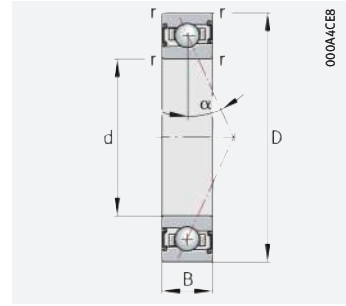
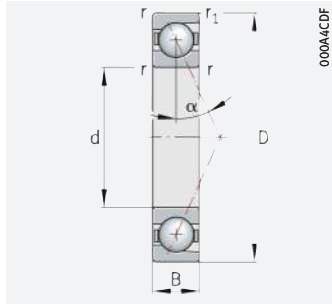

d = 10 – 10 mm

Main dimensions			Basic load ratings		Fatigue limit load C_{ur} N	Limiting speeds ¹⁾		Dimensions		Contact angle α °	Mass m ≈ kg	Designation ²⁾³⁾
d	D	B	dyn. C_r kN	stat. C_{0r} kN		n_G grease min ⁻¹	n_G oil ⁵⁾ min ⁻¹	r	r ₁			
10	22	6	2,9	1,02	105	70 000	110 000	0,3	0,3	25	0,01	B71900-E-T-P4S
	22	6	3	1,07	110	75 000	120 000	0,3	0,3	15	0,01	B71900-C-T-P4S
	22	6	2,9	0,98	75	95 000	150 000	0,3	0,3	25	0,009	HCB71900-E-T-P4S
	22	6	1,7	0,62	64	95 000	140 000	0,3	0,3	25	0,01	HS71900-E-T-P4S
	22	6	1,79	0,65	67	100 000	160 000	0,3	0,3	15	0,01	HS71900-C-T-P4S
	22	6	3	1,02	78	110 000	160 000	0,3	0,3	15	0,009	HCB71900-C-T-P4S
	22	6	1,7	0,6	45,5	120 000	180 000	0,3	0,3	25	0,01	HC71900-E-T-P4S
	22	6	2,6	0,6	45,5	130 000	200 000	0,3	0,3	25	0,01	XC71900-E-T-P4S
	26	8	3,95	1,41	145	60 000	95 000	0,3	0,3	25	0,02	B7000-E-T-P4S
	26	8	4,1	1,47	151	67 000	100 000	0,3	0,3	15	0,02	B7000-C-T-P4S
	26	8	3,95	1,35	102	85 000	130 000	0,3	0,3	25	0,018	HCB7000-E-T-P4S
	26	8	2,35	0,89	92	85 000	130 000	0,3	0,3	25	0,021	HS7000-E-T-P4S
	26	8	2,47	0,94	97	90 000	140 000	0,3	0,3	15	0,021	HS7000-C-T-P4S
	26	8	4,1	1,4	107	95 000	140 000	0,3	0,3	15	0,018	HCB7000-C-T-P4S
	26	8	2,35	0,86	65	110 000	160 000	0,3	0,3	25	0,021	HC7000-E-T-P4S
	26	8	3,6	0,86	65	120 000	180 000	0,3	0,3	25	0,021	XC7000-E-T-P4S
30	9	6,6	2,8	295	50 000	75 000	0,6	0,6	25	0,032	B7200-E-T-P4S	
30	9	6,9	2,95	305	56 000	85 000	0,6	0,6	15	0,032	B7200-C-T-P4S	
30	9	6,6	2,7	208	60 000	90 000	0,6	0,6	25	0,029	HCB7200-E-T-P4S	
30	9	6,9	2,8	217	67 000	100 000	0,6	0,6	15	0,029	HCB7200-C-T-P4S	

medias ► <https://www.schaeffler.de/std/1DB6>

- 1) The limiting speeds are based on elastically preloaded single bearings.
- 2) Explanation of designations ► [SP 1](#).
- 3) The bearings are also available with gap seals (type HSS, HCS, XCS or suffix 2RSD).
Ordering examples: B7000-C-2RSD-T-P4S-UL and HSS7000-E-T-P4S-UL.
- 4) L = light preload; M = moderate preload; H = high preload.
- 5) Minimal quantity oil lubrication.

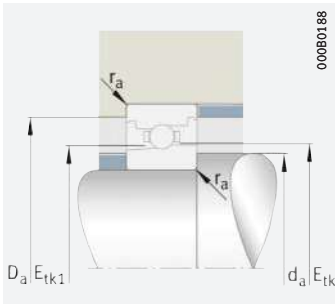

Mounting dimensions

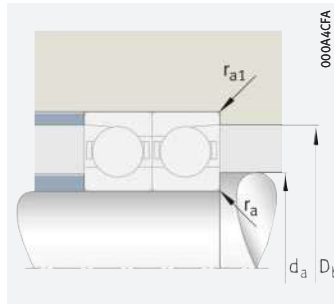

Mounting dimensions

d	Mounting dimensions							Preload force ⁴⁾ F _V			Lift-off force ⁴⁾ K _{aE}			Axial rigidity ⁴⁾ c _a		
	d _a h12	D _a H12	r _a max.	r _{a1} max.	E _{tk} min.	E _{tk1} min.	E _{tk} E _{tk1} max.	L	M	H	L	M	H	L	M	H
								N	N	N	N	N	N	N/μm	N/μm	N/μm
10	13	19,5	0,3	0,1	14,4	14,4	15	17	74	163	50	226	521	27,1	47,7	67
	13	19,5	0,3	0,1	14,4	14,4	15	10	41	87	31	141	320	11	21,1	31,2
	13	19,5	0,3	0,1	14,4	14,4	15	5	35	85	16	104	260	20,4	39,9	56,5
	13	19,5	0,3	0,1	14,6	13,7	15	11	32	64	31	96	196	21,7	32,7	43
	13	19,5	0,3	0,1	14,6	13,7	15	7	20	39	20	63	132	8,8	14,1	19,6
	13	19,5	0,3	0,1	14,4	14,4	15	6	25	54	17	79	185	9,8	18,2	26,5
	13	19,5	0,3	0,1	14,6	13,7	15	7	22	45	21	65	133	21,6	32	41,7
	13	19,5	0,3	0,1	14,6	13,7	15	7	22	45	21	65	133	21,6	32	41,7
	14	22	0,3	0,1	15,7	15,7	16,8	21	99	223	61	298	698	27,6	49,2	69,1
	14	22	0,3	0,1	15,7	15,7	16,8	18	65	136	54	220	490	12,7	23	33,5
	14	22	0,3	0,1	15,7	15,7	16,8	12	57	130	33	167	392	25,1	44,6	61,6
	14	22	0,3	0,1	16,4	15,3	16,9	15	45	90	43	133	273	26,8	40,3	53
	14	22	0,3	0,1	16,4	15,3	16,9	9	28	55	28	89	185	10,9	17,4	24,1
	14	22	0,3	0,1	15,7	15,7	16,8	7	33	74	21	104	248	9,9	18,5	26,9
	14	22	0,3	0,1	16,4	15,3	16,9	10	31	62	30	91	185	26,6	39,5	51,4
	14	22	0,3	0,1	16,4	15,3	16,9	10	31	62	30	91	185	26,6	39,5	51,4
	14,5	25,5	0,6	0,3	18	18	19,2	32	141	314	94	429	995	35,8	63,2	88,8
	14,5	25,5	0,6	0,3	18	18	19,2	25	91	185	79	311	684	16,4	29,8	43,5
	14,5	25,5	0,6	0,3	18	18	19,2	18	82	185	52	243	564	32,8	57,2	78,9
	14,5	25,5	0,6	0,3	18	18	19,2	11	47	103	32	150	352	12,9	23,9	34,9





Super precision angular contact ball bearings

With large or small balls
Steel or ceramic balls
Steel or Cronidur rings
Open or sealed

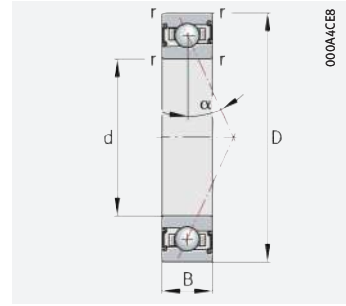
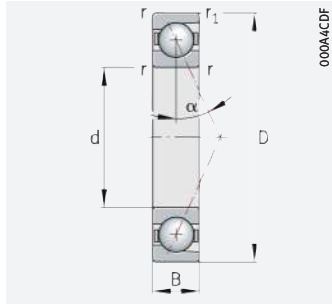

d = 12 – 12 mm

Main dimensions			Basic load ratings		Fatigue limit load C_{ur} N	Limiting speeds ¹⁾		Dimensions		Contact angle α °	Mass m ≈ kg	Designation ²⁾³⁾
d	D	B	dyn. C_r kN	stat. C_{0r} kN		n_G grease min ⁻¹	n_G oil ⁵⁾ min ⁻¹	r	r_1			
							min.	min.				
12	24	6	3,25	1,25	128	60 000	95 000	0,3	0,3	25	0,011	B71901-E-T-P4S
	24	6	3,4	1,31	135	67 000	100 000	0,3	0,3	15	0,011	B71901-C-T-P4S
	24	6	1,76	0,69	71	85 000	130 000	0,3	0,3	25	0,011	HS71901-E-T-P4S
	24	6	3,25	1,19	91	85 000	130 000	0,3	0,3	25	0,01	HCB71901-E-T-P4S
	24	6	1,85	0,72	74	90 000	140 000	0,3	0,3	15	0,011	HS71901-C-T-P4S
	24	6	3,4	1,25	95	95 000	140 000	0,3	0,3	15	0,01	HCB71901-C-T-P4S
	24	6	1,76	0,66	50	110 000	160 000	0,3	0,3	25	0,011	HC71901-E-T-P4S
	24	6	2,7	0,66	50	120 000	180 000	0,3	0,3	25	0,011	XC71901-E-T-P4S
	28	8	4,45	1,75	180	53 000	85 000	0,3	0,3	25	0,023	B7001-E-T-P4S
	28	8	4,65	1,83	188	60 000	90 000	0,3	0,3	15	0,023	B7001-C-T-P4S
	28	8	2,32	0,91	94	75 000	110 000	0,3	0,3	25	0,024	HS7001-E-T-P4S
	28	8	4,45	1,67	128	75 000	120 000	0,3	0,3	25	0,02	HCB7001-E-T-P4S
	28	8	2,45	0,96	99	80 000	130 000	0,3	0,3	15	0,024	HS7001-C-T-P4S
	28	8	4,65	1,75	133	85 000	130 000	0,3	0,3	15	0,02	HCB7001-C-T-P4S
	28	8	2,32	0,87	67	95 000	140 000	0,3	0,3	25	0,023	HC7001-E-T-P4S
	28	8	3,55	0,87	67	100 000	160 000	0,3	0,3	25	0,023	XC7001-E-T-P4S
32	10	8,8	3,75	385	45 000	67 000	0,6	0,6	25	0,037	B7201-E-T-P4S	
32	10	9,1	3,9	400	50 000	75 000	0,6	0,6	15	0,037	B7201-C-T-P4S	
32	10	8,8	3,6	275	56 000	85 000	0,6	0,6	25	0,032	HCB7201-E-T-P4S	
32	10	9,1	3,7	285	63 000	95 000	0,6	0,6	15	0,032	HCB7201-C-T-P4S	

medias ► <https://www.schaeffler.de/std/1DB7>

- 1) The limiting speeds are based on elastically preloaded single bearings.
- 2) Explanation of designations ► [SP 1](#).
- 3) The bearings are also available with gap seals (type HSS, HCS, XCS or suffix 2RSD).
Ordering examples: B7000-C-2RSD-T-P4S-UL and HSS7000-E-T-P4S-UL.
- 4) L = light preload; M = moderate preload; H = high preload.
- 5) Minimal quantity oil lubrication.

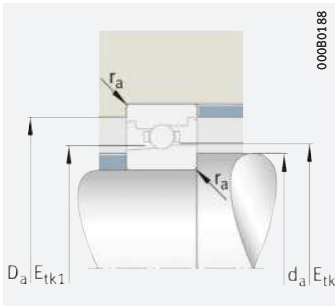

Mounting dimensions

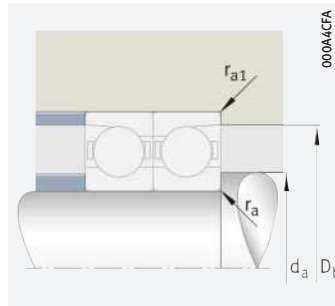

Mounting dimensions

d	Mounting dimensions							Preload force ⁴⁾ F _V			Lift-off force ⁴⁾ K _{aE}			Axial rigidity ⁴⁾ c _a		
	d _a h12	D _a H12	r _a	r _{a1}	E _{tk}	E _{tk1}	E _{tk} E _{tk1} max.	L	M	H	L	M	H	L	M	H
			max.	max.	min.	min.	max.	N	N	N	N	N	N	N/μm	N/μm	N/μm
12	15	21,5	0,3	0,1	16,4	16,4	17,2	18	80	179	53	245	567	30,8	54,4	76,5
	15	21,5	0,3	0,1	16,4	16,4	17,2	11	46	97	34	155	355	12,6	24,1	35,7
	15	21,5	0,3	0,1	16,6	15,7	17	11	33	67	32	99	203	23,1	34,7	45,6
	15	21,5	0,3	0,1	16,4	16,4	17,2	5	38	92	16	111	281	22,7	45,5	64,5
	15	21,5	0,3	0,1	16,6	15,7	17	7	21	41	21	66	137	9,4	15	20,8
	15	21,5	0,3	0,1	16,4	16,4	17,2	6	27	60	18	87	205	11,2	20,8	30,3
	15	21,5	0,3	0,1	16,6	15,7	17	8	23	46	22	68	138	22,9	34,1	44,3
	15	21,5	0,3	0,1	16,6	15,7	17	8	23	46	22	68	138	22,9	34,1	44,3
	16,5	24,5	0,3	0,1	17,9	17,9	18,8	23	109	248	66	328	775	31,8	57,2	80,3
	16,5	24,5	0,3	0,1	17,9	17,9	18,8	19	73	152	59	242	543	14,6	26,5	38,7
	16,5	24,5	0,3	0,1	18,4	17,3	18,9	15	44	88	43	131	268	26,7	40	52,6
	16,5	24,5	0,3	0,1	17,9	17,9	18,8	12	63	145	35	184	436	29	51,9	71,7
	16,5	24,5	0,3	0,1	18,4	17,3	18,9	9	27	54	27	87	181	10,8	17,3	23,9
	16,5	24,5	0,3	0,1	17,9	17,9	18,8	8	36	82	22	114	274	11,3	21,4	31,1
	16,5	24,5	0,3	0,1	18,4	17,3	18,9	10	30	61	29	89	181	26,4	39,2	50,9
	16,5	24,5	0,3	0,1	18,4	17,3	18,9	10	30	61	29	89	181	26,4	39,2	50,9
	16,5	27,5	0,6	0,3	19,6	19,6	21,1	47	193	423	137	588	1342	42,8	73,9	103
	16,5	27,5	0,6	0,3	19,6	19,6	21,1	35	123	248	109	420	916	19,3	34,6	50,3
	16,5	27,5	0,6	0,3	19,6	19,6	21,1	26	112	248	76	332	757	39,2	66,8	91,6
	16,5	27,5	0,6	0,3	19,6	19,6	21,1	16	65	142	47	210	483	15,6	28,2	40,9





Super precision angular contact ball bearings

With large or small balls
Steel or ceramic balls
Steel or Cronidur rings
Open or sealed

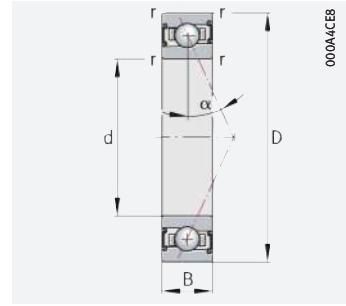
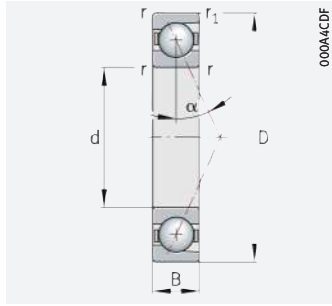

d = 15 – 15 mm

Main dimensions			Basic load ratings		Fatigue limit load C_{ur} N	Limiting speeds ¹⁾		Dimensions		Contact angle α °	Mass m ≈ kg	Designation ²⁾³⁾
d	D	B	dyn. C_r kN	stat. C_{0r} kN		n_G grease min ⁻¹	n_G oil ⁵⁾ min ⁻¹	r	r_1			
15	28	7	4,85	1,94	200	50 000	75 000	0,3	0,3	25	0,016	B71902-E-T-P4S
	28	7	5,1	2,03	209	56 000	85 000	0,3	0,3	15	0,016	B71902-C-T-P4S
	28	7	2,41	0,99	102	67 000	100 000	0,3	0,3	25	0,017	HS71902-E-T-P4S
	28	7	2,55	1,04	107	75 000	110 000	0,3	0,3	15	0,017	HS71902-C-T-P4S
	28	7	4,85	1,86	141	70 000	110 000	0,3	0,3	25	0,014	HCB71902-E-T-P4S
	28	7	5,1	1,94	148	75 000	120 000	0,3	0,3	15	0,014	HCB71902-C-T-P4S
	28	7	2,41	0,95	72	85 000	130 000	0,3	0,3	25	0,016	HC71902-E-T-P4S
	28	7	3,7	0,95	72	95 000	150 000	0,3	0,3	25	0,016	XC71902-E-T-P4S
	32	9	5,9	2,31	237	45 000	70 000	0,3	0,3	25	0,03	B7002-E-T-P4S
	32	9	6,1	2,41	248	53 000	80 000	0,3	0,3	15	0,03	B7002-C-T-P4S
	32	9	3,25	1,41	145	63 000	95 000	0,3	0,3	25	0,033	HS7002-E-T-P4S
	32	9	5,9	2,21	168	63 000	100 000	0,3	0,3	25	0,027	HCB7002-E-T-P4S
	32	9	3,45	1,48	152	70 000	110 000	0,3	0,3	15	0,033	HS7002-C-T-P4S
	32	9	6,1	2,31	176	70 000	110 000	0,3	0,3	15	0,027	HCB7002-C-T-P4S
	32	9	3,25	1,35	103	80 000	120 000	0,3	0,3	25	0,031	HC7002-E-T-P4S
	32	9	5	1,35	103	90 000	140 000	0,3	0,3	25	0,031	XC7002-E-T-P4S
	35	11	11,1	4,85	510	40 000	60 000	0,6	0,6	25	0,044	B7202-E-T-P4S
	35	11	11,6	5	520	45 000	67 000	0,6	0,6	15	0,044	B7202-C-T-P4S
	35	11	11,1	4,65	360	48 000	70 000	0,6	0,6	25	0,038	HCB7202-E-T-P4S
	35	11	11,6	4,8	370	56 000	85 000	0,6	0,6	15	0,038	HCB7202-C-T-P4S

medias ► <https://www.schaeffler.de/std/1DB8>

- 1) The limiting speeds are based on elastically preloaded single bearings.
- 2) Explanation of designations ► SP 1.
- 3) The bearings are also available with gap seals (type HSS, HCS, XCS or suffix 2RSD).
Ordering examples: B7000-C-2RSD-T-P4S-UL and HSS7000-E-T-P4S-UL.
- 4) L = light preload; M = moderate preload; H = high preload.
- 5) Minimal quantity oil lubrication.

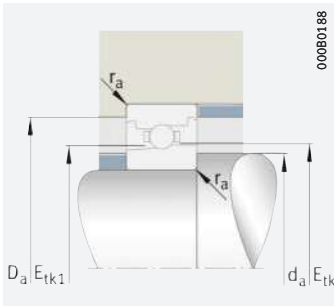

Mounting dimensions

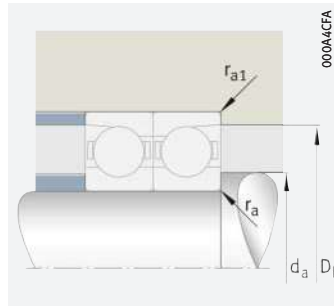

Mounting dimensions

d	Mounting dimensions							Preload force ⁴⁾ F _V			Lift-off force ⁴⁾ K _{aE}			Axial rigidity ⁴⁾ c _a		
	d _a h12	D _a H12	r _a	r _{a1}	E _{tk}	E _{tk1}	E _{tk} E _{tk1}	L	M	H	L	M	H	L	M	H
			max.	max.	min.	min.	max.	N	N	N	N	N	N	N/μm	N/μm	N/μm
15	18	25,5	0,3	0,1	19,9	19,9	20,9	22	111	255	64	336	805	35	64,7	91,9
	18	25,5	0,3	0,1	19,9	19,9	20,9	19	73	153	59	249	559	16,4	30,5	44,9
	18	25,5	0,3	0,1	19,9	18,8	20,4	15	46	91	44	136	278	28,3	42,4	55,6
	18	25,5	0,3	0,1	19,9	18,8	20,4	9	28	56	28	90	188	11,4	18,2	25,2
	18	25,5	0,3	0,1	19,9	19,9	20,9	12	64	150	34	190	457	31,9	58,7	82
	18	25,5	0,3	0,1	19,9	19,9	20,9	7	37	84	21	117	285	12,5	24,4	35,9
	18	25,5	0,3	0,1	19,9	18,8	20,4	11	32	63	30	92	188	28	41,5	53,9
	18	25,5	0,3	0,1	19,9	18,8	20,4	11	32	63	30	92	188	28	41,5	53,9
	19	29	0,3	0,1	21,1	21,1	22,3	36	154	341	104	464	1066	37,2	64,6	89,8
	19	29	0,3	0,1	21,1	21,1	22,3	27	99	204	84	332	733	16,6	29,7	43
	19	29	0,3	0,1	21,6	20,4	22,4	20	61	122	59	182	372	34	50,9	66,8
	19	29	0,3	0,1	21,1	21,1	22,3	20	88	199	57	260	600	34,1	58,6	80,2
	19	29	0,3	0,1	21,6	20,4	22,4	13	38	75	38	120	251	13,7	21,8	30,2
	19	29	0,3	0,1	21,1	21,1	22,3	12	52	114	35	164	381	13,4	24,3	35,1
	19	29	0,3	0,1	21,6	20,4	22,4	14	42	85	41	124	252	33,7	49,9	64,8
	19	29	0,3	0,1	21,6	20,4	22,4	14	42	85	41	124	252	33,7	49,9	64,8
	19,5	30,5	0,6	0,3	21,7	21,7	23,4	64	252	546	187	768	1732	49,7	84,4	117
	19,5	30,5	0,6	0,3	21,7	21,7	23,4	46	158	319	144	543	1177	22,1	39,3	57
	19,5	30,5	0,6	0,3	21,7	21,7	23,4	24	126	291	70	371	884	39,7	72	100
	19,5	30,5	0,6	0,3	21,7	21,7	23,4	22	86	183	65	275	626	18,1	32,3	46,5





Super precision angular contact ball bearings

With large or small balls
Steel or ceramic balls
Steel or Cronidur rings
Open or sealed

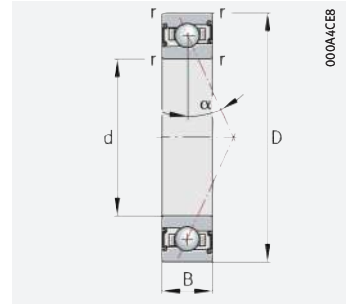
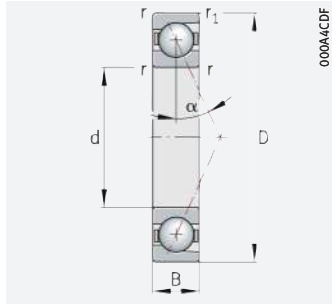

d = 17 – 17 mm

Main dimensions			Basic load ratings		Fatigue limit load C_{ur} N	Limiting speeds ¹⁾		Dimensions		Contact angle α °	Mass m ≈ kg	Designation ²⁾³⁾			
d	D	B	dyn. C_r kN	stat. C_{0r} kN		n_G grease min ⁻¹	n_G oil ⁵⁾ min ⁻¹	r	r_1						
												min.	min.		
17	30	7	5,1	2,12	219	45 000	70 000	0,3	0,3	25	0,018	B71903-E-T-P4S			
	30	7	5,3	2,23	229	50 000	80 000	0,3	0,3	15	0,018	B71903-C-T-P4S			
	30	7	2,48	1,07	110	63 000	95 000	0,3	0,3	25	0,019	HS71903-E-T-P4S			
	30	7	5,1	2,03	155	63 000	100 000	0,3	0,3	25	0,015	HCB71903-E-T-P4S			
	30	7	2,6	1,13	116	70 000	110 000	0,3	0,3	15	0,019	HS71903-C-T-P4S			
	30	7	5,3	2,13	162	70 000	110 000	0,3	0,3	15	0,015	HCB71903-C-T-P4S			
	30	7	2,48	1,03	78	80 000	120 000	0,3	0,3	25	0,018	HC71903-E-T-P4S			
	30	7	3,8	1,03	78	90 000	140 000	0,3	0,3	25	0,017	XC71903-E-T-P4S			
	35	10	8,2	3,35	345	43 000	63 000	0,3	0,3	25	0,039	B7003-E-T-P4S			
	35	10	8,6	3,5	360	45 000	70 000	0,3	0,3	15	0,039	B7003-C-T-P4S			
	35	10	3,35	1,52	157	56 000	85 000	0,3	0,3	25	0,04	HS7003-E-T-P4S			
	35	10	8,2	3,25	246	56 000	90 000	0,3	0,3	25	0,033	HCB7003-E-T-P4S			
	35	10	3,55	1,6	165	63 000	95 000	0,3	0,3	15	0,04	HS7003-C-T-P4S			
	35	10	8,6	3,35	255	63 000	100 000	0,3	0,3	15	0,033	HCB7003-C-T-P4S			
	35	10	3,35	1,46	111	75 000	110 000	0,3	0,3	25	0,038	HC7003-E-T-P4S			
	35	10	5,1	1,46	111	80 000	120 000	0,3	0,3	25	0,038	XC7003-E-T-P4S			
	40	12	12,4	5,6	580	36 000	53 000	0,6	0,6	25	0,062	B7203-E-T-P4S			
	40	12	13	5,8	600	38 000	56 000	0,6	0,6	15	0,063	B7203-C-T-P4S			
	40	12	12,4	5,4	410	43 000	63 000	0,6	0,6	25	0,055	HCB7203-E-T-P4S			
	40	12	13	5,6	425	50 000	75 000	0,6	0,6	15	0,056	HCB7203-C-T-P4S			

medias ► <https://www.schaeffler.de/std/1DB9>

- 1) The limiting speeds are based on elastically preloaded single bearings.
- 2) Explanation of designations ► [SP 1](#).
- 3) The bearings are also available with gap seals (type HSS, HCS, XCS or suffix 2RSD).
Ordering examples: B7000-C-2RSD-T-P4S-UL and HSS7000-E-T-P4S-UL.
- 4) L = light preload; M = moderate preload; H = high preload.
- 5) Minimal quantity oil lubrication.

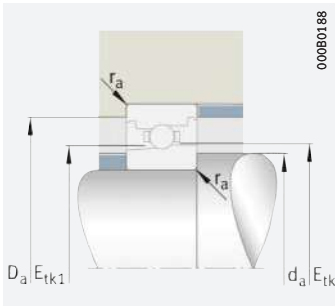

Mounting dimensions

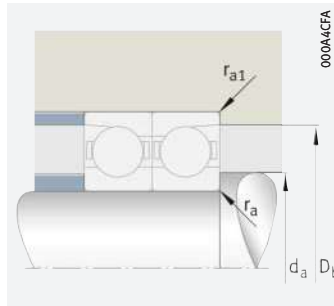

Mounting dimensions

d	Mounting dimensions							Preload force ⁴⁾ F _V			Lift-off force ⁴⁾ K _{aE}			Axial rigidity ⁴⁾ c _a		
	d _a h12	D _a H12	r _a	r _{a1}	E _{tk}	E _{tk1}	E _{tk} E _{tk1}	L	M	H	L	M	H	L	M	H
			max.	max.	min.	min.	max.	N	N	N	N	N	N	N/μm	N/μm	N/μm
17	20	27,5	0,3	0,1	21,4	21,4	22,3	22	115	265	65	346	833	36,9	68,5	97,3
	20	27,5	0,3	0,1	21,4	21,4	22,3	20	78	162	62	263	592	17,5	32,6	47,9
	20	27,5	0,3	0,1	21,9	20,8	22,4	16	47	93	45	138	283	29,6	44,4	58,3
	20	27,5	0,3	0,1	21,4	21,4	22,3	12	65	154	34	193	466	33,4	61,9	86,4
	20	27,5	0,3	0,1	21,9	20,8	22,4	10	29	58	29	93	194	12	19,2	26,5
	20	27,5	0,3	0,1	21,4	21,4	22,3	8	39	89	22	123	300	13,3	26	38,3
	20	27,5	0,3	0,1	21,9	20,8	22,4	11	33	66	31	96	195	29,6	43,9	56,9
	20	27,5	0,3	0,1	21,9	20,8	22,4	11	33	66	31	96	195	29,6	43,9	56,9
	21	32	0,3	0,1	23,3	23,3	24,5	54	220	483	156	663	1 504	47,6	81	112
	21	32	0,3	0,1	23,3	23,3	24,5	40	142	291	124	474	1 042	21,1	37,1	53,6
	21	32	0,3	0,1	24,1	22,9	24,8	21	63	126	61	187	382	35,7	53,4	70
	21	32	0,3	0,1	23,3	23,3	24,5	30	126	279	85	370	840	43,5	73,4	99,7
	21	32	0,3	0,1	24,1	22,9	24,8	13	38	76	38	121	253	14,3	22,7	31,3
	21	32	0,3	0,1	23,3	23,3	24,5	18	75	164	54	237	546	17,3	30,7	43,9
	21	32	0,3	0,1	24,1	22,9	24,8	14	43	86	41	126	256	35,3	52,2	67,7
	21	32	0,3	0,1	24,1	22,9	24,8	14	43	86	41	126	256	35,3	52,2	67,7
	22,5	34,5	0,6	0,3	25	25	26,7	74	286	616	216	871	1 954	53,3	89,9	125
	22,5	34,5	0,6	0,3	25	25	26,7	53	179	360	165	614	1 327	23,6	41,8	60,6
	22,5	34,5	0,6	0,3	25	25	26,7	29	145	332	84	428	1 011	43,2	77,2	107
	22,5	34,5	0,6	0,3	25	25	26,7	25	97	208	75	313	708	19,5	34,4	49,5





Super precision angular contact ball bearings

With large or small balls
Steel or ceramic balls
Steel or Cronidur rings
Open or sealed

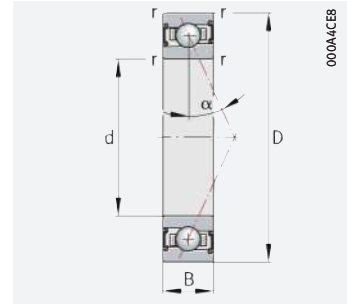
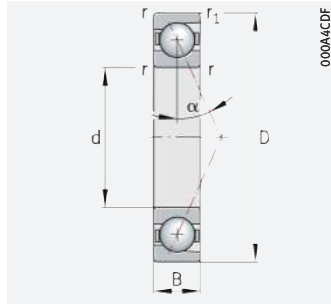

d = 20 – 20 mm

Main dimensions			Basic load ratings		Fatigue limit load C_{ur} N	Limiting speeds ¹⁾		Dimensions		Contact angle α °	Mass m ≈ kg	Designation ²⁾³⁾
d	D	B	dyn. C_r kN	stat. C_{0r} kN		n_G grease min ⁻¹	n_G oil ⁵⁾ min ⁻¹	r	r ₁			
20	37	9	7	3,05	315	38 000	60 000	0,3	0,3	25	0,037	B71904-E-T-P4S
	37	9	7,4	3,2	330	43 000	63 000	0,3	0,3	15	0,037	B71904-C-T-P4S
	37	9	3,4	1,63	168	53 000	80 000	0,3	0,3	25	0,04	HS71904-E-T-P4S
	37	9	7	2,95	223	53 000	80 000	0,3	0,3	25	0,033	HCB71904-E-T-P4S
	37	9	3,6	1,73	178	56 000	90 000	0,3	0,3	15	0,04	HS71904-C-T-P4S
	37	9	7,4	3,1	234	60 000	90 000	0,3	0,3	15	0,033	HCB71904-C-T-P4S
	37	9	3,4	1,56	119	67 000	100 000	0,3	0,3	25	0,039	HC71904-E-T-P4S
	37	9	5,2	1,56	119	75 000	110 000	0,3	0,3	25	0,038	XC71904-E-T-P4S
	42	12	9,8	4,05	415	34 000	53 000	0,6	0,6	25	0,067	B7004-E-T-P4S
	42	12	10,3	4,25	435	38 000	60 000	0,6	0,6	15	0,067	B7004-C-T-P4S
	42	12	5,4	2,6	265	48 000	75 000	0,6	0,6	25	0,077	HS7004-E-T-P4S
	42	12	9,8	3,9	295	48 000	75 000	0,6	0,6	25	0,061	HCB7004-E-T-P4S
	42	12	5,7	2,7	280	53 000	80 000	0,6	0,6	15	0,077	HS7004-C-T-P4S
	42	12	10,3	4,05	310	53 000	80 000	0,6	0,6	15	0,061	HCB7004-C-T-P4S
	42	12	5,4	2,47	188	60 000	95 000	0,6	0,6	25	0,073	HC7004-E-T-P4S
	42	12	8,3	2,47	188	67 000	100 000	0,6	0,6	25	0,073	XC7004-E-T-P4S
	47	14	16,5	7,7	790	30 000	45 000	1	1	25	0,103	B7204-E-T-P4S
	47	14	17,2	8	820	32 000	48 000	1	1	15	0,103	B7204-C-T-P4S
	47	14	16,5	7,3	560	36 000	53 000	1	1	25	0,091	HCB7204-E-T-P4S
	47	14	17,2	7,6	580	40 000	60 000	1	1	15	0,092	HCB7204-C-T-P4S

medias ► <https://www.schaeffler.de/std/1DBA>

- 1) The limiting speeds are based on elastically preloaded single bearings.
- 2) Explanation of designations ► SP 1.
- 3) The bearings are also available with gap seals (type HSS, HCS, XCS or suffix 2RSD).
Ordering examples: B7000-C-2RSD-T-P4S-UL and HSS7000-E-T-P4S-UL.
- 4) L = light preload; M = moderate preload; H = high preload.
- 5) Minimal quantity oil lubrication.

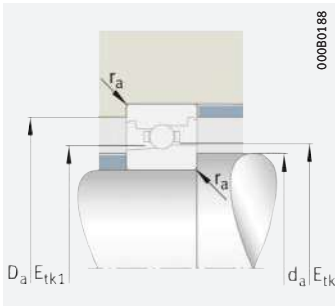

Mounting dimensions

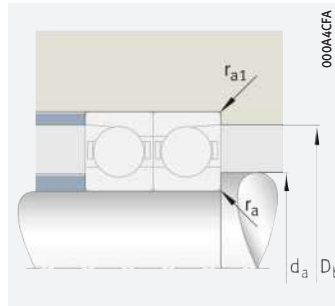

Mounting dimensions

d	Mounting dimensions							Preload force ⁴⁾ F _V			Lift-off force ⁴⁾ K _{aE}			Axial rigidity ⁴⁾ c _a		
	d _a h12	D _a H12	r _a max.	r _{a1} max.	E _{tk} min.	E _{tk1} min.	E _{tk} E _{tk1} max.	L	M	H	L	M	H	L	M	H
										N	N	N	N	N	N	N
20	24	33,5	0,3	0,15	26	26	27,1	37	170	384	108	516	1 208	46,7	83,3	117
	24	33,5	0,3	0,15	26	26	27,1	31	113	233	95	384	851	21,6	39,3	57,4
	24	33,5	0,3	0,15	26,6	25,4	27,2	22	65	129	62	191	392	37,4	55,9	73,2
	24	33,5	0,3	0,15	26	26	27,1	20	98	223	58	289	678	42,5	75,3	104
	24	33,5	0,3	0,15	26,6	25,4	27,2	13	39	78	39	124	259	15	23,7	32,7
	24	33,5	0,3	0,15	26	26	27,1	12	57	128	37	182	431	16,8	31,5	46
	24	33,5	0,3	0,15	26,6	25,4	27,2	15	44	88	42	128	261	36,9	54,6	70,7
	24	33,5	0,3	0,15	26,6	25,4	27,2	15	44	88	42	128	261	36,9	54,6	70,7
	25	37	0,6	0,3	27,8	27,8	29,3	71	275	595	205	829	1 857	51,6	86,3	119
	25	37	0,6	0,3	27,8	27,8	29,3	51	175	356	157	586	1 276	22,6	39,4	56,8
	25	37	0,6	0,3	28,6	27,1	29,7	34	101	202	97	299	611	49,1	73,6	96,4
	25	37	0,6	0,3	27,8	27,8	29,3	28	140	321	80	410	966	42	74,7	103
	25	37	0,6	0,3	28,6	27,1	29,7	21	62	125	63	198	413	19,8	31,5	43,5
	25	37	0,6	0,3	27,8	27,8	29,3	24	94	202	72	297	673	18,7	32,7	46,6
	25	37	0,6	0,3	28,6	27,1	29,7	23	70	140	67	204	415	48,8	72,3	93,7
	25	37	0,6	0,3	28,6	27,1	29,7	23	70	140	67	204	415	48,8	72,3	93,7
	26,5	40,5	1	0,3	29,6	29,6	31,7	107	398	848	313	1 212	2 686	63,7	106	146
	26,5	40,5	1	0,3	29,6	29,6	31,7	75	248	496	234	851	1 828	28,1	49,3	71,1
	26,5	40,5	1	0,3	29,6	29,6	31,7	46	205	460	131	606	1 400	53	91,6	126
	26,5	40,5	1	0,3	29,6	29,6	31,7	36	135	284	109	432	967	23,3	40,5	57,9





Super precision angular contact ball bearings

With large or small balls
Steel or ceramic balls
Steel or Cronidur rings
Open or sealed

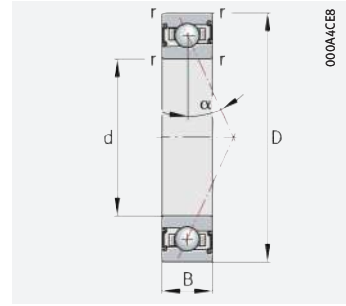
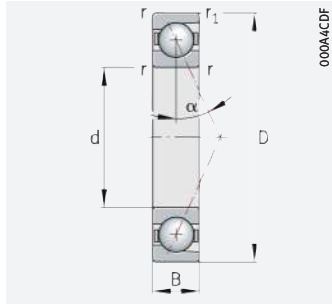

d = 25 – 25 mm

Main dimensions			Basic load ratings		Fatigue limit load C_{ur} N	Limiting speeds ¹⁾		Dimensions		Contact angle α °	Mass m ≈ kg	Designation ²⁾³⁾
d	D	B	dyn. C_r kN	stat. C_{0r} kN		n_G grease min^{-1}	n_G oil ⁵⁾ min^{-1}	r	r_1			
							min.	min.				
25	42	9	7,6	3,6	370	32 000	50 000	0,3	0,3	25	0,043	B71905-E-T-P4S
	42	9	8	3,8	390	36 000	56 000	0,3	0,3	15	0,043	B71905-C-T-P4S
	42	9	3,65	1,95	201	43 000	67 000	0,3	0,3	25	0,046	HS71905-E-T-P4S
	42	9	7,6	3,45	265	45 000	67 000	0,3	0,3	25	0,039	HCB71905-E-T-P4S
	42	9	3,9	2,06	212	48 000	75 000	0,3	0,3	15	0,046	HS71905-C-T-P4S
	42	9	8	3,65	275	50 000	75 000	0,3	0,3	15	0,039	HCB71905-C-T-P4S
	42	9	3,65	1,87	142	56 000	85 000	0,3	0,3	25	0,045	HC71905-E-T-P4S
	42	9	5,6	1,87	142	63 000	95 000	0,3	0,3	25	0,044	XC71905-E-T-P4S
	47	12	13,1	5,6	580	30 000	45 000	0,6	0,6	25	0,077	B7005-E-T-P4S
	47	12	13,7	5,9	610	34 000	50 000	0,6	0,6	15	0,077	B7005-C-T-P4S
	47	12	13,1	5,4	410	40 000	63 000	0,6	0,6	25	0,065	HCB7005-E-T-P4S
	47	12	5,5	2,8	285	40 000	63 000	0,6	0,6	25	0,087	HS7005-E-T-P4S
	47	12	13,7	5,6	430	45 000	70 000	0,6	0,6	15	0,065	HCB7005-C-T-P4S
	47	12	5,8	2,95	305	45 000	70 000	0,6	0,6	15	0,087	HS7005-C-T-P4S
	47	12	5,5	2,65	203	53 000	80 000	0,6	0,6	25	0,084	HC7005-E-T-P4S
	47	12	8,4	2,65	203	56 000	90 000	0,6	0,6	25	0,084	XC7005-E-T-P4S
	52	15	14,2	5,8	600	26 000	40 000	1	1	25	0,127	B7205-E-T-P4S
	52	15	14,8	6,1	630	28 000	43 000	1	1	15	0,127	B7205-C-T-P4S
52	15	14,2	5,6	425	32 000	48 000	1	1	25	0,114	HCB7205-E-T-P4S	
52	15	14,8	5,8	445	36 000	53 000	1	1	15	0,114	HCB7205-C-T-P4S	

medias ► <https://www.schaeffler.de/std/1DDB>

- The limiting speeds are based on elastically preloaded single bearings.
- Explanation of designations ► [SP 1](#).
- The bearings are also available with gap seals (type HSS, HCS, XCS or suffix 2RSD).
Ordering examples: B7000-C-2RSD-T-P4S-UL and HSS7000-E-T-P4S-UL.
- L = light preload; M = moderate preload; H = high preload.
- Minimal quantity oil lubrication.

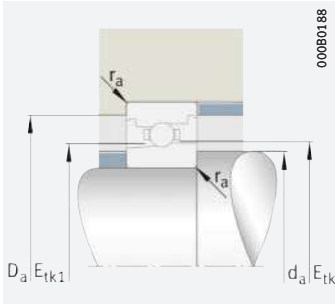

Mounting dimensions

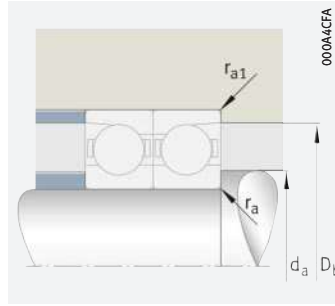

Mounting dimensions

d	Mounting dimensions							Preload force ⁴⁾ F _V			Lift-off force ⁴⁾ K _{aE}			Axial rigidity ⁴⁾ c _a		
	d _a h12	D _a H12	r _a max.	r _{a1} max.	E _{tk} min.	E _{tk1} min.	E _{tk} E _{tk1} max.	L	M	H	L	M	H	L	M	H
								N	N	N	N	N	N	N/μm	N/μm	N/μm
25	29	38,5	0,3	0,15	31	31	32	41	191	432	115	566	1335	54,1	97,3	137
	29	38,5	0,3	0,15	31	31	32	34	127	265	102	418	934	24,9	45,4	66,3
	29	38,5	0,3	0,15	31,6	30,4	32,2	23	69	138	66	204	416	42,2	63,1	82,4
	29	38,5	0,3	0,15	31	31	32	22	107	246	60	310	735	48,7	87,4	121
	29	38,5	0,3	0,15	31,6	30,4	32,2	14	43	85	43	135	282	17	26,8	36,9
	29	38,5	0,3	0,15	31	31	32	14	65	145	39	199	475	19,4	36,6	53,4
	29	38,5	0,3	0,15	31,6	30,4	32,2	16	47	95	45	138	281	41,8	61,9	80,1
	29	38,5	0,3	0,15	31,6	30,4	32,2	16	47	95	45	138	281	41,8	61,9	80,1
	30	42	0,6	0,3	32,5	32,5	34,1	99	381	820	290	1150	2560	67,2	112	153
	30	42	0,6	0,3	32,5	32,5	34,1	73	248	502	226	831	1807	29,6	51,2	73,5
	30	42	0,6	0,3	32,5	32,5	34,1	40	194	443	117	573	1338	55,4	96,9	133
	30	42	0,6	0,3	33,6	32,2	34,5	35	104	207	100	306	626	51,2	76,7	100
	30	42	0,6	0,3	32,5	32,5	34,1	35	132	283	104	419	944	24,6	42,5	60,2
	30	42	0,6	0,3	33,6	32,2	34,5	21	63	127	64	201	419	20,6	32,7	45
	30	42	0,6	0,3	33,6	32,2	34,5	23	70	140	67	204	415	50,4	74,7	96,7
	30	42	0,6	0,3	33,6	32,2	34,5	23	70	140	67	204	415	50,4	74,7	96,7
	31,5	45,5	1	0,3	34,4	34,4	36,5	116	429	914	333	1293	2868	69,2	115	159
	31,5	45,5	1	0,3	34,4	34,4	36,5	81	269	542	248	906	1949	30,4	53,4	77
	31,5	45,5	1	0,3	34,4	34,4	36,5	50	223	500	140	650	1504	57,6	99,8	137
	31,5	45,5	1	0,3	34,4	34,4	36,5	40	147	311	117	465	1042	25,3	44,1	63,1





Super precision angular contact ball bearings

With large or small balls
Steel or ceramic balls
Steel or Cronidur rings
Open or sealed

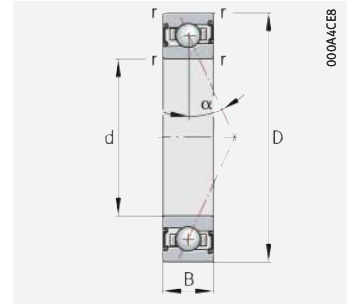
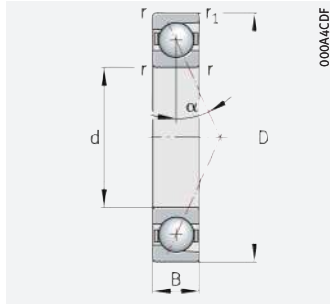

d = 30 – 30 mm

Main dimensions			Basic load ratings		Fatigue limit load C_{ur} N	Limiting speeds ¹⁾		Dimensions		Contact angle α °	Mass m ≈ kg	Designation ²⁾³⁾
d	D	B	dyn. C_r kN	stat. C_{Or} kN		n_G grease min ⁻¹	n_G oil ⁵⁾ min ⁻¹	r	r ₁			
30	47	9	8,1	4,15	425	28 000	43 000	0,3	0,3	25	0,05	B71906-E-T-P4S
	47	9	8,5	4,35	450	30 000	48 000	0,3	0,3	15	0,05	B71906-C-T-P4S
	47	9	8,1	3,95	300	38 000	60 000	0,3	0,3	25	0,045	HCB71906-E-T-P4S
	47	9	5,6	2,95	305	38 000	60 000	0,3	0,3	25	0,05	HS71906-E-T-P4S
	47	9	8,5	4,2	320	43 000	67 000	0,3	0,3	15	0,045	HCB71906-C-T-P4S
	47	9	5,9	3,1	320	43 000	63 000	0,3	0,3	15	0,05	HS71906-C-T-P4S
	47	9	5,6	2,85	215	48 000	75 000	0,3	0,3	25	0,046	HC71906-E-T-P4S
	47	9	8,5	2,85	215	53 000	85 000	0,3	0,3	25	0,046	XC71906-E-T-P4S
	55	13	13,7	6,4	660	24 000	38 000	1	1	25	0,114	B7006-E-T-P4S
	55	13	14,4	6,7	690	28 000	43 000	1	1	15	0,114	B7006-C-T-P4S
	55	13	13,7	6,1	465	34 000	53 000	1	1	25	0,101	HCB7006-E-T-P4S
	55	13	7,8	4,05	415	34 000	53 000	1	1	25	0,124	HS7006-E-T-P4S
	55	13	14,4	6,4	485	38 000	60 000	1	1	15	0,101	HCB7006-C-T-P4S
	55	13	8,2	4,25	435	38 000	56 000	1	1	15	0,124	HS7006-C-T-P4S
	55	13	7,8	3,85	295	43 000	67 000	1	1	25	0,119	HC7006-E-T-P4S
	55	13	12	3,85	295	48 000	75 000	1	1	25	0,119	XC7006-E-T-P4S
	62	16	22,1	9,9	1020	22 000	36 000	1	1	25	0,197	B7206-E-T-P4S
	62	16	23,1	10,4	1070	24 000	38 000	1	1	15	0,197	B7206-C-T-P4S
	62	16	22,1	9,5	720	26 000	40 000	1	1	25	0,172	HCB7206-E-T-P4S
	62	16	23,1	9,9	760	30 000	45 000	1	1	15	0,172	HCB7206-C-T-P4S

medias ► <https://www.schaeffler.de/std/1DBC>

- 1) The limiting speeds are based on elastically preloaded single bearings.
- 2) Explanation of designations ► SP 1.
- 3) The bearings are also available with gap seals (type HSS, HCS, XCS or suffix 2RSD).
Ordering examples: B7000-C-2RSD-T-P4S-UL and HSS7000-E-T-P4S-UL.
- 4) L = light preload; M = moderate preload; H = high preload.
- 5) Minimal quantity oil lubrication.

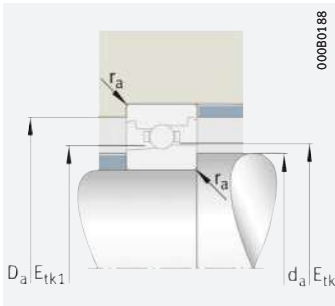

Mounting dimensions

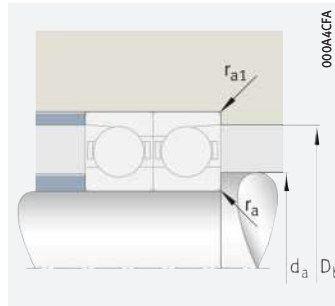

Mounting dimensions

d	Mounting dimensions							Preload force ⁴⁾ F _V			Lift-off force ⁴⁾ K _{aE}			Axial rigidity ⁴⁾ c _a		
	d _a h12	D _a H12	r _a max.	r _{a1} max.	E _{tk} min.	E _{tk1} min.	E _{tk} E _{tk1} max.	L	M	H	L	M	H	L	M	H
								N	N	N	N	N	N	N/μm	N/μm	N/μm
30	34	43,5	0,3	0,15	36	36	37	41	197	448	114	580	1 377	58	105	148
	34	43,5	0,3	0,15	36	36	37	36	134	281	106	439	985	27	49,3	72,1
	34	43,5	0,3	0,15	36	36	37	22	112	258	60	322	768	52,5	95,1	132
	34	43,5	0,3	0,15	36,1	34,7	37	35	104	207	100	306	625	52,9	79,1	103
	34	43,5	0,3	0,15	36	36	37	14	68	155	40	210	504	21,1	40	58,3
	34	43,5	0,3	0,15	36,1	34,7	37	21	64	129	65	204	425	21,3	33,8	46,5
	34	43,5	0,3	0,15	36,1	34,7	37	24	72	143	69	209	425	52,5	77,7	101
	34	43,5	0,3	0,15	36,1	34,7	37	24	72	143	69	209	425	52,5	77,7	101
	36	49	1	0,3	39,4	39,4	40,6	102	396	854	294	1 188	2 661	73,5	123	170
	36	49	1	0,3	39,4	39,4	40,6	74	254	516	228	848	1 844	32,4	56,7	81,8
	36	49	1	0,3	39,4	39,4	40,6	42	203	465	117	592	1 395	60,1	107	147
	36	49	1	0,3	39,7	37,9	40,9	48	143	286	138	423	865	60,6	90,6	119
	36	49	1	0,3	39,4	39,4	40,6	35	137	293	104	431	976	26,9	47	67,1
	36	49	1	0,3	39,7	37,9	40,9	29	88	177	89	280	584	24,4	38,7	53,2
	36	49	1	0,3	39,7	37,9	40,9	33	98	197	94	287	583	60	88,8	115
	36	49	1	0,3	39,7	37,9	40,9	33	98	197	94	287	583	60	88,8	115
	37,5	54,5	1	0,3	41,2	41,2	43,7	177	641	1 355	518	1 946	4 271	90,4	148	203
	37,5	54,5	1	0,3	41,2	41,2	43,7	123	404	806	385	1 375	2 945	39,6	68,8	98,9
	37,5	54,5	1	0,3	41,2	41,2	43,7	80	339	749	231	1 001	2 273	76,8	130	177
	37,5	54,5	1	0,3	41,2	41,2	43,7	62	222	465	185	711	1 576	33,3	57,1	81,1





Super precision angular contact ball bearings

With large or small balls
Steel or ceramic balls
Steel or Cronidur rings
Open or sealed

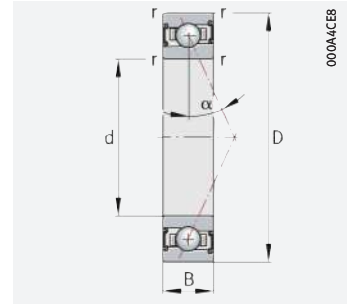
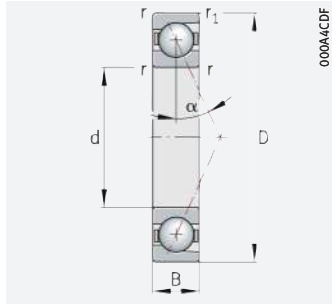

d = 35 – 35 mm

Main dimensions	Basic load ratings		Fatigue limit load		Limiting speeds ¹⁾		Dimensions		Contact angle	Mass	Designation ²⁾³⁾	
					C _{ur}	n _{G grease}	n _{G oil} ⁵⁾	r				r ₁
35	55	10	11,5	6,5	660	24 000	36 000	0,6	0,6	25	0,077	B71907-E-T-P4S
	55	10	12,1	6,8	700	26 000	40 000	0,6	0,6	15	0,077	B71907-C-T-P4S
	55	10	6,1	3,6	370	32 000	50 000	0,6	0,6	25	0,081	HS71907-E-T-P4S
	55	10	11,5	6,2	470	32 000	50 000	0,6	0,6	25	0,067	HCB71907-E-T-P4S
	55	10	6,4	3,8	390	36 000	56 000	0,6	0,6	15	0,081	HS71907-C-T-P4S
	55	10	12,1	6,5	495	36 000	56 000	0,6	0,6	15	0,067	HCB71907-C-T-P4S
	55	10	6,1	3,45	260	40 000	63 000	0,6	0,6	25	0,076	HC71907-E-T-P4S
	55	10	9,3	3,45	260	45 000	70 000	0,6	0,6	25	0,076	XC71907-E-T-P4S
	62	14	18,4	9,2	940	22 000	34 000	1	1	25	0,154	B7007-E-T-P4S
	62	14	19,3	9,6	990	24 000	38 000	1	1	15	0,154	B7007-C-T-P4S
	62	14	8,4	4,7	485	30 000	45 000	1	1	25	0,169	HS7007-E-T-P4S
	62	14	18,4	8,8	670	30 000	45 000	1	1	25	0,135	HCB7007-E-T-P4S
	62	14	8,9	5	510	34 000	50 000	1	1	15	0,169	HS7007-C-T-P4S
	62	14	19,3	9,2	700	34 000	53 000	1	1	15	0,135	HCB7007-C-T-P4S
	62	14	8,4	4,5	345	38 000	60 000	1	1	25	0,163	HC7007-E-T-P4S
	62	14	12,8	4,5	345	43 000	67 000	1	1	25	0,163	XC7007-E-T-P4S
	72	17	24,5	12,1	1 240	19 000	32 000	1,1	1,1	25	0,3	B7207-E-T-P4S
	72	17	25,5	12,6	1 300	20 000	34 000	1,1	1,1	15	0,301	B7207-C-T-P4S
	72	17	24,5	11,6	880	22 000	36 000	1,1	1,1	25	0,264	HCB7207-E-T-P4S
	72	17	25,5	12,1	920	26 000	40 000	1,1	1,1	15	0,265	HCB7207-C-T-P4S

medias ► <https://www.schaeffler.de/std/1DBD>

- 1) The limiting speeds are based on elastically preloaded single bearings.
- 2) Explanation of designations ► [SP 1](#).
- 3) The bearings are also available with gap seals (type HSS, HCS, XCS or suffix 2RSD).
Ordering examples: B7000-C-2RSD-T-P4S-UL and HSS7000-E-T-P4S-UL.
- 4) L = light preload; M = moderate preload; H = high preload.
- 5) Minimal quantity oil lubrication.

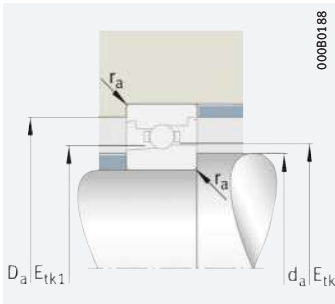

Mounting dimensions

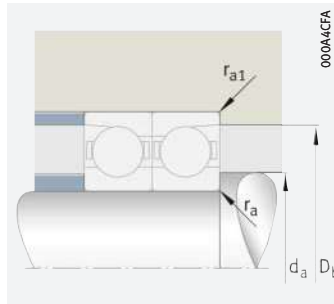

Mounting dimensions

d	Mounting dimensions							Preload force ⁴⁾ F _V			Lift-off force ⁴⁾ K _{aE}			Axial rigidity ⁴⁾ c _a		
	d _a h12	D _a H12	r _a	r _{a1}	E _{tk}	E _{tk1}	E _{tk} E _{tk1}	L	M	H	L	M	H	L	M	H
			max.	max.	min.	min.	max.	N	N	N	N	N	N	N/μm	N/μm	N/μm
35	40	51,5	0,6	0,15	42,6	42,6	44	60	273	613	174	820	1910	72,9	129	179
	40	51,5	0,6	0,15	42,6	42,6	44	50	185	384	155	619	1377	33,5	60,2	87,5
	40	51,5	0,6	0,15	42,6	41,2	43,4	38	113	226	109	333	680	61	91,1	119
	40	51,5	0,6	0,15	42,6	42,6	44	33	158	359	95	463	1081	66,7	117	161
	40	51,5	0,6	0,15	42,6	41,2	43,4	23	70	140	70	220	459	24,5	38,6	53
	40	51,5	0,6	0,15	42,6	42,6	44	21	96	213	63	301	709	26,7	49,1	71
	40	51,5	0,6	0,15	42,6	41,2	43,4	26	78	155	74	226	459	60,5	89,4	116
	40	51,5	0,6	0,15	42,6	41,2	43,4	26	78	155	74	226	459	60,5	89,4	116
	41	56	1	0,3	44,5	44,5	46,3	134	511	1097	394	1551	3446	87,9	146	200
	41	56	1	0,3	44,5	44,5	46,3	95	321	649	296	1087	2357	38,3	66,6	95,8
	41	56	1	0,3	45,7	43,9	46,8	51	152	304	146	448	915	67,7	101	132
	41	56	1	0,3	44,5	44,5	46,3	54	257	585	157	761	1771	72,1	126	173
	41	56	1	0,3	45,7	43,9	46,8	31	93	187	94	295	614	27,1	42,8	58,8
	41	56	1	0,3	44,5	44,5	46,3	46	175	372	138	558	1255	32	55,5	78,9
	41	56	1	0,3	45,7	43,9	46,8	35	105	210	101	307	623	67,3	99,5	129
	41	56	1	0,3	45,7	43,9	46,8	35	105	210	101	307	623	67,3	99,5	129
	44	63	1	0,3	47,8	47,8	51	195	710	1504	570	2152	4730	103	169	232
	44	63	1	0,3	47,8	47,8	51	134	443	887	418	1500	3223	44,8	77,8	112
	44	63	1	0,3	47,8	47,8	51	84	363	806	242	1069	2438	86,2	146	200
	44	63	1	0,3	47,8	47,8	51	67	243	510	200	774	1720	37,7	64,7	91,8





Super precision angular contact ball bearings

With large or small balls
Steel or ceramic balls
Steel or Cronidur rings
Open or sealed

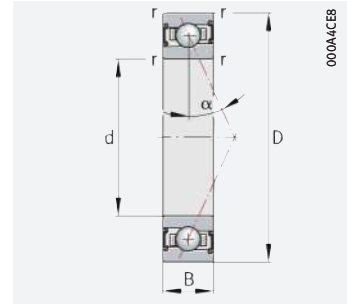
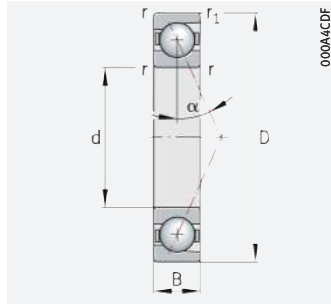

d = 40 – 40 mm

Main dimensions	Basic load ratings		Fatigue limit load		Limiting speeds ¹⁾		Dimensions		Contact angle	Mass	Designation ²⁾³⁾	
					C _{ur}	n _G grease	n _G oil ⁵⁾	r				r ₁
40	62	12	17,1	9,4	970	20 000	32 000	0,6	0,6	25	0,109	B71908-E-T-P4S
	62	12	18	9,9	1 020	24 000	36 000	0,6	0,6	15	0,109	B71908-C-T-P4S
	62	12	6,4	4,05	420	28 000	43 000	0,6	0,6	25	0,125	HS71908-E-T-P4S
	62	12	17,1	9	680	28 000	45 000	0,6	0,6	25	0,092	HCB71908-E-T-P4S
	62	12	6,8	4,3	445	32 000	48 000	0,6	0,6	15	0,125	HS71908-C-T-P4S
	62	12	18	9,4	720	32 000	50 000	0,6	0,6	15	0,092	HCB71908-C-T-P4S
	62	12	6,4	3,9	295	36 000	56 000	0,6	0,6	25	0,119	HC71908-E-T-P4S
	62	12	9,7	3,9	295	40 000	63 000	0,6	0,6	25	0,119	XC71908-E-T-P4S
	68	15	19,9	10,6	1 100	20 000	30 000	1	1	25	0,189	B7008-E-T-P4S
	68	15	20,9	11,2	1 150	22 000	34 000	1	1	15	0,189	B7008-C-T-P4S
	68	15	8,9	5,4	560	26 000	40 000	1	1	25	0,211	HS7008-E-T-P4S
	68	15	19,9	10,2	780	28 000	43 000	1	1	25	0,166	HCB7008-E-T-P4S
	68	15	9,4	5,7	590	30 000	45 000	1	1	15	0,211	HS7008-C-T-P4S
	68	15	20,9	10,7	820	30 000	45 000	1	1	15	0,166	HCB7008-C-T-P4S
	68	15	8,9	5,2	395	34 000	53 000	1	1	25	0,204	HC7008-E-T-P4S
	68	15	13,7	5,2	395	38 000	60 000	1	1	25	0,204	XC7008-E-T-P4S
	80	18	31	15,4	1 580	17 000	28 000	1,1	1,1	25	0,371	B7208-E-T-P4S
	80	18	32,5	16,1	1 660	18 000	30 000	1,1	1,1	15	0,372	B7208-C-T-P4S
	80	18	31	14,7	1 120	20 000	34 000	1,1	1,1	25	0,321	HCB7208-E-T-P4S
	80	18	32,5	15,4	1 170	24 000	38 000	1,1	1,1	15	0,322	HCB7208-C-T-P4S

medias ► <https://www.schaeffler.de/std/1DBE>

- 1) The limiting speeds are based on elastically preloaded single bearings.
- 2) Explanation of designations ► SP 1.
- 3) The bearings are also available with gap seals (type HSS, HCS, XCS or suffix 2RSD).
Ordering examples: B7000-C-2RSD-T-P4S-UL and HSS7000-E-T-P4S-UL.
- 4) L = light preload; M = moderate preload; H = high preload.
- 5) Minimal quantity oil lubrication.

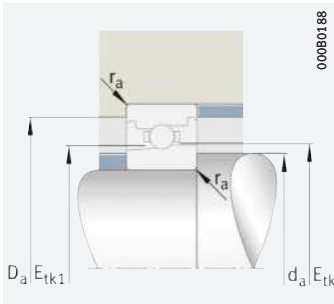

Mounting dimensions

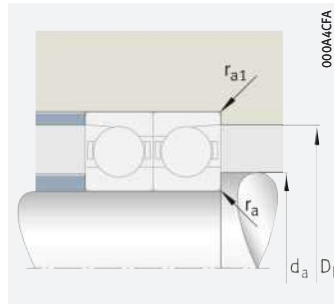

Mounting dimensions

d	Mounting dimensions							Preload force ⁴⁾ F _V			Lift-off force ⁴⁾ K _{aE}			Axial rigidity ⁴⁾ c _a		
	d _a h12	D _a H12	r _a	r _{a1}	E _{tk}	E _{tk1}	E _{tk} E _{tk1}	L	M	H	L	M	H	L	M	H
			max.	max.	min.	min.	max.	N	N	N	N	N	N	N/μm	N/μm	N/μm
40	45	58,5	0,6	0,15	47,3	47,3	49,1	111	447	974	324	1 348	3 043	91,3	155	213
	45	58,5	0,6	0,15	47,3	47,3	49,1	84	292	594	259	979	2 140	40,7	71,6	103
	45	58,5	0,6	0,15	48,6	47,2	49,3	39	117	235	113	345	704	66,6	99,2	129
	45	58,5	0,6	0,15	47,3	47,3	49,1	41	220	514	117	645	1 548	72,4	132	183
	45	58,5	0,6	0,15	48,6	47,2	49,3	24	72	145	72	227	473	26,6	41,8	57,2
	45	58,5	0,6	0,15	47,3	47,3	49,1	39	156	337	116	494	1 127	33,5	59,2	84,7
	45	58,5	0,6	0,15	48,6	47,2	49,3	27	82	164	78	238	484	66,4	98	127
	45	58,5	0,6	0,15	48,6	47,2	49,3	27	82	164	78	238	484	66,4	98	127
	46	62	1	0,3	49,3	49,3	51,8	141	543	1 170	410	1 640	3 663	98,6	165	227
	46	62	1	0,3	49,3	49,3	51,8	101	344	698	312	1 157	2 515	43,2	75,6	109
	46	62	1	0,3	51,2	49,4	52,3	53	160	321	154	472	964	74,7	111	145
	46	62	1	0,3	49,3	49,3	51,8	55	271	622	159	797	1 875	80	142	195
	46	62	1	0,3	51,2	49,4	52,3	34	101	201	100	316	659	30,1	47,4	64,9
	46	62	1	0,3	49,3	49,3	51,8	49	188	402	146	597	1 350	36,1	63,1	89,9
	46	62	1	0,3	51,2	49,4	52,3	37	110	221	106	321	652	74,2	110	142
	46	62	1	0,3	51,2	49,4	52,3	37	110	221	106	321	652	74,2	110	142
	48	72	1	0,6	53,4	53,4	57,2	257	906	1 903	750	2 748	5 985	114	184	252
	48	72	1	0,6	53,4	53,4	57,2	175	566	1 128	544	1 920	4 102	49,2	84,7	122
	48	72	1	0,6	53,4	53,4	57,2	121	485	1 059	347	1 432	3 208	97,6	162	220
	48	72	1	0,6	53,4	53,4	57,2	89	312	650	266	996	2 193	41,6	70,6	99,8





Super precision angular contact ball bearings

With large or small balls
Steel or ceramic balls
Steel or Cronidur rings
Open or sealed

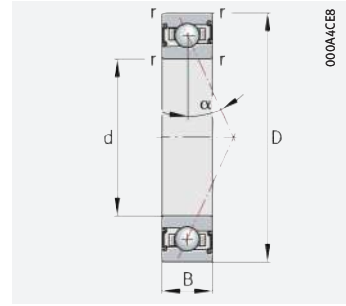
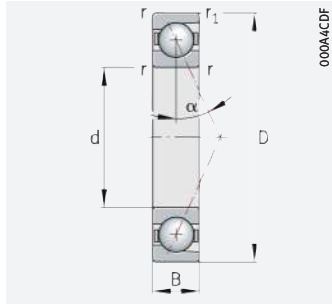

d = 45 – 45 mm

Main dimensions	Basic load ratings		Fatigue limit load		Limiting speeds ¹⁾		Dimensions		Contact angle	Mass	Designation ²⁾³⁾	
					C_r	stat. C_{0r}	C_{ur}	n_G grease				n_G oil ⁵⁾
d	D	B	dyn. C_r kN	stat. C_{0r} kN	C_{ur} N	min ⁻¹	min ⁻¹	min.	min.	°	≈ kg	
45	68	12	18,2	10,6	1 090	19 000	28 000	0,6	0,6	25	0,127	B71909-E-T-P4S
	68	12	19,1	11,2	1 150	20 000	32 000	0,6	0,6	15	0,127	B71909-C-T-P4S
	68	12	9,1	5,6	580	26 000	40 000	0,6	0,6	25	0,136	HS71909-E-T-P4S
	68	12	18,2	10,2	770	26 000	40 000	0,6	0,6	25	0,108	HCB71909-E-T-P4S
	68	12	9,6	6	610	28 000	43 000	0,6	0,6	15	0,136	HS71909-C-T-P4S
	68	12	19,1	10,7	820	28 000	45 000	0,6	0,6	15	0,108	HCB71909-C-T-P4S
	68	12	9,1	5,4	410	32 000	50 000	0,6	0,6	25	0,129	HC71909-E-T-P4S
	68	12	13,9	5,4	410	36 000	56 000	0,6	0,6	25	0,129	XC71909-E-T-P4S
	75	16	26,5	14,2	1 460	17 000	26 000	1	1	25	0,232	B7009-E-T-P4S
	75	16	28	14,9	1 530	19 000	30 000	1	1	15	0,232	B7009-C-T-P4S
	75	16	11,6	7,1	730	24 000	36 000	1	1	25	0,261	HS7009-E-T-P4S
	75	16	26,5	13,6	1 030	24 000	38 000	1	1	25	0,191	HCB7009-E-T-P4S
	75	16	12,3	7,5	770	26 000	40 000	1	1	15	0,262	HS7009-C-T-P4S
	75	16	28	14,3	1 090	26 000	40 000	1	1	15	0,191	HCB7009-C-T-P4S
	75	16	11,6	6,8	520	30 000	48 000	1	1	25	0,248	HC7009-E-T-P4S
	75	16	17,8	6,8	520	34 000	53 000	1	1	25	0,248	XC7009-E-T-P4S
	85	19	32,5	16,9	1 740	15 000	24 000	1,1	1,1	25	0,422	B7209-E-T-P4S
	85	19	34	17,7	1 820	17 000	28 000	1,1	1,1	15	0,423	B7209-C-T-P4S
	85	19	32,5	16,2	1 230	18 000	30 000	1,1	1,1	25	0,369	HCB7209-E-T-P4S
	85	19	34	17	1 290	22 000	36 000	1,1	1,1	15	0,37	HCB7209-C-T-P4S

medias ► <https://www.schaeffler.de/std/1DBF>

- 1) The limiting speeds are based on elastically preloaded single bearings.
- 2) Explanation of designations ► [SP 1](#).
- 3) The bearings are also available with gap seals (type HSS, HCS, XCS or suffix 2RSD).
Ordering examples: B7000-C-2RSD-T-P4S-UL and HSS7000-E-T-P4S-UL.
- 4) L = light preload; M = moderate preload; H = high preload.
- 5) Minimal quantity oil lubrication.

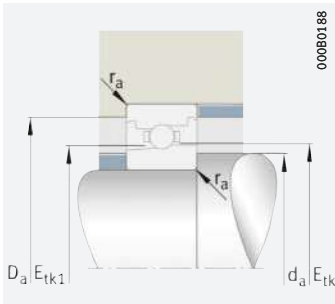

Mounting dimensions

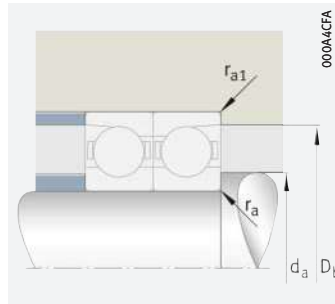

Mounting dimensions

d	Mounting dimensions							Preload force ⁴⁾ F _V			Lift-off force ⁴⁾ K _{aE}			Axial rigidity ⁴⁾ c _a		
	d _a h12	D _a H12	r _a max.	r _{a1} max.	E _{tk} min.	E _{tk1} min.	E _{tk} E _{tk1} max.	L	M	H	L	M	H	L	M	H
								N	N	N	N	N	N	N/μm	N/μm	N/μm
45	50	63,5	0,6	0,15	52,3	52,3	54,5	116	470	1 028	336	1 415	3 203	99	168	232
	50	63,5	0,6	0,15	52,3	52,3	54,5	88	307	628	270	1 027	2 251	44	77,5	112
	50	63,5	0,6	0,15	53,7	51,9	54,7	55	164	328	158	482	984	77,2	115	150
	50	63,5	0,6	0,15	52,3	52,3	54,5	42	233	547	121	682	1 643	78,5	144	200
	50	63,5	0,6	0,15	53,7	51,9	54,7	34	101	201	100	316	657	30,8	48,4	66,2
	50	63,5	0,6	0,15	52,3	52,3	54,5	40	164	355	120	516	1 182	36,2	64,1	91,7
	50	63,5	0,6	0,15	53,7	51,9	54,7	38	113	226	108	329	667	76,6	113	146
	50	63,5	0,6	0,15	53,7	51,9	54,7	38	113	226	108	329	667	76,6	113	146
	51	69	1	0,3	54,3	54,3	57,3	208	763	1 622	606	2 308	5 082	115	189	259
	51	69	1	0,3	54,3	54,3	57,3	144	476	958	445	1 606	3 461	49,8	86,3	124
	51	69	1	0,3	56,7	54,6	58,2	70	210	421	203	621	1 269	85,4	128	167
	51	69	1	0,3	54,3	54,3	57,3	89	389	869	254	1 145	2 622	95,8	163	223
	51	69	1	0,3	56,7	54,6	58,2	43	130	259	130	409	853	34,3	54,1	74,3
	51	69	1	0,3	54,3	54,3	57,3	71	261	549	212	827	1 843	41,9	71,9	102
	51	69	1	0,3	56,7	54,6	58,2	48	143	286	137	417	848	84,4	125	161
	51	69	1	0,3	56,7	54,6	58,2	48	143	286	137	417	848	84,4	125	161
	52,5	78	1	0,6	58,5	58,5	62,2	268	948	1 994	782	2 873	6 261	121	196	268
	52,5	78	1	0,6	58,5	58,5	62,2	182	592	1 182	567	2 003	4 286	52,2	90	129
	52,5	78	1	0,6	58,5	58,5	62,2	123	500	1 095	354	1 475	3 312	103	172	233
	52,5	78	1	0,6	58,5	58,5	62,2	93	329	685	279	1 047	2 307	44,4	75,3	106





Super precision angular contact ball bearings

With large or small balls
Steel or ceramic balls
Steel or Cronidur rings
Open or sealed

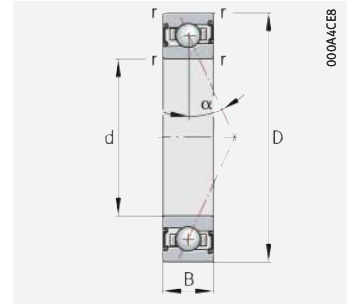
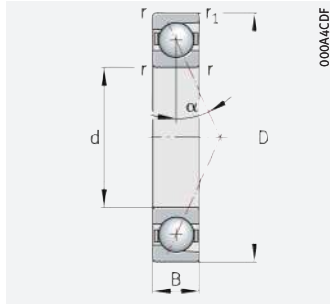

d = 50 – 50 mm

Main dimensions			Basic load ratings		Fatigue limit load C_{ur} N	Limiting speeds ¹⁾		Dimensions		Contact angle α °	Mass m ≈ kg	Designation ²⁾³⁾
d	D	B	dyn. C_r kN	stat. C_{0r} kN		n_G grease min ⁻¹	n_G oil ⁵⁾ min ⁻¹	r	r_1			
50	72	12	18,6	11,3	1 160	17 000	26 000	0,6	0,6	25	0,128	B71910-E-T-P4S
	72	12	19,6	11,9	1 230	19 000	30 000	0,6	0,6	15	0,128	B71910-C-T-P4S
	72	12	9,4	6,1	630	24 000	36 000	0,6	0,6	25	0,138	HS71910-E-T-P4S
	72	12	18,6	10,8	820	24 000	36 000	0,6	0,6	25	0,109	HCB71910-E-T-P4S
	72	12	9,9	6,5	670	26 000	40 000	0,6	0,6	15	0,138	HS71910-C-T-P4S
	72	12	19,6	11,4	870	26 000	40 000	0,6	0,6	15	0,109	HCB71910-C-T-P4S
	72	12	9,4	5,8	445	30 000	48 000	0,6	0,6	25	0,131	HC71910-E-T-P4S
	72	12	14,3	5,8	445	34 000	53 000	0,6	0,6	25	0,131	XC71910-E-T-P4S
	80	16	27,5	15,3	1 580	16 000	24 000	1	1	25	0,25	B7010-E-T-P4S
	80	16	29	16,1	1 660	18 000	28 000	1	1	15	0,25	B7010-C-T-P4S
	80	16	12,1	7,7	790	22 000	34 000	1	1	25	0,282	HS7010-E-T-P4S
	80	16	27,5	14,7	1 120	22 000	34 000	1	1	25	0,213	HCB7010-E-T-P4S
	80	16	12,8	8,2	840	24 000	38 000	1	1	15	0,283	HS7010-C-T-P4S
	80	16	29	15,4	1 170	24 000	38 000	1	1	15	0,213	HCB7010-C-T-P4S
	80	16	12,1	7,4	560	28 000	43 000	1	1	25	0,269	HC7010-E-T-P4S
	80	16	18,4	7,4	560	32 000	48 000	1	1	25	0,269	XC7010-E-T-P4S
	90	20	41	21,4	2 200	14 000	22 000	1,1	1,1	25	0,446	B7210-E-T-P4S
	90	20	43	22,4	2 300	16 000	26 000	1,1	1,1	15	0,448	B7210-C-T-P4S
90	20	41	20,4	1 560	17 000	28 000	1,1	1,1	25	0,382	HCB7210-E-T-P4S	
90	20	43	21,4	1 630	20 000	34 000	1,1	1,1	15	0,384	HCB7210-C-T-P4S	

medias ► <https://www.schaeffler.de/std/1DC0>

- 1) The limiting speeds are based on elastically preloaded single bearings.
- 2) Explanation of designations ► [SP 1](#).
- 3) The bearings are also available with gap seals (type HSS, HCS, XCS or suffix 2RSD).
Ordering examples: B7000-C-2RSD-T-P4S-UL and HSS7000-E-T-P4S-UL.
- 4) L = light preload; M = moderate preload; H = high preload.
- 5) Minimal quantity oil lubrication.

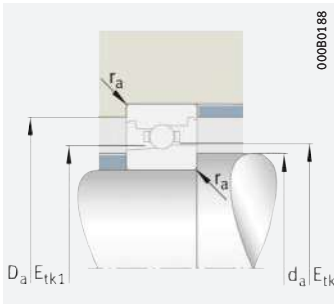

Mounting dimensions

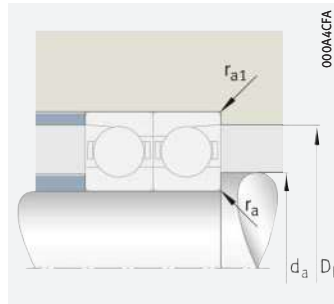

Mounting dimensions

d	Mounting dimensions							Preload force ⁴⁾ F _V			Lift-off force ⁴⁾ K _{aE}			Axial rigidity ⁴⁾ c _a		
	d _a h12	D _a H12	r _a	r _{a1}	E _{tk}	E _{tk1}	E _{tk} E _{tk1} max.	L	M	H	L	M	H	L	M	H
			max.	max.	min.	min.	max.	N	N	N	N	N	N	N/μm	N/μm	N/μm
50	55	67,5	0,6	0,15	56,8	56,8	58,9	117	479	1 049	340	1 439	3 263	103	174	241
	55	67,5	0,6	0,15	56,8	56,8	58,9	89	313	642	274	1 044	2 293	45,6	80,2	116
	55	67,5	0,6	0,15	58,2	56,4	59,1	56	169	338	163	497	1 014	81,7	122	159
	55	67,5	0,6	0,15	56,8	56,8	58,9	40	229	542	115	671	1 626	79,7	148	205
	55	67,5	0,6	0,15	58,2	56,4	59,1	35	105	209	104	328	682	32,6	51,2	70
	55	67,5	0,6	0,15	56,8	56,8	58,9	41	167	362	121	525	1 205	37,5	66,4	95
	55	67,5	0,6	0,15	58,2	56,4	59,1	39	116	231	110	336	682	80,9	119	154
	55	67,5	0,6	0,15	58,2	56,4	59,1	39	116	231	110	336	682	80,9	119	154
	56	74	1	0,3	59,3	59,3	62,3	209	774	1 648	610	2 336	5 151	120	197	270
	56	74	1	0,3	59,3	59,3	62,3	148	493	994	459	1 659	3 579	52,3	90,5	130
	56	74	1	0,3	61,7	59,6	63	72	216	431	208	635	1 297	90,6	135	176
	56	74	1	0,3	59,3	59,3	62,3	90	400	895	259	1 175	2 697	100	171	234
	56	74	1	0,3	61,7	59,6	63	45	135	269	135	424	884	36,4	57,4	78,8
	56	74	1	0,3	59,3	59,3	62,3	73	268	566	217	848	1 894	43,9	75,3	107
	56	74	1	0,3	61,7	59,6	63	50	149	298	143	435	883	90	133	172
	56	74	1	0,3	61,7	59,6	63	50	149	298	143	435	883	90	133	172
	57	83	1	0,6	62,4	62,4	66,8	352	1 221	2 553	1 027	3 697	8 006	138	223	303
	57	83	1	0,6	62,4	62,4	66,8	240	771	1 534	746	2 606	5 556	59,9	103	147
	57	83	1	0,6	62,4	62,4	66,8	168	656	1 420	484	1 933	4 292	120	197	265
	57	83	1	0,6	62,4	62,4	66,8	126	434	898	377	1 383	3 027	51,4	86,5	122





Super precision angular contact ball bearings

With large or small balls
Steel or ceramic balls
Steel or Cronidur rings
Open or sealed

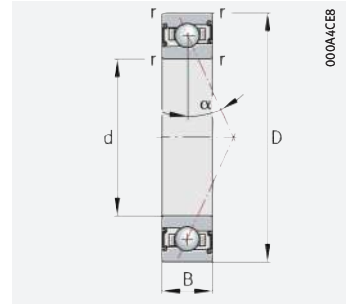
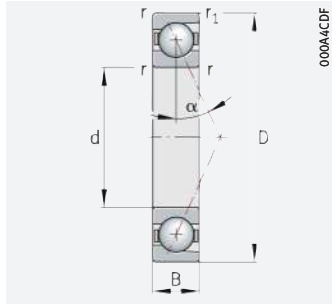

d = 55 – 55 mm

Main dimensions			Basic load ratings		Fatigue limit load C_{ur} N	Limiting speeds ¹⁾		Dimensions		Contact angle α °	Mass m ≈ kg	Designation ²⁾³⁾
d	D	B	dyn. C_r kN	stat. C_{0r} kN		n_G grease min ⁻¹	n_G oil ⁵⁾ min ⁻¹	r	r_1			
							min.	min.				
55	80	13	22,2	13,7	1 410	15 000	24 000	1	1	25	0,174	B71911-E-T-P4S
	80	13	23,5	14,4	1 490	17 000	26 000	1	1	15	0,174	B71911-C-T-P4S
	80	13	12,3	8	830	22 000	32 000	1	1	25	0,186	HS71911-E-T-P4S
	80	13	22,2	13,1	1 000	22 000	32 000	1	1	25	0,148	HCB71911-E-T-P4S
	80	13	13	8,5	870	24 000	36 000	1	1	15	0,186	HS71911-C-T-P4S
	80	13	23,5	13,8	1 050	24 000	36 000	1	1	15	0,148	HCB71911-C-T-P4S
	80	13	12,3	7,7	590	28 000	43 000	1	1	25	0,172	HC71911-E-T-P4S
	80	13	18,8	7,7	590	30 000	48 000	1	1	25	0,172	XC71911-E-T-P4S
	90	18	37	21	2 160	14 000	22 000	1,1	1,1	25	0,371	B7011-E-T-P4S
	90	18	38,5	22,1	2 270	16 000	24 000	1,1	1,1	15	0,371	B7011-C-T-P4S
	90	18	16,9	10,9	1 120	20 000	30 000	1,1	1,1	25	0,404	HS7011-E-T-P4S
	90	18	37	20,1	1 530	20 000	30 000	1,1	1,1	25	0,311	HCB7011-E-T-P4S
	90	18	17,9	11,5	1 180	22 000	34 000	1,1	1,1	15	0,405	HS7011-C-T-P4S
	90	18	38,5	21,2	1 610	22 000	34 000	1,1	1,1	15	0,31	HCB7011-C-T-P4S
	90	18	16,9	10,4	790	26 000	40 000	1,1	1,1	25	0,386	HC7011-E-T-P4S
	90	18	26	10,4	790	28 000	43 000	1,1	1,1	25	0,386	XC7011-E-T-P4S
100	21	45	25	2 600	13 000	20 000	1,5	1,5	25	0,617	B7211-E-T-P4S	
100	21	47	26,5	2 700	14 000	22 000	1,5	1,5	15	0,619	B7211-C-T-P4S	
100	21	45	24	1 820	15 000	24 000	1,5	1,5	25	0,544	HCB7211-E-T-P4S	
100	21	47	25	1 910	18 000	30 000	1,5	1,5	15	0,546	HCB7211-C-T-P4S	

medias ► <https://www.schaeffler.de/std/1DC1>

- 1) The limiting speeds are based on elastically preloaded single bearings.
- 2) Explanation of designations ► [SP 1](#).
- 3) The bearings are also available with gap seals (type HSS, HCS, XCS or suffix 2RSD).
Ordering examples: B7000-C-2RSD-T-P4S-UL and HSS7000-E-T-P4S-UL.
- 4) L = light preload; M = moderate preload; H = high preload.
- 5) Minimal quantity oil lubrication.

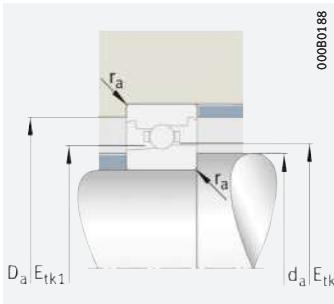

Mounting dimensions

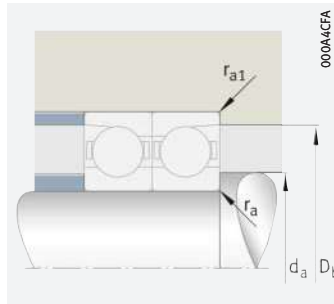

Mounting dimensions

d	Mounting dimensions							Preload force ⁴⁾ F _V			Lift-off force ⁴⁾ K _{aE}			Axial rigidity ⁴⁾ c _a		
	d _a h12	D _a H12	r _a	r _{a1}	E _{tk}	E _{tk1}	E _{tk} E _{tk1}	L	M	H	L	M	H	L	M	H
			max.	max.	min.	min.	max.	N	N	N	N	N	N	N/μm	N/μm	N/μm
55	60	75,5	0,6	0,3	62,8	62,8	65,1	149	588	1 278	431	1 768	3 973	115	193	266
	60	75,5	0,6	0,3	62,8	62,8	65,1	111	382	780	340	1 274	2 784	50,8	88,6	128
	60	75,5	0,6	0,3	64,2	62,1	65,4	73	219	438	211	645	1 317	93,2	139	181
	60	75,5	0,6	0,3	62,8	62,8	65,1	57	296	686	164	867	2 058	93	167	230
	60	75,5	0,6	0,3	64,2	62,1	65,4	45	135	269	135	424	882	37,3	58,6	80,3
	60	75,5	0,6	0,3	62,8	62,8	65,1	53	208	447	157	654	1 487	42,4	74,1	106
	60	75,5	0,6	0,3	64,2	62,1	65,4	51	152	304	145	442	897	92,7	137	177
	60	75,5	0,6	0,3	64,2	62,1	65,4	51	152	304	145	442	897	92,7	137	177
	62	83	1	0,6	65,9	65,9	69,6	296	1 059	2 234	862	3 197	6 983	142	230	314
	62	83	1	0,6	65,9	65,9	69,6	205	670	1 344	635	2 253	4 837	61,4	106	151
	62	83	1	0,6	68,5	65,9	70,3	101	304	607	292	895	1 826	106	157	206
	62	83	1	0,6	65,9	65,9	69,6	136	562	1 236	390	1 653	3 728	121	203	275
	62	83	1	0,6	68,5	65,9	70,3	62	187	374	187	588	1 225	42,2	66,5	91,1
	62	83	1	0,6	65,9	65,9	69,6	102	366	765	305	1 158	2 559	51,9	87,9	124
	62	83	1	0,6	68,5	65,9	70,3	70	210	421	201	613	1 244	105	155	201
	62	83	1	0,6	68,5	65,9	70,3	70	210	421	201	613	1 244	105	155	201
	63	92	1,5	0,6	69,9	69,9	74,3	378	1 321	2 767	1 103	3 991	8 652	155	249	339
	63	92	1,5	0,6	69,9	69,9	74,3	258	832	1 662	800	2 800	5 985	66,7	114	163
	63	92	1,5	0,6	69,9	69,9	74,3	180	709	1 540	518	2 088	4 646	134	220	297
	63	92	1,5	0,6	69,9	69,9	74,3	132	460	956	395	1 460	3 203	56,9	95,6	135





Super precision angular contact ball bearings

- With large or small balls
- Steel or ceramic balls
- Steel or Cronidur rings
- Open or sealed

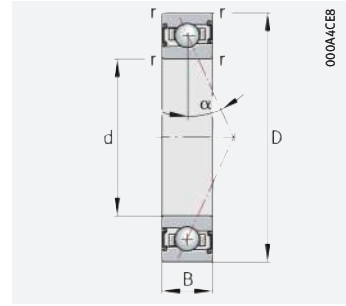
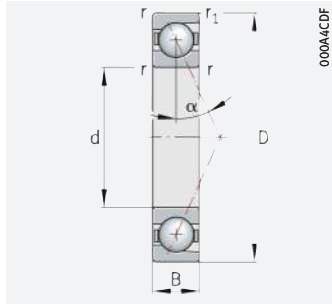

d = 60 – 60 mm

Main dimensions			Basic load ratings		Fatigue limit load C_{ur}	Limiting speeds ¹⁾		Dimensions		Contact angle α	Mass m ≈ kg	Designation ²⁾³⁾
d	D	B	dyn. C_r kN	stat. C_{0r} kN		n_G grease min ⁻¹	n_G oil ⁵⁾ min ⁻¹	r	r_1			
											°	
60	85	13	23,4	15,2	1 560	14 000	22 000	1	1	25	0,188	B71912-E-T-P4S
	85	13	24,7	16	1 650	16 000	24 000	1	1	15	0,188	B71912-C-T-P4S
	85	13	12,6	8,7	890	20 000	30 000	1	1	25	0,2	HS71912-E-T-P4S
	85	13	23,4	14,5	1 100	20 000	30 000	1	1	25	0,159	HCB71912-E-T-P4S
	85	13	13,4	9,2	940	22 000	34 000	1	1	15	0,2	HS71912-C-T-P4S
	85	13	24,7	15,3	1 170	22 000	34 000	1	1	15	0,159	HCB71912-C-T-P4S
	85	13	12,6	8,3	630	26 000	40 000	1	1	25	0,185	HC71912-E-T-P4S
	85	13	19,4	8,3	630	28 000	43 000	1	1	25	0,184	XC71912-E-T-P4S
	95	18	38	22,6	2 320	13 000	20 000	1,1	1,1	25	0,396	B7012-E-T-P4S
	95	18	40	23,8	2 440	15 000	22 000	1,1	1,1	15	0,395	B7012-C-T-P4S
	95	18	17,6	11,8	1 210	18 000	28 000	1,1	1,1	25	0,433	HS7012-E-T-P4S
	95	18	38	21,6	1 650	19 000	28 000	1,1	1,1	25	0,335	HCB7012-E-T-P4S
	95	18	18,6	12,5	1 280	20 000	32 000	1,1	1,1	15	0,433	HS7012-C-T-P4S
	95	18	40	22,7	1 730	20 000	32 000	1,1	1,1	15	0,335	HCB7012-C-T-P4S
	95	18	17,6	11,3	860	24 000	36 000	1,1	1,1	25	0,413	HC7012-E-T-P4S
	95	18	27	11,3	860	26 000	40 000	1,1	1,1	25	0,413	XC7012-E-T-P4S
110	22	53	29,5	3 050	12 000	19 000	1,5	1,5	25	0,793	B7212-E-T-P4S	
110	22	56	31	3 200	13 000	20 000	1,5	1,5	15	0,795	B7212-C-T-P4S	
110	22	53	28,5	2 150	14 000	22 000	1,5	1,5	25	0,685	HCB7212-E-T-P4S	
110	22	56	29,5	2 260	16 000	26 000	1,5	1,5	15	0,687	HCB7212-C-T-P4S	

medias ► <https://www.schaeffler.de/std/1DC2>

- The limiting speeds are based on elastically preloaded single bearings.
- Explanation of designations ► [SP 1](#).
- The bearings are also available with gap seals (type HSS, HCS, XCS or suffix 2RSD).
Ordering examples: B7000-C-2RSD-T-P4S-UL and HSS7000-E-T-P4S-UL.
- L = light preload; M = moderate preload; H = high preload.
- Minimal quantity oil lubrication.

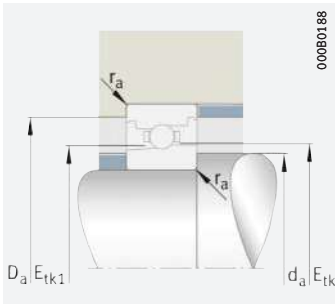

Mounting dimensions

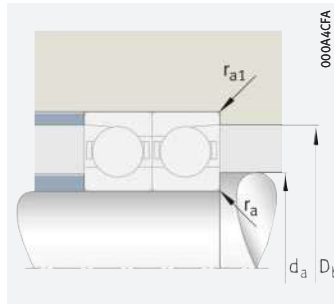

Mounting dimensions

d	Mounting dimensions							Preload force ⁴⁾ F _V			Lift-off force ⁴⁾ K _{aE}			Axial rigidity ⁴⁾ c _a		
	d _a h12	D _a H12	r _a	r _{a1}	E _{tk}	E _{tk1}	E _{tk} E _{tk1}	L	M	H	L	M	H	L	M	H
			max.	max.	min.	min.	max.	N	N	N	N	N	N	N/μm	N/μm	N/μm
60	65	80,5	0,6	0,3	67,8	67,8	70,1	155	617	1 344	448	1 853	4 171	124	208	286
	65	80,5	0,6	0,3	67,8	67,8	70,1	116	401	822	354	1 333	2 919	54,5	95,1	137
	65	80,5	0,6	0,3	69,2	67,1	70,4	76	228	455	219	670	1 368	98,8	147	192
	65	80,5	0,6	0,3	67,8	67,8	70,1	57	303	707	163	887	2 118	98,5	179	246
	65	80,5	0,6	0,3	69,2	67,1	70,4	47	141	281	140	442	920	39,5	62,1	85
	65	80,5	0,6	0,3	67,8	67,8	70,1	54	214	462	159	671	1 530	45,1	79	112
	65	80,5	0,6	0,3	69,2	67,1	70,4	52	155	311	148	452	917	97,7	144	186
	65	80,5	0,6	0,3	69,2	67,1	70,4	52	155	311	148	452	917	97,7	144	186
	67	88	1	0,6	70,9	70,9	74,5	297	1 069	2 259	864	3 221	7 045	147	239	326
	67	88	1	0,6	70,9	70,9	74,5	209	687	1 381	647	2 304	4 952	64	110	157
	67	88	1	0,6	73,5	70,9	75,3	105	316	631	304	929	1 896	112	167	218
	67	88	1	0,6	70,9	70,9	74,5	136	569	1 256	391	1 673	3 782	126	211	286
	67	88	1	0,6	73,5	70,9	75,3	65	194	388	194	609	1 269	44,8	70,5	96,4
	67	88	1	0,6	70,9	70,9	74,5	106	379	794	315	1 198	2 651	54,4	92,2	130
	67	88	1	0,6	73,5	70,9	75,3	73	219	438	209	638	1 294	112	165	213
	67	88	1	0,6	73,5	70,9	75,3	73	219	438	209	638	1 294	112	165	213
	69,5	101,5	1,5	0,6	77	77	81,9	463	1 586	3 304	1 351	4 794	10 334	165	264	358
	69,5	101,5	1,5	0,6	77	77	81,9	312	996	1 982	968	3 352	7 140	70,9	121	172
	69,5	101,5	1,5	0,6	77	77	81,9	226	859	1 847	651	2 531	5 576	144	234	315
	69,5	101,5	1,5	0,6	77	77	81,9	163	557	1 149	488	1 767	3 852	60,9	102	143





Super precision angular contact ball bearings

- With large or small balls
- Steel or ceramic balls
- Steel or Cronidur rings
- Open or sealed

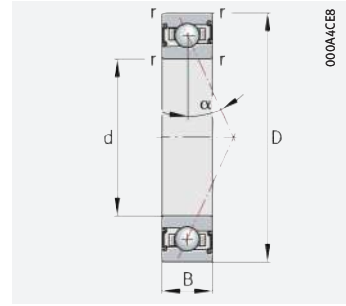
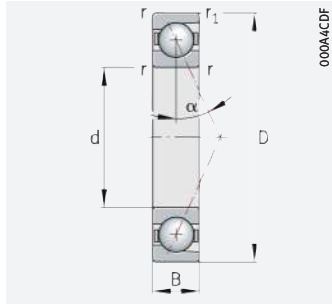

d = 65 – 65 mm

Main dimensions			Basic load ratings		Fatigue limit load C_{ur} N	Limiting speeds ¹⁾		Dimensions		Contact angle α °	Mass m ≈ kg	Designation ²⁾³⁾
d	D	B	dyn. C_r kN	stat. C_{0r} kN		n_G grease min ⁻¹	n_G oil ⁵⁾ min ⁻¹	r	r ₁			
							min.	min.				
65	90	13	23,7	16	1 640	13 000	20 000	1	1	25	0,2	B71913-E-T-P4S
	90	13	25	16,9	1 740	15 000	22 000	1	1	15	0,2	B71913-C-T-P4S
	90	13	13	9,3	960	18 000	28 000	1	1	25	0,214	HS71913-E-T-P4S
	90	13	23,7	15,3	1 160	19 000	28 000	1	1	25	0,17	HCB71913-E-T-P4S
	90	13	13,8	9,9	1 010	20 000	32 000	1	1	15	0,214	HS71913-C-T-P4S
	90	13	25	16,1	1 230	20 000	32 000	1	1	15	0,17	HCB71913-C-T-P4S
	90	13	13	8,9	680	24 000	36 000	1	1	25	0,198	HC71913-E-T-P4S
	90	13	19,9	8,9	680	26 000	40 000	1	1	25	0,197	XC71913-E-T-P4S
	100	18	39	24,1	2 480	13 000	19 000	1,1	1,1	25	0,42	B7013-E-T-P4S
	100	18	41,5	25,5	2 600	14 000	22 000	1,1	1,1	15	0,42	B7013-C-T-P4S
	100	18	18,2	12,7	1 310	17 000	26 000	1,1	1,1	25	0,461	HS7013-E-T-P4S
	100	18	39	23,1	1 760	17 000	26 000	1,1	1,1	25	0,356	HCB7013-E-T-P4S
	100	18	19,3	13,4	1 380	19 000	30 000	1,1	1,1	15	0,461	HS7013-C-T-P4S
	100	18	41,5	24,3	1 850	19 000	30 000	1,1	1,1	15	0,356	HCB7013-C-T-P4S
	100	18	18,2	12,2	930	22 000	34 000	1,1	1,1	25	0,44	HC7013-E-T-P4S
	100	18	28	12,2	930	24 000	38 000	1,1	1,1	25	0,44	XC7013-E-T-P4S
120	23	65	36,5	3 750	11 000	18 000	1,5	1,5	25	0,998	B7213-E-T-P4S	
120	23	68	38,5	3 950	12 000	19 000	1,5	1,5	15	1	B7213-C-T-P4S	
120	23	65	35	2 650	13 000	20 000	1,5	1,5	25	0,863	HCB7213-E-T-P4S	
120	23	68	36,5	2 800	15 000	24 000	1,5	1,5	15	0,866	HCB7213-C-T-P4S	

medias ► <https://www.schaeffler.de/std/1DC3>

- The limiting speeds are based on elastically preloaded single bearings.
- Explanation of designations ► [SP 1](#).
- The bearings are also available with gap seals (type HSS, HCS, XCS or suffix 2RSD).
Ordering examples: B7000-C-2RSD-T-P4S-UL and HSS7000-E-T-P4S-UL.
- L = light preload; M = moderate preload; H = high preload.
- Minimal quantity oil lubrication.

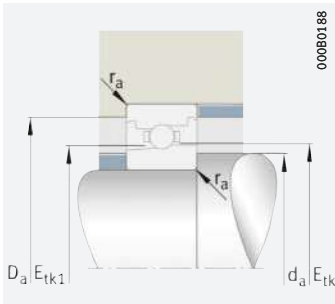

Mounting dimensions

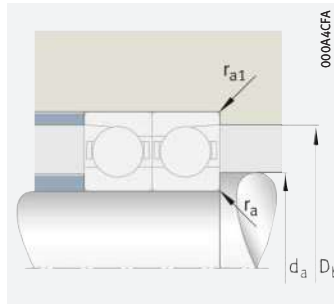

Mounting dimensions

d	Mounting dimensions							Preload force ⁴⁾ F _V			Lift-off force ⁴⁾ K _{aE}			Axial rigidity ⁴⁾ c _a		
	d _a h12	D _a H12	r _a	r _{a1}	E _{tk}	E _{tk1}	E _{tk} E _{tk1}	L	M	H	L	M	H	L	M	H
			max.	max.	min.	min.	max.	N	N	N	N	N	N	N/μm	N/μm	N/μm
65	70	85,5	0,6	0,3	72,8	72,8	75,1	152	613	1 339	440	1 837	4 145	126	213	293
	70	85,5	0,6	0,3	72,8	72,8	75,1	117	409	839	360	1 356	2 973	56,2	98,1	141
	70	85,5	0,6	0,3	74,2	72,1	75,3	77	231	462	222	680	1 386	104	154	201
	70	85,5	0,6	0,3	72,8	72,8	75,1	58	309	723	165	904	2 165	102	185	255
	70	85,5	0,6	0,3	74,2	72,1	75,3	48	144	287	143	450	937	41,5	65	88,8
	70	85,5	0,6	0,3	72,8	72,8	75,1	55	219	473	161	684	1 562	46,6	81,7	116
	70	85,5	0,6	0,3	74,2	72,1	75,3	53	160	321	153	466	946	103	152	196
	70	85,5	0,6	0,3	74,2	72,1	75,3	53	160	321	153	466	946	103	152	196
	72	93	1	0,6	75,9	75,9	79,5	308	1 111	2 350	896	3 347	7 323	154	251	342
	72	93	1	0,6	75,9	75,9	79,5	214	704	1 417	660	2 354	5 068	66,7	114	164
	72	93	1	0,6	78,5	75,9	80,2	109	328	656	315	964	1 967	119	177	231
	72	93	1	0,6	75,9	75,9	79,5	137	577	1 276	392	1 694	3 836	131	219	297
	72	93	1	0,6	78,5	75,9	80,2	67	201	402	200	630	1 312	47,4	74,4	102
	72	93	1	0,6	75,9	75,9	79,5	107	385	808	318	1 213	2 688	56,4	95,6	135
	72	93	1	0,6	78,5	75,9	80,2	74	223	445	213	647	1 313	118	173	224
	72	93	1	0,6	78,5	75,9	80,2	74	223	445	213	647	1 313	118	173	224
	75,5	109,5	1,5	0,6	83	83	88,6	585	1 977	4 100	1 709	5 978	12 828	185	295	399
	75,5	109,5	1,5	0,6	83	83	88,6	386	1 224	2 431	1 198	4 118	8 752	78,9	134	191
	75,5	109,5	1,5	0,6	83	83	88,6	290	1 071	2 286	834	3 157	6 901	162	261	350
	75,5	109,5	1,5	0,6	83	83	88,6	205	690	1 419	614	2 192	4 757	68,2	113	159





Super precision angular contact ball bearings

With large or small balls
Steel or ceramic balls
Steel or Cronidur rings
Open or sealed

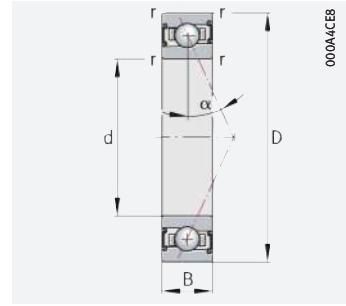
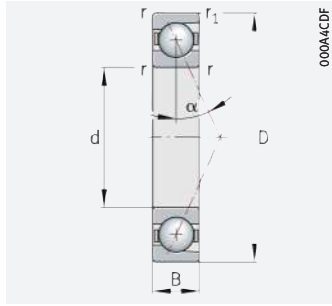

d = 70 – 70 mm

Main dimensions			Basic load ratings		Fatigue limit load C_{ur} N	Limiting speeds ¹⁾		Dimensions		Contact angle α °	Mass m ≈ kg	Designation ²⁾³⁾
d	D	B	dyn. C_r kN	stat. C_{0r} kN		n_G grease min ⁻¹	n_G oil ⁵⁾ min ⁻¹	r	r_1			
								min.	min.			
70	100	16	32,5	21,8	2 240	12 000	19 000	1	1	25	0,33	B71914-E-T-P4S
	100	16	34,5	23	2 360	14 000	20 000	1	1	15	0,33	B71914-C-T-P4S
	100	16	16,8	12,2	1 250	17 000	26 000	1	1	25	0,353	HS71914-E-T-P4S
	100	16	32,5	20,8	1 580	17 000	26 000	1	1	25	0,28	HCB71914-E-T-P4S
	100	16	17,8	12,9	1 330	19 000	28 000	1	1	15	0,354	HS71914-C-T-P4S
	100	16	34,5	22	1 670	19 000	28 000	1	1	15	0,28	HCB71914-C-T-P4S
	100	16	16,8	11,7	890	22 000	34 000	1	1	25	0,334	HC71914-E-T-P4S
	100	16	25,5	11,7	890	24 000	36 000	1	1	25	0,334	XC71914-E-T-P4S
	110	20	48	29	3 000	11 000	18 000	1,1	1,1	25	0,59	B7014-E-T-P4S
	110	20	50	30,5	3 150	13 000	20 000	1,1	1,1	15	0,59	B7014-C-T-P4S
	110	20	23,6	16,3	1 670	16 000	24 000	1,1	1,1	25	0,643	HS7014-E-T-P4S
	110	20	48	28	2 120	16 000	24 000	1,1	1,1	25	0,495	HCB7014-E-T-P4S
	110	20	25	17,2	1 770	18 000	28 000	1,1	1,1	15	0,644	HS7014-C-T-P4S
	110	20	50	29,5	2 230	18 000	28 000	1,1	1,1	15	0,495	HCB7014-C-T-P4S
	110	20	23,6	15,6	1 190	20 000	32 000	1,1	1,1	25	0,611	HC7014-E-T-P4S
	110	20	36	15,6	1 190	22 000	34 000	1,1	1,1	25	0,611	XC7014-E-T-P4S
125	24	67	39,5	4 050	10 000	17 000	1,5	1,5	25	1,09	B7214-E-T-P4S	
125	24	71	41,5	4 250	11 000	18 000	1,5	1,5	15	1,1	B7214-C-T-P4S	
125	24	67	38	2 900	12 000	19 000	1,5	1,5	25	0,951	HCB7214-E-T-P4S	
125	24	71	39,5	3 000	14 000	22 000	1,5	1,5	15	0,954	HCB7214-C-T-P4S	

medias ► <https://www.schaeffler.de/std/1DC4>

- 1) The limiting speeds are based on elastically preloaded single bearings.
- 2) Explanation of designations ► [SP 1](#).
- 3) The bearings are also available with gap seals (type HSS, HCS, XCS or suffix 2RSD).
Ordering examples: B7000-C-2RSD-T-P4S-UL and HSS7000-E-T-P4S-UL.
- 4) L = light preload; M = moderate preload; H = high preload.
- 5) Minimal quantity oil lubrication.

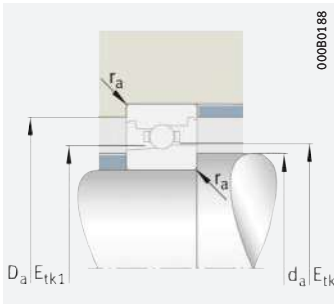

Mounting dimensions

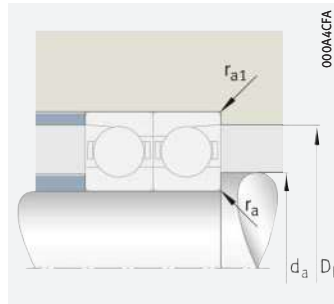

Mounting dimensions

d	Mounting dimensions							Preload force ⁴⁾ F _V			Lift-off force ⁴⁾ K _{aE}			Axial rigidity ⁴⁾ c _a		
	d _a h12	D _a H12	r _a	r _{a1}	E _{tk}	E _{tk1}	E _{tk} E _{tk1} max.	L	M	H	L	M	H	L	M	H
			max.	max.	min.	min.		N	N	N	N	N	N	N/μm	N/μm	N/μm
70	76	94,5	0,6	0,3	79,3	79,3	82,2	233	886	1902	677	2658	5898	151	249	341
	76	94,5	0,6	0,3	79,3	79,3	82,2	170	576	1171	523	1912	4155	66	114	163
	76	94,5	0,6	0,3	81,2	78,8	82,6	99	298	597	287	877	1789	118	176	229
	76	94,5	0,6	0,3	79,3	79,3	82,2	98	459	1040	281	1343	3118	126	218	298
	76	94,5	0,6	0,3	81,2	78,8	82,6	61	184	368	183	576	1198	47	73,7	101
	76	94,5	0,6	0,3	79,3	79,3	82,2	83	312	665	245	980	2200	55,5	95,3	135
	76	94,5	0,6	0,3	81,2	78,8	82,6	69	207	414	198	602	1221	117	173	223
	76	94,5	0,6	0,3	81,2	78,8	82,6	69	207	414	198	602	1221	117	173	223
	77	102	1	0,6	82,4	82,4	86,7	395	1388	2915	1149	4183	9083	169	273	371
	77	102	1	0,6	82,4	82,4	86,7	276	894	1790	853	2995	6414	73,5	125	179
	77	102	1	0,6	85,2	82,3	87,5	141	423	845	406	1243	2536	131	194	253
	77	102	1	0,6	82,4	82,4	86,7	188	749	1633	540	2203	4915	147	242	326
	77	102	1	0,6	85,2	82,3	87,5	87	261	523	261	820	1706	52,2	81,9	112
	77	102	1	0,6	82,4	82,4	86,7	139	487	1014	414	1538	3380	62,3	105	147
	77	102	1	0,6	85,2	82,3	87,5	98	293	587	280	853	1731	130	192	248
	77	102	1	0,6	85,2	82,3	87,5	98	293	587	280	853	1731	130	192	248
	80	115	1,5	0,6	88	88	93,6	595	2017	4189	1736	6090	13077	194	309	418
	80	115	1,5	0,6	88	88	93,6	399	1269	2524	1238	4260	9062	83,1	141	201
	80	115	1,5	0,6	88	88	93,6	297	1103	2359	854	3249	7111	171	275	368
	80	115	1,5	0,6	88	88	93,6	211	711	1464	630	2253	4894	71,6	119	166





Super precision angular contact ball bearings

With large or small balls
Steel or ceramic balls
Steel or Cronidur rings
Open or sealed

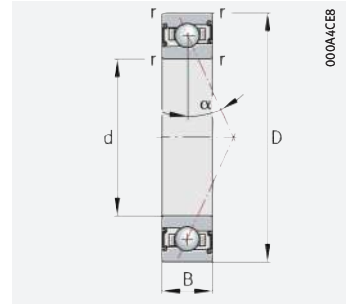
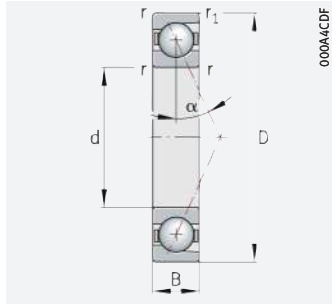

d = 75 – 75 mm

Main dimensions			Basic load ratings		Fatigue limit load C_{ur} N	Limiting speeds ¹⁾		Dimensions		Contact angle α °	Mass m ≈ kg	Designation ²⁾³⁾
d	D	B	dyn. C_r kN	stat. C_{0r} kN		n_G grease min^{-1}	n_G oil ⁵⁾ min^{-1}	r	r_1			
							min.	min.				
75	105	16	33	22,9	2 360	11 000	18 000	1	1	25	0,347	B71915-E-T-P4S
	105	16	35	24,2	2 490	13 000	20 000	1	1	15	0,347	B71915-C-T-P4S
	105	16	33	21,9	1 670	16 000	24 000	1	1	25	0,285	HCB71915-E-T-P4S
	105	16	17,2	13	1 340	16 000	24 000	1	1	25	0,373	HS71915-E-T-P4S
	105	16	35	23,1	1 760	18 000	28 000	1	1	15	0,285	HCB71915-C-T-P4S
	105	16	18,3	13,8	1 420	18 000	28 000	1	1	15	0,374	HS71915-C-T-P4S
	105	16	17,2	12,5	950	20 000	32 000	1	1	25	0,353	HC71915-E-T-P4S
	105	16	26,5	12,5	950	22 000	34 000	1	1	25	0,353	XC71915-E-T-P4S
	115	20	49,5	31	3 200	11 000	17 000	1,1	1,1	25	0,62	B7015-E-T-P4S
	115	20	52	32,5	3 350	12 000	19 000	1,1	1,1	15	0,62	B7015-C-T-P4S
	115	20	49,5	29,5	2 260	15 000	24 000	1,1	1,1	25	0,52	HCB7015-E-T-P4S
	115	20	23,9	17	1 740	15 000	24 000	1,1	1,1	25	0,678	HS7015-E-T-P4S
	115	20	25,5	17,9	1 850	17 000	26 000	1,1	1,1	15	0,679	HS7015-C-T-P4S
	115	20	52	31,5	2 380	17 000	26 000	1,1	1,1	15	0,52	HCB7015-C-T-P4S
	115	20	23,9	16,2	1 240	19 000	30 000	1,1	1,1	25	0,644	HC7015-E-T-P4S
	115	20	36,5	16,2	1 240	22 000	32 000	1,1	1,1	25	0,644	XC7015-E-T-P4S
	130	25	70	42,5	4 300	9 500	16 000	1,5	1,5	25	1,2	B7215-E-T-P4S
	130	25	73	44,5	4 550	11 000	18 000	1,5	1,5	15	1,2	B7215-C-T-P4S
130	25	70	40,5	3 050	12 000	19 000	1,5	1,5	25	1,04	HCB7215-E-T-P4S	
130	25	73	42,5	3 200	14 000	22 000	1,5	1,5	15	1,05	HCB7215-C-T-P4S	

medias ► <https://www.schaeffler.de/std/1DC5>

- 1) The limiting speeds are based on elastically preloaded single bearings.
- 2) Explanation of designations ► [SP 1](#).
- 3) The bearings are also available with gap seals (type HSS, HCS, XCS or suffix 2RSD).
Ordering examples: B7000-C-2RSD-T-P4S-UL and HSS7000-E-T-P4S-UL.
- 4) L = light preload; M = moderate preload; H = high preload.
- 5) Minimal quantity oil lubrication.

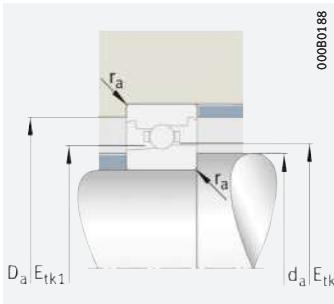

Mounting dimensions

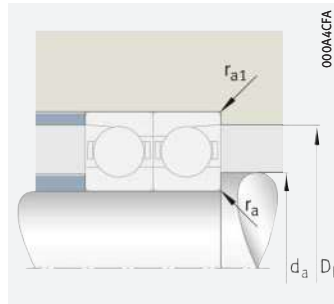

Mounting dimensions

d	Mounting dimensions							Preload force ⁴⁾ F _V			Lift-off force ⁴⁾ K _{aE}			Axial rigidity ⁴⁾ c _a		
	d _a h12	D _a H12	r _a	r _{a1}	E _{tk}	E _{tk1}	E _{tk} E _{tk1} max.	L	M	H	L	M	H	L	M	H
			max.	max.	min.	min.		N	N	N	N	N	N	N/μm	N/μm	N/μm
75	81	99,5	0,6	0,3	84,3	84,3	87,2	235	897	1928	682	2688	5970	156	257	351
	81	99,5	0,6	0,3	84,3	84,3	87,2	172	584	1189	527	1933	4206	68	117	168
	81	99,5	0,6	0,3	84,3	84,3	87,2	95	454	1034	273	1328	3094	128	223	305
	81	99,5	0,6	0,3	86,2	83,9	87,5	101	304	607	292	891	1817	123	183	239
	81	99,5	0,6	0,3	84,3	84,3	87,2	83	317	676	247	991	2229	57,1	98,2	139
	81	99,5	0,6	0,3	86,2	83,9	87,5	64	191	382	190	597	1242	49,5	77,5	106
	81	99,5	0,6	0,3	86,2	83,9	87,5	70	210	421	201	611	1240	123	181	233
	81	99,5	0,6	0,3	86,2	83,9	87,5	70	210	421	201	611	1240	123	181	233
	82	107	1	0,6	87,4	87,4	91,7	405	1430	3005	1180	4305	9353	177	285	387
	82	107	1	0,6	87,4	87,4	91,7	280	911	1827	865	3043	6525	76,3	130	186
	82	107	1	0,6	87,4	87,4	91,7	192	769	1679	551	2260	5050	153	253	341
	82	107	1	0,6	90,2	87,3	92,4	144	431	863	415	1268	2587	135	200	261
	82	107	1	0,6	90,2	87,3	92,4	89	266	533	265	835	1737	53,7	84,3	115
	82	107	1	0,6	87,4	87,4	91,7	145	508	1059	431	1603	3524	65,4	110	154
	82	107	1	0,6	90,2	87,3	92,4	99	298	597	285	868	1761	134	197	255
	82	107	1	0,6	90,2	87,3	92,4	99	298	597	285	868	1761	134	197	255
	85	120	1,5	0,6	93	93	98,5	615	2091	4345	1794	6306	13546	204	325	439
	85	120	1,5	0,6	93	93	98,5	413	1314	2617	1278	4401	9371	87,2	148	210
	85	120	1,5	0,6	93	93	98,5	308	1149	2459	887	3383	7409	180	290	388
	85	120	1,5	0,6	93	93	98,5	219	740	1524	653	2341	5087	75,4	125	175





Super precision angular contact ball bearings

With large or small balls
Steel or ceramic balls
Steel or Cronidur rings
Open or sealed

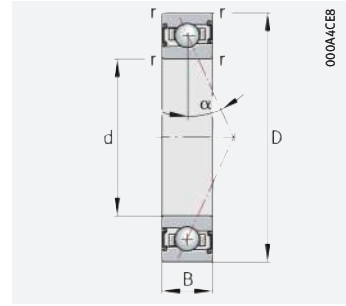
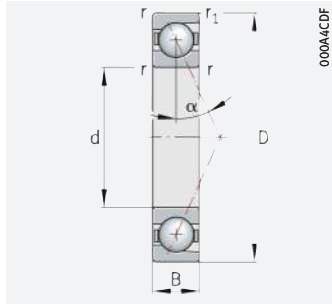

d = 80 – 80 mm

Main dimensions			Basic load ratings		Fatigue limit load C_{ur} N	Limiting speeds ¹⁾		Dimensions		Contact angle α °	Mass m ≈ kg	Designation ²⁾³⁾
d	D	B	dyn. C_r kN	stat. C_{0r} kN		n_G grease min ⁻¹	n_G oil ⁵⁾ min ⁻¹	r	r_1			
							min.	min.				
80	110	16	33,5	24	2 470	11 000	17 000	1	1	25	0,366	B71916-E-T-P4S
	110	16	35,5	25,5	2 600	12 000	19 000	1	1	15	0,366	B71916-C-T-P4S
	110	16	33,5	23	1 750	15 000	24 000	1	1	25	0,31	HCB71916-E-T-P4S
	110	16	19,2	14,6	1 500	15 000	24 000	1	1	25	0,379	HS71916-E-T-P4S
	110	16	20,3	15,5	1 590	17 000	26 000	1	1	15	0,379	HS71916-C-T-P4S
	110	16	35,5	24,3	1 850	17 000	26 000	1	1	15	0,309	HCB71916-C-T-P4S
	110	16	19,2	14	1 060	19 000	30 000	1	1	25	0,355	HC71916-E-T-P4S
	110	16	29,5	14	1 060	22 000	32 000	1	1	25	0,355	XC71916-E-T-P4S
	125	22	61	39	3 950	10 000	15 000	1,1	1,1	25	0,84	B7016-E-T-P4S
	125	22	64	41	4 150	11 000	17 000	1,1	1,1	15	0,84	B7016-C-T-P4S
	125	22	28,5	20,6	2 100	14 000	22 000	1,1	1,1	25	0,925	HS7016-E-T-P4S
	125	22	61	37,5	2 800	14 000	22 000	1,1	1,1	25	0,7	HCB7016-E-T-P4S
	125	22	30,5	21,8	2 220	15 000	24 000	1,1	1,1	15	0,927	HS7016-C-T-P4S
	125	22	64	39	2 950	15 000	24 000	1,1	1,1	15	0,7	HCB7016-C-T-P4S
	125	22	28,5	19,7	1 480	18 000	28 000	1,1	1,1	25	0,87	HC7016-E-T-P4S
	125	22	44	19,7	1 480	20 000	30 000	1,1	1,1	25	0,87	XC7016-E-T-P4S
	140	26	89	52	5 100	9 000	15 000	2	2	25	1,42	B7216-E-T-P4S
	140	26	94	55	5 400	10 000	17 000	2	2	15	1,43	B7216-C-T-P4S
	140	26	89	50	3 600	11 000	18 000	2	2	25	1,18	HCB7216-E-T-P4S
	140	26	94	52	3 800	12 000	19 000	2	2	15	1,18	HCB7216-C-T-P4S

medias ► <https://www.schaeffler.de/std/1DC6>

- 1) The limiting speeds are based on elastically preloaded single bearings.
- 2) Explanation of designations ► [SP 1](#).
- 3) The bearings are also available with gap seals (type HSS, HCS, XCS or suffix 2RSD).
Ordering examples: B7000-C-2RSD-T-P4S-UL and HSS7000-E-T-P4S-UL.
- 4) L = light preload; M = moderate preload; H = high preload.
- 5) Minimal quantity oil lubrication.

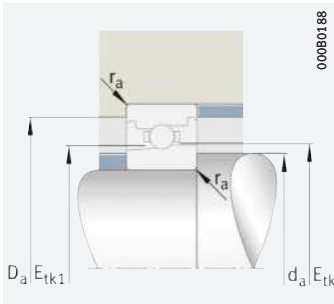

Mounting dimensions

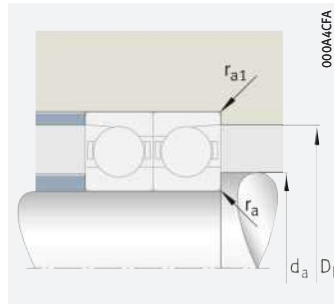

Mounting dimensions

d	Mounting dimensions							Preload force ⁴⁾ F _V			Lift-off force ⁴⁾ K _{aE}			Axial rigidity ⁴⁾ c _a		
	d _a h12	D _a H12	r _a max.	r _{a1} max.	E _{tk} min.	E _{tk1} min.	E _{tk} E _{tk1} max.	L	M	H	L	M	H	L	M	H
										N	N	N	N	N	N	N
80	86	104	0,6	0,3	89,3	89,3	92,2	237	908	1955	686	2718	6043	160	265	362
	86	104	0,6	0,3	89,3	89,3	92,2	174	591	1206	532	1954	4257	69,9	121	173
	86	104	0,6	0,3	89,3	89,3	92,2	95	459	1049	273	1344	3137	132	230	315
	86	104	0,6	0,3	91	88,5	92,5	113	338	676	325	992	2023	130	194	252
	86	104	0,6	0,3	91	88,5	92,5	71	213	426	212	666	1385	52,3	81,9	112
	86	104	0,6	0,3	89,3	89,3	92,2	84	321	686	249	1004	2259	58,8	101	143
	86	104	0,6	0,3	91	88,5	92,5	79	236	473	226	686	1392	130	192	248
	86	104	0,6	0,3	91	88,5	92,5	79	236	473	226	686	1392	130	192	248
	88	117	1	0,6	94	94	98,8	525	1816	3796	1528	5469	11813	201	321	435
	88	117	1	0,6	94	94	98,8	354	1138	2277	1091	3797	8119	85,7	145	207
	88	117	1	0,6	97,3	94	99,7	173	518	1035	497	1521	3103	148	220	286
	88	117	1	0,6	94	94	98,8	252	977	2113	726	2872	6354	175	284	383
	88	117	1	0,6	97,3	94	99,7	106	317	633	315	991	2063	58,7	92	126
	88	117	1	0,6	94	94	98,8	186	640	1327	554	2020	4415	74	123	173
	88	117	1	0,6	97,3	94	99,7	117	352	704	336	1023	2075	146	215	278
	88	117	1	0,6	97,3	94	99,7	117	352	704	336	1023	2075	146	215	278
	91	129	2	1	100,5	100,5	105,3	833	2764	5699	2433	8347	17799	221	349	472
	91	129	2	1	100,5	100,5	105,3	549	1721	3412	1701	5781	12250	94,1	159	226
	91	129	2	1	100,5	100,5	105,3	428	1527	3225	1232	4498	9728	196	312	416
	91	129	2	1	100,5	100,5	105,3	293	968	1979	876	3068	6618	81,5	134	187





Super precision angular contact ball bearings

With large or small balls
Steel or ceramic balls
Steel or Cronidur rings
Open or sealed

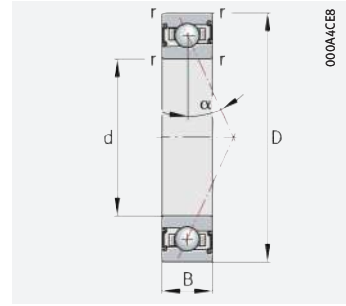
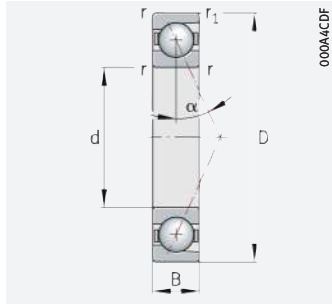

d = 85 – 85 mm

Main dimensions	Basic load ratings		Fatigue limit load	Limiting speeds ¹⁾		Dimensions		Contact angle	Mass	Designation ²⁾³⁾			
	d	D		B	dyn. C _r kN	stat. C _{0r} kN	C _{ur} N				n _G grease min ⁻¹	n _G oil ⁵⁾ min ⁻¹	r
85	120	18	18	44,5	31,5	3 200	10 000	15 000	1,1	1,1	25	0,53	B71917-E-T-P4S
	120	18	18	47	33,5	3 400	11 000	17 000	1,1	1,1	15	0,53	B71917-C-T-P4S
	120	18	18	20	16	1 630	14 000	22 000	1,1	1,1	25	0,571	HS71917-E-T-P4S
	120	18	18	44,5	30	2 270	14 000	22 000	1,1	1,1	25	0,44	HCB71917-E-T-P4S
	120	18	18	21,2	17	1 720	15 000	24 000	1,1	1,1	15	0,572	HS71917-C-T-P4S
	120	18	18	47	32	2 400	15 000	24 000	1,1	1,1	15	0,44	HCB71917-C-T-P4S
	120	18	18	20	15,3	1 150	18 000	28 000	1,1	1,1	25	0,545	HC71917-E-T-P4S
	120	18	18	30,5	15,3	1 150	20 000	30 000	1,1	1,1	25	0,545	XC71917-E-T-P4S
	130	22	22	63	41,5	4 100	9 500	15 000	1,1	1,1	25	0,88	B7017-E-T-P4S
	130	22	22	66	43,5	4 300	11 000	16 000	1,1	1,1	15	0,88	B7017-C-T-P4S
	130	22	22	29	21,4	2 130	13 000	20 000	1,1	1,1	25	0,969	HS7017-E-T-P4S
	130	22	22	63	39,5	2 900	13 000	20 000	1,1	1,1	25	0,74	HCB7017-E-T-P4S
	130	22	22	30,5	22,7	2 250	15 000	22 000	1,1	1,1	15	0,97	HS7017-C-T-P4S
	130	22	22	66	41,5	3 050	15 000	22 000	1,1	1,1	15	0,74	HCB7017-C-T-P4S
	130	22	22	29	20,5	1 510	17 000	26 000	1,1	1,1	25	0,913	HC7017-E-T-P4S
	130	22	22	44,5	20,5	1 510	19 000	30 000	1,1	1,1	25	0,913	XC7017-E-T-P4S
	150	28	28	93	57	5 400	8 000	13 000	2	2	25	1,81	B7217-E-T-P4S
	150	28	28	97	59	5 600	9 000	15 000	2	2	15	1,82	B7217-C-T-P4S
	150	28	28	93	54	3 800	10 000	17 000	2	2	25	1,55	HCB7217-E-T-P4S
	150	28	28	97	57	4 000	11 000	18 000	2	2	15	1,55	HCB7217-C-T-P4S

medias ► <https://www.schaeffler.de/std/1DC7>

- 1) The limiting speeds are based on elastically preloaded single bearings.
- 2) Explanation of designations ► SP 1.
- 3) The series 719 and 70 are also available with gap seals (type HSS, HCS, XCS or suffix 2RSD).
Ordering examples: B7000-C-2RSD-T-P4S-UL and HSS7000-E-T-P4S-UL.
- 4) L = light preload; M = moderate preload; H = high preload.
- 5) Minimal quantity oil lubrication.

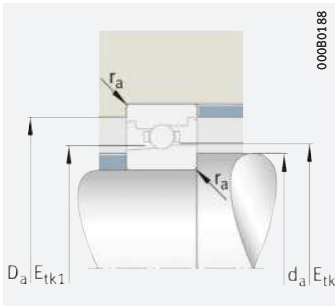

Mounting dimensions

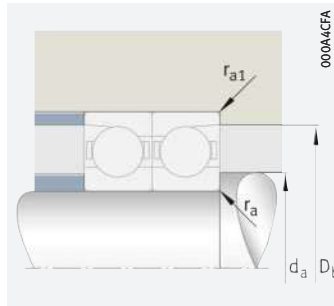

Mounting dimensions

d	Mounting dimensions							Preload force ⁴⁾ F _V			Lift-off force ⁴⁾ K _{aE}			Axial rigidity ⁴⁾ c _a		
	d _a h12	D _a H12	r _a max.	r _{a1} max.	E _{tk} min.	E _{tk1} min.	E _{tk} E _{tk1} max.	L	M	H	L	M	H	L	M	H
								N	N	N	N	N	N	N/μm	N/μm	N/μm
85	92	114	0,6	0,6	95,9	95,9	99,3	333	1 226	2 609	968	3 675	8 074	184	301	409
	92	114	0,6	0,6	95,9	95,9	99,3	237	788	1 597	726	2 609	5 644	79,7	136	195
	92	114	0,6	0,6	98,5	96	99,9	117	352	704	338	1 032	2 102	140	208	270
	92	114	0,6	0,6	95,9	95,9	99,3	143	627	1 403	409	1 837	4 197	154	262	356
	92	114	0,6	0,6	98,5	96	99,9	74	221	442	220	689	1 433	55,9	87,4	119
	92	114	0,6	0,6	95,9	95,9	99,3	117	428	906	346	1 341	2 985	67,4	114	161
	92	114	0,6	0,6	98,5	96	99,9	82	247	493	236	716	1 452	140	206	265
	92	114	0,6	0,6	98,5	96	99,9	82	247	493	236	716	1 452	140	206	265
	93	122	1	0,6	99	99	103,8	540	1 874	3 919	1 573	5 639	12 184	209	336	454
	93	122	1	0,6	99	99	103,8	367	1 183	2 368	1 132	3 942	8 434	89,7	152	217
	93	122	1	0,6	102,3	99	104,7	173	518	1 035	497	1 520	3 099	151	224	292
	93	122	1	0,6	99	99	103,8	256	997	2 159	736	2 927	6 484	181	296	398
	93	122	1	0,6	102,3	99	104,7	107	322	643	320	1 006	2 093	60,3	94,4	129
	93	122	1	0,6	99	99	103,8	189	653	1 356	562	2 058	4 501	76,9	128	179
	93	122	1	0,6	102,3	99	104,7	120	359	718	343	1 042	2 115	150	221	286
	93	122	1	0,6	102,3	99	104,7	120	359	718	343	1 042	2 115	150	221	286
	98	138	2	1	106,6	106,6	113,2	864	2 869	5 921	2 520	8 657	18 466	233	369	497
	98	138	2	1	106,6	106,6	113,2	568	1 786	3 544	1 759	5 983	12 688	99,1	167	238
	98	138	2	1	106,6	106,6	113,2	438	1 572	3 325	1 262	4 626	10 015	206	328	438
	98	138	2	1	106,6	106,6	113,2	306	1 012	2 071	915	3 205	6 915	86,2	142	198





Super precision angular contact ball bearings

- With large or small balls
- Steel or ceramic balls
- Steel or Cronidur rings
- Open or sealed

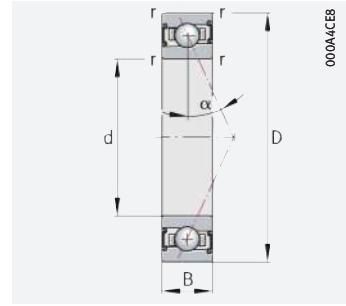
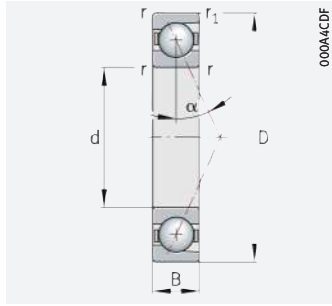

d = 90 – 90 mm

Main dimensions	Basic load ratings		Fatigue limit load		Limiting speeds ¹⁾		Dimensions		Contact angle	Mass	Designation ²⁾³⁾	
					C _{ur}	n _G grease	n _G oil ⁵⁾	r				r ₁
90	125	18	45	33	3 300	9 500	15 000	1,1	1,1	25	0,55	B71918-E-T-P4S
	125	18	48	35	3 450	11 000	16 000	1,1	1,1	15	0,55	B71918-C-T-P4S
	125	18	21,9	17,7	1 750	13 000	20 000	1,1	1,1	25	0,579	HS71918-E-T-P4S
	125	18	45	31,5	2 330	13 000	20 000	1,1	1,1	25	0,462	HCB71918-E-T-P4S
	125	18	23,2	18,7	1 860	15 000	22 000	1,1	1,1	15	0,58	HS71918-C-T-P4S
	125	18	48	33,5	2 460	15 000	22 000	1,1	1,1	15	0,461	HCB71918-C-T-P4S
	125	18	21,9	16,9	1 240	17 000	26 000	1,1	1,1	25	0,564	HC71918-E-T-P4S
	125	18	33,5	16,9	1 240	19 000	30 000	1,1	1,1	25	0,564	XC71918-E-T-P4S
	140	24	74	48,5	4 650	9 000	14 000	1,5	1,5	25	1,14	B7018-E-T-P4S
	140	24	78	51	4 900	10 000	15 000	1,5	1,5	15	1,14	B7018-C-T-P4S
	140	24	34	25	2 410	12 000	19 000	1,5	1,5	25	1,27	HS7018-E-T-P4S
	140	24	74	46,5	3 300	12 000	19 000	1,5	1,5	25	0,95	HCB7018-E-T-P4S
	140	24	36	26,5	2 550	14 000	22 000	1,5	1,5	15	1,27	HS7018-C-T-P4S
	140	24	78	49	3 450	14 000	22 000	1,5	1,5	15	0,95	HCB7018-C-T-P4S
	140	24	34	24	1 710	16 000	24 000	1,5	1,5	25	1,19	HC7018-E-T-P4S
	140	24	52	24	1 710	18 000	28 000	1,5	1,5	25	1,19	XC7018-E-T-P4S
	160	30	119	72	6 600	7 500	12 000	2	2	25	2,19	B7218-E-T-P4S
	160	30	125	75	6 900	8 500	14 000	2	2	15	2,2	B7218-C-T-P4S
	160	30	119	69	4 650	9 000	15 000	2	2	25	1,79	HCB7218-E-T-P4S
	160	30	125	72	4 900	11 000	18 000	2	2	15	1,8	HCB7218-C-T-P4S

medias ► <https://www.schaeffler.de/std/1DC8>

- 1) The limiting speeds are based on elastically preloaded single bearings.
- 2) Explanation of designations ► SP 1.
- 3) The series 719 and 70 are also available with gap seals (type HSS, HCS, XCS or suffix 2RSD).
Ordering examples: B7000-C-2RSD-T-P4S-UL and HSS7000-E-T-P4S-UL.
- 4) L = light preload; M = moderate preload; H = high preload.
- 5) Minimal quantity oil lubrication.

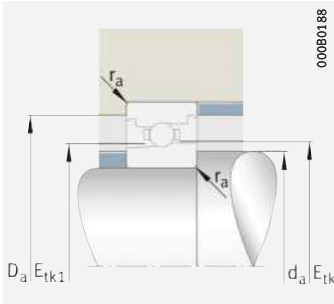

Mounting dimensions

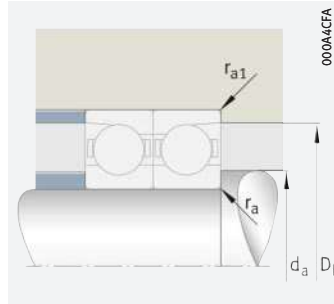

Mounting dimensions

d	Mounting dimensions							Preload force ⁴⁾ F _V			Lift-off force ⁴⁾ K _{aE}			Axial rigidity ⁴⁾ c _a		
	d _a h12	D _a H12	r _a max.	r _{a1} max.	E _{tk} min.	E _{tk1} min.	E _{tk} E _{tk1} max.	L	M	H	L	M	H	L	M	H
								N	N	N	N	N	N	N/μm	N/μm	N/μm
90	97	119	0,6	0,6	100,9	100,9	104,3	334	1 236	2 634	970	3 701	8 140	189	309	420
	97	119	0,6	0,6	100,9	100,9	104,3	238	796	1 615	729	2 628	5 691	81,8	140	200
	97	119	0,6	0,6	103,2	100,6	104,8	129	386	773	371	1 133	2 309	144	214	279
	97	119	0,6	0,6	100,9	100,9	104,3	147	648	1 450	421	1 897	4 337	160	272	369
	97	119	0,6	0,6	103,2	100,6	104,8	79	237	474	235	739	1 536	57,2	89,4	122
	97	119	0,6	0,6	100,9	100,9	104,3	118	434	919	349	1 357	3 023	69,4	118	165
	97	119	0,6	0,6	103,2	100,6	104,8	90	269	538	257	781	1 584	144	212	273
	97	119	0,6	0,6	103,2	100,6	104,8	90	269	538	257	781	1 584	144	212	273
	100	131	1,5	0,6	105,5	105,5	110,9	646	2 205	4 590	1 880	6 636	14 269	223	355	479
	100	131	1,5	0,6	105,5	105,5	110,9	437	1 395	2 785	1 347	4 651	9 920	95,2	161	229
	100	131	1,5	0,6	109,3	105,7	111,9	204	612	1 225	588	1 799	3 667	164	244	318
	100	131	1,5	0,6	105,5	105,5	110,9	319	1 201	2 577	916	3 528	7 745	195	316	423
	100	131	1,5	0,6	109,3	105,7	111,9	126	377	754	375	1 178	2 451	65,4	102	140
	100	131	1,5	0,6	105,5	105,5	110,9	230	781	1 613	685	2 464	5 361	82,3	136	191
	100	131	1,5	0,6	109,3	105,7	111,9	141	423	845	404	1 228	2 490	163	241	310
	100	131	1,5	0,6	109,3	105,7	111,9	141	423	845	404	1 228	2 490	163	241	310
104	147	2	1	112,1	112,1	120	1 127	3 689	7 575	3 291	11 132	23 627	257	404	545	
104	147	2	1	112,1	112,1	120	732	2 280	4 513	2 267	7 640	16 156	109	183	260	
104	147	2	1	112,1	112,1	120	586	2 042	4 283	1 688	6 013	12 905	230	361	481	
104	147	2	1	112,1	112,1	120	400	1 303	2 655	1 197	4 129	8 866	95,2	156	217	





Super precision angular contact ball bearings

With large or small balls
Steel or ceramic balls
Steel or Cronidur rings
Open or sealed

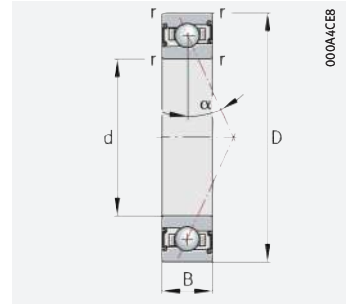
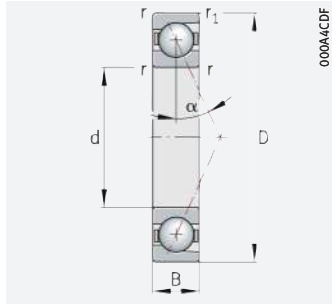

d = 95 – 95 mm

Main dimensions	Basic load ratings		Fatigue limit load	Limiting speeds ¹⁾		Dimensions		Contact angle	Mass	Designation ²⁾³⁾			
	d	D		B	dyn. C _r kN	stat. C _{0r} kN	C _{ur} N				n _G grease min ⁻¹	n _G oil ⁵⁾ min ⁻¹	r
95	130	18	18	46	34,5	3 350	9 000	14 000	1,1	1,1	25	0,58	B71919-E-T-P4S
	130	18	18	48,5	36,5	3 550	10 000	16 000	1,1	1,1	15	0,58	B71919-C-T-P4S
	130	18	18	22,5	18,7	1 820	13 000	19 000	1,1	1,1	25	0,605	HS71919-E-T-P4S
	130	18	18	46	33	2 380	13 000	19 000	1,1	1,1	25	0,483	HCB71919-E-T-P4S
	130	18	18	23,9	19,9	1 930	14 000	22 000	1,1	1,1	15	0,606	HS71919-C-T-P4S
	130	18	18	48,5	35	2 500	14 000	22 000	1,1	1,1	15	0,482	HCB71919-C-T-P4S
	130	18	18	22,5	17,9	1 290	16 000	24 000	1,1	1,1	25	0,59	HC71919-E-T-P4S
	130	18	18	34,5	17,9	1 290	18 000	28 000	1,1	1,1	25	0,59	XC71919-E-T-P4S
	145	24	24	77	52	4 850	8 500	13 000	1,5	1,5	25	1,19	B7019-E-T-P4S
	145	24	24	81	54	5 100	9 500	15 000	1,5	1,5	15	1,19	B7019-C-T-P4S
	145	24	24	34	26	2 450	12 000	18 000	1,5	1,5	25	1,32	HS7019-E-T-P4S
	145	24	24	77	49,5	3 450	12 000	18 000	1,5	1,5	25	1	HCB7019-E-T-P4S
	145	24	24	36,5	27,5	2 600	13 000	20 000	1,5	1,5	15	1,32	HS7019-C-T-P4S
	145	24	24	81	52	3 600	13 000	20 000	1,5	1,5	15	1	HCB7019-C-T-P4S
	145	24	24	34	25	1 730	15 000	24 000	1,5	1,5	25	1,24	HC7019-E-T-P4S
	145	24	24	52	25	1 730	17 000	26 000	1,5	1,5	25	1,24	XC7019-E-T-P4S
	170	32	32	124	78	6 900	7 000	11 000	2,1	2,1	25	2,72	B7219-E-T-P4S
	170	32	32	130	81	7 300	8 000	13 000	2,1	2,1	15	2,73	B7219-C-T-P4S
	170	32	32	124	74	4 900	8 500	14 000	2,1	2,1	25	2,29	HCB7219-E-T-P4S
	170	32	32	130	78	5 200	10 000	17 000	2,1	2,1	15	2,3	HCB7219-C-T-P4S

medias ► <https://www.schaeffler.de/std/1DC9>

- 1) The limiting speeds are based on elastically preloaded single bearings.
- 2) Explanation of designations ► SP 1.
- 3) The series 719 and 70 are also available with gap seals (type HSS, HCS, XCS or suffix 2RSD).
Ordering examples: B7000-C-2RSD-T-P4S-UL and HSS7000-E-T-P4S-UL.
- 4) L = light preload; M = moderate preload; H = high preload.
- 5) Minimal quantity oil lubrication.

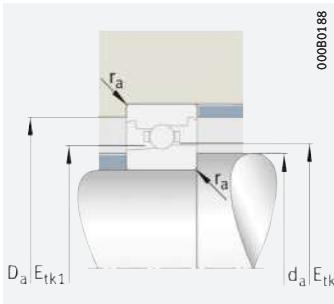

Mounting dimensions

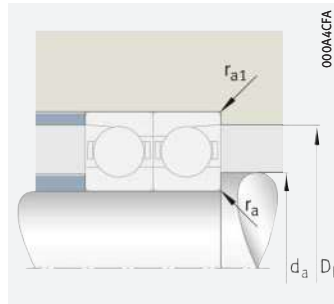

Mounting dimensions

d	Mounting dimensions							Preload force ⁴⁾ F _V			Lift-off force ⁴⁾ K _{aE}			Axial rigidity ⁴⁾ c _a		
	d _a h12	D _a H12	r _a	r _{a1}	E _{tk}	E _{tk1}	E _{tk} E _{tk1}	L	M	H	L	M	H	L	M	H
			max.	max.	min.	min.	max.	N	N	N	N	N	N	N/μm	N/μm	N/μm
95	102	124	0,6	0,6	105,9	105,9	109,2	341	1 262	2 693	988	3 777	8 313	196	319	434
	102	124	0,6	0,6	105,9	105,9	109,2	243	813	1 651	743	2 679	5 806	84,4	144	206
	102	124	0,6	0,6	108,2	105,6	109,7	131	393	787	377	1 153	2 347	150	223	290
	102	124	0,6	0,6	105,9	105,9	109,2	148	656	1 470	423	1 918	4 393	164	280	380
	102	124	0,6	0,6	108,2	105,6	109,7	82	246	492	244	766	1 593	60	93,7	127
	102	124	0,6	0,6	105,9	105,9	109,2	119	440	932	352	1 373	3 061	71,3	121	170
	102	124	0,6	0,6	108,2	105,6	109,7	92	276	552	263	801	1 623	150	221	285
	102	124	0,6	0,6	108,2	105,6	109,7	92	276	552	263	801	1 623	150	221	285
	105	136	1,5	0,6	110,5	110,5	115,8	671	2 295	4 780	1 955	6 904	14 849	233	372	502
	105	136	1,5	0,6	110,5	110,5	115,8	444	1 421	2 842	1 367	4 726	10 091	98,8	167	237
	105	136	1,5	0,6	114,3	110,7	116,8	204	612	1 225	588	1 797	3 663	168	249	324
	105	136	1,5	0,6	110,5	110,5	115,8	322	1 220	2 622	924	3 581	7 871	203	328	439
	105	136	1,5	0,6	114,3	110,7	116,8	127	382	764	380	1 192	2 480	67	105	143
	105	136	1,5	0,6	110,5	110,5	115,8	233	794	1 643	693	2 499	5 442	85,3	141	197
	105	136	1,5	0,6	114,3	110,7	116,8	141	423	845	404	1 227	2 488	167	246	317
	105	136	1,5	0,6	114,3	110,7	116,8	141	423	845	404	1 227	2 488	167	246	317
	110,5	154	2,1	1	119,1	119,1	126,9	1 184	3 876	7 964	3 454	11 693	24 820	273	429	577
	110,5	154	2,1	1	119,1	119,1	126,9	760	2 373	4 703	2 353	7 935	16 792	115	193	273
	110,5	154	2,1	1	119,1	119,1	126,9	605	2 113	4 437	1 741	6 219	13 355	242	381	507
	110,5	154	2,1	1	119,1	119,1	126,9	413	1 348	2 748	1 234	4 261	9 153	100	164	228





Super precision angular contact ball bearings

With large or small balls
Steel or ceramic balls
Steel or Cronidur rings
Open or sealed

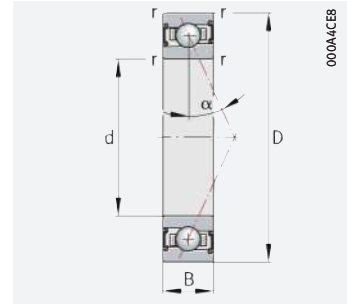
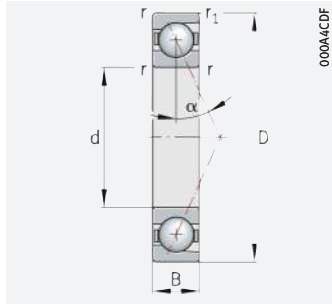

d = 100 – 100 mm

Main dimensions			Basic load ratings		Fatigue limit load C_{ur} N	Limiting speeds ¹⁾		Dimensions		Contact angle α °	Mass m ≈ kg	Designation ²⁾³⁾
d	D	B	dyn. C_r kN	stat. C_{0r} kN		n_G grease min ⁻¹	n_G oil ⁵⁾ min ⁻¹	r	r_1			
100	140	20	57	42,5	3 950	8 500	13 000	1,1	1,1	25	0,78	B71920-E-T-P4S
	140	20	60	45	4 200	9 500	14 000	1,1	1,1	15	0,78	B71920-C-T-P4S
	140	20	27	22,1	2 080	12 000	18 000	1,1	1,1	25	0,86	HS71920-E-T-P4S
	140	20	57	40,5	2 800	12 000	18 000	1,1	1,1	25	0,65	HCB71920-E-T-P4S
	140	20	28,5	23,5	2 200	13 000	20 000	1,1	1,1	15	0,86	HS71920-C-T-P4S
	140	20	60	43	2 950	13 000	20 000	1,1	1,1	15	0,65	HCB71920-C-T-P4S
	140	20	27	21,2	1 470	15 000	24 000	1,1	1,1	25	0,81	HC71920-E-T-P4S
	140	20	41	21,2	1 470	17 000	26 000	1,1	1,1	25	0,81	XC71920-E-T-P4S
	150	24	79	55	5 000	8 000	13 000	1,5	1,5	25	1,24	B7020-E-T-P4S
	150	24	83	57	5 300	9 000	14 000	1,5	1,5	15	1,24	B7020-C-T-P4S
	150	24	34,5	27	2 490	11 000	17 000	1,5	1,5	25	1,38	HS7020-E-T-P4S
	150	24	79	52	3 550	11 000	17 000	1,5	1,5	25	1,03	HCB7020-E-T-P4S
	150	24	36,5	28,5	2 650	13 000	19 000	1,5	1,5	15	1,38	HS7020-C-T-P4S
	150	24	83	55	3 750	13 000	19 000	1,5	1,5	15	1,03	HCB7020-C-T-P4S
	150	24	34,5	26	1 760	15 000	22 000	1,5	1,5	25	1,29	HC7020-E-T-P4S
	150	24	53	26	1 760	16 000	24 000	1,5	1,5	25	1,29	XC7020-E-T-P4S
	180	34	129	84	7 300	6 700	10 000	2,1	2,1	25	3,34	B7220-E-T-P4S
	180	34	135	88	7 600	7 500	12 000	2,1	2,1	15	3,35	B7220-C-T-P4S
180	34	129	80	5 100	8 000	13 000	2,1	2,1	25	2,88	HCB7220-E-T-P4S	
180	34	135	84	5 400	9 500	16 000	2,1	2,1	15	2,89	HCB7220-C-T-P4S	

medias ► <https://www.schaeffler.de/std/1DCA>

- 1) The limiting speeds are based on elastically preloaded single bearings.
- 2) Explanation of designations ► SP 1.
- 3) The series 719 and 70 are also available with gap seals (type HSS, HCS, XCS or suffix 2RSD).
Ordering examples: B7000-C-2RSD-T-P4S-UL and HSS7000-E-T-P4S-UL.
- 4) L = light preload; M = moderate preload; H = high preload.
- 5) Minimal quantity oil lubrication.

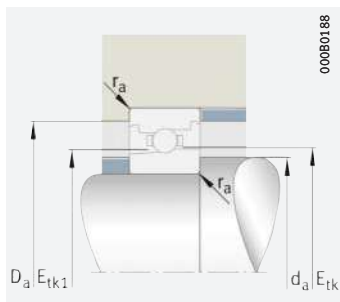

Mounting dimensions

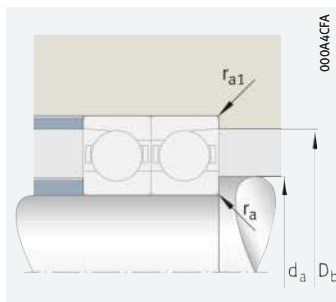

Mounting dimensions

d	Mounting dimensions							Preload force ⁴⁾ F _V			Lift-off force ⁴⁾ K _{aE}			Axial rigidity ⁴⁾ c _a		
	d _a h12	D _a H12	r _a	r _{a1}	E _{tk}	E _{tk1}	E _{tk} E _{tk1} max.	L	M	H	L	M	H	L	M	H
			max.	max.	min.	min.	max.	N	N	N	N	N	N	N/μm	N/μm	N/μm
100	107	133	0,6	0,6	113,4	113,4	117,5	450	1 616	3 417	1 305	4 839	10 556	219	353	479
	107	133	0,6	0,6	113,4	113,4	117,5	316	1 040	2 101	968	3 432	7 399	94,1	160	228
	107	133	0,6	0,6	115,2	112,3	116,9	158	474	949	455	1 390	2 832	163	242	314
	107	133	0,6	0,6	113,4	113,4	117,5	204	850	1 876	584	2 489	5 611	187	311	421
	107	133	0,6	0,6	115,2	112,3	116,9	97	291	583	289	906	1 883	64,6	101	137
	107	133	0,6	0,6	113,4	113,4	117,5	160	572	1 201	473	1 789	3 950	80,4	135	189
	107	133	0,6	0,6	115,2	112,3	116,9	109	328	656	313	951	1 927	162	239	307
	107	133	0,6	0,6	115,2	112,3	116,9	109	328	656	313	951	1 927	162	239	307
	110	141	1,5	0,6	115,5	115,5	120,8	681	2 336	4 869	1 982	7 018	15 103	242	385	521
	110	141	1,5	0,6	115,5	115,5	120,8	464	1 484	2 970	1 427	4 935	10 539	104	175	248
	110	141	1,5	0,6	119,3	115,7	121,8	207	621	1 242	596	1 822	3 713	172	256	333
	110	141	1,5	0,6	115,5	115,5	120,8	333	1 266	2 723	957	3 715	8 170	212	343	459
	110	141	1,5	0,6	119,3	115,7	121,8	127	382	764	379	1 190	2 476	68,3	107	145
	110	141	1,5	0,6	115,5	115,5	120,8	241	823	1 703	717	2 587	5 636	89,1	148	206
	110	141	1,5	0,6	119,3	115,7	121,8	144	431	863	412	1 252	2 539	171	253	326
	110	141	1,5	0,6	119,3	115,7	121,8	144	431	863	412	1 252	2 539	171	253	326
	114,5	165,5	2,1	1	126,6	126,6	134,4	1 208	3 964	8 152	3 521	11 940	25 355	285	449	604
	114,5	165,5	2,1	1	126,6	126,6	134,4	789	2 466	4 892	2 439	8 230	17 428	121	203	287
	114,5	165,5	2,1	1	126,6	126,6	134,4	627	2 198	4 619	1 806	6 466	13 894	255	402	535
	114,5	165,5	2,1	1	126,6	126,6	134,4	428	1 400	2 856	1 279	4 420	9 498	106	172	240





Super precision angular contact ball bearings

With large or small balls
Steel or ceramic balls
Steel or Cronidur rings
Open or sealed

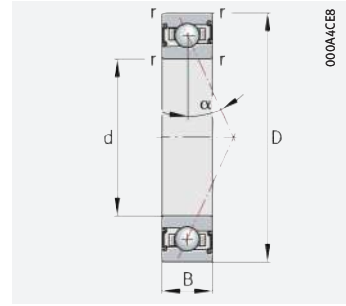
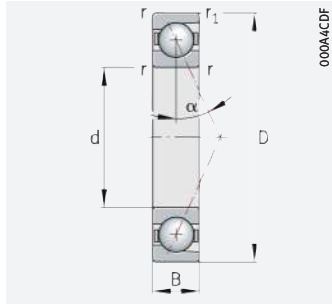

d = 105 – 105 mm

Main dimensions			Basic load ratings		Fatigue limit load C_{Ur} N	Limiting speeds ¹⁾		Dimensions		Contact angle α °	Mass m ≈ kg	Designation ²⁾³⁾
d	D	B	dyn. C_r kN	stat. C_{Or} kN		n_G grease min ⁻¹	n_G oil ⁵⁾ min ⁻¹	r	r_1			
105	145	20	57	42,5	3 900	8 000	13 000	1,1	1,1	25	0,81	B71921-E-T-P4S
	145	20	60	45	4 150	9 000	14 000	1,1	1,1	15	0,81	B71921-C-T-P4S
	145	20	27,5	23,4	2 150	11 000	17 000	1,1	1,1	25	0,89	HS71921-E-T-P4S
	145	20	57	41	2 800	11 000	17 000	1,1	1,1	25	0,69	HCB71921-E-T-P4S
	145	20	29	24,8	2 280	13 000	19 000	1,1	1,1	15	0,89	HS71921-C-T-P4S
	145	20	60	43	2 950	13 000	19 000	1,1	1,1	15	0,69	HCB71921-C-T-P4S
	145	20	27,5	22,4	1 530	15 000	22 000	1,1	1,1	25	0,83	HC71921-E-T-P4S
	145	20	42	22,4	1 530	16 000	24 000	1,1	1,1	25	0,83	XC71921-E-T-P4S
	160	26	80	58	5 200	7 500	12 000	2	2	25	1,6	B7021-E-T-P4S
	160	26	85	61	5 400	8 500	13 000	2	2	15	1,6	B7021-C-T-P4S
	160	26	45	34,5	3 050	11 000	16 000	2	2	25	1,7	HS7021-E-T-P4S
	160	26	80	55	3 650	11 000	16 000	2	2	25	1,39	HCB7021-E-T-P4S
	160	26	47,5	36,5	3 250	12 000	18 000	2	2	15	1,7	HS7021-C-T-P4S
	160	26	85	58	3 850	12 000	18 000	2	2	15	1,39	HCB7021-C-T-P4S
	160	26	45	33	2 180	14 000	22 000	2	2	25	1,59	HC7021-E-T-P4S
	160	26	69	33	2 180	15 000	24 000	2	2	25	1,59	XC7021-E-T-P4S
	190	36	156	99	8 400	6 300	9 500	2,1	2,1	25	3,88	B7221-E-T-P4S
	190	36	164	104	8 800	7 000	11 000	2,1	2,1	15	3,89	B7221-C-T-P4S
190	36	156	95	5 900	7 500	12 000	2,1	2,1	25	3,25	HCB7221-E-T-P4S	
190	36	164	99	6 200	9 000	15 000	2,1	2,1	15	3,26	HCB7221-C-T-P4S	

medias ► <https://www.schaeffler.de/std/1D66>

- 1) The limiting speeds are based on elastically preloaded single bearings.
- 2) Explanation of designations ► SP 1.
- 3) The series 719 and 70 are also available with gap seals (type HSS, HCS, XCS or suffix 2RSD).
Ordering examples: B7000-C-2RSD-T-P4S-UL and HSS7000-E-T-P4S-UL.
- 4) L = light preload; M = moderate preload; H = high preload.
- 5) Minimal quantity oil lubrication.

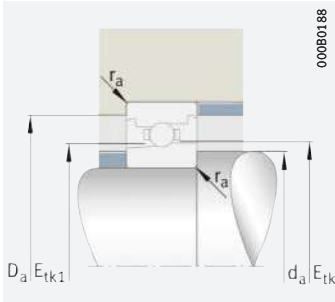

Mounting dimensions

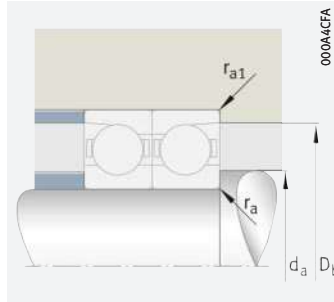

Mounting dimensions

d	Mounting dimensions							Preload force ⁴⁾ F _V			Lift-off force ⁴⁾ K _{aE}			Axial rigidity ⁴⁾ c _a		
	d _a h12	D _a H12	r _a	r _{a1}	E _{tk}	E _{tk1}	E _{tk} E _{tk1}	L	M	H	L	M	H	L	M	H
			max.	max.	min.	min.	max.	N	N	N	N	N	N	N/μm	N/μm	N/μm
105	112	138	0,6	0,6	117,4	117,4	121,4	450	1616	3417	1305	4839	10556	219	353	479
	112	138	0,6	0,6	117,4	117,4	121,4	316	1040	2101	968	3432	7399	94,1	160	228
	112	138	0,6	0,6	120,2	117,3	121,9	161	483	966	463	1414	2880	170	252	327
	112	138	0,6	0,6	117,4	117,4	121,4	204	850	1876	584	2489	5611	187	311	421
	112	138	0,6	0,6	120,2	117,3	121,9	101	302	603	299	937	1946	67,6	105	143
	112	138	0,6	0,6	117,4	117,4	121,4	157	564	1185	466	1763	3895	80	134	188
	112	138	0,6	0,6	120,2	117,3	121,9	113	338	676	323	980	1987	170	250	321
	112	138	0,6	0,6	120,2	117,3	121,9	113	338	676	323	980	1987	170	250	321
	116	150	2	1	123	123	128,3	691	2377	4959	2010	7133	15359	251	399	539
	116	150	2	1	123	123	128,3	471	1511	3027	1447	5010	10710	107	181	257
	116	150	2	1	125,8	121,7	129	267	802	1604	770	2354	4797	189	281	365
	116	150	2	1	123	123	128,3	336	1285	2768	966	3768	8297	219	355	476
	116	150	2	1	125,8	121,7	129	164	492	985	489	1536	3194	75	117	160
	116	150	2	1	123	123	128,3	244	836	1732	725	2623	5718	92,1	153	213
	116	150	2	1	125,8	121,7	129	184	552	1104	527	1602	3250	188	277	357
	116	150	2	1	125,8	121,7	129	184	552	1104	527	1602	3250	188	277	357
	120,5	174,5	2,1	1	132,2	132,2	141,2	1545	5006	10249	4508	15092	31918	312	488	656
	120,5	174,5	2,1	1	132,2	132,2	141,2	989	3069	6072	3060	10252	21655	131	219	311
	120,5	174,5	2,1	1	132,2	132,2	141,2	800	2742	5723	2303	8067	17220	278	434	577
	120,5	174,5	2,1	1	132,2	132,2	141,2	536	1733	3524	1603	5476	11721	114	186	258





Super precision angular contact ball bearings

With large or small balls
Steel or ceramic balls
Steel or Cronidur rings
Open or sealed

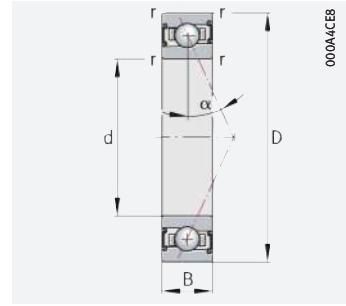
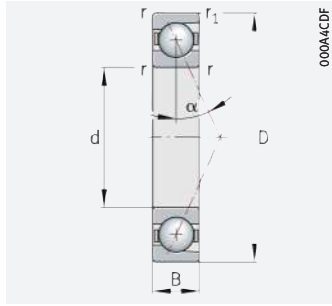

d = 110 – 110 mm

Main dimensions	Basic load ratings		Fatigue limit load	Limiting speeds ¹⁾		Dimensions		Contact angle	Mass	Designation ²⁾³⁾			
	d	D		B	dyn. C _r kN	stat. C _{0r} kN	C _{ur} N				n _G grease min ⁻¹	n _G oil ⁵⁾ min ⁻¹	r
110	150	20	20	58	44,5	4 000	8 000	12 000	1,1	1,1	25	0,85	B71922-E-T-P4S
	150	20	20	61	47	4 250	8 500	13 000	1,1	1,1	15	0,85	B71922-C-T-P4S
	150	20	20	32	27	2 430	11 000	17 000	1,1	1,1	25	0,91	HS71922-E-T-P4S
	150	20	20	58	42,5	2 850	11 000	17 000	1,1	1,1	25	0,71	HCB71922-E-T-P4S
	150	20	20	34	28,5	2 550	12 000	19 000	1,1	1,1	15	0,91	HS71922-C-T-P4S
	150	20	20	61	45	3 000	12 000	19 000	1,1	1,1	15	0,71	HCB71922-C-T-P4S
	150	20	20	32	26	1 720	14 000	22 000	1,1	1,1	25	0,84	HC71922-E-T-P4S
	150	20	20	49	26	1 720	16 000	24 000	1,1	1,1	25	0,84	XC71922-E-T-P4S
	170	28	28	106	73	6 400	7 500	12 000	2	2	25	1,95	B7022-E-T-P4S
	170	28	28	112	77	6 700	8 000	12 000	2	2	15	1,95	B7022-C-T-P4S
	170	28	28	45,5	35,5	3 100	11 000	16 000	2	2	25	2,17	HS7022-E-T-P4S
	170	28	28	106	70	4 500	11 000	16 000	2	2	25	1,62	HCB7022-E-T-P4S
	170	28	28	48	38	3 300	12 000	18 000	2	2	15	2,17	HS7022-C-T-P4S
	170	28	28	112	74	4 750	12 000	18 000	2	2	15	1,62	HCB7022-C-T-P4S
	170	28	28	45,5	34	2 200	13 000	20 000	2	2	25	2,05	HC7022-E-T-P4S
	170	28	28	69	34	2 200	14 000	22 000	2	2	25	2,05	XC7022-E-T-P4S
	200	38	38	156	100	8 300	6 000	9 000	2,1	2,1	25	4,59	B7222-E-T-P4S
	200	38	38	164	105	8 700	6 700	10 000	2,1	2,1	15	4,6	B7222-C-T-P4S
200	38	38	156	96	5 900	7 000	10 000	2,1	2,1	25	3,96	HCB7222-E-T-P4S	
200	38	38	164	101	6 200	8 500	14 000	2,1	2,1	15	3,97	HCB7222-C-T-P4S	

medias ► <https://www.schaeffler.de/std/1D67>

- 1) The limiting speeds are based on elastically preloaded single bearings.
- 2) Explanation of designations ► SP 1.
- 3) The series 719 and 70 are also available with gap seals (type HSS, HCS, XCS or suffix 2RSD).
Ordering examples: B7000-C-2RSD-T-P4S-UL and HSS7000-E-T-P4S-UL.
- 4) L = light preload; M = moderate preload; H = high preload.
- 5) Minimal quantity oil lubrication.

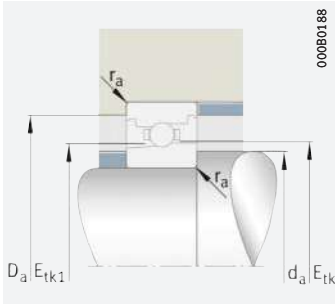

Mounting dimensions

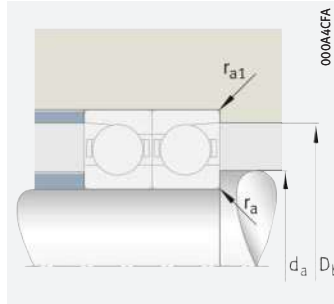

Mounting dimensions

d	Mounting dimensions							Preload force ⁴⁾ F _V			Lift-off force ⁴⁾ K _{aE}			Axial rigidity ⁴⁾ c _a		
	d _a h12	D _a H12	r _a	r _{a1}	E _{tk}	E _{tk1}	E _{tk} E _{tk1}	L	M	H	L	M	H	L	M	H
			max.	max.	min.	min.	max.	N	N	N	N	N	N	N/μm	N/μm	N/μm
110	117	143	0,6	0,6	122,4	122,4	126,4	455	1 642	3 475	1 321	4 913	10 722	225	364	493
	117	143	0,6	0,6	122,4	122,4	126,4	314	1 038	2 102	961	3 415	7 373	96,1	163	232
	117	143	0,6	0,6	124,8	121,5	126,9	187	561	1 121	538	1 642	3 344	178	264	343
	117	143	0,6	0,6	122,4	122,4	126,4	208	871	1 923	596	2 547	5 747	193	322	435
	117	143	0,6	0,6	124,8	121,5	126,9	116	347	693	344	1 077	2 238	70,6	110	149
	117	143	0,6	0,6	122,4	122,4	126,4	158	570	1 199	468	1 777	3 931	82,1	138	193
	117	143	0,6	0,6	124,8	121,5	126,9	131	393	787	375	1 141	2 312	178	262	337
	117	143	0,6	0,6	124,8	121,5	126,9	131	393	787	375	1 141	2 312	178	262	337
	121	159	2	1	128,6	128,6	135,1	968	3 242	6 709	2 820	9 745	20 814	280	443	596
	121	159	2	1	128,6	128,6	135,1	643	2 033	4 052	1 981	6 757	14 370	119	200	283
	121	159	2	1	133,3	129,2	136,5	267	802	1 604	770	2 352	4 792	193	287	373
	121	159	2	1	128,6	128,6	135,1	490	1 779	3 778	1 409	5 224	11 341	248	395	527
	121	159	2	1	133,3	129,2	136,5	168	503	1 005	499	1 566	3 257	77,2	121	164
	121	159	2	1	128,6	128,6	135,1	337	1 126	2 314	1 004	3 540	7 655	103	169	234
	121	159	2	1	133,3	129,2	136,5	187	561	1 121	535	1 627	3 299	193	284	366
	121	159	2	1	133,3	129,2	136,5	187	561	1 121	535	1 627	3 299	193	284	366
	126,5	183,5	2,1	1	139,7	139,7	148,7	1 512	4 905	10 048	4 410	14 777	31 257	309	484	650
	126,5	183,5	2,1	1	139,7	139,7	148,7	989	3 069	6 072	3 060	10 252	21 655	131	219	311
	126,5	183,5	2,1	1	139,7	139,7	148,7	800	2 742	5 723	2 303	8 067	17 220	278	434	577
	126,5	183,5	2,1	1	139,7	139,7	148,7	536	1 733	3 524	1 603	5 476	11 721	114	186	258





Super precision angular contact ball bearings

With large or small balls
Steel or ceramic balls
Steel or Cronidur rings
Open or sealed

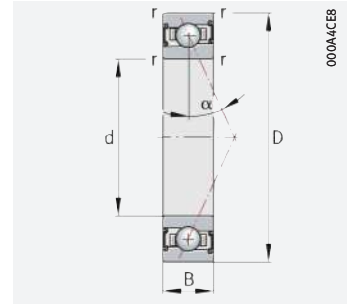
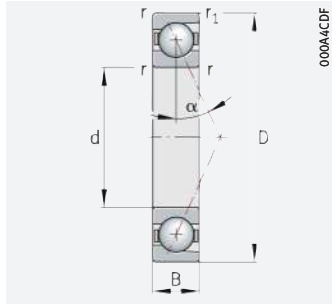

d = 120 – 120 mm

Main dimensions			Basic load ratings		Fatigue limit load C_{ur} N	Limiting speeds ¹⁾		Dimensions		Contact angle α °	Mass m ≈ kg	Designation ²⁾³⁾
d	D	B	dyn. C_r kN	stat. C_{0r} kN		n_G grease min ⁻¹	n_G oil ⁵⁾ min ⁻¹	r	r_1			
120	165	22	72	56	4 850	7 000	11 000	1,1	1,1	25	1,16	B71924-E-T-P4S
	165	22	76	59	5 100	8 000	12 000	1,1	1,1	15	1,16	B71924-C-T-P4S
	165	22	33,5	30	2 600	10 000	15 000	1,1	1,1	25	1,29	HS71924-E-T-P4S
	165	22	72	54	3 450	10 000	15 000	1,1	1,1	25	0,97	HCB71924-E-T-P4S
	165	22	35,5	32	2 750	11 000	17 000	1,1	1,1	15	1,29	HS71924-C-T-P4S
	165	22	76	57	3 600	11 000	17 000	1,1	1,1	15	0,97	HCB71924-C-T-P4S
	165	22	33,5	29	1 830	13 000	20 000	1,1	1,1	25	1,21	HC71924-E-T-P4S
	165	22	51	29	1 830	14 000	22 000	1,1	1,1	25	1,21	XC71924-E-T-P4S
	180	28	109	78	6 500	6 700	10 000	2	2	25	2,07	B7024-E-T-P4S
	180	28	115	82	6 900	7 500	12 000	2	2	15	2,08	B7024-C-T-P4S
	180	28	46,5	38,5	3 200	9 500	14 000	2	2	25	2,32	HS7024-E-T-P4S
	180	28	109	75	4 650	9 500	14 000	2	2	25	1,73	HCB7024-E-T-P4S
	180	28	49,5	40,5	3 400	10 000	16 000	2	2	15	2,33	HS7024-C-T-P4S
	180	28	115	78	4 900	10 000	16 000	2	2	15	1,74	HCB7024-C-T-P4S
	180	28	46,5	36,5	2 280	12 000	19 000	2	2	25	2,2	HC7024-E-T-P4S
	180	28	71	36,5	2 280	13 000	20 000	2	2	25	2,2	XC7024-E-T-P4S
	215	40	196	132	10 500	5 300	8 000	2,1	2,1	25	5,28	B7224-E-T-P4S
	215	40	205	138	11 000	6 000	9 000	2,1	2,1	15	5,3	B7224-C-T-P4S
215	40	196	126	7 400	6 700	9 500	2,1	2,1	25	4,18	HCB7224-E-T-P4S	
215	40	205	132	7 800	7 500	12 000	2,1	2,1	15	4,2	HCB7224-C-T-P4S	

medias ► <https://www.schaeffler.de/std/1D68>

- 1) The limiting speeds are based on elastically preloaded single bearings.
- 2) Explanation of designations ► SP 1.
- 3) The series 719 and 70 are also available with gap seals (type HSS, HCS, XCS or suffix 2RSD).
Ordering examples: B7000-C-2RSD-T-P4S-UL and HSS7000-E-T-P4S-UL.
- 4) L = light preload; M = moderate preload; H = high preload.
- 5) Minimal quantity oil lubrication.

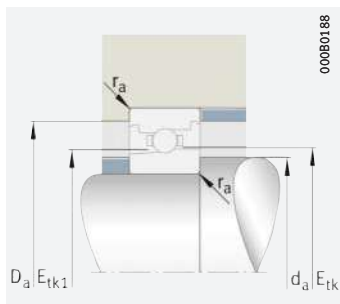

Mounting dimensions

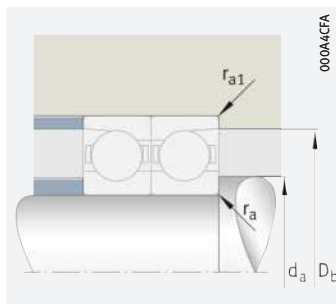

Mounting dimensions

d	Mounting dimensions							Preload force ⁴⁾ F _V			Lift-off force ⁴⁾ K _{aE}			Axial rigidity ⁴⁾ c _a		
	d _a h12	D _a H12	r _a	r _{a1}	E _{tk}	E _{tk1}	E _{tk} E _{tk1}	L	M	H	L	M	H	L	M	H
			max.	max.	min.	min.	max.	N	N	N	N	N	N	N/μm	N/μm	N/μm
120	128	157	0,6	0,6	134	134	138,5	587	2 073	4 361	1 705	6 203	13 450	255	409	553
	128	157	0,6	0,6	134	134	138,5	405	1 321	2 665	1 239	4 349	9 350	109	184	261
	128	157	0,6	0,6	137,3	134	139,2	196	587	1 173	562	1 716	3 492	193	286	371
	128	157	0,6	0,6	134	134	138,5	274	1 101	2 407	785	3 223	7 191	220	362	487
	128	157	0,6	0,6	137,3	134	139,2	122	367	734	363	1 137	2 362	76,8	119	162
	128	157	0,6	0,6	134	134	138,5	208	732	1 530	616	2 286	5 019	93,7	156	218
	128	157	0,6	0,6	137,3	134	139,2	136	407	814	388	1 179	2 389	192	283	364
	128	157	0,6	0,6	137,3	134	139,2	136	407	814	388	1 179	2 389	192	283	364
	131	169	2	1	138,6	138,6	145,1	983	3 298	6 830	2 860	9 902	21 158	290	459	618
	131	169	2	1	138,6	138,6	145,1	653	2 069	4 129	2 008	6 858	14 599	123	206	293
	131	169	2	1	143,3	139,2	146,4	276	828	1 656	795	2 426	4 942	203	302	392
	131	169	2	1	138,6	138,6	145,1	496	1 810	3 849	1 427	5 313	11 543	257	410	547
	131	169	2	1	143,3	139,2	146,4	171	513	1 025	508	1 594	3 313	80,8	126	171
	131	169	2	1	138,6	138,6	145,1	350	1 170	2 406	1 042	3 677	7 953	107	176	245
	131	169	2	1	143,3	139,2	146,4	193	578	1 156	552	1 676	3 398	203	299	385
	131	169	2	1	143,3	139,2	146,4	193	578	1 156	552	1 676	3 398	203	299	385
	140	195	2,1	1	148,4	148,4	159,7	1 989	6 365	12 984	5 797	19 139	40 275	333	518	694
140	195	2,1	1	148,4	148,4	159,7	1 259	3 882	7 683	3 878	12 884	27 179	139	231	326	
140	195	2,1	1	148,4	148,4	159,7	1 055	3 535	7 327	3 037	10 386	21 994	300	465	615	
140	195	2,1	1	148,4	148,4	159,7	688	2 196	4 452	2 051	6 906	14 713	122	197	272	





Super precision angular contact ball bearings

With large or small balls
Steel or ceramic balls
Steel or Cronidur rings
Open or sealed

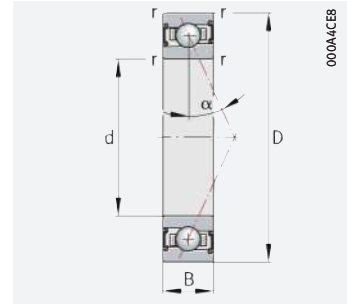
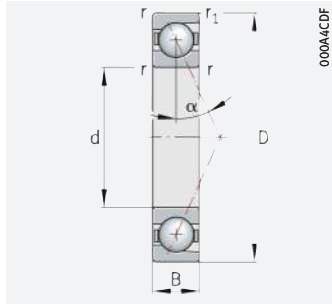

d = 130 – 130 mm

Main dimensions			Basic load ratings		Fatigue limit load C_{ur} N	Limiting speeds ¹⁾		Dimensions		Contact angle α °	Mass m ≈ kg	Designation ²⁾³⁾
d	D	B	dyn. C_r kN	stat. C_{0r} kN		n_G grease min ⁻¹	n_G oil ⁵⁾ min ⁻¹	r	r_1			
130	180	24	85	67	5 500	6 700	10 000	1,5	1,5	25	1,52	B71926-E-T-P4S
	180	24	90	71	5 900	7 000	11 000	1,5	1,5	15	1,52	B71926-C-T-P4S
	180	24	38,5	34,5	2 850	9 000	14 000	1,5	1,5	25	1,71	HS71926-E-T-P4S
	180	24	85	64	3 950	9 000	14 000	1,5	1,5	25	1,34	HCB71926-E-T-P4S
	180	24	40,5	36,5	3 000	10 000	16 000	1,5	1,5	15	1,71	HS71926-C-T-P4S
	180	24	90	68	4 150	10 000	15 000	1,5	1,5	15	1,34	HCB71926-C-T-P4S
	180	24	38,5	33	2 010	12 000	18 000	1,5	1,5	25	1,61	HC71926-E-T-P4S
	180	24	59	33	2 010	13 000	20 000	1,5	1,5	25	1,61	XC71926-E-T-P4S
	200	33	60	48	2 850	11 000	17 000	2	2	25	3,36	HC7026-E-T-P4S
	200	33	92	48	2 850	12 000	19 000	2	2	25	3,36	XC7026-E-T-P4S
	200	33	141	102	8 100	6 000	9 500	2	2	25	3,15	B7026-E-T-P4S
	200	33	149	107	8 600	6 700	10 000	2	2	15	3,16	B7026-C-T-P4S
	200	33	60	50	4 000	8 500	13 000	2	2	25	3,51	HS7026-E-T-P4S
	200	33	141	97	5 800	8 500	13 000	2	2	25	2,61	HCB7026-E-T-P4S
	200	33	64	53	4 250	9 500	15 000	2	2	15	3,52	HS7026-C-T-P4S
	200	33	149	102	6 100	9 500	14 000	2	2	15	2,63	HCB7026-C-T-P4S
	230	40	205	144	11 000	5 000	7 500	3	3	25	6,09	B7226-E-T-P4S
	230	40	215	151	11 600	5 600	8 500	3	3	15	6,11	B7226-C-T-P4S
	230	40	205	138	7 800	6 000	9 000	3	3	25	4,92	HCB7226-E-T-P4S
	230	40	215	144	8 200	7 000	11 000	3	3	15	4,94	HCB7226-C-T-P4S

medias ► <https://www.schaeffler.de/std/1D69>

- 1) The limiting speeds are based on elastically preloaded single bearings.
- 2) Explanation of designations ► SP 1.
- 3) The series 719 and 70 are also available with gap seals (type HSS, HCS, XCS or suffix 2RSD).
Ordering examples: B7000-C-2RSD-T-P4S-UL and HSS7000-E-T-P4S-UL.
- 4) L = light preload; M = moderate preload; H = high preload.
- 5) Minimal quantity oil lubrication.

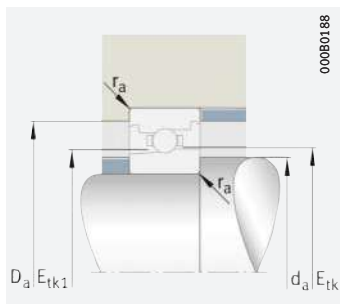

Mounting dimensions

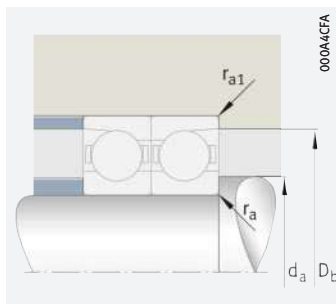

Mounting dimensions

d	Mounting dimensions							Preload force ⁴⁾ F _V			Lift-off force ⁴⁾ K _{aE}			Axial rigidity ⁴⁾ c _a		
	d _a h12	D _a H12	r _a	r _{a1}	E _{tk}	E _{tk1}	E _{tk} E _{tk1}	L	M	H	L	M	H	L	M	H
			max.	max.	min.	min.	max.	N	N	N	N	N	N	N/μm	N/μm	N/μm
130	139	171	0,6	0,6	145,5	145,5	150,7	711	2466	5 161	2 064	7 379	15 916	275	438	590
	139	171	0,6	0,6	145,5	145,5	150,7	486	1 571	3 160	1 488	5 171	11 084	117	197	279
	139	171	0,6	0,6	149,3	145,8	151,4	224	673	1 346	645	1 968	4 004	205	303	393
	139	171	0,6	0,6	145,5	145,5	150,7	346	1 342	2 904	993	3 929	8 680	240	391	524
	139	171	0,6	0,6	149,3	145,8	151,4	139	417	834	413	1 291	2 682	81,1	126	171
	139	171	0,6	0,6	145,5	145,5	150,7	253	875	1 819	750	2 732	5 967	101	167	233
	139	171	0,6	0,6	149,3	145,8	151,4	155	466	932	444	1 349	2 732	204	300	385
	139	171	0,6	0,6	149,3	145,8	151,4	155	466	932	444	1 349	2 732	204	300	385
	142	189	2	1	157,4	152,6	161,2	244	733	1 466	700	2 126	4 308	230	338	435
	142	189	2	1	157,4	152,6	161,2	244	733	1 466	700	2 126	4 308	230	338	435
	142	189	2	1	151,6	151,6	159,3	1 312	4 328	8 915	3 820	13 001	27 627	326	512	689
	142	189	2	1	151,6	151,6	159,3	850	2 669	5 314	2 616	8 846	18 773	137	229	324
	142	189	2	1	157,4	152,6	161,2	357	1 070	2 139	1 026	3 133	6 381	231	344	446
	142	189	2	1	151,6	151,6	159,3	679	2 399	5 054	1 953	7 044	15 161	291	459	611
	142	189	2	1	157,4	152,6	161,2	219	658	1 317	653	2 046	4 251	91,8	143	194
	142	189	2	1	151,6	151,6	159,3	464	1 524	3 119	1 381	4 791	10 306	120	196	272
	148	211,5	2,5	1	160,9	160,9	172	2 065	6 617	13 506	6 015	19 876	41 831	353	549	735
148	211,5	2,5	1	160,9	160,9	172	1 306	4 034	7 993	4 018	13 354	28 189	147	244	344	
148	211,5	2,5	1	160,9	160,9	172	1 098	3 687	7 648	3 160	10 826	22 934	318	493	652	
148	211,5	2,5	1	160,9	160,9	172	716	2 288	4 642	2 132	7 184	15 307	129	208	288	



Super precision angular contact ball bearings

With large or small balls
Steel or ceramic balls
Steel or Cronidur rings
Open or sealed

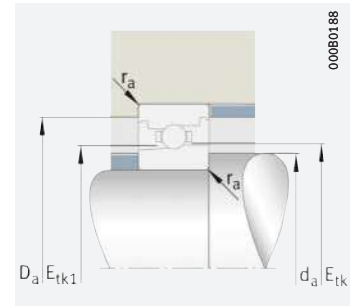
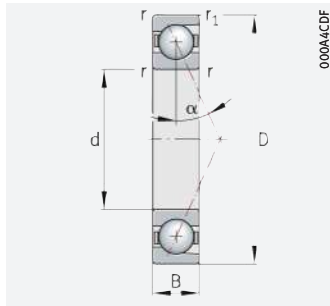

Mounting dimensions

d = 140 – 150 mm

Main dimensions			Basic load ratings		Fatigue limit load C_{ur} N	Limiting speeds ¹⁾		Dimensions		Contact angle α °	Mass m ≈ kg	Designation ²⁾
d	D	B	dyn. C_r kN	stat. C_{0r} kN		n_G grease min^{-1}	n_G oil ⁴⁾ min^{-1}	r	r_1			
140	190	24	89	73	5 900	6 000	9 500	1,5	1,5	25	1,62	B71928-E-T-P4S⁵⁾
	190	24	94	77	6 200	6 700	10 000	1,5	1,5	15	1,62	B71928-C-T-P4S⁵⁾
	190	24	89	70	4 150	8 500	13 000	1,5	1,5	25	1,42	HCB71928-E-T-P4S⁵⁾
	190	24	94	74	4 400	9 500	14 000	1,5	1,5	15	1,42	HCB71928-C-T-P4S⁵⁾
	210	33	145	108	8 400	5 600	9 000	2	2	25	3,34	B7028-E-T-P4S⁵⁾
	210	33	153	114	8 800	6 300	10 000	2	2	15	3,35	B7028-C-T-P4S⁵⁾
	210	33	145	103	5 900	8 000	12 000	2	2	25	2,78	HCB7028-E-T-P4S⁵⁾
	210	33	153	109	6 300	9 000	14 000	2	2	15	2,79	HCB7028-C-T-P4S⁵⁾
	250	42	213	157	11 500	4 500	6 700	3	3	25	7,86	B7228-E-T-P4S
	250	42	224	164	12 100	5 000	7 500	3	3	15	7,88	B7228-C-T-P4S
	250	42	213	150	8 200	5 300	8 000	3	3	25	6,6	HCB7228-E-T-P4S
	250	42	224	157	8 600	6 300	9 500	3	3	15	6,62	HCB7228-C-T-P4S
150	210	28	119	95	7 300	5 600	8 500	2	1	25	2,49	B71930-E-T-P4S
	210	28	125	101	7 700	6 300	9 500	2	1	15	2,49	B71930-C-T-P4S
	210	28	119	91	5 200	7 500	12 000	2	1	25	2,09	HCB71930-E-T-P4S
	210	28	125	96	5 500	8 500	13 000	2	1	15	2,09	HCB71930-C-T-P4S
	225	35	178	130	9 800	5 300	8 000	2,1	2,1	25	4,03	B7030-E-T-P4S
	225	35	187	137	10 300	6 000	9 000	2,1	2,1	15	4,04	B7030-C-T-P4S
	225	35	178	125	6 900	7 500	11 000	2,1	2,1	25	3,24	HCB7030-E-T-P4S
	225	35	187	131	7 300	8 000	13 000	2,1	2,1	15	3,25	HCB7030-C-T-P4S
	270	45	221	169	12 000	4 000	6 000	3	3	25	10,1	B7230-E-T-P4S
	270	45	232	178	12 600	4 500	6 700	3	3	15	10,1	B7230-C-T-P4S
	270	45	221	162	8 500	5 000	7 500	3	3	25	8,79	HCB7230-E-T-P4S
	270	45	232	170	8 900	6 000	8 500	3	3	15	8,82	HCB7230-C-T-P4S

medias ► <https://www.schaeffler.de/std/1D6A>

- 1) The limiting speeds are based on elastically preloaded single bearings.
- 2) Explanation of designations ► SP 1.
- 3) L = light preload; M = moderate preload; H = high preload.
- 4) Minimal quantity oil lubrication.
- 5) The series 719 and 70 are also available with gap seals (type HSS, HCS, XCS or suffix 2RSD).
Ordering examples: B7000-C-2RSD-T-P4S-UL and HSS7000-E-T-P4S-UL.

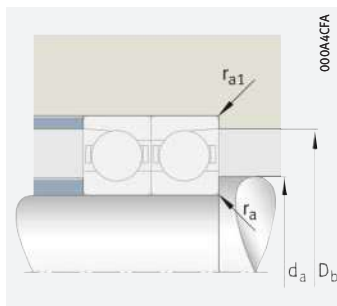

Mounting dimensions

d	Mounting dimensions							Preload force ³⁾ F _V			Lift-off force ³⁾ K _{aE}			Axial rigidity ³⁾ c _a		
	d _a h12	D _a H12	r _a	r _{a1}	E _{tk}	E _{tk1}	E _{tk} E _{tk1}	L	M	H	L	M	H	L	M	H
			max.	max.	min.	min.	max.	N	N	N	N	N	N	N/μm	N/μm	N/μm
140	149	181	0,6	0,6	155,5	155,5	160,6	736	2 564	5 373	2 136	7 663	16 542	292	466	628
	149	181	0,6	0,6	155,5	155,5	160,6	504	1 632	3 289	1 539	5 357	11 496	124	208	295
	149	181	0,6	0,6	155,5	155,5	160,6	348	1 367	2 967	999	3 997	8 852	253	413	554
	149	181	0,6	0,6	155,5	155,5	160,6	259	901	1 876	767	2 806	6 135	107	177	246
	152	199	2	1	161,6	161,6	169,2	1 336	4 416	9 103	3 888	13 252	28 168	339	532	714
	152	199	2	1	161,6	161,6	169,2	866	2 724	5 429	2 661	9 007	19 129	142	237	335
	152	199	2	1	161,6	161,6	169,2	685	2 429	5 123	1 968	7 126	15 352	302	476	633
	152	199	2	1	161,6	161,6	169,2	471	1 553	3 179	1 402	4 871	10 483	125	203	282
	163	226,5	2,5	2,5	175,9	175,9	187	2 141	6 870	14 029	6 233	20 615	43 390	373	579	775
	163	226,5	2,5	2,5	175,9	175,9	187	1 353	4 185	8 302	4 158	13 825	29 200	155	257	362
	163	226,5	2,5	2,5	175,9	175,9	187	1 141	3 839	7 968	3 284	11 267	23 876	336	521	689
	163	226,5	2,5	2,5	175,9	175,9	187	749	2 397	4 864	2 230	7 516	16 017	137	220	304
150	160	199	1	1	168,6	168,6	174,9	1 040	3 522	7 317	3 021	10 536	22 549	331	524	704
	160	199	1	1	168,6	168,6	174,9	706	2 249	4 507	2 161	7 402	15 795	141	235	333
	160	199	1	1	168,6	168,6	174,9	527	1 950	4 164	1 513	5 709	12 445	294	470	627
	160	199	1	1	168,6	168,6	174,9	376	1 268	2 617	1 117	3 963	8 587	123	201	279
	163	213	2,1	1	172,2	172,2	181	1 691	5 520	11 332	4 923	16 566	35 067	371	580	778
	163	213	2,1	1	172,2	172,2	181	1 104	3 443	6 843	3 394	11 397	24 140	156	260	367
	163	213	2,1	1	172,2	172,2	181	889	3 079	6 448	2 556	9 036	19 329	333	522	692
	163	213	2,1	1	172,2	172,2	181	602	1 958	3 992	1 793	6 146	13 171	137	222	308
	178	241,5	2,5	2,5	190,9	190,9	201,9	2 173	6 987	14 280	6 322	20 936	44 075	390	605	808
	178	241,5	2,5	2,5	190,9	190,9	201,9	1 401	4 337	8 611	4 299	14 296	30 211	163	269	380
	178	241,5	2,5	2,5	190,9	190,9	201,9	1 167	3 935	8 175	3 355	11 539	24 467	352	546	722
	178	241,5	2,5	2,5	190,9	190,9	201,9	761	2 440	4 958	2 262	7 633	16 272	143	230	317



Super precision angular contact ball bearings

With large or small balls
Steel or ceramic balls
Steel or Cronidur rings
Open or sealed

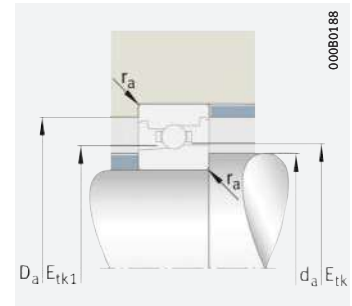
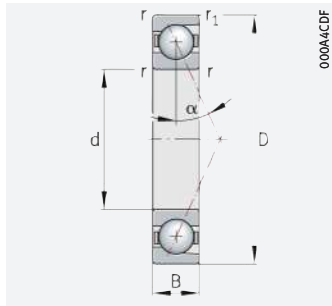

Mounting dimensions

d = 160 – 180 mm

Main dimensions			Basic load ratings		Fatigue limit load C_{ur} N	Limiting speeds ¹⁾		Dimensions		Contact angle α °	Mass m ≈ kg	Designation ²⁾
d	D	B	dyn. C_r kN	stat. C_{0r} kN		n_G grease min ⁻¹	n_G oil ⁴⁾ min ⁻¹	r	r_1			
160	220	28	121	100	7 500	5 300	8 000	2	1	25	2,62	B71932-E-T-P4S
	220	28	128	106	7 900	6 000	9 000	2	1	15	2,63	B71932-C-T-P4S
	220	28	121	96	5 300	7 500	11 000	2	1	25	2,2	HCB71932-E-T-P4S
	220	28	128	101	5 600	8 000	12 000	2	1	15	2,21	HCB71932-C-T-P4S
	240	38	182	138	10 100	5 000	7 500	2,1	2,1	25	5,01	B7032-E-T-P4S
	240	38	192	146	10 600	5 600	8 500	2,1	2,1	15	5,04	B7032-C-T-P4S
	240	38	182	132	7 100	7 000	11 000	2,1	2,1	25	4,18	HCB7032-E-T-P4S
	240	38	192	140	7 500	7 500	12 000	2,1	2,1	15	4,2	HCB7032-C-T-P4S
	290	48	236	192	13 200	3 800	5 600	3	3	25	12,9	B7232-E-T-P4S
	290	48	249	202	13 800	4 300	6 300	3	3	15	12,9	B7232-C-T-P4S
170	230	28	126	108	7 900	5 000	7 500	2	1	25	2,78	B71934-E-T-P4S
	230	28	133	115	8 300	5 600	8 500	2	1	15	2,79	B71934-C-T-P4S
	230	28	126	104	5 600	7 000	11 000	2	1	25	2,32	HCB71934-E-T-P4S
	230	28	133	110	5 900	7 500	12 000	2	1	15	2,33	HCB71934-C-T-P4S
	260	42	229	180	12 600	4 500	7 000	2,1	2,1	25	6,49	B7034-E-T-P4S
	260	42	241	189	13 300	5 300	8 000	2,1	2,1	15	6,52	B7034-C-T-P4S
	310	52	285	241	16 000	3 600	5 300	4	4	25	15,6	B7234-E-T-P4S
	310	52	300	255	16 800	3 800	5 600	4	4	15	15,7	B7234-C-T-P4S
180	250	33	162	138	9 700	4 500	7 000	2	1	25	4,12	B71936-E-T-P4S
	250	33	171	146	10 200	5 300	8 000	2	1	15	4,14	B71936-C-T-P4S
	250	33	162	132	6 900	6 300	10 000	2	1	25	3,43	HCB71936-E-T-P4S
	250	33	171	139	7 200	7 000	11 000	2	1	15	3,45	HCB71936-C-T-P4S
	280	46	236	193	13 100	4 300	6 700	2,1	2,1	25	8,76	B7036-E-T-P4S
	280	46	248	203	13 800	4 800	7 500	2,1	2,1	15	8,79	B7036-C-T-P4S
	320	52	295	260	16 800	3 400	5 000	4	4	25	16,3	B7236-E-T-P4S
	320	52	310	270	17 600	3 800	5 600	4	4	15	16,4	B7236-C-T-P4S

medias ► <https://www.schaeffler.de/std/1D6B>

- The limiting speeds are based on elastically preloaded single bearings.
- Explanation of designations ► □ SP 1.
- L = light preload; M = moderate preload; H = high preload.
- Minimal quantity oil lubrication.

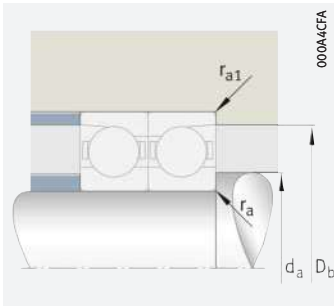

Mounting dimensions

d	Mounting dimensions							Preload force ³⁾ F _V			Lift-off force ³⁾ K _{aE}			Axial rigidity ³⁾ c _a		
	d _a h12	D _a H12	r _a max.	r _{a1} max.	E _{tk} min.	E _{tk1} min.	E _{tk} E _{tk1} max.	L	M	H	L	M	H	L	M	H
								N	N	N	N	N	N	N/μm	N/μm	N/μm
160	170	209	1	1	179,5	179,5	184,7	1 055	3 579	7 439	3 062	10 696	22 899	341	539	725
	170	209	1	1	179,5	179,5	184,7	722	2 304	4 619	2 209	7 572	16 164	145	243	344
	170	209	1	1	179,5	179,5	184,7	521	1 940	4 152	1 495	5 676	12 392	301	481	642
	170	209	1	1	179,5	179,5	184,7	374	1 265	2 614	1 108	3 944	8 551	126	206	285
	174	228	2,1	1	184,7	184,7	193,4	1 715	5 606	11 519	4 988	16 807	35 587	385	601	806
	174	228	2,1	1	184,7	184,7	193,4	1 145	3 574	7 107	3 520	11 821	25 044	163	271	384
	174	228	2,1	1	184,7	184,7	193,4	898	3 121	6 545	2 581	9 154	19 595	345	541	717
	174	228	2,1	1	184,7	184,7	193,4	609	1 986	4 053	1 812	6 221	13 337	142	230	318
	191	259	2,5	2,5	205,9	205,9	216,9	2 326	7 493	15 324	6 760	22 418	47 204	429	665	888
	191	259	2,5	2,5	205,9	205,9	216,9	1 502	4 659	9 263	4 601	15 309	32 375	179	295	416
	191	259	2,5	2,5	205,9	205,9	216,9	1 235	4 183	8 703	3 550	12 254	26 003	387	599	792
	191	259	2,5	2,5	205,9	205,9	216,9	827	2 657	5 402	2 457	8 298	17 692	158	254	350
170	180	219	1	1	188,6	188,6	194,7	1 105	3 757	7 816	3 206	11 221	24 031	364	575	773
	180	219	1	1	188,6	188,6	194,7	742	2 375	4 770	2 266	7 779	16 624	154	256	362
	180	219	1	1	188,6	188,6	194,7	534	2 004	4 295	1 533	5 856	12 804	318	510	681
	180	219	1	1	188,6	188,6	194,7	385	1 306	2 703	1 138	4 063	8 815	133	217	301
	185	246	2,1	1	195,9	195,9	206,9	2 250	7 240	14 802	6 541	21 677	45 639	409	635	848
	185	246	2,1	1	195,9	195,9	206,9	1 448	4 488	8 919	4 439	14 768	31 222	171	282	397
	205	275	3	3	217,1	217,1	230,4	2 860	9 126	18 610	8 307	27 255	57 164	452	699	930
	205	275	3	3	217,1	217,1	230,4	1 864	5 749	11 422	5 698	18 828	39 747	189	311	436
180	192	238	1	1	201,6	201,6	209	1 468	4 890	10 108	4 263	14 618	31 112	402	630	845
	192	238	1	1	201,6	201,6	209	960	3 036	6 076	2 933	9 953	21 191	168	279	394
	192	238	1	1	201,6	201,6	209	731	2 635	5 587	2 098	7 710	16 669	354	561	746
	192	238	1	1	201,6	201,6	209	519	1 726	3 546	1 540	5 380	11 597	148	240	332
	196	264	2,1	1	210,9	210,9	221,9	2 326	7 493	15 324	6 760	22 418	47 204	429	665	888
	196	264	2,1	1	210,9	210,9	221,9	1 502	4 659	9 263	4 601	15 309	32 375	179	295	416
	213,5	286,5	3	3	227,1	227,1	240,4	2 957	9 444	19 266	8 585	28 184	59 117	475	733	976
	213,5	286,5	3	3	227,1	227,1	240,4	1 891	5 843	11 625	5 771	19 076	40 296	197	323	453



Super precision angular contact ball bearings

With large or small balls
Steel or ceramic balls
Steel or Cronidur rings
Open or sealed

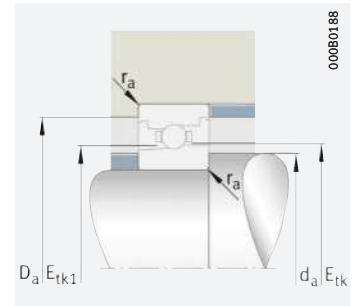
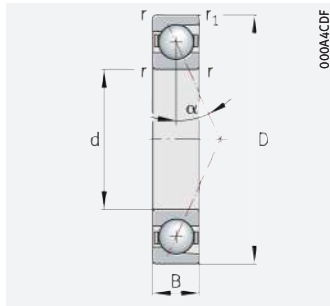

Mounting dimensions

d = 190 – 220 mm

Main dimensions	Basic load ratings		Fatigue limit load	Limiting speeds ¹⁾		Dimensions		Contact angle	Mass	Designation ²⁾		
	dyn. C _r kN	stat. C _{0r} kN		C _{ur} N	n _G grease min ⁻¹	n _G oil ⁴⁾ min ⁻¹	r min.				r ₁ min.	α °
190	260	33	164	144	9 900	4 500	6 700	2	1	25	4,31	B71938-E-T-P4S
	260	33	174	152	10 400	5 000	7 500	2	1	15	4,33	B71938-C-T-P4S
	260	33	164	138	7 000	6 000	9 500	2	1	25	3,58	HCB71938-E-T-P4S
	260	33	174	146	7 400	6 700	10 000	2	1	15	3,6	HCB71938-C-T-P4S
	290	46	243	204	13 600	4 000	6 300	2,1	2,1	25	9,16	B7038-E-T-P4S
	290	46	255	215	14 300	4 500	7 000	2,1	2,1	15	9,2	B7038-C-T-P4S
	340	55	305	275	17 400	3 200	4 800	4	4	25	20	B7238-E-T-P4S
	340	55	320	290	18 300	3 400	5 000	4	4	15	20	B7238-C-T-P4S
200	280	38	199	170	11 300	4 000	6 300	2,1	1,1	25	6,03	B71940-E-T-P4S
	280	38	210	179	11 900	4 500	7 000	2,1	1,1	15	6,05	B71940-C-T-P4S
	280	38	199	162	8 000	5 600	9 000	2,1	1,1	25	5,04	HCB71940-E-T-P4S
	280	38	210	171	8 400	6 300	10 000	2,1	1,1	15	5,07	HCB71940-C-T-P4S
	310	51	295	260	16 700	3 800	6 000	2,1	2,1	25	11,6	B7040-E-T-P4S
	310	51	310	270	17 500	4 300	6 700	2,1	2,1	15	11,6	B7040-C-T-P4S
	360	58	315	295	18 000	3 000	4 500	4	4	25	24,2	B7240-E-T-P4S
	360	58	330	310	19 000	3 200	4 800	4	4	15	24,2	B7240-C-T-P4S
220	300	38	212	192	12 200	3 800	6 000	2,1	1,1	25	6,58	B71944-E-T-P4S
	300	38	224	203	12 900	4 300	6 700	2,1	1,1	15	6,6	B71944-C-T-P4S
	300	38	212	184	8 700	5 300	8 000	2,1	1,1	25	5,47	HCB71944-E-T-P4S
	300	38	224	194	9 200	6 000	9 000	2,1	1,1	15	5,49	HCB71944-C-T-P4S
	340	56	315	295	18 000	3 600	5 300	3	3	25	15,7	B7044-E-T-P4S
	340	56	330	310	19 000	4 000	6 000	3	3	15	15,7	B7044-C-T-P4S
	400	65	385	380	22 100	2 600	4 000	4	4	25	33,1	B7244-E-T-P4S
	400	65	405	400	23 200	2 800	4 300	4	4	15	33,1	B7244-C-T-P4S

medias ► <https://www.schaeffler.de/std/1D6C>

- 1) The limiting speeds are based on elastically preloaded single bearings.
- 2) Explanation of designations ► [SP 1](#).
- 3) L = light preload; M = moderate preload; H = high preload.
- 4) Minimal quantity oil lubrication.

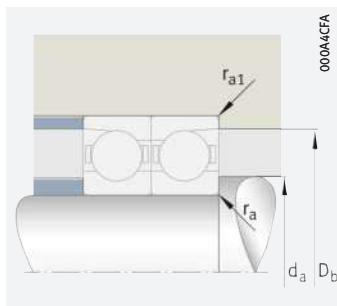

Mounting dimensions

d	Mounting dimensions							Preload force ³⁾ F _V			Lift-off force ³⁾ K _{aE}			Axial rigidity ³⁾ c _a		
	d _a h12	D _a H12	r _a max.	r _{a1} max.	E _{tk} min.	E _{tk1} min.	E _{tk} E _{tk1} max.	L	M	H	L	M	H	L	M	H
								N	N	N	N	N	N	N/μm	N/μm	N/μm
190	202	247	1	1	211,6	211,6	218,9	1 250	4 547	9 653	3 619	13 545	29 595	388	627	847
	202	247	1	1	211,6	211,6	218,9	888	2 947	5 992	2 700	9 612	20 790	166	281	398
	202	247	1	1	211,6	211,6	218,9	557	2 383	5 290	1 596	6 951	15 738	331	554	747
	202	247	1	1	211,6	211,6	218,9	450	1 629	3 436	1 328	5 053	11 178	143	239	334
	206	274	2,1	1	220,9	220,9	231,8	2 128	7 254	15 104	6 172	21 646	46 379	429	678	910
	206	274	2,1	1	220,9	220,9	231,8	1 436	4 599	9 248	4 377	15 038	32 154	181	302	426
	223,5	306,5	3	3	242,1	242,1	255,3	2 797	9 366	19 397	8 105	27 894	59 391	482	755	1 010
	223,5	306,5	3	3	242,1	242,1	255,3	1 846	5 864	11 779	5 614	19 073	40 669	201	333	468
200	214	266	1	1	224,7	224,7	233,1	1 635	5 765	12 127	4 737	17 199	37 246	423	676	911
	214	266	1	1	224,7	224,7	233,1	1 127	3 678	7 439	3 433	12 027	25 875	180	302	427
	214	266	1	1	224,7	224,7	233,1	768	3 083	6 732	2 202	9 005	20 060	366	601	806
	214	266	1	1	224,7	224,7	233,1	571	2 012	4 211	1 688	6 249	13 711	154	256	355
	217	293	2,1	1	232,1	232,1	245,4	2 711	9 065	18 765	7 860	27 018	57 509	460	722	965
	217	293	2,1	1	232,1	232,1	245,4	1 791	5 681	11 402	5 451	18 508	39 448	192	318	448
	238,5	321,5	3	3	257,1	257,1	270,1	2 882	9 666	20 030	8 349	28 771	61 275	503	789	1 055
	238,5	321,5	3	3	257,1	257,1	270,1	1 902	6 047	12 156	5 777	19 638	41 892	210	347	488
220	234	286	1	1	244,7	244,7	253,1	1 705	6 060	12 777	4 937	18 042	39 132	461	739	995
	234	286	1	1	244,7	244,7	253,1	1 185	3 886	7 879	3 600	12 649	27 258	196	329	465
	234	286	1	1	244,7	244,7	253,1	779	3 184	6 985	2 232	9 284	20 766	396	653	877
	234	286	1	1	244,7	244,7	253,1	606	2 147	4 503	1 788	6 651	14 612	169	280	390
	239	321	2,5	1	257,1	257,1	270,1	2 882	9 666	20 030	8 349	28 771	61 275	503	789	1 055
	239	321	2,5	1	257,1	257,1	270,1	1 902	6 047	12 156	5 777	19 638	41 892	210	347	488
	264	356	3	3	282,3	282,3	298,2	3 642	12 021	24 787	10 546	35 720	75 626	540	840	1 119
	264	356	3	3	282,3	282,3	298,2	2 387	7 527	15 105	7 238	24 345	51 776	224	368	515





Super precision angular contact ball bearings

With large or small balls
Steel or ceramic balls
Steel or Cronidur rings
Open or sealed

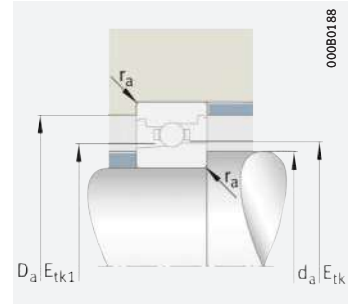
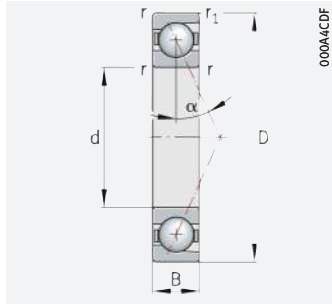

Mounting dimensions

d = 240 – 300 mm

Main dimensions			Basic load ratings		Fatigue limit load C_{ur} N	Limiting speeds ¹⁾		Dimensions		Contact angle α °	Mass m ≈ kg	Designation ²⁾
d	D	B	dyn. C_r kN	stat. C_{Or} kN		n_G grease min^{-1}	n_G oil ⁴⁾ min^{-1}	r	r_1			
								min.	min.			
240	320	38	218	208	12 800	3 600	5 300	2,1	1,1	25	7,08	B71948-E-T-P4S
	320	38	231	220	13 500	4 000	6 000	2,1	1,1	15	7,1	B71948-C-T-P4S
	360	56	320	310	18 500	3 200	5 000	3	3	25	16,7	B7048-E-T-P4S
	360	56	340	330	19 500	3 600	5 600	3	3	15	16,8	B7048-C-T-P4S
260	360	46	295	290	17 100	3 600	5 300	2,1	1,1	15	12	B71952-C-T-P4S
280	380	46	305	320	18 000	3 200	5 000	2,1	1,1	15	12,9	B71956-C-T-P4S
300	420	56	370	405	21 800	3 000	4 500	3	1,1	15	20	B71960-C-T-P4S

medias ► <https://www.schaeffler.de/std/1D6D>

- 1) The limiting speeds are based on elastically preloaded single bearings.
- 2) Explanation of designations ► □ SP 1.
- 3) L = light preload; M = moderate preload; H = high preload.
- 4) Minimal quantity oil lubrication.

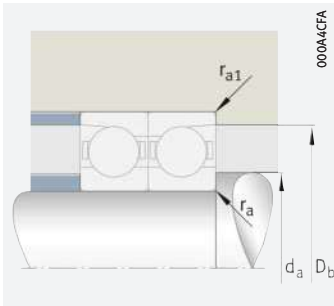

Mounting dimensions

d	Mounting dimensions							Preload force ³⁾ F _V			Lift-off force ³⁾ K _{aE}			Axial rigidity ³⁾ c _a		
	d _a h12	D _a H12	r _a	r _{a1}	E _{tk}	E _{tk1}	E _{tk} E _{tk1}	L	M	H	L	M	H	L	M	H
			max.	max.	min.	min.	max.	N	N	N	N	N	N	N/μm	N/μm	N/μm
240	254	307	1	1	264,7	264,7	272,9	1 760	6 279	13 255	5 092	18 673	40 536	488	781	1 052
	254	307	1	1	264,7	264,7	272,9	1 224	4 024	8 171	3 712	13 066	28 181	207	347	490
	260	341	2,5	1	277,1	277,1	290	2 914	9 801	20 327	8 437	29 140	62 090	521	817	1 092
	260	341	2,5	1	277,1	277,1	290	1 957	6 231	12 533	5 940	20 205	43 114	219	361	507
260	278	342	1	1	290,9	290,9	301,4	1 615	5 221	10 556	4 894	16 900	36 243	222	368	518
280	298	362	1	1	310,9	310,9	321,2	1 696	5 491	11 113	5 134	17 744	38 073	236	392	551
300	322	398	1	1	337,1	337,1	349,7	2 084	6 676	13 480	6 297	21 485	45 930	249	409	574



Super precision angular contact ball bearings

With large or small balls
Ceramic balls
Steel rings
Design DLR

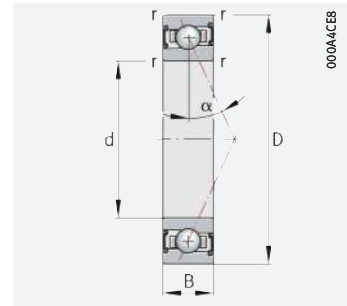
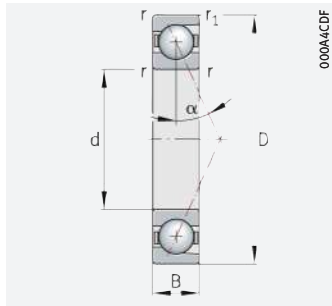

d = 20 – 35 mm

Main dimensions			Basic load ratings		Fatigue limit load C_{ur} N	Limiting speeds ¹⁾		Dimensions		Mass m ≈ kg	Designation ²⁾
d	D	B	dyn. C_r kN	stat. C_{0r} kN		n_G grease min ⁻¹	n_G oil ⁴⁾ min ⁻¹	r	r_1		
20	42	12	9,8	3,9	295	48 000	75 000	0,6	0,6	0,06	HCB7004-EDLR-T-P4S
	42	12	10,3	4,05	310	53 000	80 000	0,6	0,6	0,06	HCB7004-CDLR-T-P4S
	42	12	5,4	2,47	188	60 000	95 000	0,6	0,6	0,072	HC7004-EDLR-T-P4S
	42	12	8,3	2,47	188	67 000	100 000	0,6	0,6	0,072	XC7004-EDLR-T-P4S
25	47	12	13,1	5,4	410	40 000	63 000	0,6	0,6	0,064	HCB7005-EDLR-T-P4S
	47	12	13,7	5,6	430	45 000	70 000	0,6	0,6	0,064	HCB7005-CDLR-T-P4S
	47	12	5,5	2,65	203	53 000	80 000	0,6	0,6	0,083	HC7005-EDLR-T-P4S
	47	12	8,4	2,65	203	56 000	90 000	0,6	0,6	0,083	XC7005-EDLR-T-P4S
30	47	9	8,1	3,95	300	38 000	60 000	0,3	0,3	0,043	HCB71906-EDLR-T-P4S
	47	9	8,5	4,2	320	43 000	67 000	0,3	0,3	0,043	HCB71906-CDLR-T-P4S
	47	9	5,6	2,85	215	48 000	75 000	0,3	0,3	0,044	HC71906-EDLR-T-P4S
	47	9	8,5	2,85	215	53 000	85 000	0,3	0,3	0,044	XC71906-EDLR-T-P4S
	55	13	13,7	6,1	465	34 000	53 000	1	1	0,1	HCB7006-EDLR-T-P4S
	55	13	14,4	6,4	485	38 000	60 000	1	1	0,1	HCB7006-CDLR-T-P4S
	55	13	7,8	3,85	295	43 000	67 000	1	1	0,118	HC7006-EDLR-T-P4S
	55	13	12	3,85	295	48 000	75 000	1	1	0,118	XC7006-EDLR-T-P4S
35	55	10	11,5	6,2	470	32 000	50 000	0,6	0,6	0,065	HCB71907-EDLR-T-P4S
	55	10	12,1	6,5	495	36 000	56 000	0,6	0,6	0,065	HCB71907-CDLR-T-P4S
	55	10	6,1	3,45	260	40 000	63 000	0,6	0,6	0,074	HC71907-EDLR-T-P4S
	55	10	9,3	3,45	260	45 000	70 000	0,6	0,6	0,076	XC71907-EDLR-T-P4S
	62	14	18,4	8,8	670	30 000	45 000	1	1	0,134	HCB7007-EDLR-T-P4S
	62	14	19,3	9,2	700	34 000	53 000	1	1	0,134	HCB7007-CDLR-T-P4S
	62	14	8,4	4,5	345	38 000	60 000	1	1	0,162	HC7007-EDLR-T-P4S
	62	14	12,8	4,5	345	43 000	67 000	1	1	0,162	XC7007-EDLR-T-P4S

medias ► <https://www.schaeffler.de/std/1D6E>

- 1) The limiting speeds are based on elastically preloaded single bearings.
- 2) Explanation of designations ► [SP 1](#).
- 3) L = light preload; M = moderate preload; H = high preload.
- 4) Minimal quantity oil lubrication.

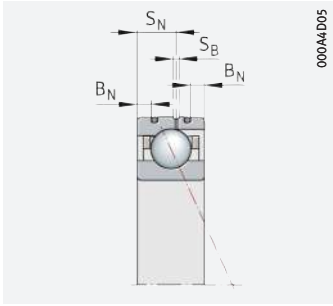

Design DLR

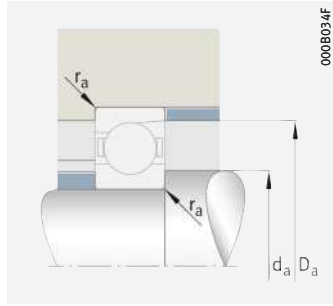

Mounting dimensions

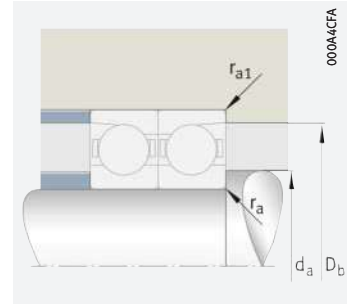

Mounting dimensions

Dimensions	Contact angle			Mounting dimensions				Preload force ³⁾			Lift-off force ³⁾			Axial rigidity ³⁾				
	d	B _N	S _N	S _B	α	d _a h12	D _a H12	r _a max.	r _{a1} max.	L	M	H	L	M	H	L	M	H
				°						N	N	N	N	N	N	N/μm	N/μm	N/μm
20	2,2	6,6	1,4	25	25	37	0,6	0,3	28	140	321	80	410	966	42	74,7	103	
	2,2	6,6	1,4	15	25	37	0,6	0,3	24	94	202	72	297	673	18,7	32,7	46,6	
	2,2	6,6	1,4	25	25	37	0,6	0,3	23	70	140	67	204	415	48,8	72,3	93,7	
	2,2	6,6	1,4	25	25	37	0,6	0,3	23	70	140	67	204	415	48,8	72,3	93,7	
25	2,2	6,6	1,4	25	30	42	0,6	0,3	40	194	443	117	573	1 338	55,4	96,9	133	
	2,2	6,6	1,4	15	30	42	0,6	0,3	35	132	283	104	419	944	24,6	42,5	60,2	
	2,2	6,6	1,4	25	30	42	0,6	0,3	23	70	140	67	204	415	50,4	74,7	96,7	
	2,2	6,6	1,4	25	30	42	0,6	0,3	23	70	140	67	204	415	50,4	74,7	96,7	
30	1,1	5,3	1,4	25	34	43,5	0,3	0,15	22	112	258	60	322	768	52,5	95,1	132	
	1,1	5,3	1,4	15	34	43,5	0,3	0,15	14	68	155	40	210	504	21,1	40	58,3	
	1,1	5,3	1,4	25	34	43,5	0,3	0,15	24	72	143	69	209	425	52,5	77,7	101	
	1,1	5,3	1,4	25	34	43,5	0,3	0,15	24	72	143	69	209	425	52,5	77,7	101	
	2,8	7,2	1,4	25	36	49	1	0,3	42	203	465	117	592	1 395	60,1	107	147	
	2,8	7,2	1,4	15	36	49	1	0,3	35	137	293	104	431	976	26,9	47	67,1	
	2,8	7,2	1,4	25	36	49	1	0,3	33	98	197	94	287	583	60	88,8	115	
	2,8	7,2	1,4	25	36	49	1	0,3	33	98	197	94	287	583	60	88,8	115	
35	1,6	5,8	1,4	25	40	51,5	0,6	0,15	33	158	359	95	463	1 081	66,7	117	161	
	1,6	5,8	1,4	15	40	51,5	0,6	0,15	21	96	213	63	301	709	26,7	49,1	71	
	1,6	5,8	1,4	25	40	51,5	0,6	0,15	26	78	155	74	226	459	60,5	89,4	116	
	1,6	5,8	1,4	25	40	51,5	0,6	0,15	26	78	155	74	226	459	60,5	89,4	116	
	2,8	8	1,4	25	41	56	1	0,3	54	257	585	157	761	1 771	72,1	126	173	
	2,8	8	1,4	15	41	56	1	0,3	46	175	372	138	558	1 255	32	55,5	78,9	
	2,8	8	1,4	25	41	56	1	0,3	35	105	210	101	307	623	67,3	99,5	129	
	2,8	8	1,4	25	41	56	1	0,3	35	105	210	101	307	623	67,3	99,5	129	



Super precision angular contact ball bearings

With large or small balls
Ceramic balls
Steel rings
Design DLR

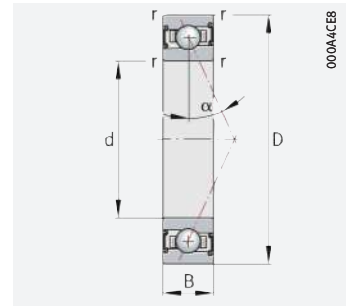
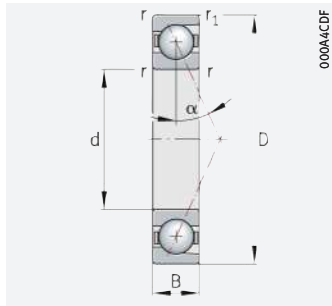

d = 40 – 50 mm

Main dimensions			Basic load ratings		Fatigue limit load C_{ur} N	Limiting speeds ¹⁾		Dimensions		Mass m ≈ kg	Designation ²⁾
d	D	B	dyn. C_r kN	stat. C_{0r} kN		n_G grease min ⁻¹	n_G oil ⁴⁾ min ⁻¹	r	r ₁		
40	62	12	17,1	9	680	28 000	45 000	0,6	0,6	0,086	HCB71908-EDLR-T-P4S
	62	12	18	9,4	720	32 000	50 000	0,6	0,6	0,086	HCB71908-CDLR-T-P4S
	62	12	6,4	3,9	295	36 000	56 000	0,6	0,6	0,119	HC71908-EDLR-T-P4S
	62	12	9,7	3,9	295	40 000	63 000	0,6	0,6	0,119	XC71908-EDLR-T-P4S
	68	15	19,9	10,2	780	28 000	43 000	1	1	0,164	HCB7008-EDLR-T-P4S
	68	15	20,9	10,7	820	30 000	45 000	1	1	0,164	HCB7008-CDLR-T-P4S
	68	15	8,9	5,2	395	34 000	53 000	1	1	0,202	HC7008-EDLR-T-P4S
	68	15	13,7	5,2	395	38 000	60 000	1	1	0,202	XC7008-EDLR-T-P4S
45	68	12	18,2	10,2	770	26 000	40 000	0,6	0,6	0,107	HCB71909-EDLR-T-P4S
	68	12	19,1	10,7	820	28 000	45 000	0,6	0,6	0,107	HCB71909-CDLR-T-P4S
	68	12	9,1	5,4	410	32 000	50 000	0,6	0,6	0,129	HC71909-EDLR-T-P4S
	68	12	13,9	5,4	410	36 000	56 000	0,6	0,6	0,129	XC71909-EDLR-T-P4S
	75	16	26,5	13,6	1030	24 000	38 000	1	1	0,191	HCB7009-EDLR-T-P4S
	75	16	28	14,3	1090	26 000	40 000	1	1	0,191	HCB7009-CDLR-T-P4S
	75	16	11,6	6,8	520	30 000	48 000	1	1	0,248	HC7009-EDLR-T-P4S
	75	16	17,8	6,8	520	34 000	53 000	1	1	0,248	XC7009-EDLR-T-P4S
50	72	12	18,6	10,8	820	24 000	36 000	0,6	0,6	0,102	HCB71910-EDLR-T-P4S
	72	12	19,6	11,4	870	26 000	40 000	0,6	0,6	0,102	HCB71910-CDLR-T-P4S
	72	12	9,4	5,8	445	30 000	48 000	0,6	0,6	0,13	HC71910-EDLR-T-P4S
	72	12	14,3	5,8	445	34 000	53 000	0,6	0,6	0,13	XC71910-EDLR-T-P4S
	80	16	27,5	14,7	1120	22 000	34 000	1	1	0,206	HCB7010-EDLR-T-P4S
	80	16	29	15,4	1170	24 000	38 000	1	1	0,205	HCB7010-CDLR-T-P4S
	80	16	12,1	7,4	560	28 000	43 000	1	1	0,262	HC7010-EDLR-T-P4S
	80	16	18,4	7,4	560	32 000	48 000	1	1	0,262	XC7010-EDLR-T-P4S

medias ► <https://www.schaeffler.de/std/1D6F>

- 1) The limiting speeds are based on elastically preloaded single bearings.
- 2) Explanation of designations ► [SP 1](#).
- 3) L = light preload; M = moderate preload; H = high preload.
- 4) Minimal quantity oil lubrication.

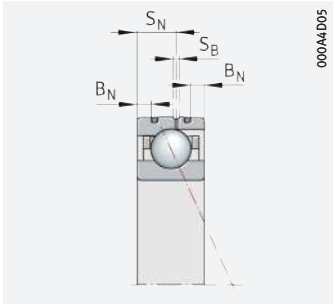

Design DLR

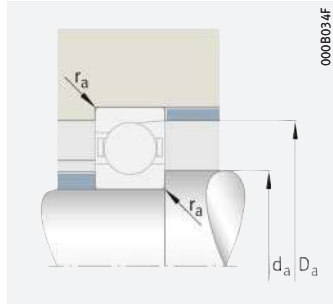

Mounting dimensions

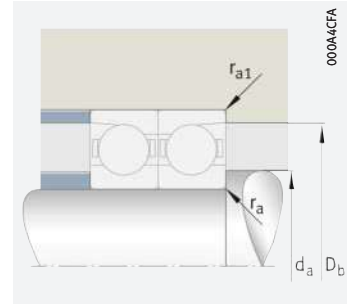

Mounting dimensions

Dimensions	Contact angle			Mounting dimensions				Preload force ³⁾			Lift-off force ³⁾			Axial rigidity ³⁾				
	d	B _N	S _N	S _B	α	d _a h12	D _a H12	r _a max.	r _{a1} max.	L	M	H	L	M	H	L	M	H
				°						N	N	N	N	N	N	N/μm	N/μm	N/μm
40	2,2	6,6	1,4	25	45	58,5	0,6	0,15	41	220	514	117	645	1 548	72,4	132	183	
	2,2	6,6	1,4	15	45	58,5	0,6	0,15	39	156	337	116	494	1 127	33,5	59,2	84,7	
	2,2	6,6	1,4	25	45	58,5	0,6	0,15	27	82	164	78	238	484	66,4	98	127	
	2,2	6,6	1,4	25	45	58,5	0,6	0,15	27	82	164	78	238	484	66,4	98	127	
	2,8	8,5	1,4	25	46	62	1	0,3	55	271	622	159	797	1 875	80	142	195	
	2,8	8,5	1,4	15	46	62	1	0,3	49	188	402	146	597	1 350	36,1	63,1	89,9	
	2,8	8,5	1,4	25	46	62	1	0,3	37	110	221	106	321	652	74,2	110	142	
	2,8	8,5	1,4	25	46	62	1	0,3	37	110	221	106	321	652	74,2	110	142	
45	2,2	6,6	1,4	25	50	63,5	0,6	0,15	42	233	547	121	682	1 643	78,5	144	200	
	2,2	6,6	1,4	15	50	63,5	0,6	0,15	40	164	355	120	516	1 182	36,2	64,1	91,7	
	2,2	6,6	1,4	25	50	63,5	0,6	0,15	38	113	226	108	329	667	76,6	113	146	
	2,2	6,6	1,4	25	50	63,5	0,6	0,15	38	113	226	108	329	667	76,6	113	146	
	3,4	9,3	1,4	25	51	69	1	0,3	89	389	869	254	1 145	2 622	95,8	163	223	
	3,4	9,3	1,4	15	51	69	1	0,3	71	261	549	212	827	1 843	41,9	71,9	102	
	3,4	9,3	1,4	25	51	69	1	0,3	48	143	286	137	417	848	84,4	125	161	
	3,4	9,3	1,4	25	51	69	1	0,3	48	143	286	137	417	848	84,4	125	161	
50	2,2	6,6	1,4	25	55	67,5	0,6	0,15	40	229	542	115	671	1 626	79,7	148	205	
	2,2	6,6	1,4	15	55	67,5	0,6	0,15	41	167	362	121	525	1 205	37,5	66,4	95	
	2,2	6,6	1,4	25	55	67,5	0,6	0,15	39	116	231	110	336	682	80,9	119	154	
	2,2	6,6	1,4	25	55	67,5	0,6	0,15	39	116	231	110	336	682	80,9	119	154	
	3,4	9,3	1,4	25	56	74	1	0,3	90	400	895	259	1 175	2 697	100	171	234	
	3,4	9,3	1,4	15	56	74	1	0,3	73	268	566	217	848	1 894	43,9	75,3	107	
	3,4	9,3	1,4	25	56	74	1	0,3	50	149	298	143	435	883	90	133	172	
	3,4	9,3	1,4	25	56	74	1	0,3	50	149	298	143	435	883	90	133	172	



Super precision angular contact ball bearings

With large or small balls
Ceramic balls
Steel rings
Design DLR

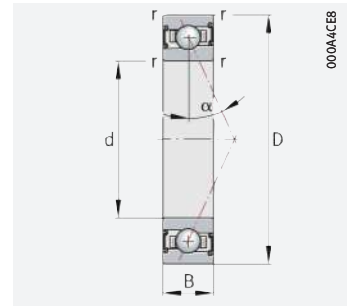
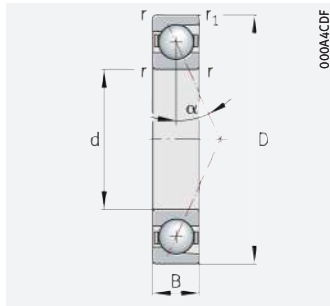

d = 55 – 65 mm

Main dimensions			Basic load ratings		Fatigue limit load	Limiting speeds ¹⁾		Dimensions		Mass	Designation ²⁾
d	D	B	dyn. C _r kN	stat. C _{0r} kN	C _{ur} N	n _G grease min ⁻¹	n _G oil ⁴⁾ min ⁻¹	r	r ₁	m ≈ kg	
55	80	13	22,2	13,1	1 000	22 000	32 000	1	1	0,14	HCB71911-EDLR-T-P4S
	80	13	23,5	13,8	1 050	24 000	36 000	1	1	0,14	HCB71911-CDLR-T-P4S
	80	13	12,3	7,7	590	28 000	43 000	1	1	0,166	HC71911-EDLR-T-P4S
	80	13	18,8	7,7	590	30 000	48 000	1	1	0,166	XC71911-EDLR-T-P4S
	90	18	37	20,1	1 530	20 000	30 000	1,1	1,1	0,302	HCB7011-EDLR-T-P4S
	90	18	38,5	21,2	1 610	22 000	34 000	1,1	1,1	0,302	HCB7011-CDLR-T-P4S
	90	18	16,9	10,4	790	26 000	40 000	1,1	1,1	0,378	HC7011-EDLR-T-P4S
	90	18	26	10,4	790	28 000	43 000	1,1	1,1	0,378	XC7011-EDLR-T-P4S
60	85	13	23,4	14,5	1 100	20 000	30 000	1	1	0,151 [^]	HCB71912-EDLR-T-P4S
	85	13	24,7	15,3	1 170	22 000	34 000	1	1	0,151	HCB71912-CDLR-T-P4S
	85	13	12,6	8,3	630	26 000	40 000	1	1	0,18	HC71912-EDLR-T-P4S
	85	13	19,4	8,3	630	28 000	43 000	1	1	0,179	XC71912-EDLR-T-P4S
	95	18	38	21,6	1 650	19 000	28 000	1,1	1,1	0,326	HCB7012-EDLR-T-P4S
	95	18	40	22,7	1 730	20 000	32 000	1,1	1,1	0,326	HCB7012-CDLR-T-P4S
	95	18	17,6	11,3	860	24 000	36 000	1,1	1,1	0,404	HC7012-EDLR-T-P4S
	95	18	27	11,3	860	26 000	40 000	1,1	1,1	0,404	XC7012-EDLR-T-P4S
65	90	13	23,7	15,3	1 160	19 000	28 000	1	1	0,161	HCB71913-EDLR-T-P4S
	90	13	25	16,1	1 230	20 000	32 000	1	1	0,161	HCB71913-CDLR-T-P4S
	90	13	13	8,9	680	24 000	36 000	1	1	0,19	HC71913-EDLR-T-P4S
	90	13	19,9	8,9	680	26 000	40 000	1	1	0,19	XC71913-EDLR-T-P4S
	100	18	39	23,1	1 760	17 000	26 000	1,1	1,1	0,344	HCB7013-EDLR-T-P4S
	100	18	41,5	24,3	1 850	19 000	30 000	1,1	1,1	0,343	HCB7013-CDLR-T-P4S
	100	18	18,2	12,2	930	22 000	34 000	1,1	1,1	0,427	HC7013-EDLR-T-P4S
	100	18	28	12,2	930	24 000	38 000	1,1	1,1	0,427	XC7013-EDLR-T-P4S

medias ► <https://www.schaeffler.de/std/1D70>

- 1) The limiting speeds are based on elastically preloaded single bearings.
- 2) Explanation of designations ► [SP 1](#).
- 3) L = light preload; M = moderate preload; H = high preload.
- 4) Minimal quantity oil lubrication.

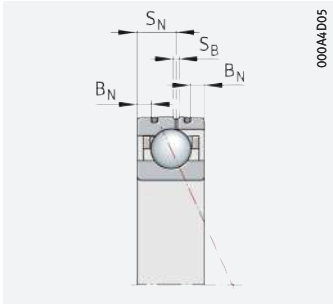

Design DLR

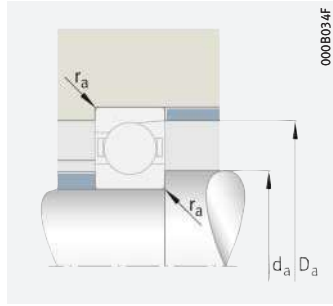

Mounting dimensions

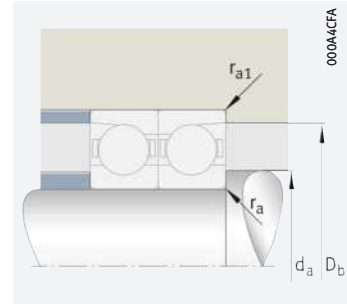

Mounting dimensions

Dimensions	Contact angle			Mounting dimensions				Preload force ³⁾			Lift-off force ³⁾			Axial rigidity ³⁾				
	d	B _N	S _N	S _B	α	d _a h12	D _a H12	r _a max.	r _{a1} max.	L	M	H	L	M	H	L	M	H
				°						N	N	N	N	N	N	N/μm	N/μm	N/μm
55	2,8	7,2	1,4	25	60	75,5	0,6	0,3	57	296	686	164	867	2058	93	167	230	
	2,8	7,2	1,4	15	60	75,5	0,6	0,3	53	208	447	157	654	1487	42,4	74,1	106	
	2,8	7,2	1,4	25	60	75,5	0,6	0,3	51	152	304	145	442	897	92,7	137	177	
	2,8	7,2	1,4	25	60	75,5	0,6	0,3	51	152	304	145	442	897	92,7	137	177	
	4,3	9,7	1,4	25	62	83	1	0,6	136	562	1236	390	1653	3728	121	203	275	
	4,3	9,7	1,4	15	62	83	1	0,6	102	366	765	305	1158	2559	51,9	87,9	124	
	4,3	9,7	1,4	25	62	83	1	0,6	70	210	421	201	613	1244	105	155	201	
	4,3	9,7	1,4	25	62	83	1	0,6	70	210	421	201	613	1244	105	155	201	
60	2,8	7,2	1,4	25	65	80,5	0,6	0,3	57	303	707	163	887	2118	98,5	179	246	
	2,8	7,2	1,4	15	65	80,5	0,6	0,3	54	214	462	159	671	1530	45,1	79	112	
	2,8	7,2	1,4	25	65	80,5	0,6	0,3	52	155	311	148	452	917	97,7	144	186	
	2,8	7,2	1,4	25	65	80,5	0,6	0,3	52	155	311	148	452	917	97,7	144	186	
	4,3	9,7	1,4	25	67	88	1	0,6	136	569	1256	391	1673	3782	126	211	286	
	4,3	9,7	1,4	15	67	88	1	0,6	106	379	794	315	1198	2651	54,4	92,2	130	
	4,3	9,7	1,4	25	67	88	1	0,6	73	219	438	209	638	1294	112	165	213	
	4,3	9,7	1,4	25	67	88	1	0,6	73	219	438	209	638	1294	112	165	213	
65	2,8	7,2	1,4	25	70	85,5	0,6	0,3	58	309	723	165	904	2165	102	185	255	
	2,8	7,2	1,4	15	70	85,5	0,6	0,3	55	219	473	161	684	1562	46,6	81,7	116	
	2,8	7,2	1,4	25	70	85,5	0,6	0,3	53	160	321	153	466	946	103	152	196	
	2,8	7,2	1,4	25	70	85,5	0,6	0,3	53	160	321	153	466	946	103	152	196	
	4	10,4	1,4	25	72	93	1	0,6	137	577	1276	392	1694	3836	131	219	297	
	4	10,4	1,4	15	72	93	1	0,6	107	385	808	318	1213	2688	56,4	95,6	135	
	4	10,4	1,4	25	72	93	1	0,6	74	223	445	213	647	1313	118	173	224	
	4	10,4	1,4	25	72	93	1	0,6	74	223	445	213	647	1313	118	173	224	



Super precision angular contact ball bearings

With large or small balls
Ceramic balls
Steel rings
Design DLR

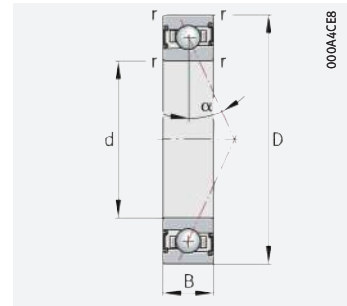
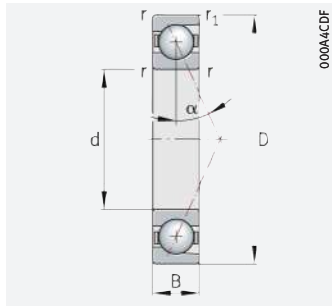

d = 70 – 80 mm

Main dimensions			Basic load ratings		Fatigue limit load	Limiting speeds ¹⁾		Dimensions		Mass	Designation ²⁾
d	D	B	dyn. C _r kN	stat. C _{0r} kN	C _{ur} N	n _G grease min ⁻¹	n _G oil ⁴⁾ min ⁻¹	r	r ₁	m ≈ kg	
70	100	16	32,5	20,8	1 580	17 000	26 000	1	1	0,268	HCB71914-EDLR-T-P4S
	100	16	34,5	22	1 670	19 000	28 000	1	1	0,268	HCB71914-CDLR-T-P4S
	100	16	16,8	11,7	890	22 000	34 000	1	1	0,322	HC71914-EDLR-T-P4S
	100	16	25,5	11,7	890	24 000	36 000	1	1	0,322	XC71914-EDLR-T-P4S
	110	20	48	28	2 120	16 000	24 000	1,1	1,1	0,48	HCB7014-EDLR-T-P4S
	110	20	50	29,5	2 230	18 000	28 000	1,1	1,1	0,48	HCB7014-CDLR-T-P4S
	110	20	23,6	15,6	1 190	20 000	32 000	1,1	1,1	0,596	HC7014-EDLR-T-P4S
	110	20	36	15,6	1 190	22 000	34 000	1,1	1,1	0,596	XC7014-EDLR-T-P4S
75	105	16	33	21,9	1 670	16 000	24 000	1	1	0,277	HCB71915-EDLR-T-P4S
	105	16	35	23,1	1 760	18 000	28 000	1	1	0,277	HCB71915-CDLR-T-P4S
	105	16	17,2	12,5	950	20 000	32 000	1	1	0,345	HC71915-EDLR-T-P4S
	105	16	26,5	12,5	950	22 000	34 000	1	1	0,345	XC71915-EDLR-T-P4S
	115	20	49,5	29,5	2 260	15 000	24 000	1,1	1,1	0,5	HCB7015-EDLR-T-P4S
	115	20	52	31,5	2 380	17 000	26 000	1,1	1,1	0,5	HCB7015-CDLR-T-P4S
	115	20	23,9	16,2	1 240	19 000	30 000	1,1	1,1	0,624	HC7015-EDLR-T-P4S
	115	20	36,5	16,2	1 240	22 000	32 000	1,1	1,1	0,624	XC7015-EDLR-T-P4S
80	110	16	33,5	23	1 750	15 000	24 000	1	1	0,295	HCB71916-EDLR-T-P4S
	110	16	35,5	24,3	1 850	17 000	26 000	1	1	0,295	HCB71916-CDLR-T-P4S
	110	16	19,2	14	1 060	19 000	30 000	1	1	0,342	HC71916-EDLR-T-P4S
	110	16	29,5	14	1 060	22 000	32 000	1	1	0,342	XC71916-EDLR-T-P4S
	125	22	61	37,5	2 800	14 000	22 000	1,1	1,1	0,69	HCB7016-EDLR-T-P4S
	125	22	64	39	2 950	15 000	24 000	1,1	1,1	0,69	HCB7016-CDLR-T-P4S
	125	22	28,5	19,7	1 480	18 000	28 000	1,1	1,1	0,86	HC7016-EDLR-T-P4S
	125	22	44	19,7	1 480	20 000	30 000	1,1	1,1	0,86	XC7016-EDLR-T-P4S

medias ► <https://www.schaeffler.de/std/1D71>

- 1) The limiting speeds are based on elastically preloaded single bearings.
- 2) Explanation of designations ► [SP 1](#).
- 3) L = light preload; M = moderate preload; H = high preload.
- 4) Minimal quantity oil lubrication.

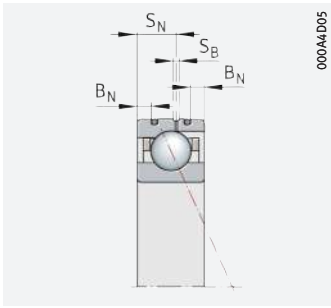

Design DLR

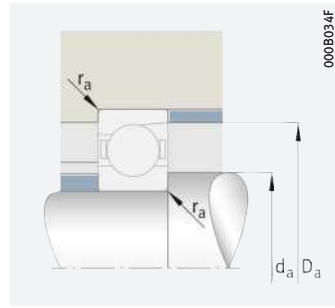

Mounting dimensions

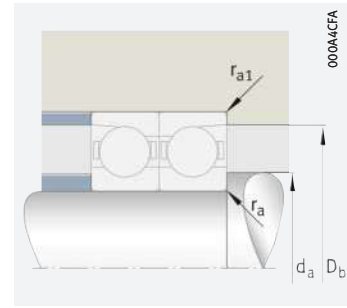

Mounting dimensions

Dimensions	Contact angle			Mounting dimensions				Preload force ³⁾			Lift-off force ³⁾			Axial rigidity ³⁾				
	d	B _N	S _N	S _B	α	d _a h12	D _a H12	r _a max.	r _{a1} max.	L	M	H	L	M	H	L	M	H
				°						N	N	N	N	N	N	N/μm	N/μm	N/μm
70	3,1	9,3	1,4	25	76	94,5	0,6	0,3	98	459	1040	281	1343	3118	126	218	298	
	3,1	9,3	1,4	15	76	94,5	0,6	0,3	83	312	665	245	980	2200	55,5	95,3	135	
	3,1	9,3	1,4	25	76	94,5	0,6	0,3	69	207	414	198	602	1221	117	173	223	
	3,1	9,3	1,4	25	76	94,5	0,6	0,3	69	207	414	198	602	1221	117	173	223	
	4	11,6	1,4	25	77	102	1	0,6	188	749	1633	540	2203	4915	147	242	326	
	4	11,6	1,4	15	77	102	1	0,6	139	487	1014	414	1538	3380	62,3	105	147	
	4	11,6	1,4	25	77	102	1	0,6	98	293	587	280	853	1731	130	192	248	
	4	11,6	1,4	25	77	102	1	0,6	98	293	587	280	853	1731	130	192	248	
75	3,1	9,3	1,4	25	81	99,5	0,6	0,3	95	454	1034	273	1328	3094	128	223	305	
	3,1	9,3	1,4	15	81	99,5	0,6	0,3	83	317	676	247	991	2229	57,1	98,2	139	
	3,1	9,3	1,4	25	81	99,5	0,6	0,3	70	210	421	201	611	1240	123	181	233	
	3,1	9,3	1,4	25	81	99,5	0,6	0,3	70	210	421	201	611	1240	123	181	233	
	4	11,6	1,4	25	82	107	1	0,6	192	769	1679	551	2260	5050	153	253	341	
	4	11,6	1,4	15	82	107	1	0,6	145	508	1059	431	1603	3524	65,4	110	154	
	4	11,6	1,4	25	82	107	1	0,6	99	298	597	285	868	1761	134	197	255	
	4	11,6	1,4	25	82	107	1	0,6	99	298	597	285	868	1761	134	197	255	
80	3,1	9,3	1,4	25	86	104	0,6	0,3	95	459	1049	273	1344	3137	132	230	315	
	3,1	9,3	1,4	15	86	104	0,6	0,3	84	321	686	249	1004	2259	58,8	101	143	
	3,1	9,3	1,4	25	86	104	0,6	0,3	79	236	473	226	686	1392	130	192	248	
	3,1	9,3	1,4	25	86	104	0,6	0,3	79	236	473	226	686	1392	130	192	248	
	4,7	12,2	2,2	25	88	117	1	0,6	252	977	2113	726	2872	6354	175	284	383	
	4,7	12,2	2,2	15	88	117	1	0,6	186	640	1327	554	2020	4415	74	123	173	
	4,7	12,2	2,2	25	88	117	1	0,6	117	352	704	336	1023	2075	146	215	278	
	4,7	12,2	2,2	25	88	117	1	0,6	117	352	704	336	1023	2075	146	215	278	



Super precision angular contact ball bearings

With large or small balls
Ceramic balls
Steel rings
Design DLR

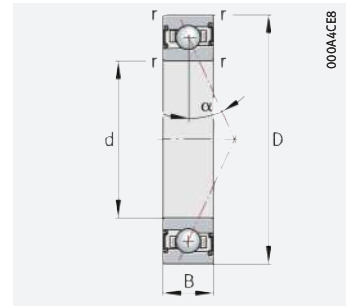
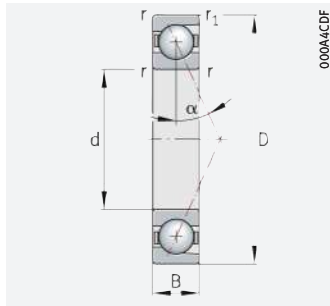

d = 85 – 95 mm

Main dimensions			Basic load ratings		Fatigue limit load	Limiting speeds ¹⁾		Dimensions		Mass	Designation ²⁾
d	D	B	dyn. C _r kN	stat. C _{0r} kN	C _{ur} N	n _G grease min ⁻¹	n _G oil ⁴⁾ min ⁻¹	r	r ₁	m ≈ kg	
85	120	18	44,5	30	2 270	14 000	22 000	1,1	1,1	0,43	HCB71917-EDLR-T-P4S
	120	18	47	32	2 400	15 000	24 000	1,1	1,1	0,43	HCB71917-CDLR-T-P4S
	120	18	20	15,3	1 150	18 000	28 000	1,1	1,1	0,535	HC71917-EDLR-T-P4S
	120	18	30,5	15,3	1 150	20 000	30 000	1,1	1,1	0,535	XC71917-EDLR-T-P4S
	130	22	63	39,5	2 900	13 000	20 000	1,1	1,1	0,72	HCB7017-EDLR-T-P4S
	130	22	66	41,5	3 050	15 000	22 000	1,1	1,1	0,72	HCB7017-CDLR-T-P4S
	130	22	29	20,5	1 510	17 000	26 000	1,1	1,1	0,893	HC7017-EDLR-T-P4S
	130	22	44,5	20,5	1 510	19 000	30 000	1,1	1,1	0,893	XC7017-EDLR-T-P4S
90	125	18	45	31,5	2 330	13 000	20 000	1,1	1,1	0,445	HCB71918-EDLR-T-P4S
	125	18	48	33,5	2 460	15 000	22 000	1,1	1,1	0,445	HCB71918-CDLR-T-P4S
	125	18	21,9	16,9	1 240	17 000	26 000	1,1	1,1	0,55	HC71918-EDLR-T-P4S
	125	18	33,5	16,9	1 240	19 000	30 000	1,1	1,1	0,55	XC71918-EDLR-T-P4S
	140	24	74	46,5	3 300	12 000	19 000	1,5	1,5	0,93	HCB7018-EDLR-T-P4S
	140	24	78	49	3 450	14 000	22 000	1,5	1,5	0,93	HCB7018-CDLR-T-P4S
	140	24	34	24	1 710	16 000	24 000	1,5	1,5	1,17	HC7018-EDLR-T-P4S
	140	24	52	24	1 710	18 000	28 000	1,5	1,5	1,17	XC7018-EDLR-T-P4S
95	130	18	46	33	2 380	13 000	19 000	1,1	1,1	0,463	HCB71919-EDLR-T-P4S
	130	18	48,5	35	2 500	14 000	22 000	1,1	1,1	0,462	HCB71919-CDLR-T-P4S
	130	18	22,5	17,9	1 290	16 000	24 000	1,1	1,1	0,57	HC71919-EDLR-T-P4S
	130	18	34,5	17,9	1 290	18 000	28 000	1,1	1,1	0,57	XC71919-EDLR-T-P4S
	145	24	77	49,5	3 450	12 000	18 000	1,5	1,5	0,98	HCB7019-EDLR-T-P4S
	145	24	81	52	3 600	13 000	20 000	1,5	1,5	0,98	HCB7019-CDLR-T-P4S
	145	24	34	25	1 730	15 000	24 000	1,5	1,5	1,22	HC7019-EDLR-T-P4S
	145	24	52	25	1 730	17 000	26 000	1,5	1,5	1,22	XC7019-EDLR-T-P4S

medias ► <https://www.schaeffler.de/std/1D72>

- 1) The limiting speeds are based on elastically preloaded single bearings.
- 2) Explanation of designations ► □ SP 1.
- 3) L = light preload; M = moderate preload; H = high preload.
- 4) Minimal quantity oil lubrication.

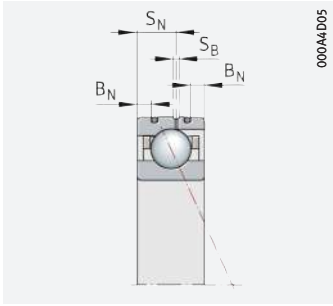

Design DLR

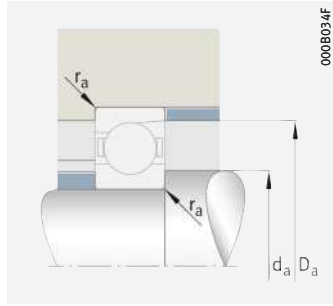

Mounting dimensions

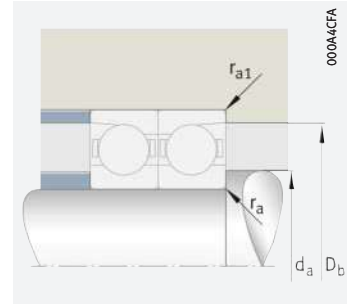

Mounting dimensions

Dimensions	Contact angle			Mounting dimensions				Preload force ³⁾ F _V			Lift-off force ³⁾ K _{aE}			Axial rigidity ³⁾ c _a				
	d	B _N	S _N	S _B	α	d _a h12	D _a H12	r _a max.	r _{a1} max.	L	M	H	L	M	H	L	M	H
				°						N	N	N	N	N	N	N/μm	N/μm	N/μm
85	4	10,4	2,2	25	92	114	0,6	0,6	143	627	1 403	409	1 837	4 197	154	262	356	
	4	10,4	2,2	15	92	114	0,6	0,6	117	428	906	346	1 341	2 985	67,4	114	161	
	4	10,4	2,2	25	92	114	0,6	0,6	82	247	493	236	716	1 452	140	206	265	
	4	10,4	2,2	25	92	114	0,6	0,6	82	247	493	236	716	1 452	140	206	265	
	4,7	12,2	2,2	25	93	122	1	0,6	256	997	2 159	736	2 927	6 484	181	296	398	
	4,7	12,2	2,2	15	93	122	1	0,6	189	653	1 356	562	2 058	4 501	76,9	128	179	
	4,7	12,2	2,2	25	93	122	1	0,6	120	359	718	343	1 042	2 115	150	221	286	
	4,7	12,2	2,2	25	93	122	1	0,6	120	359	718	343	1 042	2 115	150	221	286	
90	4	10,4	2,2	25	97	119	0,6	0,6	147	648	1 450	421	1 897	4 337	160	272	369	
	4	10,4	2,2	15	97	119	0,6	0,6	118	434	919	349	1 357	3 023	69,4	118	165	
	4	10,4	2,2	25	97	119	0,6	0,6	90	269	538	257	781	1 584	144	212	273	
	4	10,4	2,2	25	97	119	0,6	0,6	90	269	538	257	781	1 584	144	212	273	
	5,5	14,5	2,2	25	100	131	1,5	0,6	319	1 201	2 577	916	3 528	7 745	195	316	423	
	5,5	14,5	2,2	15	100	131	1,5	0,6	230	781	1 613	685	2 464	5 361	82,3	136	191	
	5,5	14,5	2,2	25	100	131	1,5	0,6	141	423	845	404	1 228	2 490	163	241	310	
	5,5	14,5	2,2	25	100	131	1,5	0,6	141	423	845	404	1 228	2 490	163	241	310	
95	4	10,4	2,2	25	102	124	0,6	0,6	148	656	1 470	423	1 918	4 393	164	280	380	
	4	10,4	2,2	15	102	124	0,6	0,6	119	440	932	352	1 373	3 061	71,3	121	170	
	4	10,4	2,2	25	102	124	0,6	0,6	92	276	552	263	801	1 623	150	221	285	
	4	10,4	2,2	25	102	124	0,6	0,6	92	276	552	263	801	1 623	150	221	285	
	5,5	14,5	2,2	25	105	136	1,5	0,6	322	1 220	2 622	924	3 581	7 871	203	328	439	
	5,5	14,5	2,2	15	105	136	1,5	0,6	233	794	1 643	693	2 499	5 442	85,3	141	197	
	5,5	14,5	2,2	25	105	136	1,5	0,6	141	423	845	404	1 227	2 488	167	246	317	
	5,5	14,5	2,2	25	105	136	1,5	0,6	141	423	845	404	1 227	2 488	167	246	317	



Super precision angular contact ball bearings

With large or small balls
Ceramic balls
Steel rings
Design DLR

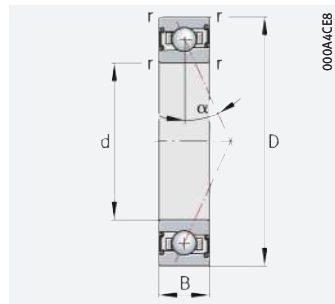
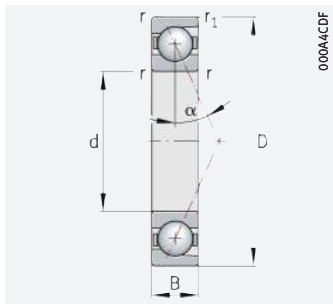

d = 100 – 110 mm

Main dimensions			Basic load ratings		Fatigue limit load C_{ur} N	Limiting speeds ¹⁾		Dimensions		Mass m ≈ kg	Designation ²⁾
d	D	B	dyn. C_r kN	stat. C_{0r} kN		n_G grease min ⁻¹	n_G oil ⁴⁾ min ⁻¹	r	r_1		
							min.	min.			
100	140	20	57	40,5	2 800	12 000	18 000	1,1	1,1	0,64	HCB71920-EDLR-T-P4S
	140	20	60	43	2 950	13 000	20 000	1,1	1,1	0,64	HCB71920-CDLR-T-P4S
	140	20	27	21,2	1 470	15 000	24 000	1,1	1,1	0,8	HC71920-EDLR-T-P4S
	140	20	41	21,2	1 470	17 000	26 000	1,1	1,1	0,8	XC71920-EDLR-T-P4S
	150	24	79	52	3 550	11 000	17 000	1,5	1,5	1,01	HCB7020-EDLR-T-P4S
	150	24	83	55	3 750	13 000	19 000	1,5	1,5	1,01	HCB7020-CDLR-T-P4S
	150	24	34,5	26	1 760	15 000	22 000	1,5	1,5	1,27	HC7020-EDLR-T-P4S
	150	24	53	26	1 760	16 000	24 000	1,5	1,5	1,27	XC7020-EDLR-T-P4S
105	145	20	57	41	2 800	11 000	17 000	1,1	1,1	0,68	HCB71921-EDLR-T-P4S
	145	20	60	43	2 950	13 000	19 000	1,1	1,1	0,68	HCB71921-CDLR-T-P4S
	145	20	27,5	22,4	1 530	15 000	22 000	1,1	1,1	0,82	HC71921-EDLR-T-P4S
	145	20	42	22,4	1 530	16 000	24 000	1,1	1,1	0,82	XC71921-EDLR-T-P4S
	160	26	80	55	3 650	11 000	16 000	2	2	1,36	HCB7021-EDLR-T-P4S
	160	26	85	58	3 850	12 000	18 000	2	2	1,36	HCB7021-CDLR-T-P4S
	160	26	45	33	2 180	14 000	22 000	2	2	1,56	HC7021-EDLR-T-P4S
	160	26	69	33	2 180	15 000	24 000	2	2	1,56	XC7021-EDLR-T-P4S
110	150	20	58	42,5	2 850	11 000	17 000	1,1	1,1	0,69	HCB71922-EDLR-T-P4S
	150	20	61	45	3 000	12 000	19 000	1,1	1,1	0,69	HCB71922-CDLR-T-P4S
	150	20	32	26	1 720	14 000	22 000	1,1	1,1	0,82	HC71922-EDLR-T-P4S
	150	20	49	26	1 720	16 000	24 000	1,1	1,1	0,82	XC71922-EDLR-T-P4S
	170	28	106	70	4 500	11 000	16 000	2	2	1,59	HCB7022-EDLR-T-P4S
	170	28	112	74	4 750	12 000	18 000	2	2	1,59	HCB7022-CDLR-T-P4S
	170	28	45,5	34	2 200	13 000	20 000	2	2	2,02	HC7022-EDLR-T-P4S
	170	28	69	34	2 200	14 000	22 000	2	2	2,02	XC7022-EDLR-T-P4S

medias ► <https://www.schaeffler.de/std/1D73>

- 1) The limiting speeds are based on elastically preloaded single bearings.
- 2) Explanation of designations ► [SP 1](#).
- 3) L = light preload; M = moderate preload; H = high preload.
- 4) Minimal quantity oil lubrication.

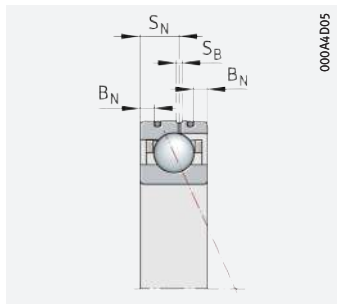

Design DLR

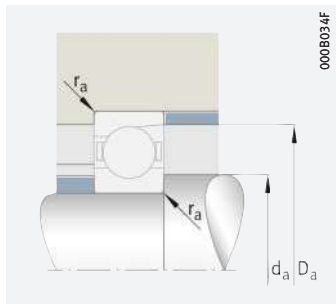

Mounting dimensions

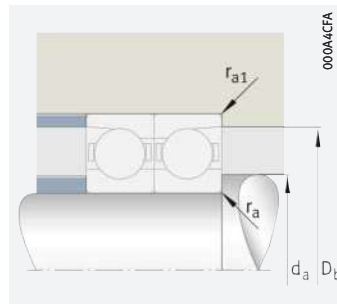

Mounting dimensions

Dimensions	Contact angle				Mounting dimensions				Preload force ³⁾			Lift-off force ³⁾			Axial rigidity ³⁾			
	d	B _N	S _N	S _B	α	d _a h12	D _a H12	r _a max.	r _{a1} max.	L	M	H	L	M	H	L	M	H
				°						N	N	N	N	N	N	N/μm	N/μm	N/μm
100	4	12	2,2	25	107	133	0,6	0,6	204	850	1876	584	2489	5611	187	311	421	
	4	12	2,2	15	107	133	0,6	0,6	160	572	1201	473	1789	3950	80,4	135	189	
	4	12	2,2	25	107	133	0,6	0,6	109	328	656	313	951	1927	162	239	307	
	4	12	2,2	25	107	133	0,6	0,6	109	328	656	313	951	1927	162	239	307	
	5,5	14,5	2,2	25	110	141	1,5	0,6	333	1266	2723	957	3715	8170	212	343	459	
	5,5	14,5	2,2	15	110	141	1,5	0,6	241	823	1703	717	2587	5636	89,1	148	206	
	5,5	14,5	2,2	25	110	141	1,5	0,6	144	431	863	412	1252	2539	171	253	326	
	5,5	14,5	2,2	25	110	141	1,5	0,6	144	431	863	412	1252	2539	171	253	326	
105	4	12	2,2	25	112	138	0,6	0,6	204	850	1876	584	2489	5611	187	311	421	
	4	12	2,2	15	112	138	0,6	0,6	157	564	1185	466	1763	3895	80	134	188	
	4	12	2,2	25	112	138	0,6	0,6	113	338	676	323	980	1987	170	250	321	
	4	12	2,2	25	112	138	0,6	0,6	113	338	676	323	980	1987	170	250	321	
	5,5	15,5	2,2	25	116	150	2	1	336	1285	2768	966	3768	8297	219	355	476	
	5,5	15,5	2,2	15	116	150	2	1	244	836	1732	725	2623	5718	92,1	153	213	
	5,5	15,5	2,2	25	116	150	2	1	184	552	1104	527	1602	3250	188	277	357	
	5,5	15,5	2,2	25	116	150	2	1	184	552	1104	527	1602	3250	188	277	357	
110	4	12	2,2	25	117	143	0,6	0,6	208	871	1923	596	2547	5747	193	322	435	
	4	12	2,2	15	117	143	0,6	0,6	158	570	1199	468	1777	3931	82,1	138	193	
	4	12	2,2	25	117	143	0,6	0,6	131	393	787	375	1141	2312	178	262	337	
	4	12	2,2	25	117	143	0,6	0,6	131	393	787	375	1141	2312	178	262	337	
	6	16,2	2,2	25	121	159	2	1	490	1779	3778	1409	5224	11341	248	395	527	
	6	16,2	2,2	15	121	159	2	1	337	1126	2314	1004	3540	7655	103	169	234	
	6	16,2	2,2	25	121	159	2	1	187	561	1121	535	1627	3299	193	284	366	
	6	16,2	2,2	25	121	159	2	1	187	561	1121	535	1627	3299	193	284	366	





Super precision cylindrical roller bearings

Single row
Steel or ceramic rollers

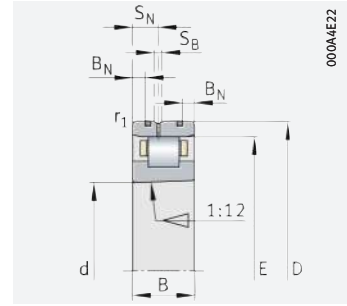
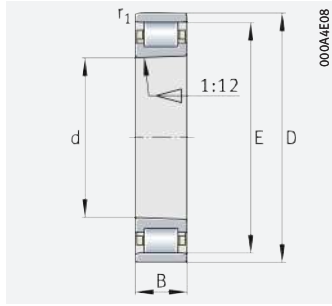

Direct Lube

d = 30 – 55 mm

Main dimensions			Basic load ratings		Fatigue limit load C_{ur} N	Limiting speeds		Mass m ≈ kg	Designation ¹⁾ X-life ▶ 1176
d	D	B	dyn. C_r N	stat. C_{0r} N		n_G grease min ⁻¹	n_G oil ²⁾ min ⁻¹		
30	55	13	17 500	15 600	2 230	21 700	25 500	0,12	N1006-D-K-TVP-SP-XL
	55	13	20 200	20 400	2 600	33 500	39 500	0,12	N1006-K-PVPA1-SP
	55	13	20 200	19 200	1 830	36 500	43 000	0,11	HCN1006-K-PVPA1-SP
35	62	14	23 600	20 900	3 300	18 700	22 000	0,16	N1007-D-K-TVP-SP-XL
	62	14	19 900	20 900	2 650	30 000	35 000	0,16	N1007-C-K-PVPA1-SP
	62	14	19 900	19 600	1 890	32 500	38 500	0,14	HCN1007-C-K-PVPA1-SP
40	68	15	27 000	26 000	4 100	17 100	20 100	0,2	N1008-D-K-TVP-SP-XL
	68	15	27 500	29 000	3 600	26 500	31 000	0,19	N1008-K-PVPA1-SP
	68	15	27 500	27 000	2 600	29 000	34 000	0,16	HCN1008-K-PVPA1-SP
45	75	16	34 500	32 500	5 000	15 200	17 800	0,24	N1009-D-K-TVP-SP-XL
	75	16	29 000	32 500	4 050	24 400	28 500	0,24	N1009-C-K-PVPA1-SP
	75	16	29 000	31 000	2 950	26 500	31 000	0,22	HCN1009-C-K-PVPA1-SP
50	80	16	36 500	36 500	5 600	14 200	16 800	0,27	N1010-D-K-TVP-SP-XL
	80	16	31 000	36 500	4 500	22 800	27 000	0,27	N1010-C-K-PVPA1-SP
	80	16	31 000	34 000	3 300	24 900	29 500	0,23	HCN1010-C-K-PVPA1-SP
55	90	18	48 000	48 500	7 700	12 600	14 800	0,4	N1011-D-K-TVP-SP-XL
	90	18	40 500	48 000	6 300	20 200	23 800	0,4	N1011-K-PVPA1-SP
	90	18	40 500	45 500	4 550	22 100	26 000	0,34	HCN1011-K-PVPA1-SP

medias ▶ <https://www.schaeffler.de/std/1D74>

1) The bearings are also available by agreement in the following designs:

- With cylindrical bore (without suffix K), ordering example: N1006-D-TVP-SP-XL
- As Direct Lube design (suffix DLR), ordering example: N1006-K-DLR-PVPA1-SP.

Series HCN10 is available by agreement in the following design from d = 30 mm to d = 120 mm:

- With half the number of rollers for higher limiting speeds (suffix H193), ordering example: HCN1024-K-PVPA1-SP-H193.

2) Minimal quantity oil lubrication.

3) Axial displacement of outer ring from central position.

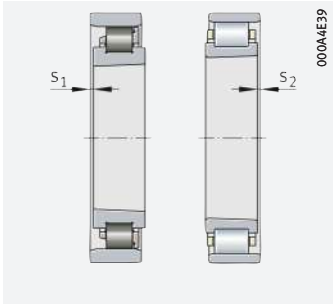

Axial displacement

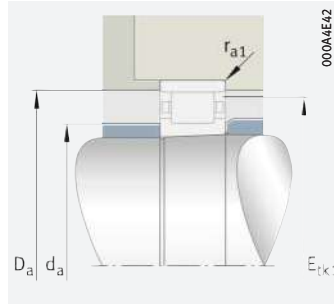

Mounting dimensions

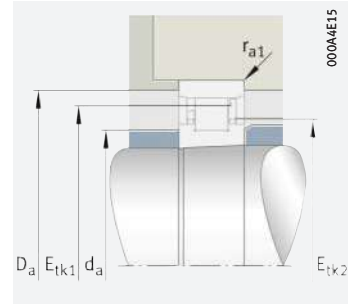

Mounting dimensions for bearings with PVPA1 cage

Dimensions								Mounting dimensions				
d	r ₁	E	B _N	S _N	S _B	s ₁ ³⁾	s ₂ ³⁾	d _a h12	D _a H12	E _{tk1}	E _{tk2}	r _{a1}
	min.									nom.	nom.	max.
30	0,6	48,5	2,8	7,2	1,4	2,8	2,8	38,5	49,5	47,5	–	0,6
	0,6	48,5	2,8	7,2	1,4	0,85	2,2	36,5	49,4	47	39,7	0,6
	0,6	48,5	2,8	7,2	1,4	0,85	2,2	36,5	49,4	47	39,7	0,6
35	0,6	55	2,8	8	1,4	2,8	2,8	43	56	53,9	–	0,6
	0,6	55	2,8	8	1,4	0,9	2,4	43	56,1	53,4	45,8	0,6
	0,6	55	2,8	8	1,4	0,9	2,4	43	56,1	53,4	45,8	0,6
40	0,6	61	2,8	8,5	1,4	3,1	3,1	49	62,1	59,8	–	0,6
	0,6	61	2,8	8,5	1,4	0,95	2,5	47	62,1	59,3	50,8	0,6
	0,6	61	2,8	8,5	1,4	0,95	2,5	47	62,1	59,3	50,8	0,6
45	0,6	67,5	3,4	9,3	1,4	3,1	3,1	53,5	68,6	66,2	–	0,6
	0,6	67,5	3,4	9,3	1,4	1,2	2,5	53,5	68,7	65,6	56,9	0,6
	0,6	67,5	3,4	9,3	1,4	1,2	2,5	53,5	68,7	65,6	56,9	0,6
50	0,6	72,5	3,4	9,3	1,4	3,1	3,1	58,5	73,6	71,2	–	0,6
	0,6	72,5	3,4	9,3	1,4	1,15	2,7	58,5	73,7	70,6	61,9	0,6
	0,6	72,5	3,4	9,3	1,4	1,15	2,7	58,5	73,7	70,6	61,9	0,6
55	1	81	4,3	9,7	1,4	3,4	3,4	65	82,2	79,3	–	1
	1	80,5	4,3	9,7	1,4	1,4	3	64,5	81,8	78,5	68,8	1
	1	80,5	4,3	9,7	1,4	1,4	3	64,5	81,8	78,5	68,8	1





Super precision cylindrical roller bearings

Single row
Steel or ceramic rollers

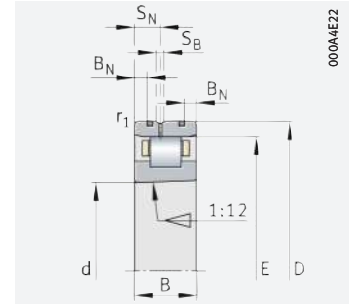
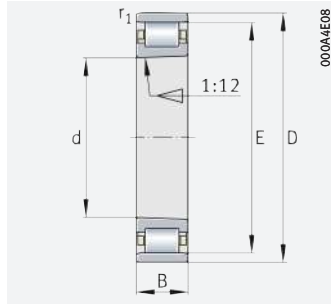

Direct Lube

d = 60 – 85 mm

Main dimensions			Basic load ratings		Fatigue limit load	Limiting speeds		Mass	Designation ¹⁾
d	D	B	dyn. C _r N	stat. C _{0r} N	C _{ur} N	n _G grease min ⁻¹	n _G oil ²⁾ min ⁻¹	m ≈ kg	X-life ▶ 1176
60	95	18	51 000	53 000	8 500	11 900	14 000	0,43	
	95	18	43 000	53 000	6 900	19 200	22 600	0,42	N1012-K-PVPA1-SP
	95	18	43 000	50 000	5 000	21 000	24 700	0,37	HCN1012-K-PVPA1-SP
65	100	18	53 000	58 000	9 300	11 400	13 400	0,45	N1013-D-K-TVP-SP-XL
	100	18	45 000	58 000	7 600	18 200	21 400	0,45	N1013-C-K-PVPA1-SP
	100	18	45 000	54 000	5 500	19 900	23 400	0,4	HCN1013-C-K-PVPA1-SP
70	110	20	66 000	72 000	10 400	10 200	12 000	0,64	N1014-D-K-TVP-SP-XL
	110	20	63 000	77 000	9 200	16 000	18 800	0,61	N1014-K-PVPA1-SP
	110	20	61 000	70 000	7 400	17 500	20 600	0,52	HCN1014-K-PVPA1-SP
75	115	20	65 000	73 000	10 500	9 800	11 500	0,67	N1015-D-K-TVP-SP-XL
	115	20	66 000	85 000	10 200	15 300	18 000	0,65	N1015-K-PVPA1-SP
	115	20	65 000	77 000	8 100	16 800	19 700	0,56	HCN1015-K-PVPA1-SP
80	125	22	81 000	91 000	13 700	9 000	10 600	0,9	N1016-D-K-TVP-SP-XL
	125	22	77 000	99 000	12 700	14 000	16 500	0,88	N1016-K-PVPA1-SP
	125	22	77 000	93 000	10 100	15 300	18 100	0,76	HCN1016-K-PVPA1-SP
85	130	22	80 000	91 000	13 500	8 700	10 200	0,95	N1017-D-K-TVP-SP-XL
	130	22	76 000	99 000	12 600	13 500	15 900	1	N1017-K-PVPA1-SP
	130	22	76 000	93 000	10 000	14 800	17 400	0,89	HCN1017-K-PVPA1-SP

medias ▶ <https://www.schaeffler.de/std/1D75>

1) The bearings are also available by agreement in the following designs:

- With cylindrical bore (without suffix K), ordering example: N1006-D-TVP-SP-XL
- As Direct Lube design (suffix DLR), ordering example: N1006-K-DLR-PVPA1-SP.

Series HCN10 is available by agreement in the following design from d = 30 mm to d = 120 mm:

- With half the number of rollers for higher limiting speeds (suffix H193), ordering example: HCN1024-K-PVPA1-SP-H193.

2) Minimal quantity oil lubrication.

3) Axial displacement of outer ring from central position.

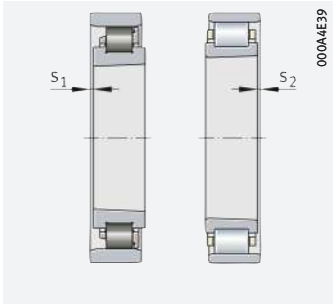

Axial displacement

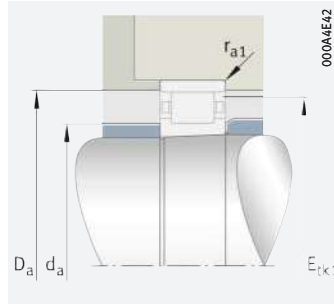

Mounting dimensions

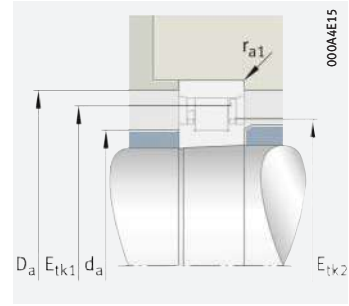

Mounting dimensions for bearings with PVPA1 cage

Dimensions								Mounting dimensions				
d	r ₁	E	B _N	S _N	S _B	s ₁ ³⁾	s ₂ ³⁾	d _a	D _a	E _{tk1}	E _{tk2}	r _{a1}
	min.							h12	H12	nom.	nom.	max.
60	1	86,1	4,3	9,7	1,4	3,4	3,4	70,1	87,3	84,4	–	1
	1	85,5	4,3	9,7	1,4	1,25	3	69,5	86,8	83,5	73,8	1
	1	85,5	4,3	9,7	1,4	1,25	3	69,5	86,8	83,5	73,8	1
65	1	91	4	10,4	1,4	3,4	3,4	75	92,2	89,3	–	1
	1	91	4	10,4	1,4	1,4	2,5	75	92,3	88,5	78,7	1
	1	91	4	10,4	1,4	1,4	2,5	75	92,3	88,5	78,7	1
70	1	100	4	11,6	1,4	3,8	3,8	82	101,3	98,2	–	1
	1	100	4	11,6	1,4	1,25	3,3	80	101,3	97,5	85,4	1
	1	100	4	11,6	1,4	1,25	3,3	80	101,3	97,5	85,4	1
75	1	105	4	11,6	1,4	3,8	3,8	87	106,3	103,2	–	1
	1	105	4	11,6	1,4	1	3	85	106,3	102,5	90,4	1
	1	105	4	11,6	1,4	1	3	85	106,3	102,5	90,4	1
80	1	113	4,7	12,2	2,2	4,1	4,1	93	114,4	111,4	–	1
	1	113,5	4,7	12,2	2,2	1,1	3,5	91,5	115	110,8	97,4	1
	1	113,5	4,7	12,2	2,2	1,1	3,5	91,5	115	110,8	97,4	1
85	1	118	4,7	12,2	2,2	4,1	4,1	98	119,4	116,3	–	1
	1	118,5	4,7	12,2	2,2	1,5	2,7	96,5	120	115,8	102,4	1
	1	118,5	4,7	12,2	2,2	1,5	2,7	96,5	120	115,8	102,4	1





Super precision cylindrical roller bearings

Single row
Steel or ceramic rollers

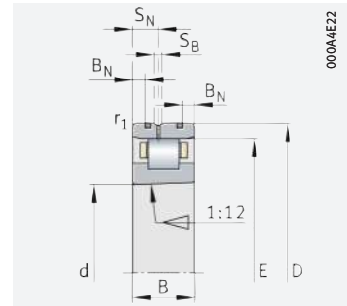
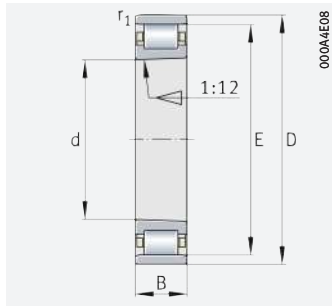

Direct Lube

d = 90 – 120 mm

Main dimensions			Basic load ratings		Fatigue limit load C_{ur} N	Limiting speeds		Mass m ≈ kg	Designation ¹⁾ X-life ▶ 1176
d	D	B	dyn. C_r N	stat. C_{0r} N		n_G grease min ⁻¹	n_G oil ⁽²⁾ min ⁻¹		
90	140	24	95 000	108 000	16 500	8 000	9 400	1,23	N1018-D-K-TVP-SP-XL
	140	24	91 000	119 000	15 200	12 500	14 700	1,2	N1018-K-PVPA1-SP
	140	24	91 000	112 000	12 000	13 700	16 100	1,06	HCN1018-K-PVPA1-SP
95	145	24	99 000	117 000	17 700	7 700	9 100	1,29	N1019-D-K-TVP-SP-XL
	145	24	96 000	130 000	16 400	12 100	14 200	1,26	N1019-K-PVPA1-SP
	145	24	96 000	122 000	12 900	13 200	15 600	1,2	HCN1019-K-PVPA1-SP
100	150	24	99 000	118 000	17 500	7 500	8 800	1,34	N1020-D-K-TVP-SP-XL
	150	24	95 000	130 000	16 200	11 700	13 800	1,29	N1020-K-PVPA1-SP
	150	24	95 000	123 000	12 800	12 800	15 100	1,2	HCN1020-K-PVPA1-SP
105	160	26	132 000	154 000	24 000	6 800	8 000	1,67	N1021-D-K-TVP-SP-XL
	160	26	112 000	154 000	19 400	10 900	12 900	1,66	N1021-K-PVPA1-SP
	160	26	111 000	144 000	14 400	11 900	14 100	1,6	HCN1021-K-PVPA1-SP
110	170	28	153 000	180 000	28 000	6 400	7 500	2,06	N1022-D-K-TVP-SP-XL
	170	28	141 000	191 000	24 400	10 000	11 800	2,02	N1022-K-PVPA1-SP
	170	28	141 000	180 000	18 000	11 000	12 900	1,9	HCN1022-K-PVPA1-SP
120	180	28	160 000	196 000	30 000	6 000	7 100	2,22	N1024-D-K-TVP-SP-XL
	180	28	148 000	208 000	26 000	9 500	11 200	2,18	N1024-K-PVPA1-SP
	180	28	147 000	195 000	19 300	10 400	12 200	2,05	HCN1024-K-PVPA1-SP

medias ▶ <https://www.schaeffler.de/std/1D76>

1) The bearings are also available by agreement in the following designs:

- With cylindrical bore (without suffix K), ordering example: N1006-D-TVP-SP-XL
- As Direct Lube design (suffix DLR), ordering example: N1006-K-DLR-PVPA1-SP.

Series HCN10 is available by agreement in the following design from d = 30 mm to d = 120 mm:

- With half the number of rollers for higher limiting speeds (suffix H193), ordering example: HCN1024-K-PVPA1-SP-H193.

2) Minimal quantity oil lubrication.

3) Axial displacement of outer ring from central position.

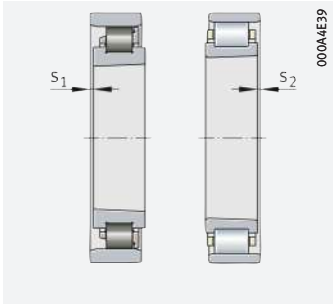

Axial displacement

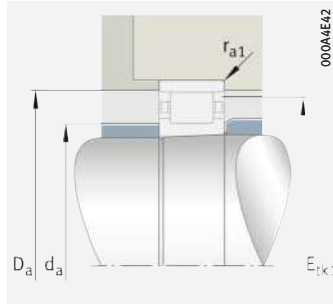

Mounting dimensions

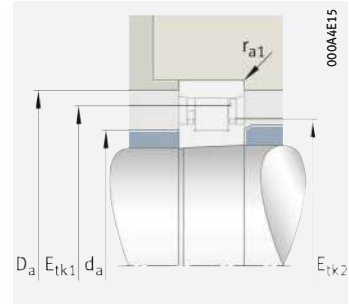

Mounting dimensions for bearings with PVPA1 cage

Dimensions								Mounting dimensions				
d	r ₁	E	B _N	S _N	S _B	s ₁ ³⁾	s ₂ ³⁾	d _a h12	D _a H12	E _{tk1}	E _{tk2}	r _{a1}
	min.									nom.	nom.	max.
90	1,1	127	5,5	14,5	2,2	4,4	4,4	105	128,5	124,9	–	1
	1,1	127	5,5	14,5	2,2	1,2	3,7	103	128,6	124	109,4	1
	1,1	127	5,5	14,5	2,2	1,2	3,7	103	128,6	124	109,4	1
95	1,1	132	5,5	14,5	2,2	4,4	4,4	110	133,5	129,8	–	1
	1,1	132	5,5	14,5	2,2	1,2	3,7	108	133,6	129	114,4	1
	1,1	132	5,5	14,5	2,2	1,2	3,7	108	133,6	129	114,4	1
100	1,1	137	5,5	14,5	2,2	4,4	4,4	115	138,5	134,8	–	1
	1,1	137	5,5	14,5	2,2	1,1	3,5	113	138,6	134	119,4	1
	1,1	137	5,5	14,5	2,2	1,1	3,5	113	138,6	134	119,4	1
105	1,1	146	6	15,2	2,2	4,5	4,5	120	147,5	143,5	–	1
	1,1	145,5	6	15,2	2,2	0,6	3,2	119,5	147,2	142,3	126,5	1
	1,1	145,5	6	15,2	2,2	0,6	3,2	119,5	147,2	142,3	126,5	1
110	1,1	155	6	16,2	2,2	4,8	4,8	127	156,6	152,4	–	1
	1,1	155	6	16,2	2,2	1	4	125	156,7	151,3	133,1	1
	1,1	155	6	16,2	2,2	1	4	125	156,7	151,3	133,1	1
120	1,1	165	6	16,2	2,2	4,8	4,8	137	166,6	162,4	–	1
	1,1	165	6	16,2	2,2	1	4	135	166,7	161,3	143,1	1
	1,1	165	6	16,2	2,2	1	4	135	166,7	161,3	143,1	1





Super precision cylindrical roller bearings

Single row
Steel rollers

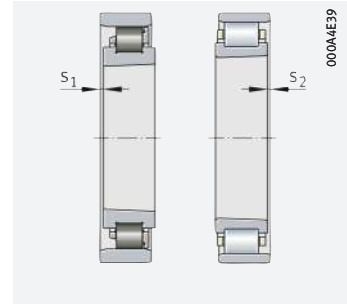
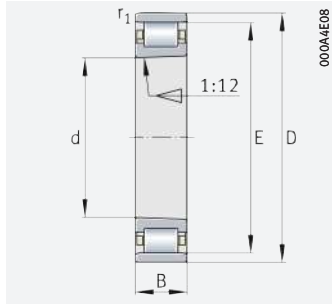

Axial displacement

d = 130 – 200 mm

Main dimensions			Basic load ratings		Fatigue limit load C_{ur} N	Limiting speeds		Mass m ≈ kg	Designation ¹⁾²⁾ X-life ▶ 1176
d	D	B	dyn. C_r N	stat. C_{0r} N		n_G grease min ⁻¹	n_G oil ³⁾ min ⁻¹		
130	200	33	179 000	250 000	31 500	4 800	5 600	3,72	N1026-K-M1-SP
140	210	33	183 000	265 000	32 500	4 550	5 400	3,85	N1028-K-M1-SP
150	225	35	210 000	310 000	38 000	4 250	5 000	4,81	N1030-K-M1-SP
160	240	38	245 000	355 000	43 500	3 900	4 600	5,76	N1032-K-M1-SP
170	260	42	295 000	435 000	52 000	3 600	4 250	7,77	N1034-K-M1-SP
180	280	46	360 000	520 000	63 000	3 300	3 850	10,2	N1036-K-M1-SP
190	290	46	370 000	550 000	66 000	3 200	3 750	10,6	N1038-K-M1-SP
200	310	51	395 000	600 000	71 000	3 000	3 500	13,7	N1040-K-M1-SP

medias ▶ <https://www.schaeffler.de/std/1D77>

- 1) The bearings are also available by agreement in the following designs:
 - With cylindrical bore (without suffix K), ordering example: N1026-M1-SP.
- 2) Bearings with a larger diameter are available by agreement.
- 3) Minimal quantity oil lubrication.
- 4) Axial displacement of outer ring from central position.

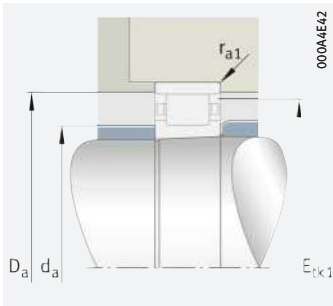

Mounting dimensions

Dimensions					Mounting dimensions			
d	r ₁ min.	E	s ₁ ⁴⁾	s ₂ ⁴⁾	d _a h12	D _a H12	E _{tk1} nom.	r _{a1} max.
130	1,1	182	4,2	4,2	148	184,1	177,8	1
140	1,1	192	4,2	4,2	158	194,1	187,8	1
150	1,5	205,5	4,4	4,4	169,5	207,8	201	1,5
160	1,5	220	4,6	4,6	180	222,4	215	1,5
170	2,1	237	5	5	193	239,7	231,5	2,1
180	2,1	255	5,6	5,6	205	257,8	248,8	2,1
190	2,1	265	5,6	5,6	215	267,8	258,8	2,1
200	2,1	281	6,4	6,4	229	284,3	274,5	2,1





Super precision cylindrical roller bearings

Double row
Non-locating bearings

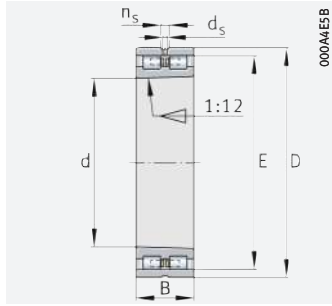

NN30

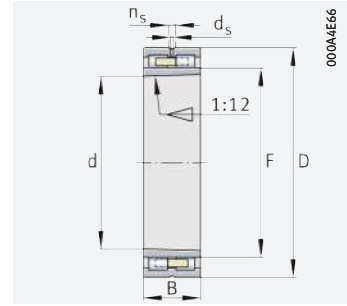

NNU49

d = 30 – 120 mm

Main dimensions			Basic load ratings		Fatigue limit load C_{ur} N	Limiting speeds		Mass m ≈ kg	Designation ¹⁾ X-life ▶ 1176
d	D	B	dyn. C_r N	stat. C_{Or} N		n_G grease min ⁻¹	n_G oil ²⁾ min ⁻¹		
30	55	19	30 000	31 000	4 450	20 600	24 200	0,18	NN3006-D-K-TVP-SP-XL
35	62	20	40 500	41 500	6 600	17 800	20 900	0,24	NN3007-D-K-TVP-SP-XL
40	68	21	46 500	52 000	8 200	16 200	19 100	0,28	NN3008-D-K-TVP-SP-XL
45	75	23	59 000	65 000	10 000	14 400	16 900	0,36	NN3009-D-K-TVP-SP-XL
50	80	23	63 000	73 000	11 100	13 500	15 900	0,39	NN3010-D-K-TVP-SP-XL
55	90	26	82 000	97 000	15 500	11 900	14 100	0,59	NN3011-D-K-TVP-SP-XL
60	95	26	87 000	106 000	17 100	11 300	13 300	0,63	NN3012-D-K-TVP-SP-XL
65	100	26	91 000	116 000	18 600	10 800	12 700	0,67	NN3013-D-K-TVP-SP-XL
70	110	30	113 000	145 000	20 900	9 700	11 400	0,98	NN3014-D-K-TVP-SP-XL
75	115	30	112 000	146 000	21 000	9 300	11 000	1,02	NN3015-D-K-TVP-SP-XL
80	125	34	139 000	182 000	27 500	8 500	10 000	1,42	NN3016-D-K-TVP-SP-XL
85	130	34	138 000	183 000	27 000	8 200	9 700	1,48	NN3017-D-K-TVP-SP-XL
90	140	37	162 000	216 000	33 000	7 600	8 900	1,93	NN3018-D-K-TVP-SP-XL
95	145	37	170 000	234 000	35 500	7 300	8 600	2,03	NN3019-D-K-TVP-SP-XL
100	140	40	128 000	255 000	33 000	5 700	6 700	1,88	NNU4920-S-K-M-SP
	150	37	169 000	235 000	35 000	7 100	8 300	2,09	NN3020-D-K-TVP-SP-XL
105	145	40	130 000	260 000	34 000	5 500	6 500	1,93	NNU4921-S-K-M-SP
	160	41	226 000	310 000	48 000	6 500	7 600	2,68	NN3021-D-K-TVP-SP-XL
110	150	40	132 000	270 000	34 500	5 400	6 300	2,01	NNU4922-S-K-M-SP
	170	45	260 000	360 000	56 000	6 000	7 100	3,41	NN3022-D-K-TVP-SP-XL
120	165	45	175 000	340 000	40 500	4 750	5 600	2,78	NNU4924-S-K-M-SP
	180	46	275 000	390 000	60 000	5 700	6 700	3,72	NN3024-D-K-TVP-SP-XL

medias ▶ <https://www.schaeffler.de/std/1D78>

- 1) The bearings are also available with a cylindrical bore (without suffix K), ordering example: NN3006-D-TVP-SP-XL.
- 2) Minimal quantity oil lubrication.
- 3) Axial displacement of outer ring from central position.

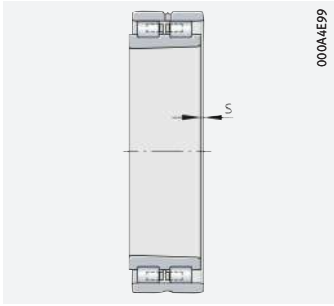

Axial displacement

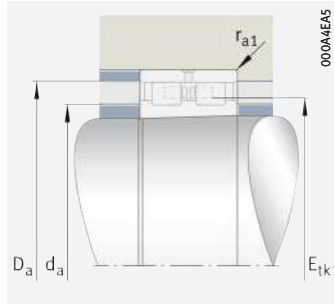

Mounting dimensions

Dimensions							Mounting dimensions		
d	r ₁ min.	s ³⁾	E	F	n _s	d _s	d _a h12	D _a H12	r _{a1} max.
30	1	1,7	48,5	–	–	–	38,5	50	1
35	1	1,4	55	–	–	–	43	56,5	1
40	1	1,7	61	–	–	–	49	62,6	1
45	1	1,7	67,5	–	–	–	53,5	69,2	1
50	1	1,7	72,5	–	–	–	58,5	74,2	1
55	1,1	1,9	81	–	–	–	65	82,9	1
60	1,1	1,9	86,1	–	–	–	70,1	88	1
65	1,1	1,9	91	–	–	–	75	92,9	1
70	1,1	2,3	100	–	–	–	82	102,3	1
75	1,1	2,3	105	–	–	–	87	107,3	1
80	1,1	2,5	113	–	–	–	93	115,6	1
85	1,1	2,5	118	–	–	–	98	120,6	1
90	1,5	2,5	127	–	–	–	105	129,8	1,5
95	1,5	2,5	132	–	–	–	110	134,8	1,5
100	1,1	2	–	113	3,2	6,5	112	129	1
	1,5	2,5	137	–	–	–	115	139,8	1,5
105	1,1	2	–	118	3,2	6,5	117	134	1
	2	2,6	146	–	–	–	120	149	2
110	1,1	2	–	123	3,2	6,5	122	139	1
	2	2,9	155	–	–	–	127	158,3	2
120	1,1	2,3	–	134,5	3,2	6,5	133,4	154,5	1
	2	3,1	165	–	–	–	137	168,4	2





Super precision cylindrical roller bearings

Double row
Non-locating bearings

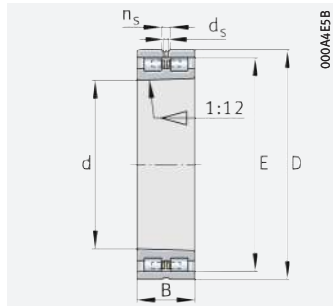

NN30

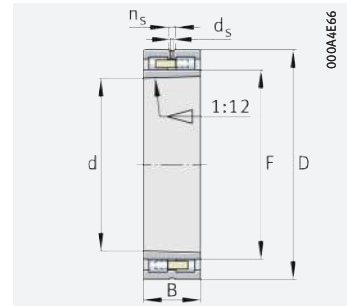

NNU49

d = 130 – 300 mm

Main dimensions			Basic load ratings		Fatigue limit load C_{ur} N	Limiting speeds		Mass m ≈ kg	Designation ¹⁾
d	D	B	dyn. C_r N	stat. C_{0r} N		n_G grease min ⁻¹	n_G oil ²⁾ min ⁻¹		
130	180	50	188 000	385 000	45 000	4 450	5 300	3,81	NNU4926-S-K-M-SP
	200	52	295 000	500 000	62 000	4 100	4 800	5,84	NN3026-AS-K-M-SP
140	190	50	190 000	400 000	45 500	4 250	5 000	4,04	NNU4928-S-K-M-SP
	210	53	300 000	520 000	63 000	3 900	4 600	6,22	NN3028-AS-K-M-SP
150	210	60	330 000	650 000	81 000	3 550	4 200	6,1	NNU4930-S-K-M-SP
	225	56	335 000	590 000	72 000	3 650	4 250	7,59	NN3030-AS-K-M-SP
160	220	60	335 000	680 000	83 000	3 400	4 000	6,46	NNU4932-S-K-M-SP
	240	60	375 000	670 000	80 000	3 400	4 000	9,23	NN3032-AS-K-M-SP
170	230	60	340 000	700 000	84 000	3 300	3 850	6,9	NNU4934-S-K-M-SP
	260	67	450 000	800 000	96 000	3 100	3 650	12,5	NN3034-AS-K-M-SP
180	250	69	405 000	860 000	102 000	3 000	3 550	9,96	NNU4936-S-K-M-SP
	280	74	570 000	1 000 000	117 000	2 850	3 300	16,4	NN3036-AS-K-M-SP
190	260	69	410 000	880 000	104 000	2 900	3 450	10,6	NNU4938-S-K-M-SP
	290	75	580 000	1 040 000	120 000	2 750	3 200	17,3	NN3038-AS-K-M-SP
200	280	80	490 000	1 040 000	123 000	2 700	3 200	14,7	NNU4940-S-K-M-SP
	310	82	660 000	1 190 000	140 000	2 550	3 000	22,2	NN3040-AS-K-M-SP
220	300	80	510 000	1 140 000	131 000	2 550	3 000	16,3	NNU4944-S-K-M-SP
	340	90	810 000	1 450 000	163 000	2 290	2 700	29,1	NN3044-AS-K-M-SP
240	320	80	530 000	1 210 000	136 000	2 400	2 800	17,1	NNU4948-S-K-M-SP
	360	92	840 000	1 580 000	174 000	2 170	2 550	31,5	NN3048-AS-K-M-SP
260	360	100	750 000	1 690 000	187 000	2 070	2 430	30,4	NNU4952-S-K-M-SP
	400	104	1 070 000	2 010 000	219 000	1 930	2 280	46,2	NN3052-AS-K-M-SP
280	380	100	770 000	1 790 000	195 000	1 970	2 320	32,5	NNU4956-S-K-M-SP
	420	106	1 090 000	2 090 000	225 000	1 850	2 170	49,7	NN3056-AS-K-M-SP
300	420	118	1 040 000	2 380 000	260 000	1 740	2 040	48,6	NNU4960-S-K-M-SP
	460	118	1 270 000	2 400 000	255 000	1 670	1 970	68,5	NN3060-AS-K-M-SP

medias ► <https://www.schaeffler.de/std/1D79>

- 1) The bearings are also available with a cylindrical bore (without suffix K), ordering example: NN3006-D-TVP-SP-XL.
- 2) Minimal quantity oil lubrication.
- 3) Axial displacement of outer ring from central position.

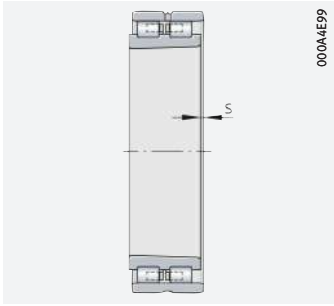

Axial displacement

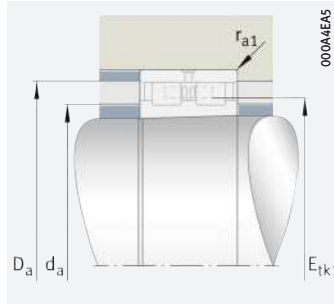

Mounting dimensions

Dimensions							Mounting dimensions		
d	r ₁	s ³⁾	E	F	n _s	d _s	d _a h12	D _a H12	r _{a1} max.
	min.								
130	1,5	2,7	–	146	3,2	6,5	144,7	166	1,5
	2	3,1	182	–	4,8	9,5	150	186	2
140	1,5	2,7	–	156	3,2	6,5	155,1	176	1,5
	2	3,4	192	–	4,8	9,5	160	196	2
150	2	2,7	–	168,5	3,2	6,5	167,2	196,5	2
	2,1	3,8	206	–	4,8	9,5	172	210	2,1
160	2	2,7	–	178,5	3,2	6,5	177,2	206,5	2
	2,1	4,3	219	–	4,8	9,5	183	224	2,1
170	2	2,7	–	188,5	3,2	6,5	187,2	216,5	2
	2,1	4,6	236	–	4,8	9,5	196	241	2,1
180	2	3,2	–	202	4,8	9,5	200,5	232	2
	2,1	4,8	255	–	6,3	12,2	209	260	2,1
190	2	3,2	–	212	4,8	9,5	210,5	242	2
	2,1	4,8	265	–	6,3	12,2	219	271	2,1
200	2,1	4,3	–	225	6,3	12,2	223	259	2,1
	2,1	5,7	282	–	6,3	12,2	232	288	2,1
220	2,1	4,3	–	245	6,3	12,2	243	279	2,1
	3	5,7	310	–	8	15	254	317	2,5
240	2,1	4,3	–	265	6,3	12,2	263	299	2,1
	3	6,1	330	–	8	15	274	337	2,5
260	2,1	5,4	–	292	8	15	289,4	334	2,1
	4	6,6	364	–	8	15	300	372	3
280	2,1	5,4	–	312	8	15	309,4	354	2,1
	4	6,9	384	–	8	15	320	392	3
300	3	6,3	–	339	9,5	17,7	336	389	2,5
	4	7,5	418	–	9,5	17,7	346	427	3





Super precision cylindrical roller bearings

Double row
Non-locating bearings

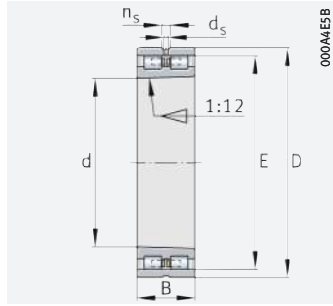

NN30

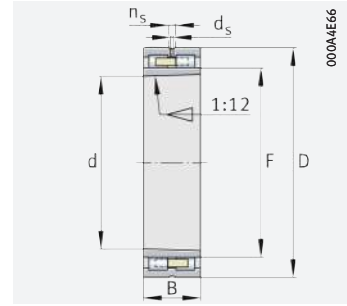

NNU49

d = 320 – 500 mm

Main dimensions			Basic load ratings		Fatigue limit load C_{ur} N	Limiting speeds		Mass m ≈ kg	Designation ¹⁾
d	D	B	dyn. C_r N	stat. C_{0r} N		n_G grease min^{-1}	n_G oil ²⁾ min^{-1}		
320	440	118	1 070 000	2 550 000	275 000	1 670	1 960	52,5	NNU4964-S-K-M-SP
	480	121	1 330 000	2 600 000	270 000	1 610	1 890	73,8	NN3064-AS-K-M-SP
340	460	118	1 100 000	2 650 000	285 000	1 600	1 890	55,7	NNU4968-S-K-M-SP
	520	133	1 640 000	3 250 000	335 000	1 470	1 730	99,3	NN3068-AS-K-M-SP
360	480	118	1 130 000	2 800 000	295 000	1 540	1 820	57,3	NNU4972-S-K-M-SP
	540	134	1 670 000	3 350 000	345 000	1 420	1 670	104	NN3072-AS-K-M-SP
380	520	140	1 440 000	3 600 000	370 000	1 380	1 620	86,9	NNU4976-S-K-M-SP
	560	135	1 700 000	3 500 000	350 000	1 370	1 620	110	NN3076-AS-K-M-SP
400	540	140	1 490 000	3 800 000	385 000	1 330	1 570	91	NNU4980-S-K-M-SP
	600	148	2 150 000	4 450 000	435 000	1 260	1 480	143	NN3080-AS-K-M-SP
420	560	140	1 530 000	4 000 000	400 000	1 290	1 520	94,4	NNU4984-S-K-M-SP
	620	150	2 140 000	4 450 000	435 000	1 220	1 440	150	NN3084-AS-K-M-SP
440	600	160	2 040 000	5 200 000	520 000	1 150	1 360	130	NNU4988-S-K-M-SP
	650	157	2 430 000	5 100 000	490 000	1 160	1 360	172	NN3088-AS-K-M-SP
460	620	160	2 110 000	5 500 000	550 000	1 120	1 320	134	NNU4992-S-K-M-SP
	680	163	2 600 000	5 400 000	495 000	1 100	1 300	197	NN3092-AS-K-M-SP
480	650	170	2 350 000	6 100 000	600 000	1 060	1 250	158	NNU4996-S-K-M-SP
	700	165	2 700 000	5 800 000	530 000	1 070	1 260	208	NN3096-AS-K-M-SP
500	670	170	2 330 000	6 100 000	590 000	1 030	1 220	163	NNU49/500-S-K-M-SP
	720	167	2 700 000	5 800 000	520 000	1 050	1 230	214	NN30/500-AS-K-M-SP

medias ► <https://www.schaeffler.de/std/1D7A>

- 1) The bearings are also available with a cylindrical bore (without suffix K), ordering example: NN3006-D-TVP-SP-XL.
- 2) Minimal quantity oil lubrication.
- 3) Axial displacement of outer ring from central position.

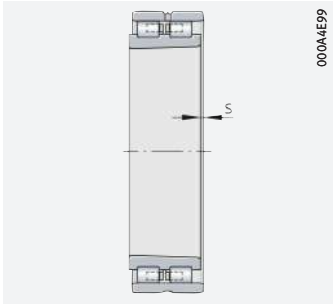

00044E99

Axial displacement

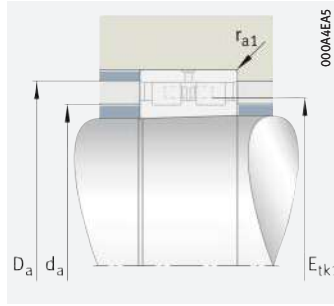

00044E45

Mounting dimensions

Dimensions							Mounting dimensions		
d	r ₁	s ³⁾	E	F	n _s	d _s	d _a h12	D _a H12	r _{a1} max.
	min.								
320	3	6,3	–	359	9,5	17,7	356	409	2,5
	4	8	438	–	9,5	17,7	366	447	3
340	3	6,3	–	379	9,5	17,7	376	429	2,5
	5	8,8	473	–	9,5	17,7	393	483	4
360	3	6,3	–	399	9,5	17,7	396	449	2,5
	5	8,8	493	–	9,5	17,7	413	503	4
380	4	7,2	–	426	9,5	17,7	422,6	482	3
	5	9,1	513	–	9,5	17,7	433	523	4
400	4	7,2	–	446	9,5	17,7	442,6	502	3
	5	9,5	549	–	9,5	17,7	459	560	4
420	4	7,2	–	466	9,5	17,7	462,6	522	3
	5	10	569	–	9,5	17,7	479	580	4
440	4	6,8	–	490	9,5	17,7	486,8	558	3
	6	10,2	597	–	12,5	23,5	501	609	5
460	4	6,8	–	510	9,5	17,7	506,8	578	3
	6	10,9	624	–	12,5	23,5	524	636	5
480	5	7,2	–	534	9,5	17,7	530,6	606	4
	6	11,2	644	–	12,5	23,5	544	656	5
500	5	7,2	–	554	9,5	17,7	550,6	626	4
	6	11,7	664	–	12,5	23,5	564	677	5





Super precision axial angular contact ball bearings 2344

Double direction

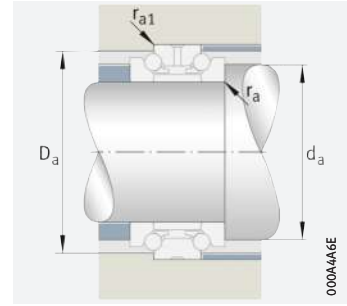
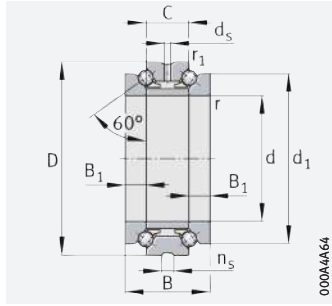

Mounting dimensions

d = 30 – 280 mm

Main dimensions				Basic load ratings		Fatigue limit load	Limiting speeds		Mass	Designation
d	D	B	C	dyn. C _a N	stat. C _{0a} N	C _{ua} N	n _G grease min ⁻¹	n _G oil min ⁻¹	m ≈ kg	
30	55	32	16	15 300	36 000	3 250	11 000	16 000	0,29	234406-M-SP
35	62	34	17	18 900	47 000	4 250	9 500	14 000	0,38	234407-M-SP
40	68	36	18	22 900	59 000	5 300	8 500	12 000	0,463	234408-M-SP
45	75	38	19	25 000	67 000	6 000	7 500	10 000	0,579	234409-M-SP
50	80	38	19	26 000	72 000	6 500	7 000	9 500	0,629	234410-M-SP
55	90	44	22	36 500	99 000	8 900	6 300	8 500	0,944	234411-M-SP
60	95	44	22	36 000	98 000	8 900	6 000	8 000	1,01	234412-M-SP
65	100	44	22	38 500	111 000	10 000	5 600	7 500	1,08	234413-M-SP
70	110	48	24	46 000	134 000	12 100	5 300	7 000	1,49	234414-M-SP
75	115	48	24	47 500	144 000	12 900	5 000	6 700	1,57	234415-M-SP
80	125	54	27	56 000	175 000	15 500	4 500	6 000	2,16	234416-M-SP
85	130	54	27	57 000	181 000	15 600	4 500	6 000	2,25	234417-M-SP
90	140	60	30	66 000	213 000	17 700	4 000	5 300	2,92	234418-M-SP
95	145	60	30	66 000	219 000	17 900	4 000	5 300	3,04	234419-M-SP
100	150	60	30	67 000	226 000	18 100	3 800	5 000	3,17	234420-M-SP
105	160	66	33	74 000	250 000	19 500	3 600	4 800	4,07	234421-M-SP
110	170	72	36	98 000	325 000	24 400	3 400	4 500	5,19	234422-M-SP
120	180	72	36	101 000	345 000	25 000	3 200	4 300	5,56	234424-M-SP
130	200	84	42	128 000	440 000	30 500	2 800	3 800	8,28	234426-M-SP
140	210	84	42	132 000	470 000	31 500	2 600	3 600	8,78	234428-M-SP
150	225	90	45	142 000	520 000	34 000	2 600	3 600	10,8	234430-M-SP
160	240	96	48	168 000	600 000	38 000	2 400	3 400	12,9	234432-M-SP
170	260	108	54	207 000	740 000	45 500	2 200	3 200	17,7	234434-M-SP
180	280	120	60	235 000	840 000	49 500	2 000	3 000	23,4	234436-M-SP
190	290	120	60	244 000	900 000	52 000	1 900	2 800	24,7	234438-M-SP
200	310	132	66	285 000	1 060 000	59 000	1 800	2 600	31,5	234440-M-SP
220	340	144	72	340 000	1 330 000	71 000	1 600	2 200	41,7	234444-M-SP
240	360	144	72	350 000	1 420 000	73 000	1 500	2 000	43,8	234448-M-SP
260	400	164	82	400 000	1 680 000	83 000	1 400	1 900	64,5	234452-M-SP
280	420	164	82	415 000	1 790 000	86 000	1 300	1 800	69	234456-M-SP

medias ► <https://www.schaeffler.de/std/1D7B>



Dimensions							Mounting dimensions			
d	d ₁	B ₁	r	r ₁	d _s	n _s	d _a h12	D _a H12	r _a max.	r _{a1} max.
30	47	8	1	0,15	3,2	4,8	40,5	50,5	1	0,15
35	53	8,5	1	0,15	3,2	4,8	46,5	57	1	0,15
40	58,5	9	1	0,15	3,2	4,8	51,5	63,5	1	0,15
45	65	9,5	1	0,15	3,2	4,8	57,5	70	1	0,15
50	70	9,5	1	0,15	3,2	4,8	62,5	75	1	0,15
55	78	11	1,1	0,3	3,2	6,5	69	84,5	1,1	0,3
60	83	11	1,1	0,3	3,2	6,5	74	89,5	1,1	0,3
65	88	11	1,1	0,3	3,2	6,5	79	94,5	1,1	0,3
70	97	12	1,1	0,3	3,2	6,5	86,5	103,5	1,1	0,3
75	102	12	1,1	0,3	3,2	6,5	91,5	108,5	1,1	0,3
80	110	13,5	1,1	0,3	3,2	6,5	98,5	117	1,1	0,3
85	115	13,5	1,1	0,3	4,8	9,5	103,5	122	1,1	0,3
90	123	15	1,5	0,3	4,8	9,5	110,5	130,5	1,5	0,3
95	128	15	1,5	0,3	4,8	9,5	115,5	135,5	1,5	0,3
100	133	15	1,5	0,3	4,8	9,5	120,5	140,5	1,5	0,3
105	142	16,5	2	0,6	4,8	9,5	128	150	2	0,6
110	150	18	2	0,6	4,8	9,5	134,5	160	2	0,6
120	160	18	2	0,6	4,8	9,5	144,5	170	2	0,6
130	177	21	2	0,6	6,3	12,2	159	188	2	0,6
140	187	21	2,1	0,6	6,3	12,2	169	198	2,1	0,6
150	200	22,5	2,1	0,6	8	15	181	211,5	2,1	0,6
160	212	24	2,1	0,6	8	15	192,5	226	2,1	0,6
170	230	27	2,1	0,6	8	15	206,5	245	2,1	0,6
180	248	30	2,1	0,6	8	15	221	263	2,1	0,6
190	258	30	2,1	0,6	8	15	231	273	2,1	0,6
200	274	33	2,1	0,6	8	15	245	291,5	2,1	0,6
220	304	36	3	1,1	9,5	17,7	269	318	3	1
240	322	36	3	1,1	9,5	17,7	289	338	3	1
260	354	41	4	1,5	9,5	17,7	317,5	374,5	4	1,5
280	374	41	4	1,5	9,5	17,7	337,5	394,5	4	1,5





Super precision angular contact ball bearings BAX

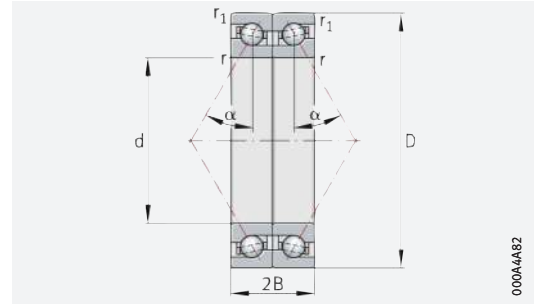

0004482

d = 50 – 110 mm

Main dimensions			Basic load ratings		Fatigue limit load C_{ua} N	Limiting speeds		Mass m ≈ kg	Designation
d	D	2B	dyn. C_a N	stat. C_{0a} N		n_G grease min^{-1}	n_G oil min^{-1}		
50	80	28,5	20 300	38 000	3 400	13 000	18 000	0,5	BAX50-F-T-P4S-DBL
	80	28,5	25 000	49 500	4 450	11 000	15 000	0,5	BAX50-H-T-P4S-DBL
55	90	33	24 200	46 000	4 150	11 000	16 000	0,74	BAX55-F-T-P4S-DBL
	90	33	30 000	61 000	5 400	9 500	14 000	0,74	BAX55-H-T-P4S-DBL
60	95	33	24 700	49 000	4 400	11 000	15 000	0,8	BAX60-F-T-P4S-DBL
	95	33	30 500	64 000	5 800	9 000	13 000	0,8	BAX60-H-T-P4S-DBL
65	100	33	26 000	54 000	4 850	10 000	14 000	0,84	BAX65-F-T-P4S-DBL
	100	33	32 000	70 000	6 300	8 500	12 000	0,84	BAX65-H-T-P4S-DBL
70	110	36	30 000	64 000	5 700	9 000	13 000	1,18	BAX70-F-T-P4S-DBL
	110	36	37 000	83 000	7 500	7 500	11 000	1,18	BAX70-H-T-P4S-DBL
75	115	36	30 500	67 000	6 000	8 500	12 000	1,24	BAX75-F-T-P4S-DBL
	115	36	37 500	87 000	7 800	7 500	10 000	1,24	BAX75-H-T-P4S-DBL
80	125	40,5	40 000	88 000	7 800	8 000	11 000	1,68	BAX80-F-T-P4S-DBL
	125	40,5	49 500	115 000	10 200	6 700	9 500	1,68	BAX80-H-T-P4S-DBL
85	130	40,5	41 000	92 000	8 000	7 500	11 000	1,98	BAX85-F-T-P4S-DBL
	130	40,5	50 000	120 000	10 400	6 300	9 000	1,98	BAX85-H-T-P4S-DBL
90	140	45	49 500	108 000	9 000	7 000	10 000	2,3	BAX90-F-T-P4S-DBL
	140	45	61 000	141 000	11 800	6 000	8 500	2,3	BAX90-H-T-P4S-DBL
95	145	45	51 000	113 000	9 300	6 700	9 500	2,4	BAX95-F-T-P4S-DBL
	145	45	62 000	147 000	12 100	5 600	8 000	2,4	BAX95-H-T-P4S-DBL
100	150	45	52 000	118 000	9 500	6 300	9 000	2,58	BAX100-F-T-P4S-DBL
	150	45	63 000	154 000	12 400	5 600	8 000	2,58	BAX100-H-T-P4S-DBL
105	160	49,5	52 000	124 000	9 700	6 000	8 500	3,2	BAX105-F-T-P4S-DBL
	160	49,5	64 000	162 000	12 600	5 300	7 500	3,2	BAX105-H-T-P4S-DBL
110	170	54	64 000	150 000	11 400	5 600	8 000	4,12	BAX110-F-T-P4S-DBL
	170	54	78 000	195 000	14 800	4 800	7 000	4,12	BAX110-H-T-P4S-DBL

medias ► <https://www.schaeffler.de/std/1D7C>

- 1) Light preload.
- 2) Moderate preload.

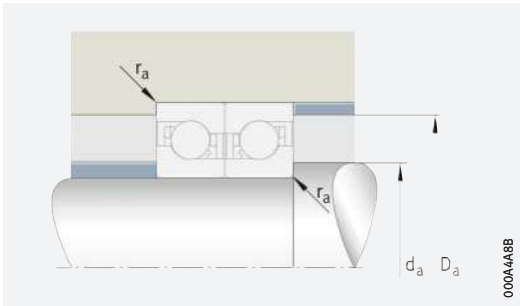

Mounting dimensions

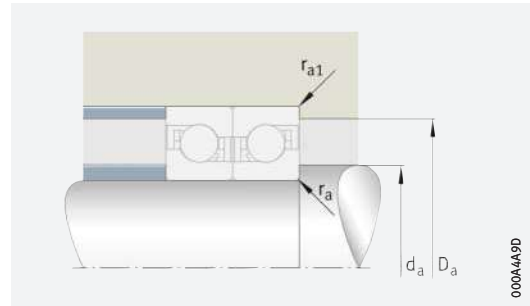

Mounting dimensions

Dimensions			Contact angle α °	Mounting dimensions				Preload force F_V		Lift-off force K_{aE}		Axial rigidity c_a	
d	r	r_1		d_a h12	D_a H12	r_a max.	r_{a1} max.	L ¹⁾ N	M ²⁾ N	L ¹⁾ N	M ²⁾ N	L ¹⁾ N/μm	M ²⁾ N/μm
	min.	min.											
50	0,6	0,6	30	57	73	0,6	0,6	84	416	240	1 214	123	216
	0,6	0,6	40	57	73	0,6	0,6	107	595	304	1 711	200	361
55	0,6	0,6	30	63,5	81,5	0,6	0,6	88	436	251	1 269	129	226
	0,6	0,6	40	63,5	81,5	0,6	0,6	144	741	410	2 131	229	401
60	0,6	0,6	30	68,5	86,5	0,6	0,6	110	517	315	1 508	143	247
	0,6	0,6	40	68,5	86,5	0,6	0,6	143	747	407	2 147	235	415
65	0,6	0,6	30	73,5	91,5	0,6	0,6	120	554	343	1 615	156	268
	0,6	0,6	40	73,5	91,5	0,6	0,6	155	792	441	2 276	256	448
70	0,6	0,6	30	80,5	99,5	0,6	0,6	149	661	426	1 928	173	293
	0,6	0,6	40	80,5	99,5	0,6	0,6	194	944	552	2 713	284	489
75	0,6	0,6	30	85,5	104,5	0,6	0,6	149	668	426	1 947	178	302
	0,6	0,6	40	85,5	104,5	0,6	0,6	194	955	552	2 744	292	504
80	0,6	0,6	30	91	113,5	0,6	0,6	217	903	621	2 633	206	342
	0,6	0,6	40	91	113,5	0,6	0,6	297	1 323	845	3 803	345	577
85	0,6	0,6	30	96	118,5	0,6	0,6	220	922	630	2 688	213	354
	0,6	0,6	40	96	118,5	0,6	0,6	297	1 332	845	3 828	354	594
90	0,6	0,6	30	102	128	0,6	0,6	300	1 181	860	3 447	234	381
	0,6	0,6	40	102	128	0,6	0,6	406	1 700	1 156	4 888	389	637
95	0,6	0,6	30	107	133	0,6	0,6	296	1 188	848	3 465	239	392
	0,6	0,6	40	107	133	0,6	0,6	400	1 711	1 139	4 918	398	657
100	0,6	0,6	30	112	138	0,6	0,6	299	1 206	856	3 516	247	404
	0,6	0,6	40	112	138	0,6	0,6	404	1 740	1 150	5 000	410	678
105	1	1	30	119,5	145,5	1	1	297	1 216	850	3 543	253	416
	1	1	40	119,5	145,5	1	1	396	1 737	1 127	4 989	418	695
110	1	1	30	125,5	154,5	1	1	380	1 495	1 088	4 357	278	451
	1	1	40	125,5	154,5	1	1	524	2 178	1 491	6 258	466	760





Super precision angular contact ball bearings BAX

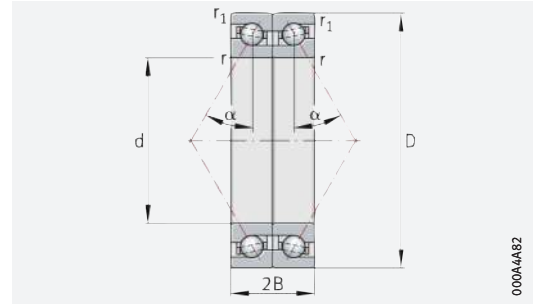

000A4482

d = 120 – 200 mm

Main dimensions			Basic load ratings		Fatigue limit load C_{ua} N	Limiting speeds		Mass m ≈ kg	Designation
d	D	2B	dyn. C_a N	stat. C_{0a} N		n_G grease min^{-1}	n_G oil min^{-1}		
120	180	54	66 000	163 000	12 000	5 300	7 500	4,42	BAX120-F-T-P4S-DBL
	180	54	81 000	212 000	15 600	4 500	6 300	4,42	BAX120-H-T-P4S-DBL
130	200	63	90 000	217 000	15 200	4 800	7 000	6,54	BAX130-F-T-P4S-DBL
	200	63	111 000	285 000	19 900	4 000	6 000	6,54	BAX130-H-T-P4S-DBL
140	210	63	94 000	237 000	16 100	4 500	6 700	6,96	BAX140-F-T-P4S-DBL
	210	63	115 000	310 000	21 000	3 800	5 600	6,96	BAX140-H-T-P4S-DBL
150	225	67,5	101 000	255 000	16 800	4 300	6 000	8,2	BAX150-F-T-P4S-DBL
	225	67,5	124 000	335 000	21 900	3 600	5 300	8,2	BAX150-H-T-P4S-DBL
160	240	72	111 000	290 000	18 400	4 000	5 600	10,6	BAX160-F-T-P4S-DBL
	240	72	136 000	380 000	24 000	3 400	4 800	10,6	BAX160-H-T-P4S-DBL
170	260	81	143 000	370 000	22 600	3 800	5 300	13,4	BAX170-F-T-P4S-DBL
	260	81	175 000	480 000	29 500	3 200	4 500	13,4	BAX170-H-T-P4S-DBL
180	280	90	177 000	450 000	26 500	3 400	5 000	17,8	BAX180-F-T-P4S-DBL
	280	90	218 000	590 000	35 000	3 000	4 300	17,8	BAX180-H-T-P4S-DBL
190	290	90	181 000	470 000	27 500	3 400	4 800	18,6	BAX190-F-T-P4S-DBL
	290	90	222 000	610 000	35 500	2 800	4 000	18,6	BAX190-H-T-P4S-DBL
200	310	99	183 000	495 000	28 000	3 200	4 500	24	BAX200-F-T-P4S-DBL
	310	99	225 000	640 000	36 000	2 600	3 800	24	BAX200-H-T-P4S-DBL

medias ► <https://www.schaeffler.de/std/1D7D>

- 1) Light preload.
- 2) Moderate preload.

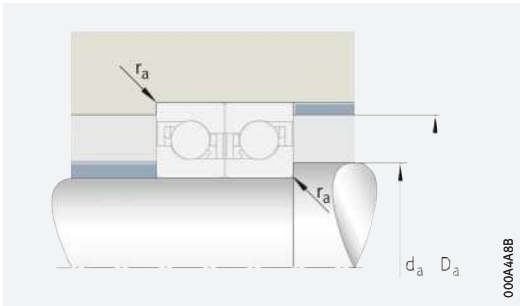

Mounting dimensions

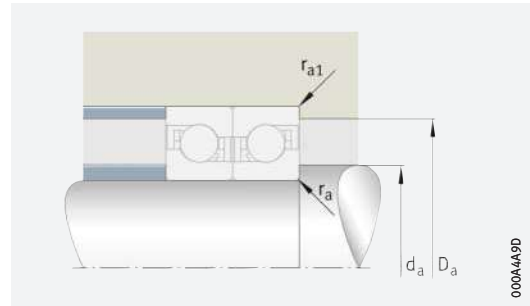

Mounting dimensions

Dimensions			Contact angle α	Mounting dimensions				Preload force F_V		Lift-off force K_{aE}		Axial rigidity c_a	
d	r	r_1		d_a h12	D_a H12	r_a max.	r_{a1} max.	L ¹⁾	M ²⁾	L ¹⁾	M ²⁾	L ¹⁾	M ²⁾
	min.	min.	°					N	N	N	N	N/ μ m	N/ μ m
120	1	1	30	135,5	164,5	1	1	392	1 554	1 122	4 525	296	481
	1	1	40	135,5	164,5	1	1	543	2 275	1 545	6 535	496	811
130	1	1	30	147,5	182,5	1	1	603	2 235	1 729	6 518	338	538
	1	1	40	147,5	182,5	1	1	850	3 280	2 421	9 429	570	907
140	1	1	30	157,5	192,5	1	1	621	2 317	1 779	6 752	360	573
	1	1	40	157,5	192,5	1	1	865	3 372	2 463	9 688	604	965
150	1,1	1,1	30	169	206	1,1	1,1	674	2 494	1 931	7 266	375	596
	1,1	1,1	40	169	206	1,1	1,1	938	3 623	2 670	10 408	630	1 003
160	1,1	1,1	30	180,5	219,5	1,1	1,1	752	2 764	2 154	8 049	405	641
	1,1	1,1	40	180,5	219,5	1,1	1,1	1 052	4 028	2 995	11 569	681	1 080
170	1,1	1,1	30	192,5	237,5	1,1	1,1	1 016	3 609	2 912	10 517	448	702
	1,1	1,1	40	192,5	237,5	1,1	1,1	1 447	5 305	4 121	15 244	758	1 185
180	1,1	1,1	30	204	255,5	1,1	1,1	1 329	4 610	3 811	13 438	498	775
	1,1	1,1	40	204	255,5	1,1	1,1	1 910	6 798	5 441	19 538	846	1 310
190	1,1	1,1	30	214	265,5	1,1	1,1	1 082	4 261	3 096	12 394	477	773
	1,1	1,1	40	214	265,5	1,1	1,1	1 503	6 245	4 276	17 927	801	1 306
200	1,1	1,1	30	229	280,5	1,1	1,1	1 089	4 312	3 116	12 537	490	796
	1,1	1,1	40	229	280,5	1,1	1,1	1 501	6 286	4 270	18 039	822	1 343







2 Bearings for screw drives

2.1 General features

Design variants

Bearings for screw drives are available as:

- axial angular contact ball bearings
 - double row, for screw mounting ► 1269 |  1
 - double row, not for screw mounting ► 1269 |  2
 - single row, for any combination ► 1269 |  3
 - angular contact ball bearing unit, for screw mounting ► 1269 |  4
 - double row or triple row, flange with flattened areas, for screw mounting ► 1270 |  5
- needle roller/axial cylindrical roller bearings
 - for screw mounting
 - not for screw mounting
- with accessories
 - seal carrier assembly
 - precision locknuts
 - sockets
 - free-of-charge calculation using BEARINX-online Easy Ballscrew.

Product catalogue



The standard range of these bearings is described in detail in Technical Product Information ►  TPI 123, Bearings for Screw Drives, and in our electronic product catalogue **medias professional**.

Downloading TPI 123

Technical Product Information TPI 123 is available from Schaeffler at ► <https://www.schaeffler.de/std/1D5A>.

medias

The following link will take you to the Schaeffler electronic product selection and information system: ► <https://medias.schaeffler.com>.

App for services

The app “PrecisionDesk” offers extensive services for rotary and linear bearings of a super precision design and assists fitters and engineers in the selection and mounting of bearings. Further information on PrecisionDesk ► 1374, download ► <https://www.schaeffler.de/std/1D59>.



Calculations on screw drive bearing arrangements can be carried out free of charge using BEARINX-online Easy Ballscrew.

2.2 Axial angular contact ball bearings

Bearing design

Precision bearings for screw drive bearing arrangements

Axial angular contact ball bearings are precision bearings for screw drive bearing arrangements. Depending on the series, they can support radial forces as well as axial forces in one or both directions. Contact seals protect the rolling element system against contamination and moisture. For higher speeds, non-contact minimal gap seals can be used.

With and without fixing holes

The bearings are available with and without fixing holes in the outer ring. Bearings with holes are screw mounted directly on the adjacent construction. This solution is particularly economical since there is then no need for the locating bore that would otherwise be required or for the bearing cover with the associated matching work.

Available with less stringent tolerances

For some areas of application, a bearing arrangement of lower precision is often sufficient. For this purpose, bearings with less stringent tolerances are available.

1

Axial angular contact ball bearings, double row, with fixing holes

- ① With lip seals or minimal gap seals ZKLF..-2RS, ZKLF..-2Z, ZKLF..-2RS-PE
- ② Matched pair ZKLF..-2RS-2AP

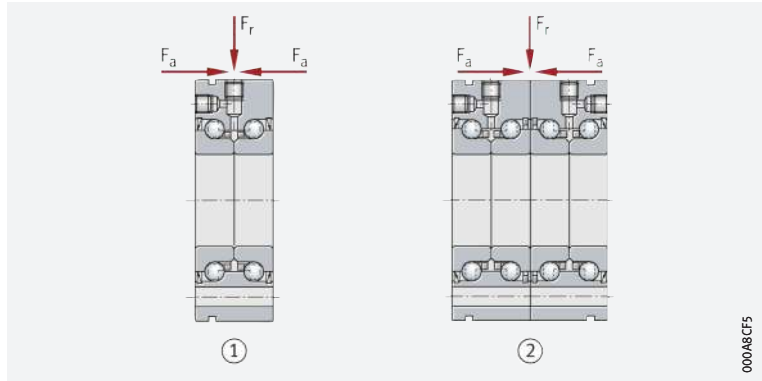

000A8CF5

2

Axial angular contact ball bearings, double row, without fixing holes

- ① With lip seals or minimal gap seals ZKLN..-2RS, ZKLN..-2Z, ZKLN..-2RS-PE
- ② Matched pair ZKLN..-2RS-2AP

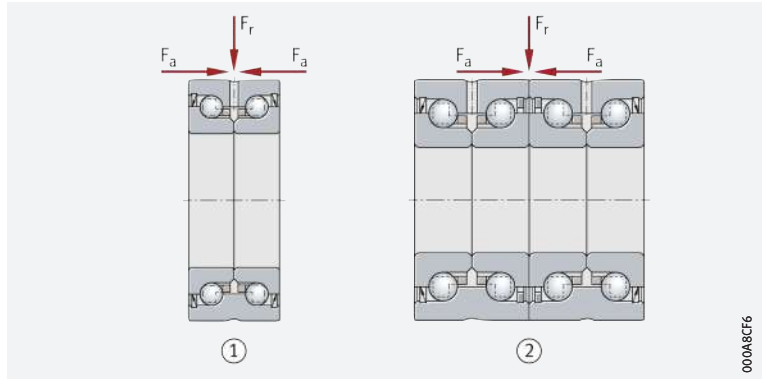

000A8CF6

3

Axial angular contact ball bearings, single row, for any combination

- ① Without seals 7602, 7603, BSB, BSB..-SU
- ② With seals 7602..-2RS, 7603..-2RS, BSB..-2RS, BSB..-2Z-SU

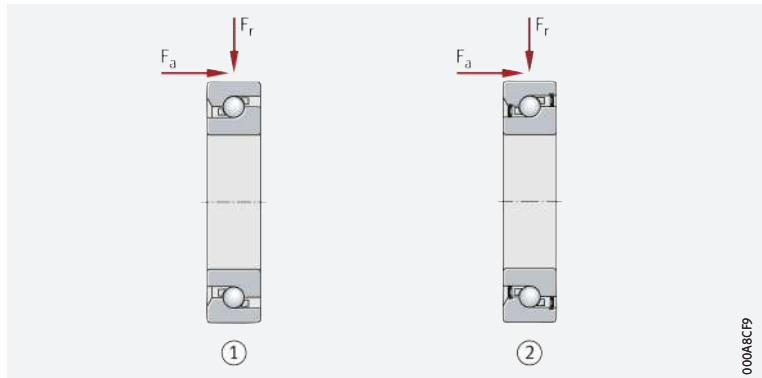

000A8CF9

4

Angular contact ball bearing unit, with fixing holes

Lip seals or gap seals ZKLR..-2RS, ZKLR..-2Z

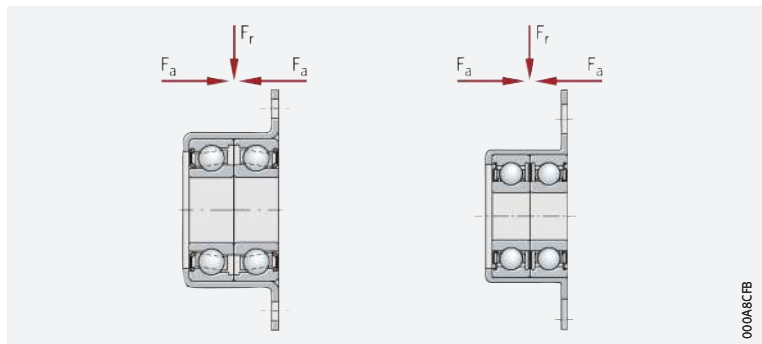

000A8CFB



Axial angular contact ball bearings, double or triple row, flange with flattened areas, with fixing holes

- ① Double row, lip seals or minimal gap seals ZKLFA..-2RS, ZKLFA..-2Z
- ② Triple row, lip seals DKLFA..-2RS

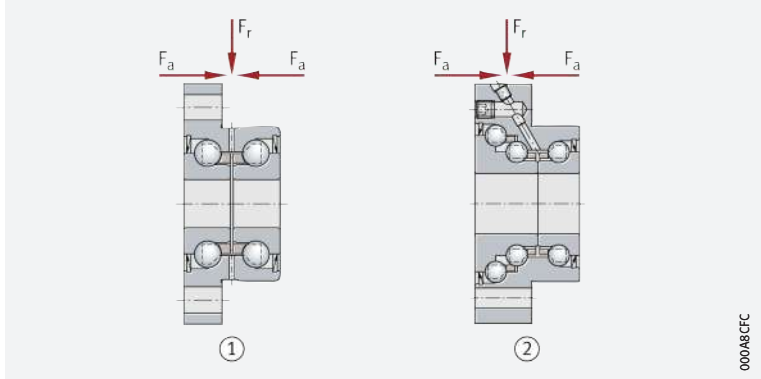

For special requirements

Screw drive bearing arrangements are subjected to requirements that often cannot be optimally fulfilled by the design construction of conventional bearings.

Wide product range

For the design of bearing arrangements that have high accuracy, high load carrying capacity, high rigidity, low friction, are easy to fit and maintenance-free or low-maintenance and are suitable for the highly dynamic operating conditions of threaded spindles, there is a wide range of INA and FAG axial angular contact ball bearings. With this product range, solutions can be found to all the technical and economic demands placed on the bearing arrangements of feed spindles [▶ 1276](#)

Single row and multiple row designs

Axial angular contact ball bearings are available as single, double or triple row ready-to-fit units. They are self-retaining and comprise thick-walled, geometrically stable outer rings, ball and cage assemblies and one-piece or two-piece inner rings. In several series, the outer ring has through holes for simple flange mounting of the bearing to the adjacent construction. The bearing rings are matched to each other such that a defined preload is achieved when the rings are clamped in place using a precision locknut.

Axial and radial load capacity

Due to the 60° contact angle, the bearings can support high axial forces as well as radial forces.

In X or O arrangement

In arrangements of multiple row angular contact ball bearings, a distinction is made between O, X and tandem arrangements in relation to the arrangement of contact angles. The arrangement of contact angles has an essential influence on the tilting rigidity of the bearing position.

The characteristics of the O arrangement are:

- high tilting rigidity
- higher critical whirling speed of the threaded spindle due to the high tilting rigidity of the bearing position
- longer rating life under additional radial loads due, for example, to a belt drive.

The characteristics of the X arrangement are:

- low tilting rigidity
- lower critical whirling speed of the threaded spindle
- shorter rating life under additional radial loads due, for example, to a belt drive.



X-life premium quality

Axial angular contact ball bearings ZKLF and ZKLN are supplied in the X-life design. As a result of increased raceway accuracy and raceway quality, there is a significant reduction in the stress conditions present on the rolling elements and raceways under the same load, compared to the standard bearings. The improved quality gives reduced friction in the bearing and lower bearing temperatures; running resistance is lower, less strain is placed on the lubricant and the grease operating life and, where applicable, necessary relubrication intervals are extended. As a result of the lower frictional energy, there is a simultaneous increase in the energy efficiency of the bearing arrangement.

Higher basic load ratings and limiting speeds with X-life

The basic dynamic load ratings C_a of axial angular contact ball bearings in the X-life design are 10% higher than those of the previous standard designs. This leads to a longer rating life L_{10} or can be used to allow higher loads on the bearing arrangement while achieving the same rating life. The lower bearing friction and associated reduction in heat generation in the bearing permit significantly higher limiting speeds $n_{G \text{ grease}}$.

Limiting values

Temperature range

The operating temperature of the bearings is limited by:

- the dimensional stability of the bearing rings and rolling elements
- the cage
- the lubricant
- the seals.

Possible operating temperatures of axial angular contact ball bearings ► 1271 | 1.

1
Permissible temperature range

Operating temperature	Axial angular contact ball bearings	
	from	to
	-30 °C	+120 °C



The operating temperature influences the dynamic bearing characteristics. The values given in the product tables are based on a room temperature of +20 °C.

Cages

The axial angular contact ball bearings have plastic cages. The cage design is not indicated in the suffix.

In axial angular contact ball bearings 7602, 7603 and BSB, the polyamide cages are indicated by the suffix TVP or T.

Suffixes

For a description of the suffixes used in this chapter ► 1271 | 2 and **medias** interchange ► <https://www.schaeffler.de/std/1D52>.

2
Suffixes and corresponding descriptions

Suffix	Description of suffix	Standard
PE	Bearing design with less stringent tolerances	
T, TVP	Polyamide cage	
2AP	Axial angular contact ball bearings, matched pair (ZKLN, ZKLF)	
2RS	Contact seal on both sides (lip seal)	
2Z	Minimal gap seal on both sides	
L055	Greased with high performance grease Arcanol MULTITOP	
SU	Universal bearing; single bearings can be used in sets in any combination required	
HC	Hybrid Ceramic, rings made from rolling bearing steel, balls made from ceramic	Special design, available by agreement



2.3 Needle roller/axial cylindrical roller bearings

Bearing design

- 🔗 *Double direction*
- 🔗 *With and without fixing holes*

These precision bearings are double direction axial cylindrical roller bearings with a radial bearing component.

The bearings are available with and without fixing holes in the outer ring. Bearings with holes are screw mounted directly on the adjacent construction. The large contact surface and the small pitch of the holes allow a connection to the adjacent construction that is extremely rigid and with low tendency to settling. There is therefore no need for the bearing cover that would otherwise be required to hold the bearing, and the matching work required.

If the axial abutment of the shaft locating washer is not sufficient or a seal raceway is required, bearings with a stepped shaft locating washer extended on one side are suitable.

 **6**
 Needle roller/axial cylindrical roller bearings, for screw mounting

- ① ZARF
- ② With stepped shaft locating washer extended on one side ZARF..-L

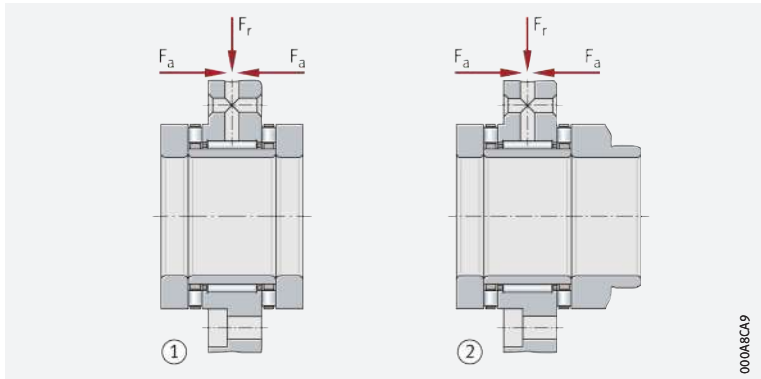

000A8CA9

 **7**
 Needle roller/axial cylindrical roller bearings, not for screw mounting

- ① ZARN
- ② With stepped shaft locating washer extended on one side ZARN..-L

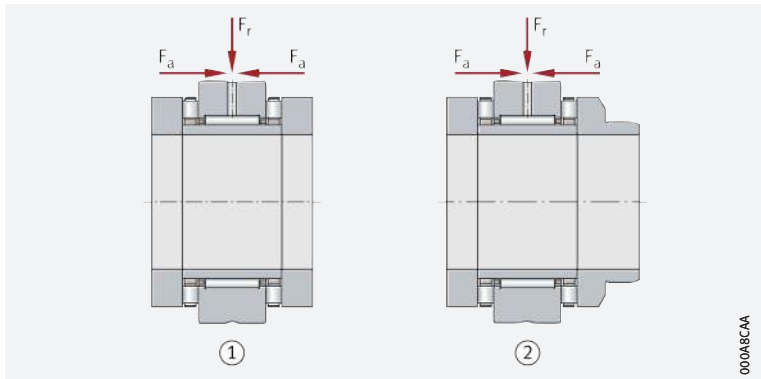

000A8CAA

🔗 Features

Needle roller/axial cylindrical roller bearings comprise an outer ring with radial and axial raceways, shaft locating washers, an inner ring, a radial needle roller and cage assembly and axial cylindrical roller and cage assemblies. The bearings are available with or without fixing holes.

🔗 Capable of supporting radial and axial loads

In addition to radial forces, the bearings can also support axial forces from both directions and tilting moments.

🔗 Preload and internal clearance

The outer ring, inner ring and axial cages are matched to each other such that the bearing is axially clearance-free after preloading by means of an INA precision locknut. The radial internal clearance corresponds to Group 2 in accordance with ISO 5753-1 (DIN 620-4).

☞ *Screw mounting of the outer ring: cover and matching work can be dispensed with*

Bearings for screw mounting

Needle roller/axial cylindrical roller bearings ZARF(-L) have holes in the outer ring. These are used for screw mounting directly on the adjacent construction or in a radial locating bore. Due to screw mounting of the outer ring, the cover that would otherwise be required and the matching work can therefore be dispensed with. The bearings are preloaded against the shaft shoulder by means of a locknut AM or ZM(A).

☞ *With seal carrier assembly*

In the interests of a simpler design, a seal carrier assembly DRS is recommended. The seal carrier assembly is centred on the outer ring and seals the bearing against external influences.

☞ *Mounting in the housing bore*

Bearings not for screw mounting

Bearings ZARN(-L) are mounted in the housing bore and the outer ring is located using a cover. They are preloaded against the shaft shoulder by means of a locknut AM or ZM(A).

☞ *With stepped shaft locating washer*

ZARN/F..-L has a stepped shaft locating washer extended on one side. These series are used in preference where the shaft locating washer is not adequately supported axially by the shaft shoulder or the bearing unit cannot be sealed on the outside surface of the normal shaft locating washer due to space conditions in the adjacent construction.

☞ *Heavy series*

ZARN/F(-L) is also available in a heavy series. This series has a larger cross-section for the same shaft diameter and therefore higher basic load ratings.

☞ *Limiting values*

Temperature range

The operating temperature of the bearings is limited by:

- the dimensional stability of the bearing rings and rolling elements
- the lubricant
- the seals.

Possible operating temperatures of needle roller/axial cylindrical roller bearings ► 1273 | 3.

3
Permissible temperature range

Operating temperature	Needle roller/axial cylindrical roller bearings	
	from	to
	-30 °C	+120 °C

Suffixes

For a description of the suffixes used in this chapter ► 1273 | 4 and **medias** interchange ► <https://www.schaeffler.de/std/1D52>.

4
Suffixes and corresponding descriptions



Suffix	Description of suffix	
L	Stepped shaft locating washer extended on one side	Standard
TVP	Axial bearing cages made from glass fibre reinforced polyamide PA66	



2.4 Accessories

Seal carrier assemblies

 *Complete sealing sets*

Seal carrier assemblies DRS are complete sealing sets  8 that are screw mounted on the outer ring of needle roller/axial cylindrical roller bearings ZARF(-L). They are precisely centred in this position and seal the bearings against external influences  9.

 8
Seal carrier assembly DRS

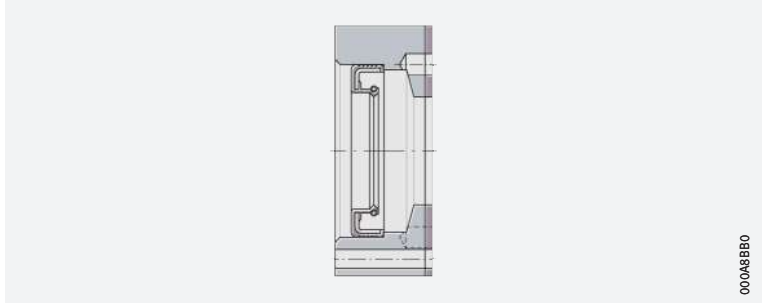

000488B0

 *Components of DRS*

The sealing elements are supplied as a complete set of individual parts and comprise:

- a seal flange
- a rotary shaft seal to DIN 3760, with an elastomer part made from NBR
- a gasket
- hexagonal socket head screws for fixing the carrier to the central washer of the bearing.

 9
Needle roller/axial cylindrical roller bearing ZARF..-L with seal carrier assembly

- ① Seal carrier assembly DRS
- ② Precision locknut ZM or ZMA
- ③ Rotary shaft seal to DIN 3760

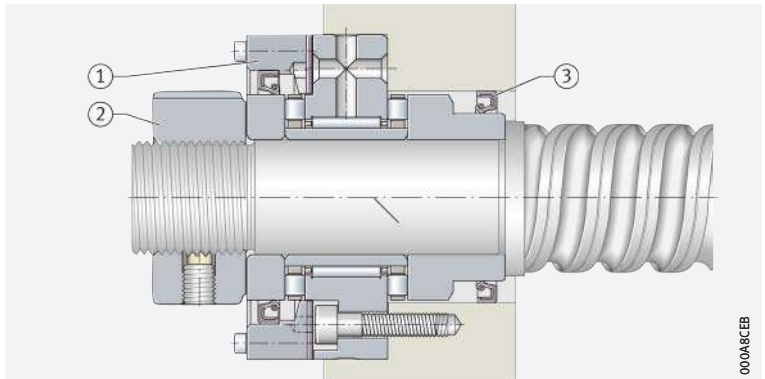

00048CEB

Precision locknuts are used in the axial preloading of bearings for screw drives

Precision locknuts

Precision locknuts are used to achieve a defined axial preload in bearings for screw drives. They are also used where high axial forces must be supported and high axial runout accuracy and rigidity are required.

10 Precision locknuts

- ① For axial clamping AM
- ② For radial clamping ZM or ZMA

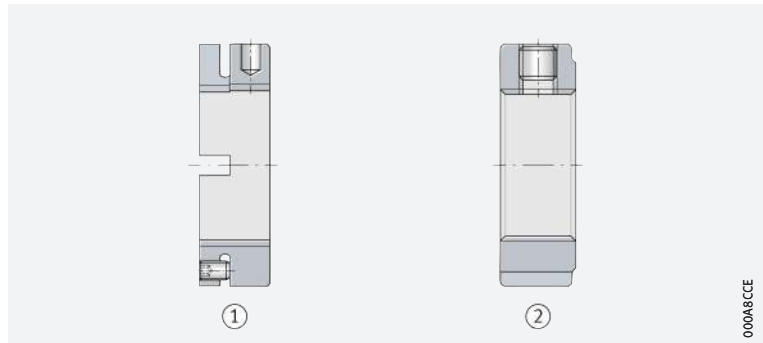

000ABCEE

Sockets

For simple tightening and loosening of precision locknuts ZM on shafts, the sockets LOCKNUT-SOCKET-KM ▶ 1275  11 are suitable. In combination with the socket AMS, this socket is also suitable for precision locknuts AM. They require less space on the circumference of the locknut than hook wrenches and allow the use of torque wrenches.

11 FAG sockets for precision locknuts ZM and sockets AMS

- ① Socket AMS
- ② Socket LOCKNUT-SOCKET-KM

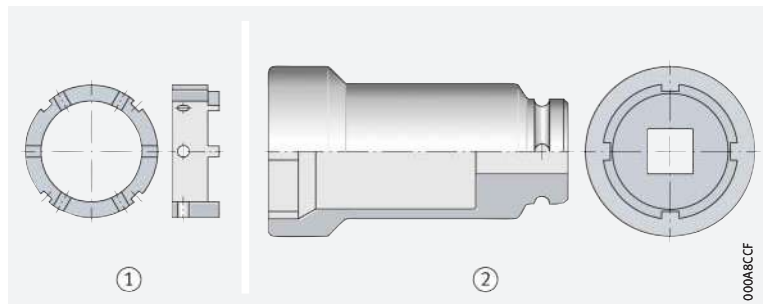

000ABCCF

Secure sockets using a locking pin and rubber washer

For increased reliability, FAG sockets should be secured using a locking pin and rubber washer. They therefore have a hole for the locking pin and a groove for the rubber washer. The locking pin and rubber washer are included in the scope of delivery.





Axial angular contact ball bearings

With fixing holes

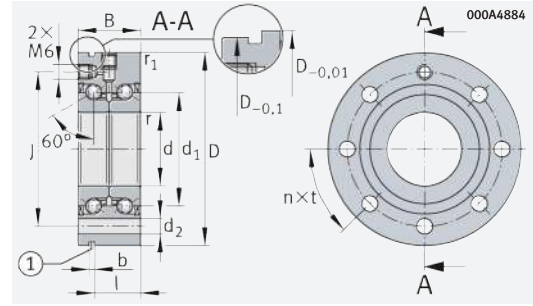

ZKLF..-2RS, ZKLF..-Z2 ($d \leq 50$ mm)

d = 12 – 20 mm

Main dimensions			Dimensions			Designation
d	D	B	d ₁	r min.	r ₁ min.	
12 0/-0,005	55 0/-0,010	25 0/-0,25	25	0,3	0,6	ZKLF1255-2RS-XL
0/-0,005	55 0/-0,010	25 0/-0,25	25	0,3	0,6	ZKLF1255-Z2-XL
15 0/-0,005	60 0/-0,010	25 0/-0,25	28	0,3	0,6	ZKLF1560-2RS-XL
0/-0,005	60 0/-0,010	25 0/-0,25	28	0,3	0,6	ZKLF1560-Z2-XL
17 0/-0,005	62 0/-0,010	25 0/-0,25	30	0,3	0,6	ZKLF1762-2RS-XL
0/-0,005	62 0/-0,010	25 0/-0,25	30	0,3	0,6	ZKLF1762-Z2-XL
20 0/-0,005	68 0/-0,010	28 0/-0,25	34,5	0,3	0,6	ZKLF2068-2RS-XL
0/-0,005	68 0/-0,010	28 0/-0,25	34,5	0,3	0,6	ZKLF2068-Z2-XL

d	Basic load ratings		Fatigue limit load C _{ua} N	Limiting speed n _{G grease} min ⁻¹	Thermally safe operating speed n _θ min ⁻¹	Bearing frictional torque M _R Nm	Mass m ≈ kg	Designation
	axial							
	dyn. C _a N	stat. C _{0a} N						
12	18 600	24 700	1 460	9 200	3 800	0,16	0,37	ZKLF1255-2RS-XL
	18 600	24 700	1 460	12 000	7 600	0,08	0,37	ZKLF1255-Z2-XL
15	19 600	28 000	1 650	8 200	3 500	0,2	0,43	ZKLF1560-2RS-XL
	19 600	28 000	1 650	10 800	7 000	0,1	0,43	ZKLF1560-Z2-XL
17	20 700	31 000	1 840	7 600	3 300	0,24	0,45	ZKLF1762-2RS-XL
	20 700	31 000	1 840	10 100	6 600	0,12	0,45	ZKLF1762-Z2-XL
20	28 500	47 000	2 750	6 600	3 000	0,3	0,61	ZKLF2068-2RS-XL
	28 500	47 000	2 750	8 700	5 400	0,15	0,61	ZKLF2068-Z2-XL

medias ► <https://www.schaeffler.de/std/1E49>

- ① Extraction slot. ② Adjacent construction, bearing screw mounted on flat surface.
 ③ Adjacent construction, bearing screw mounted in bore. ④ Only valid in assembled condition.

- Screws 10.9 not included in scope of delivery. Tightening torque according to manufacturer's data. Number of holes in adjacent construction corresponds to n_a.
- Based on rotating inner ring.
- The recommended INA precision locknuts are not included in the scope of delivery and must be ordered separately.
- The required axial locknut force must be observed when using other locknuts.
- Only valid in conjunction with INA precision locknuts. Observe the guidelines on locating/locating bearing arrangements ► TPI 123.

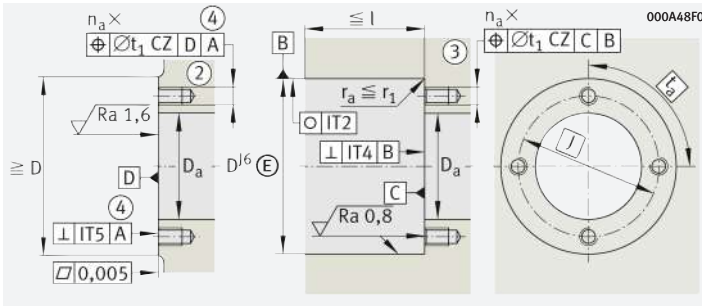

Housing design

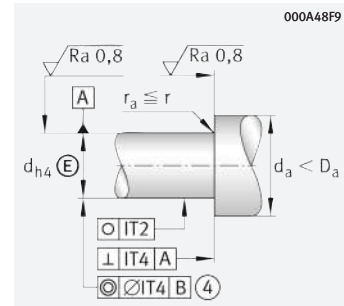

Shaft design
(threaded spindle)

Dimensions					Pitch		Mounting dimensions			Fixing screws ¹⁾ DIN EN ISO 4762		
d	J	d ₂	b	l	n	t _o	D _a max.	d _a min.	t ₁	Size	n _a	t _a o
12	42	6,8	3	17	3	120	33	16	0,1	M6	3	120
	42	6,8	3	17	3	120	33	16	0,1	M6	3	120
15	46	6,8	3	17	3	120	35	20	0,1	M6	3	120
	46	6,8	3	17	3	120	35	20	0,1	M6	3	120
17	48	6,8	3	17	6	60	37	23	0,1	M6	3	120
	48	6,8	3	17	6	60	37	23	0,1	M6	3	120
20	53	6,8	3	19	8	45	43	25	0,1	M6	4	90
	53	6,8	3	19	8	45	43	25	0,1	M6	4	90



d	Rigidity	Tilting rigidity	Mass moment of inertia ²⁾	Axial runout ²⁾	Recommended INA precision locknuts ³⁾			Required locknut force ⁴⁾
	axial				for radial clamping	for axial clamping	Tightening torque ⁵⁾	axial
	c _{aL}	c _{kL}	M _m	μm			M _A	N
	N/μm	Nm/mrad	kg · cm ²				Nm	
12	375	50	0,068	2	ZM12	–	8	5 307
	375	50	0,068	2	ZM12	–	8	5 307
15	400	65	0,102	2	ZM15	AM15	10	5 484
	400	65	0,102	2	ZM15	AM15	10	5 484
17	450	80	0,132	2	ZM17	AM17	15	7 514
	450	80	0,132	2	ZM17	AM17	15	7 514
20	650	140	0,273	2	ZM20	AM20	18	8 258
	650	140	0,273	2	ZM20	AM20	18	8 258

Axial angular contact ball bearings

With fixing holes

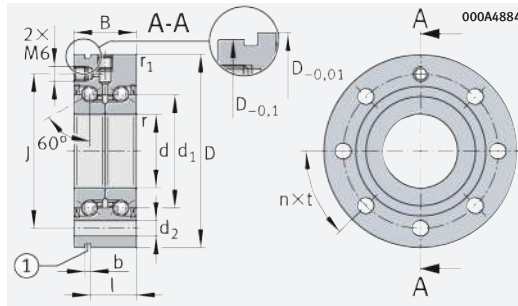

ZKLf.-2RS, ZKLf.-2Z ($d \leq 50$ mm)

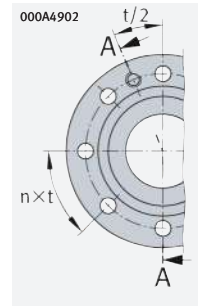

ZKLf30100

d = 25 – 35 mm

Main dimensions			Dimensions			Designation
d	D	B	d ₁	r min.	r ₁ min.	
25	75	28	40,5	0,3	0,6	ZKLf2575-2RS-XL
	75	28	40,5	0,3	0,6	ZKLf2575-2Z-XL
30	80	28	45,5	0,3	0,6	ZKLf3080-2RS-XL
	80	28	45,5	0,3	0,6	ZKLf3080-2Z-XL
	100	38	51	0,3	0,6	ZKLf30100-2RS-XL ²⁾
	100	38	51	0,3	0,6	ZKLf30100-2Z-XL ²⁾
35	90	34	52	0,3	0,6	ZKLf3590-2RS-XL
	90	34	52	0,3	0,6	ZKLf3590-2Z-XL

d	Basic load ratings		Fatigue limit load C _{ua} N	Limiting speed n _{G grease} min ⁻¹	Thermally safe operating speed n _θ min ⁻¹	Bearing frictional torque M _R Nm	Mass m ≈ kg	Designation
	axial dyn. C _a N	stat. C _{0a} N						
25	30 500	55 000	3 250	5 700	2 600	0,4	0,72	ZKLf2575-2RS-XL
	30 500	55 000	3 250	7 500	4 700	0,2	0,72	ZKLf2575-2Z-XL
30	32 000	64 000	3 750	5 000	2 200	0,5	0,78	ZKLf3080-2RS-XL
	32 000	64 000	3 750	6 700	4 300	0,25	0,78	ZKLf3080-2Z-XL
	65 000	108 000	6 400	4 500	2 100	0,8	1,63	ZKLf30100-2RS-XL ²⁾
	65 000	108 000	6 400	5 600	4 000	0,4	1,63	ZKLf30100-2Z-XL ²⁾
35	45 000	89 000	5 200	4 400	2 000	0,6	1,13	ZKLf3590-2RS-XL
	45 000	89 000	5 200	5 800	3 800	0,3	1,13	ZKLf3590-2Z-XL

medias ► <https://www.schaeffler.de/std/1E4A>

- ① Extraction slot. ② Adjacent construction, bearing screw mounted on flat surface.
- ③ Adjacent construction, bearing screw mounted in bore. ④ Only valid in assembled condition.

- 1) Screws 10.9 not included in scope of delivery. Tightening torque according to manufacturer's data. Number of holes in adjacent construction corresponds to n_a.
- 2) Heavy series.
- 3) Based on rotating inner ring.
- 4) The recommended INA precision locknuts are not included in the scope of delivery and must be ordered separately.
- 5) The required axial locknut force must be observed when using other locknuts.
- 6) Only valid in conjunction with INA precision locknuts. Observe the guidelines on locating/locating bearing arrangements ► [TPI 123](#).

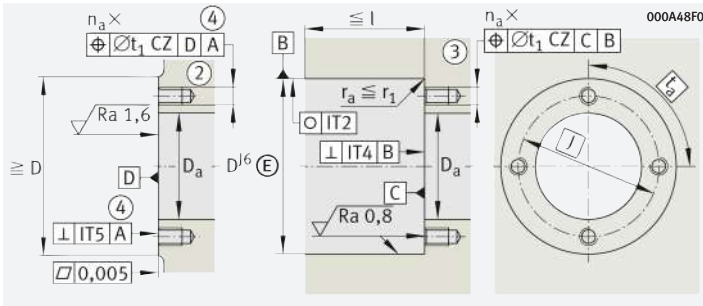

Housing design

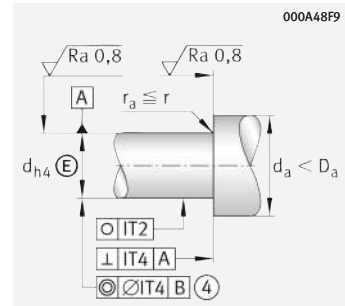

Shaft design
(threaded spindle)

Dimensions					Pitch		Mounting dimensions			Fixing screws ¹⁾ DIN EN ISO 4762		
d	J	d ₂	b	l	n	t °	D _a max.	d _a min.	t ₁	Size	n _a	t _a °
25	58	6,8	3	19	8	45	48	32	0,1	M6	4	90
	58	6,8	3	19	8	45	48	32	0,1	M6	4	90
30	63	6,8	3	19	12	30	53	40	0,1	M6	6	60
	63	6,8	3	19	12	30	53	40	0,1	M6	6	60
	80	8,8	3	30	8	45	64	47	0,2	M8	8	45
	80	8,8	3	30	8	45	64	47	0,2	M8	8	45
35	75	8,8	3	25	8	45	62	45	0,2	M8	4	90
	75	8,8	3	25	8	45	62	45	0,2	M8	4	90



d	Rigidity	Tilting rigidity	Mass moment of inertia ³⁾	Axial runout ³⁾	Recommended INA precision locknuts ⁴⁾			Required locknut force ⁵⁾
	axial				for radial clamping	for axial clamping	Tightening torque ⁶⁾	
	c _{aL}	c _{kL}	M _m		M _A	axial		
	N/μm	Nm/mrad	kg · cm ²	μm		Nm	N	
25	750	200	0,486	2	ZM25	AM25	25	9 123
	750	200	0,486	2	ZM25	AM25	25	9 123
30	850	300	0,73	2,5	ZM30	AM30	32	9 947
	850	300	0,73	2,5	ZM30	AM30	32	9 947
	950	400	1,91	2,5	ZMA30/52	AM30	65	19 509
	950	400	1,91	2,5	ZMA30/52	AM30	65	19 509
35	900	400	1,51	2,5	ZM35	AM35/58	40	10 770
	900	400	1,51	2,5	ZM35	AM35/58	40	10 770

Axial angular contact ball bearings

With fixing holes

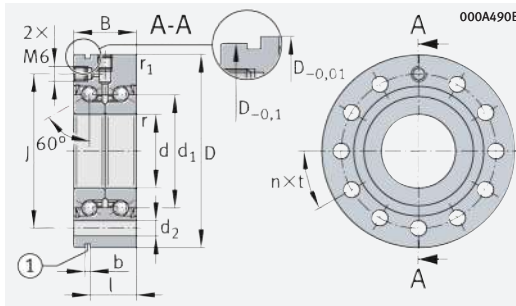

ZKLf.-2RS, ZKLf.-2Z ($d \leq 50$ mm)

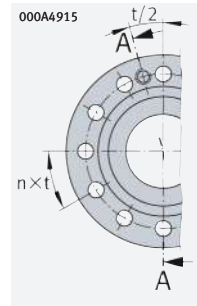

ZKLf40115
ZKLf50140

d = 40 – 50 mm

Main dimensions			Dimensions			Designation	
d	D	B	d ₁	r min.	r ₁ min.		
40	0/-0,005	100 0/-0,010	34 0/-0,25	58	0,3	0,6	ZKLf40100-2RS-XL
	0/-0,005	100 0/-0,010	34 0/-0,25	58	0,3	0,6	ZKLf40100-2Z-XL
	0/-0,005	115 0/-0,010	46 0/-0,25	65	0,6	0,6	ZKLf40115-2RS-XL ²⁾
	0/-0,005	115 0/-0,010	46 0/-0,25	65	0,6	0,6	ZKLf40115-2Z-XL ²⁾
50	0/-0,005	115 0/-0,010	34 0/-0,25	72	0,3	0,6	ZKLf50115-2RS-XL
	0/-0,005	115 0/-0,010	34 0/-0,25	72	0,3	0,6	ZKLf50115-2Z-XL
	0/-0,005	140 0/-0,010	54 0/-0,25	80	0,6	0,6	ZKLf50140-2RS-XL ²⁾
	0/-0,005	140 0/-0,010	54 0/-0,25	80	0,6	0,6	ZKLf50140-2Z-XL ²⁾

d	Basic load ratings		Fatigue limit load C _{ua} N	Limiting speed n _{G grease} min ⁻¹	Thermally safe operating speed n _θ min ⁻¹	Bearing frictional torque M _R Nm	Mass m ≈ kg	Designation
	axial dyn. C _a N	stat. C _{0a} N						
40	47 500	101 000	6 000	4 000	1 800	0,7	1,46	ZKLf40100-2RS-XL
	47 500	101 000	6 000	5 200	3 300	0,35	1,46	ZKLf40100-2Z-XL
	79 000	149 000	8 800	3 500	1 600	1,3	2,2	ZKLf40115-2RS-XL ²⁾
	79 000	149 000	8 800	4 400	3 100	0,65	2,2	ZKLf40115-2Z-XL ²⁾
50	51 000	126 000	7 400	3 200	1 500	0,9	1,86	ZKLf50115-2RS-XL
	51 000	126 000	7 400	4 200	3 000	0,45	1,86	ZKLf50115-2Z-XL
	125 000	250 000	14 800	2 900	1 200	2,6	4,7	ZKLf50140-2RS-XL ²⁾
	125 000	250 000	14 800	3 500	2 500	1,3	4,7	ZKLf50140-2Z-XL ²⁾

medias ► <https://www.schaeffler.de/std/1E4B>

- ① Extraction slot. ② Adjacent construction, bearing screw mounted on flat surface.
③ Adjacent construction, bearing screw mounted in bore. ④ Only valid in assembled condition.

- Screws 10.9 not included in scope of delivery. Tightening torque according to manufacturer's data. Number of holes in adjacent construction corresponds to n_a.
- Heavy series.
- Based on rotating inner ring.
- The recommended INA precision locknuts are not included in the scope of delivery and must be ordered separately.
- The required axial locknut force must be observed when using other locknuts.
- Only valid in conjunction with INA precision locknuts. Observe the guidelines on locating/locating bearing arrangements ► TPI 123.

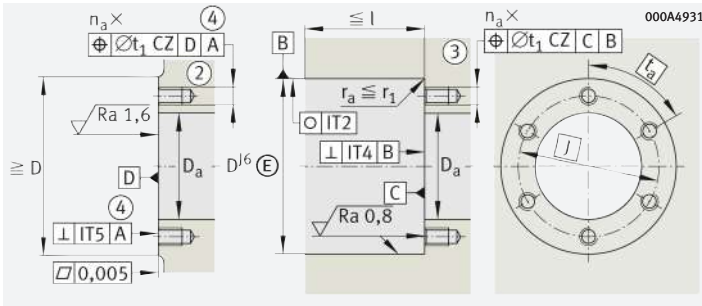

Housing design

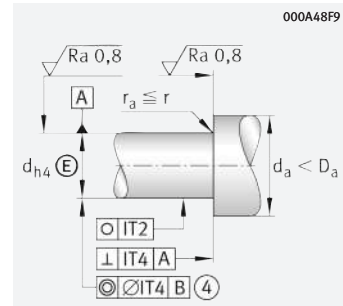

Shaft design
(threaded spindle)

Dimensions					Pitch		Mounting dimensions			Fixing screws ¹⁾ DIN EN ISO 4762		
d	J	d ₂	b	l	n	t _o	D _a max.	d _a min.	t ₁	Size	n _a	t _a o
40	80	8,8	3	25	8	45	67	50	0,2	M8	4	90
	80	8,8	3	25	8	45	67	50	0,2	M8	4	90
	94	8,8	3	36	12	30	80	56	0,2	M8	12	30
	94	8,8	3	36	12	30	80	56	0,2	M8	12	30
50	94	8,8	3	25	12	30	82	63	0,2	M8	6	60
	94	8,8	3	25	12	30	82	63	0,2	M8	6	60
	113	11	3	45	12	30	98	63	0,2	M10	12	30
	113	11	3	45	12	30	98	63	0,2	M10	12	30



d	Rigidity	Tilting rigidity	Mass moment of inertia ³⁾	Axial runout ³⁾	Recommended INA precision locknuts ⁴⁾			Required locknut force ⁵⁾
	axial				for radial clamping	for axial clamping	Tightening torque ⁶⁾	axial
	c _{aL}	c _{kL}	M _m	μm			M _A	N
	N/μm	Nm/mrad	kg · cm ²				Nm	
40	1 000	550	2,26	2,5	ZM40	AM40	55	13 412
	1 000	550	2,26	2,5	ZM40	AM40	55	13 412
	1 200	750	5,5	2,5	ZMA40/62	AM40	110	25 185
	1 200	750	5,5	2,5	ZMA40/62	AM40	110	25 815
50	1 250	1 000	5,24	2,5	ZM50	AM50	85	16 280
	1 250	1 000	5,24	2,5	ZM50	AM50	85	16 280
	1 400	1 500	15,2	2,5	ZMA50/75	AM50	150	28 451
	1 400	1 500	15,2	2,5	ZMA50/75	AM50	150	28 451



Axial angular contact ball bearings

With fixing holes

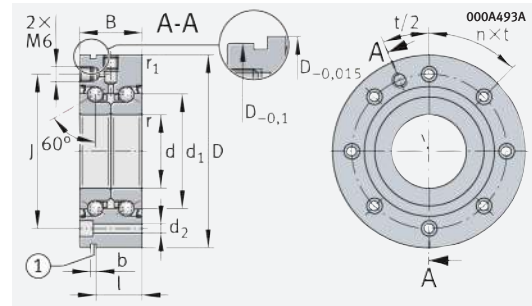

ZKLf..-2Z (60 mm ≤ d ≤ 100 mm)

d = 60 – 100 mm

Main dimensions			Dimensions			Designation
d	D	B	d ₁	r min.	r ₁ min.	
60 0/-0,008	145 0/-0,015	45 0/-0,25	85	0,6	0,6	ZKLf60145-2Z-XL
70 0/-0,008	155 0/-0,015	45 0/-0,25	95	0,6	0,6	ZKLf70155-2Z-XL
80 0/-0,008	165 0/-0,015	45 0/-0,25	105	0,6	0,6	ZKLf80165-2Z-XL
90 0/-0,008	190 0/-0,015	55 0/-0,25	120	0,6	0,6	ZKLf90190-2Z-XL
100 0/-0,008	200 0/-0,015	55 0/-0,25	132	0,6	0,6	ZKLf100200-2Z-XL
0/-0,008	230 0/-0,015	85 0/-0,25	146	0,6	0,6	ZKLf100230-2Z

d	Basic load ratings axial		Fatigue limit load C _{ua} N	Limiting speed n _{G grease} min ⁻¹	Thermally safe operating speed n _ø min ⁻¹	Bearing frictional torque M _R Nm	Mass m ≈ kg	Designation
	dyn. C _a N	stat. C _{0a} N						
60	93 000	214 000	12 600	4 000	3 000	1	4,3	ZKLf60145-2Z-XL
70	97 000	241 000	14 200	3 800	2 800	1,2	4,9	ZKLf70155-2Z-XL
80	100 000	265 000	15 400	3 600	2 700	1,4	5,3	ZKLf80165-2Z-XL
90	149 000	395 000	21 300	3 500	2 300	2,3	8,7	ZKLf90190-2Z-XL
100	154 000	435 000	22 400	3 300	2 150	2,6	9,3	ZKLf100200-2Z-XL
	295 000	790 000	29 000	2 900	2 000	3	17,6	ZKLf100230-2Z

medias ► <https://www.schaeffler.de/std/1E4C>

- ① Extraction slot. ② Adjacent construction, bearing screw mounted on flat surface.
- ③ Adjacent construction, bearing screw mounted in bore. ④ Only valid in assembled condition.

- 1) Screws 10.9 not included in scope of delivery. Tightening torque according to manufacturer's data. Number of holes in adjacent construction corresponds to n_a.
- 2) Based on rotating inner ring.
- 3) The recommended INA precision locknuts are not included in the scope of delivery and must be ordered separately.
- 4) The required axial locknut force must be observed when using other locknuts.
- 5) Only valid in conjunction with INA precision locknuts. Observe the guidelines on locating/locating bearing arrangements ► TPI 123.

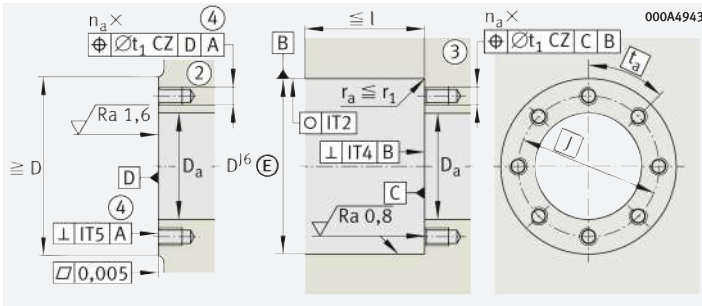

Housing design

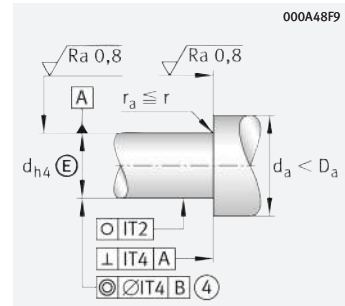

Shaft design
(threaded spindle)

Dimensions					Pitch		Mounting dimensions			Fixing screws ¹⁾ DIN EN ISO 4762		
d	J	d ₂	b	l	n	t ^o	D _a max.	d _a min.	t ₁	Size	n _a	t _a ^o
60	120	8,8	3	35	8	45	100	82	0,2	M8	8	45
70	130	8,8	3	35	8	45	110	92	0,2	M8	8	45
80	140	8,8	3	35	8	45	120	102	0,2	M8	8	45
90	165	11	3	45	8	45	138	116	0,2	M10	8	45
100	175	11	3	45	8	45	150	128	0,2	M10	8	45
	200	14	3	73	12	30	175	130	0,4	M12	12	30

d	Rigidity axial	Tilting rigidity	Mass moment of inertia ²⁾	Axial runout ²⁾	Recommended INA precision locknuts ³⁾			Required locknut force ⁴⁾
	c _{aL} N/μm	c _{kL} Nm/mrad	M _m kg · cm ²	μm	for radial clamping	for axial clamping	Tightening torque ⁵⁾ M _A Nm	axial N
60	1 300	1 650	13,7	3	ZMA60/98	AM60	100	16 700
70	1 450	2 250	19,8	3	ZMA70/110	AM70	130	19 031
80	1 600	3 000	27,6	3	ZMA80/120	AM80	160	20 604
90	1 700	4 400	59,9	3	ZMA90/130	AM90	200	22 731
100	1 900	5 800	85,3	3	ZMA100/140	AM100	250	25 624
	2 450	8 200	185	3	–	AM100	500	52 000



Axial angular contact ball bearings

With fixing holes
Less stringent tolerances

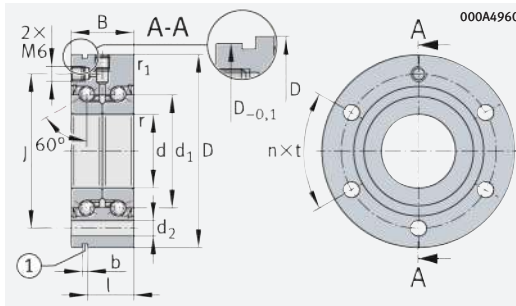

ZKL...-2RS-PE

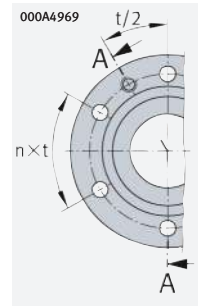

ZKL12, ZKL15

d = 12 – 50 mm

Main dimensions			Dimensions			Designation
d	D	B	d ₁	r min.	r ₁ min.	
12 0/-0,01	55 0/-0,013	25 0/-0,25	25	0,3	0,6	ZKL1255-2RS-PE
15 0/-0,01	60 0/-0,013	25 0/-0,25	28	0,3	0,6	ZKL1560-2RS-PE
17 0/-0,01	62 0/-0,013	25 0/-0,25	30	0,3	0,6	ZKL1762-2RS-PE
20 0/-0,01	68 0/-0,013	28 0/-0,25	34,5	0,3	0,6	ZKL2068-2RS-PE
25 0/-0,01	75 0/-0,013	28 0/-0,25	40,5	0,3	0,6	ZKL2575-2RS-PE
30 0/-0,01	80 0/-0,013	28 0/-0,25	45,5	0,3	0,6	ZKL3080-2RS-PE
35 0/-0,01	90 0/-0,015	34 0/-0,25	52	0,3	0,6	ZKL3590-2RS-PE
40 0/-0,01	100 0/-0,015	34 0/-0,25	58	0,3	0,6	ZKL40100-2RS-PE
50 0/-0,01	115 0/-0,015	34 0/-0,25	72	0,3	0,6	ZKL50115-2RS-PE

d	Basic load ratings		Fatigue limit load C _{ua} N	Limiting speed n _{G grease} min ⁻¹	Thermally safe operating speed n _θ min ⁻¹	Bearing frictional torque M _R Nm	Mass m ≈ kg	Designation
	axial dyn. C _a N	stat. C _{0a} N						
12	16 900	24 700	1 090	9 200	3 800	0,16	0,37	ZKL1255-2RS-PE
15	17 900	28 000	1 240	8 200	3 500	0,2	0,43	ZKL1560-2RS-PE
17	18 800	31 000	1 380	7 600	3 300	0,24	0,45	ZKL1762-2RS-PE
20	26 000	47 000	2 070	6 600	3 000	0,3	0,61	ZKL2068-2RS-PE
25	27 500	55 000	2 450	5 700	2 600	0,4	0,72	ZKL2575-2RS-PE
30	29 000	64 000	2 800	5 000	2 200	0,5	0,78	ZKL3080-2RS-PE
35	41 000	89 000	3 950	4 400	2 000	0,6	1,13	ZKL3590-2RS-PE
40	43 000	101 000	4 450	4 000	1 800	0,7	1,46	ZKL40100-2RS-PE
50	46 500	126 000	5 600	3 200	1 500	0,9	1,86	ZKL50115-2RS-PE

medias ► <https://www.schaeffler.de/std/1E4D>

- ① Extraction slot. ② Adjacent construction, bearing screw mounted on flat surface.
- ③ Adjacent construction, bearing screw mounted in bore. ④ Only valid in assembled condition.

- 1) Screws 10.9 not included in scope of delivery. Tightening torque according to manufacturer's data. Number of holes in adjacent construction corresponds to n_a.
- 2) Based on rotating inner ring.
- 3) The recommended INA precision locknuts are not included in the scope of delivery and must be ordered separately.
- 4) The required axial locknut force must be observed when using other locknuts.
- 5) Only valid in conjunction with INA precision locknuts. Observe the guidelines on locating/locating bearing arrangements ► TPI 123.

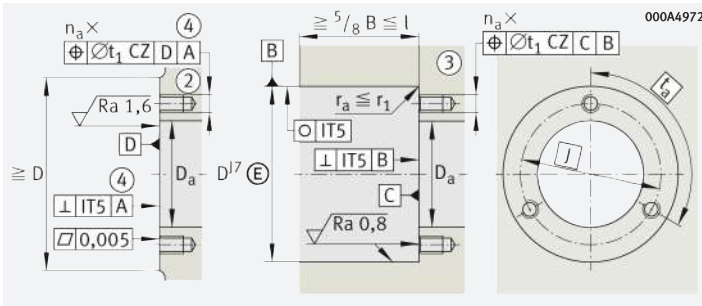

Housing design

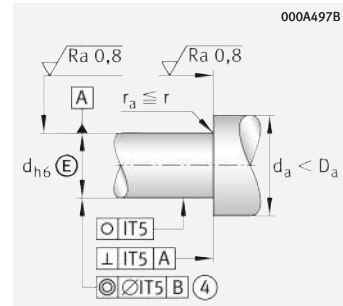

Shaft design
(threaded spindle)

Dimensions					Pitch		Mounting dimensions			Fixing screws ¹⁾ DIN EN ISO 4762		
d	J	d ₂	b	l	n	t ^o	D _a max.	d _a min.	t ₁	Size	n _a	t _a o
12	42	6,8	3	17	3	120	33	16	0,1	M6	3	120
15	46	6,8	3	17	3	120	35	20	0,1	M6	3	120
17	48	6,8	3	17	6	60	37	23	0,1	M6	3	120
20	53	6,8	3	19	8	45	43	25	0,1	M6	4	90
25	58	6,8	3	19	8	45	48	32	0,1	M6	4	90
30	63	6,8	3	19	12	30	53	40	0,1	M6	6	60
35	75	8,8	3	25	8	45	62	45	0,2	M8	4	90
40	80	8,8	3	25	8	45	67	50	0,2	M8	4	90
50	94	8,8	3	25	12	30	82	63	0,2	M8	6	60



d	Rigidity axial	Tilting rigidity	Mass moment of inertia ²⁾	Axial runout ²⁾	Recommended INA precision locknuts ³⁾			Required locknut force ⁴⁾
	c _{aL} N/μm	c _{kL} Nm/mrad	M _m kg · cm ²	μm	for radial clamping	for axial clamping	Tightening torque ⁵⁾ M _A Nm	axial N
12	375	50	0,068	5	ZM12	–	8	5 307
15	400	65	0,102	5	ZM15	AM15	10	5 484
17	450	80	0,132	5	ZM17	AM17	15	7 514
20	650	140	0,273	5	ZM20	AM20	18	8 258
25	750	200	0,486	5	ZM25	AM25	25	9 123
30	850	300	0,73	5	ZM30	AM30	32	9 947
35	900	400	1,51	5	ZM35	AM35/58	40	10 770
40	1 000	550	2,26	5	ZM40	AM40	55	13 412
50	1 250	1 000	5,24	5	ZM50	AM50	85	16 280

Axial angular contact ball bearings

With fixing holes
Matched pair

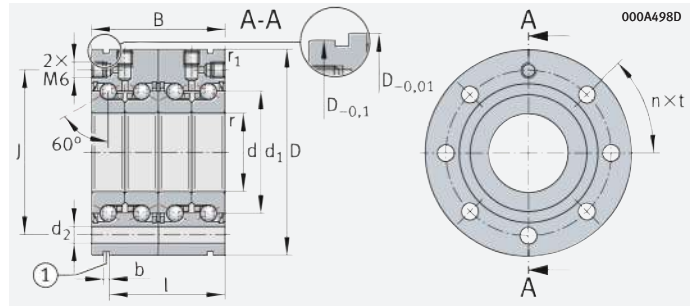

ZKLF.-2RS-2AP

d = 17 – 50 mm

Main dimensions			Dimensions			Designation
d	D	B	d ₁	r min.	r ₁ min.	
17	62	50	30	0,3	0,6	ZKLF1762-2RS-2AP-XL
20	68	56	34,5	0,3	0,6	ZKLF2068-2RS-2AP-XL
25	75	56	40,5	0,3	0,6	ZKLF2575-2RS-2AP-XL
30	80	56	45,5	0,3	0,6	ZKLF3080-2RS-2AP-XL
35	90	68	52	0,3	0,6	ZKLF3590-2RS-2AP-XL
40	100	68	58	0,3	0,6	ZKLF40100-2RS-2AP-XL
50	115	68	72	0,3	0,6	ZKLF50115-2RS-2AP-XL

d	Basic load ratings		Fatigue limit load C _{ua} N	Limiting speed n _{G grease} min ⁻¹	Thermally safe operating speed n _θ min ⁻¹	Bearing frictional torque M _R Nm	Mass m ≈ kg	Designation
	axial dyn. C _a N	stat. C _{0a} N						
17	33 500	62 000	3 700	7 600	3 300	0,36	0,9	ZKLF1762-2RS-2AP-XL
20	46 000	94 000	5 500	6 600	3 000	0,45	1,22	ZKLF2068-2RS-2AP-XL
25	49 000	111 000	6 500	5 700	2 600	0,6	1,44	ZKLF2575-2RS-2AP-XL
30	52 000	127 000	7 500	5 000	2 200	0,75	1,56	ZKLF3080-2RS-2AP-XL
35	73 000	177 000	10 500	4 400	2 000	0,9	2,26	ZKLF3590-2RS-2AP-XL
40	77 000	202 000	11 900	4 000	1 800	1,05	2,92	ZKLF40100-2RS-2AP-XL
50	83 000	250 000	14 900	3 200	1 500	1,35	3,72	ZKLF50115-2RS-2AP-XL

medias ► <https://www.schaeffler.de/std/1E4E>

- ① Extraction slot. ② Adjacent construction, bearing screw mounted on flat surface.
③ Adjacent construction, bearing screw mounted in bore. ④ Only valid in assembled condition.

- Screws 10.9 not included in scope of delivery. Tightening torque according to manufacturer's data. Number of holes in adjacent construction corresponds to n_a.
- Based on rotating inner ring.
- The recommended INA precision locknuts are not included in the scope of delivery and must be ordered separately.
- The required axial locknut force must be observed when using other locknuts.
- Only valid in conjunction with INA precision locknuts. Observe the guidelines on locating/locating bearing arrangements ► [□ TPI 123](#).

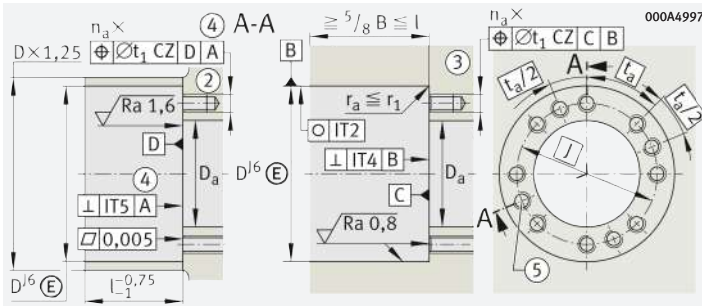

Housing design

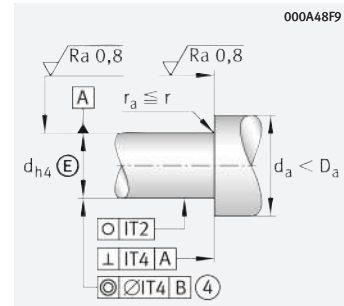

Shaft design
(threaded spindle)

Dimensions					Pitch		Mounting dimensions			Fixing screws ¹⁾ DIN EN ISO 4762		
d	J	d ₂	b	l	n	t ^o	D _a max.	d _a min.	t ₁	Size	n _a	t _a o
17	48	6,8	3	42	6	60	37	23	0,1	M6×60	6	60
20	53	6,8	3	47	8	45	43	25	0,1	M6×70	8	45
25	58	6,8	3	47	8	45	48	32	0,1	M6×70	8	45
30	63	6,8	3	47	12	30	53	40	0,1	M6×70	12	30
35	75	8,8	3	59	8	45	62	45	0,2	M8×80	8	45
40	80	8,8	3	59	8	45	67	50	0,2	M8×80	8	45
50	94	8,8	3	59	12	30	82	63	0,2	M8×80	12	30



d	Rigidity	Tilting rigidity	Mass moment of inertia ²⁾ M _m	Axial runout ²⁾ μm	Recommended INA precision locknuts ³⁾			Required locknut force ⁴⁾ axial N
	axial c _{aL} N/μm	c _{kL} Nm/mrad			for radial clamping	for axial clamping	Tightening torque ⁵⁾ M _A Nm	
17	800	200	0,264	2	ZM17	AM17	15	7 514
20	1 150	320	0,564	2	ZMA20/38	AM20	18	8 258
25	1 300	450	0,972	2	ZMA25/45	AM25	25	9 123
30	1 500	620	1,46	2,5	ZMA30/52	AM30	32	9 947
35	1 600	900	3,02	2,5	ZMA35/58	AM35/58	40	10 770
40	1 750	1 200	4,52	2,5	ZMA40/62	AM40	55	13 412
50	2 200	2 250	10,48	2,5	ZMA50/75	AM50	85	16 280



Axial angular contact ball bearings

Without fixing holes

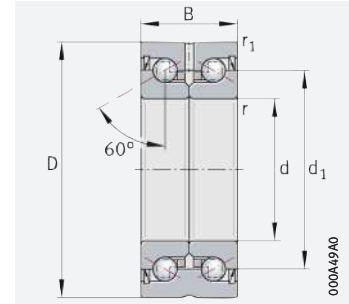

ZKLN...-2RS, ZKLN...-2Z

d = 6 – 12 mm

Main dimensions			Mass	Designation	
d	D	B	m ≈ kg		
6	+0,002 / -0,003	19 0 / -0,01	12 0 / -0,25	0,02	ZKLN0619-2Z-XL ⁵⁾
	+0,002 / -0,003	24 0 / -0,01	15 0 / -0,25	0,03	ZKLN0624-2RS-XL
	+0,002 / -0,003	24 0 / -0,01	15 0 / -0,25	0,03	ZKLN0624-2Z-XL
8	0 / -0,005	32 0 / -0,01	20 0 / -0,25	0,09	ZKLN0832-2RS-XL
	0 / -0,005	32 0 / -0,01	20 0 / -0,25	0,09	ZKLN0832-2Z-XL
10	0 / -0,005	34 0 / -0,01	20 0 / -0,25	0,1	ZKLN1034-2RS-XL
	0 / -0,005	34 0 / -0,01	20 0 / -0,25	0,1	ZKLN1034-2Z-XL
12	0 / -0,005	42 0 / -0,01	25 0 / -0,25	0,2	ZKLN1242-2RS-XL
	0 / -0,005	42 0 / -0,01	25 0 / -0,25	0,2	ZKLN1242-2Z-XL

d	Basic load ratings		Fatigue limit load C_{ua} N	Limiting speed n_G grease min ⁻¹	Thermally safe operating speed n_{θ} min ⁻¹	Bearing frictional torque M_R Nm	Designation
	axial dyn. C_a N	stat. C_{0a} N					
6	5 400	6 100	360	22 800	14 000	0,01	ZKLN0619-2Z-XL ⁵⁾
	7 600	8 500	500	16 400	6 800	0,04	ZKLN0624-2RS-XL
	7 600	8 500	500	19 900	12 000	0,02	ZKLN0624-2Z-XL
8	13 800	16 300	960	12 100	5 100	0,08	ZKLN0832-2RS-XL
	13 800	16 300	960	15 500	9 500	0,04	ZKLN0832-2Z-XL
10	14 700	18 800	1 110	10 900	4 600	0,12	ZKLN1034-2RS-XL
	14 700	18 800	1 110	14 400	8 600	0,06	ZKLN1034-2Z-XL
12	18 600	24 700	1 460	9 200	3 800	0,16	ZKLN1242-2RS-XL
	18 600	24 700	1 460	12 000	7 600	0,08	ZKLN1242-2Z-XL

medias ► <https://www.schaeffler.de/std/1E4F>

④ Only valid in assembled condition.

- 1) Based on rotating inner ring.
- 2) The recommended INA precision locknuts are not included in the scope of delivery and must be ordered separately.
- 3) The required axial locknut force must be observed when using other locknuts.
- 4) Only valid in conjunction with INA precision locknuts.
Observe the guidelines on locating/locating bearing arrangements ► □ TPI 123.
- 5) No relubrication facility.

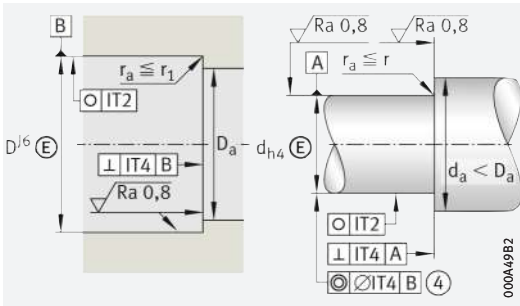

Design of housing and shaft (threaded spindle)

d	Mass moment of inertia ¹⁾ M_m kg · cm ²	Axial runout ¹⁾ μm	Dimensions			Mounting dimensions	
			d_1	r min.	r_1 min.	D_a max.	d_a min.
6	0,0019	2	12	0,3	0,3	16	9
	0,0044	2	14	0,3	0,6	19	9
	0,0044	2	14	0,3	0,6	19	9
8	0,02	2	19	0,3	0,6	26	11
	0,02	2	19	0,3	0,6	26	11
10	0,029	2	21	0,3	0,6	28	14
	0,029	2	21	0,3	0,6	28	14
12	0,068	2	25	0,3	0,6	33	16
	0,068	2	25	0,3	0,6	33	16



d	Rigidity	Tilting rigidity c_{kL} Nm/mrad	Recommended INA precision locknuts ²⁾			Required locknut force ³⁾ axial N
	axial c_{aL} N/ μm		for radial clamping	for axial clamping	Tightening torque ⁴⁾ M_A Nm	
6	150	4	ZM06	–	1	2 010
	200	8	ZM06	–	2	2 404
	200	8	ZM06	–	2	2 404
8	250	20	ZM08	–	4	3 468
	250	20	ZM08	–	4	3 468
10	325	25	ZM10	–	6	4 891
	325	25	ZM10	–	6	4 891
12	375	50	ZM12	–	8	5 307
	375	50	ZM12	–	8	5 307



Axial angular contact ball bearings

Without fixing holes

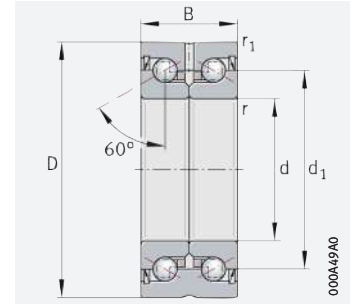

ZKLN...-2RS, ZKLN...-2Z

d = 15 – 25 mm

Main dimensions			Mass	Designation
d	D	B	m ≈ kg	
15 0/-0,005	45 0/-0,01	25 0/-0,25	0,21	ZKLN1545-2RS-XL
0/-0,005	45 0/-0,01	25 0/-0,25	0,21	ZKLN1545-2Z-XL
17 0/-0,005	47 0/-0,01	25 0/-0,25	0,22	ZKLN1747-2RS-XL
0/-0,005	47 0/-0,01	25 0/-0,25	0,22	ZKLN1747-2Z-XL
20 0/-0,005	52 0/-0,01	28 0/-0,25	0,31	ZKLN2052-2RS-XL
0/-0,005	52 0/-0,01	28 0/-0,25	0,31	ZKLN2052-2Z-XL
25 0/-0,005	57 0/-0,01	28 0/-0,25	0,34	ZKLN2557-2RS-XL
0/-0,005	57 0/-0,01	28 0/-0,25	0,34	ZKLN2557-2Z-XL

d	Basic load ratings		Fatigue limit load C_{ua} N	Limiting speed n_G grease min^{-1}	Thermally safe operating speed n_{θ} min^{-1}	Bearing frictional torque M_R Nm	Designation
	axial dyn. C_a N	stat. C_{0a} N					
15	19 600	28 000	1 650	8 200	3 500	0,2	ZKLN1545-2RS-XL
	19 600	28 000	1 650	10 800	7 000	0,1	ZKLN1545-2Z-XL
17	20 700	31 000	1 840	7 600	3 300	0,24	ZKLN1747-2RS-XL
	20 700	31 000	1 840	10 100	6 600	0,12	ZKLN1747-2Z-XL
20	28 500	47 000	2 750	6 600	3 000	0,3	ZKLN2052-2RS-XL
	28 500	47 000	2 750	8 700	5 400	0,15	ZKLN2052-2Z-XL
25	30 500	55 000	3 250	5 700	2 600	0,4	ZKLN2557-2RS-XL
	30 500	55 000	3 250	7 500	4 700	0,2	ZKLN2557-2Z-XL

medias ► <https://www.schaeffler.de/std/1E50>

④ Only valid in assembled condition.

- 1) Based on rotating inner ring.
- 2) The recommended INA precision locknuts are not included in the scope of delivery and must be ordered separately.
- 3) The required axial locknut force must be observed when using other locknuts.
- 4) Only valid in conjunction with INA precision locknuts.
Observe the guidelines on locating/locating bearing arrangements ► TPI 123.

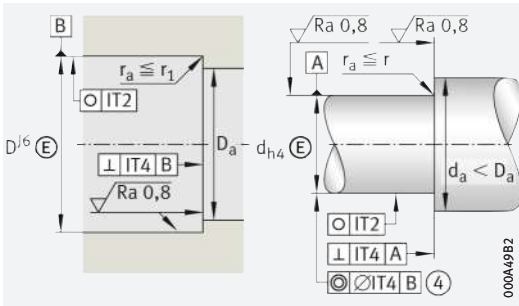

Design of housing and shaft (threaded spindle)

d	Mass moment of inertia ¹⁾ M_m kg · cm ²	Axial runout ¹⁾ μm	Dimensions			Mounting dimensions	
			d_1	r min.	r_1 min.	D_a max.	d_a min.
15	0,102	2	28	0,3	0,6	35	20
	0,102	2	28	0,3	0,6	35	20
17	0,132	2	30	0,3	0,6	37	23
	0,132	2	30	0,3	0,6	37	23
20	0,273	2	34,5	0,3	0,6	43	25
	0,273	2	34,5	0,3	0,6	43	25
25	0,486	2	40,5	0,3	0,6	48	32
	0,486	2	40,5	0,3	0,6	48	32



d	Rigidity axial c_{aL} N/μm	Tilting rigidity c_{kL} Nm/mrad	Recommended INA precision locknuts ²⁾			Required locknut force ³⁾ axial N
			for radial clamping	for axial clamping	Tightening torque ⁴⁾ M_A Nm	
15	400	65	ZM15	AM15	10	5 484
	400	65	ZM15	AM15	10	5 484
17	450	80	ZM17	AM17	15	7 514
	450	80	ZM17	AM17	15	7 514
20	650	140	ZM20	AM20	18	8 258
	650	140	ZM20	AM20	18	8 258
25	750	200	ZM25	AM25	25	9 123
	750	200	ZM25	AM25	25	9 123



Axial angular contact ball bearings

Without fixing holes

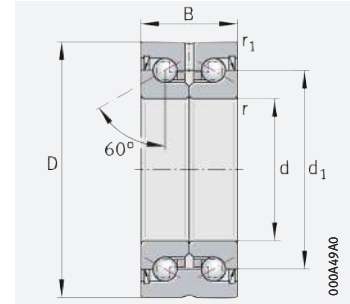

ZKLN...-2RS, ZKLN...-2Z

d = 30 – 40 mm

Main dimensions			Mass	Designation	
d	D	B	m ≈ kg		
30	0/-0,005	62 0/-0,01	28 0/-0,25	0,39	ZKLN3062-2RS-XL
	0/-0,005	62 0/-0,01	28 0/-0,25	0,39	ZKLN3062-2Z-XL
	0/-0,005	72 0/-0,01	38 0/-0,25	0,72	ZKLN3072-2RS-XL⁵⁾
	0/-0,005	72 0/-0,01	38 0/-0,25	0,72	ZKLN3072-2Z-XL⁵⁾
35	0/-0,005	72 0/-0,01	34 0/-0,25	0,51	ZKLN3572-2RS-XL
	0/-0,005	72 0/-0,01	34 0/-0,25	0,51	ZKLN3572-2Z-XL
40	0/-0,005	75 0/-0,01	34 0/-0,25	0,61	ZKLN4075-2RS-XL
	0/-0,005	75 0/-0,01	34 0/-0,25	0,61	ZKLN4075-2Z-XL
	0/-0,005	90 0/-0,01	46 0/-0,25	0,95	ZKLN4090-2RS-XL⁵⁾
	0/-0,005	90 0/-0,01	46 0/-0,25	0,95	ZKLN4090-2Z-XL⁵⁾

d	Basic load ratings		Fatigue limit load C_{ua} N	Limiting speed n_G grease min^{-1}	Thermally safe operating speed n_{θ} min^{-1}	Bearing frictional torque M_R Nm	Designation
	dyn. C_a N	stat. C_{0a} N					
30	32 000	64 000	3 750	5 000	2 200	0,5	ZKLN3062-2RS-XL
	32 000	64 000	3 750	6 700	4 300	0,25	ZKLN3062-2Z-XL
	65 000	108 000	6 400	4 500	2 100	0,8	ZKLN3072-2RS-XL⁵⁾
	65 000	108 000	6 400	5 600	4 000	0,4	ZKLN3072-2Z-XL⁵⁾
35	45 000	89 000	5 200	4 400	2 000	0,6	ZKLN3572-2RS-XL
	45 000	89 000	5 200	5 800	3 800	0,3	ZKLN3572-2Z-XL
40	47 500	101 000	6 000	4 000	1 800	0,7	ZKLN4075-2RS-XL
	47 500	101 000	6 000	5 200	3 300	0,35	ZKLN4075-2Z-XL
	79 000	149 000	8 800	3 500	1 600	1,3	ZKLN4090-2RS-XL⁵⁾
	79 000	149 000	8 800	4 400	3 100	0,65	ZKLN4090-2Z-XL⁵⁾

medias ► <https://www.schaeffler.de/std/1E51>

④ Only valid in assembled condition.

- 1) Based on rotating inner ring.
- 2) The recommended INA precision locknuts are not included in the scope of delivery and must be ordered separately.
- 3) The required axial locknut force must be observed when using other locknuts.
- 4) Only valid in conjunction with INA precision locknuts.
Observe the guidelines on locating/locating bearing arrangements ► TPI 123.
- 5) Heavy series.

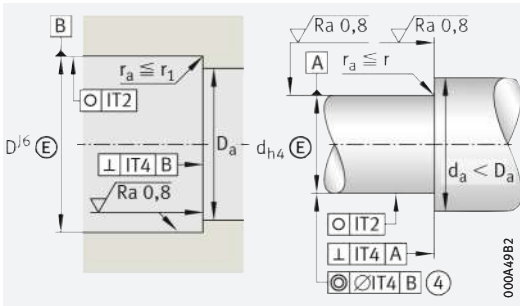

Design of housing and shaft (threaded spindle)

d	Mass moment of inertia ¹⁾ M_m kg · cm ²	Axial runout ¹⁾ μm	Dimensions			Mounting dimensions	
			d_1	r min.	r_1 min.	D_a max.	d_a min.
30	0,73	2,5	45,5	0,3	0,6	53	40
	0,73	2,5	45,5	0,3	0,6	53	40
	1,91	2,5	51	0,3	0,6	64	47
	1,91	2,5	51	0,3	0,6	64	47
35	1,51	2,5	52	0,3	0,6	62	45
	1,51	2,5	52	0,3	0,6	62	45
40	2,26	2,5	58	0,3	0,6	67	50
	2,26	2,5	58	0,3	0,6	67	50
	5,5	2,5	65	0,6	0,6	80	56
	5,5	2,5	65	0,6	0,6	80	56



d	Rigidity axial c_{aL} N/ μm	Tilting rigidity c_{kL} Nm/mrad	Recommended INA precision locknuts ²⁾			Required locknut force ³⁾ axial N
			for radial clamping	for axial clamping	Tightening torque ⁴⁾ M_A Nm	
30	850	300	ZM30	AM30	32	9 947
	850	300	ZM30	AM30	32	9 947
	950	400	ZMA30/52	AM30	65	19 509
	950	400	ZMA30/52	AM30	65	19 509
35	900	400	ZM35	AM35/58	40	10 770
	900	400	ZM35	AM35/58	40	10 770
40	1 000	550	ZM40	AM40	55	13 412
	1 000	550	ZM40	AM40	55	13 412
	1 200	750	ZMA40/62	AM40	110	25 185
	1 200	750	ZMA40/62	AM40	110	25 185



Axial angular contact ball bearings

Without fixing holes

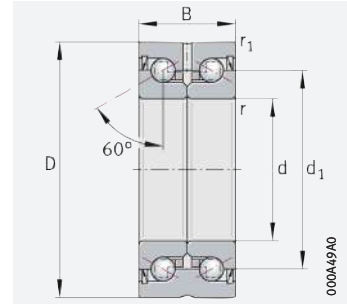

ZKLN...-2RS, ZKLN...-2Z

d = 50 – 100 mm

Main dimensions			Mass	Designation
d	D	B	m ≈ kg	
50 0/-0,005	110 0/-0,01	54 0/-0,25	2,5	ZKLN50110-2RS-XL ⁵⁾
	110 0/-0,01	54 0/-0,25	2,5	ZKLN50110-2Z-XL ⁵⁾
	90 0/-0,01	34 0/-0,25	0,88	ZKLN5090-2RS-XL
	90 0/-0,01	34 0/-0,25	0,88	ZKLN5090-2Z-XL
60 0/-0,008	110 0/-0,015	45 0/-0,25	2,2	ZKLN60110-2Z-XL
70 0/-0,008	120 0/-0,015	45 0/-0,25	2,4	ZKLN70120-2Z-XL
80 0/-0,008	130 0/-0,015	45 0/-0,25	2,7	ZKLN80130-2Z-XL
90 0/-0,008	150 0/-0,015	55 0/-0,25	4,5	ZKLN90150-2Z-XL
100 0/-0,008	160 0/-0,015	55 0/-0,25	4,9	ZKLN100160-2Z-XL

d	Basic load ratings		Fatigue limit load C_{ua} N	Limiting speed n_G grease min^{-1}	Thermally safe operating speed n_{θ} min^{-1}	Bearing frictional torque M_R Nm	Designation
	axial dyn. C_a N	stat. C_{0a} N					
50	125 000	250 000	14 800	2 900	1 200	2,6	ZKLN50110-2RS-XL ⁵⁾
	125 000	250 000	14 800	3 500	2 500	1,3	ZKLN50110-2Z-XL ⁵⁾
	51 000	126 000	7 400	3 200	1 500	0,9	ZKLN5090-2RS-XL
	51 000	126 000	7 400	4 200	3 000	0,45	ZKLN5090-2Z-XL
60	93 000	214 000	12 600	4 000	3 000	1	ZKLN60110-2Z-XL
70	97 000	241 000	14 200	3 800	2 800	1,2	ZKLN70120-2Z-XL
80	100 000	265 000	15 400	3 600	2 700	1,4	ZKLN80130-2Z-XL
90	149 000	395 000	21 300	3 500	2 300	2,3	ZKLN90150-2Z-XL
100	154 000	435 000	22 400	3 300	2 150	2,6	ZKLN100160-2Z-XL

medias ► <https://www.schaeffler.de/std/1E52>

④ Only valid in assembled condition.

- 1) Based on rotating inner ring.
- 2) The recommended INA precision locknuts are not included in the scope of delivery and must be ordered separately.
- 3) The required axial locknut force must be observed when using other locknuts.
- 4) Only valid in conjunction with INA precision locknuts.
Observe the guidelines on locating/locating bearing arrangements ► □ TPI 123.
- 5) Heavy series.

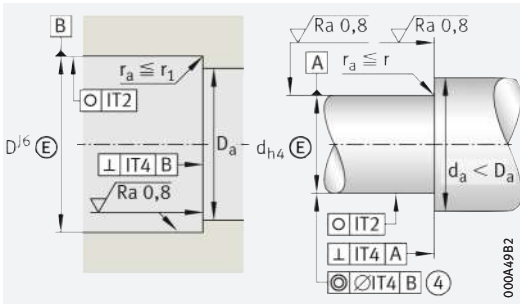

Design of housing and shaft (threaded spindle)

d	Mass moment of inertia ¹⁾ M _m kg · cm ²	Axial runout ¹⁾ μm	Dimensions			Mounting dimensions	
			d ₁	r min.	r ₁ min.	D _a max.	d _a min.
50	15,2	2,5	80	0,6	0,6	98	63
	15,2	2,5	80	0,6	0,6	98	63
	5,24	2,5	72	0,3	0,6	82	63
	5,24	2,5	72	0,3	0,6	82	63
60	13,7	3	85	0,6	0,6	100	82
70	19,8	3	95	0,6	0,6	110	92
80	27,6	3	105	0,6	0,6	120	102
90	59,9	3	120	0,6	0,6	138	116
100	85,3	3	132	0,6	0,6	150	128



d	Rigidity axial c _{aL} N/μm	Tilting rigidity c _{kL} Nm/mrad	Recommended INA precision locknuts ²⁾			Required locknut force ³⁾ axial N
			for radial clamping	for axial clamping	Tightening torque ⁴⁾ M _A Nm	
50	1 400	1 500	ZMA50/75	AM50	150	28 451
	1 400	1 500	ZMA50/75	AM50	150	28 451
	1 250	1 000	ZM50	AM50	85	16 280
	1 250	1 000	ZM50	AM50	85	16 280
60	1 300	1 650	ZMA60/98	AM60	100	16 700
70	1 450	2 250	ZMA70/110	AM70	130	19 031
80	1 600	3 000	ZMA80/120	AM80	160	20 604
90	1 700	4 400	ZMA90/130	AM90	200	22 731
100	1 900	5 800	ZMA100/140	AM100	250	25 624



Axial angular contact ball bearings

Without fixing holes
Less stringent tolerances

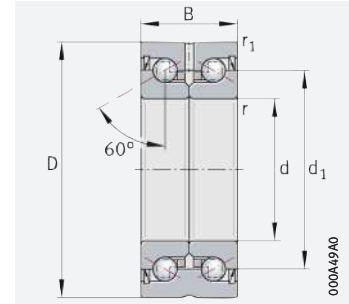

ZKLN...-2RS-PE

d = 6 – 50 mm

Main dimensions			Mass	Designation
d	D	B	m ≈ kg	
6	24	15	0,03	ZKLN0624-2RS-PE
10	34	20	0,1	ZKLN1034-2RS-PE
12	42	25	0,2	ZKLN1242-2RS-PE
15	45	25	0,21	ZKLN1545-2RS-PE
17	47	25	0,22	ZKLN1747-2RS-PE
20	52	28	0,31	ZKLN2052-2RS-PE
25	57	28	0,34	ZKLN2557-2RS-PE
30	62	28	0,39	ZKLN3062-2RS-PE
35	72	34	0,51	ZKLN3572-2RS-PE
50	90	34	0,88	ZKLN5090-2RS-PE

d	Basic load ratings		Fatigue limit load C_{ua} N	Limiting speed n_G grease min^{-1}	Thermally safe operating speed n_{θ} min^{-1}	Bearing frictional torque M_R Nm	Designation
	dyn. C_a N	stat. C_{0a} N					
6	6 900	8 500	375	16 400	6 800	0,04	ZKLN0624-2RS-PE
10	13 400	18 800	830	10 900	4 600	0,12	ZKLN1034-2RS-PE
12	16 900	24 700	1 090	9 200	3 800	0,16	ZKLN1242-2RS-PE
15	17 900	28 000	1 240	8 200	3 500	0,2	ZKLN1545-2RS-PE
17	18 800	31 000	1 380	7 600	3 300	0,24	ZKLN1747-2RS-PE
20	26 000	47 000	2 070	6 600	3 000	0,3	ZKLN2052-2RS-PE
25	27 500	55 000	2 450	5 700	2 600	0,4	ZKLN2557-2RS-PE
30	29 000	64 000	2 800	5 000	2 200	0,5	ZKLN3062-2RS-PE
35	41 000	89 000	3 950	4 400	2 000	0,6	ZKLN3572-2RS-PE
50	46 500	126 000	5 600	3 200	1 500	0,9	ZKLN5090-2RS-PE

medias ► <https://www.schaeffler.de/std/1E53>

④ Only valid in assembled condition.

- 1) Based on rotating inner ring.
- 2) The recommended INA precision locknuts are not included in the scope of delivery and must be ordered separately.
- 3) The required axial locknut force must be observed when using other locknuts.
- 4) Only valid in conjunction with INA precision locknuts.
Observe the guidelines on locating/locating bearing arrangements ► TPI 123.

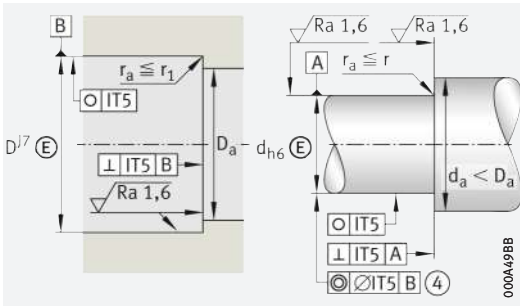

Design of housing and shaft (threaded spindle)

d	Mass moment of inertia ¹⁾ M _m kg · cm ²	Axial runout ¹⁾ μm	Dimensions			Mounting dimensions	
			d ₁	r min.	r ₁ min.	D _a max.	d _a min.
6	0,0044	5	14	0,3	0,6	19	9
10	0,029	5	21	0,3	0,6	28	14
12	0,068	5	25	0,3	0,6	33	16
15	0,102	5	28	0,3	0,6	35	20
17	0,132	5	30	0,3	0,6	37	23
20	0,273	5	34,5	0,3	0,6	43	25
25	0,486	5	40,5	0,3	0,6	48	32
30	0,73	5	45,5	0,3	0,6	53	40
35	1,51	5	52	0,3	0,6	62	45
50	5,24	5	72	0,3	0,6	82	63



d	Rigidity axial c _{aL} N/μm	Tilting rigidity c _{kL} Nm/mrad	Recommended INA precision locknuts ²⁾			Required locknut force ³⁾ axial N
			for radial clamping	for axial clamping	Tightening torque ⁴⁾ M _A Nm	
6	200	8	ZM06	–	2	2 404
10	325	25	ZM10	–	6	4 891
12	375	50	ZM12	–	8	5 307
15	400	65	ZM15	AM15	10	5 484
17	450	80	ZM17	AM17	15	7 514
20	650	140	ZM20	AM20	18	8 258
25	750	200	ZM25	AM25	25	9 123
30	850	300	ZM30	AM30	32	9 947
35	900	400	ZM35	AM35/38	40	10 770
50	1 250	1 000	ZM50	AM50	85	16 280



Axial angular contact ball bearings

Without fixing holes
Matched pair

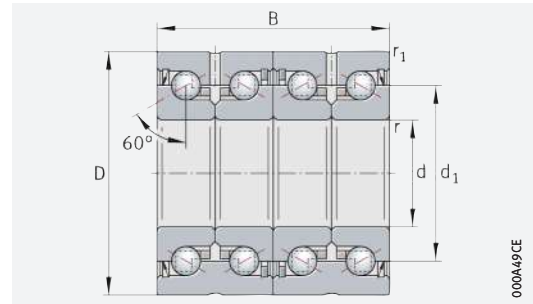

ZKLN...-2RS-2AP

000A9CE

d = 17 – 50 mm

Main dimensions			Mass	Designation
d	D	B	m ≈ kg	
17 0/-0,005	47 0/-0,01	50 0/-0,5	0,44	ZKLN1747-2RS-2AP-XL
20 0/-0,005	52 0/-0,01	56 0/-0,5	0,62	ZKLN2052-2RS-2AP-XL
25 0/-0,005	57 0/-0,01	56 0/-0,5	0,68	ZKLN2557-2RS-2AP-XL
30 0/-0,005	62 0/-0,01	56 0/-0,5	0,78	ZKLN3062-2RS-2AP-XL
35 0/-0,005	72 0/-0,01	68 0/-0,5	1,02	ZKLN3572-2RS-2AP-XL
40 0/-0,005	75 0/-0,01	68 0/-0,5	1,22	ZKLN4075-2RS-2AP-XL
50 0/-0,005	90 0/-0,01	68 0/-0,5	1,76	ZKLN5090-2RS-2AP-XL

d	Basic load ratings		Fatigue limit load C_{ua} N	Limiting speed n_G grease min^{-1}	Thermally safe operating speed n_{θ} min^{-1}	Bearing frictional torque M_R Nm	Designation
	axial dyn. C_a N	stat. C_{0a} N					
17	33 500	62 000	3 700	7 600	3 300	0,36	ZKLN1747-2RS-2AP-XL
20	46 000	94 000	5 500	6 600	3 000	0,45	ZKLN2052-2RS-2AP-XL
25	49 000	111 000	6 500	5 700	2 600	0,6	ZKLN2557-2RS-2AP-XL
30	52 000	127 000	7 500	5 000	2 200	0,75	ZKLN3062-2RS-2AP-XL
35	73 000	177 000	10 500	4 400	2 000	0,9	ZKLN3572-2RS-2AP-XL
40	77 000	202 000	11 900	4 000	1 800	1,05	ZKLN4075-2RS-2AP-XL
50	83 000	250 000	14 900	3 200	1 500	1,35	ZKLN5090-2RS-2AP-XL

medias ► <https://www.schaeffler.de/std/1E54>

Further sizes and designs with seals 2Z by agreement.

④ Only valid in assembled condition.

- 1) Based on rotating inner ring.
- 2) The recommended INA precision locknuts are not included in the scope of delivery and must be ordered separately.
- 3) The required axial locknut force must be observed when using other locknuts.
- 4) Only valid in conjunction with INA precision locknuts.
Observe the guidelines on locating/locating bearing arrangements ► TPI 123.

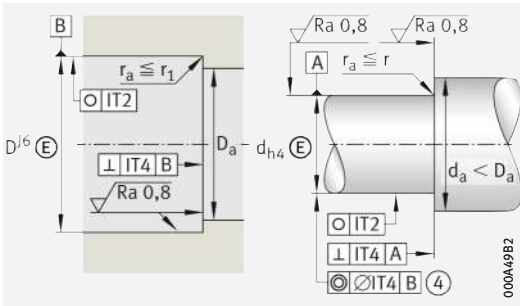

Design of housing and shaft (threaded spindle)

d	Mass moment of inertia ¹⁾ M_m kg · cm ²	Axial runout ¹⁾ μm	Dimensions			Mounting dimensions	
			d_1	r min.	r_1 min.	D_a max.	d_a min.
17	0,264	2	30	0,3	0,6	37	23
20	0,546	2	34,5	0,3	0,6	43	25
25	0,972	2	40,5	0,3	0,6	48	32
30	1,46	2,5	45,5	0,3	0,6	53	40
35	3,02	2,5	52	0,3	0,6	62	45
40	4,52	2,5	58	0,3	0,6	67	50
50	10,48	2,5	72	0,3	0,6	82	63



d	Rigidity axial c_{aL} N/μm	Tilting rigidity c_{kL} Nm/mrad	Recommended INA precision locknuts ²⁾			Required locknut force ³⁾ axial N
			for radial clamping	for axial clamping	Tightening torque ⁴⁾ M_A Nm	
17	800	200	ZM17	AM17	15	7 514
20	1 150	320	ZMA20/38	AM20	18	8 258
25	1 300	450	ZMA25/45	AM25	25	9 123
30	1 500	620	ZMA30/52	AM30	32	9 947
35	1 600	900	ZMA35/58	AM35/58	40	10 770
40	1 750	1 200	ZMA40/62	AM40	55	13 412
50	2 200	2 250	ZMA50/75	AM50	85	16 280



Axial angular contact ball bearings

Single direction
Open

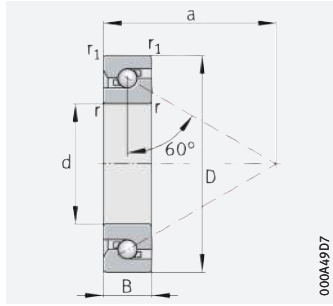

7602, 7603, BSB

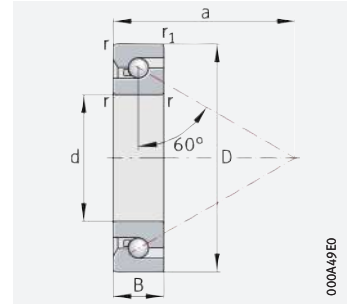

BSB..-SU

d = 12 – 20 mm

Main dimensions			Mass	Designation
d	D	B	m ≈ kg	
12 0/-0,004	32 0/-0,006	10 0/-0,08	0,042	7602012-TVP
15 0/-0,004	35 0/-0,006	11 0/-0,08	0,052	7602015-TVP
17 0/-0,004 0/-0,004 0/-0,004	40 0/-0,006	12 0/-0,08	0,074	7602017-TVP
	47 0/-0,006	15 0/-0,12	0,13	BSB1747-SU
20 0/-0,005 0/-0,005 0/-0,005 0/-0,005	47 0/-0,006	15 0/-0,12	0,13	BSB1747-SU-L055
	47 0/-0,006	14 0/-0,12	0,139	7602020-TVP
	47 0/-0,006	15 0/-0,12	0,12	BSB2047-SU
	47 0/-0,006	15 0/-0,12	0,12	BSB2047-SU-L055
	52 0/-0,007	15 0/-0,12	0,17	7603020-TVP

d	Basic load ratings		Fatigue limit load C_{ua} N	Limiting speed n_G grease min^{-1}	Thermally safe operating speed n_θ min^{-1}	Bearing frictional torque ¹⁾ M_R Nm	Designation
	axial dyn. C_a N	stat. C_{0a} N					
12	12 200	20 700	920	14 100	8 000	0,015	7602012-TVP
15	13 100	24 700	1 090	12 300	6 700	0,02	7602015-TVP
17	17 200	32 500	1 430	10 600	6 000	0,03	7602017-TVP
	26 000	47 000	2 070	8 700	6 200	0,08	BSB1747-SU
	26 000	47 000	2 070	8 700	6 200	0,08	BSB1747-SU-L055
20	19 100	38 000	1 670	9 200	5 000	0,05	7602020-TVP
	26 000	47 000	2 070	8 700	6 200	0,08	BSB2047-SU
	26 000	47 000	2 070	8 700	6 200	0,08	BSB2047-SU-L055
	25 500	53 000	2 360	8 200	4 500	0,06	7603020-TVP

medias ► <https://www.schaeffler.de/std/1E55>

④ Only valid in assembled condition.

- 1) Valid for single bearings with stated preload force.
- 2) Valid for matched pair of bearings in O or X arrangement.
- 3) Based on rotating inner ring.
- 4) The recommended INA precision locknuts are not included in the scope of delivery and must be ordered separately.
- 5) The required axial locknut force must be observed when using other locknuts.
- 6) Only valid in conjunction with INA precision locknuts.
Observe the guidelines on locating/locating bearing arrangements ► \square TPI 123.

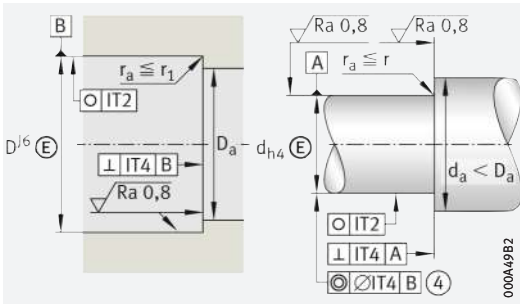

Design of housing and shaft (threaded spindle)

d	Dimensions			Mounting dimensions			
	r min.	r ₁ min.	a ≈	D _a max.		d _a min.	
12	0,6	0,6	24	27	H12	17	h12
15	0,6	0,6	27,5	30	H12	20,5	h12
17	0,6	0,6	31	34,5	H12	23	h12
	1	0,6	29,9	43	H12	27	h12
	1	0,6	29,9	43	H12	27	h12
20	1	1	36	39,5	H12	27,5	h12
	1	0,6	29,9	43	H12	27	h12
	1	0,6	29,9	43	H12	27	h12
	1,1	1,1	39,5	43,5	H12	30,5	h12



d	Rigidity ²⁾	Axial runout ³⁾	Recommended INA precision locknuts ⁴⁾			Required locknut force ⁵⁾
	axial		for radial clamping	for axial clamping	Tightening torque ⁶⁾	
	c _{aL}				M _A	axial
	N/μm	μm			Nm	N
12	476	2	ZM12	–	8	6 110
15	516	2	ZM15	AM15	10	5 740
17	596	2	ZM17	AM17	15	8 060
	764	2	ZM17	AM17	15	9 000
	764	2	ZM17	AM17	15	9 000
20	703	2	ZM20	AM20	18	8 490
	764	2	ZM20	AM20	18	9 000
	764	2	ZM20	AM20	18	9 000
	787	2	ZM20	AM20	25	11 600



Axial angular contact ball bearings

Single direction
Open

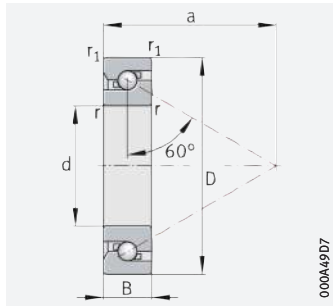

7602, 7603, BSB

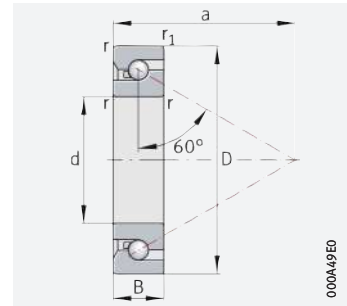

BSB..-SU

d = 25 – 30 mm

Main dimensions			Mass	Designation	
d	D	B	m ≈ kg		
25	0/-0,005	52 0/-0,007	15 0/-0,12	0,147	7602025-TVP
	0/-0,005	62 0/-0,007	17 0/-0,12	0,275	7603025-TVP
	0/-0,005	62 0/-0,007	15 0/-0,12	0,24	BSB2562-SU
	0/-0,005	62 0/-0,007	15 0/-0,12	0,24	BSB2562-SU-L055
30	0/-0,005	62 0/-0,007	16 0/-0,12	0,232	7602030-TVP
	0/-0,005	62 0/-0,007	15 0/-0,12	0,22	BSB3062-SU
	0/-0,005	62 0/-0,007	15 0/-0,12	0,22	BSB3062-SU-L055
	0/-0,005	72 0/-0,007	19 0/-0,12	0,409	7603030-TVP

d	Basic load ratings		Fatigue limit load C_{ua} N	Limiting speed n_G grease min^{-1}	Thermally safe operating speed n_θ min^{-1}	Bearing frictional torque ¹⁾ M_R Nm	Designation
	axial						
	dyn. C_a N	stat. C_{0a} N					
25	23 200	50 000	2 220	8 000	4 500	0,07	7602025-TVP
	29 500	68 000	3 000	6 800	3 800	0,09	7603025-TVP
	29 000	64 000	2 800	6 700	5 400	0,13	BSB2562-SU
	29 000	64 000	2 800	6 700	5 400	0,13	BSB2562-SU-L055
30	27 500	66 000	2 900	6 700	3 800	0,09	7602030-TVP
	29 000	64 000	2 800	6 700	5 400	0,13	BSB3062-SU
	29 000	64 000	2 800	6 700	5 400	0,13	BSB3062-SU-L055
	36 500	89 000	3 950	5 700	3 200	0,13	7603030-TVP

medias ► <https://www.schaeffler.de/std/1E56>

④ Only valid in assembled condition.

- 1) Valid for single bearings with stated preload force.
- 2) Valid for matched pair of bearings in O or X arrangement.
- 3) Based on rotating inner ring.
- 4) The recommended INA precision locknuts are not included in the scope of delivery and must be ordered separately.
- 5) The required axial locknut force must be observed when using other locknuts.
- 6) Only valid in conjunction with INA precision locknuts.
Observe the guidelines on locating/locating bearing arrangements ► □ TPI 123.

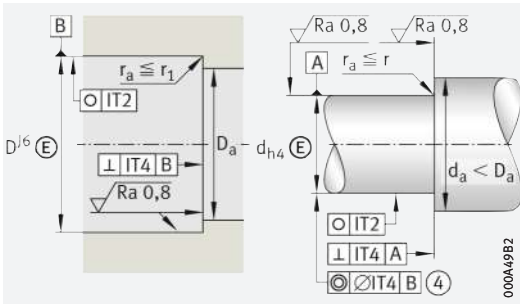

Design of housing and shaft (threaded spindle)

d	Dimensions			Mounting dimensions			
	r min.	r ₁ min.	a ≈	D _a max.		d _a min.	
25	1	1	41	45	H12	32	h12
	1,1	1,1	47,5	52	H12	38	h12
	1	0,6	39,4	54	H12	38	h12
	1	0,6	39,4	54	H12	38	h12
30	1	1	48	52,5	H12	39,5	h12
	1	0,6	39,4	54	H12	38	h12
	1	0,6	39,4	54	H12	38	h12
	1,1	1,1	55,5	61	H12	45	h12



d	Rigidity ²⁾	Axial runout ³⁾ μm	Recommended INA precision locknuts ⁴⁾			Required locknut force ⁵⁾ axial N
	axial c _{aL} N/μm		for radial clamping	for axial clamping	Tightening torque ⁶⁾ M _A Nm	
25	772	2	ZM25	AM25	25	9 430
	917	2	ZM25	AM25	40	14 480
	1 001	2	ZMA25/45	AM25	30	11 810
	1 001	2	ZMA25/45	AM25	30	11 810
30	893	2	ZM30	AM30	32	10 240
	1 034	2,5	ZM30	AM30	32	11 080
	1 034	2,5	ZM30	AM30	32	11 080
	1 073	2	ZM30	AM30	55	16 180



Axial angular contact ball bearings

Single direction
Open

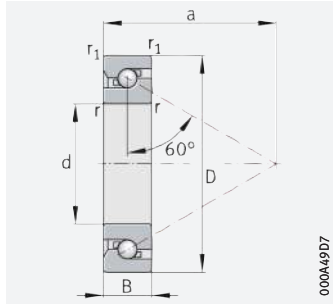

7602, 7603, BSB

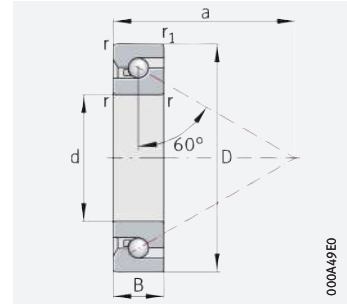

BSB..-SU

d = 35 – 40 mm

Main dimensions			Mass	Designation	
d	D	B	m ≈ kg		
35	0/-0,006	72 0/-0,007	17 0/-0,12	0,339	7602035-TVP
	0/-0,006	72 0/-0,007	15 0/-0,12	0,3	BSB3572-SU
	0/-0,006	72 0/-0,007	15 0/-0,12	0,3	BSB3572-SU-L055
	0/-0,006	80 0/-0,007	21 0/-0,12	0,546	7603035-TVP
40	0/-0,006	72 0/-0,007	15 0/-0,12	0,26	BSB4072-SU
	0/-0,006	72 0/-0,007	15 0/-0,12	0,26	BSB4072-SU-L055
	0/-0,006	80 0/-0,007	18 0/-0,12	0,418	7602040-TVP
	0/-0,006	90 0/-0,008	23 0/-0,12	0,751	7603040-TVP
	0/-0,006	90 0/-0,008	20 0/-0,12	0,65	BSB040090-T

d	Basic load ratings		Fatigue limit load C_{ua} N	Limiting speed n_G grease min^{-1}	Thermally safe operating speed n_{θ} min^{-1}	Bearing frictional torque ¹⁾ M_R Nm	Designation
	axial dyn. C_a N	stat. C_{0a} N					
35	31 500	81 000	3 600	5 700	3 200	0,12	7602035-TVP
	37 000	89 000	3 950	5 400	4 700	0,18	BSB3572-SU
	37 000	89 000	3 950	5 400	4 700	0,18	BSB3572-SU-L055
	38 000	100 000	4 450	5 100	3 000	0,17	7603035-TVP
40	37 000	89 000	3 950	5 400	4 700	0,18	BSB4072-SU
	37 000	89 000	3 950	5 400	4 700	0,18	BSB4072-SU-L055
	39 000	106 000	4 650	4 900	2 800	0,17	7602040-TVP
	52 000	138 000	6 100	4 500	2 600	0,23	7603040-TVP
	52 000	138 000	6 100	4 500	3 100	0,23	BSB040090-T

medias ► <https://www.schaeffler.de/std/1E57>

④ Only valid in assembled condition.

- 1) Valid for single bearings with stated preload force.
- 2) Valid for matched pair of bearings in O or X arrangement.
- 3) Based on rotating inner ring.
- 4) The recommended INA precision locknuts are not included in the scope of delivery and must be ordered separately.
- 5) The required axial locknut force must be observed when using other locknuts.
- 6) Only valid in conjunction with INA precision locknuts.
Observe the guidelines on locating/locating bearing arrangements ► □ TPI 123.

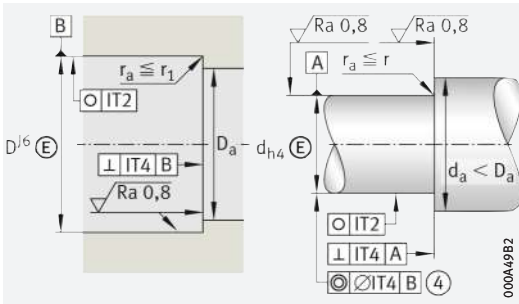

Design of housing and shaft (threaded spindle)

d	Dimensions			Mounting dimensions			
	r min.	r ₁ min.	a ≈	D _a max.		d _a min.	
35	1,1	1,1	55	60,5	H12	46,5	h12
	1	0,6	48,5	65	H12	47	h12
	1	0,6	48,5	65	H12	47	h12
	1,5	1,5	61,5	67	H12	51	h12
40	1	0,6	48,5	65	H12	47	h12
	1	0,6	48,5	65	H12	47	h12
	1,1	1,1	62,5	69,5	H12	53,5	h12
	1,5	1,5	68,5	75,5	H12	56,5	h12
	1,5	1,5	67	75,5	H12	56,5	h12
	1,5	1,5	67	75,5	H12	56,5	h12



d	Rigidity ²⁾	Axial runout ³⁾	Recommended INA precision locknuts ⁴⁾			Required locknut force ⁵⁾
	axial		for radial clamping	for axial clamping	Tightening torque ⁶⁾	
	c _{aL}				M _A	axial
	N/μm	μm			Nm	N
35	1 020	2	ZM35	AM35	40	11 310
	1 196	2,5	ZM35	AM35	50	15 220
	1 196	2,5	ZM35	AM35	50	15 220
	1 192	2	ZM35	AM35	65	17 380
40	1 235	2,5	ZM40	AM40	60	15 650
	1 235	2,5	ZM40	AM40	60	15 650
	1 190	2	ZM40	AM40	55	13 330
	1 292	2	ZM40	AM40	110	25 120
	1 292	2	ZM40	AM40	110	25 120
	1 292	2	ZM40	AM40	110	25 120



Axial angular contact ball bearings

Single direction
Open

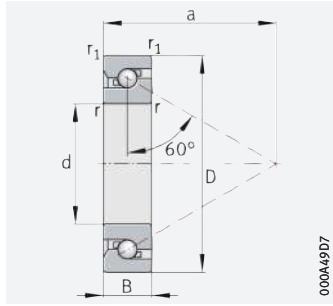

7602, 7603, BSB

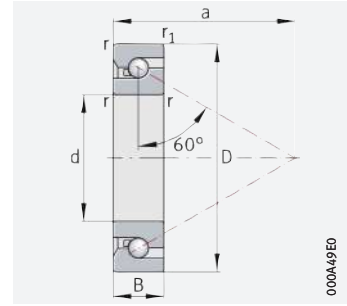

BSB..-SU

d = 45 – 50 mm

Main dimensions			Mass	Designation
d	D	B	m ≈ kg	
45 0/-0,006	75 0/-0,007	15 0/-0,12	0,26	BSB045075-T
	85 0/-0,008	19 0/-0,12	0,488	7602045-TVP
	100 0/-0,008	25 0/-0,12	0,992	7603045-TVP
	100 0/-0,008	20 0/-0,12	0,81	BSB045100-T
50 0/-0,006	90 0/-0,008	20 0/-0,12	0,557	7602050-TVP
	100 0/-0,008	20 0/-0,12	0,75	BSB050100-T
	110 0/-0,008	27 0/-0,12	1,29	7603050-TVP

d	Basic load ratings		Fatigue limit load C_{ua} N	Limiting speed n_G grease min^{-1}	Thermally safe operating speed n_{θ} min^{-1}	Bearing frictional torque ¹⁾ M_R Nm	Designation
	axial dyn. C_a N	stat. C_{0a} N					
45	30 000	85 000	3 750	5 100	3 300	0,13	BSB045075-T
	39 500	111 000	4 900	4 700	2 600	0,19	7602045-TVP
	62 000	172 000	7 600	4 000	2 200	0,3	7603045-TVP
	62 000	172 000	7 600	4 000	2 700	0,3	BSB045100-T
50	41 000	122 000	5 400	4 300	2 400	0,23	7602050-TVP
	62 000	172 000	7 600	4 000	2 700	0,33	BSB050100-T
	72 000	203 000	9 000	3 600	2 000	0,36	7603050-TVP

medias ► <https://www.schaeffler.de/std/1E58>

④ Only valid in assembled condition.

- 1) Valid for single bearings with stated preload force.
- 2) Valid for matched pair of bearings in O or X arrangement.
- 3) Based on rotating inner ring.
- 4) The recommended INA precision locknuts are not included in the scope of delivery and must be ordered separately.
- 5) The required axial locknut force must be observed when using other locknuts.
- 6) Only valid in conjunction with INA precision locknuts.
Observe the guidelines on locating/locating bearing arrangements ► □ TPI 123.

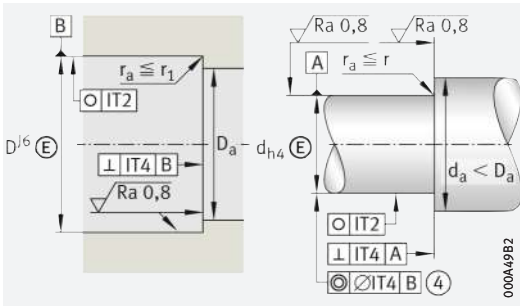

Design of housing and shaft (threaded spindle)

d	Dimensions			Mounting dimensions			
	r min.	r ₁ min.	a ≈	D _a max.		d _a min.	
45	1	1	59,5	68	H12	52	h12
	1,1	1,1	66	73	H12	57	h12
	1,5	1,5	77,5	85,5	H12	64,5	h12
	1,5	1,5	75	85,5	H12	64,5	h12
50	1,1	1,1	71,5	79	H12	63	h12
	1,5	1,5	75	85,5	H12	64,5	h12
	2	2	85,5	94	H12	72	h12

d	Rigidity ²⁾	Axial runout ³⁾	Recommended INA precision locknuts ⁴⁾			Required locknut force ⁵⁾
	axial		for radial clamping	for axial clamping	Tightening torque ⁶⁾	
	c _{aL}	N/μm	μm			M _A
45	1 072	2	ZM45	AM45	50	11 140
	1 247	2	ZM45	AM45	65	14 410
	1 473	2	ZM45	AM45	120	25 160
	1 473	2	ZM45	AM45	120	25 160
50	1 360	2	ZM50	AM50	85	16 810
	1 473	2	ZM50	AM50	120	23 770
	1 601	2	ZM50	AM50	150	28 930





Axial angular contact ball bearings

Single direction
Open

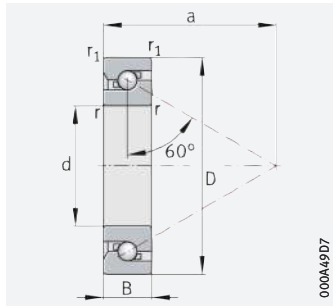

7602, 7603, BSB

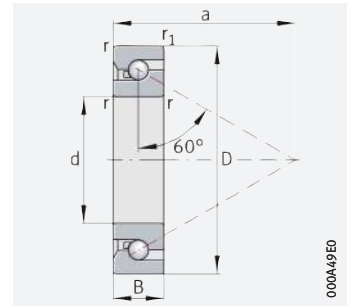

BSB..-SU

d = 55 – 60 mm

Main dimensions			Mass	Designation
d	D	B	m ≈ kg	
55 0/-0,007	90 0/-0,008	15 0/-0,15	0,38	BSB055090-T
	100 0/-0,008	21 0/-0,15	0,74	7602055-TVP
	120 0/-0,008	29 0/-0,15	1,67	7603055-TVP⁷⁾
	120 0/-0,008	20 0/-0,15	1,2	BSB055120-T⁷⁾
60 0/-0,007	120 0/-0,008	20 0/-0,15	1,1	BSB060120-T

d	Basic load ratings		Fatigue limit load C_{ua} N	Limiting speed n_G grease min^{-1}	Thermally safe operating speed n_{θ} min^{-1}	Bearing frictional torque ¹⁾ M_R Nm	Designation
	axial dyn. C_a N	stat. C_{0a} N					
55	33 500	98 000	4 300	4 200	2 800	0,19	BSB055090-T
	42 000	132 000	5 800	3 900	2 200	0,25	7602055-TVP
	85 000	255 000	11 200	3 300	1 900	0,46	7603055-TVP⁷⁾
	63 000	188 000	8 300	3 400	2 400	0,36	BSB055120-T⁷⁾
60	64 000	196 000	8 700	3 800	2 300	0,38	BSB060120-T

medias ► <https://www.schaeffler.de/std/1E59>

④ Only valid in assembled condition.

- 1) Valid for single bearings with stated preload force.
- 2) Valid for matched pair of bearings in O or X arrangement.
- 3) Based on rotating inner ring.
- 4) The recommended INA precision locknuts are not included in the scope of delivery and must be ordered separately.
- 5) The required axial locknut force must be observed when using other locknuts.
- 6) Only valid in conjunction with INA precision locknuts.
Observe the guidelines on locating/locating bearing arrangements ► TPI 123.
- 7) Delivery possibility by agreement.

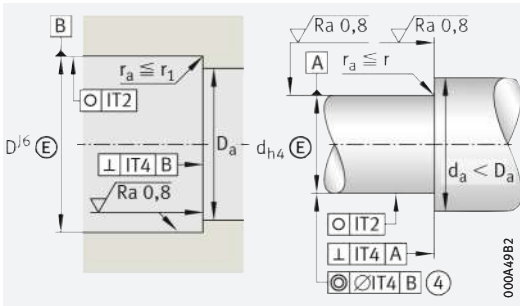

Design of housing and shaft (threaded spindle)

d	Dimensions			Mounting dimensions			
	r min.	r ₁ min.	a ≈	D _a max.	H12	d _a min.	h12
55	1	1	70,5	80	H12	65	h12
	1,5	1,5	77,5	85,5	H12	69,5	h12
	2	2	91,5	101	H12	77	h12
	2	2	86	97,5	H12	77	h12
60	1,5	1,5	88	100,5	H12	79,5	h12

d	Rigidity ²⁾		Axial runout ³⁾	Recommended INA precision locknuts ⁴⁾			Required locknut force ⁵⁾ axial
	axial			for radial clamping	for axial clamping	Tightening torque ⁶⁾ M _A	
	c _{aL}	N/μm	μm			Nm	N
55		1 246	3	ZM55	AM55	60	12 040
		1 394	3	ZM55	AM55	85	15 060
		1 723	3	ZM55	AM55	130	24 120
		1 553	3	ZM55	AM55	110	20 070
60		1 623	3	ZM60	AM60	120	20 020





Axial angular contact ball bearings

Single direction
Sealed on both sides

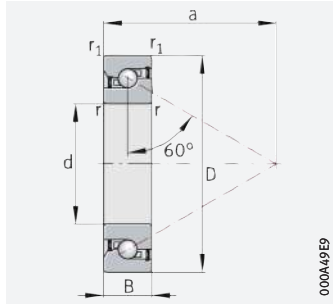

7602..-2RS, 7603..-2RS, BSB..-2RS

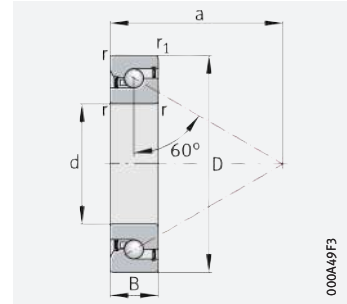

BSB..-2Z-SU

d = 12 – 20 mm

Main dimensions			Mass	Designation
d	D	B	m ≈ kg	
12 0/-0,004	32 0/-0,006	10 0/-0,08	0,042	7602012-2RS-TVP
15 0/-0,004	35 0/-0,006	11 0/-0,08	0,052	7602015-2RS-TVP
17 0/-0,004	47 0/-0,006	15 0/-0,12	0,13	BSB1747-2Z-SU
20 0/-0,005 0/-0,005 0/-0,005	47 0/-0,006	14 0/-0,12	0,12	7602020-2RS-TVP
	47 0/-0,006	15 0/-0,12	0,12	BSB2047-2Z-SU
	52 0/-0,007	15 0/-0,12	0,17	7603020-2RS-TVP

d	Basic load ratings		Fatigue limit load C_{ua} N	Limiting speed n_G grease min^{-1}	Thermally safe operating speed n_θ min^{-1}	Bearing frictional torque ¹⁾ M_R Nm	Designation
	axial dyn. C_a N	stat. C_{0a} N					
12	12 200	20 700	920	10 400	8 000	0,015	7602012-2RS-TVP
15	13 100	24 700	1 090	9 000	6 700	0,02	7602015-2RS-TVP
17	26 000	47 000	2 070	8 700	6 200	0,08	BSB1747-2Z-SU
20	19 100	38 000	1 670	6 800	5 000	0,05	7602020-2RS-TVP
	26 000	47 000	2 070	8 700	6 200	0,08	BSB2047-2Z-SU
	25 500	53 000	2 360	6 200	4 500	0,06	7603020-2RS-TVP

medias ► <https://www.schaeffler.de/std/1E5A>

④ Only valid in assembled condition.

- 1) Valid for single bearings with stated preload force.
- 2) Valid for matched pair of bearings in O or X arrangement.
- 3) Based on rotating inner ring.
- 4) The recommended INA precision locknuts are not included in the scope of delivery and must be ordered separately.
- 5) The required axial locknut force must be observed when using other locknuts.
- 6) Only valid in conjunction with INA precision locknuts.
Observe the guidelines on locating/locating bearing arrangements ► TPI 123.

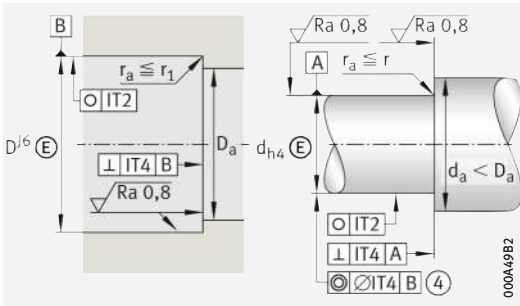

Design of housing and shaft (threaded spindle)

d	Dimensions			Mounting dimensions			
	r min.	r ₁ min.	a ≈	D _a max.		d _a min.	
12	0,6	0,6	24	27	H12	17	h12
15	0,6	0,6	27,5	30	H12	20,5	h12
17	1	0,6	29,9	43	H12	27	h12
20	1	1	36	39,5	H12	27,5	h12
	1	0,6	29,9	43	H12	27	h12
	1,1	1,1	36,5	43,5	H12	30,5	h12

d	Rigidity ²⁾	Axial runout ³⁾	Recommended INA precision locknuts ⁴⁾			Required locknut force ⁵⁾
	axial c _{aL} N/μm		for radial clamping	for axial clamping	Tightening torque ⁶⁾ M _A Nm	
12	476	2	ZM12	–	8	6 110
15	516	2	ZM15	AM15	10	5 740
17	764	2	ZM17	AM17	15	9 000
20	703	2	ZM20	AM20	18	8 490
	764	2	ZM20	AM20	18	9 000
	787	2	ZM20	AM20	18	11 600





Axial angular contact ball bearings

Single direction
Sealed on both sides

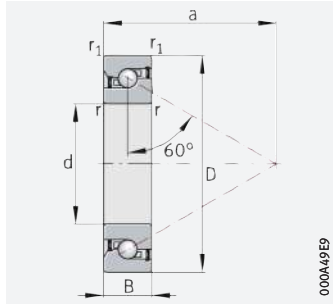

7602..-2RS, 7603..-2RS, BSB..-2RS

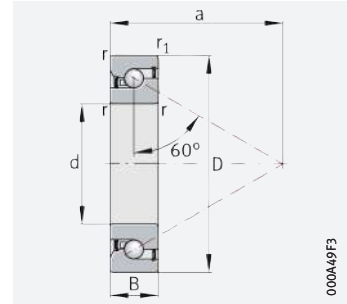

BSB..-2Z-SU

d = 25 – 40 mm

Main dimensions			Mass	Designation
d	D	B	m ≈ kg	
25 0/-0,005	52 0/-0,007	15 0/-0,12	0,15	7602025-2RS-TVP
	62 0/-0,007	17 0/-0,12	0,27	7603025-2RS-TVP
	62 0/-0,007	15 0/-0,12	0,24	BSB2562-2Z-SU
30 0/-0,005	62 0/-0,007	16 0/-0,12	0,23	7602030-2RS-TVP
	62 0/-0,007	15 0/-0,12	0,22	BSB3062-2Z-SU
35 0/-0,006	72 0/-0,007	15 0/-0,12	0,3	BSB3572-2Z-SU
40 0/-0,006	72 0/-0,007	15 0/-0,12	0,26	BSB4072-2Z-SU

d	Basic load ratings		Fatigue limit load C_{ua} N	Limiting speed n_G grease min^{-1}	Thermally safe operating speed n_{θ} min^{-1}	Bearing frictional torque ¹⁾ M_R Nm	Designation
	axial dyn. C_a N	stat. C_{0a} N					
25	23 200	50 000	2 220	5 100	3 800	0,07	7602025-2RS-TVP
	29 500	68 000	3 000	5 100	3 800	0,09	7603025-2RS-TVP
	29 000	64 000	2 800	6 700	5 400	0,13	BSB2562-2Z-SU
30	27 500	66 000	2 900	5 000	3 800	0,09	7602030-2RS-TVP
	29 000	64 000	2 800	6 700	5 400	0,13	BSB3062-2Z-SU
35	37 000	89 000	3 950	5 400	4 700	0,18	BSB3572-2Z-SU
40	37 000	89 000	3 950	5 400	4 700	0,18	BSB4072-2Z-SU

medias ► <https://www.schaeffler.de/std/1E5B>

④ Only valid in assembled condition.

- 1) Valid for single bearings with stated preload force.
- 2) Valid for matched pair of bearings in O or X arrangement.
- 3) Based on rotating inner ring.
- 4) The recommended INA precision locknuts are not included in the scope of delivery and must be ordered separately.
- 5) The required axial locknut force must be observed when using other locknuts.
- 6) Only valid in conjunction with INA precision locknuts.
Observe the guidelines on locating/locating bearing arrangements ► □ TPI 123.

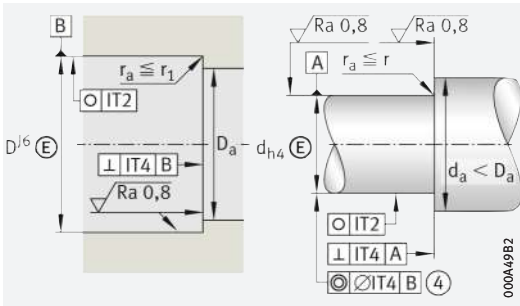

Design of housing and shaft (threaded spindle)

d	Dimensions			Mounting dimensions			
	r min.	r ₁ min.	a ≈	D _a max.		d _a min.	
25	1	1	41	45	H12	32	h12
	1,1	1,1	47,5	52	H12	38	h12
	1	0,6	39,4	54	H12	38	h12
30	1	1	48	52,5	H12	39,5	h12
	1	0,6	39,4	54	H12	38	h12
35	1	0,6	48,5	65	H12	47	h12
40	1	0,6	48,5	65	H12	47	h12



d	Rigidity ²⁾	Axial runout ³⁾	Recommended INA precision locknuts ⁴⁾			Required locknut force ⁵⁾
	axial c _{aL} N/μm		for radial clamping	for axial clamping	Tightening torque ⁶⁾ M _A Nm	
25	772	2	ZM25	AM25	25	9 430
	917	2	ZM25	AM25	40	14 480
	1 001	2	ZMA25/45	AM25	30	11 810
30	893	2	ZM30	AM30	32	10 240
	1 034	2,5	ZM30	AM30	32	11 080
35	1 196	2,5	ZM35	AM35	50	15 220
40	1 235	2,5	ZM40	AM40	60	15 650

Angular contact ball bearing units

For screw mounting

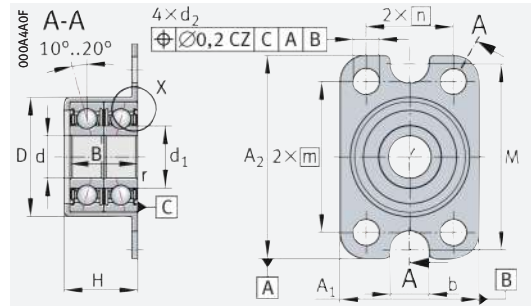

ZKLR0624-2Z, ZKLR0828-2Z

d = 6 – 20 mm

Main dimensions				Dimensions			Designation
d	D	B	d ₁	r min.	d ₂		
6 0,000/-0,008	20,5 +0,03/-0,01	12 +0,25/-0,25	9	0,3	4,5	ZKLR0624-2Z	
8 0,000/-0,008	23,9 +0,03/-0,01	14 +0,25/-0,25	11	0,3	4,5	ZKLR0828-2Z	
10 0,000/-0,008	28,14 +0,03/-0,01	16 +0,25/-0,25	13,55	0,3	4,5	ZKLR1035-2Z	
12 0,000/-0,007	35,45 +0,03/-0,01	20 +0,25/-0,25	16,6	0,3	6,6	ZKLR1244-2RS	
15 0,000/-0,007	38,45 +0,03/-0,01	22 +0,25/-0,25	18	0,3	6,6	ZKLR1547-2RS	
20 0,000/-0,008	50,45 +0,03/-0,01	28 +0,25/-0,25	24,4	0,3	6,6	ZKLR2060-2RS	

d	Basic load ratings				Fatigue limit load C _{ur} N	Limiting speed n _{G grease} min ⁻¹	Bearing frictional torque M _R Nm	Mass m ≈ kg	Designation
	radial		axial						
	dyn. C _r N	stat. C _{0r} N	dyn. C _a N	stat. C _{0a} N					
6	4 100	2 060	1 650	1 520	104	7 300	0,04	0,023	ZKLR0624-2Z
8	5 000	2 700	2 060	1 850	138	6 200	0,08	0,03	ZKLR0828-2Z
10	7 000	3 900	2 430	2 420	197	5 100	0,12	0,05	ZKLR1035-2Z
12	13 600	8 500	13 200	17 900	430	3 700	0,16	0,12	ZKLR1244-2RS
15	16 700	10 700	16 400	22 400	540	3 400	0,2	0,14	ZKLR1547-2RS
20	28 000	19 100	27 500	40 000	970	2 800	0,3	0,3	ZKLR2060-2RS

medias ► <https://www.schaeffler.de/std/1E5C>

② Adjacent construction, bearing screw mounted on flat surface. ④ Only valid in assembled condition.

- The screws are not included in the scope of delivery. Tightening torque according to manufacturer's data.
- Statistically determined mean values from measurements on the complete bearing. Due to the design, larger variations in rigidity must be expected with axial angular contact ball bearing units ZKLR.
- Based on rotating inner ring.
- The locknut is only used to axially locate the bearing unit. It has no influence on the bearing preload.
- The recommended INA precision locknuts are not included in the scope of delivery and must be ordered separately.
- Only valid in conjunction with INA precision locknuts. Observe the guidelines on locating/locating bearing arrangements ► [TPI 123](#).
- The geometrical tolerances stated are only required in the area of the diameter between D_{ai} and D_{aa}. When IT5-7 is stated, the tolerance should be selected as IT5 to IT7 depending on the accuracy requirement of the subassembly.

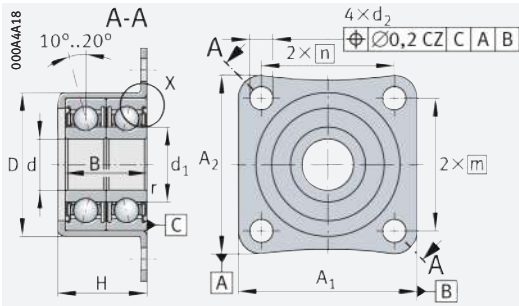

ZKLR1035-2Z

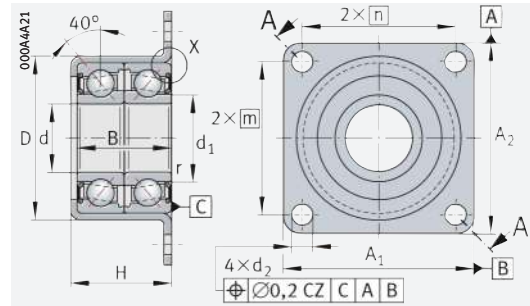

ZKLR1244-2RS, ZKLR1547-2RS, ZKLR2060-2RS

Dimensions								Mounting dimensions			Fixing screws ¹⁾ DIN EN ISO 4762				
d	A ₁	A ₂	b	m	n	M	H	d _a	D _{ai}	D _{aa} min.	Size	n	Size	n	t ₁ °
6	24	35	6,6	26	15	32	13	8	16	19	M4	4	M6	2	0,2
8	28	35	6,6	26	20	35	15,5	10,4	18	22	M4	4	M6	2	0,2
10	35	35	–	26	26	–	17,5	12,4	22	26	M4	4	–	–	0,2
12	44	50	–	38	32	–	22	14	27	32	M6	4	–	–	0,2
15	47	51	–	39	35	–	24	17,5	29	35	M6	4	–	–	0,2
20	60	60	–	47	47	–	30	24	39	47	M6	4	–	–	0,2

d	Rigidity ²⁾ axial	Mass moment of inertia ³⁾ M _m	Axial runout ³⁾ μm	Recommended INA precision locknuts ^{4) 5)}		
	c _{aL} N/μm			for radial clamping	for axial clamping	Tightening torque ⁶⁾ M _A Nm
6	14	0,0014	7	ZM06	–	2
8	16	0,0028	7	ZM08	–	4
10	19	0,0075	7	ZM10	–	6
12	170	0,0102	7	ZM12	–	8
15	200	0,0178	7	ZM15	AM15	10
20	250	0,263	8	ZM20	AM20	18

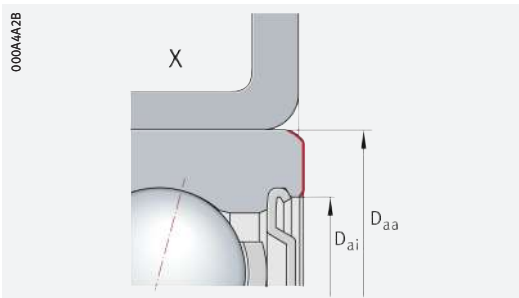

Axial abutment area of outer ring

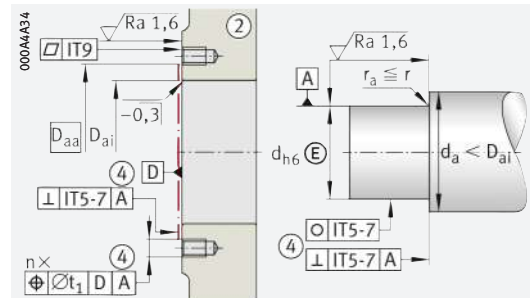

Design of housing and shaft⁷⁾



Double row axial angular contact ball bearings with flange

With fixing holes

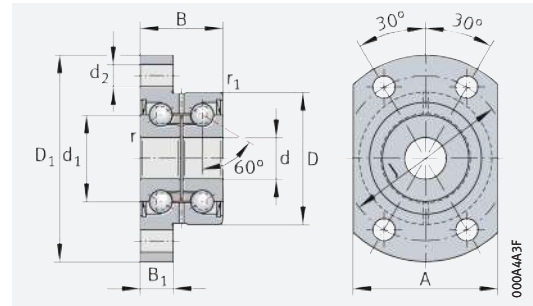

ZKLFA...-2RS, ZKLFA...-2Z

d = 6 – 8 mm

Main dimensions			Dimensions			Designation	
d	D	B	d ₁	D ₁	r min.		
6	+0,002 / -0,003	19 0 / -0,01	12 0 / -0,25	12	30	0,3	ZKLFA0630-2Z ²⁾
	+0,002 / -0,003	24 0 / -0,01	15 0 / -0,25	14	40	0,3	ZKLFA0640-2RS
	+0,002 / -0,003	24 0 / -0,01	15 0 / -0,25	14	40	0,3	ZKLFA0640-2Z
8	0 / -0,005	32 0 / -0,01	20 0 / -0,25	19	50	0,3	ZKLFA0850-2RS
	0 / -0,005	32 0 / -0,01	20 0 / -0,25	19	50	0,3	ZKLFA0850-2Z

d	Basic load ratings axial		Fatigue limit load C _{ua} N	Limiting speed n _G grease min ⁻¹	Thermally safe operating speed n _θ min ⁻¹	Bearing frictional torque M _R Nm	Mass m ≈ kg	Designation
	dyn. C _a N	stat. C _{0a} N						
6	4 900	6 100	270	22 800	14 000	0,01	0,05	ZKLFA0630-2Z ²⁾
	6 900	8 500	375	16 400	6 800	0,04	0,08	ZKLFA0640-2RS
	6 900	8 500	375	19 900	12 000	0,02	0,08	ZKLFA0640-2Z
8	12 500	16 300	720	12 100	5 100	0,08	0,17	ZKLFA0850-2RS
	12 500	16 300	720	15 500	9 500	0,04	0,17	ZKLFA0850-2Z

medias ► <https://www.schaeffler.de/std/1E5D>

② Adjacent construction, bearing screw mounted on flat surface ④ Only valid in assembled condition.

- 1) Screws 10.9 are not included in the scope of delivery. Tightening torque according to manufacturer's data.
- 2) No relubrication facility.
- 3) Based on rotating inner ring.
- 4) The recommended INA precision locknuts are not included in the scope of delivery and must be ordered separately.
- 5) The required axial locknut force must be observed when using other locknuts.
- 6) Only valid in conjunction with INA precision locknuts. Observe the guidelines on locating/locating bearing arrangements ► □ TPI 123.

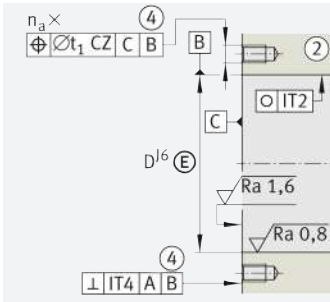

Housing design

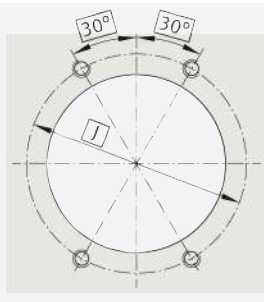

000A449

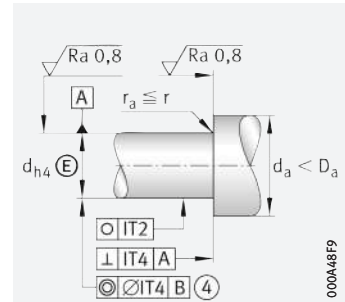

000A48F9

Shaft design
(threaded spindle)

Dimensions						Mounting dimensions			Fixing screws ¹⁾ DIN EN ISO 4762	
d	r ₁ min.	B ₁	d ₂	J	A	d _a		t ₁	Size	n _a
						min.	max.			
6	0,3	5	3,5	24	22	9	15	0,1	M3	4
	0,6	6	4,5	32	27	9	18	0,1	M4	4
	0,6	6	4,5	32	27	9	18	0,1	M4	4
8	0,6	8	5,5	40	35	11	25	0,1	M5	4
	0,6	8	5,5	40	35	11	25	0,1	M5	4

d	Rigidity	Tilting rigidity	Mass moment of inertia ³⁾	Axial runout ³⁾	Recommended INA precision locknuts ⁴⁾			Required locknut force ⁵⁾
	axial				for radial clamping	for axial clamping	Tightening torque ⁶⁾	axial
	c _{aL}	c _{kL}	M _m	μm			M _A	
	N/μm	Nm/mrad	kg · cm ²				Nm	N
6	150	4	0,0019	2	ZM06	–	2	2 010
	200	8	0,0044	2	ZM06	–	2	2 404
	200	8	0,0044	2	ZM06	–	2	2 404
8	250	20	0,02	2	ZM08	–	4	3 468
	250	20	0,02	2	ZM08	–	4	3 468





Double row axial angular contact ball bearings with flange

With fixing holes

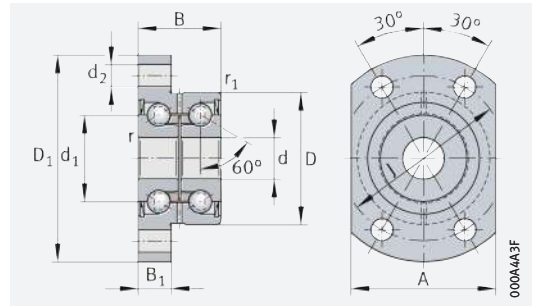

ZKLFA...-2RS, ZKLFA...-2Z

d = 10 – 15 mm

Main dimensions			Dimensions			Designation
d	D	B	d ₁	D ₁	r min.	
10 0/-0,005	32 0/-0,01	20 0/-0,25	21	50	0,3	ZKLFA1050-2RS
	32 0/-0,01	20 0/-0,25	21	50	0,3	ZKLFA1050-2Z
12 0/-0,005	42 0/-0,01	25 0/-0,25	25	63	0,3	ZKLFA1263-2RS
	42 0/-0,01	25 0/-0,25	25	63	0,3	ZKLFA1263-2Z
15 0/-0,005	42 0/-0,01	25 0/-0,25	28	63	0,3	ZKLFA1563-2RS
	42 0/-0,01	25 0/-0,25	28	63	0,3	ZKLFA1563-2Z

d	Basic load ratings axial		Fatigue limit load C _{ua} N	Limiting speed n _{G grease} min ⁻¹	Thermally safe operating speed n _ø min ⁻¹	Bearing frictional torque M _R Nm	Mass m ≈ kg	Designation
	dyn. C _a N	stat. C _{0a} N						
10	13 400	18 800	830	10 900	4 600	0,12	0,18	ZKLFA1050-2RS
	13 400	18 800	830	14 400	8 600	0,06	0,18	ZKLFA1050-2Z
12	16 900	24 700	1 090	9 200	3 800	0,16	0,3	ZKLFA1263-2RS
	16 900	24 700	1 090	12 000	7 600	0,08	0,3	ZKLFA1263-2Z
15	17 900	28 000	1 240	8 200	3 500	0,2	0,31	ZKLFA1563-2RS
	17 900	28 000	1 240	10 800	7 000	0,1	0,31	ZKLFA1563-2Z

medias ► <https://www.schaeffler.de/std/1E5E>

② Adjacent construction, bearing screw mounted on flat surface ④ Only valid in assembled condition.

- 1) Screws 10.9 are not included in the scope of delivery. Tightening torque according to manufacturer's data.
- 2) Based on rotating inner ring.
- 3) The recommended INA precision locknuts are not included in the scope of delivery and must be ordered separately.
- 4) The required axial locknut force must be observed when using other locknuts.
- 5) Only valid in conjunction with INA precision locknuts. Observe the guidelines on locating/locating bearing arrangements ► TPI 123.

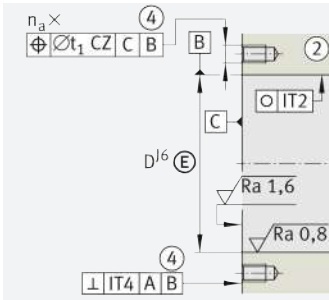

Housing design

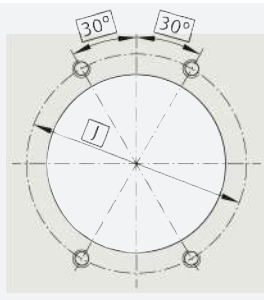

000A449

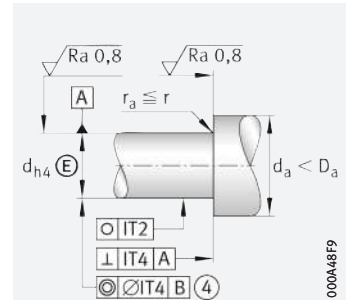

Shaft design
(threaded spindle)

000A48F9

Dimensions						Mounting dimensions			Fixing screws ¹⁾ DIN EN ISO 4762	
d	r ₁ min.	B ₁	d ₂	J	A	d _a		t ₁	Size	n _a
						min.	max.			
10	0,6	8	5,5	40	35	14	27	0,1	M5	4
	0,6	8	5,5	40	35	14	27	0,1	M5	4
12	0,6	10	6,8	53	45	16	31	0,1	M6	4
	0,6	10	6,8	53	45	16	31	0,1	M6	4
15	0,6	10	6,8	53	45	20	34	0,1	M6	4
	0,6	10	6,8	53	45	20	34	0,1	M6	4

d	Rigidity	Tilting rigidity	Mass moment of inertia ²⁾	Axial runout ²⁾	Recommended INA precision locknuts ³⁾			Required locknut force ⁴⁾
	axial				for radial clamping	for axial clamping	Tightening torque ⁵⁾	axial
	c _{aL}	c _{kL}	M _m				M _A	
	N/μm	Nm/mrad	kg · cm ²	μm			Nm	N
10	325	25	0,029	2	ZM10	–	6	4 891
	325	25	0,029	2	ZM10	–	6	4 891
12	375	50	0,068	2	ZM12	–	8	5 307
	375	50	0,068	2	ZM12	–	8	5 307
15	400	65	0,102	2	ZM15	AM15	10	5 484
	400	65	0,102	2	ZM15	AM15	10	5 484



Triple row axial angular contact ball bearings with flange

With fixing holes

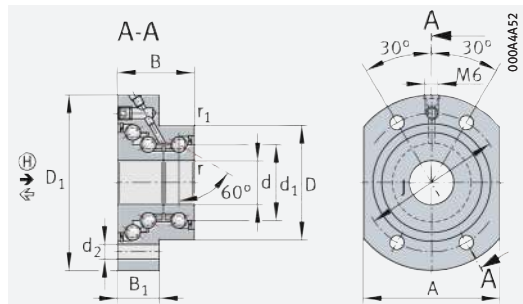

DKLFA...-2RS (d ≤ 20 mm)

d = 15 – 25 mm

Main dimensions			Dimensions			Designation
d	D	B	d ₁	D ₁ min.	r min.	
15	45	32	28	75	0,3	DKLFA1575-2RS
20	52	35	34,5	80	0,3	DKLFA2080-2RS
25	57	38	40,5	90	0,3	DKLFA2590-2RS

d	Basic load ratings				Fatigue limit load		Limiting speed n _G grease min ⁻¹	Thermally safe operating speed n _θ min ⁻¹	Bearing frictional torque M _R Nm	Mass m ≈ kg	Designation
	dyn. C _a N	stat. C _{0a} N	dyn. C _a N	stat. C _{0a} N	C _{ua} N	C _{ua} (H) N					
15	17 900	28 000	37 000	83 000	1 240	2 450	5 700	2 600	0,35	0,53	DKLFA1575-2RS
20	26 000	47 000	44 500	110 000	2 070	2 800	5 000	2 200	0,45	0,7	DKLFA2080-2RS
25	27 500	55 000	53 000	144 000	2 450	3 950	4 400	2 000	0,6	0,9	DKLFA2590-2RS

medias ► <https://www.schaeffler.de/std/1E5F>

Attention!

The bearings require continuous load in the main load direction (H)!

- ④ Only valid in assembled condition. ⑤ Adjacent construction, bearing screw mounted on flat surface.
- ⑥ Bearing centred in adjacent construction.

- 1) Screws 10.9 not included in scope of delivery. Tightening torque according to manufacturer's data.
- 2) Based on rotating inner ring.
- 3) The recommended INA precision locknuts are not included in the scope of delivery and must be ordered separately.
- 4) The required axial locknut force must be observed when using other locknuts.
- 5) Only valid in conjunction with INA precision locknuts in locating/non-locating bearing arrangements and for ① in locating/locating bearing arrangements.
Observe the guidelines on locating/locating bearing arrangements ► □ TPI 123.

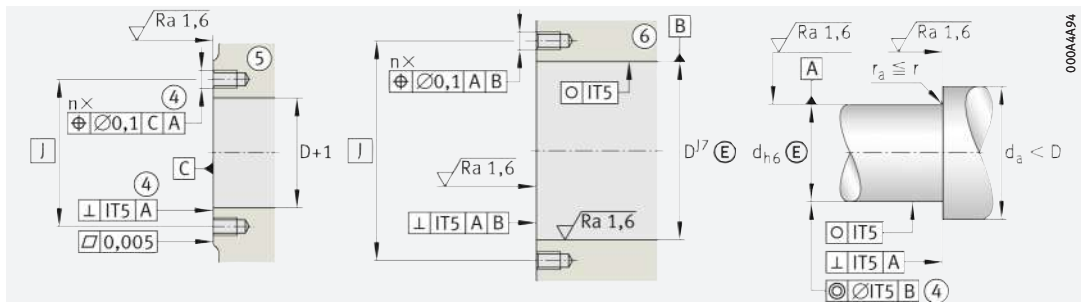

Design of housing and shaft (threaded spindle)

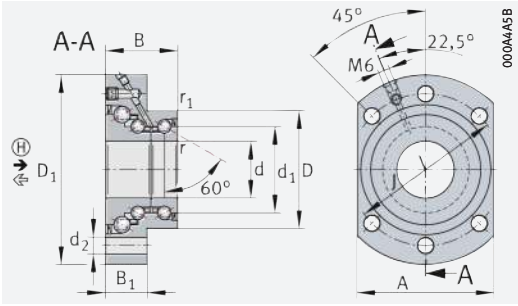

DKLFA...2RS (d ≥ 25 mm)

Dimensions						Mounting dimensions		Fixing screws ¹⁾ DIN EN ISO 4762		
d	r ₁ min.	B ₁	d ₂	J	A	d _a		Size	n	t
						min.	max.			
15	0,6	18	6,8	58	55	20	35	M6	4	60
20	0,6	19	6,8	63	62	25	43	M6	4	60
25	0,6	22	8,8	75	70	32	48	M8	6	45

d	Rigidity		Tilting rigidity	Mass moment of inertia ²⁾	Axial runout ²⁾	Recommended INA precision locknuts ³⁾			Required locknut force ⁴⁾	
	axial ←	axial →				for radial clamping		for axial clamping		Tightening torque ⁵⁾
	c _{aL}	c _{aL}	c _{kL}	M _m	μm	①, ②	③	①, ②	M _A ① Nm	① N
15	500	950	140	0,278	5	ZMA15/33	ZM17	AM15	10	6 270
20	750	1 100	260	0,553	5	ZMA20/38	ZM25	AM20	18	8 580
25	850	1 200	370	1,12	5	ZMA25/45	ZM30	AM25	25	9 670

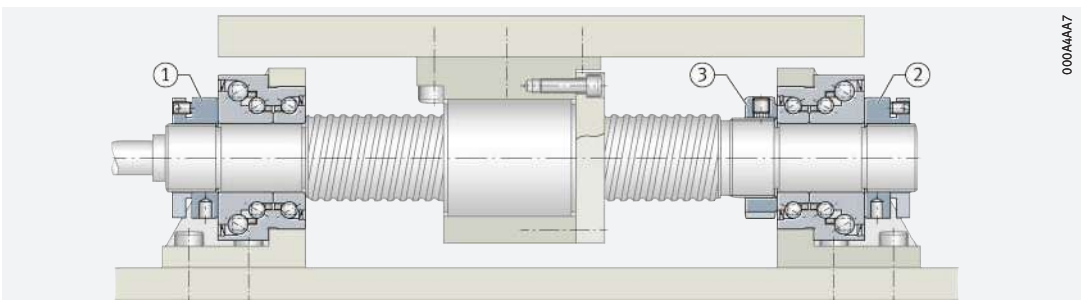

Ball screw drive with locating bearing arrangement on both sides

Triple row angular contact ball bearings with flange

With fixing holes

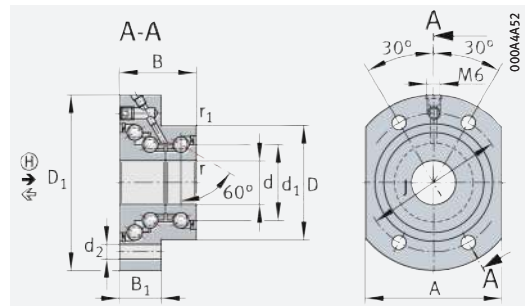

DKLFA...-2RS (d ≤ 20 mm)

d = 30 – 40 mm

Main dimensions			Dimensions			Designation	
d	D	B	d ₁	D ₁ min.	r min.		
30	0 / -0,010	62 0 / -0,013	38 0 / -0,25	45,5	100	0,3	DKLFA30100-2RS
	0 / -0,010	75 0 / -0,013	56 0 / -0,25	51	110	0,3	DKLFA30110-2RS ²⁾
40	0 / -0,010	72 0 / -0,013	42 0 / -0,25	58	115	0,3	DKLFA40115-2RS
	0 / -0,010	90 0 / -0,013	60 0 / -0,25	65	140	0,3	DKLFA40140-2RS ²⁾

d	Basic load ratings				Fatigue limit load		Limiting speed n _G grease min ⁻¹	Thermally safe operating speed n _θ min ⁻¹	Bearing frictional torque M _R Nm	Mass m ≈ kg	Designation
	axial ←	axial →	axial ←	axial →	C _{ua}	C _{ua} (H)					
	dyn. C _a N	stat. C _{0a} N	dyn. C _a N	stat. C _{0a} N	N	N					
30	29 000	64 000	56 000	165 000	2 800	4 450	4 000	1 800	0,75	1	DKLFA30100-2RS
	59 000	108 000	107 000	255 000	4 800	6 600	3 500	1 600	1,5	2,5	DKLFA30110-2RS ²⁾
40	43 000	101 000	73 000	227 000	4 450	5 600	3 200	1 500	1	1,5	DKLFA40115-2RS
	72 000	149 000	127 000	365 000	6 600	9 500	2 900	1 200	2,5	4,2	DKLFA40140-2RS ²⁾

medias ► <https://www.schaeffler.de/std/1E60>

Attention!

The bearings require continuous load in the main load direction (H)!

- ④ Only valid in assembled condition. ⑤ Adjacent construction, bearing screw mounted on flat surface.
- ⑥ Bearing centred in adjacent construction.

- 1) Screws 10.9 not included in scope of delivery. Tightening torque according to manufacturer's data.
- 2) Heavy series.
- 3) Based on rotating inner ring.

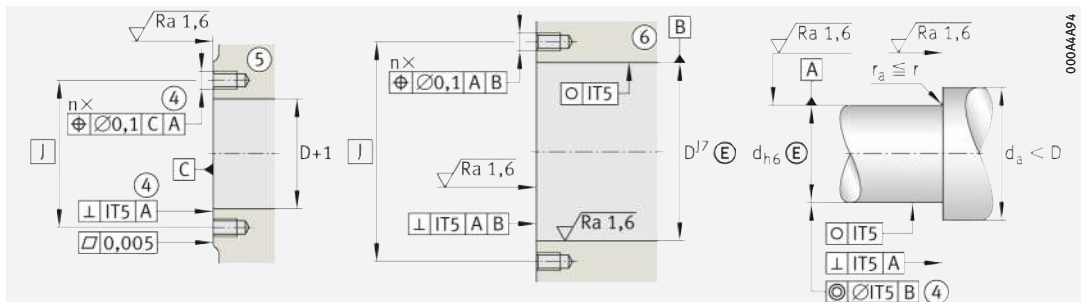

Design of housing and shaft (threaded spindle)

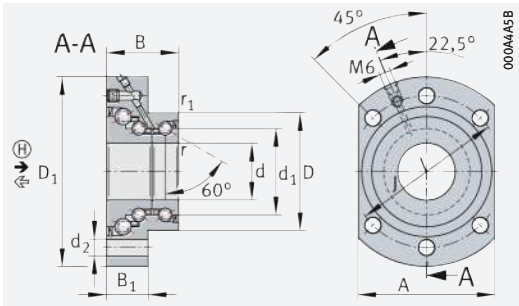

DKLFA..-2RS (d ≥ 25 mm)

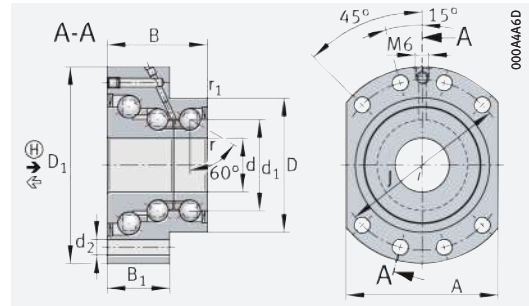

DKLFA..-2RS
Heavy series

Dimensions						Mounting dimensions		Fixing screws ¹⁾ DIN EN ISO 4762		
d	r ₁ min.	B ₁	d ₂	J	A	d _a		Size	n	t
						min.	max.			
30	0,6	22	8,8	80	72	40	53	M8	6	45
	0,6	35	8,8	95	85	47	64	M8	8	30
40	0,6	23	8,8	94	90	50	67	M8	6	45
	0,6	35	11	118	110	56	80	M10	8	30

d	Rigidity		Tilting rigidity	Mass moment of inertia ³⁾	Axial runout ³⁾	Recommended INA precision locknuts ⁴⁾			Required locknut force ⁵⁾	
	axial ←	axial →				for radial clamping		for axial clamping		Tightening torque ⁶⁾
	c _{aL}	c _{aL}	c _{kL}	M _m	①, ②	③	①, ②	M _A ① Nm	① N	
30	900	1 400	500	1,7	5	ZMA30/52	ZM35	AM30	32	10 350
	1 300	1 600	650	3,23	5	–	ZM35	AM30/65	65	20 500
40	1 100	1 700	1 000	4,23	5	ZMA40/62	ZM45	AM40	55	13 420
	1 800	2 000	1 370	9,32	5	–	ZM45	AM40/85	110	26 600

⁴⁾ The recommended INA precision locknuts are not included in the scope of delivery and must be ordered separately.

⁵⁾ The required axial locknut force must be observed when using other locknuts.

⁶⁾ Only valid in conjunction with INA precision locknuts in locating/non-locating bearing arrangements and for ① in locating/locating bearing arrangements. Observe the guidelines on locating/locating bearing arrangements ► [TPI 123](#).

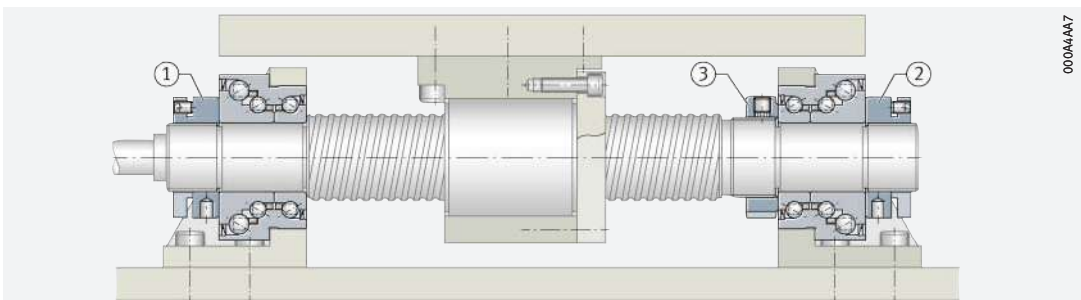

Ball screw drive with locating bearing arrangement on both sides

Needle roller/axial cylindrical roller bearings

Light series
With fixing holes

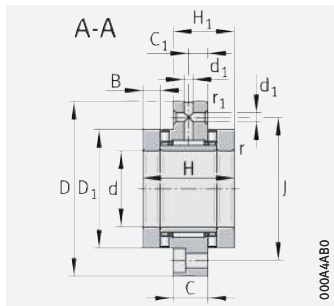

ZARF

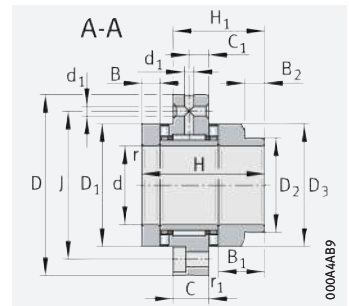

ZARF..-L

d = 15 – 30 mm

Main dimensions	Basic load ratings						Fatigue limit load		Limiting speeds		Bearing frictional torque M_R Nm	Mass m ≈ kg	Designation
	d	D	H	axial		radial		C_{ua}	C_{ur}	n_G oil min ⁻¹			
			dyn. C_{0a} N	stat. C_{0a} N	dyn. C_{0r} N	stat. C_{0r} N	N	N					
15	60	40	24 900	53 000	13 000	17 500	7 300	2 600	8 500	2 200	0,35	0,42	ZARF1560-TV
	60	53	24 900	53 000	13 000	17 500	7 300	2 600	8 500	2 200	0,35	0,45	ZARF1560-L-TV
17	62	43	26 000	57 000	14 000	19 900	7 900	2 950	7 800	2 100	0,4	0,49	ZARF1762-TV
	62	57	26 000	57 000	14 000	19 900	7 900	2 950	7 800	2 100	0,4	0,52	ZARF1762-L-TV
20	68	46	33 500	76 000	14 900	22 400	6 300	3 350	7 000	2 000	0,5	0,56	ZARF2068-TV
	68	60	33 500	76 000	14 900	22 400	6 300	3 350	7 000	2 000	0,5	0,61	ZARF2068-L-TV
25	75	50	35 500	86 000	22 600	36 000	7 100	5 100	6 000	1 900	0,55	0,78	ZARF2575-TV
	75	65	35 500	86 000	22 600	36 000	7 100	5 100	6 000	1 900	0,55	0,84	ZARF2575-L-TV
30	80	50	39 000	101 000	24 300	41 500	8 400	5 900	5 500	1 800	0,65	0,85	ZARF3080-TV
	80	65	39 000	101 000	24 300	41 500	8 400	5 900	5 500	1 800	0,65	0,9	ZARF3080-L-TV

medias ► <https://www.schaeffler.de/std/1E61>

- ① Mounting dimension for seal carrier assembly DRS ► TPI 123.
- ③ Adjacent construction, bearing screw mounted in bore. ④ Only valid in assembled condition.

- 1) If rotary shaft seals are used, the outside diameter of the sealing ring must be taken into consideration.
- 2) Based on rotating inner ring.
- 3) The recommended INA precision locknuts are not included in the scope of delivery and must be ordered separately.
- 4) The required axial locknut force must be observed when using other locknuts.
- 5) Screws not included in scope of delivery. Tightening torque according to manufacturer's data.
- 6) Only valid in conjunction with INA precision locknuts.
Observe the guidelines on locating/locating bearing arrangements ► TPI 123.

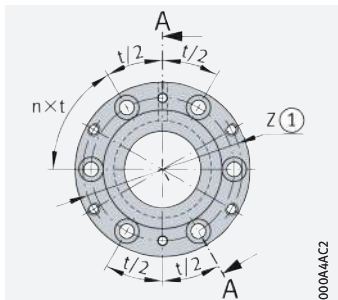

Hole pattern
ZARF1560, ZARF1762

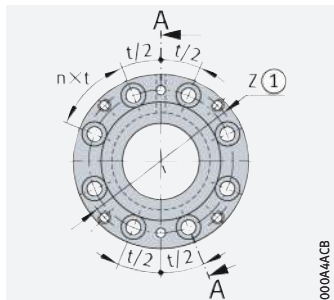

Hole pattern
ZARF2068, ZARF2575

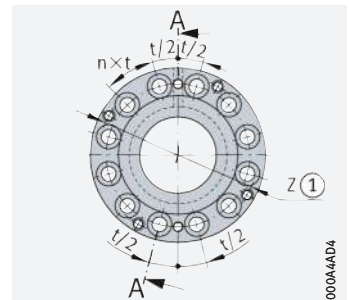

Hole pattern
ZARF3080

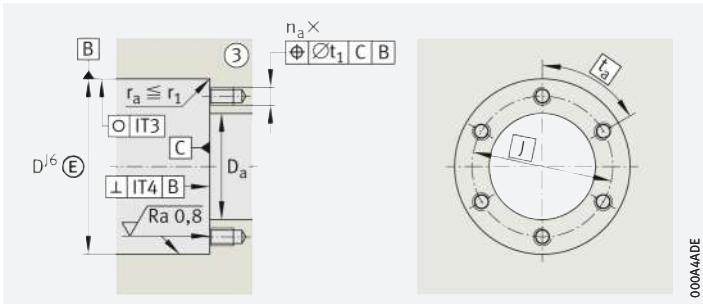

Housing design

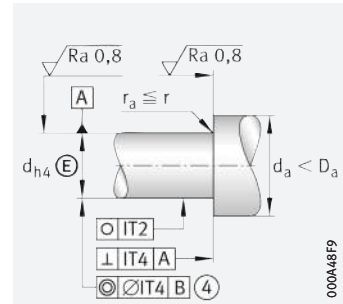

Shaft design (threaded spindle)

Dimensions														Pitch			Mounting dimensions ¹⁾			Mass moment of inertia ²⁾
	d	H ₁	C	C ₁	D ₁	D ₂	D ₃	B	B ₁	B ₂	r	r ₁	d ₁	J	n	t	D _a	d _a	t ₁	M _m
														°	max.	min.		kg · cm ²		
15	26	14	8	35	-	-	7,5	-	-	-	0,3	0,6	3,2	46	6	60	36	28	0,1	0,24
	39	14	8	35	24	34	7,5	20,5	11	0,3	0,6	3,2	46	6	60	36	22	0,1	0,274	
17	27,5	14	8	38	-	-	9	-	-	-	0,3	0,6	3,2	48	6	60	39	28	0,1	0,373
	41,5	14	8	38	28	38	9	23	11	0,3	0,6	3,2	48	6	60	39	26	0,1	0,464	
20	29	14	8	42	-	-	10	-	-	-	0,3	0,6	3,2	53	8	45	43	33	0,1	0,615
	43	14	8	42	30	40	10	24	12	0,3	0,6	3,2	53	8	45	43	28	0,1	0,683	
25	33	18	10	47	-	-	10	-	-	-	0,3	0,6	3,2	58	8	45	48	39	0,1	0,989
	48	18	10	47	36	45	10	25	12	0,3	0,6	3,2	58	8	45	48	34	0,1	1,15	
30	33	18	10	52	-	-	10	-	-	-	0,3	0,6	3,2	63	12	30	53	44	0,1	1,46
	48	18	10	52	40	50	10	25	13	0,3	0,6	3,2	63	12	30	53	38	0,1	1,7	



d	Rigidity	Tilting rigidity	Axial runout ²⁾	Recommended INA precision locknuts ³⁾			Required locknut force ⁴⁾	Rotary shaft seal to DIN 3760; to be ordered separately	Fixing screws ⁵⁾ DIN EN ISO 4762		
	axial			for radial clamping	for axial clamping	Tightening torque ⁶⁾			axial		Size
	C _{aL}	C _{kL}	μm		M _A	N		°			
15	1 400	110	1	ZMA15/33	AM15	10	6 506	-	M6	6	60
	1 400	110	1	ZMA15/33	AM15	10	6 506	24×35×7	M6	6	60
17	1 600	160	1	ZM17	AM17	12	7 078	-	M6	6	60
	1 600	160	1	ZM17	AM17	12	7 078	28×40×7	M6	6	60
20	1 800	230	1	ZMA20/38	AM20	18	8 972	-	M6	8	45
	1 800	230	1	ZMA20/38	AM20	18	8 972	30×42×7	M6	8	45
25	1 900	350	1	ZMA25/45	AM25	25	9 745	-	M6	8	45
	1 900	350	1	ZMA25/45	AM25	25	9 745	36×47×7	M6	8	45
30	2 200	520	1	ZMA30/52	AM30	32	10 662	-	M6	12	30
	2 200	520	1	ZMA30/52	AM30	32	10 662	40×52×7	M6	12	30



Needle roller/axial cylindrical roller bearings

Light series
With fixing holes

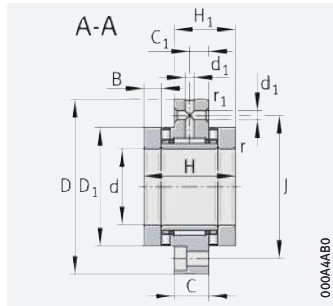

ZARF

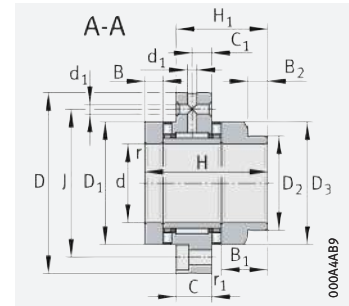

ZARF.-L

d = 35 – 50 mm

Main dimensions	Basic load ratings						Fatigue limit load		Limiting speeds		Bearing frictional torque M _R Nm	Mass m ≈ kg	Designation
	d	D	H	axial		radial		C _{ua}	C _{ur}	n _{G oil}			
			dyn. C _a N	stat. C _{0a} N	dyn. C _r N	stat. C _{0r} N	N	N	min ⁻¹	min ⁻¹			
35	90	54	56 000	148 000	26 000	47 000	12 800	6 700	4 800	1 700	0,9	1,12	ZARF3590-TV
	90	70	56 000	148 000	26 000	47 000	12 800	6 700	4 800	1 700	0,9	1,25	ZARF3590-L-TV
40	100	54	59 000	163 000	27 500	53 000	14 100	7 500	4 400	1 600	1	1,35	ZARF40100-TV
	100	70	59 000	163 000	27 500	53 000	14 100	7 500	4 400	1 600	1	1,45	ZARF40100-L-TV
45	105	60	61 000	177 000	38 000	74 000	15 400	10 200	4 000	1 500	1,2	1,7	ZARF45105-TV
	105	75	61 000	177 000	38 000	74 000	15 400	10 200	4 000	1 500	1,2	1,85	ZARF45105-L-TV
50	115	60	90 000	300 000	40 000	82 000	27 500	11 300	3 600	1 200	2,2	2,1	ZARF50115-TV
	115	78	90 000	300 000	40 000	82 000	27 500	11 300	3 600	1 200	2,2	2,45	ZARF50115-L-TV

medias ► <https://www.schaeffler.de/std/1E62>

- ① Mounting dimension for seal carrier assembly DRS ► □ TPI 123.
- ③ Adjacent construction, bearing screw mounted in bore. ④ Only valid in assembled condition.

- 1) If rotary shaft seals are used, the outside diameter of the sealing ring must be taken into consideration.
- 2) Based on rotating inner ring.
- 3) The recommended INA precision locknuts are not included in the scope of delivery and must be ordered separately.
- 4) The required axial locknut force must be observed when using other locknuts.
- 5) Screws 10.9 not included in scope of delivery. Tightening torque according to manufacturer's data.
- 6) Only valid in conjunction with INA precision locknuts.
Observe the guidelines on locating/locating bearing arrangements ► □ TPI 123.

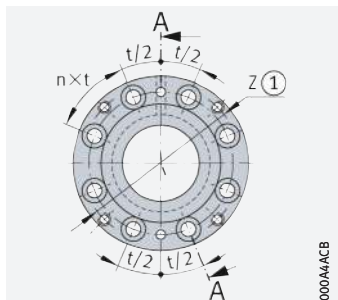

Hole pattern
ZARF40100, ZARF45105

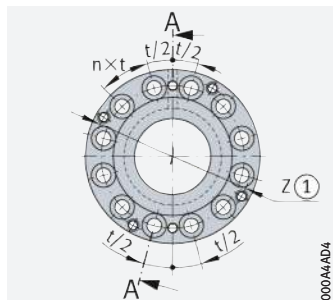

Hole pattern
ZARF3590, ZARF50115

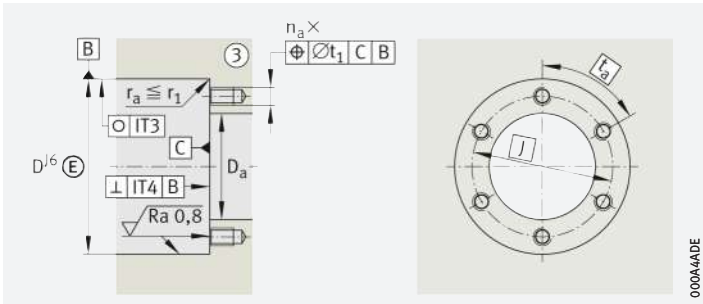

Housing design

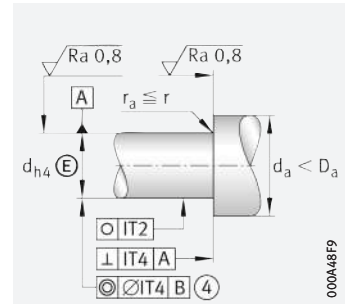

Shaft design (threaded spindle)

Dimensions														Pitch		Mounting dimensions ¹⁾			Mass moment of inertia ²⁾
d	H ₁	C	C ₁	D ₁	D ₂	D ₃	B	B ₁	B ₂	r	r ₁	d ₁	J	n	t	D _a	d _a	t ₁	M _m
										min.	min.				°	max.	min.		kg · cm ²
35	35	18	10	60	–	–	11	–	–	0,3	0,6	3,2	73	12	30	61	50	0,1	2,8
	51	18	10	60	45	58	11	27	13	0,3	0,6	3,2	73	12	30	61	43	0,1	3,21
40	35	18	10	65	–	–	11	–	–	0,3	0,6	3,2	80	8	45	66	55	0,2	3,78
	51	18	10	65	50	63	11	27	14	0,3	0,6	3,2	80	8	45	66	48	0,2	4,35
45	40	22,5	12,5	70	–	–	11,5	–	–	0,3	0,6	6	85	8	45	71	60	0,2	5,33
	55	22,5	12,5	70	56	68	11,5	26,5	13	0,3	0,6	6	85	8	45	71	54	0,2	6,03
50	40	22,5	12,5	78	–	–	11,5	–	–	0,3	0,6	6	94	12	30	79	67	0,2	8,42
	58	22,5	12,5	78	60	78	11,5	29,5	14	0,3	0,6	6	94	12	30	79	58	0,2	10,46



d	Rigidity	Tilting rigidity	Axial runout ²⁾	Recommended INA precision locknuts ³⁾			Required locknut force ⁴⁾	Rotary shaft seal to DIN 3760; to be ordered separately	Fixing screws ⁵⁾ DIN EN ISO 4762			
	axial			for radial clamping	for axial clamping	Tightening torque ⁶⁾			axial	Size	n _a	t _a
	c _{aL}	c _{kL}				M _A						
	N/μm	Nm/mrad	μm			Nm	N					°
35	2 600	740	1	ZMA35/58	AM35/58	40	12 143	–	M6	12	30	
	2 600	740	1	ZMA35/58	AM35/58	40	12 143	45×60×8	M6	12	30	
40	2 800	1 030	1	ZMA40/62	AM40	55	14 240	–	M8	8	45	
	2 800	1 030	1	ZMA40/62	AM40	55	14 240	50×65×8	M8	8	45	
45	3 000	1 340	1	ZMA45/68	AM45	65	15 112	–	M8	8	45	
	3 000	1 340	1	ZMA45/68	AM45	65	15 112	56×70×8	M8	8	45	
50	4 800	2 470	1	ZMA50/75	AM50	85	18 410	–	M8	12	30	
	4 800	2 470	1	ZMA50/75	AM50	85	18 410	60×80×8	M8	12	30	



Needle roller/axial cylindrical roller bearings

Heavy series
With fixing holes

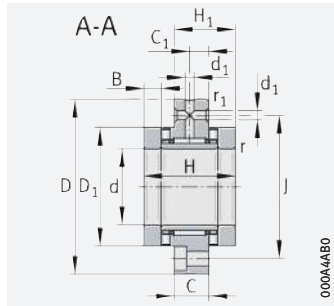

ZARF

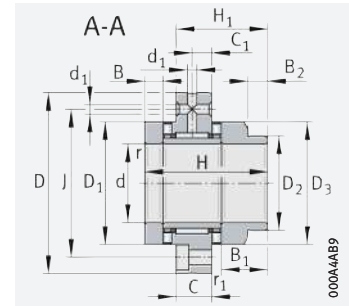

ZARF..L

d = 20 – 45 mm

Main dimensions			Basic load ratings				Fatigue limit load		Limiting speeds		Bearing frictional torque	Mass	Designation
			axial		radial								
d	D	H	dyn. C_a N	stat. C_{0a} N	dyn. C_r N	stat. C_{0r} N	C_{ua} N	C_{ur} N	n_G oil min^{-1}	n_G grease min^{-1}	M_R Nm	m \approx kg	
20	80	60	64 000	141 000	22 600	36 000	12 900	5 100	6 000	1 500	1,3	1,1	ZARF2080-TV
	80	75	64 000	141 000	22 600	36 000	12 900	5 100	6 000	1 500	1,3	1,22	ZARF2080-L-TV
25	90	60	80 000	199 000	24 300	41 500	18 300	5 900	4 900	1 400	1,6	1,6	ZARF2590-TV
	90	75	80 000	199 000	24 300	41 500	18 300	5 900	4 900	1 400	1,6	1,75	ZARF2590-L-TV
30	105	66	107 000	265 000	26 000	47 000	22 500	6 700	4 400	1 300	2,1	1,95	ZARF30105-TV
	105	82	107 000	265 000	26 000	47 000	22 500	6 700	4 400	1 300	2,1	2,15	ZARF30105-L-TV
35	110	66	105 000	265 000	27 500	53 000	22 500	7 500	4 000	1 250	2,3	1,6	ZARF35110-TV
	110	82	105 000	265 000	27 500	53 000	22 500	7 500	4 000	1 250	2,3	1,85	ZARF35110-L-TV
40	115	75	117 000	315 000	38 000	74 000	26 500	10 200	3 700	1 200	2,5	2,7	ZARF40115-TV
	115	93	117 000	315 000	38 000	74 000	26 500	10 200	3 700	1 200	2,5	3	ZARF40115-L-TV
45	130	82	154 000	405 000	40 000	82 000	36 500	11 300	3 300	1 150	3,5	3,9	ZARF45130-TV
	130	103	154 000	405 000	40 000	82 000	36 500	11 300	3 300	1 150	3,5	4,3	ZARF45130-L-TV

medias ► <https://www.schaeffler.de/std/1E63>

- ① Mounting dimension for seal carrier assembly DRS ► \square TPI 123.
- ③ Adjacent construction, bearing screw mounted in bore. ④ Only valid in assembled condition.

- 1) If rotary shaft seals are used, the outside diameter of the sealing ring must be taken into consideration.
- 2) Based on rotating inner ring.
- 3) The recommended INA precision locknuts are not included in the scope of delivery and must be ordered separately.
- 4) The required axial locknut force must be observed when using other locknuts.
- 5) Screws not included in scope of delivery. Tightening torque according to manufacturer's data.
- 6) Only valid in conjunction with INA precision locknuts. Observe the guidelines on locating/locating bearing arrangements ► \square TPI 123.

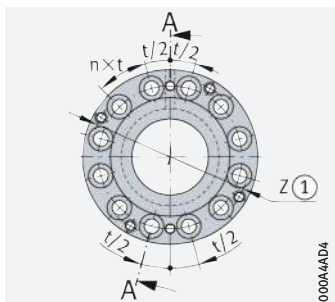

Hole pattern

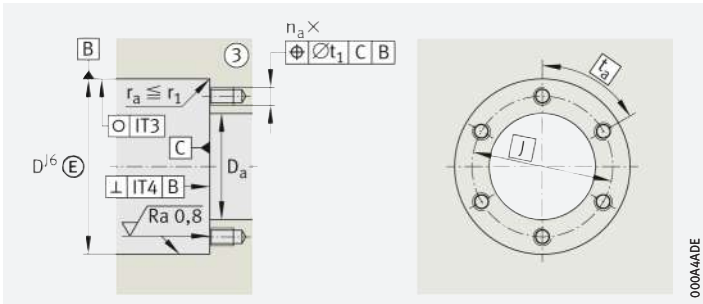

Housing design

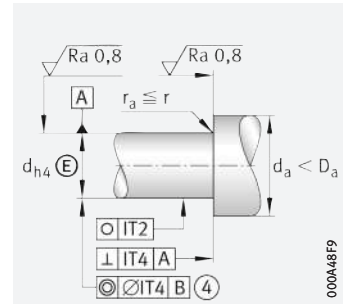

Shaft design (threaded spindle)

Dimensions														Pitch		Mounting dimensions ¹⁾			Mass moment of inertia ²⁾
d	H ₁	C	C ₁	D ₁	D ₂	D ₃	B	B ₁	B ₂	r	r ₁	d ₁	J	n	t	D _a	d _a	t ₁	M _m
										min.	min.				°	max.	min.		kg · cm ²
20	38	18	10	52	–	–	12,5	–	–	0,3	0,6	3,2	63	12	30	53	38	0,1	1,98
	53	18	10	52	40	50	12,5	27,5	13	0,3	0,6	3,2	63	12	30	53	38	0,1	2,27
25	38	18	10	62	–	–	12,5	–	–	0,3	0,6	3,2	73	12	30	63	45	0,1	3,88
	53	18	10	62	48	60	12,5	27,5	13	0,3	0,6	3,2	73	12	30	63	45	0,1	4,51
30	41	18	10	68	–	–	14	–	–	0,3	0,6	3,2	85	12	30	69	52	0,2	6,53
	57	18	10	68	52	66	14	30	13	0,3	0,6	3,2	85	12	30	69	50	0,2	7,43
35	41	18	10	73	–	–	14	–	–	0,3	0,6	3,2	88	12	30	74	60	0,2	8,47
	57	18	10	73	60	73	14	30	13	0,3	0,6	3,2	88	12	30	74	58	0,2	10,4
40	47,5	22,5	12,5	78	–	–	16	–	–	0,3	0,6	6	94	12	30	79	65	0,2	13,3
	65,5	22,5	12,5	78	60	78	16	34	14	0,3	0,6	6	94	12	30	79	58	0,2	15,5
45	51	22,5	12,5	90	–	–	17,5	–	–	0,3	0,6	6	105	12	30	91	70	0,2	23,7
	72	22,5	12,5	90	70	88	17,5	38,5	18	0,3	0,6	6	105	12	30	91	68	0,2	28,1



d	Rigidity		Axial runout ²⁾	Recommended INA precision locknuts ³⁾			Required locknut force ⁴⁾	Rotary shaft seal to DIN 3760; to be ordered separately	Fixing screws ⁵⁾			
	axial	Tilting rigidity		for radial clamping	for axial clamping	Tightening torque ⁶⁾			axial	Size	n _a	t _a
20	2 300	400	1	ZMA20/52	AM20	38	17 623	–	M6	12	30	
	2 300	400	1	ZMA20/52	AM20	38	17 623	40×52×7	M6	12	30	
25	3 000	800	1	ZMA25/58	AM25	55	20 790	–	M6	12	30	
	3 000	800	1	ZMA25/58	AM25	55	20 790	48×62×8	M6	12	30	
30	3 300	1 100	1	ZMA30/65	AM30	75	24 287	–	M8	12	30	
	3 300	1 100	1	ZMA30/65	AM30	75	24 287	52×68×8	M8	12	30	
35	3 500	1 300	1	ZMA35/70	AM35	100	27 480	–	M8	12	30	
	3 500	1 300	1	ZMA35/70	AM35	100	27 480	60×75×8	M8	12	30	
40	3 800	1 800	1	ZMA40/75	AM40	120	29 834	–	M8	12	30	
	3 800	1 800	1	ZMA40/75	AM40	120	29 834	60×80×8	M8	12	30	
45	4 000	2 100	1	ZMA45/85	AM45	150	33 549	–	M8	12	30	
	4 000	2 100	1	ZMA45/85	AM45	150	33 549	70×90×10	M8	12	30	



Needle roller/axial cylindrical roller bearings

Heavy series
With fixing holes

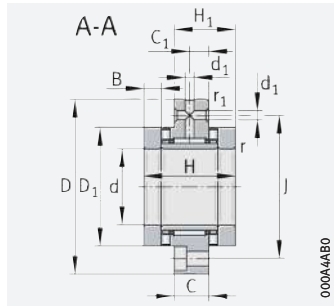

ZARF

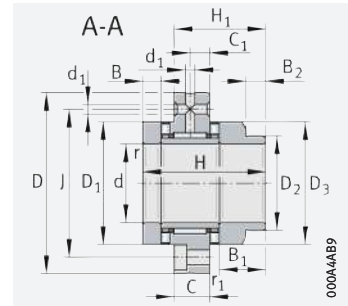

ZARF..L

d = 50 – 65 mm

Main dimensions			Basic load ratings				Fatigue limit load		Limiting speeds		Bearing frictional torque	Mass	Designation
			axial		radial		C_{ua}	C_{ur}	n_G oil	n_G grease			
d	D	H	dyn. C_a N	stat. C_{0a} N	dyn. C_r N	stat. C_{0r} N	N	N	min^{-1}	min^{-1}	M_R Nm	m ≈ kg	
50	140	82	172 000	480 000	41 500	88 000	43 500	12 400	3 100	1 100	3,8	4,2	ZARF50140-TV
	140	103	172 000	480 000	41 500	88 000	43 500	12 400	3 100	1 100	3,8	4,65	ZARF50140-L-TV
55	145	82	177 000	500 000	44 000	98 000	46 000	13 500	2 900	1 000	4	4,5	ZARF55145-TV
	145	103	177 000	500 000	44 000	98 000	46 000	13 500	2 900	1 000	4	5	ZARF55145-L-TV
60	150	82	187 000	550 000	44 500	92 000	50 000	12 600	2 700	950	4,2	4,7	ZARF60150-TV
	150	103	187 000	550 000	44 500	92 000	50 000	12 600	2 700	950	4,2	5,35	ZARF60150-L-TV
65	155	82	172 000	500 000	54 000	104 000	46 000	14 600	2 600	900	4	5,1	ZARF65155-TV
	155	103	172 000	500 000	54 000	104 000	46 000	14 600	2 600	900	4	5,7	ZARF65155-L-TV

medias ► <https://www.schaeffler.de/std/1E64>

- ① Mounting dimension for seal carrier assembly DRS ► □ TPI 123.
- ③ Adjacent construction, bearing screw mounted in bore. ④ Only valid in assembled condition.

- 1) If rotary shaft seals are used, the outside diameter of the sealing ring must be taken into consideration.
- 2) Based on rotating inner ring.
- 3) The recommended INA precision locknuts are not included in the scope of delivery and must be ordered separately.
- 4) The required axial locknut force must be observed when using other locknuts.
- 5) Screws not included in scope of delivery. Tightening torque according to manufacturer's data.
- 6) Only valid in conjunction with INA precision locknuts.
Observe the guidelines on locating/locating bearing arrangements ► □ TPI 123.

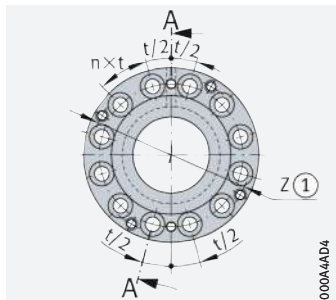

Hole pattern
ZARF5, ZARF6

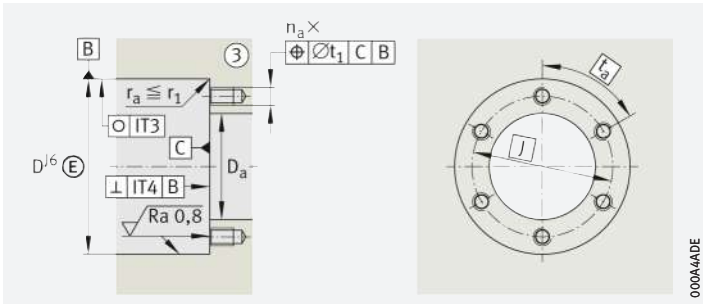

Housing design

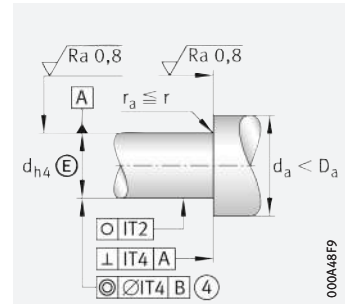

Shaft design (threaded spindle)

Dimensions														Pitch		Mounting dimensions ¹⁾			Mass moment of inertia ²⁾
d	H ₁	C	C ₁	D ₁	D ₂	D ₃	B	B ₁	B ₂	r	r ₁	d ₁	J	n	t	D _a	d _a	t ₁	M _m
										min.	min.				°	max.	min.		kg · cm ²
50	51	22,5	12,5	95	–	–	17,5	–	–	0,3	0,6	6	113	12	30	96	75	0,2	29,8
	72	22,5	12,5	95	75	93	17,5	38,5	18	0,3	0,6	6	113	12	30	96	73	0,2	35,3
55	51	22,5	12,5	100	–	–	17,5	–	–	0,3	0,6	6	118	12	30	101	85	0,2	36,1
	72	22,5	12,5	100	80	98	17,5	38,5	18	0,3	0,6	6	118	12	30	101	78	0,2	43
60	51	22,5	12,5	105	–	–	17,5	–	–	0,3	0,6	6	123	12	30	106	90	0,2	43,8
	72	22,5	12,5	105	90	105	17,5	38,5	18	0,3	0,6	6	123	12	30	106	88	0,2	54,5
65	51	22,5	12,5	110	–	–	17,5	–	–	0,3	0,6	6	128	12	30	111	97	0,2	51
	72	22,5	12,5	110	90	108	17,5	38,5	18	0,3	0,6	6	128	12	30	111	88	0,2	60,1



d	Rigidity	Tilting rigidity	Axial runout ²⁾	Recommended INA precision locknuts ³⁾			Required locknut force ⁴⁾	Rotary shaft seal to DIN 3760; to be ordered separately	Fixing screws ⁵⁾ DIN EN ISO 4762			
	axial			for radial clamping	for axial clamping	Tightening torque ⁶⁾			axial	Size	n _a	t _a
	c _{aL}	c _{kL}				M _A						
	N/μm	Nm/mrad	μm			Nm	N					
50	4 600	2 900	1	ZMA50/92	AM50	180	36 224	–	M10	12	30	
	4 600	2 900	1	ZMA50/92	AM50	180	36 224	75×95×10	M10	12	30	
55	4 900	3 600	1	ZMA55/98	AM55	220	39 807	–	M10	12	30	
	4 900	3 600	1	ZMA55/98	AM55	220	39 807	80×100×10	M10	12	30	
60	5 300	4 300	1	ZMA60/98	AM60	250	41 144	–	M10	12	30	
	5 300	4 300	1	ZMA60/98	AM60	250	41 144	90×110×12	M10	12	30	
65	4 800	4 000	1	ZMA65/105	AM65	270	40 652	–	M10	12	30	
	4 800	4 000	1	ZMA65/105	AM65	270	40 652	90×110×12	M10	12	30	



Needle roller/axial cylindrical roller bearings

Heavy series
With fixing holes

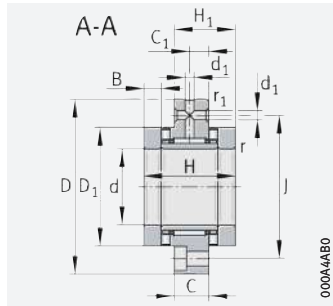

ZARF

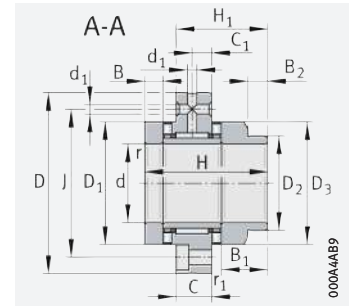

ZARF..-L

d = 70 – 90 mm

Main dimensions	Basic load ratings						Fatigue limit load		Limiting speeds		Bearing frictional torque M _R Nm	Mass m ≈ kg	Designation
	axial		radial				C _{ua}	C _{ur}	n _G oil	n _G grease			
d	D	H	dyn. C _a N	stat. C _{0a} N	dyn. C _r N	stat. C _{0r} N	N	N	min ⁻¹	min ⁻¹			
70	160	82	201 000	630 000	56 000	119 000	57 000	15 800	2 400	800	4,8	5,2	ZARF70160-TV
	160	103	201 000	630 000	56 000	119 000	57 000	15 800	2 400	800	4,8	5,95	ZARF70160-L-TV
75	185	100	290 000	890 000	72 000	132 000	84 000	18 800	2 100	700	8	9,4	ZARF75185-TV
	185	125	290 000	890 000	72 000	132 000	84 000	18 800	2 100	700	8	10,6	ZARF75185-L-TV
90	210	110	325 000	1 030 000	98 000	210 000	93 000	28 500	1 800	700	10,5	13,7	ZARF90210-TV
	210	135	325 000	1 030 000	98 000	210 000	93 000	28 500	1 800	700	10,5	15,1	ZARF90210-L-TV

medias ► <https://www.schaeffler.de/std/1E65>

- ① Mounting dimension for seal carrier assembly DRS ► □ TPI 123.
- ③ Adjacent construction, bearing screw mounted in bore. ④ Only valid in assembled condition.
- 1) If rotary shaft seals are used, the outside diameter of the sealing ring must be taken into consideration.
- 2) Based on rotating inner ring.
- 3) The recommended INA precision locknuts are not included in the scope of delivery and must be ordered separately.
- 4) The required axial locknut force must be observed when using other locknuts.
- 5) Screws not included in scope of delivery. Tightening torque according to manufacturer's data.
- 6) Only valid in conjunction with INA precision locknuts.
Observe the guidelines on locating/locating bearing arrangements ► □ TPI 123.

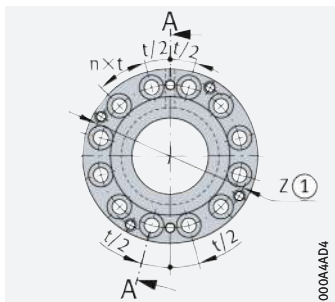

Hole pattern
ZARF7

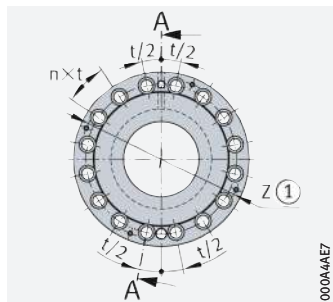

Hole pattern
ZARF90210

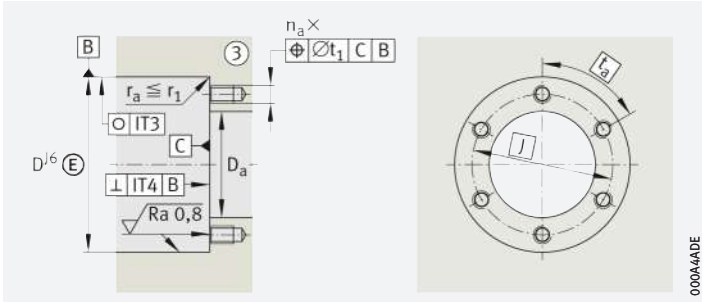

Housing design

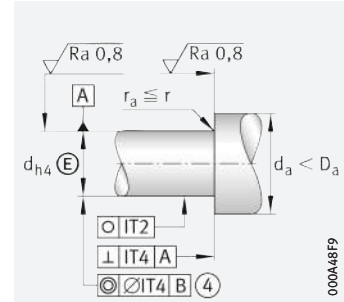

Shaft design (threaded spindle)

Dimensions														Pitch		Mounting dimensions ¹⁾			Mass moment of inertia ²⁾
d	H ₁	C	C ₁	D ₁	D ₂	D ₃	B	B ₁	B ₂	r	r ₁	d ₁	J	n	t	D _a	d _a	t ₁	M _m
										min.	min.				°	max.	min.		kg · cm ²
70	51	22,5	12,5	115	–	–	17,5	–	–	0,3	0,6	6	133	12	30	116	100	0,2	62,2
	72	22,5	12,5	115	100	115	17,5	38,5	18	0,3	0,6	6	133	12	30	116	98	0,2	77,3
75	62	27	15	135	–	–	21	–	–	0,3	1	6	155	12	30	136	113	0,4	149
	87	27	15	135	115	135	21	46	20	0,3	1	6	155	12	30	136	110	0,4	188
90	69,5	32	17,5	160	–	–	22,5	–	–	0,3	1	8	180	16	22,5	161	130	0,4	312
	94,5	32	17,5	160	130	158	22,5	47,5	18	0,3	1	8	180	16	22,5	161	125	0,4	372



d	Rigidity	Tilting rigidity	Axial runout ²⁾	Recommended INA precision locknuts ³⁾			Required locknut force ⁴⁾	Rotary shaft seal to DIN 3760; to be ordered separately	Fixing screws ⁵⁾ DIN EN ISO 4762		
	axial			for radial clamping	for axial clamping	Tightening torque ⁶⁾			axial	Size	n _a
	c _{aL} N/μm	c _{kL} Nm/mrad	μm			M _A Nm	N				°
70	5 800	6 000	1	ZMA70/110	AM70	330	46 786	–	M10	12	30
	5 800	6 000	1	ZMA70/110	AM70	330	46 786	100×120×12	M10	12	30
75	6 600	8 500	2	ZMA75/125	AM75	580	72 971	–	M12	12	30
	6 600	8 500	2	ZMA75/125	AM75	580	72 971	115×140×12	M12	12	30
90	7 700	14 500	2	ZMA90/155	AM90	960	100 669	–	M12	16	22,5
	7 700	14 500	2	ZMA90/155	AM90	960	100 669	130×160×12	M12	16	22,5



Needle roller/axial cylindrical roller bearings

Light series
Without fixing holes

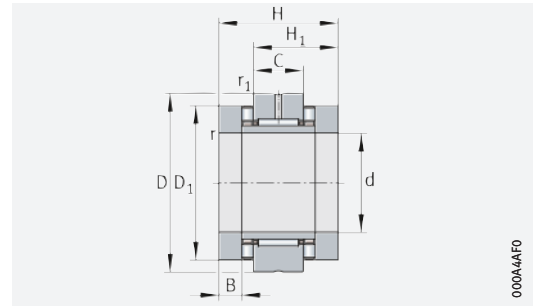

ZARN

000A44F0

d = 15 – 30 mm

Main dimensions			Basic load ratings				Fatigue limit load		Limiting speeds		Bearing frictional torque	Mass	Designation
			axial		radial								
d	D	H	dyn. C _a N	stat. C _{0a} N	dyn. C _r N	stat. C _{0r} N	C _{ua} N	C _{ur} N	n _G oil min ⁻¹	n _G grease min ⁻¹	M _R Nm	m ≈ kg	
15	45	40	24 900	53 000	13 000	17 500	7 300	2 600	8 500	2 200	0,35	0,34	ZARN1545-TV
	45	53	24 900	53 000	13 000	17 500	7 300	2 600	8 500	2 200	0,35	0,37	ZARN1545-L-TV
17	47	43	26 000	57 000	14 000	19 900	7 900	2 950	7 800	2 100	0,4	0,37	ZARN1747-TV
	47	57	26 000	57 000	14 000	19 900	7 900	2 950	7 800	2 100	0,4	0,41	ZARN1747-L-TV
20	52	46	33 500	76 000	14 900	22 400	6 300	3 350	7 000	2 000	0,5	0,41	ZARN2052-TV
	52	60	33 500	76 000	14 900	22 400	6 300	3 350	7 000	2 000	0,5	0,46	ZARN2052-L-TV
25	57	50	35 500	86 000	22 600	36 000	7 100	5 100	6 000	1 900	0,55	0,53	ZARN2557-TV
	57	65	35 500	86 000	22 600	36 000	7 100	5 100	6 000	1 900	0,55	0,59	ZARN2557-L-TV
30	62	50	39 000	101 000	24 300	41 500	8 400	5 900	5 500	1 800	0,65	0,6	ZARN3062-TV
	62	65	39 000	101 000	24 300	41 500	8 400	5 900	5 500	1 800	0,65	0,75	ZARN3062-L-TV

medias ► <https://www.schaeffler.de/std/1E66>

④ Only valid in assembled condition.

- 1) If rotary shaft seals are used, the outside diameter of the sealing ring must be taken into consideration.
- 2) Based on rotating inner ring.
- 3) The recommended INA precision locknuts are not included in the scope of delivery and must be ordered separately.
- 4) The required axial locknut force must be observed when using other locknuts.
- 5) Only valid in conjunction with INA precision locknuts.
Observe the guidelines on locating/locating bearing arrangements ► □ TPI 123.

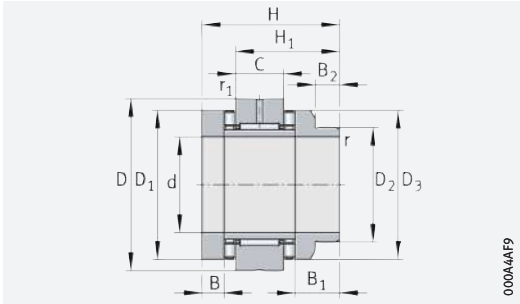

ZARN..-L

000A4AF9

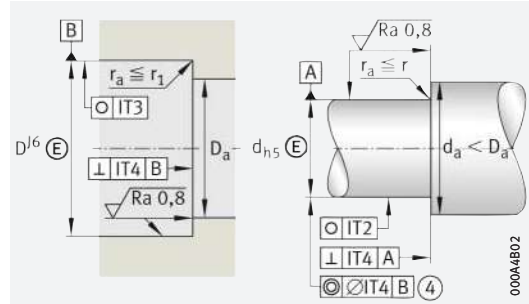

Design of housing and shaft (threaded spindle)

000A4B02

Dimensions

Mounting dimensions¹⁾

d	H ₁	C	D ₁	D ₂	D ₃	B	B ₁	B ₂	r	r ₁	D _a	d _a
15	28	16	35	–	–	7,5	–	–	0,3	0,6	36	28
	41	16	35	24	34	7,5	20,5	11	0,3	0,6	36	22
17	29,5	16	38	–	–	9	–	–	0,3	0,6	39	28
	43,5	16	38	28	38	9	23	11	0,3	0,6	39	26
20	31	16	42	–	–	10	–	–	0,3	0,6	43	33
	45	16	42	30	40	10	24	12	0,3	0,6	43	28
25	35	20	47	–	–	10	–	–	0,3	0,6	48	39
	50	20	47	36	45	10	25	12	0,3	0,6	48	34
30	35	20	52	–	–	10	–	–	0,3	0,6	53	44
	50	20	52	40	50	10	25	13	0,3	0,6	53	38



d	Rigidity		Mass moment of inertia ²⁾ M _m kg · cm ²	Axial runout ²⁾ μm	Recommended INA precision locknuts ³⁾			Required locknut force ⁴⁾ axial N	Rotary shaft seal to DIN 3760; to be ordered separately
	axial C _{aL} N/μm	tilting C _{kL} Nm/mrad			for radial clamping	for axial clamping	Tightening torque ⁵⁾ M _A Nm		
15	1 400	110	0,24	1	ZMA15/33	AM15	10	6 506	–
	1 400	110	0,274	1	ZMA15/33	AM15	10	6 506	24×35×7
17	1 600	160	0,373	1	ZM17	AM17	12	7 078	–
	1 600	160	0,464	1	ZM17	AM17	12	7 078	28×40×7
20	1 800	230	0,615	1	ZMA20/38	AM20	18	8 972	–
	1 800	230	0,683	1	ZMA20/38	AM20	18	8 972	30×42×7
25	1 900	350	0,989	1	ZMA25/45	AM25	25	9 745	–
	1 900	350	1,15	1	ZMA25/45	AM25	25	9 745	36×47×7
30	2 200	520	1,46	1	ZMA30/52	AM30	32	10 662	–
	2 200	520	1,7	1	ZMA30/52	AM30	32	10 662	40×52×7



Needle roller/axial cylindrical roller bearings

Light series
Without fixing holes

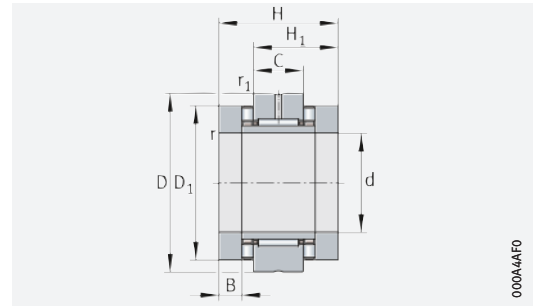

ZARN

000A44FO

d = 35 – 50 mm

Main dimensions			Basic load ratings				Fatigue limit load		Limiting speeds		Bearing frictional torque	Mass	Designation
			axial		radial								
d	D	H	dyn. C _a N	stat. C _{0a} N	dyn. C _r N	stat. C _{0r} N	C _{ua} N	C _{ur} N	n _G oil min ⁻¹	n _G grease min ⁻¹	M _R Nm	m ≈ kg	
35	70	54	56 000	148 000	26 000	47 000	12 800	6 700	4 800	1 700	0,9	0,8	ZARN3570-TV
	70	70	56 000	148 000	26 000	47 000	12 800	6 700	4 800	1 700	0,9	0,93	ZARN3570-L-TV
40	75	54	59 000	163 000	27 500	53 000	14 100	7 500	4 400	1 600	1	0,9	ZARN4075-TV
	75	70	59 000	163 000	27 500	53 000	14 100	7 500	4 400	1 600	1	1	ZARN4075-L-TV
45	80	60	61 000	177 000	38 000	74 000	15 400	10 200	4 000	1 500	1,2	1,12	ZARN4580-TV
	80	75	61 000	177 000	38 000	74 000	15 400	10 200	4 000	1 500	1,2	1,27	ZARN4580-L-TV
50	90	60	90 000	300 000	40 000	82 000	27 500	11 300	3 600	1 200	2,2	1,43	ZARN5090-TV
	90	78	90 000	300 000	40 000	82 000	27 500	11 300	3 600	1 200	2,2	1,78	ZARN5090-L-TV

medias ► <https://www.schaeffler.de/std/1E67>

④ Only valid in assembled condition.

- 1) If rotary shaft seals are used, the outside diameter of the sealing ring must be taken into consideration.
- 2) Based on rotating inner ring.
- 3) The recommended INA precision locknuts are not included in the scope of delivery and must be ordered separately.
- 4) The required axial locknut force must be observed when using other locknuts.
- 5) Only valid in conjunction with INA precision locknuts.
Observe the guidelines on locating/locating bearing arrangements ► TPI 123.

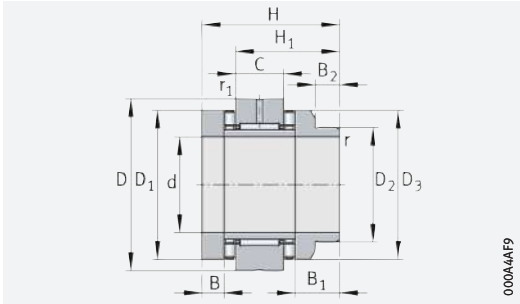

000A44F9

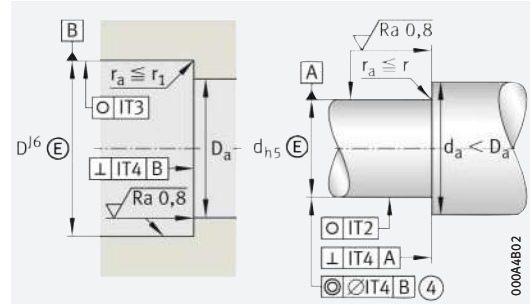

000A4B02

Design of housing and shaft (threaded spindle)

ZARN...-L

Dimensions											Mounting dimensions ¹⁾	
d	H ₁	C	D ₁	D ₂	D ₃	B	B ₁	B ₂	r	r ₁	D _a	d _a
									min.	min.	max.	min.
35	37	20	60	–	–	11	–	–	0,3	0,6	61	50
	53	20	60	45	58	11	27	13	0,3	0,6	61	43
40	37	20	65	–	–	11	–	–	0,3	0,6	66	55
	53	20	65	50	63	11	27	14	0,3	0,6	66	48
45	42,5	25	70	–	–	11,5	–	–	0,3	0,6	71	60
	57,5	25	70	56	68	11,5	26,5	13	0,3	0,6	71	54
50	42,5	25	78	–	–	11,5	–	–	0,3	0,6	79	67
	60,5	25	78	60	78	11,5	29,5	14	0,3	0,6	79	58



d	Rigidity	Tilting rigidity	Mass moment of inertia ²⁾	Axial runout ²⁾	Recommended INA precision locknuts ³⁾			Required locknut force ⁴⁾ axial	Rotary shaft seal to DIN 3760; to be ordered separately
	axial				for radial clamping	for axial clamping	Tightening torque ⁵⁾		
	c _{aL}	c _{kL}	M _m	μm			M _A	N	
	N/μm	Nm/mrad	kg · cm ²				Nm		
35	2 600	740	2,8	1	ZMA35/58	AM35/58	40	12 143	–
	2 600	740	3,21	1	ZMA35/58	AM35/58	40	12 143	45×60×8
40	2 800	1 030	3,78	1	ZMA40/62	AM40	55	14 240	–
	2 800	1 030	4,35	1	ZMA40/62	AM40	55	14 240	50×65×8
45	3 000	1 340	5,33	1	ZMA45/68	AM45	65	15 112	–
	3 000	1 340	6,03	1	ZMA45/68	AM45	65	15 112	56×70×8
50	4 800	2 470	8,42	1	ZMA50/75	AM50	85	18 410	–
	4 800	2 470	10,46	1	ZMA50/75	AM50	85	18 410	60×80×8



Needle roller/axial cylindrical roller bearings

Heavy series
Without fixing holes

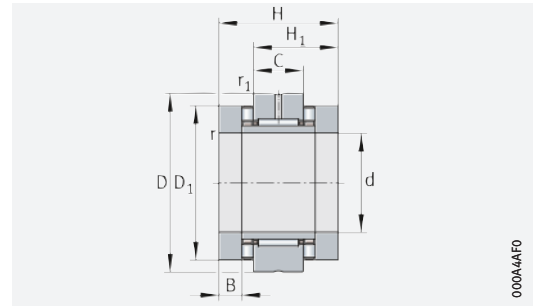

ZARN

000A44FO

d = 20 – 35 mm

Main dimensions			Basic load ratings				Fatigue limit load		Limiting speeds		Bearing frictional torque	Mass	Designation
			axial		radial								
d	D	H	dyn. C _a N	stat. C _{0a} N	dyn. C _r N	stat. C _{0r} N	C _{ua} N	C _{ur} N	n _G oil min ⁻¹	n _G grease min ⁻¹	M _R Nm	m ≈ kg	
20	62	60	64 000	141 000	22 600	36 000	12 900	5 100	6 000	1 500	1,3	0,87	ZARN2062-TV
	62	75	64 000	141 000	22 600	36 000	12 900	5 100	6 000	1 500	1,3	0,99	ZARN2062-L-TV
25	72	60	80 000	199 000	24 300	41 500	18 300	5 900	4 900	1 400	1,6	1,17	ZARN2572-TV
	72	75	80 000	199 000	24 300	41 500	18 300	5 900	4 900	1 400	1,6	1,32	ZARN2572-L-TV
30	80	66	107 000	265 000	26 000	47 000	22 500	6 700	4 400	1 300	2,1	1,5	ZARN3080-TV
	80	82	107 000	265 000	26 000	47 000	22 500	6 700	4 400	1 300	2,1	1,7	ZARN3080-L-TV
35	85	66	105 000	265 000	27 500	53 000	22 500	7 500	4 000	1 250	2,3	1,65	ZARN3585-TV
	85	82	105 000	265 000	27 500	53 000	22 500	7 500	4 000	1 250	2,3	1,8	ZARN3585-L-TV

medias ► <https://www.schaeffler.de/std/1E68>

④ Only valid in assembled condition.

- 1) If rotary shaft seals are used, the outside diameter of the sealing ring must be taken into consideration.
- 2) Based on rotating inner ring.
- 3) The recommended INA precision locknuts are not included in the scope of delivery and must be ordered separately.
- 4) The required axial locknut force must be observed when using other locknuts.
- 5) Only valid in conjunction with INA precision locknuts.
Observe the guidelines on locating/locating bearing arrangements ► □ TPI 123.

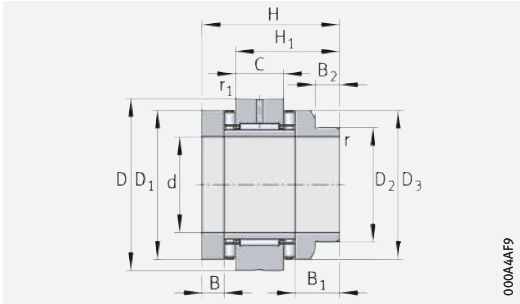

ZARN...-L

000A44F9

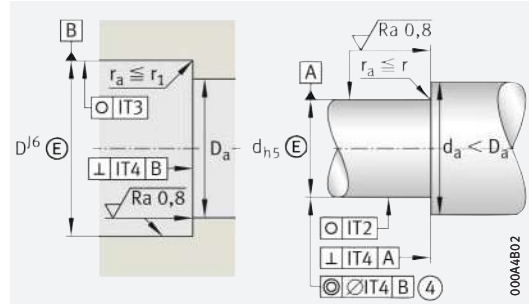

Design of housing and shaft (threaded spindle)

000A4B02

Dimensions

Mounting dimensions¹⁾

d	H ₁	C	D ₁	D ₂	D ₃	B	B ₁	B ₂	r	r ₁	D _a	d _a
20	40	20	52	–	–	12,5	–	–	0,3	0,6	53	38
	55	20	52	40	50	12,5	27,5	13	0,3	0,6	53	38
25	40	20	62	–	–	12,5	–	–	0,3	0,6	63	45
	55	20	62	48	60	12,5	27,5	13	0,3	0,6	63	45
30	43	20	68	–	–	14	–	–	0,3	0,6	69	52
	59	20	68	52	66	14	30	13	0,3	0,6	69	50
35	43	20	73	–	–	14	–	–	0,3	0,6	74	60
	59	20	73	60	73	14	30	13	0,3	0,6	74	58



d	Rigidity	Tilting rigidity	Mass moment of inertia ²⁾ M _m kg · cm ²	Axial runout ²⁾ μm	Recommended INA precision locknuts ³⁾			Required locknut force ⁴⁾ axial N	Rotary shaft seal to DIN 3760; to be ordered separately
	axial c _{aL} N/μm	c _{kL} Nm/mrad			for radial clamping	for axial clamping	Tightening torque ⁵⁾ M _A Nm		
20	2 300	400	1,98	1	ZMA20/52	AM20	38	17 623	–
	2 300	400	2,27	1	ZMA20/52	AM20	38	17 623	40×52×7
25	3 000	800	3,88	1	ZMA25/58	AM25	55	20 790	–
	3 000	800	4,51	1	ZMA25/58	AM25	55	20 790	48×62×8
30	3 300	1 100	6,53	1	ZMA30/65	AM30	75	24 287	–
	3 300	1 100	7,43	1	ZMA30/65	AM30	75	24 287	52×68×8
35	3 500	1 300	8,47	1	ZMA35/70	AM35	100	27 480	–
	3 500	1 300	10,4	1	ZMA35/70	AM35	100	27 480	60×75×8



Needle roller/axial cylindrical roller bearings

Heavy series
Without fixing holes

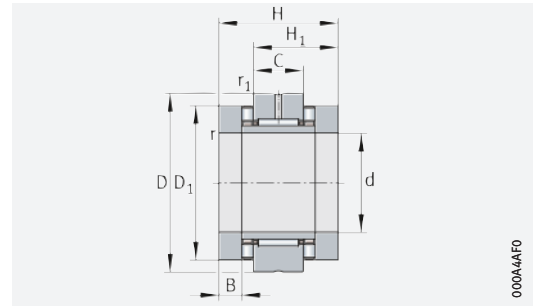

ZARN

000A44FO

d = 40 – 55 mm

Main dimensions			Basic load ratings				Fatigue limit load		Limiting speeds		Bearing frictional torque	Mass	Designation
			axial		radial								
d	D	H	dyn. C _a N	stat. C _{0a} N	dyn. C _r N	stat. C _{0r} N	C _{ua} N	C _{ur} N	n _G oil min ⁻¹	n _G grease min ⁻¹	M _R Nm	m ≈ kg	
40	90	75	117 000	315 000	38 000	74 000	26 500	10 200	3 700	1 200	2,5	2,09	ZARN4090-TV
	90	93	117 000	315 000	38 000	74 000	26 500	10 200	3 700	1 200	2,5	2,39	ZARN4090-L-TV
45	105	82	154 000	405 000	40 000	82 000	36 500	11 300	3 300	1 150	3,5	3,02	ZARN45105-TV
	105	103	154 000	405 000	40 000	82 000	36 500	11 300	3 300	1 150	3,5	3,42	ZARN45105-L-TV
50	110	82	172 000	480 000	41 500	88 000	43 500	12 400	3 100	1 100	3,8	3,3	ZARN50110-TV
	110	103	172 000	480 000	41 500	88 000	43 500	12 400	3 100	1 100	3,8	3,75	ZARN50110-L-TV
55	115	82	177 000	500 000	44 000	98 000	46 000	13 500	2 900	1 000	4	3,5	ZARN55115-TV
	115	103	177 000	500 000	44 000	98 000	46 000	13 500	2 900	1 000	4	4	ZARN55115-L-TV

medias ► <https://www.schaeffler.de/std/1E69>

④ Only valid in assembled condition.

- 1) If rotary shaft seals are used, the outside diameter of the sealing ring must be taken into consideration.
- 2) Based on rotating inner ring.
- 3) The recommended INA precision locknuts are not included in the scope of delivery and must be ordered separately.
- 4) The required axial locknut force must be observed when using other locknuts.
- 5) Only valid in conjunction with INA precision locknuts.
Observe the guidelines on locating/locating bearing arrangements ► □ TPI 123.

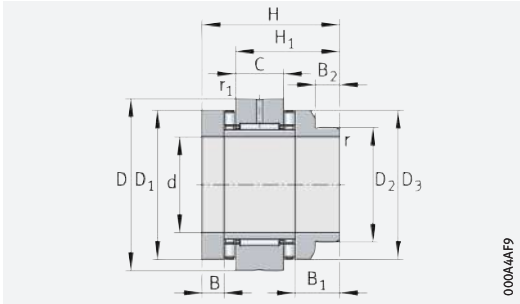

000A44F9

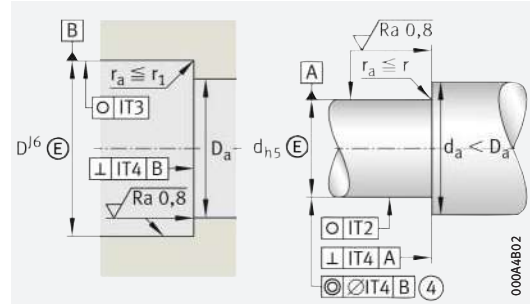

000A4B02

ZARN...-L

Design of housing and shaft (threaded spindle)

Dimensions

Mounting dimensions¹⁾

d	H ₁	C	D ₁	D ₂	D ₃	B	B ₁	B ₂	r	r ₁	D _a	d _a
40	50	25	78	–	–	16	–	–	0,3	0,6	79	65
	68	25	78	60	78	16	34	14	0,3	0,6	79	58
45	53,5	25	90	–	–	17,5	–	–	0,3	0,6	91	70
	74,5	25	90	70	88	17,5	38,5	18	0,3	0,6	91	68
50	53,5	25	95	–	–	17,5	–	–	0,3	0,6	96	75
	74,5	25	95	75	93	17,5	38,5	18	0,3	0,6	96	73
55	53,5	25	100	–	–	17,5	–	–	0,3	0,6	101	85
	74,5	25	100	80	98	17,5	38,5	18	0,3	0,6	101	78



d	Rigidity		Mass moment of inertia ²⁾ M _m kg · cm ²	Axial runout ²⁾ μm	Recommended INA precision locknuts ³⁾			Required locknut force ⁴⁾ axial N	Rotary shaft seal to DIN 3760; to be ordered separately
	axial c _{aL} N/μm	Tilting rigidity c _{kL} Nm/mrad			for radial clamping	for axial clamping	Tightening torque ⁵⁾ M _A Nm		
40	3 800	1 800	13,3	1	ZMA40/75	AM40	120	29 834	–
	3 800	1 800	15,5	1	ZMA40/75	AM40	120	29 834	60×80×8
45	4 000	2 100	23,7	1	ZMA45/85	AM45	150	33 549	–
	4 000	2 100	28,1	1	ZMA45/85	AM45	150	33 549	70×90×10
50	4 600	2 900	29,8	1	ZMA50/92	AM50	180	36 224	–
	4 600	2 900	35,3	1	ZMA50/92	AM50	180	36 224	75×95×10
55	4 900	3 600	36,1	1	ZMA55/98	AM55	220	39 807	–
	4 900	3 600	43	1	ZMA55/98	AM55	220	39 807	80×100×10



Needle roller/axial cylindrical roller bearings

Heavy series
Without fixing holes

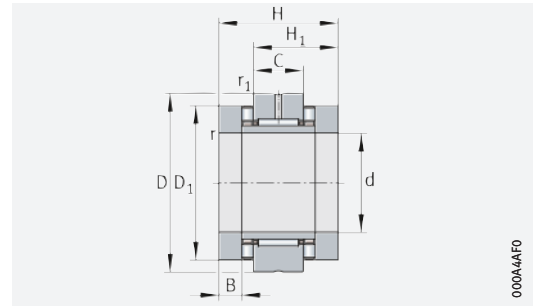

ZARN

000A44FO

d = 60 – 90 mm

Main dimensions	Basic load ratings						Fatigue limit load		Limiting speeds		Bearing frictional torque	Mass	Designation
	axial		radial										
d	D	H	dyn. C _a N	stat. C _{0a} N	dyn. C _r N	stat. C _{0r} N	C _{ua} N	C _{ur} N	n _G oil min ⁻¹	n _G grease min ⁻¹	M _R Nm	m ≈ kg	
60	120	82	187 000	550 000	44 500	92 000	50 000	12 600	2 700	950	4,2	3,7	ZARN60120-TV
	120	103	187 000	550 000	44 500	92 000	50 000	12 600	2 700	950	4,2	4,85	ZARN60120-L-TV
65	125	82	172 000	500 000	54 000	104 000	46 000	14 600	2 600	900	4	4	ZARN65125-TV
	125	103	172 000	500 000	54 000	104 000	46 000	14 600	2 600	900	4	4,6	ZARN65125-L-TV
70	130	82	201 000	630 000	56 000	119 000	57 000	15 800	2 400	800	4,8	4,1	ZARN70130-TV
	130	103	201 000	630 000	56 000	119 000	57 000	15 800	2 400	800	4,8	4,85	ZARN70130-L-TV
75	155	100	290 000	890 000	72 000	132 000	84 000	18 800	2 100	700	8	7,9	ZARN75155-TV
	155	125	290 000	890 000	72 000	132 000	84 000	18 800	2 100	700	8	9,1	ZARN75155-L-TV
90	180	110	325 000	1 030 000	98 000	210 000	93 000	28 500	1 800	700	10,5	11,8	ZARN90180-TV
	180	135	325 000	1 030 000	98 000	210 000	93 000	28 500	1 800	700	10,5	13,2	ZARN90180-L-TV

medias ► <https://www.schaeffler.de/std/1E6A>

④ Only valid in assembled condition.

- 1) If rotary shaft seals are used, the outside diameter of the sealing ring must be taken into consideration.
- 2) Based on rotating inner ring.
- 3) The recommended INA precision locknuts are not included in the scope of delivery and must be ordered separately.
- 4) The required axial locknut force must be observed when using other locknuts.
- 5) Only valid in conjunction with INA precision locknuts.
Observe the guidelines on locating/locating bearing arrangements ► □ TPI 123.

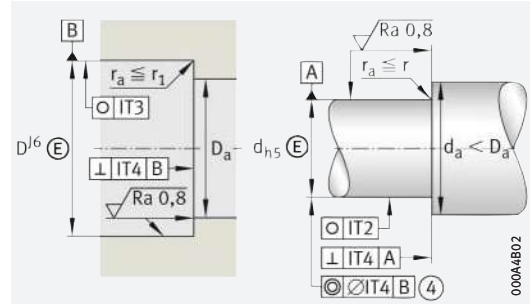
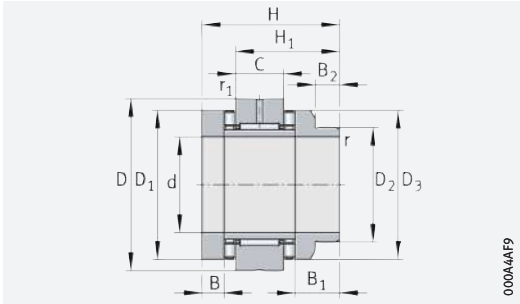

ZARN...-L

Design of housing and shaft (threaded spindle)

Dimensions											Mounting dimensions ¹⁾	
d	H ₁	C	D ₁	D ₂	D ₃	B	B ₁	B ₂	r	r ₁	D _a	d _a
									min.	min.	max.	min.
60	53,5	25	105	–	–	17,5	–	–	0,3	0,6	106	90
	74,5	25	105	90	105	17,5	38,5	18	0,3	0,6	106	88
65	53,5	25	110	–	–	17,5	–	–	0,3	0,6	111	97
	74,5	25	110	90	108	17,5	38,5	18	0,3	0,6	111	88
70	53,5	25	115	–	–	17,5	–	–	0,3	0,6	116	100
	74,5	25	115	100	115	17,5	38,5	18	0,3	0,6	116	98
75	65	30	135	–	–	21	–	–	0,3	1	136	113
	90	30	135	115	135	21	46	20	0,3	1	136	110
90	72,5	35	160	–	–	22,5	–	–	0,3	1	161	130
	97,5	35	160	130	158	22,5	47,5	18	0,3	1	161	125

d	Rigidity	Tilting rigidity	Mass moment of inertia ²⁾	Axial runout ²⁾	Recommended INA precision locknuts ³⁾			Required locknut force ⁴⁾ axial N	Rotary shaft seal to DIN 3760; to be ordered separately
	axial				for radial clamping	for axial clamping	Tightening torque ⁵⁾ M _A Nm		
	c _{aL} N/μm	c _{kL} Nm/mrad	M _m kg · cm ²	μm					
60	5 300	4 300	43,8	1	ZMA60/98	AM60	250	41 144	–
	5 300	4 300	54,5	1	ZMA60/98	AM60	250	41 144	90×110×12
65	4 800	4 000	51	1	ZMA65/105	AM65	270	40 652	–
	4 800	4 000	60,1	1	ZMA65/105	AM65	270	40 652	90×110×12
70	5 800	6 000	62,2	1	ZMA70/110	AM70	330	46 786	–
	5 800	6 000	77,3	1	ZMA70/110	AM70	330	46 786	100×120×12
75	6 600	8 500	149	2	ZMA75/125	AM75	580	72 971	–
	6 600	8 500	188	2	ZMA75/125	AM75	580	72 971	115×140×12
90	7 700	14 500	312	2	ZMA90/155	AM90	960	100 669	–
	7 700	14 500	372	2	ZMA90/155	AM90	960	100 669	130×160×12



Seal carrier assemblies

For ZARF, light series

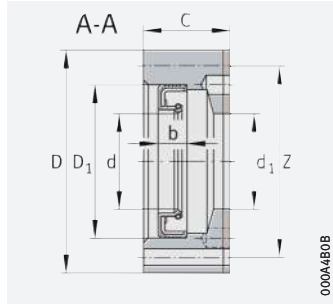

DRS¹⁾

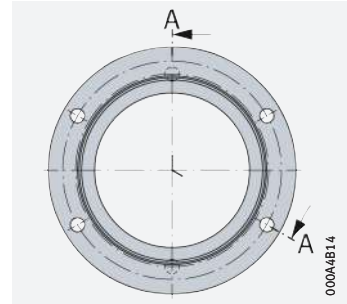

Hole pattern DRS1560, DRS1762

$d_1 = 35 - 78 \text{ mm}$

Main dimensions			Dimension Z	Mass m ≈ kg	Designation	Rotary shaft seal					Matching bearing
d_1	D	C				d	D_1	b	Socket head screws to DIN EN ISO 4762		
			Size	Quantity							
35	60	14	52,4	0,16	DRS1560	35	45	7	M3×20	4	ZARF1560(-L)-TV
38	62	15,5	54,4	0,18	DRS1762	38	47	7	M3×25	4	ZARF1762(-L)-TV
42	68	17	60,4	0,2	DRS2068	42	55	8	M3×25	4	ZARF2068(-L)-TV
47	75	17	67,4	0,22	DRS2575	47	62	6	M3×25	4	ZARF2575(-L)-TV
52	80	17	73,4	0,26	DRS3080	52	68	8	M3×25	4	ZARF3080(-L)-TV
60	90	19	80	0,38	DRS3590	60	72	8	M4×25	4	ZARF3590(-L)-TV
65	100	19	90	0,47	DRS40100	65	80	8	M4×30	4	ZARF40100(-L)-TV
70	105	20	95	0,53	DRS45105	70	85	8	M4×30	4	ZARF45105(-L)-TV
78	115	20	106	0,54	DRS50115	78	100	10	M3×30	4	ZARF50115(-L)-TV

medias ► <https://www.schaeffler.de/std/1E6B>

1) The seal carrier assembly is supplied as a sealing set in individual parts comprising:

- a seal flange
- a rotary shaft seal
- a gasket
- socket head screws.

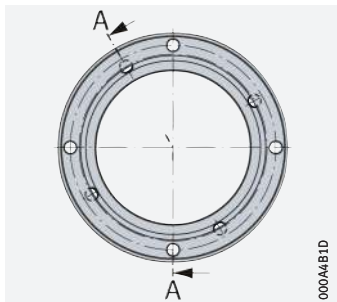

Hole pattern DRS3080, DRS3590, DRS50115

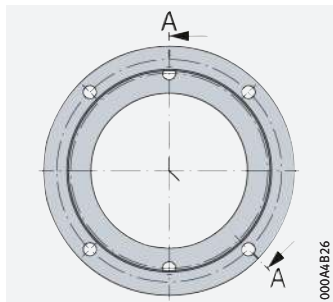

Hole pattern DRS2068, DRS2575, DRS40100, DRS45105



Seal carrier assemblies

For ZARF, heavy series

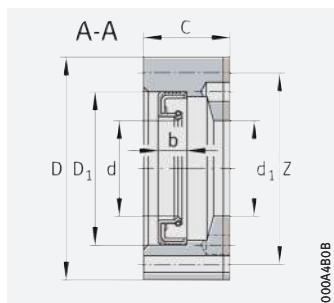

DRS¹⁾

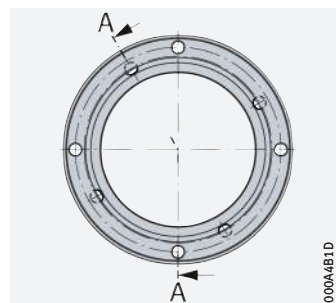

Hole pattern

$d_1 = 52 - 160 \text{ mm}$

Main dimensions			Dimension Z	Mass m ≈ kg	Designation	Rotary shaft seal					Matching bearing
d_1	D	C				d	D_1	b	Socket head screws to DIN EN ISO 4762		
						Size	Quantity				
52	80	22	73,4	0,3	DRS2080	52	68	8	M3×30	4	ZARF2080(-L)-TV
62	90	22	81	0,38	DRS2590	62	75	10	M3×30	4	ZARF2590(-L)-TV
68	105	25	95	0,67	DRS30105	68	85	10	M4×35	4	ZARF30105(-L)-TV
73	110	25	101	0,6	DRS35110	73	95	10	M3×30	4	ZARF35110(-L)-TV
78	115	27,5	106	0,7	DRS40115	78	100	10	M3×35	4	ZARF40115(-L)-TV
90	130	31	120	1,1	DRS45130	90	110	12	M4×40	4	ZARF45130(-L)-TV
95	140	30	127,5	1,4	DRS50140	95	115	13	M5×40	4	ZARF50140(-L)-TV
100	145	30	132,5	1,42	DRS55145	100	120	12	M5×40	4	ZARF55145(-L)-TV
105	150	30	137,5	1,42	DRS60150	105	125	12	M5×40	4	ZARF60150(-L)-TV
110	155	30	142,5	1,43	DRS65155	110	130	12	M5×40	4	ZARF65155(-L)-TV
115	160	30	147,5	1,5	DRS70160	115	135	13	M5×40	4	ZARF70160(-L)-TV
135	185	36	172,5	2,4	DRS75185	135	160	15	M5×50	4	ZARF75185(-L)-TV
160	210	38	194	2,7	DRS90210	160	180	15	M5×50	4	ZARF90210(-L)-TV

medias ► <https://www.schaeffler.de/std/1E6C>

¹⁾ The seal carrier assembly is supplied as a sealing set in individual parts comprising:

- a seal flange
- a rotary shaft seal
- a gasket
- socket head screws.





Precision locknuts

For axial clamping

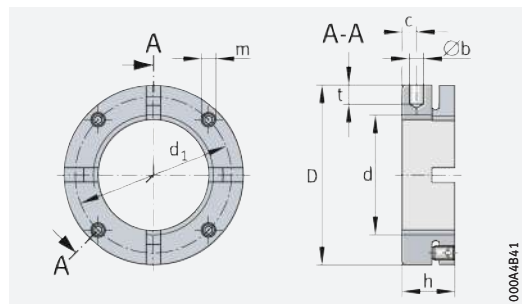

AM15 to AM40 with 4 segments
 AM45 to AM90 with 6 segments
 AM100 to AM130 with 8 segments

d = M15×1 – M130×2

Main dimensions			Grub screw	Locknut ¹⁾				Mass	Designation	Dimensions				
d	D	h		Tightening torque M _A Nm	Axial rupture load F _{aB} N	Break-away torque M _L at M _{AL} Nm	Reference tightening torque Nm			Mass moment of inertia M _M kg · cm ²	m ≈ kg	b H11	t	d ₁
			M15×1					30	18					
M17×1	32	18	3	120 000	25	15	0,11	0,07	AM17	4	5	26	5	M5
M20×1	38	18	5	145 000	45	18	0,23	0,13	AM20	4	6	31	5	M6
M25×1,5	45	20	5	205 000	60	25	0,49	0,16	AM25	5	6	38	6	M6
M30×1,5	52	20	5	250 000	70	32	0,86	0,2	AM30	5	7	45	6	M6
M30×1,5	65	30	5	400 000	70	32	2,8	0,5	AM30/65	6	8	45	6	M6
M35×1,5	58	20	5	280 000	90	40	1,3	0,23	AM35/58	5	7	51	6	M6
M35×1,5	65	22	5	330 000	100	40	2,4	0,33	AM35	6	8	58	6	M6
M40×1,5	65	22	5	350 000	120	55	2,3	0,3	AM40	6	8	58	6	M6
M40×1,5	85	32	5	570 000	120	55	7,6	0,75	AM40/85	6	8	58	6	M6
M45×1,5	70	22	5	360 000	220	65	2,9	0,34	AM45	6	8	63	6	M6
M50×1,5	75	25	5	450 000	280	85	4,3	0,43	AM50	6	8	68	8	M6
M55×2	85	26	15	520 000	320	95	7,7	0,6	AM55	6	8	75	8	M8
M60×2	90	26	15	550 000	365	100	9,4	0,65	AM60	6	8	80	8	M8
M65×2	100	26	15	560 000	400	120	14,6	0,83	AM65	8	10	88	8	M8
M70×2	100	28	15	650 000	450	130	14,7	0,79	AM70	8	10	90	9	M8
M75×2	115	30	20	750 000	610	150	29	1,23	AM75	8	10	102	10	M10
M80×2	110	30	20	670 000	770	160	21,3	0,93	AM80	8	10	98	10	M10
M85×2	115	30	20	690 000	930	180	24,8	0,97	AM85	8	10	102	10	M10
M90×2	130	32	20	900 000	1 100	200	48	1,53	AM90	8	10	118	13	M10
M100×2	130	30	20	740 000	1 200	250	38	1,12	AM100	8	10	118	10	M10
M110×2	140	30	20	770 000	1 300	250	48	1,22	AM110	8	10	128	10	M10
M120×2	155	30	20	880 000	1 450	250	75	1,56	AM120	8	10	142	10	M10
M130×2	165	30	20	900 000	1 600	250	92	1,67	AM130	8	10	152	10	M10

medias ► <https://www.schaeffler.de/std/1E6D>

1) Attention!

If precision locknuts AM are fitted using the socket AMS, a maximum of twice the tightening torque of the bearing is permissible in accordance with the dimension table.



Precision locknuts

For radial clamping

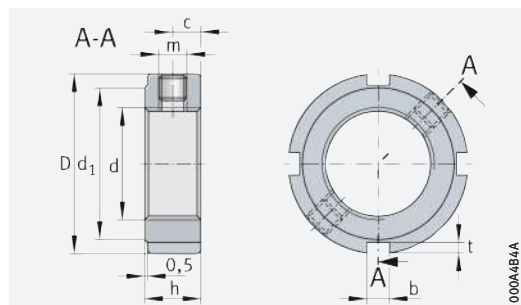

ZM, ZMA

d = M6×0,5 – M55×2

Main dimensions			Grub screw	Locknut				Mass	Designation	Dimensions				
				Tightening torque	Axial rupture load	Break-away torque	Reference tightening torque			Mass moment of inertia	m	b	t	d ₁
d	D	h	M _A Nm	F _{aB} N	M _L at M _{AL} Nm	M _M Nm	M _M kg · cm ²	m ≈ kg						
M6×0,5	16	8	1	17 000	20	2	0,004	0,01	ZM06	3	2	11	4	M4
M8×0,75	16	8	1	23 000	25	4	0,004	0,01	ZM08 ¹⁾	3	2	11	4	M4
M10×1	18	8	1	31 000	30	6	0,006	0,01	ZM10 ¹⁾	3	2	14	4	M4
M12×1	22	8	1	38 000	30	8	0,013	0,015	ZM12	3	2	18	4	M4
M15×1	25	8	1	50 000	30	10	0,021	0,018	ZM15	3	2	21	4	M4
M15×1	33	16	3	106 000	30	10	0,14	0,08	ZMA15/33	4	2	28	8	M5
M17×1	28	10	3	57 000	30	15	0,401	0,028	ZM17	4	2	23	5	M5
M20×1	32	10	3	69 000	40	18	0,068	0,035	ZM20	4	2	27	5	M5
M20×1	38	20	3	174 000	40	18	0,297	0,12	ZMA20/38	5	2	33	10	M5
M20×1	52	25	3	218 000	40	18	1,38	0,32	ZMA20/52	5	2	47	12,5	M5
M25×1,5	38	12	5	90 000	60	25	0,157	0,055	ZM25	5	2	33	6	M6
M25×1,5	45	20	5	211 000	60	25	0,572	0,16	ZMA25/45	5	2	40	10	M6
M25×1,5	58	28	5	305 000	60	25	2,36	0,43	ZMA25/58	6	2,5	52	14	M6
M30×1,5	45	12	5	112 000	70	32	0,304	0,075	ZM30	5	2	40	6	M6
M30×1,5	52	22	5	270 000	70	32	1,1	0,22	ZMA30/52	5	2	47	11	M6
M30×1,5	65	30	5	390 000	70	32	3,94	0,55	ZMA30/65	6	2,5	59	15	M6
M35×1,5	52	12	5	134 000	80	40	0,537	0,099	ZM35	5	2	47	6	M6
M35×1,5	58	22	5	300 000	80	40	1,66	0,26	ZMA35/58	6	2,5	52	11	M6
M35×1,5	70	30	5	460 000	80	40	5,2	0,61	ZMA35/70	6	2,5	64	15	M6
M40×1,5	58	14	5	157 000	95	55	0,945	0,14	ZM40	6	2,5	52	7	M6
M40×1,5	62	22	15	310 000	95	55	2,07	0,27	ZMA40/62	6	2,5	56	11	M8
M40×1,5	75	30	15	520 000	95	55	6,72	0,67	ZMA40/75	6	2,5	69	15	M8
M45×1,5	65	14	5	181 000	110	65	1,48	0,17	ZM45	6	2,5	59	7	M6
M45×1,5	68	24	15	360 000	110	65	3,2	0,35	ZMA45/68	6	2,5	62	12	M8
M45×1,5	85	32	15	630 000	110	65	11,9	0,92	ZMA45/85	7	3	78	16	M8
M50×1,5	70	14	5	205 000	130	85	1,92	0,19	ZM50	6	2,5	64	7	M6
M50×1,5	75	25	15	415 000	130	85	4,89	0,43	ZMA50/75	6	2,5	68	12,5	M8
M50×1,5	92	32	15	680 000	130	85	16,1	1,06	ZMA50/92	8	3,5	84	16	M8
M55×2	75	16	5	229 000	150	95	2,77	0,23	ZM55	7	3	68	8	M6
M55×2	98	32	15	620 000	150	95	20,5	1,17	ZMA55/98	8	3,5	90	16	M8

medias ► <https://www.schaeffler.de/std/1E6E>

¹⁾ When clamped, the grub screw protrudes by ≈ 0,5 mm.



Precision locknuts

For radial clamping

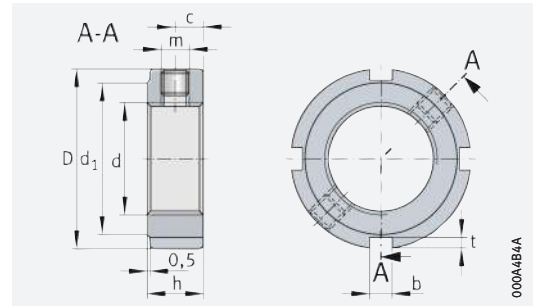

ZM, ZMA

d = M60×2 – M150×2

Main dimensions			Grub screw	Locknut				Mass	Designation	Dimensions				
d	D	h		Tightening torque	Axial rupture load	Break-away torque	Reference tightening torque			Mass moment of inertia	b	t	d ₁	c
			M _A Nm	F _{aB} N	M _L at M _{AL} Nm	Nm	M _M kg · cm ²	m ≈ kg						
M60×2	80	16	5	255 000	180	100	3,45	0,25	ZM60	7	3	73	8	M6
M60×2	98	32	15	680 000	180	100	19,6	1,07	ZMA60/98	8	3,5	90	16	M8
M65×2	85	16	5	280 000	200	120	4,24	0,27	ZM65	7	3	78	8	M6
M65×2	105	32	15	750 000	200	120	25,6	1,21	ZMA65/105	8	3,5	97	16	M8
M70×2	92	18	15	305 000	220	130	6,61	0,36	ZM70	8	3,5	85	9	M8
M70×2	110	35	15	810 000	220	130	33	1,4	ZMA70/110	8	3,5	102	17,5	M8
M75×2	98	18	15	331 000	260	150	8,41	0,4	ZM75	8	3,5	90	9	M8
M75×2	125	38	15	880 000	260	150	62,2	2,11	ZMA75/125	8	3,5	117	19	M8
M80×2	105	18	15	355 000	285	160	11,2	0,46	ZM80	8	3,5	95	9	M8
M80×2	120	35	15	810 000	285	160	44,6	1,33	ZMA80/120	8	4	105	17,5	M8
M85×2	110	18	15	385 000	320	190	13,1	0,49	ZM85	8	3,5	102	9	M8
M90×2	120	20	15	410 000	360	200	21,8	0,7	ZM90	10	4	108	10	M8
M90×2	130	38	15	910 000	360	200	64,1	2,01	ZMA90/130	10	4	120	19	M8
M90×2	155	38	15	1 080 000	360	200	150	3,36	ZMA90/155	10	4	146	19	M8
M100×2	130	20	15	465 000	425	250	28,6	0,77	ZM100	10	4	120	10	M8
M100×2	140	38	20	940 000	425	250	82,8	2,23	ZMA100/140	12	5	128	19	M10
M105×2	140	22	20	495 000	475	300	44,5	1,05	ZM105	12	5	126	11	M10
M110×2	145	22	20	520 000	510	350	50,1	1,09	ZM110	12	5	133	11	M10
M115×2	150	22	20	550 000	550	400	56,2	1,13	ZM115	12	5	137	11	M10
M120×2	155	24	20	580 000	600	450	68,4	1,28	ZM120	12	5	138	12	M10
M125×2	160	24	20	610 000	640	500	76,1	1,33	ZM125	12	5	148	12	M10
M130×2	165	24	20	630 000	700	550	84,3	1,36	ZM130	12	5	149	12	M10
M140×2	180	26	38	690 000	800	600	133	1,85	ZM140	14	6	160	13	M12
M150×2	195	26	38	750 000	900	650	188	2,24	ZM150	14	6	171	13	M12

medias ► <https://www.schaeffler.de/std/1E6F>



Sockets

For precision locknuts with axial clamping

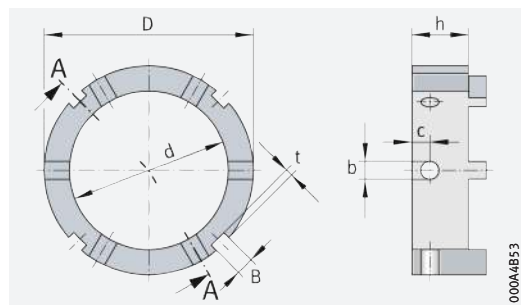

AMS

D = 32 – 155 mm

Main dimensions			Mass m ≈ kg	Designation	Dimensions				For precision locknuts
D	h	d			b	c	B	t	
32	14	22	0,047	AMS20	4	5	4	2	AM15, AM17, AM20
45	15	35	0,093	AMS30	5	5	5	2	AM25, AM30, AM35/58, AM30/65
65	16	45	0,217	AMS40	6	6	6	2,5	AM35, AM40
70	19	53	0,245	AMS50	6	6	6	2,5	AM45, AM50
85	20	65	0,37	AMS60	6	6	7	3	AM55, AM60
98	25	75	0,615	AMS70	8	10	8	3,5	AM65, AM70
110	25	85	0,755	AMS80	8	10	8	3,5	AM75, AM80, AM85
130	25	95	1,215	AMS90	8	10	10	4	AM90
130	25	110	0,74	AMS110	8	10	10	4	AM100, AM110
155	25	130	1,485	AMS130	8	10	12	5	AM120, AM130

medias ► <https://www.schaeffler.de/std/1E70>





Sockets

For precision locknuts suitable for radial or axial clamping
 For torque wrenches
 Suitable for combination with socket AMS

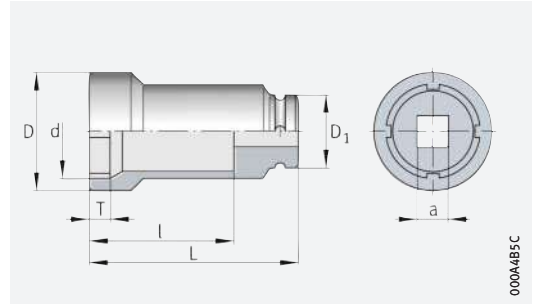

LOCKNUT-SOCKET-KM

000A4B5C

Main dimensions			Mass m ≈ kg	Designation	Dimensions				Suitable for		Suitable in combination with AMS for AM
d	D	a inch			D ₁	L	T	D	Precision locknuts ZM	Sockets AMS	
18,1	22	3/8	0,1	LOCKNUT-SOCKET-KM0	22	57	5	22	ZM10	–	–
22,2	28	3/8	0,1	LOCKNUT-SOCKET-KM1	22	57	5	28	ZM12	–	–
25,2	33	1/2	0,2	LOCKNUT-SOCKET-KM2	30	82	6	33	ZM15	–	–
28,2	36	1/2	0,24	LOCKNUT-SOCKET-KM3	30	82	6	36	ZM17	–	–
32,2	38	1/2	0,28	LOCKNUT-SOCKET-KM4	30	82	9	38	ZM20	AMS20	AM15
32,2	38	1/2	0,28	LOCKNUT-SOCKET-KM4	30	82	9	38	ZM20	AMS20	AM17
32,2	38	1/2	0,28	LOCKNUT-SOCKET-KM4	30	82	9	38	ZM20	AMS20	AM20
38,2	46	1/2	0,38	LOCKNUT-SOCKET-KM5	30	82	9	46	ZMA20/38	–	–
38,2	46	1/2	0,38	LOCKNUT-SOCKET-KM5	30	82	9	46	ZM25	–	–
45,2	53	1/2	0,42	LOCKNUT-SOCKET-KM6	30	82	9	53	ZMA25/45	AMS30	AM25
45,2	53	1/2	0,42	LOCKNUT-SOCKET-KM6	30	82	9	53	ZM30	AMS30	AM30
45,2	53	1/2	0,42	LOCKNUT-SOCKET-KM6	30	82	9	53	–	AMS30	AM35/58
45,2	53	1/2	0,42	LOCKNUT-SOCKET-KM6	30	82	9	53	–	AMS30	AM30/65
52,2	60	1/2	0,45	LOCKNUT-SOCKET-KM7	30	82	9	60	ZMA20/52	–	–
52,2	60	1/2	0,45	LOCKNUT-SOCKET-KM7	30	82	9	60	ZMA30/52	–	–
52,2	60	1/2	0,45	LOCKNUT-SOCKET-KM7	30	82	9	60	ZM35	–	–
58,3	68	1/2	0,61	LOCKNUT-SOCKET-KM8	30	82	9	68	ZMA25/58	–	–
58,3	68	1/2	0,61	LOCKNUT-SOCKET-KM8	30	82	9	68	ZMA35/58	–	–
58,3	68	1/2	0,61	LOCKNUT-SOCKET-KM8	30	82	9	68	ZM40	–	–
65,4	73,5	3/4	0,8	LOCKNUT-SOCKET-KM9	44	90	13,5	73,5	ZMA30/65	–	–
65,4	73,5	3/4	0,8	LOCKNUT-SOCKET-KM9	44	90	13,5	73,5	–	AMS40	AM35
65,4	73,5	3/4	0,8	LOCKNUT-SOCKET-KM9	44	90	13,5	73,5	–	AMS40	AM40
65,4	73,5	3/4	0,8	LOCKNUT-SOCKET-KM9	44	90	13,5	73,5	ZM45	–	–
70,4	78,5	3/4	0,85	LOCKNUT-SOCKET-KM10	44	90	13,5	78,5	ZMA35/70	–	–
70,4	78,5	3/4	0,85	LOCKNUT-SOCKET-KM10	44	90	13,5	78,5	–	AMS50	AM45
70,4	78,5	3/4	0,85	LOCKNUT-SOCKET-KM10	44	90	13,5	78,5	ZM50	AMS50	AM50
75,4	83,5	3/4	0,9	LOCKNUT-SOCKET-KM11	44	90	13,5	83,5	ZMA40/75	–	–
75,4	83,5	3/4	0,9	LOCKNUT-SOCKET-KM11	44	90	13,5	83,5	ZMA50/75	–	–
75,4	83,5	3/4	0,9	LOCKNUT-SOCKET-KM11	44	90	13,5	83,5	ZM55	–	–

medias ► <https://www.schaeffler.de/std/1E71>



Sockets

For precision locknuts suitable for radial or axial clamping

For torque wrenches

Suitable for combination with socket AMS

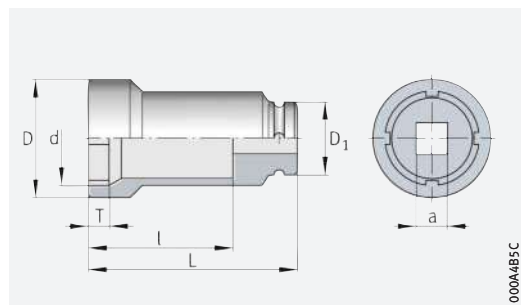

LOCKNUT-SOCKET-KM

000A4B5C

Main dimensions			Mass m ≈ kg	Designation	Dimensions				Suitable for		Suitable in combination with AMS for AM
d	D	a inch			D ₁	L	T	D	Precision locknuts ZM	Sockets AMS	
85,4	94	3/4	1,1	LOCKNUT-SOCKET-KM13	44	90	13,5	94	ZMA45/85	–	–
85,4	94	3/4	1,1	LOCKNUT-SOCKET-KM13	44	90	13,5	94	–	AMS60	AM55
85,4	94	3/4	1,1	LOCKNUT-SOCKET-KM13	44	90	13,5	94	–	AMS60	AM60
85,4	94	3/4	1,1	LOCKNUT-SOCKET-KM13	44	90	13,5	94	ZM65	–	–
92,5	103	1	2,2	LOCKNUT-SOCKET-KM14	76	110	12	103	ZMA50/92	–	–
92,5	103	1	2,2	LOCKNUT-SOCKET-KM14	76	110	12	103	ZM70	–	–
98,5	109	1	2,3	LOCKNUT-SOCKET-KM15	76	110	13	109	ZMA55/98	–	–
98,5	109	1	2,3	LOCKNUT-SOCKET-KM15	76	110	13	109	ZMA60/98	–	–
98,5	109	1	2,3	LOCKNUT-SOCKET-KM15	76	110	13	109	–	AMS70	AM65
98,5	109	1	2,3	LOCKNUT-SOCKET-KM15	76	110	13	109	–	AMS70	AM70
98,5	109	1	2,3	LOCKNUT-SOCKET-KM15	76	110	13	109	ZM75	–	–
105,6	116	1	2,45	LOCKNUT-SOCKET-KM16	76	110	15	116	ZMA65/105	–	–
105,6	116	1	2,45	LOCKNUT-SOCKET-KM16	76	110	15	116	ZM80	–	–
110,6	121	1	2,6	LOCKNUT-SOCKET-KM17	76	110	16	121	ZMA70/110	–	–
110,6	121	1	2,6	LOCKNUT-SOCKET-KM17	76	110	16	121	–	AMS80	AM75
110,6	121	1	2,6	LOCKNUT-SOCKET-KM17	76	110	16	121	–	AMS80	AM80
110,6	121	1	2,6	LOCKNUT-SOCKET-KM17	76	110	16	121	ZM85	AMS80	AM85
120,6	131	1	2,9	LOCKNUT-SOCKET-KM18	76	110	16	131	ZMA80/120	–	–
120,6	131	1	2,9	LOCKNUT-SOCKET-KM18	76	110	16	131	ZM90	–	–
125,6	137	1	3,05	LOCKNUT-SOCKET-KM19	76	110	17	137	ZMA75/125	–	–
130,6	143	1	3,3	LOCKNUT-SOCKET-KM20	76	110	18	143	ZMA90/130	AMS90	AM90
130,6	143	1	3,3	LOCKNUT-SOCKET-KM20	76	110	18	143	ZM100	AMS110	AM100
130,6	143	1	3,3	LOCKNUT-SOCKET-KM20	76	110	18	143	–	AMS110	AM110
115	153	1	3,43	LOCKNUT-SOCKET-KM21	76	110	18	153	ZMA100/140	–	–
115	153	1	3,43	LOCKNUT-SOCKET-KM21	76	110	18	153	ZM105	–	–
120	158	1	3,54	LOCKNUT-SOCKET-KM22	76	110	18	158	ZM110	–	–
130	170	1	4,15	LOCKNUT-SOCKET-KM24	76	110	18	170	ZMA90/155	–	–
130	170	1	4,15	LOCKNUT-SOCKET-KM24	76	110	18	170	ZM120	AMS130	AM120
130	170	1	4,15	LOCKNUT-SOCKET-KM24	76	110	18	170	–	AMS130	AM130

medias ► <https://www.schaeffler.de/std/1E72>



3 Bearings for combined loads

3.1 General features

🔗 Design variants

Bearings for combined loads are available as:

- axial/radial bearings ▶ 1353 | 📄 1
- axial angular contact ball bearings ▶ 1353 | 📄 2
- axial/radial bearings with incremental angular measuring system, with pitch-coded reference marks ▶ 1354 | 📄 3
- axial/radial bearings with absolute value angular measuring system ▶ 1355 | 📄 4.

Product catalogue



The standard range of these bearings is described in detail in Technical Product Information ▶ 📄 TPI 120, High Precision Bearings for Combined Loads, and in our electronic product catalogue **medias professional**.

🔗 Downloading TPI 120

Technical Product Information TPI 120 is available from Schaeffler at ▶ <https://www.schaeffler.de/std/1D5B>.

🔗 medias

The following link will take you to the Schaeffler electronic product selection and information system: ▶ <https://medias.schaeffler.com>.

🔗 App for services

The app “PrecisionDesk” offers extensive services for rotary and linear bearings of a super precision design and assists fitters and engineers in the selection and mounting of bearings. Further information on PrecisionDesk ▶ 1374, download ▶ <https://www.schaeffler.de/std/1D59>.

3.2 Axial/radial bearings, axial angular contact ball bearings

Axial/radial bearings YRT, YRTC and YRTS and axial angular contact ball bearings ZKLDF are ready-to-fit high precision bearings for high precision applications with combined loads. They can support radial loads, axial loads from both sides and tilting moments without clearance and are particularly suitable for bearing arrangements with high requirements for running accuracy.

🔗 Simple mounting due to fixing holes

Due to the fixing holes in the bearing rings, mounting of the units is very simple. After mounting, the bearings are radially and axially preloaded. The mounting dimensions of all series are identical.

Axial/radial bearings YRT, YRTC and YRTS

Axial/radial bearings are double direction axial bearings for screw mounting, with a radial guidance bearing. These ready-to-fit, greased units are very rigid, have high load carrying capacity and run with particularly high accuracy. They can support radial forces, axial forces from both directions and tilting moments free from clearance. The bearings are available in several series ►1353| 1.

1 Axial/radial bearings

F_r = radial load
 F_a = axial load
 M = tilting moment

- ① For standard applications (YRT, YRTC)
- ② For high speeds (YRTS)

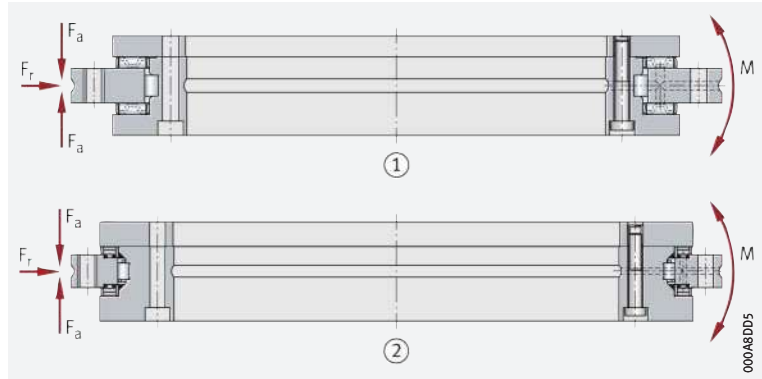

☞ YRT and YRTC suitable for low speeds and small operating durations

☞ YRTS suitable for high speeds with low frictional torque

For standard applications with low speeds and small operating durations, such as indexing tables and swivel type milling heads, the most suitable bearings are series YRT and YRTC.

For the bearing arrangements of direct drive axes, there is the series YRTS. Due to their high limiting speeds and very low, uniform frictional torque across the whole speed range, these bearings are particularly suitable for combination with torque motors.

For higher running accuracy requirements, both series are also available with restricted axial and radial runout.

Axial angular contact ball bearings ZKLDF

☞ Suitable for very high speeds and long operating durations

Axial angular contact ball bearings ZKLDF are highly suitable for high speed applications with long operating duration ►1353| 2.

They are characterised by high tilting rigidity, low friction and low lubricant consumption.

2 Axial angular contact ball bearing ZKLDF

F_r = radial load
 F_a = axial load
 M = tilting moment

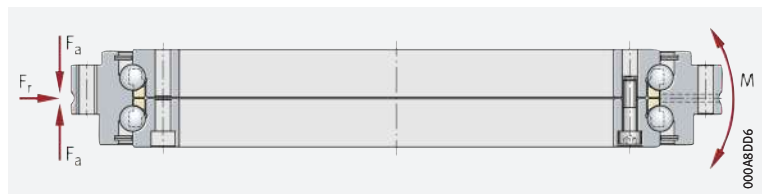

☞ Preferred areas of use

Axial angular contact ball bearings are particularly suitable for precision applications involving combined loads. Their preferred areas of use are bearing arrangements in rotary tables with a main spindle function, for example in combined milling and turning, as well as in milling, grinding and honing heads and in measurement and testing equipment.

3.3 Axial/radial bearings with incremental angular measuring system

Features Axial/radial bearings with an incremental angular measuring system and pitch-coded reference marks comprise an axial/radial bearing YRTCM or YRTSM, each with a dimensional scale, an SRM electronic measuring system and signal leads SRMC ▶ 1354 | 3. The electronic measuring system SRM comprises two measuring heads, two stacks of shims and an electronic evaluation system ▶ 1354 | 3. The signal leads for connecting the measuring heads to the electronic evaluation system can be ordered individually in various designs.

Equivalent in mechanical terms to series YRT and YRTS

Bearings of series YRTM or YRTSM correspond in mechanical terms to axial/radial bearings YRT or YRTS, but are additionally fitted with a magnetic dimensional scale. The measuring system can measure angles to an accuracy of a few angular seconds by non-contact, magneto-resistive means.

3
Axial/radial bearing with incremental angular measuring system

- ① Measuring heads with shims
- ② Connection cable SRMC
- ③ Electronic evaluation system



Advantages of the angular measuring system

The measuring system:

- allows, due to the rigid connection to the adjacent construction, very good control characteristics (control stability and dynamics) and is therefore particularly suitable for axes with torque motor drive
- offers a high maximum measuring speed of up to 16,5 m/s
- operates by non-contact means and is therefore not subject to wear
- carries out measurement irrespective of tilting and position
- has automatically self-adjusting electronics
- has a self-centring function
- is unaffected by lubricants
- is easy to fit, the measuring heads are easily adjustable, there is no need for alignment of the bearing and a separate measuring system
- requires no additional parts
 - the dimensional scale and measuring heads are integrated in the bearings and adjacent construction respectively
 - the resulting space saved can be used for the machining area of the machine
- does not give any problems relating to supply cables. The cables can be laid within the adjacent construction directly through the large bearing bore
- gives savings on components, overall design envelope and costs due to the compact, integrated design requiring fewer components.

3.4 Axial/radial bearings with absolute value angular measuring system

Equivalent in mechanical terms to series YRT and YRTS

Axial/radial bearings with absolute value angular measuring system YRTCMA and YRTSMA correspond in mechanical terms to series YRT and YRTS, but are additionally fitted with an absolute value angular measuring system ▶ 1355 | 4.



4
Axial/radial bearing with absolute value angular measuring system



High system measuring accuracy of angular measuring systems integrated in the bearing

The ideal location for mounting a measuring system is directly in the bearing arrangement, which means that higher system accuracies can be achieved with measuring systems integrated in the bearing than with measuring systems that are attached to the axis a significant distance from the relevant bearing arrangement. The very precise radial runout of the precision rotary axis bearing YRT(S)MA is utilised here.

The absolute angular measuring system integrated directly in the bearing offers considerable advantages:

- an absolute interface, dispensing with the need for reference travel
- a hollow shaft design, freeing up the centre of the machine for other components
- the facility for highly dynamic and precise control loops
- savings in terms of design envelope
- simplifications in design and mounting
- resistance to environmental influences, lubricants and cooling lubricants.

Inductive measurement method ABSYS (AMO)

The inductive measurement method ABSYS (AMO) is based on contact-free scanning of a structured dimensional scale that is applied directly as a measurement ring to the bearing inner ring ▶ 1356 | 5. The irregular structure with absolute coding is captured on a bitwise inductive basis by a coil arrangement that is integrated in the measuring head.

The binary value obtained, which occurs only once per angular position within the entire measurement range, is converted into an absolute angular value by a microcontroller using a conversion table.



The electronic evaluation system is integrated in the measuring head, so the system can be connected directly to the controller. The measuring head is configured such that no adjustment of the measurement gap is required and the rolling bearing chamber is protected against the egress and ingress of lubricants and other media. Other measuring head designs are available by agreement.

5 Absolute value angular measuring system

- ① Measuring head
- ② Measurement ring
- ③ Inner ring of axial/radial bearing

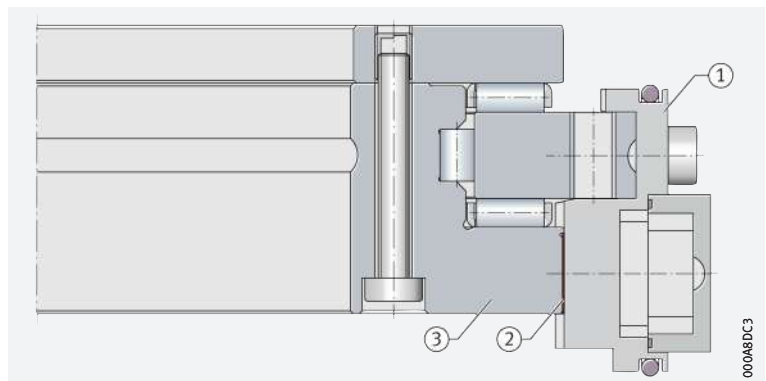





Axial/radial bearings

Double direction

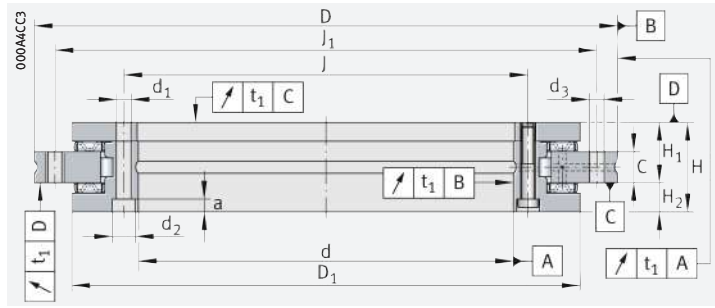

YRT

d = 50 – 180 mm

Main dimensions			Basic load ratings				Fatigue limit load		Limiting speed ¹⁾	Mass	Designation
d	D	H	axial		radial		axial	radial			
			dyn. C _a kN	stat. C _{0a} kN	dyn. C _r kN	stat. C _{0r} kN	C _{ua} kN	C _{ur} kN	n _G min ⁻¹	m ≈ kg	
50	126	30	56	280	28,5	49,5	29,5	7,1	440	1,6	YRT50
80	146	35	38	158	44	98	14,1	13,9	350	2,4	YRT80-TV ⁶⁾
100	185	38	73	370	52	108	35,5	14,7	280	4,1	YRT100
120	210	40	80	445	70	148	40,5	19,1	230	5,3	YRT120
150	240	40	85	510	77	179	44	21,9	210	6,2	YRT150
180	280	43	92	580	83	209	48,5	24,4	190	7,7	YRT180

medias ► <https://www.schaeffler.de/std/1F23>

① Two retaining screws; ② Screw counterbores open (in the L-section ring to the bearing bore), bearing inside diameter is unsupported in this area

- 1) For high operating durations or continuous operation, please contact us.
- 2) Including retaining screws or threaded extraction holes.
- 3) Diameter of inner ring for design of adjacent construction.
- 4) Attention!
For fixing holes in the adjacent construction. Observe the pitch of the bearing holes.
- 5) Tightening torque for screws to DIN EN ISO 4762, grade 10.9.
- 6) Cages made from glass fibre reinforced polyamide 66.
- 7) M5 screws (on inner ring) to 8,5 Nm and M4 screws (on outer ring) to 4,5 Nm.
- 8) Rigidity values taking account of the rolling element set, the deformation of the bearing rings and the screw connections.
For explanations ► □ TPI 120.

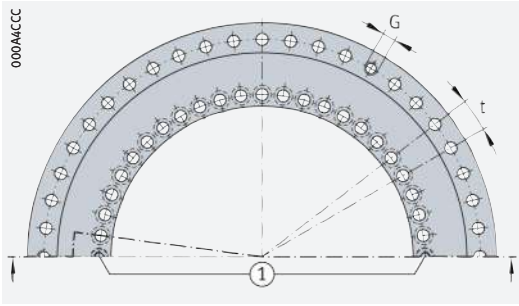

Hole pattern

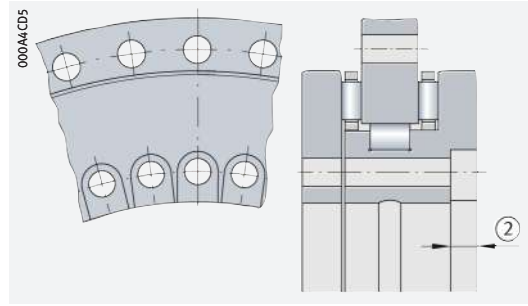

For YRT80-TV and YRT100

Dimensions							Fixing holes					Pitch ²⁾		Threaded extraction hole		Screw tightening torque	
d	H ₁	H ₂	C	D ₁ ³⁾ max.	J	J ₁	Inner ring			Outer ring		n	t	G	Quantity	M _A ⁵⁾ Nm	
							d ₁	d ₂	a	Quantity ⁴⁾	d ₃						Quantity ⁴⁾
50	20	10	10	105	63	116	5,6	–	–	10	5,6	12	12	30	–	0	8,5
80	23,35	11,65	12	130	92	138	5,6	10	4	10	4,6	12	12	30	–	0	8,5 ⁷⁾
100	25	13	12	161	112	170	5,6	10	5,4	16	5,6	15	18	20	M5	3	8,5
120	26	14	12	185	135	195	7	11	6,2	22	7	21	24	15	M8	3	14
150	26	14	12	214,5	165	225	7	11	6,2	34	7	33	36	10	M8	3	14
180	29	14	15	245,1	194	260	7	11	6,2	46	7	45	48	7,5	M8	3	14



d	Designation	Rigidity					
		Bearing position ⁸⁾			Rolling element set		
		axial c _{aL} kN/μm	radial c _{rL} kN/μm	Tilting rigidity c _{kL} kNm/mrad	axial c _{aL} kN/μm	radial c _{rL} kN/μm	Tilting rigidity c _{kL} kNm/mrad
50	YRT50	1,3	1,1	1,25	6,2	1,5	5,9
80	YRT80-TV ⁶⁾	1,6	1,8	2,5	4	2,6	6,3
100	YRT100	2	2	5	6,8	2,4	15
120	YRT120	2,1	2,2	7	7,8	3,8	24
150	YRT150	2,3	2,6	11	8,7	4,6	38
180	YRT180	2,6	3	17	9,9	5,3	57



Axial/radial bearings

Double direction

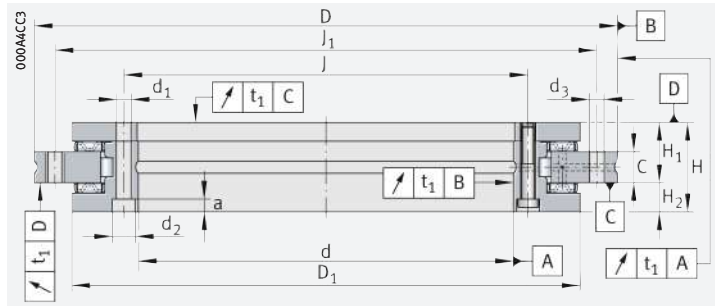

YRTC

d = 200 – 1 030 mm

Main dimensions				Basic load ratings				Fatigue limit load		Limiting speed		Mass	Designation	
d	D	H	axial		radial		axial	radial	Continuous operation n_G min^{-1}	Swivel type operation ²⁾ n_G min^{-1}				
			dyn. C_a kN	stat. C_{0a} kN	dyn. C_r kN	stat. C_{0r} kN	C_{ua} kN	C_{ur} kN						
200	0/-0,015	300	0/-0,018	45	147	850	123	275	62	31,5	450	-	9,2	YRTC200-XL
260	0/-0,018	385	0/-0,02	55	168	1090	140	355	74	37,5	300	-	17,8	YRTC260-XL
325	0/-0,023	450	0/-0,023	60	248	1900	183	530	130	49	200	-	24,7	YRTC325-XL
395	0/-0,023	525	0/-0,028	65	265	2190	200	640	143	56	150	-	32,5	YRTC395-XL
460	0/-0,023	600	0/-0,028	70	288	2550	267	880	160	77	150	-	45,2	YRTC460-XL
580	0/-0,025	750	0/-0,035	90	577	4450	235	730	255	62	80	200	89	YRTC580-XL
650	0/-0,038	870	0/-0,05	122	916	6800	458	1300	405	108	70	170	170	YRTC650-XL
850	0/-0,05	1095	0/-0,063	124	900	8500	520	1690	470	130	50	125	253	YRTC850-XL
1030	0/-0,063	1300	0/-0,08	145	1000	10300	577	2050	540	149	40	100	375	YRTC1030-XL

medias ► <https://www.schaeffler.de/std/1F24>

① Two retaining screws

- 1) Including retaining screws or threaded extraction holes.
- 2) Short operating duration.
- 3) Diameter of inner ring for design of adjacent construction.
- 4) Attention!
For fixing holes in the adjacent construction. Observe the pitch of the bearing holes.
- 5) Tightening torque for screws to DIN EN ISO 4762, grade 10.9.
- 6) Rigidity values taking account of the rolling element set, the deformation of the bearing rings and the screw connections.
For explanations ► \square TPI 120.

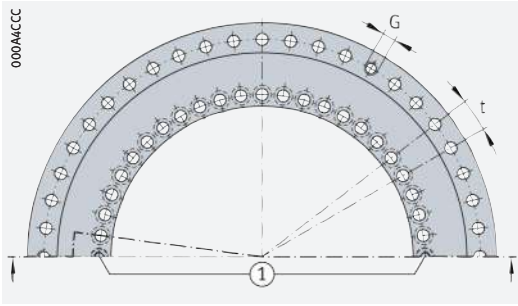

Hole pattern

Dimensions							Fixing holes						Pitch ¹⁾		Threaded extraction hole		Screw tightening torque
							Inner ring				Outer ring						
d	H ₁	H ₂	C	D ₁ ³⁾ max.	J	J ₁	d ₁	d ₂	a	Quantity ⁴⁾	d ₃	Quantity ⁴⁾	n	t	G	Quantity	M _A ⁵⁾ Nm
200	30	15	15	274,4	215	285	7	11	6,2	46	7	45	48	7,5	M8	3	14
260	36,5	18,5	18	347	280	365	9,3	15	8,2	34	9,3	33	36	10	M12	3	34
325	40	20	20	415,1	342	430	9,3	15	8,2	34	9,3	33	36	10	M12	3	34
395	42,5	22,5	20	487,7	415	505	9,3	15	8,2	46	9,3	45	48	7,5	M12	3	34
460	46	24	22	560,9	482	580	9,3	15	8,2	46	9,3	45	48	7,5	M12	3	34
580	60	30	30	700	610	720	11,4	18	11	46	11,4	42	48	7,5	M12	6	68
650	78	44	34	800	680	830	14	20	13	46	14	42	48	7,5	M12	6	116
850	80,5	43,5	37	1 018	890	1 055	18	26	17	58	18	54	60	6	M12	6	284
1 030	92,5	52,5	40	1 215	1 075	1 255	18	26	17	70	18	66	72	5	M16	6	284



d	Designation	Rigidity					
		Bearing position ⁶⁾			Rolling element set		
		axial c _{aL} kN/μm	radial c _{rL} kN/μm	Tilting rigidity c _{kL} kNm/mrad	axial c _{aL} kN/μm	radial c _{rL} kN/μm	Tilting rigidity c _{kL} kNm/mrad
200	YRTC200-XL	4,9	4,1	37	15,5	6,2	128
260	YRTC260-XL	6,9	5,3	82	19	8,1	265
325	YRTC325-XL	7,1	6,3	130	33	9,9	633
395	YRTC395-XL	9,9	5,8	228	37	13	1 002
460	YRTC460-XL	12	6,5	348	43	17	1 543
580	YRTC580-XL	11,9	2,9	735	41,8	11,2	1 960
650	YRTC650-XL	20,6	7,3	1 193	51,4	8,2	3 554
850	YRTC850-XL	26,5	11,9	2 351	61,9	12	6 772
1 030	YRTC1030-XL	36,4	11,2	5 400	74,9	14,2	11 165



Axial/radial bearings

Double direction

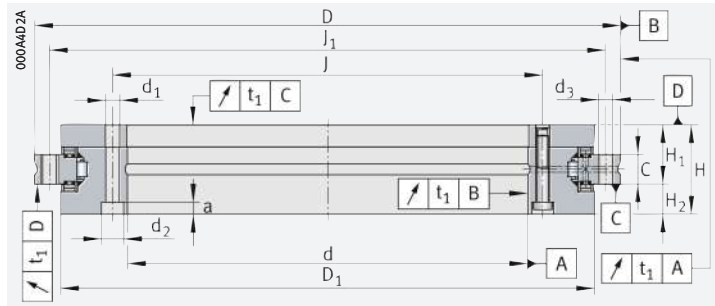

YRTS

d = 200 – 460 mm

Main dimensions			Basic load ratings				Fatigue limit load		Limiting speed n_G min^{-1}	Mass m $\approx \text{kg}$	Designation		
			axial		radial		axial	radial					
d	D	H	dyn. C_a kN	stat. C_{0a} kN	dyn. C_r kN	stat. C_{0r} kN	C_{ua} kN	C_{ur} kN					
200	0/-0,015	300	0/-0,018	45	155	840	94	226	91	31,5	1160	9,7	YRTS200
260	0/-0,018	385	0/-0,02	55	173	1050	110	305	106	39,5	910	18,3	YRTS260
325	0/-0,023	450	0/-0,023	60	191	1260	109	320	120	42	760	25	YRTS325
395	0/-0,023	525	0/-0,028	65	214	1540	121	390	139	48,5	650	33	YRTS395
460	0/-0,023	600	0/-0,028	70	221	1690	168	570	145	64	560	45	YRTS460

medias ► <https://www.schaeffler.de/std/1F25>

① Two retaining screws; ② Screw counterbores open (in the L-section ring to the bearing bore), bearing inside diameter is unsupported in this area

- 1) Including retaining screws or threaded extraction holes.
- 2) Diameter of inner ring for design of adjacent construction.
- 3) Attention!
For fixing holes in the adjacent construction. Observe the pitch of the bearing holes.
- 4) Tightening torque for screws to DIN EN ISO 4762, grade 10.9.
- 5) Rigidity values taking account of the rolling element set, the deformation of the bearing rings and the screw connections.
For explanations ► \square TPI 120.

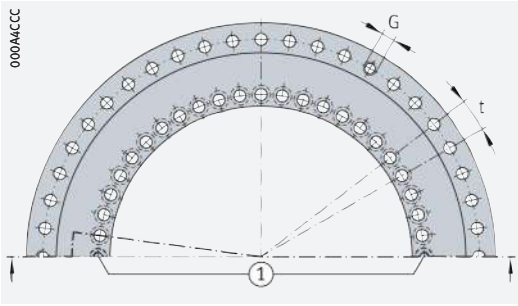

Hole pattern

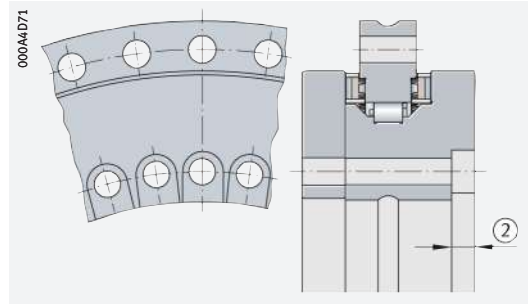

For YRTS325

Dimensions							Fixing holes						Pitch ¹⁾		Threaded extraction hole		Screw tightening torque M _A ⁴⁾ Nm
d	H ₁	H ₂	C	D ₁ ²⁾ max.	J	J ₁	Inner ring				Outer ring		n	t	G	Quantity	
							d ₁	d ₂	a	Quantity ³⁾	d ₃	Quantity ³⁾					
200	30	15	15	274,4	215	285	7	11	6,2	46	7	45	48	7,5	M8	3	14
260	36,5	18,5	18	347	280	365	9,3	15	8,2	34	9,3	33	36	10	M12	3	34
325	40	20	20	415,1	342	430	9,3	15	8,2	34	9,3	33	36	10	M12	3	34
395	42,5	22,5	20	487,7	415	505	9,3	15	8,2	46	9,3	45	48	7,5	M12	3	34
460	46	24	22	560,9	482	580	9,3	15	8,2	46	9,3	45	48	7,5	M12	3	34



d	Designation	Rigidity					
		Bearing position ⁵⁾			Rolling element set		
		axial c _{aL} kN/μm	radial c _{rL} kN/μm	Tilting rigidity c _{kL} kNm/mrad	axial c _{aL} kN/μm	radial c _{rL} kN/μm	Tilting rigidity c _{kL} kNm/mrad
200	YRTS200	4	1,2	29	13,6	3,9	101
260	YRTS260	5,4	1,6	67	16,8	5,8	201
325	YRTS325	6,6	1,8	115	19,9	7,1	350
395	YRTS395	7,8	2	195	23,4	8,7	582
460	YRTS460	8,9	1,8	280	25,4	9,5	843



Axial angular contact ball bearings

Double direction

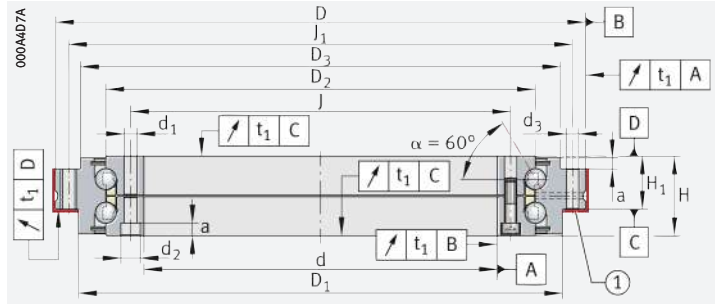

ZKLDF

d = 100 – 460 mm

Main dimensions ¹⁾			Basic load ratings		Fatigue limit load	Limiting speed ²⁾	Mass	Designation
d	D	H	dyn. C _a kN	stat. C _{0a} kN	C _{ua} kN	n _G min ⁻¹	m ≈ kg	
100	185	38	71	265	10,1	5 000	3,8	ZKLDF100
120	210	40	76	315	11,1	4 300	4,8	ZKLDF120
150	240	40	81	380	12,2	3 600	5,6	ZKLDF150
180	280	43	85	440	13,1	3 500	7,7	ZKLDF180
200	300	45	121	610	17,4	3 200	10	ZKLDF200
260	385	55	162	920	23,1	2 400	19	ZKLDF260
325	450	60	172	1 110	25	2 000	25	ZKLDF325
395	525	65	241	1 580	33	1 600	33	ZKLDF395
460	600	70	255	1 860	36	1 400	47	ZKLDF460

medias ► <https://www.schaeffler.de/std/1F26>

① Contact surface/centring diameter; ② Two retaining screws; ③ Screw counterbores open (in the L-section ring to the bearing bore), bearing inside diameter is unsupported in this area

- 1) Sizes d > 460 mm available by agreement.
- 2) The limiting speeds increased by a factor of two are valid for bearings of the current generation with the internal suffix -B.
- 3) Including retaining screws or threaded extraction holes.
- 4) Attention!
For fixing holes in the adjacent construction. Observe the pitch of the bearing holes.
- 5) Tightening torque for screws to DIN EN ISO 4762, grade 10.9.
- 6) Rigidity values taking account of the rolling element set, the deformation of the bearing rings and the screw connections.
For explanations ► □ TPI 120.

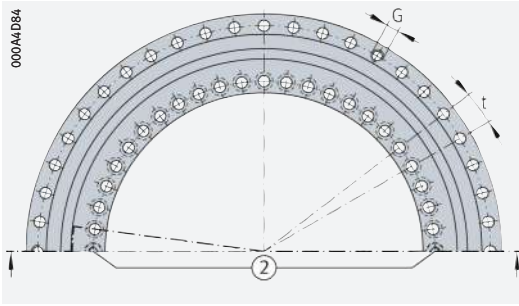

Hole pattern

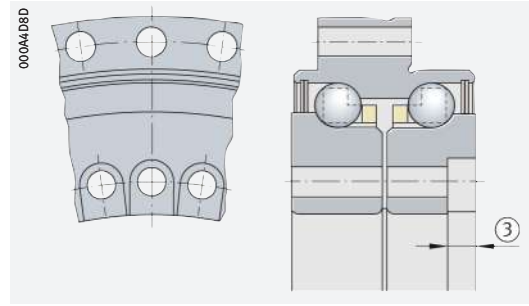

For ZKLDF100, ZKLDF325

Dimensions ¹⁾							Fixing holes						Pitch ³⁾		Threaded extraction hole		Screw tightening torque
d	H ₁	D ₁	D ₂	D ₃	J	J ₁	Inner ring				Outer ring		n	t	G	Quantity	M _A ⁵⁾ Nm
							d ₁	d ₂	a	Quantity ⁴⁾	d ₃	Quantity ⁴⁾					
100	25	161	136	158	112	170	5,6	10	5,4	16	5,6	15	18	20	M5	3	8,5
120	26	185	159	181	135	195	7	11	6,2	22	7	21	24	15	M8	3	14
150	26	214	188	211	165	225	7	11	6,2	34	7	33	36	10	M8	3	14
180	29	244	219	246	194	260	7	11	6,2	46	7	45	48	7,5	M8	3	14
200	30	274	243	271	215	285	7	11	6,2	46	7	45	48	7,5	M8	3	14
260	36,5	345	313	348	280	365	9,3	15	8,2	34	9,3	33	36	10	M12	3	34
325	40	415	380	413	342	430	9,3	15	8,2	34	9,3	33	36	10	M12	3	34
395	42,5	486	450	488	415	505	9,3	15	8,2	46	9,3	45	48	7,5	M12	3	34
460	46	560	520	563	482	580	9,3	15	8,2	46	9,3	45	48	7,5	M12	3	34



d	Designation	Rigidity					
		Bearing position ⁶⁾			Rolling element set		
		axial c _{aL} kN/μm	radial c _{rL} kN/μm	Tilting rigidity c _{kL} kNm/mrad	axial c _{aL} kN/μm	radial c _{rL} kN/μm	Tilting rigidity c _{kL} kNm/mrad
100	ZKLDF100	1,2	0,35	3,6	2,2	0,35	5
120	ZKLDF120	1,5	0,4	5,5	2,5	0,4	8
150	ZKLDF150	1,7	0,4	7,8	2,9	0,4	12
180	ZKLDF180	1,9	0,5	10,7	2,8	0,5	16
200	ZKLDF200	2,5	0,6	17,5	3,7	0,6	26
260	ZKLDF260	3,2	0,7	40	4,7	0,7	54
325	ZKLDF325	4	0,8	60	5,4	0,8	90
395	ZKLDF395	4,5	0,9	100	6,3	0,9	148
460	ZKLDF460	5,3	1,1	175	7,1	1,1	223



Axial/radial bearings

Double direction
With incremental angular measuring system

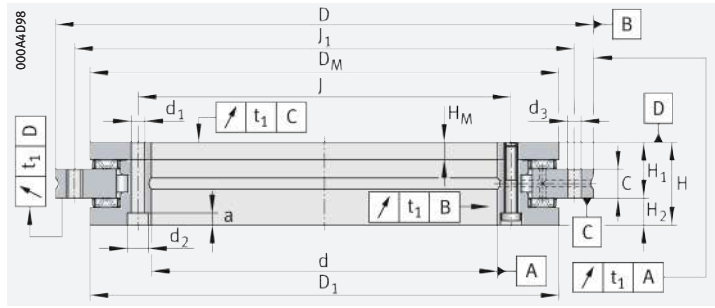

YRTM, YRTCM

d = 150 – 460 mm

Main dimensions			Basic load ratings				Fatigue limit load		Limiting speed		Mass	Designation
			axial		radial		axial	radial	Electronic evaluation system and bearing	Reference travel		
d	D	H	dyn. C _a kN	stat. C _{0a} kN	dyn. C _r kN	stat. C _{0r} kN	C _{ua} kN	C _{ur} kN			n _G min ⁻¹	n _{Ref} min ⁻¹
150	240	41 ⁶⁾	85	510	77	179	44	21,9	210	35	6,4	YRTM150 ⁷⁾
180	280	44 ⁶⁾	92	580	83	209	48,5	24,4	190	30	7,7	YRTM180 ⁷⁾
200	300	45	147	850	123	275	62	31,5	450	–	9,7	YRTCM200-XL ⁷⁾
260	385	55	168	1090	140	355	74	37,5	300	–	18,3	YRTCM260-XL
325	450	60	248	1900	183	530	130	49	200	–	25	YRTCM325-XL
395	525	65	265	2190	200	640	143	56	150	–	33	YRTCM395-XL
460	600	70	288	2550	267	880	160	77	150	–	45	YRTCM460-XL

medias ► <https://www.schaeffler.de/std/1F27>

① Two retaining screws; ② Screw counterbores open (in the L-section ring to the bearing bore), bearing inside diameter is unsupported in this area

- 1) Including retaining screws or threaded extraction holes.
- 2) Diameter of inner ring for design of adjacent construction.
- 3) Diameter of dimensional scale on shaft locating washer.
- 4) Attention!
For fixing holes in the adjacent construction. Observe the pitch of the bearing holes.
- 5) Tightening torque for screws to DIN EN ISO 4762, grade 10.9.
- 6) Attention!
H and H1 are 1 mm higher than standard bearing YRT.
- 7) The measuring head cannot be mounted between the fixing holes or the heads of the fixing screws. Two holes for fixing screws therefore remain unused in the bearing outer ring.
- 8) Rigidity values taking account of the rolling element set, the deformation of the bearing rings and the screw connections.
For explanations ► □ TPI 120.

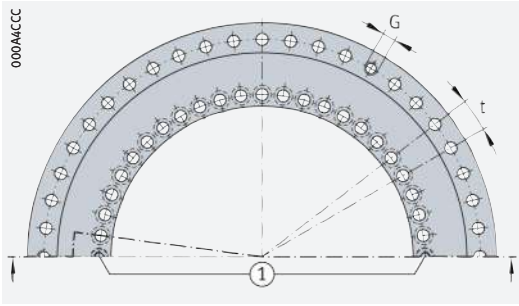

Hole pattern

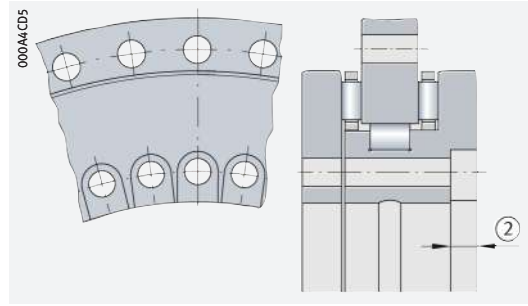

For YRTM325

Dimensions								Fixing holes					Pitch ¹⁾		Threaded extraction hole		Screw tightening torque M _A ⁵⁾ Nm	
d	H ₁	H _M	C	D ₁ ²⁾ max.	D _M ³⁾	J	J ₁	Inner ring				Outer ring		n	t	G		Quantity
								d ₁	d ₂	a	Quantity ⁴⁾	d ₃	Quantity ⁴⁾	°				
150	27 ⁶⁾	10	12	214,5	213,82	165	225	7	11	6,2	34	7	33	36	10	M8	3	14
180	30 ⁶⁾	10	15	245,1	244,38	194	260	7	11	6,2	46	7	45	48	7,5	M8	3	14
200	30	10	15	274,4	271,12	215	285	7	11	6,2	46	7	45	48	7,5	M8	3	14
260	36,5	13,5	18	347	343,69	280	365	9,3	15	8,2	34	9,3	33	36	10	M12	3	34
325	40	15	20	415,1	412,45	342	430	9,3	15	8,2	34	9,3	33	36	10	M12	3	34
395	42,5	17,5	20	487,7	485,02	415	505	9,3	15	8,2	46	9,3	45	48	7,5	M12	3	34
460	46	19	22	560,9	557,6	482	580	9,3	15	8,2	46	9,3	45	48	7,5	M12	3	34



d	Designation	Rigidity					
		Bearing position ⁸⁾			Rolling element set		
		axial c _{aL} kN/μm	radial c _{rL} kN/μm	Tilting rigidity c _{kL} kNm/mrad	axial c _{aL} kN/μm	radial c _{rL} kN/μm	Tilting rigidity c _{kL} kNm/mrad
150	YRTM150 ⁷⁾	2,3	2,6	11	8,7	4,6	38
180	YRTM180 ⁷⁾	2,6	3	17	9,9	5,3	57
200	YRTCM200-XL ⁷⁾	4,9	4,1	37	15,5	6,2	128
260	YRTCM260-XL	6,9	5,3	82	19	8,1	265
325	YRTCM325-XL	7,1	6,3	130	33	9,9	633
395	YRTCM395-XL	9,9	5,8	228	37	13	1 002
460	YRTCM460-XL	12	6,5	348	43	17	1 543



Axial/radial bearings

Double direction
With incremental angular measuring system

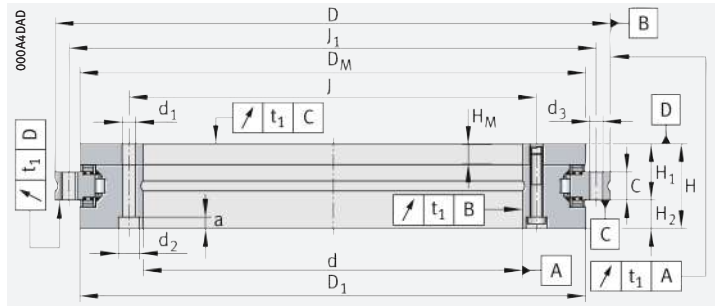

YRTSM

d = 200 – 460 mm

Main dimensions			Basic load ratings				Fatigue limit load		Limiting speed		Mass	Designation		
			axial		radial		axial	radial	Electronic evaluation system and bearing	Reference travel				
d	D	H	dyn. C _a kN	stat. C _{0a} kN	dyn. C _r kN	stat. C _{0r} kN	C _{ua} kN	C _{ur} kN			n _G min ⁻¹	n _{Ref} min ⁻¹	m ≈ kg	
200	0/-0,015	300	0/-0,018	45	155	840	226	91	31,5	1 160	30	9,7	YRTSM200 ⁶⁾	
260	0/-0,018	385	0/-0,02	55	173	1 050	110	305	106	910	25	18,3	YRTSM260	
325	0/-0,023	450	0/-0,023	60	191	1 260	109	320	120	42	760	25	25	YRTSM325
395	0/-0,023	525	0/-0,028	65	214	1 540	121	390	139	48,5	650	15	33	YRTSM395
460	0/-0,023	600	0/-0,028	70	221	1 690	168	570	145	64	560	15	45	YRTSM460

medias ► <https://www.schaeffler.de/std/1F28>

① Two retaining screws; ② Screw counterbores open (in the L-section ring to the bearing bore), bearing inside diameter is unsupported in this area

- 1) Including retaining screws or threaded extraction holes.
- 2) Diameter of inner ring for design of adjacent construction.
- 3) Diameter of dimensional scale on shaft locating washer.
- 4) Attention!
For fixing holes in the adjacent construction. Observe the pitch of the bearing holes.
- 5) Tightening torque for screws to DIN EN ISO 4762, grade 10.9.
- 6) The measuring head cannot be mounted between the fixing holes or the heads of the fixing screws.
Two holes for fixing screws therefore remain unused in the bearing outer ring.
- 7) Rigidity values taking account of the rolling element set, the deformation of the bearing rings and the screw connections.
For explanations ► [TPI 120](#).

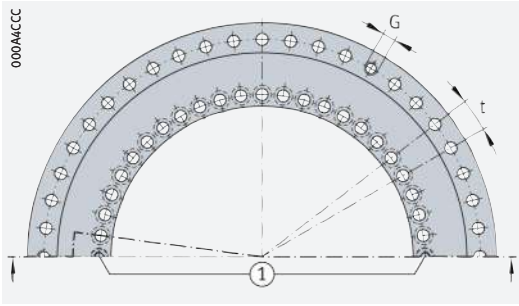

Hole pattern

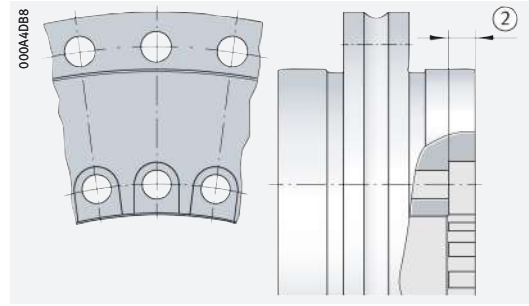

For YRTSM325

Dimensions								Fixing holes						Pitch ¹⁾		Threaded extraction hole		Screw tightening torque M _A ⁵⁾ Nm
d	H ₁	H _M	C	D ₁ ²⁾ max.	D _M ³⁾	J	J ₁	Inner ring				Outer ring		n	t °	G	Quantity	
								d ₁	d ₂	a	Quantity ⁴⁾	d ₃	Quantity ⁴⁾					
200	30	10	15	274,4	271,12	215	285	7	11	6,2	46	7	45	48	7,5	M8	3	14
260	36,5	13,5	18	347	343,69	280	365	9,3	15	8,2	34	9,3	33	36	10	M12	3	34
325	40	15	20	415,1	412,45	342	430	9,3	15	8,2	34	9,3	33	36	10	M12	3	34
395	42,5	17,5	20	487,7	485,02	415	505	9,3	15	8,2	46	9,3	45	48	7,5	M12	3	34
460	46	19	22	560,9	557,6	482	580	9,3	15	8,2	46	9,3	45	48	7,5	M12	3	34



d	Designation	Rigidity					
		Bearing position ⁷⁾			Rolling element set		
		axial c _{aL} kN/μm	radial c _{rL} kN/μm	Tilting rigidity c _{kL} kNm/mrad	axial c _{aL} kN/μm	radial c _{rL} kN/μm	Tilting rigidity c _{kL} kNm/mrad
200	YRTSM200 ⁶⁾	4	1,2	29	13,6	3,9	101
260	YRTSM260	5,4	1,6	67	16,8	5,8	201
325	YRTSM325	6,6	1,8	115	19,9	7,1	350
395	YRTSM395	7,8	2	195	23,4	8,7	582
460	YRTSM460	8,9	1,8	280	25,4	9,5	843

Axial/radial bearings

Double direction
With absolute value angular measuring system

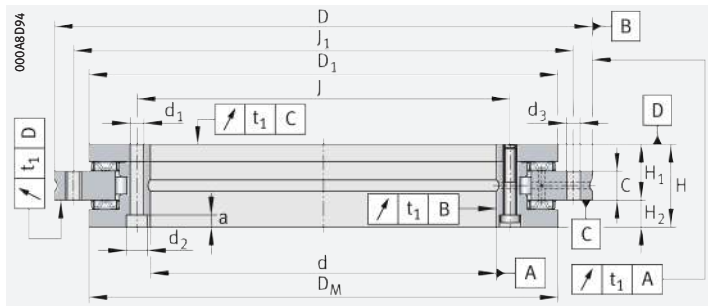

YRTCMA

d = 200 – 460 mm

Main dimensions				Basic load ratings				Fatigue limit load		Limiting speed ¹⁾	Mass	Designation	
d	D	H	axial		radial		axial	radial					
			dyn. C _a	stat. C _{0a}	dyn. C _r	stat. C _{0r}	C _{ua}	C _{ur}	n _G	m			
200	0/-0,015	300	0/-0,018	51 ⁷⁾	147	850	123	275	62	31,5	450	10,7	YRTCMA200-XL
260	0/-0,018	385	0/-0,02	57,5 ⁷⁾	168	1090	140	355	74	37,5	300	18,7	YRTCMA260-XL
325	0/-0,023	450	0/-0,023	61	248	1900	183	530	130	49	200	25	YRTCMA325-XL
395	0/-0,023	525	0/-0,028	65	265	2190	200	640	143	56	150	33	YRTCMA395-XL
460	0/-0,023	600	0/-0,028	70	288	2550	267	880	160	77	150	45	YRTCMA460-XL

medias ► <https://www.schaeffler.de/std/1F29>

① Two retaining screws; ② Screw counterbores open (in the L-section ring to the bearing bore), bearing inside diameter is unsupported in this area; ③ Shaft locating washer; ④ Inner ring

- For high operating durations or continuous operation, please contact us.
- Including retaining screws or threaded extraction holes.
- Diameter of shaft locating washer for design of adjacent construction.
- Diameter of dimensional scale on inner ring.
- Attention!
For fixing holes in the adjacent construction. Observe the pitch of the bearing holes.
- Tightening torque for screws to DIN EN ISO 4762, grade 10.9.
- Dimension differs from the axial/radial bearing YRT.
- Rigidity values taking account of the rolling element set, the deformation of the bearing rings and the screw connections.
For explanations ► □ TPI 120.

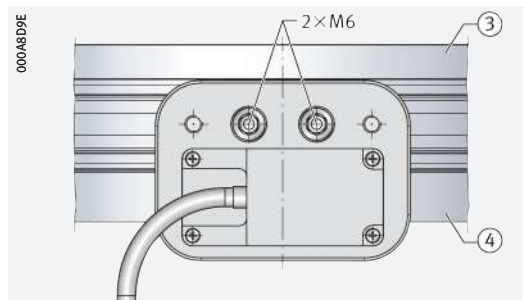

Measuring head suitable for radial screw mounting

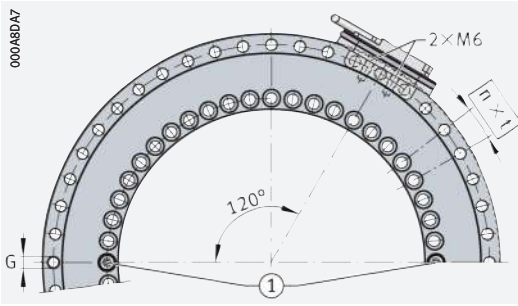

Hole pattern, measuring head suitable for radial screw mounting

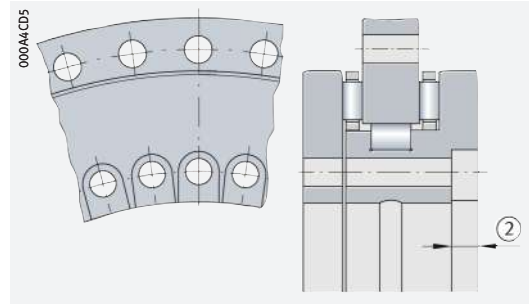

For YRTCMA325

Dimensions							Fixing holes						Pitch ²⁾		Threaded extraction hole		Screw tightening torque M _A ⁶⁾ Nm
d	H ₁	C	D ₁ ³⁾	D _M ⁴⁾ max.	J	J ₁	Inner ring				Outer ring		n	t	G	Quantity	
							d ₁	d ₂	a	Quantity ⁵⁾	d ₃	Quantity ⁵⁾					
200	30	15	274	274,4	215	285	7	11	6,2	46	7	45	48	7,5	M8	3	14
260	36,5	18	345	347	280	365	9,3	15	8,2	34	9,3	33	36	10	M12	3	34
325	40	20	415	415,1	342	430	9,3	15	8,2	34	9,3	33	36	10	M12	3	34
395	42,5	20	486	487,7	415	505	9,3	15	8,2	46	9,3	45	48	7,5	M12	3	34
460	46	22	560	560,9	482	580	9,3	15	8,2	46	9,3	45	48	7,5	M12	3	34



d	Designation	Rigidity					
		Bearing position ⁸⁾			Rolling element set		
		axial c _{aL} kN/μm	radial c _{rL} kN/μm	Tilting rigidity c _{kL} kNm/mrad	axial c _{aL} kN/μm	radial c _{rL} kN/μm	Tilting rigidity c _{kL} kNm/mrad
200	YRTCMA200-XL	4,9	4,1	37	15,5	6,2	128
260	YRTCMA260-XL	7,1	6,3	130	33	9,9	633
325	YRTCMA325-XL	9,9	5,8	228	37	13	1002
395	YRTCMA395-XL	12	6,5	348	43	17	1543
460	YRTCMA460-XL	6,9	5,3	82	19	8,1	265



Axial/radial bearings

Double direction
With absolute value angular measuring system

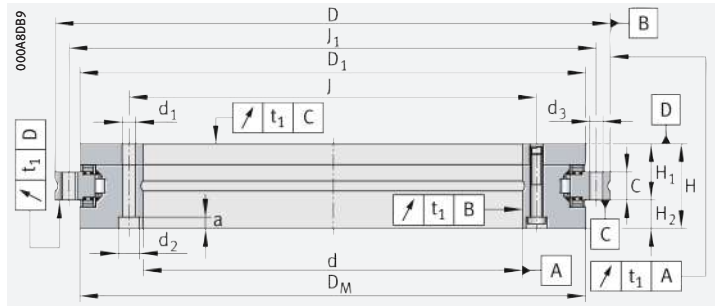

YRTSMA

d = 200 – 460 mm

Main dimensions				Basic load ratings				Fatigue limit load		Limiting speed ¹⁾	Mass	Designation	
d	D	H	axial		radial		axial	radial					
			dyn. C _a kN	stat. C _{0a} kN	dyn. C _r kN	stat. C _{0r} kN	C _{ua} kN	C _{ur} kN	n _G min ⁻¹	m ≈ kg			
200	0/-0,015	300	0/-0,018	51 ⁷⁾	155	840	94	226	91	31,5	1160	10,7	YRTSMA200
260	0/-0,018	385	0/-0,02	57,5 ⁷⁾	173	1050	110	305	106	39,5	910	18,7	YRTSMA260
325	0/-0,023	450	0/-0,023	61 ⁷⁾	191	1260	109	320	120	42	760	25	YRTSMA325
395	0/-0,023	525	0/-0,028	65	214	1540	121	390	139	48,5	650	33	YRTSMA395
460	0/-0,023	600	0/-0,028	70	221	1690	168	570	145	64	560	45	YRTSMA460

medias ► <https://www.schaeffler.de/std/1F2A>

① Two retaining screws; ② Screw counterbores open (in the L-section ring to the bearing bore), bearing inside diameter is unsupported in this area; ③ Shaft locating washer; ④ Inner ring

- 1) For high operating durations or continuous operation, please contact us.
- 2) Including retaining screws or threaded extraction holes.
- 3) Diameter of shaft locating washer for design of adjacent construction.
- 4) Diameter of dimensional scale on inner ring.
- 5) Attention!
For fixing holes in the adjacent construction. Observe the pitch of the bearing holes.
- 6) Tightening torque for screws to DIN EN ISO 4762, grade 10.9.
- 7) Dimension differs from the axial/radial bearing YRTS.
- 8) Rigidity values taking account of the rolling element set, the deformation of the bearing rings and the screw connections.
For explanations ► □ TPI 120.

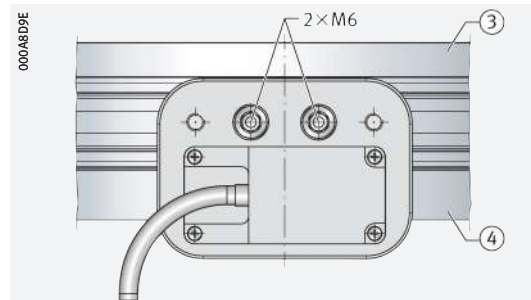

Measuring head suitable for radial screw mounting

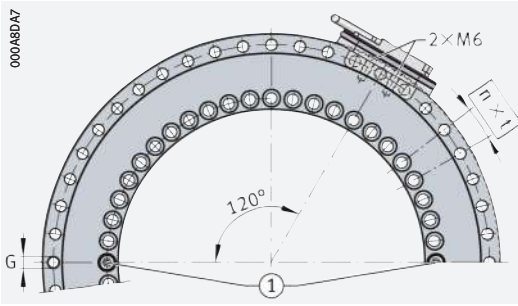

Hole pattern, measuring head suitable for radial screw mounting

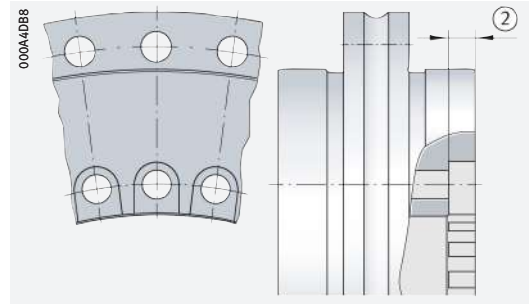

For YRTSMA325

Dimensions							Fixing holes						Pitch ²⁾		Threaded extraction hole		Screw tightening torque M _A ⁶⁾ Nm
d	H ₁	C	D ₁ ³⁾	D _M ⁴⁾ max.	J	J ₁	Inner ring				Outer ring		n	t	G	Quantity	
							d ₁	d ₂	a	Quantity ⁵⁾	d ₃	Quantity ⁵⁾					
200	30	15	274	274,4	215	285	7	11	6,2	46	7	45	48	7,5	M8	3	14
260	36,5	18	345	347	280	365	9,3	15	8,2	34	9,3	33	36	10	M12	3	34
325	40	20	415	415,1	342	430	9,3	15	8,2	34	9,3	33	36	10	M12	3	34
395	42,5	20	486	487,7	415	505	9,3	15	8,2	46	9,3	45	48	7,5	M12	3	34
460	46	22	560	560,9	482	580	9,3	15	8,2	46	9,3	45	48	7,5	M12	3	34





d	Designation	Rigidity					
		Bearing position ⁸⁾			Rolling element set		
		axial c _{aL} kN/μm	radial c _{rL} kN/μm	Tilting rigidity c _{kL} kNm/mrad	axial c _{aL} kN/μm	radial c _{rL} kN/μm	Tilting rigidity c _{kL} kNm/mrad
200	YRTSMA200	4	1,2	29	13,6	3,9	101
260	YRTSMA260	5,4	1,6	67	16,8	5,8	201
325	YRTSMA325	6,6	1,8	115	19,9	7,1	350
395	YRTSMA395	7,8	2	195	23,4	8,7	582
460	YRTSMA460	8,9	1,8	280	25,4	9,5	843

4 App for super precision bearings

4.1 PrecisionDesk

PrecisionDesk simplifies bearing selection and assists in the mounting of bearing arrangement components

The free-of-charge Schaeffler app PrecisionDesk for super precision bearings includes services for rotary and linear bearings of a high precision design ► 1374 |  1. It assists fitters and engineers in the selection and mounting of bearing arrangement components.

 1
PrecisionDesk
for super precision bearings

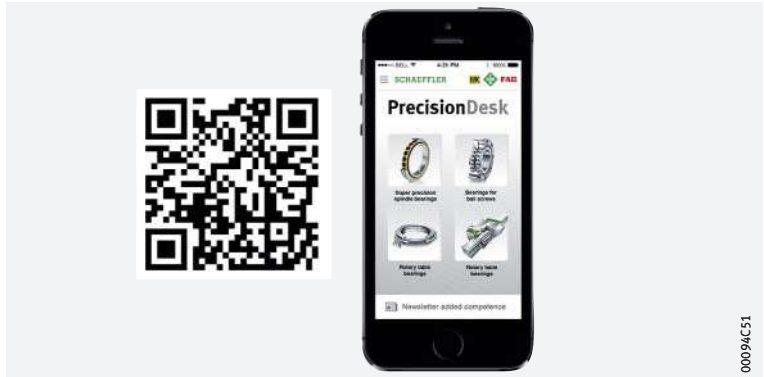

Advantages

The advantage for the user is that the data can be accessed from any smartphone. For example, the app can be used to call off bearing-specific measurement records for spindle and rotary table bearings directly and store or send these for the purposes of documentation. For spindle bearings, it is possible to create electronic, bearing-specific data sets in the .csv format and use these, for example, for a logistics system. The app offers Schaeffler customers the possibility of monitoring their own inventory and improving quality in mounting. With such a service tool, Schaeffler is a pioneer in the market.

Access via DMC

Scanning the data matrix code (DMC) on the bearing or the bearing packaging gives access to the scope of performance of the program ► 1374 |  2.

 2
Data matrix code
on rolling bearing



- ☞ *Scope of performance* The scope of performance of the app comprises ► 1375 | 3:
- checking of data matrix codes (anti-piracy protection)
 - measurement records for spindle and rotary table bearings
 - recommendations for mounting
 - performance data.

3
Scope of performance
of PrecisionDesk

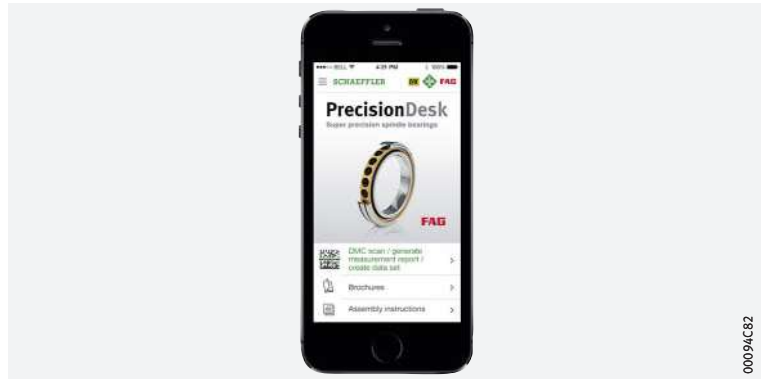

- ☞ *Measurement records for spindle bearings* The measurement records which can be generated contain the following ► 1375 | 4:
- bearing ID
 - designation
 - date of manufacture
 - actual value codes (bore diameter, outside diameter)
 - width deviation
 - contact angle
 - overhang.

4
Measurement record
for spindle bearings

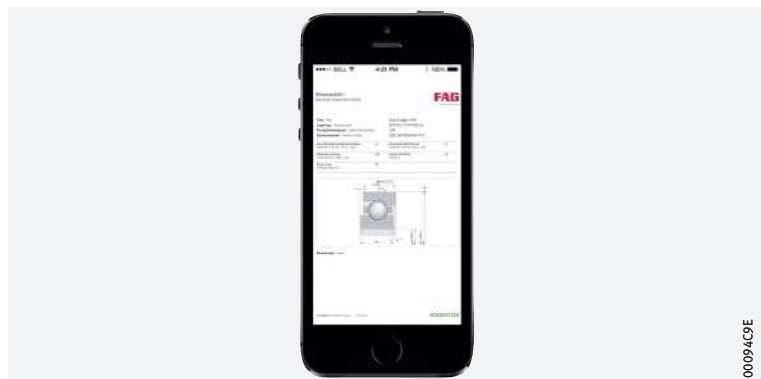

- ☞ *Recommendations for mounting*
- Correct grease quantity
 - Grease distribution cycle
 - Universal bearing sets
 - Permissible heating temperatures
 - Designation and marking.

- ☞ *Performance data*
- Catalogue information
 - Additional product information
 - Direct access to Schaeffler Library.



The PrecisionDesk app can be used on Android, IOS and Windows-based operating systems and can be downloaded from the corresponding app stores ► <https://www.schaeffler.de/std/1D59>.



Track rollers

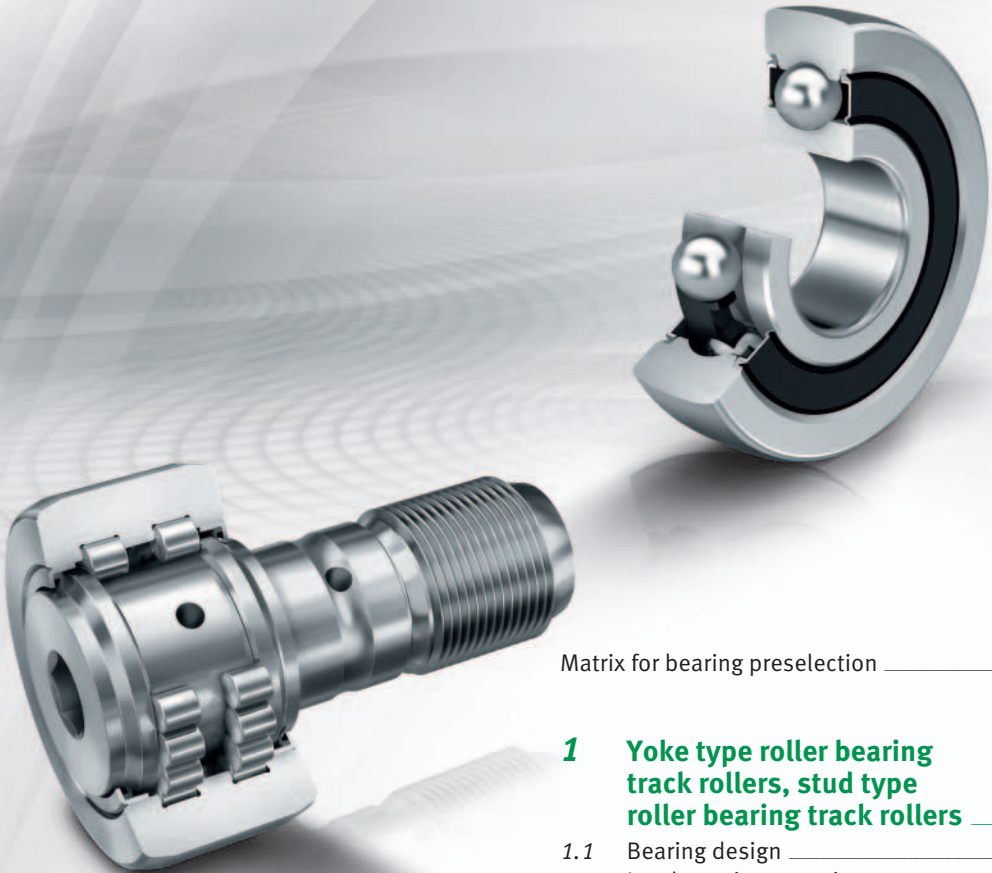



Matrix for bearing preselection 1378

1 Yoke type roller bearing track rollers, stud type roller bearing track rollers **1380**

1.1	Bearing design	1380
1.2	Load carrying capacity	1390
1.3	Angular misalignment	1391
1.4	Lubrication	1392
1.5	Sealing	1395
1.6	Speeds	1396
1.7	Noise	1396
1.8	Temperature range	1397
1.9	Cages	1397
1.10	Internal clearance	1398
1.11	Dimensions, tolerances	1398
1.12	Suffixes	1398
1.13	Structure of bearing designation	1399
1.14	Dimensioning	1400
1.15	Minimum load	1402
1.16	Design of bearing arrangements	1402



1.17	Mounting and dismantling	1411	2.5	Sealing	1432
1.18	Legal notice regarding data freshness	1414	2.6	Speeds	1433
1.19	Further information	1415	2.7	Noise	1433
	Product tables	1416	2.8	Temperature range	1434
	Yoke type roller bearing track rollers without axial guidance, open	1416	2.9	Cages	1434
	Yoke type roller bearing track rollers without axial guidance, sealed	1417	2.10	Internal clearance	1434
	Yoke type roller bearing track rollers with axial guidance	1418	2.11	Dimensions, tolerances	1435
	Yoke type roller bearing track rollers with axial guidance, sealed	1419	2.12	Suffixes	1435
	Yoke type roller bearing track rollers with optimised INA profile	1420	2.13	Structure of bearing designation	1435
	Stud type needle roller bearing track rollers with axial guidance	1422	2.14	Dimensioning	1436
	Stud type cylindrical roller bearing track rollers with axial guidance	1426	2.15	Minimum load	1436
			2.16	Design of bearing arrangements	1437
			2.17	Mounting and dismantling	1437
			2.18	Legal notice regarding data freshness	1439
			2.19	Further information	1439
				Product tables	1440
				Yoke type ball bearing track rollers, single row, sealed	1440
				Yoke type ball bearing track rollers, double row, sealed	1441
				Stud type ball bearing track rollers, sealed	1444
				Stud type ball bearing track rollers with eccentric collar, sealed	1446
				Track rollers with plastic outer tyre, sealed	1447
2	Yoke type ball bearing track rollers, stud type ball bearing track rollers	1428			
2.1	Bearing design	1428			
2.2	Load carrying capacity	1431			
2.3	Compensation of angular misalignments	1432			
2.4	Lubrication	1432			





Matrix for bearing preselection

The matrix gives an overview of the types and design features of yoke type track rollers, stud type track rollers and ball bearing track rollers.

It can be used to make a preliminary assessment of whether a bearing is fundamentally suitable for the envisaged application.

The additional information provided in the product chapter (see column "detailed information") and in the Technical principles must, however, be observed in addition to this overview in selection of the bearing.

Design features and suitability			Yoke type roller bearing track rollers			
+++ extremely suitable ++ highly suitable + suitable (+) suitable with restrictions - not suitable/not applicable ✓ available			without axial guidance	with axial guidance	with axial guidance, INA profile, sealed	detailed information
						1380
Load carrying capacity	radial		+++	+++	+++	➤ 1390 1.2
	axial, one direction ¹⁾		(+)	(+)	(+)	➤ 1390 1.2
	axial, both directions ¹⁾		(+)	(+)	(+)	➤ 1390 1.2
	moments		-	-	-	
Compensation of angular misalignments	static		++	++	++	➤ 1391 1.3
	dynamic		+	+	+	➤ 1391 1.3
Bearing design	cylindrical bore		✓	✓	✓	➤ 1380 1.1
	tapered bore		-	-	-	
	separable		✓	✓ ²⁾	-	➤ 1380 1.1
Lubrication	greased		✓	✓	✓	➤ 1392 1.4
Sealing	open		✓	-	-	➤ 1395 1.5
	non-contact		-	✓	✓	➤ 1395 1.5
	contact		✓	✓	✓	➤ 1395 1.5
Operating temperature in °C	from to		-30 +140 ³⁾	-30 +140 ³⁾	-30 +140 ³⁾	➤ 1397 1.8
Suitability for	high speeds		++	++	++	➤ 1396 1.6
	high running accuracy		++	++	++	➤ 1398 1.11
	low-noise running		+	+	+	➤ 1396 1.7 ➤ 27
	high rigidity		+++	+++	+++	➤ 54
	reduced friction		++	++	++	➤ 56
	length compensation within bearing		-	-	-	➤ 25
	non-locating bearing arrangement		-	-	-	➤ 139
	locating bearing arrangement		-	-	-	➤ 139
X-life bearings			-	-	✓	➤ 1381
Outside diameter D in mm	from to		16 90	5 310	35 100	➤ 1416
Product tables	from page		1416	1418	1420	

1) Support of axial forces due to tilting and skewed running
➤ 1391|1.3 and ➤ 1432|2.3

2) Inner rings or open design only

3) Valid only for yoke or stud type roller bearing track rollers with a metal cage or full complement roller designs, if unsealed or with a gap or labyrinth seal. Other values ➤ 1397|8



Stud type needle roller bearing track rollers with axial guidance		detailed information	Ball bearing track rollers						
+++	+++		single row	double row	stud type ball bearing track rollers	with plastic outer tyre	detailed information		
+++	+++	▶ 1380	▶ 1390 1.2	+++	+++	+++	+++	▶ 1431 2.2	
(+)	(+)	▶ 1390 1.2		+	+	+	+	▶ 1431 2.2	
(+)	(+)	▶ 1390 1.2		+	+	+	+	▶ 1431 2.2	
-	-			-	-	-	-		
++	++	▶ 1391 1.3		++	++	++	++	▶ 1432 2.3	
+	+	▶ 1391 1.3		++	++	++	++	▶ 1432 2.3	
✓	✓	▶ 1380 1.1		✓	✓	✓	✓	▶ 1428 2.1	
-	-			-	-	-	-		
-	-	▶ 1380 1.1		-	-	-	-	▶ 1428 2.1	
✓	✓	▶ 1392 1.4		✓	✓	✓	✓	▶ 1432 2.4	
-	-	▶ 1395 1.5		-	-	-	-	▶ 1432 2.5	
✓	✓	▶ 1395 1.5		-	✓	✓	✓	▶ 1432 2.5	
✓	✓	▶ 1395 1.5		✓	✓	✓	✓	▶ 1432 2.5	
-30 +140 ³⁾	-30 +140 ³⁾	▶ 1397 1.8		-20 +120	-20 +120	-20 +120	-20 +80	▶ 1434 2.8	
++	++	▶ 1396 1.6		+++	+++	+++	+++	▶ 1433 2.6	
++	++	▶ 1398 1.11		++	++	++	++	▶ 1435 2.11 ▶ 114	
+	+	▶ 1396 1.7 ▶ 27		+	+	+	+	▶ 1433 2.7 ▶ 27	
++	++	▶ 54		+	+	+	+	▶ 54	
++	++	▶ 56		+++	+++	+++	+++	▶ 56	
-	-	▶ 25		-	-	-	-	▶ 25	
-	-	▶ 139		-	-	-	-	▶ 139	
-	-	▶ 139		-	-	-	-	▶ 139	
-	✓	▶ 1384		-	✓	-	-	▶ 1431	
16 90	35 90	▶ 1422		13 90	17 100	35 80	27,5 46,8	▶ 1440	
1422	1426			1440	1441	1444	1447		



1 Yoke type roller bearing track rollers, stud type roller bearing track rollers



Yoke and stud type roller bearing track rollers:

- are ready-to-fit needle or cylindrical roller bearings of single or double row design > 1382|☐ 2 to > 1387|☐ 14
- are mounted on shafts or studs (yoke type track rollers) or supplied with a heavy-section roller stud with fixing thread and a mounting aid (stud type track rollers) > 1380|☐ 1
- have particularly thick-walled outer rings with a crowned outside surface > 1380|1.1
- can support high radial loads > 1390|1.2
- tolerate axial loads which are due to small misalignment defects, skewed running or temporary contact running impacts > 1391|1.3
- are available with or without an inner ring (yoke type track rollers)
- are produced with or without axial guidance of the outer ring (stud type track rollers are always produced with axial guidance)
- are open or sealed on both sides > 1395|1.5
- are not mounted in a housing bore, but are supported on a flat mating track > 1380|☐ 1
- can be adjusted to the mating track in the design with the eccentric collar, thus permitting, for example, larger manufacturing tolerances in the adjacent construction.

 1
Double row stud type track roller supported on a flat mating track

① Mating track

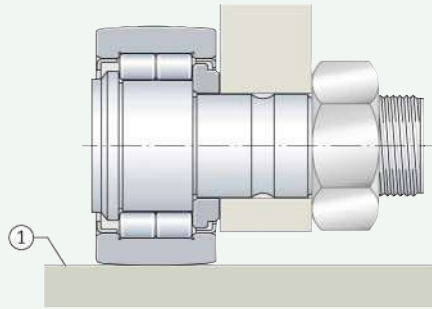

1.1 Bearing design

Design variants

This range of yoke type track rollers comprises bearings:

- with or without an inner ring (without axial guidance) > 1382|☐ 2, > 1382|☐ 3
- with an inner ring (with axial guidance)
 - with cage > 1383|☐ 4
 - full complement needle roller set > 1383|☐ 5
 - full complement cylindrical roller set > 1383|☐ 6
 - full complement cylindrical roller set, with central rib > 1384|☐ 7.

Stud type track rollers are available in the following designs:

- Without eccentric collar
 - with cage ► 1385 | 8
 - full complement needle roller set ► 1385 | 9
 - full complement cylindrical roller set ► 1386 | 10
 - full complement cylindrical roller set and with central rib ► 1386 | 11
- With eccentric collar
 - with cage ► 1387 | 12
 - full complement cylindrical roller set ► 1387 | 13
 - full complement cylindrical roller set and with central rib ► 1387 | 14.

Yoke type track rollers (general)

Yoke type track rollers are single or double row units mounted on shafts or studs ► 1382 | 2 to ► 1384 | 7. They comprise thick-walled outer rings with a profiled outside surface and needle roller and cage assemblies or full complement needle roller or cylindrical roller sets. Yoke type track rollers can support high radial loads as well as axial loads arising from slight misalignment and skewed running. The bearings are available with or without an inner ring, with or without axial guidance and in sealed or open versions.

☞ *The bearings have thick-walled outer rings and are mounted on shafts or studs*

☞ *Typical applications*

Proven areas of application of these products include cam gears, bed ways, conveying equipment and linear guidance systems.

☞ *The outside surface is predominantly crowned*

Outside surface profile of the outer ring

Bearings with a crowned outside surface are predominantly used in practice since skewing usually occurs relative to the mating track and edge stresses must be avoided.

☞ *Radius of curvature*

The radius of curvature of the outside surface is $R = 500$ mm. In the case of series NNTR..-2ZL, the radius is indicated in the product table.

☞ *Optimised INA profile*

Yoke type track rollers NATR..-PP, NATV..-PP, NUTR and PWTR..-2RS have an outside surface with the optimised INA profile ► 1387. In yoke type track rollers with this curvature profile:

- the Hertzian pressure is lower ► 1388 | 15, ► 1388 | 16
- edge loading under tilting is lower ► 1388 | 16
- wear of the mating track is reduced ► 1389 | 18, ► 1389 | 19
- the operating life of the mating track is extended ► 1388 | 17
- the rigidity in the outer ring contact is increased ► 1389 | 20.



X-life

X-life premium quality

Series PWTR is supplied as an X-life design. Due to a modified material and the optimised raceway geometry of the outer rings, the basic rating life has been increased by up to 30%. The static and dynamic load carrying capacity has also been increased. At the same time, the stress placed on the mating track has been reduced as a result of the optimised surface profile and its improved surface quality.

☞ *Lower operating costs, higher machine availability*

In conclusion, these advantages improve the overall cost-efficiency of the bearing position significantly and thus bring about a sustainable increase in the efficiency of the machine and equipment.

☞ *Suffix XL*

X-life yoke type track rollers include the suffix XL in the designation.

Yoke type track rollers without inner ring, without axial guidance

☞ *The raceway must be designed as a rolling bearing raceway*

Yoke type track rollers RSTO and RNA22..-2RSR do not have an inner ring ► 1382 | 2. Depending on the design, yoke type track rollers are also available as sealed versions ► 1395 | 1.5. They are particularly compact but require a hardened and ground raceway on the shaft or stud. Series RSTO is not self-retaining, which means that the outer ring and the needle roller and cage assembly can be fitted independently of each other. This gives simplified mounting of the bearings.



The rolling elements are guided by the cage. These designs do not have axial guidance of the outer ring. Axial guidance of the outer ring and needle roller and cage assembly (for RSTO only) must be provided in the adjacent construction.



Yoke type track rollers without inner ring, without axial guidance, open or sealed on both sides

F_r = radial load

F_a = axial load

① Open (RSTO)

② Contact seals (RNA22..-2RSR)

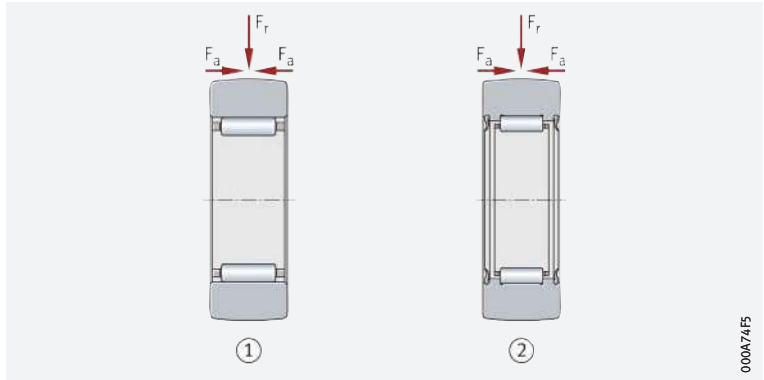

000A74F5

Yoke type track rollers with inner ring, without axial guidance

Yoke type track rollers STO and NA22..-2RSR have an inner ring ► 1382 | 3. Depending on the design, yoke type track rollers are also available as sealed versions ► 1395 | 1.5. Bearings with an inner ring are used if the shaft or stud does not have a hardened and ground raceway. Series STO is not self-retaining. This means that the outer ring, needle roller and cage assembly and the inner ring can be fitted independently of each other. This gives simplified mounting of the bearings.



The rolling elements are guided by the cage. These designs do not have axial guidance of the outer ring. Axial guidance of the outer ring and needle roller and cage assembly (for STO only) must be provided in the adjacent construction.



Yoke type track rollers with inner ring, without axial guidance, open or sealed on both sides

F_r = radial load

F_a = axial load

① Open (STO)

② Contact seals (NA22..-2RSR)

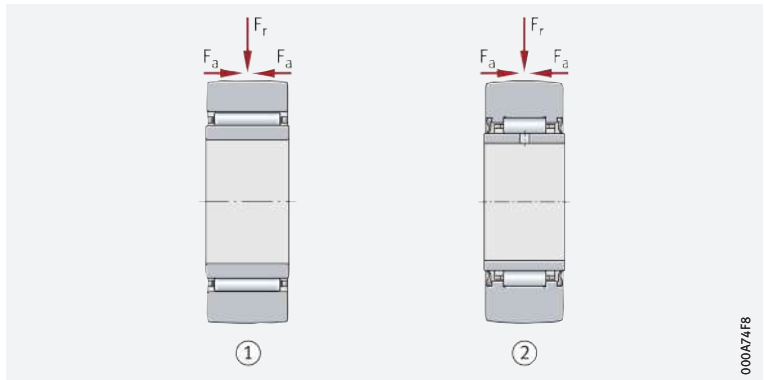

000A74F8

Yoke type track rollers with inner ring, with axial guidance

Yoke type track rollers with an inner ring are used if the shaft or stud does not have a hardened and ground raceway.



The series NATR and NATR..-PP have a cage ► 1383 | 4.

The series NATV and NATV..-PP have a full complement needle roller set, while yoke type track rollers NUTR have a full complement cylindrical roller set ► 1383 | 5 and ► 1383 | 6. Yoke type track rollers PWTR..-2RS and NNTR..-2ZL have a full complement cylindrical roller set and a central rib ► 1384 | 7. Depending on the design, yoke type track rollers are also available as sealed versions ► 1395 | 1.5.



Bearings without a cage have the largest possible number of rolling elements and therefore have particularly high load carrying capacity. Due to the kinematic conditions, however, the speeds achievable with these bearings are somewhat lower than those achievable with the cage-guided yoke type track rollers.

Axial guidance of outer ring

In NATR and NATV, axial guidance is provided directly by contact washers, while in NATR..-PP and NATV..-PP this is provided by contact washers and plastic axial plain washers. In NUTR, the outer ring is guided by the rolling elements, in PWTR..-2RS and NNTR..-2ZL it is guided by the central rib and the rolling elements.

Corrosion protection

Series PWTR..-2RS-RR is protected against corrosion by the special Cr(VI)-free coating Corrotect ► 1389. These bearings have the suffix RR.

The type of guidance is dependent on the series

Corrosion protection by Corrotect



4
Yoke type track rollers with inner ring, with cage, with axial guidance, open or sealed on both sides

F_r = radial load
 F_a = axial load

- ① Gap seals (NATR)
- ② Plastic axial plain washers (NATR..-PP)

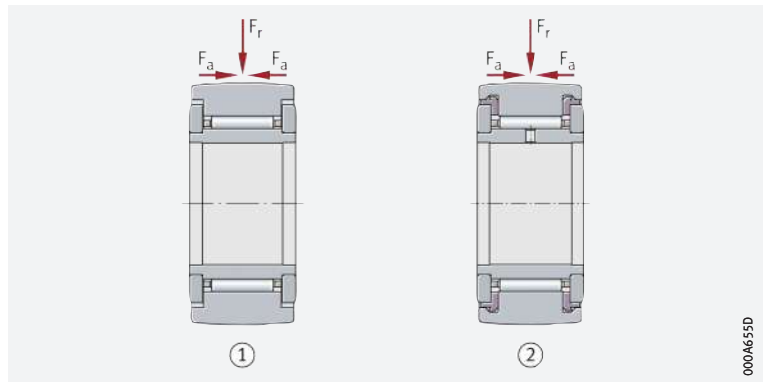

000A655D



5
Yoke type track rollers with inner ring, full complement needle roller set, with axial guidance, open or sealed on both sides

F_r = radial load
 F_a = axial load

- ① Gap seals (NATV)
- ② Plastic axial plain washers (NATV..-PP)

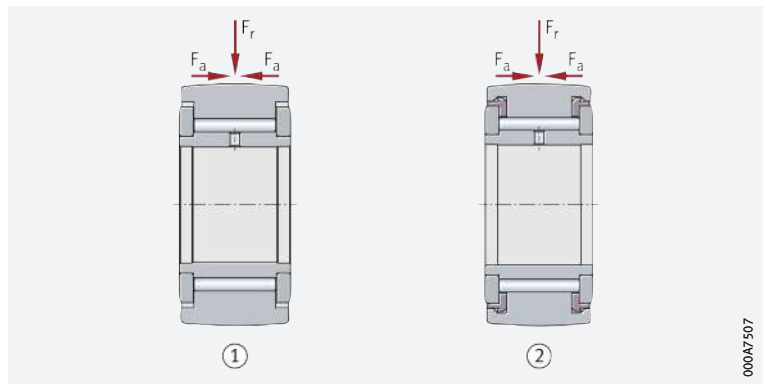

000A7507



6
Yoke type track roller with inner ring, full complement cylindrical roller set, with axial guidance, sealed on both sides

F_r = radial load
 F_a = axial load

- ① Labyrinth seals (NUTR)

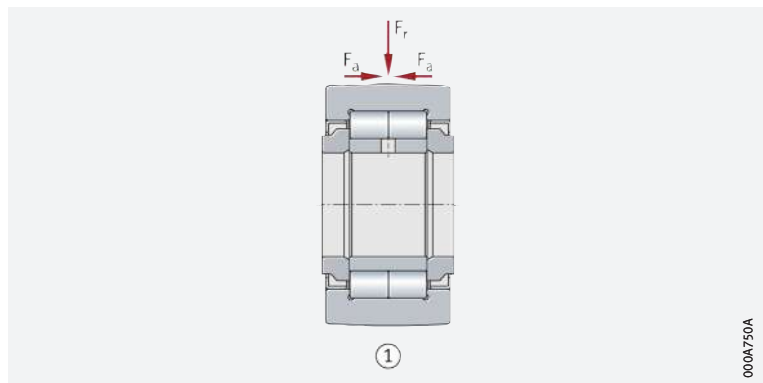

000A750A



Yoke type track rollers with inner ring, full complement cylindrical roller set, with central rib, with axial guidance, sealed on both sides

F_r = radial load

F_a = axial load

- ① Protected lip seals (PWTR...-2RS)
- ② Contact washers with lamellar ring (NNTR...-2ZL)

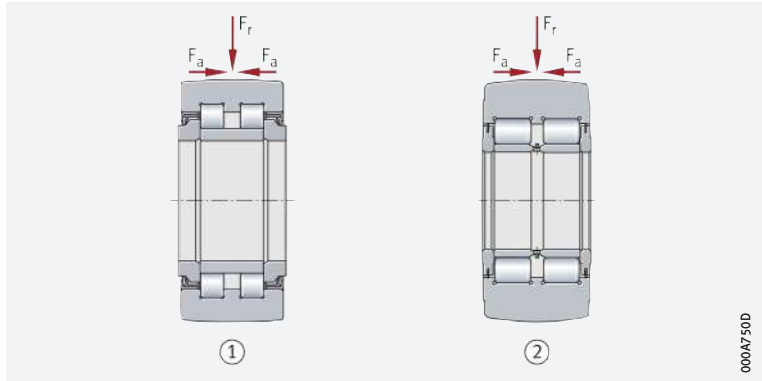

The bearings have thick-walled outer rings and a heavy-section roller stud

Typical applications

The outside surface is crowned

Radius of curvature

Optimised INA profile

Stud type track rollers (general)

Stud type track rollers are similar in their construction to single and double row yoke type track rollers with axial guidance, except that the raceway is formed by a heavy-section roller stud with a fixing thread and type-dependent mounting aid, and with a type-dependent relubrication facility. Due to the thick-walled outer ring with profiled outside surface and the rolling element set, they can support high radial loads as well as axial loads arising from slight misalignment and skewed running. The stud type track rollers are available with or without an eccentric collar ▶ 1385 | ⑧ 8 to ▶ 1387 | ⑧ 14.

Proven areas of application of these products include cam gears, bed ways, conveying equipment and linear guidance systems.

Outside surface profile of the outer ring

Stud type track rollers with a crowned outside surface are predominantly used since skewing usually occurs relative to the mating track and edge stresses must be avoided.

In series KR, the radius of curvature is $R = 500$ mm. The series KR...-PP, KRE...-PP, KRV...-PP, NUKR, NUKRE, PWKR...-2RS and PWKRE...-2RS have an outside surface with the optimised INA profile.

In stud type track rollers with the optimised INA profile:

- the Hertzian pressure is lower ▶ 1388 | ⑧ 15, ▶ 1388 | ⑧ 16
- edge loading under tilting is lower ▶ 1388 | ⑧ 16
- wear of the mating track is reduced ▶ 1389 | ⑧ 18, ▶ 1389 | ⑧ 19
- the operating life of the mating track is extended ▶ 1388 | ⑧ 17
- the rigidity in the outer ring contact is increased ▶ 1389 | ⑧ 20.

X-life premium quality

Stud type track rollers PWKR(E) are supplied in the X-life design. Due to a modified material and the optimised raceway geometry of the outer rings, the basic rating life has been increased by up to 30%. The static and dynamic load carrying capacity has also been increased. At the same time, the stress placed on the mating track has been reduced as a result of the optimised surface profile and its improved surface quality.

Lower operating costs, higher machine availability

In conclusion, these advantages improve the overall cost-efficiency of the bearing position significantly and thus bring about a sustainable increase in the efficiency of the machine and equipment.

Suffix XL

X-life stud type track rollers include the suffix XL in the designation.

Stud type track rollers without eccentric collar

Stud type track rollers without an eccentric collar do not have a defined adjustment facility in relation to the mating track on the adjacent construction in mounting of the bearings.

Designs





The series KR and KR...-PP have a cage, the design KRV...-PP has a full complement needle roller set. Series NUKR has a full complement cylindrical roller set, series PWKR...-2RS has a full complement cylindrical roller set and a central rib ▶ 1385 | ⑧ 8 to ▶ 1386 | ⑧ 11.



! Bearings without a cage have the largest possible number of rolling elements and therefore have particularly high load carrying capacity. Due to the kinematic conditions, however, the speeds achievable with these bearings are somewhat lower than those achievable with the cage-guided stud type track rollers.

Axial guidance of outer ring

The type of guidance is dependent on the series

In KR, axial guidance is provided directly by the contact flange and contact washer, while in KR..-PP and KRV..-PP this is provided by plastic axial plain washers, the contact flange and contact washer **▶ 1385** |  8 and **▶ 1385** |  9. The outer rings of series NUKR and PWKR..-2RS are guided by the rolling elements and ribs **▶ 1386** |  10 and **▶ 1386** |  11.

Relubrication facility

! Stud type track rollers KR16 and KR19 with a hexagonal socket cannot be relubricated, while stud type track rollers KR16 and KR19 with a mounting slot have a relubrication facility.

Corrosion protection

Corrosion protection by Corrotect

Series PWKR(E)..-2RS-RR is protected against corrosion by the special Cr(VI)-free coating Corrotect **▶ 1389**. These bearings have the suffix RR.

 **8**
Stud type track roller without eccentric collar, with cage, sealed on both sides

F_r = radial load
 F_a = axial load

 Plastic axial plain washers (for KR..-PP) or gap seals (for KR)

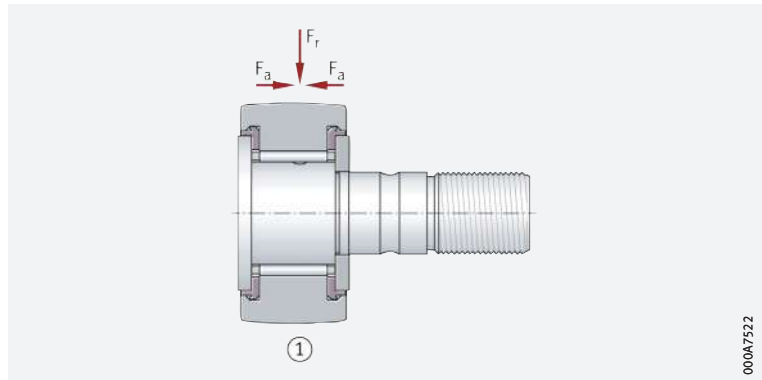

 **9**
Stud type track roller without eccentric collar, full complement needle roller set, sealed on both sides

F_r = radial load
 F_a = axial load

 Plastic axial plain washers (KRV..-PP)

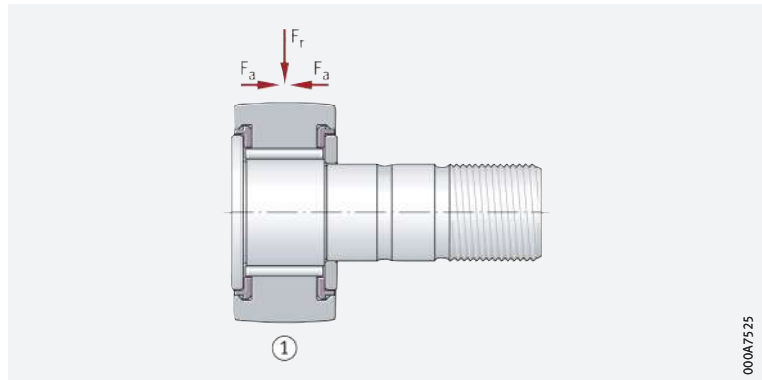

10

Stud type track roller without eccentric collar, full complement cylindrical roller set, sealed on both sides

F_r = radial load

F_a = axial load

① Labyrinth seals (NUKR)

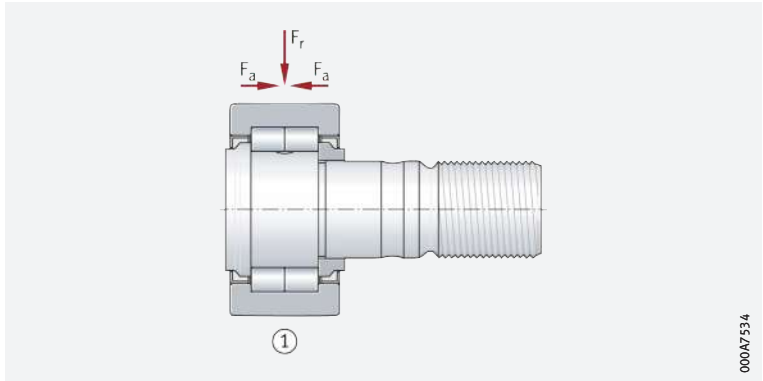

000A7534

11

Stud type track roller without eccentric collar, full complement cylindrical roller set, with central rib, sealed on both sides

F_r = radial load

F_a = axial load

① Protected lip seals (PWKR...-2RS)

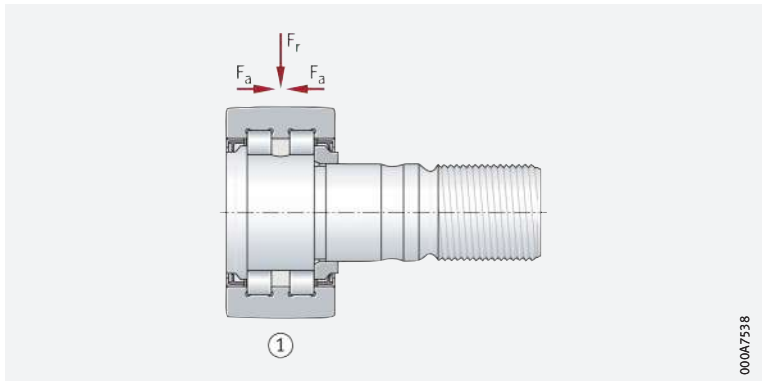

000A7538

Stud type track rollers with eccentric collar

☞ *The bearings have a defined adjustment facility relative to the mating track*

Designs with an eccentric collar can be adjusted by means of a hexagonal socket on the flanged or threaded side of the roller stud. The outer ring outside surface can thus be adjusted against the mating track. As a result, larger manufacturing tolerances can be tolerated in the adjacent construction. Furthermore, this gives improved load distribution when using several stud type track rollers and also allows preloaded linear systems to be easily realised.

☞ *Highest point of the eccentric collar*

The highest point of the eccentric collar is indicated on the roller stud side, the eccentricity e is stated in the product tables. This is also the location of the radial relubrication holes, which should lie in the unloaded zone of the rolling contact.

☞ *Designs*

Series KRE...-PP has a cage, NUKRE and PWKRE...-2RS have a full complement cylindrical roller set ➤ 1387|⊕ 12 to ➤ 1387|⊕ 14.



Bearings with a full complement cylindrical roller set have the largest possible number of rolling elements and therefore have particularly high load carrying capacity. Due to the kinematic conditions, however, the speeds achievable with these bearings are somewhat lower than those achievable with the cage-guided stud type track rollers.

☞ *The type of guidance is dependent on the series*

Axial guidance of outer ring

In the series KRE...-PP, axial guidance is provided by the plastic axial plain washers, contact flange and contact washers. In NUKRE, the outer ring is guided axially by the rolling elements, in PWKRE axial guidance of the outer ring is provided by the central rib and rolling elements.

12

Stud type track roller with eccentric collar, with cage, sealed on both sides

F_r = radial load
 F_a = axial load

- ① Plastic axial plain washers (KRE..-PP)

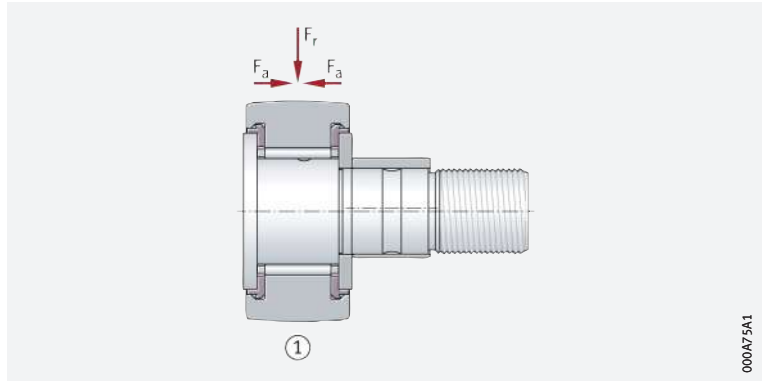

000A75A1

13

Stud type track roller with eccentric collar, full complement cylindrical roller set, sealed on both sides

F_r = radial load
 F_a = axial load

- ① Labyrinth seals (NUKRE)

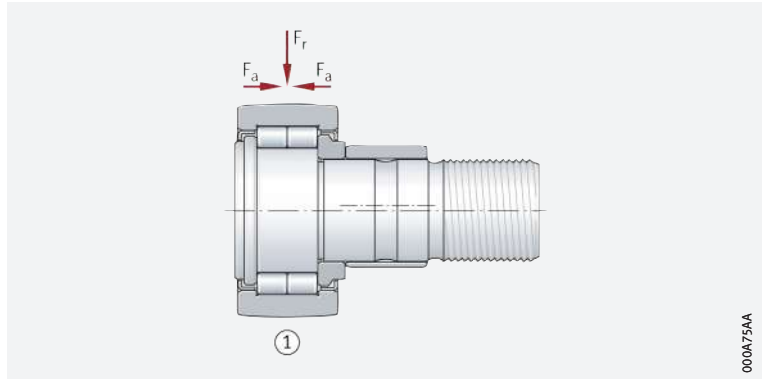

000A75A4

14

Stud type track roller with eccentric collar, full complement cylindrical roller set, with central rib, sealed on both sides

F_r = radial load
 F_a = axial load

- ① Protected lip seals (PWKRE..-2RS)

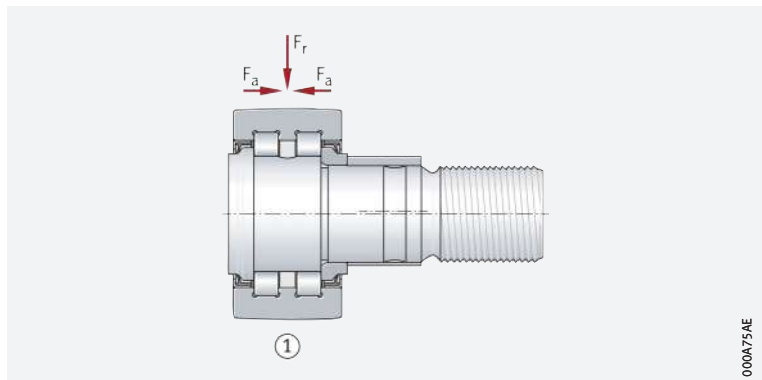

000A75A6



Optimised INA profile

Advantages

The advantages of the optimised INA profile are:

- lower Hertzian pressure under tilting ► 1388| 15 and ► 1388| 16
- higher basic rating life of the outer ring and mating track ► 1388| 17
- reduced wear between the outer ring outside surface and the mating track ► 1389| 18 and ► 1389| 19
- increased rigidity in the outer ring contact ► 1389| 20.

Hertzian pressure curve

Optimised INA profile, profile R = 500, cylindrical profile

The Hertzian pressure curve is more favourable for bearings with an optimised INA profile than for bearings with a cylindrical profile or with a profile where R = 500 mm (load $C_{rw}/P_r = 5$) ► 1388| 15.

15
Hertzian pressure curve

- ① Optimised INA profile
- ② Profile R = 500
- ③ Cylindrical profile
- ④ Untilted running, $\beta = 0$ mrad
- ⑤ Tilted running, $\beta = 3$ mrad

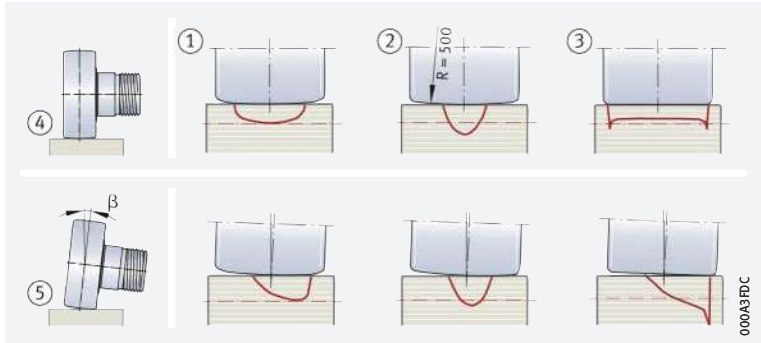

Reduced Hertzian pressure with optimised INA profile

Maximum Hertzian pressure

The maximum Hertzian pressure is significantly lower for bearings with an optimised INA profile than for bearings with a cylindrical profile or with the profile R = 500 mm **▶ 1388** | **16**.

16
Maximum Hertzian pressure, stud type track roller NUKR80, $F_r = 13\,800$ N ($C_{rw}/P_r = 5$)

p_H = maximum Hertzian pressure
 β = tilt angle

- ① Optimised INA profile
- ② Profile R = 500
- ③ Cylindrical profile

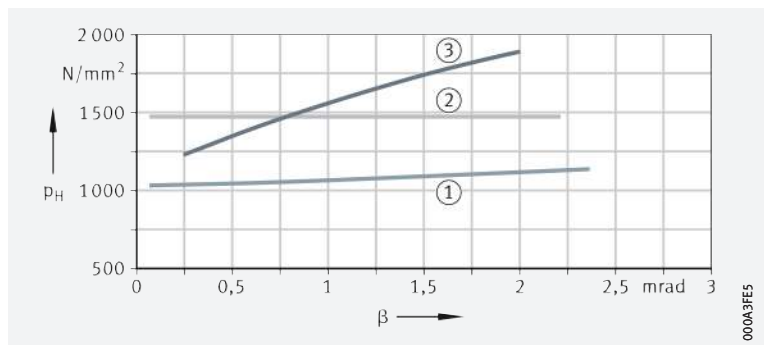

Longer rating life of mating track

Basic rating life of mating track

The rating life of the mating track is significantly longer for outer rings with an optimised INA profile than for bearings with the profile R = 500 mm **▶ 1388** | **17**. Yoke type track rollers NUTR15 **▶ 1389** | **18** were used as comparative bearings.

17
Basic rating life of the mating track, track made from 42CrMo4 V, hardness 350 HV

L = basic rating life in millions of overrolling motions
 F_r = radial load

- ① Optimised INA profile
- ② Profile R = 500

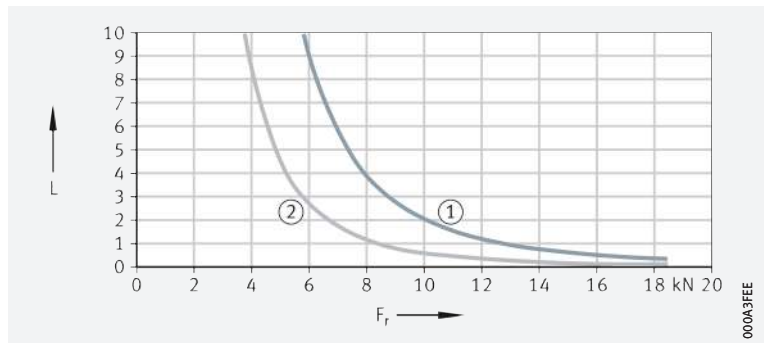

Reduced wear of the mating track

Wear of the mating track

The mating track wears to a lesser extent with the optimised INA profile **▶ 1389** | **18**: mating track made from EN-GJS-500-7, mean value derived from several test runs after 360 000 overrolling motions.

18

Wear of the mating track, track made from EN-GJS-500-7

- s_w = wear
- F_{r1} = low radial load
- F_{r2} = high radial load
- ① Optimised INA profile
- ② Profile $R = 500$

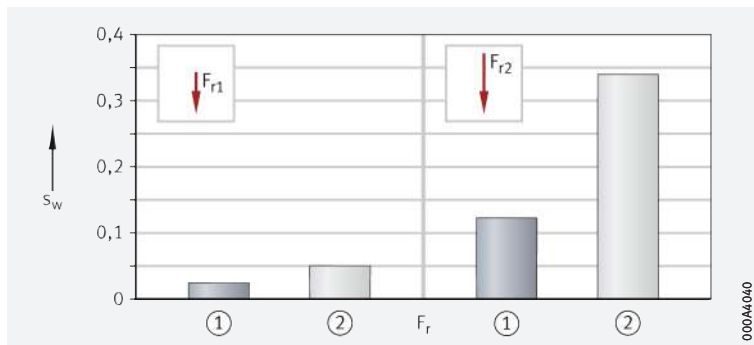

Mating track made from 58CrV4, mean value derived from several test runs after 800 000 overrolling motions [▶ 1389](#) | [19](#).

19

Wear of the mating track, track made from 58CrV4

- s_w = wear
- F_{r1} = low radial load
- F_{r2} = high radial load
- ① Optimised INA profile
- ② Profile $R = 500$

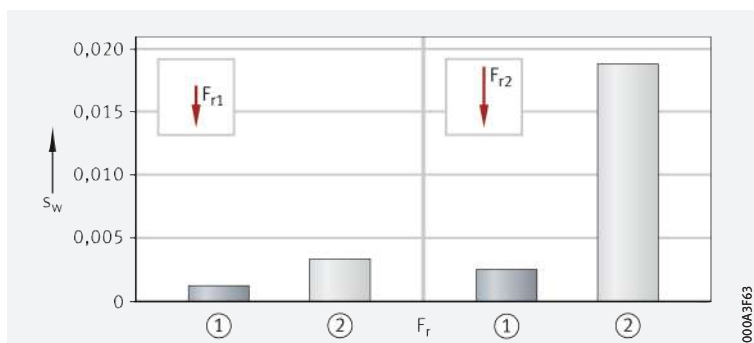

Radial deflection

Rigidity in outer ring contact

The radial deflection of the outer ring and rolling element set is smaller for bearings with an optimised INA profile than for bearings with the profile $R = 500$ mm [▶ 1389](#) | [20](#). Example, yoke type track roller NUTR15.



20

Rigidity in outer ring contact

- δ_r = radial deflection
- F_r = radial load
- ① Optimised INA profile
- ② Profile $R = 500$

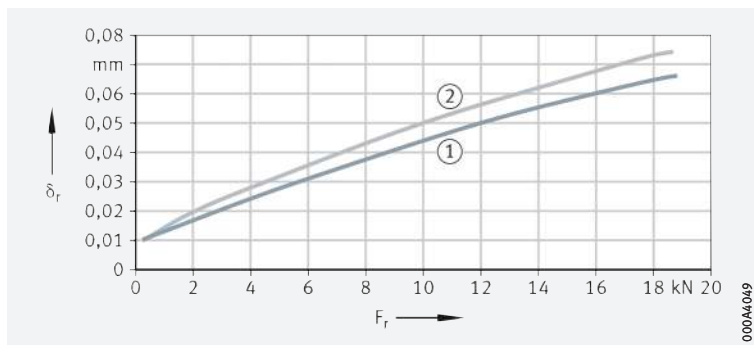

A Corrotect coating is often more economical than using corrosion-resistant steels

Corrosion protection by Corrotect

Track rollers are often subjected to aggressive media. In such applications, corrosion protection is therefore a decisive factor in achieving a long operating life of the bearings. In principle, corrosion-resistant steels may be used here. In many applications, however, the application of a special coating using available Corrotect thin film coating technology is more cost-effective and should therefore be queried in advance. The series PWTR..-2RS-RR and PWKR(E)..-2RS-RR are therefore available with a Corrotect coating. These bearings have the suffix RR [▶ 1398](#) | [1.12](#). Other series are also available as a special design with high performance Corrotect systems, which are matched to the specific application.



Before Corrotect-coated units are used, the compatibility of the coating with the existing media should always be checked.

Corrotect systems

Corrotect coating thicknesses

Corrotect methods are available which permit the application of an extremely thin coating and, as a result, do not need to be included in the bearing tolerance (0,5 µm to 3 µm or 2 µm to 5 µm). Increased demands on corrosion protection can be fulfilled with increasing coating thicknesses or completely different Corrotect methods. In isolated cases, dimensional changes resulting from the coating must be taken into account in a further processing step.

Cr(VI)-free coatings

The current Corrotect systems are all free from Cr(VI), protect effectively against corrosion and, as a result, extend the useful life of the Schaeffler components ▶ 1390 | 21.



Further detailed information on the modular coating tool box and on the individual coating systems can be found in Technical Product Information ▶ TPI 186 "Higher Performance Capacity through the Use of Coatings". This publication can be requested from Schaeffler.

Take account of larger tolerances

Fitting of Corrotect-coated bearings

The tolerances are increased by the thickness of the coating. In order to reduce the press-in forces, the surface of the parts should be lightly greased for fitting.



Uncoated and coated stud type track roller in the salt spray test



1.2 Load carrying capacity

Suitable for high radial loads

The bearings can support high radial loads. Yoke or stud type track rollers with axial guidance tolerate axial loads which are due to slight misalignments, skewed running or temporary contact running impacts.

If used as a yoke and stud type track roller, the outer rings undergo elastic deformation

Installation as yoke or stud type track roller

If the yoke and stud type track rollers are used on a flat mating track, the outer rings undergo elastic deformation. Compared with rolling bearings supported in a housing bore, yoke and stud type track rollers therefore have the following characteristics:

- modified load distribution in the bearing. This is taken into consideration by the effective basic load ratings C_{r_w} and C_{0r_w} used in the calculation of the rating life.
- bending stresses and reverse bending strengths in the outer ring. These are taken into consideration by the permissible effective radial loads $F_{r_{per}}$ and $F_{0r_{per}}$. The bending stresses and reverse bending strengths must not exceed the permissible strength values of the material.

☞ C_{rW} is valid For rotating bearings under dynamic load, the effective basic dynamic load rating C_{rW} is used. C_{rW} is used to calculate the basic rating life.

! The permissible dynamic radial load $F_{r\text{per}}$ must not be exceeded. If a value for $F_{r\text{per}}$ is not given, the effective basic dynamic load rating C_{rW} is used as a substitute. This basic load rating must also not be exceeded by the radial load present. If the basic static load rating C_{0rW} is lower than the basic dynamic load rating C_{rW} , then C_{0rW} applies.

☞ C_{0rW} is valid For bearings under static load, either stationary or with only infrequent rotary motion, the effective basic static load rating C_{0rW} applies. C_{0rW} is used to calculate the static load safety factor S_0 .

! The permissible basic static radial load $F_{0r\text{per}}$ must not be exceeded. If a value for $F_{0r\text{per}}$ is not given, the effective basic static load rating C_{0rW} is used as a substitute. This basic load rating must also not be exceeded by the radial load present. In addition to the permissible radial load of the bearing, the permissible radial load of the mating track must also be taken into consideration ► 1404.

1.3 Angular misalignment

☞ *Additional axial load under skewed running*

Skewed running leads to additional axial load on the rolling bearing and axial slippage in the rolling contact between the outer ring and mating track ► 1391 | ☐ 22. Depending on the skewed running angle α and the lubrication, wear can occur in these cases.

! A complete loss of adhesive friction between the outer ring and raceway, with correspondingly severe wear, is to be expected with a skewed running angle $\alpha \geq 1,4 \cdot 10^{-4} \cdot p_H$ (°) or $\alpha \geq 2,5 \cdot 10^{-3} \cdot p_H$ (mrad).



Skewed running

α = skewed running angle

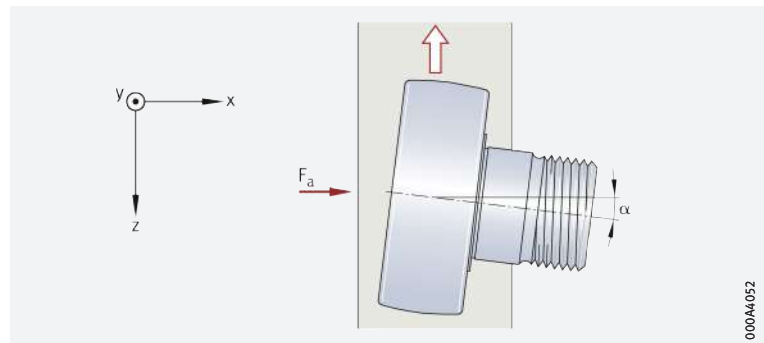

Tilting

☞ *Cylindrical outer ring* If tilting occurs during running, increased edge stresses occur, especially in yoke and stud type track rollers with cylindrical outer rings.

☞ *Crowned outer ring* Track rollers with a crowned outer ring are less sensitive to tilting and should therefore be used in preference.

☞ *Limits for tilting* In practice, track rollers with a cylindrical outside surface and a tilting angle of $\beta > 0,1^\circ$ (1,7 mrad) and for yoke and stud type track rollers with a crowned outside surface and a tilting angle of $\beta > 0,25^\circ$ (4,4 mrad) have proved susceptible to damage ► 1392 | ☐ 23.

23
Tilting

β = tilt angle

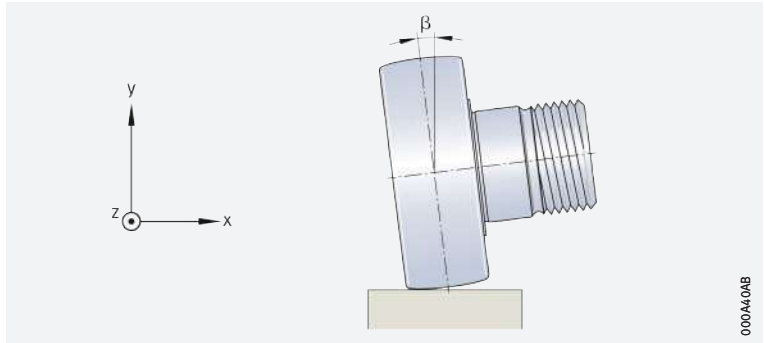

1.4 Lubrication

Lubricate the rolling elements, rolling element raceway and mating track



Two contact zones

- Two contact zones must be lubricated and considered separately:
 - the rolling elements and rolling element raceway
 - the outside surface of the track roller and the mating track.

The contact zone between the rolling elements and the rolling element raceway is covered in the chapter Technical principles, Lubrication.

Greased with a lubricating grease to GA08

Lubrication of the bearing

For yoke and stud type track rollers, a lithium complex soap grease with a mineral oil base and EP additives to GA08 is used. Yoke type track rollers can be lubricated via the inner ring, stud type track rollers have a type-dependent relubrication facility via the roller stud. Greases for initial greasing are listed in the chapter Lubrication > 90 | 6. For relubrication, greases in accordance with > 1392 | 1 are suitable.



In stud type track rollers with an eccentric collar, the eccentric collar covers the radial lubrication hole in the shank. Relubrication must therefore be carried out via the end faces.

1
Arcanol rolling bearing greases for relubrication

Arcanol grease	Designation to DIN 51825	Type of grease	Track roller
LOAD150	KP2N-20	Lithium soap grease with mineral oil base	Yoke and stud type roller bearing track rollers
LOAD220	KP2N-20	Lithium calcium soap grease with mineral oil base	Yoke and stud type roller bearing track rollers
MULTI3	KP3K-30	Lithium soap grease with mineral oil base	Yoke and stud type ball bearing track rollers

Lubrication of mating track

Suitable lubricants

For lubrication of the mating track, all lubricants suitable for rolling bearing lubrication may be used. However, there are applications in which the mating track must not be lubricated.



If the contact point cannot be lubricated, wear must be expected, especially under high loads and at high speeds.

Oil lubrication

For oil lubrication, oils of type CLP to DIN 51517 are recommended.

Grease lubrication

For grease lubrication, lithium soap greases to DIN 51825 should be used. Relubrication intervals can only be determined under operating conditions. Relubrication must be carried out at the latest when fretting corrosion first occurs; this can be identified by a reddish discoloration of the mating track or the outer ring.

Solid lubricants and anti-friction coatings

These substances are also suitable for lubrication. At high traverse or rotational speeds, however, they provide effective lubrication for a significantly shorter period than oil or grease lubrication.

Connection adapter with rapid-fit connection cartridge

Central lubrication system for stud type track rollers

If a central lubrication system is to be used, a patented central lubrication adapter can be used to connect the standard roller stud of stud type track rollers with hexagonal sockets on both sides ▶ 1393 | 24. This connector comprises a connection adapter with a hexagonal end and a rapid-fit connection cartridge.

The connection adapter is connected to the roller stud on one end of the stud type track roller by replacing the funnel type lubrication nipple with the fitting cylinder. The hexagonal end prevents rotation of the adapter. The other end of the stud type track roller is closed off using the supplied funnel type lubrication nipple ▶ 1393 | 24.



Central lubrication adapter and funnel type lubrication nipple

- ① Connection adapter with M10×1 internal thread
- ② Rapid-fit connection cartridge
- ③ Fitting cylinder
- ④ Funnel type lubrication nipple

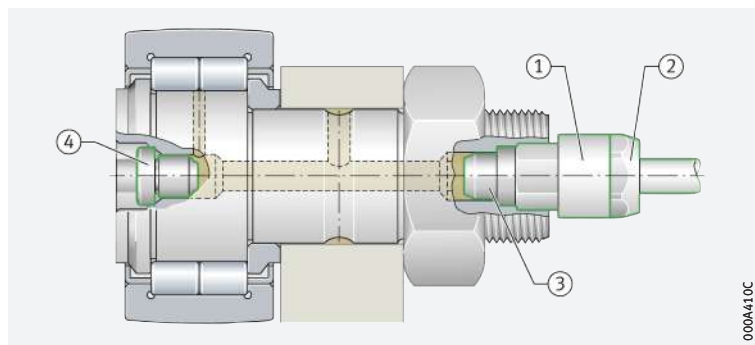

Hard PA pipes should be used in preference

The connection adapter has an M10×1 internal thread. This is used for screw mounting and sealing of the rapid-fit connection cartridge. The cartridge gives firm retention and sealing of the plastic pipe. It is therefore not necessary to screw the pipe and adapter onto each other. Hard PA pipes should be used in preference. In this instance, the operating limits according to DIN 73378 and the manufacturer's guidance must be observed. The maximum excess pressure for pipes made from PA11 or PA12 is as follows at +23 °C: 31 bar to 62 bar. The maximum excess pressure when using other screw-in connectors is 80 bar.



Dimensions



Dimensions of adapter

For dimensions of the adapters ▶ 1393 | 2 and ▶ 1394 | 25.

Central lubrication adapter	Dimensions					For polyamide pipe to DIN 73378 d ₁ × s _{nom}
	W	L	l ₁ max.	l ₂	l ₃ approx.	
AP8	8	27	16	22	4	4 × 0,75
AP10	10	27	15	22	5	4 × 0,75
AP14	14	25	8	20	6	4 × 0,75

25
 Dimensions
 of central lubrication adapters

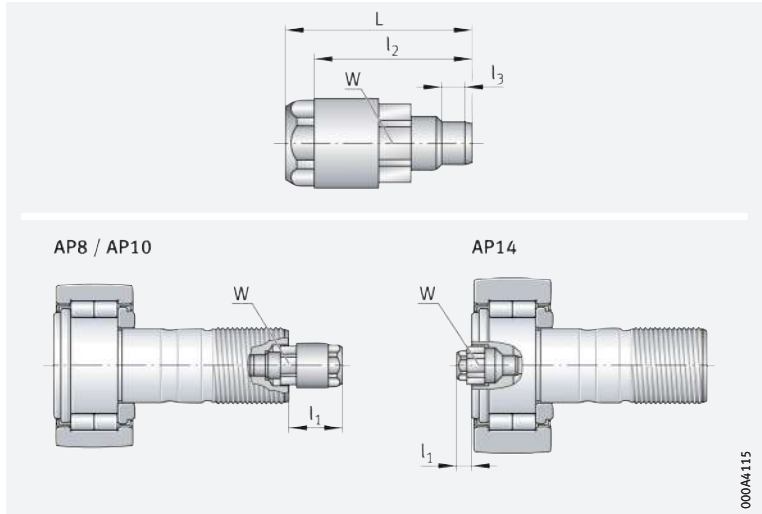

**Simplified determination
 of lubrication impulses**

Calculation of relubrication intervals

The relubrication quantities for central lubrication using flowable grease and their conversion to the number of relubrication impulses for conventional metering nipple sizes are given in the table ▶ 1394 | 3. The data are valid for EP additives, for a lithium soap flowable grease with a mineral oil base ISO VG 100 to ISO VG 220 or NLGI 00 or NLGI 000.

3
 Relubrication quantities
 for stud type track rollers

Series ¹⁾	Outside diameter		Central lubrication adapter Designation	Relubrication quantity ²⁾ g	Relubrication impulses for metering nipple of size	
	D mm				30 mm ³	50 mm ³
	from	up to				
NUKR, NUKRE	35	40	AP8	1,1	40	24
	47	52	AP10	2,4	89	53
	62	90	AP14	7,3	271	163
KR, KRE	35	40	AP8	1,2	44	27
	47	52	AP10	1,6	60	36
	62	90	AP14	6	222	133
KRV, KRVE	35	40	AP8	0,7	26	16
	47	52	AP10	1	37	22
	62	90	AP14	3,2	120	72

- 1) For stud type track rollers with hexagonal socket on both sides.
- 2) Relubrication quantity and relubrication intervals for central lubrication using flowable grease for the majority of applications. Note the quantity required to fill the feed lines.

Approximate definition

Relubrication periods

The approximate definition of the relubrication periods for single shift operation and the majority of applications is shown in ▶ 1394 | 4 and ▶ 1395 | 5. The data are valid for single shift operation; the relubrication quantity and relubrication intervals are valid for the majority of applications. They are based on approximate calculation of the relubrication interval t_{FR} . For definition of the relubrication interval see chapter Relubrication ▶ 70 | 6.1. Within these periods, the number of relubrication impulses determined in accordance with ▶ 1394 | 3 should be evenly distributed.

4
 Relubrication period
 for calculating
 the relubrication intervals

Load ratio C_{Orw}/P_r	Maximum operating speed n_{max} in % of n_{DG}			
	10	25	50	100
$5 > C_{Orw}/P_r \geq 3$	1/2 yearly	–	–	–
$10 > C_{Orw}/P_r \geq 5$	yearly	4 months	monthly	–
$C_{Orw}/P_r \geq 10$	yearly	8 months	2 months	14 days

5 Periods in single shift operation

Months	Weeks	Working days	Working hours
1/2	2	10	80
1	4	20	160
2	8	40	320
4	16	80	640
6	24	120	960
8	32	160	1 280
12	48	240	1 920

Mount the stud type track roller first

Fitting of central lubrication adapter

The stud type track roller must be mounted before fitting the adapter. The unused lubrication hole in the roller stud must be closed off using the funnel type lubrication nipple supplied. Only the lubrication nipples supplied should be used.

Guidelines for mounting of the adapter

The central lubrication adapter should preferably be pressed in using a manual lever press under low, uniform pressure or carefully driven into the unused hexagonal socket of the roller stud by means of light blows with a plastic hammer; pay attention to the press-in depth l_3 and the position of the hexagon ▶ 1394 | 25 and ▶ 1393 | 2.

Fitting of the polyamide pipe

The plastic pipe must be cut off straight across and inserted into the cartridge until it stops. Only polyamide pipes to DIN 73378 should be used. Check the seating of the pipe. Note maximum pressures, maximum temperatures and minimum bending radius. The maximum pipe length up to the distributor is 1 m.

1.5 Sealing

Available in open or sealed designs

Yoke type track rollers

Yoke type track rollers are available in open designs and with non-contact or contact type seals ▶ 1395 | 6.

6 Seals used in yoke type track rollers

Yoke type track roller	Seal
STO	Open
RSTO	
RNA22..-2RSR	Lip seal on both sides
NA22..-2RSR	
PWTR..-2RS	Protected lip seal on both sides
continued ▼	

6 Seals used in yoke type track rollers

Yoke type track roller	Seal
NATR..-PP	Three-stage sealing on both sides plastic axial plain washers
NATV..-PP	
NATR	Gap seal on both sides
NATV	
NUTR	Labyrinth seal on both sides
NNTR..-2ZL	Contact washer with lamellar ring on both sides
continued ▲	

Available with seals on both sides

Stud type track rollers

Stud type track rollers are sealed on both sides. Depending on the series, non-contact or contact type seals are used. A three-stage seal, comprising plastic axial plain washers with formed seal lips, is also used on both sides of the bearing ▶ 1396 | 7.



 **7**
Seals used in stud type track rollers

Stud type track roller	Seal
KR	Gap seal on both sides
KR...PP	Three-stage sealing on both sides by plastic axial plain washers
KRE...PP	
KRV...PP	
NUKR	Labyrinth seal on both sides
NUKRE	
PWKR...2RS	Protected lip seal on both sides
PWKRE...2RS	

Three-stage seal

 Seal design

In the three-stage concept, there is a gap seal between the plastic axial plain washer and the outer ring, as well as a labyrinth seal between the formed seal lip and an undercut in the outer ring. The disc spring shape of the axial plain washer gives a preloaded contact seal as the third stage. It also provides axial sliding contact between the outer ring and contact washers, thus reducing friction and grease consumption.

1.6 Speeds

 Speeds n_{DG}

The maximum possible speed is essentially determined by the permissible operating temperature of the yoke and stud type track rollers. The speed thus depends on the type of bearing, the load, the lubrication conditions and the cooling conditions.

Speeds with lip seals



The speed of track rollers with lip seals is additionally restricted by the permissible sliding speed at the seal lip.

Speed during continuous operation

 Criteria for guide values

The speeds n_{DG} in the product tables are guide values. They were determined for:

- grease lubrication
- loads during continuous operation of $< 0,05 \cdot C_{Orw}$
- skewed running angles of $\alpha < 0,03^\circ (< 0,5 \text{ mrad})$
- an ambient temperature of $+20 \text{ }^\circ\text{C}$
- outer ring temperatures of $+70 \text{ }^\circ\text{C}$
- lubricated mating tracks
- no external axial load.

 Reducing the speed

The speeds must be reduced under the following conditions:

- loads $> 0,05 \cdot C_{Orw}$
- additional axial forces (skewed running)
- insufficient heat dissipation.

 Higher speeds

Higher speeds can be achieved with intermittent operation and oil impulse lubrication.

1.7 Noise

Schaeffler Noise Index

The Schaeffler Noise Index (SGI) is not yet available for this bearing type ▶ 69. The data for these bearing series will be introduced and updated in stages.

Further information:

- **medias** ▶ <https://medias.schaeffler.com>.

1.8 Temperature range

Limiting values

The operating temperature of the yoke and stud type track rollers is limited by:

- the dimensional stability of the bearing rings and rolling elements
- the cage
- the lubricant
- the seals.

Permissible temperature ranges

Operating temperature	Yoke and stud type track rollers							
	Open or with gap seal or labyrinth seal		With lip seals 2RS, 2RSR		With plastic cages TV		With three-stage seal PP	
	from	to	from	to	from	to	from	to
°C								
	-30	+140	-30	+120	-30	+120	-30	+100



Note the information on the operating temperature range in the chapter Technical principles, Lubrication.



In the event of anticipated temperatures which lie outside the stated values, please contact Schaeffler.

1.9 Cages

Yoke type track rollers

Yoke type track rollers without inner ring

With cage

Yoke type track rollers RSTO and RNA22..-2RSR have a sheet steel cage as standard. Yoke type track rollers RSTO up to D = 24 mm have a plastic cage made from polyamide PA66 (suffix TV). Series RSTO does not have axial guidance of the needle roller and cage assembly and of the outer ring. As a result, lateral guidance is required.



Yoke type track rollers with inner ring

With cage, with full complement needle roller or cylindrical roller set

The series STO, NA22..-2RSR, NATR and NATR..-PP have a sheet steel cage as standard. Yoke type track rollers STO up to D = 24 mm have a plastic cage made from polyamide PA66 (suffix TV). The series NATV and NATV..-PP have a full complement needle roller set, while yoke type track rollers NUTR, PWTR..-2RS and NNTR..-2ZL have a full complement cylindrical roller set. Series STO does not have axial guidance of the needle roller and cage assembly and of the outer ring. As a result, lateral guidance is required.

Stud type track rollers

Stud type track rollers without eccentric collar

With cage, with full complement needle roller or cylindrical roller set

Axial guidance of outer ring

Stud type track rollers KR and KR..-PP have a sheet steel cage, the design KRV..-PP has a full complement needle roller set. The series NUKR and PWKR..-2RS have a full complement cylindrical roller set.

In KR, axial guidance is provided directly by the contact flange and contact washer, while in KR..-PP and KRV..-PP this is provided by plastic axial plain washers, the contact flange and contact washer. In NUKR, the outer ring is guided axially by the rolling elements, in PWKR, axial guidance of the outer ring is provided by the central rib and rolling elements.

Stud type track rollers with eccentric collar

With cage or full complement cylindrical roller set

Axial guidance of outer ring

Series KRE..-PP has a sheet steel cage, NUKRE and PWKRE..-2RS have a full complement cylindrical roller set.

In KRE..-PP, axial guidance is provided by the plastic axial plain washers, contact flange and contact washer. In NUKRE, the outer ring is guided axially by the rolling elements, in PWKRE, axial guidance of the outer ring is provided by the central rib and rolling elements.

1.10 Internal clearance

Standard corresponds approximately to C2 or CN

Radial internal clearance

The radial internal bearing clearance of yoke and stud type track rollers corresponds approximately to tolerance class C2 (Group 2) and, in the case of STO and NA22...-2RSR, to tolerance class CN (Group N). Values ▶ 1398 | 9.



The values for radial internal clearance correspond to DIN 620-4:2004 (ISO 5753-1:2009). These are valid for bearings which are free from load and measurement forces (without elastic deformation).

Radial internal clearance for yoke and stud type track rollers

Nominal bore diameter d mm		Radial internal clearance							
		C2 (Group 2)		CN (Group N)		C3 (Group 3)		C4 (Group 4)	
over	incl.	μm		μm		μm		μm	
		min.	max.	min.	max.	min.	max.	min.	max.
–	24	0	25	20	45	35	60	50	75
24	30	0	25	20	45	35	60	50	75
30	40	5	30	25	50	45	70	60	85
40	50	5	35	30	60	50	80	70	100
50	65	10	40	40	70	60	90	80	110
65	80	10	45	40	75	65	100	90	125
80	100	15	50	50	85	75	110	105	140
100	120	15	55	50	90	85	125	125	165
120	140	15	60	60	105	100	145	145	190

1.11 Dimensions, tolerances

Tolerances



The dimensional and running tolerances correspond to the tolerance class Normal in accordance with ISO 492, for KR, KRE and KRV to ISO 7063.

Deviations from ISO 492

The following deviations from ISO 492 apply:

- the diameter deviations of the profiled outside surface 0/–0,05 mm
- for NNTR, the diameter tolerance class h10
- for NATR, NATV, NUTR, PWTR...-2RS, the tolerance class h12 for width B
- for NATR, NATV, the roundness of the inner ring
- for stud type track rollers, the tolerance class of the shank diameter h7 and the eccentric collar diameter h9.

Tolerances for Corrotect-coated bearings

For PWTR...-2RS-RR and PWKR...-2RS-RR, the tolerances are increased by the thickness of the Corrotect special coating.

Enveloping circle

Yoke type track rollers without inner ring

For yoke type track rollers without an inner ring, RSTO and RNA22...-2RSR, the needle enveloping circle F_w is in the tolerance class F6. The enveloping circle is the inner inscribed circle of the needle rollers in clearance-free contact with the adjacent construction.

1.12 Suffixes

For a description of the suffixes used in this chapter ▶ 1399 | 10 and **medias** interchange ▶ <https://www.schaeffler.de/std/1D52>.

10
 Suffixes and corresponding descriptions

Suffix	Description of suffix	
PP	Plastic axial plain washer with formed seal lip on both sides of the bearing, giving a three-stage seal	Standard
RR	Protected against corrosion by Corroprotect special coating in the case of PWTR...-2RS and PWKR(E)...-2RS	
SK	Hexagonal socket only on the flange-side end face, no relubrication facility	
TV	Plastic cage	
XL	X-life design	
2RS	Protected lip seal on both sides	
2RSR	Radial contact lip seal on both sides	
2ZL	Contact washer with lamellar ring on both sides	

1.13 Structure of bearing designation

Examples of composition of bearing designation

The designation of bearings follows a set model. Examples ▶ 1399 | 26 to ▶ 1399 | 29.

26
 Yoke type track roller, single row, without inner ring, without seal, without axial guidance, open design, plastic cage, R = 500: designation structure



000B1132

27
 Yoke type track roller, double row, with inner ring, sealed, with axial guidance, optimised INA profile: designation structure

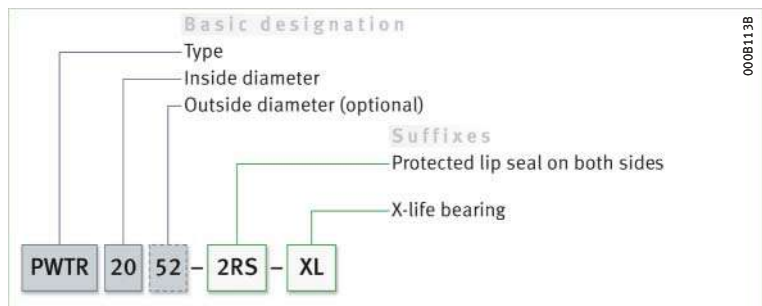

000B113B



28
 Stud type needle roller bearing track roller, full complement needle roller set, with axial guidance, three-stage seal, optimised INA profile: designation structure

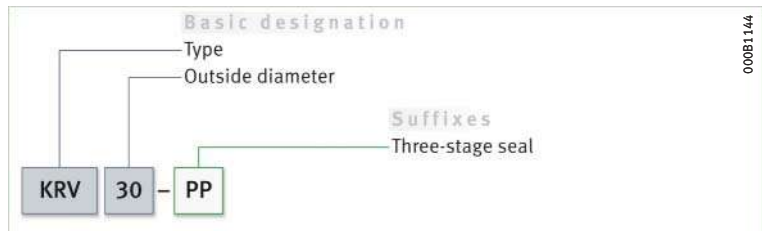

000B1144

29
 Stud type cylindrical roller bearing track roller, full complement cylindrical roller set, with axial guidance, X-life design, optimised INA profile: designation structure

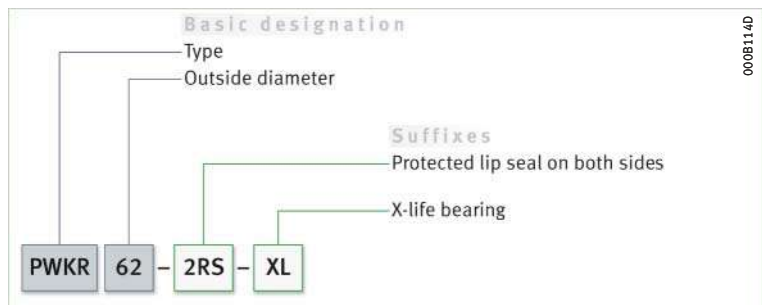

000B114D

1.14 Dimensioning

Calculation of the rating life

The methods for calculating the rating life are:

- the basic rating life to DIN ISO 281
- the adjusted basic rating life to DIN ISO 281
- the expanded calculation of the adjusted reference rating life to DIN ISO 281-4.

Use effective basic dynamic/static load ratings

These methods are described in the chapter Load carrying capacity and life. For yoke and stud type track rollers, use the following values (values > 1416):

- for C_r , the effective basic dynamic load rating C_{rW}
- for C_{0r} , the effective basic static load rating C_{0rW}
- for C_{ur} , the effective fatigue limit load C_{urW} .

Other rating life equations

Other equations for calculating the rating life > 1400 | f1, > 1400 | f2 and > 1400 | f3.

f1 Basic rating life

$$L_s = 0,0314 \cdot D \cdot \left(\frac{C_{rW}}{P_r} \right)^p$$

f2 Basic rating life in oscillating operation

$$L_h = 26,18 \cdot \frac{D}{H \cdot n_{osc}} \cdot \left(\frac{C_{rW}}{P_r} \right)^p$$

f3 Basic rating life

$$L_h = 52,36 \cdot \frac{D}{\bar{v}} \cdot \left(\frac{C_{rW}}{P_r} \right)^p$$

Legend

L_s	10^5 m	Basic rating life in 10^5 m
L_h	h	Basic rating life in operating hours
C_{rW}	N	Effective basic dynamic load rating. C_{rW} is that load of constant magnitude and direction which a sufficiently large group of apparently identical track rollers can endure for a basic rating life of one million revolutions
P_r	N	Equivalent dynamic bearing load (radial load)
p	-	Life exponent: $p = 3$ for yoke or stud type track rollers based on balls $p = 10/3$ for yoke and stud type track rollers based on needle or cylindrical rollers
n	min^{-1}	Operating speed
D	mm	Outside diameter of track roller
H	m	Single stroke length for oscillating motion
n_{osc}	min^{-1}	Number of return strokes per minute
\bar{v}	m/min	Mean travel velocity.

Operating life

Life actually achieved

The operating life is defined as the life actually achieved by a yoke type track roller, stud type track roller or ball bearing track roller. This can deviate significantly from the calculated basic rating life.

☞ **Cause of deviations** Possible causes of a deviation between the basic rating life and the operating life are wear or fatigue as a result of:

- deviations in the operating data
- misalignment between the track roller and mating track
- insufficient or excessive operating clearance
- contamination of the track roller
- inadequate lubrication
- excessive operating temperature
- oscillating bearing motion with very small swivel angles, leading to false brinelling
- wear between the outer ring outside surface and mating track
- high vibration and false brinelling
- very high shock loads, static overloading
- prior damage during mounting.



Due to the variety of mounting and operating conditions, the operating life cannot be precisely calculated in advance. The most reliable way of arriving at a close estimate is by comparison with similar applications.

Static load safety factor

☞ $S_0 = C_{Orw}/F_{Or}$ In addition to the basic rating life L, it is also always necessary to check the static load safety factor S_0 ▶ 1401 | f1 4.

f1 4
Static load safety factor

$$S_0 = \frac{C_{Orw}}{F_{Or}}$$

Legend

S_0	–	Static load safety factor
C_{Orw}	N	Effective radial basic static load rating in accordance with product table
F_{Or}	N	Maximum static radial load on track roller.



Track rollers are regarded as heavily loaded at a static load safety factor of $S_0 < 8$. Static load safety factors of $S_0 < 1$ cause plastic deformation of the rolling elements and the raceways, which can impair smooth running. This is only permissible for bearings with small rotary motions or in secondary applications.



If an application has a static load safety factor of $S_0 < 2$, please consult Schaeffler.



Frictional torque

☞ **Calculation only possible in approximate terms**

The frictional torque M_R of a yoke type, stud type or ball bearing track roller depends on many influencing factors such as load, speed and type, as well as the lubrication conditions and seal friction. Due to the wide range of these influencing factors, the frictional torque can only be calculated approximately.

For designs without contact seals, the frictional torque can be calculated under normal operating conditions and moderate speed range in accordance with ▶ 1401 | f1 5.

f1 5
Frictional torque

$$M_R = f \cdot F_r \cdot \frac{d_M}{2}$$

Legend

M_R	Nmm	Frictional torque of track roller
f	–	Coefficient of friction ▶ 1402 11 and ▶ 1402 12
F_r	N	Radial load
d_M	mm	Mean bearing diameter of track roller $(d + D)/2$.

11
Coefficient of friction
for yoke and stud type track rollers

Type	Coefficient of friction f
Cylindrical roller bearing, full complement	0,002 to 0,003
Needle roller bearing, with cage	0,003 to 0,004
Needle roller bearing, full complement	0,005 to 0,007

12
Coefficient of friction
for track rollers

Type	Coefficient of friction f
Ball bearing, single row	0,0015 to 0,002
Ball bearing, double row	0,002 to 0,003

Validity
of coefficients of friction

The stated factors f are valid for yoke type, stud type and ball bearing track rollers, which are unsealed or have a contact seal and are subjected to radial load. If sealed designs are used, higher coefficients of friction must be expected.

Influence
of additional axial forces

Additional axial forces, such as those occurring under large skewed running angles, can lead to a substantial increase in the values, especially in the case of track rollers based on needle rollers. Track rollers based on ball bearings can support axial loads without a significant change in friction.

Displacement resistance

When an outer ring rolls on a track, it must overcome not only the friction within the bearing but also the rolling friction between the outer ring and the mating track. The displacement resistance is determined from the rolling friction and the frictional torque M_R in accordance with **1402** | **16**.

16
Displacement resistance

$$F_v = \frac{2 \cdot (f_R \cdot F_r + M_R)}{D}$$

Legend

F_v	N	Displacement resistance
f_R	mm	Coefficient of rolling friction for tracks made from hardened steel: $f_R = 0,05$ mm
F_r	N	Radial load
M_R	Nmm	Frictional torque
D	mm	Outside diameter of track roller.

1.15 Minimum load

Minimum load
 $C_{Orw}/F_r < 60$

In order to ensure that the outer ring is driven, that no slippage occurs and that the track roller does not lift from the mating track, the track roller must be subjected to a minimum load in dynamic operation. In general, the minimum load is calculated using the ratio $C_{Orw}/F_r < 60$.

1.16 Design of bearing arrangements

Adjacent construction for yoke type track rollers

Yoke type track rollers
without inner ring,
raceway design

For yoke type track rollers without an inner ring, the rolling element raceway on the shaft or stud must be hardened and ground **1402** | **13**. The surface hardness must be 670 HV to 840 HV, the hardening depths CHD or SHD must be sufficiently large.

13
Tolerances and surface design

Diameter tolerance of shafts or studs		Roughness	Roundness tolerance	Parallelism tolerance
Without inner ring	With inner ring			
k5 [Ⓔ]	g6 [Ⓔ] (with point load)	Ramax 0,4 (Rzmax 2)	max. 25% of diameter tolerance	max. 50% of diameter tolerance

Location of yoke type track rollers without axial guidance

! For yoke type track rollers without axial guidance, the outer ring and needle roller and cage assembly must be laterally guided ▶ 1403 | 30. The contact surfaces for the outer rings must be precision machined, wear-resistant and lubricated (Ramax 2 recommended).

⚙️ Bearing parts must not be interchanged with parts from other bearings during fitting

Yoke type track rollers without axial guidance are not self-retaining. The outer ring and the needle roller and cage assembly are matched to each other and must not be interchanged during mounting with components from other bearings of the same size. The inner rings are matched to the enveloping circle tolerance class F6 and can be interchanged within their accuracy class (used in different combinations).

30
Lateral guidance of outer ring and needle roller and cage assembly

① RSTO

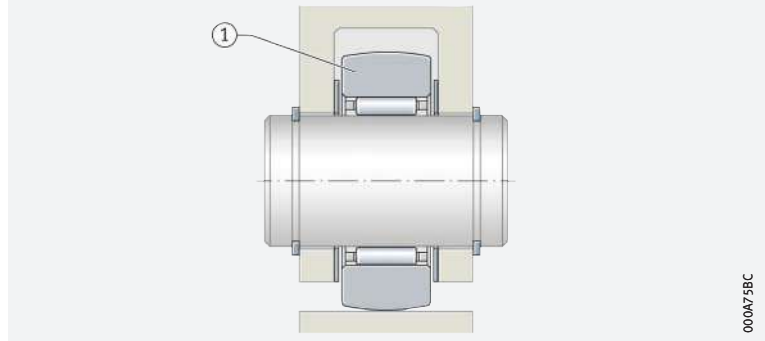

000A75BC

Location of yoke type track rollers with axial guidance

⚙️ Observe dimension d_2 Yoke type track rollers with axial guidance must be axially clamped in place. The thrust washers must be axially supported if axial loads occur. The dimension d_2 in the product tables must be observed ▶ 1403 | 31.

⚙️ Location by snap ring Yoke type track rollers NATR and NATV can be located using conventional fasteners such as snap rings ▶ 1403 | 31.

31
Location by snap ring

d_2 = abutment diameter

① NATR
② Snap ring

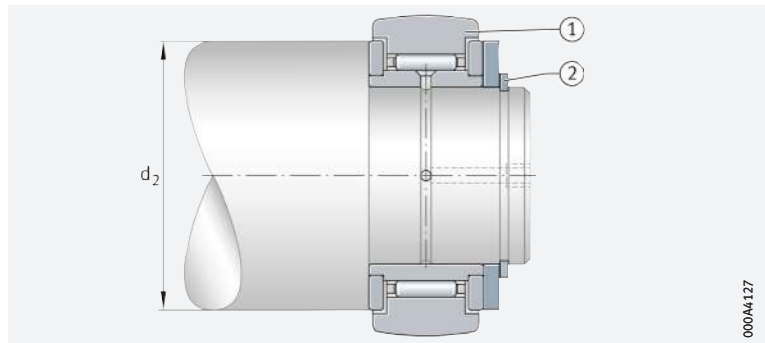

000A4127

⚙️ Firmly locate inner ring and thrust rings axially For yoke type track rollers NNTR..-2ZL, NUTR and PWTR..-2RS, the inner ring and thrust rings must be located axially ▶ 1403 | 32.

32
Clamping of inner ring and thrust rings

① PWTR..-2RS

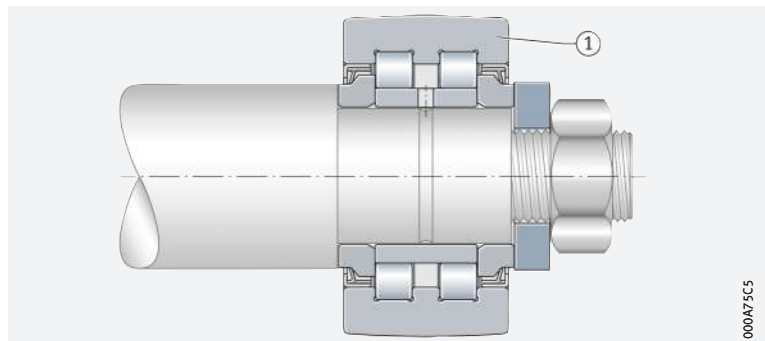

000A75C5

Adjacent construction for stud type track rollers

- 🔗 **Bore tolerance H7** The bore tolerance H7 produces a clearance fit since the stud tolerance is h7 for studs without eccentric collar and h9 for studs with eccentric collar.
- 🔗 **Design of locating surfaces** The locating surfaces for stud type track rollers must be flat, perpendicular and of sufficient height. The strength of the nut locating surface must be sufficiently high. The dimension must not be less than the dimension d_2 in the product tables.
- 🔗 **Lead chamfer** The lead chamfer on the locating bore must not be more than $0,5 \times 45^\circ$.

Axial location

- 🔗 **Axial location** Stud type track rollers must be axially secured using a hexagon nut. The nuts of grade 8 to ISO 4032 (M6, M8), ISO 8673, are not included in the delivery and must be ordered separately.
- If heavy vibration occurs, the stud type track rollers can be located using self-locking nuts in accordance with DIN 985 or special locking washers.
- ! For self-locking nuts, a higher tightening torque must be observed; the advice given by the nut manufacturer must be followed.

Position of lubrication hole



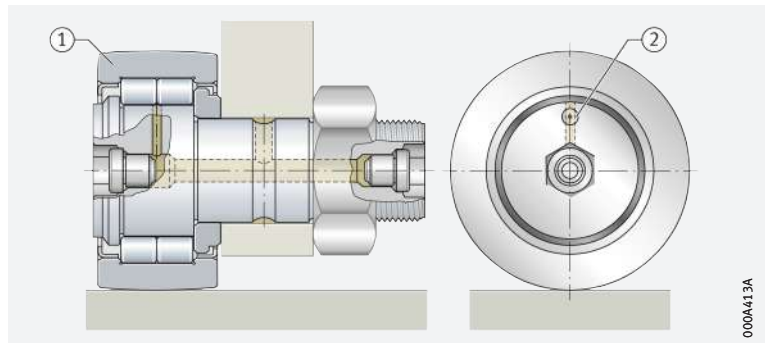

- 🔗 **Ensure that the lubrication hole is positioned correctly** The position of the radial lubrication hole is indicated on the flanged side of the roller stud ➤ 1404 |  33. This must not be positioned in the loaded zone.

 **33**
Position of lubrication hole

- ① NUKR
- ② Marking (position of radial lubrication hole)



Design of mating track

- 🔗 **Take account of Hertzian pressure** In the design of the mating track (material and strength, heat treatment, surface), the Hertzian pressure p_H must be taken into consideration. This is dependent on the load, the contact geometry (point contact or line contact) and the modulus of elasticity of the materials.
- 🔗 **Nomogram for determining the Hertzian pressure** The Hertzian pressure can be read from the nomogram and calculated ➤ 1406 |  35. The nomogram is valid for mating tracks made from steel. For other materials, the correction factor k must be taken into consideration ➤ 1407 |  15.
- 🔗 **Additional conditions** Other conditions:
 - point contact
 - radius of curvature $R = 500$. For radii $R > 500$ and the optimised INA profile, correction values must be calculated ➤ 1407 |  10
 - mating track flat in the direction of the track roller axis
 - signs according to ➤ 1405 |  34.

34

Raceway radii and signs

D = outside diameter
of track roller

r_L = raceway radius

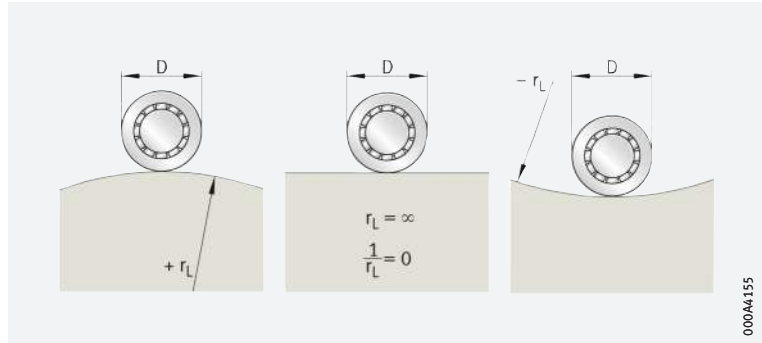

000AA155

Example

🔗 **NUKR35**

- stud type track roller NUKR35 with optimised INA profile
- $D = 35$ mm
- outer ring width $C = 18$ mm
- radial load $F_r = 2\,500$ N
- cam plate, radius $r_L = 80$ mm.

Curvature sum

🔗 **Calculating the curvature sum**

The curvature sum is calculated from the raceway radius r_L and the diameter D of the track roller ▶ 1405 | f7.

f7
Curvature sum

$$\frac{1}{r_L} + \frac{2}{D} = \frac{1}{80} + \frac{2}{35} = 0,07 \text{ mm}^{-1}$$

$$p_{H500} = 1\,250 \text{ N/mm}^2$$

f8
Hertzian pressure

$$p_{H \text{ opt. INA profile}} \approx 1\,250 \text{ N/mm}^2 \cdot k_{pH}$$

$$= 1\,250 \text{ N/mm}^2 \cdot 0,85$$

$$= 1\,063 \text{ N/mm}^2$$

(1 025 N/mm² from calculation program BEARINX),

$$k_{pH} \text{ ▶ } 1406 | \text{ 14.}$$



35 Nomogram for determining Hertzian pressure, calculation example (purple)

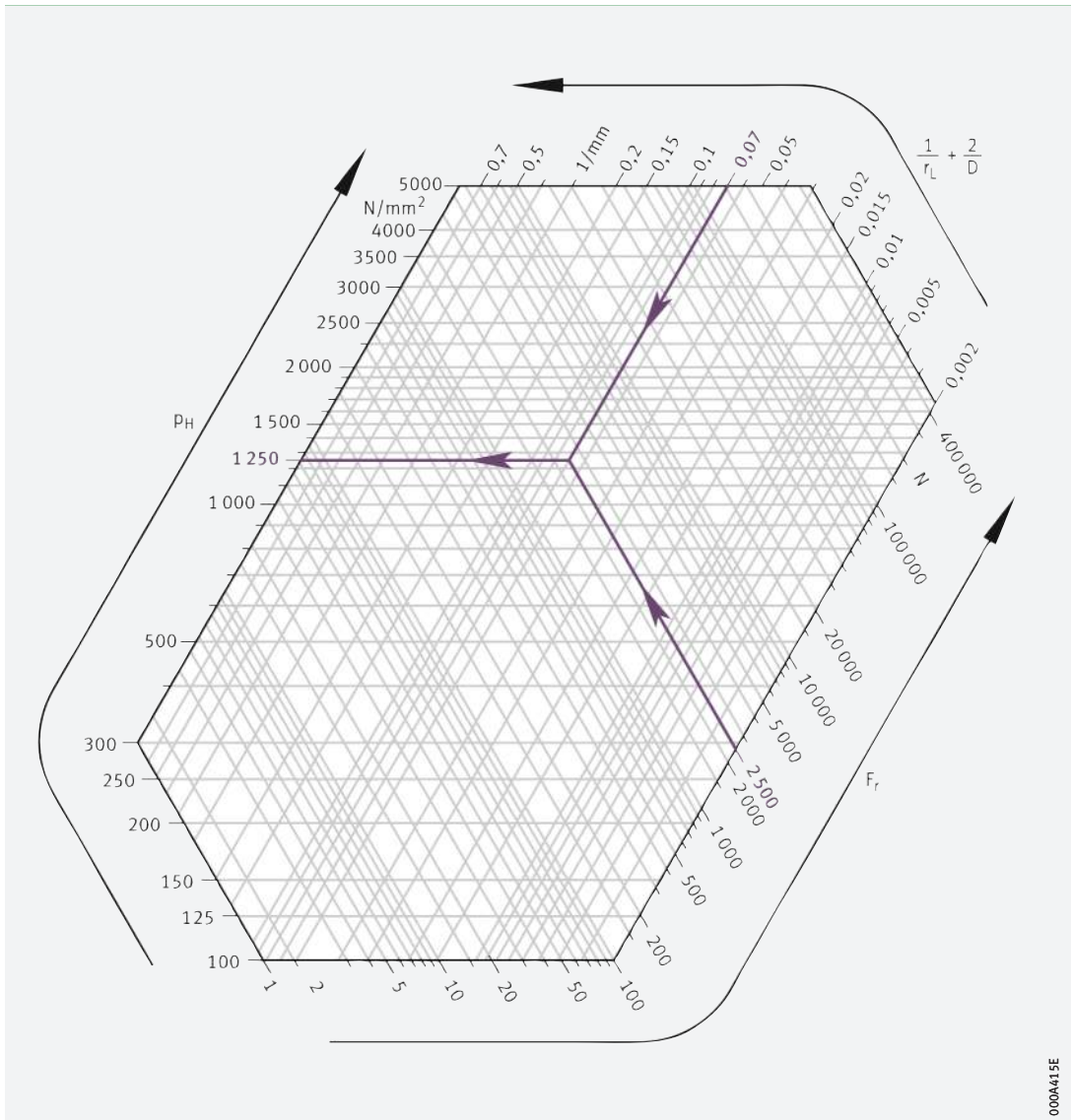

9 Track rollers with optimised INA profile

For an outer ring with the optimised INA profile, the following calculation provides sufficiently precise values $\blacktriangleright 1406 \text{ } \overset{\text{f}}{\text{9}}$ and $\blacktriangleright 1406 \text{ } \overset{\text{14}}{\text{14}}$.

9 Optimised INA profile

$$p_{H \text{ opt. INA profile}} \approx k_{pH} \cdot p_{H500}$$

14 Pressure factor k_{pH}

Outer ring width C mm	Pressure factor k_{pH}
$10 \leq C \leq 15$	1
$15 < C \leq 20$	0,85
$20 < C \leq 30$	0,83
$30 < C \leq 35$	0,8

Radius of curvature $R > 500$ mm

If the outer ring has a radius of curvature of $R > 500$ mm, ► 1407 | f 10.

f 10
 $R > 500$ mm

$$p_{HR} = p_{H500} \cdot \left(\frac{500}{R} \right)^{0,185}$$

Materials for mating track

High load
on the mating track

The mating track is subjected to high load during overrolling. This produces high Hertzian contact pressures. The strength and surface hardness of the material must be matched to this load.

Correction factors

For raceways subjected to high loads, through hardened steels, case hardened steels and steels for flame or induction hardening are recommended. For raceways subjected to low loads, construction steels and cast steel or cast iron materials can be used ► 1407 | f 11 ► 1407 | 15.

f 11
Correction
for mating track material

$$p_H = k \cdot p_H(\text{steel/steel})$$

15
Correction factor k

Material	Material no.	Correction factor for mating track with k	
		for point contact	for line contact
EN-GJL-200	0.6020	0,74	0,8
EN-GJL-300	0.6030	0,81	0,85
GG-40	–	0,85	0,88
EN-GJS-400-15	0.7040	0,92	0,94
EN-GJS-600-3	0.7060	0,94	0,96
EN-GJS-800-2	0.7080	0,96	0,97

Selection by material

Guide values for permissible Hertzian pressure

The table ► 1408 | 16 gives a selection of materials with the associated values. The values were determined on steel test specimens; load cycles of 10^7 were achieved.

On a similar basis to the calculation of the load carrying capacity of rolling bearings, this gives:

- $p_{H \text{ stat}}$ for predominantly static load
- $p_{H \text{ dyn}}$ for predominantly dynamic load.



16

Materials and guide values for permissible Hertzian pressure (selection)

Material	Material designation		Material no.		Hertzian pressure		Proof stress of material R _{p0,2} N/mm ²
	new	old			PH stat N/mm ²	PH dyn N/mm ²	
Flake graphite cast iron	EN-GJL-150	GG-15	EN-JL1020	0.6015	850	340	120
	EN-GJL-200	GG-20	EN-JL1030	0.6020	1 050	420	150
	EN-GJL-250	GG-25	EN-JL1040	0.6025	1 200	480	190
	EN-GJL-300	GG-30	EN-JL1050	0.6030	1 350	540	220
	EN-GJL-350	GG-35	EN-JL1060	0.6035	1 450	580	250
	GG-40		–		1 500	600	280
Spheroidal graphite cast iron	EN-GJS-400-15	GGG-40	EN-JS1030	0.7040	1 000	490	250
	EN-GJS-500-7	GGG-50	EN-JS1050	0.7050	1 150	560	320
	EN-GJS-600-3	GGG-60	EN-JS1060	0.7060	1 400	680	380
	EN-GJS-700-2	GGG-70	EN-JS1070	0.7070	1 550	750	440
	EN-GJS-800-2	GGG-80	EN-JS1080	0.7080	1 650	800	500
Cast steel	GE200	GS-38	1.0420		780	380	200
	GE240	GS-45	1.0446		920	450	230
	GS-52		1.0552		1 050	510	260
	GE300	GS-60	1.0558		1 250	600	300
	GS-62		–		1 300	630	350
	GS-70		–		1 450	700	420
Construction steel	S235JR	St 37-2	1.0037		690	340	235
	S275JR	St 44-2	1.0044		860	420	275
	S355J2G3+N	St 52-3	1.0570		980	480	355
Quenched and tempered steel	C45 V		1.0503		1 400	670	500
	Cf53 V		1.1213		1 450	710	520
	Cf56 V		–		1 550	760	550
	C60 V		1.0601		1 600	780	580
	46Cr2 V		1.7006		1 750	850	650
	42CrMo4 V		1.7225		2 000	980	900
	50CrV4 V		1.8159		2 000	980	900
Hardened steel and with tempering at low temperatures	100Cr6 H		1.3505		4 000	1 500	1 900
	16MnCr5 ¹⁾		1.7131		4 000	1 500	770 ³⁾
	Cf53 ²⁾		1.1213		4 000	1 500	730 ³⁾
	Cf56 ²⁾		–		4 000	1 500	760 ³⁾

1) Case hardened.

2) Induction surface layer hardening.

3) Proof stress of the core.

Hardenable materials



The following materials with a purity level corresponding to that of alloyed construction steels may be used:

- through hardening steels to ISO 683-17, such as 100Cr6.
In special cases, surface hardening is possible.
- case hardening steels to ISO 683-17, such as 17MnCr5, or in accordance with EN 10084, such as 16MnCr5. Both the hardenability and the core strength must be taken into consideration. For case hardening, a fine grained hardening structure and a case hardening depth CHD in accordance with ► 1409 | § 12 is necessary.
- steels for flame or induction hardening to ISO 683-17, such as C56E2, or to DIN 17212, such as Cf53. For flame or induction hardening, only the parts of the machine component used as raceways must be hardened. The material should be quenched and tempered before hardening. The surface hardening depth SHD is determined in accordance with ► 1409 | § 13.

Specifications for heat treatment

Heat treatment of the mating track

The following apply for hardened mating tracks:

- a surface hardness of 670 HV to 840 HV
- CHD and SHD according to ►1409|f12 and ►1409|f13 – in accordance with DIN 50190, the depth of the hardened surface zone at which there is still a hardness of 550 HV
- hardness curves according to ►1409|q36 and ►1409|q37
- a hardening depth of $\geq 0,3$ mm.

The equations are based on the hardness curves normally achieved with skilled heat treatment.

Case hardening

f12
Case hardening depth

$$CHD \cong 2,73 \cdot 10^{-5} \cdot \frac{p_H}{\left(\frac{1}{r_L} + \frac{2}{D}\right)}$$

Flame and induction hardening

f13
Surface hardening depth

$$SHD \cong 10^{-5} \cdot \frac{\left(4,4 \cdot \frac{p_H^2}{R_{p0,2}} - 3,5 \cdot p_H\right)}{\left(\frac{1}{r_L} + \frac{2}{D}\right)}$$

Legend

p_H	N/mm ²	Max. Hertzian pressure
CHD	mm	Case hardening depth
SHD	mm	Surface hardening depth
D	mm	Outside diameter of track roller
$R_{p0,2}$	N/mm ²	Proof stress of mating track material ►1408 t16
r_L	mm	Radius of mating track – the raceway must be flat in the direction of the yoke type track roller axis ►1405 q34.



q36
Case hardening depth CHD, hardness curve

CHD = case hardening depth with hardness 550 HV

HV = hardness

z = distance from surface

- ① Required hardness
- ② Case hardening

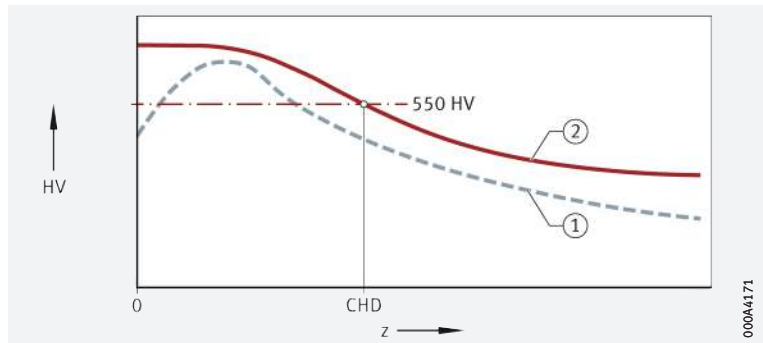

q37
Surface hardening depth SHD, hardness curve

SHD = surface hardening depth

HV = hardness

z = distance from surface

- ① Required hardness
- ② Flame or induction hardening

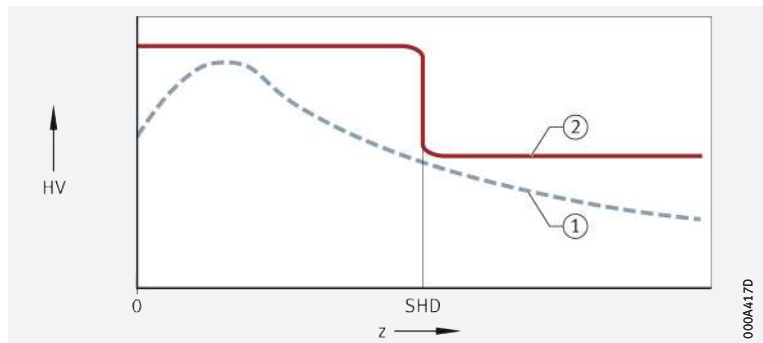

🔗 Ready-to-fit units

Schaeffler guideways as mating tracks

The Schaeffler guideways are ready-to-fit units from the Schaeffler linear range. They are to the appropriate grade Q20 for yoke and stud type track rollers and correspond to the dimensions of standard profiles:

- parallelism 20 $\mu\text{m}/\text{m}$
- surface quality Ramax 0,8
- hardness 58 HRC to 62 HRC
- angular misalignment between the raceways max. 1 mrad (1 $\mu\text{m}/\text{m}$)
- deviations of the guideway cross-section +0,05/+0,015
- length tolerance of the individual guideway +1/0 mm/m.

🔗 Address

Enquiry and delivery address

Schaeffler Technologies AG & Co. KG

Linear Technology Division

66406 Homburg (Saar)

Internet ➤ www.schaeffler.de/en

E-mail ➤ info.linear@schaeffler.com

Telephone 0180 5003872

Fax 0180 5003873

Protection of mating track



The mating track must be protected against contamination. Where necessary, covers and wipers, for instance made from felt, should be placed ahead of the track roller ➤ 1410 | 38.

🔗 38 Protection of mating track against contamination

① Covers

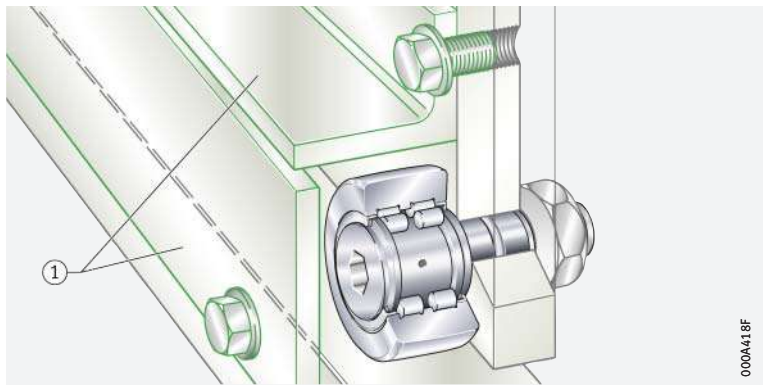

000A418F

1.17

Mounting and dismounting

 *Mounting*

Track rollers must be handled with care before and during assembly. Their trouble-free operation depends largely on the care taken during mounting.

 *Guidelines for mounting*

The products must be protected against dust, contaminants and moisture. Contaminants have a detrimental influence on the running and operating life of rolling bearings.

Do not cool the bearings excessively. Moisture due to condensation can lead to corrosion in the bearings and bearing seats.

Yoke type track rollers RSTO and STO are not self-retaining. The outer ring and the needle roller and cage assembly are matched to each other and must not be interchanged during mounting with components from other bearings of the same size.

The assembly area must be kept clean and free from dust.

Check the seat of the axis for dimensional, geometrical and positional accuracy and for cleanliness.

The seating surfaces of the bearing rings must be lightly oiled or rubbed with solid lubricant.

After mounting, the bearings must be supplied with lubricant.

Finally, the correct functioning of the bearing arrangement must be checked.

 *Mounting tools*

Depending on the application, the following are suitable:

- induction heaters; note the manufacturer's guidance on grease and seals
- heating cupboard; heating up to +80 °C
- mechanical or hydraulic presses; use mounting sleeves that cover the whole circumference of the bearing ring end faces
- hammer and mounting sleeves; blows should only be applied concentrically to the sleeve.



Mounting forces must never be directed through the rolling elements. Avoid direct blows on the bearing rings in all cases. Ensure that the seals are not damaged.

 *Guidelines for dismounting*

Dismounting should be taken into consideration in the original design of the bearing position. If the bearing is to be reused:

- avoid direct blows on the bearing rings
- dismounting forces should not be applied through the rolling elements
- carefully clean the bearings after dismounting
- do not use a concentrated or "hard" flame.

Mounting and dismounting of yoke type track rollers *Use a mounting press*

If the tolerances are unfavourable, the yoke type track roller should be pressed onto the shaft or stud using a mounting press ► 1412 |  39. The inner ring must be mounted such that the pressing-in force is distributed uniformly over the end face of the inner ring.

 *Lubrication hole*

The bearings must be mounted such that the lubrication hole is positioned in the unloaded zone. For yoke type track rollers PWTR and NNTR, defined positioning of the lubrication hole is not required.

39

Mounting of yoke type track roller using a mounting press

NUTR

① Mounting press

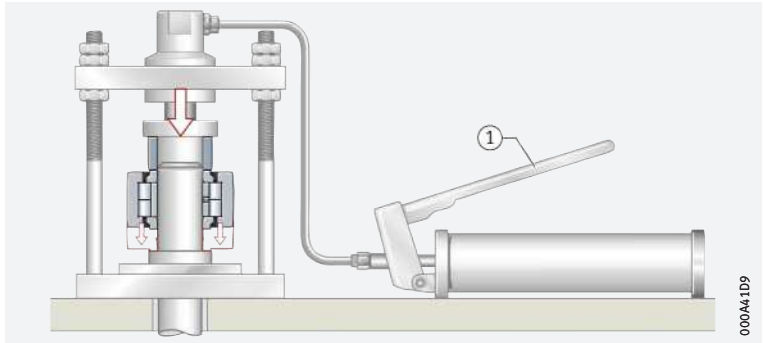

Axial location

Yoke type track rollers NUTR, PWTR and NNTR must be axially clamped in place ▶ 1412 | ④ 40.

40

Axial location

PWTR..-2RS

① Hexagon nut

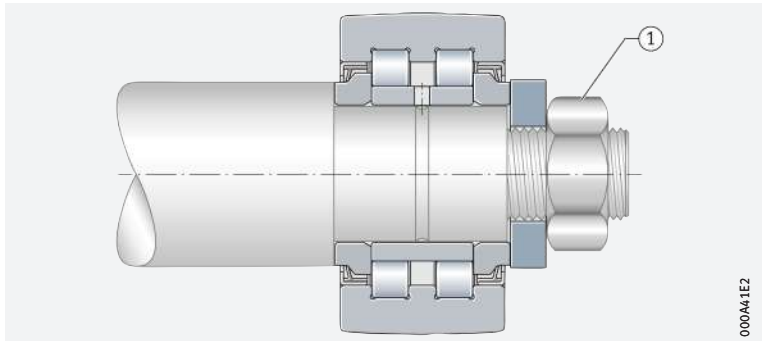

Mounting and dismounting of stud type track rollers

Use a mounting press

Stud type track rollers should be mounted using a mounting press if possible ▶ 1412 | ④ 39.



Blows on the flange of the roller stud must be avoided. The position of the lubrication hole is indicated on the flanged side of the roller stud. It must not be positioned in the loaded zone ▶ 1404 | ④ 33.

Fit the lubrication nipples before mounting the bearings

Drive fit lubrication nipples for stud type track rollers

Stud type track rollers are supplied with loose drive fit lubrication nipples that must be pressed in correctly before mounting of the bearings ▶ 1412 | ④ 41. For lubrication of stud type track rollers using the central lubrication adapter ▶ 1393 | ④ 24.



Only the lubrication nipples supplied may be used ▶ 1413 | ④ 17. If lubrication is to be carried out via the locating bore, the axial lubrication holes in the stud type track roller must be closed off using the lubrication nipples before mounting ▶ 1412 | ④ 41.

41

Stud type track roller with drive fit lubrication nipple and dimensions for pressing mandrel

KR..-PP

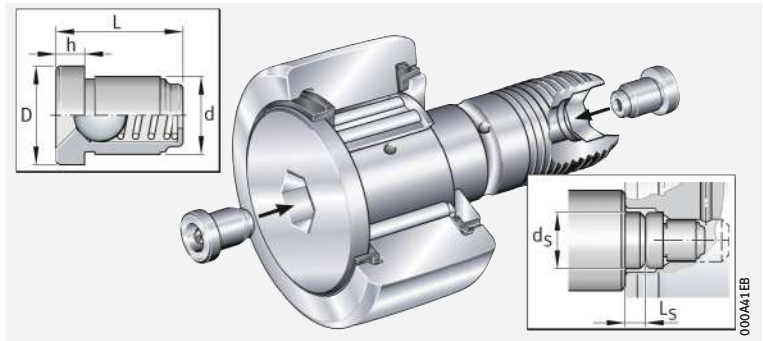

17

Drive fit lubrication nipples

Lubrication nipple	Dimensions						Suitable for outside diameter
	D	d	L	h	d _S ±0,1	L _S	
	mm	mm	mm	mm	mm	mm	D
NIPA1	6	4	6	1,5 ¹⁾	–	–	16 and 19
NIPA1×4,5	4,7	4	4,5	1	4,5	5	22 to 32
NIPA2×7,5	7,5	6	7,5	2	7,5	6	35 to 52
NIPA3×9,5	9,5	8	9,5	3	10	9	62 to 90

1) Projection of lubrication nipple, see product tables

Axial location of stud type track rollers

Secure bearings axially

Stud type track rollers must be axially secured using a hexagon nut. The slot or hexagonal socket on the end of the roller stud can be used to hold the bearing by means of a key while tightening the fixing nut and to adjust the eccentric collar ▶ 1413 | 42. If heavy vibration occurs, self-locking nuts to DIN 985 or special locking washers can be used.



The tightening torque for the fixing nuts stated in the product tables must be observed. It is only in this way that the permissible radial load can be ensured. If this cannot be adhered to, an interference fit is required. For self-locking nuts, a higher tightening torque must be observed; the advice given by the nut manufacturer must be followed.

42
Securing the bearing using an Allen key

① Allen key

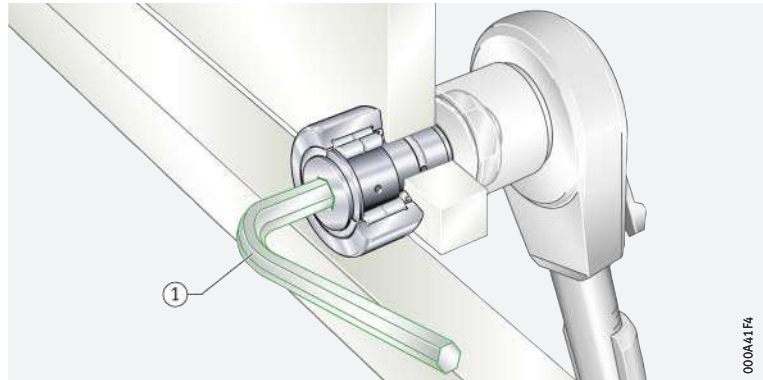

Stud type track rollers with eccentric collar

Highest point on the eccentric collar

The highest point on the eccentric collar is indicated on the roller stud side, which also gives the position of the radial lubrication hole.

Commissioning and relubrication

Position of the relubrication holes

Stud type track rollers have a lubrication hole for relubrication:

- on the flange side of the roller stud
- on the thread-side end face for outside diameters from 22 mm
- on the shank of the roller stud, for outside diameters from 30 mm with an additional lubrication groove.



Stud type track rollers with an eccentric collar cannot be relubricated via the stud. The eccentric collar covers the lubrication hole.

For lubrication, only grease guns with needle-point nozzles may be used that have an opening angle ≤ 60° ▶ 1414 | 43.

Before commissioning, the lubrication holes and feed pipes must be filled with grease in order to ensure protection against corrosion; lubrication can be carried out at the same time.

Lubrication will be more difficult if a rolling element is located over the radial lubrication hole. Relubrication should therefore be carried out with the bearing still warm from operation and rotating if safe to do so, before the bearing comes to rest if safe to do so and before extended breaks in operation.

The grease used for relubrication should be the same as that used for initial greasing. If this is not possible, the miscibility and compatibility of the greases must be checked. Relubrication should continue until a fresh collar of grease appears at the seal gaps. The old grease must be able to leave the bearing unhindered.

43

Relubrication using a grease gun

- ① Needle-point nozzle, opening angle $\leq 60^\circ$

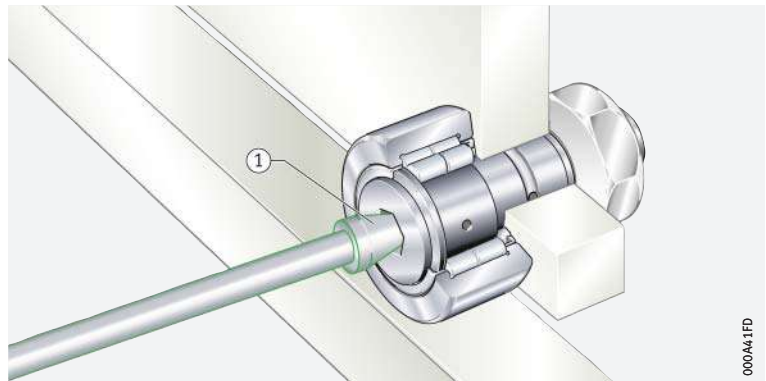

000441FD

Schaeffler Mounting Handbook

Rolling bearings must be handled with great care

Rolling bearings are well-proven precision machine elements for the design of economical and reliable bearing arrangements, which offer high operational security. In order that these products can function correctly and achieve the envisaged operating life without detrimental effect, they must be handled with care.



The Schaeffler Mounting Handbook MH 1 gives comprehensive information about the correct storage, mounting, dismounting and maintenance of rotary rolling bearings ► <https://www.schaeffler.de/std/1D53>. It also provides information which should be observed by the designer, in relation to the mounting, dismounting and maintenance of bearings, in the original design of the bearing position. This book is available from Schaeffler on request.

1.18

Legal notice regarding data freshness

The further development of products may also result in technical changes to catalogue products

Of central interest to Schaeffler is the further development and optimisation of its products and the satisfaction of its customers. In order that you, as the customer, can keep yourself optimally informed about the progress that is being made here and with regard to the current technical status of the products, we publish any product changes which differ from the printed version in our electronic product catalogue.



We therefore reserve the right to make changes to the data and illustrations in this catalogue. This catalogue reflects the status at the time of printing. More recent publications released by us (as printed or digital media) will automatically precede this catalogue if they involve the same subject. Therefore, please always use our electronic product catalogue to check whether more up-to-date information or modification notices exist for your desired product.

Link to electronic product catalogue



The following link will take you to the Schaeffler electronic product catalogue: ► <https://medias.schaeffler.com>.

1.19 Further information

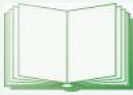

In addition to the data in this chapter, the following chapters in Technical principles must also be observed in the design of bearing arrangements:

- Determining the bearing size ► 34
- Rigidity ► 54
- Friction and increases in temperature ► 56
- Speeds ► 64
- Bearing data ► 97
- Lubrication ► 70
- Sealing ► 182
- Design of bearing arrangements ► 139
- Mounting and dismounting ► 191.





Yoke type roller bearing track rollers

Without axial guidance
Open

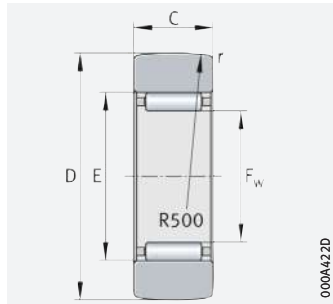

RSTO

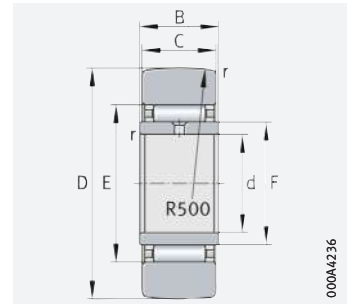

STO

D = 16 – 90 mm

Main dimensions			Basic load ratings		Fatigue limit load C_{urw} N	Speed n_{DG} min^{-1}	Mass m ≈ g	Without inner ring Designation ▶ 1398 1.12 ▶ 1399 1.13	Dimensions	
D	F _{Fw} ¹⁾	C	dyn. C_{rw} N	stat. C_{0rw} N					E	r
16	7	7,8	2 550	2 600	330	16 000	8,5	RSTO5-TV	10	0,3
19	10	9,8	3 750	4 550	650	10 000	12,5	RSTO6-TV	13	0,3
24	12	9,8	4 200	5 500	780	8 000	21	RSTO8-TV	15	0,3
30	14	11,8	8 400	9 300	1 370	5 500	42	RSTO10	20	0,3
32	16	11,8	9 000	10 300	1 530	4 500	49	RSTO12	22	0,3
35	20	11,8	9 100	10 900	1 640	3 300	50	RSTO15	26	0,3
40	22	15,8	14 200	17 900	2 550	2 800	88	RSTO17	29	0,3
47	25	15,8	16 100	21 700	3 050	2 400	130	RSTO20	32	0,3
52	30	15,8	16 400	23 200	3 300	1 800	150	RSTO25	37	0,3
62	38	19,8	23 100	35 000	4 700	1 300	255	RSTO30	46	0,6
72	42	19,8	25 000	40 500	5 400	1 100	375	RSTO35	50	0,6
80	50	19,8	23 700	39 500	5 900	850	420	RSTO40	58	1
85	55	19,8	25 000	43 500	5 900	750	453	RSTO45	63	1
90	60	19,8	25 500	46 000	6 300	650	481	RSTO50	68	1

Main dimensions			Basic load ratings		Fatigue limit load C_{urw} N	Speed n_{DG} min^{-1}	Mass m ≈ g	With inner ring Designation ▶ 1398 1.12 ▶ 1399 1.13	Dimensions			
D	F ¹⁾	C	dyn. C_{rw} N	stat. C_{0rw} N					d	B	E	r
19	10	9,8	3 750	4 550	650	10 000	17	STO6-TV	6	10	13	0,3
24	12	9,8	4 200	5 500	780	8 000	26	STO8-TV	8	10	15	0,3
30	14	11,8	8 400	9 300	1 370	5 500	49	STO10	10	12	20	0,3
32	16	11,8	9 000	10 300	1 530	4 500	57	STO12	12	12	22	0,3
35	20	11,8	9 100	10 900	1 640	3 300	63	STO15	15	12	26	0,3
40	22	15,8	14 200	17 900	2 550	2 800	107	STO17	17	16	29	0,3
47	25	15,8	16 100	21 700	3 050	2 400	152	STO20	20	16	32	0,3
52	30	15,8	16 400	23 200	3 300	1 800	177	STO25	25	16	37	0,3
62	38	19,8	23 100	35 000	4 700	1 300	308	STO30	30	20	46	0,6
72	42	19,8	25 000	40 500	5 400	1 100	441	STO35	35	20	50	0,6
80	50	19,8	23 700	39 500	5 900	850	530	STO40	40	20	58	1
85	55	19,8	25 000	43 500	5 900	750	576	STO45	45	20	63	1
90	60	19,8	25 500	46 000	6 300	650	617	STO50	50	20	68	1

medias ▶ <https://www.schaeffler.de/std/1E1D>

¹⁾ F = raceway diameter of inner ring; F_w = needle roller enveloping circle in tolerance class F6.



Yoke type roller bearing track rollers

Without axial guidance
Sealed

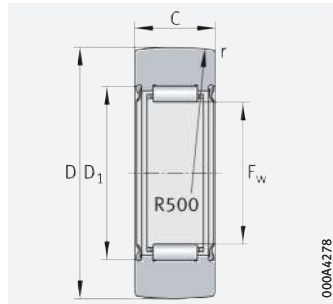

RNA22
With seal 2RSR

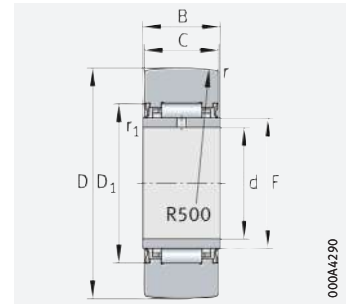

NA22
With seal 2RSR

D = 19 – 90 mm

Main dimensions			Basic load ratings		Fatigue limit load C_{urw} N	Speed n_{DG} min^{-1}	Mass m \approx g	Without inner ring Designation ► 1398 1.12 ► 1399 1.13	Dimensions	
D	F $F_w^{1)}$	C	dyn. C_{rw} N	stat. C_{0rw} N					D_1	r
19	10	11,8	3 900	3 700	485	9 000	18	RNA22/6-2RSR	15,15	0,3
24	12	11,8	4 800	4 300	630	7 000	29	RNA22/8-2RSR	18	0,3
30	14	13,8	7 000	6 900	1 090	5 500	52	RNA2200-2RSR	20	0,6
32	16	13,8	7 500	8 300	1 270	4 700	57	RNA2201-2RSR	22	0,6
35	20	13,8	7 600	9 800	1 370	3 400	60	RNA2202-2RSR	26	0,6
40	22	15,8	9 900	14 000	1 840	3 000	94	RNA2203-2RSR	28	1
47	25	17,8	14 000	19 100	2 650	2 300	152	RNA2204-2RSR	33	1
52	30	17,8	14 400	20 800	2 900	1 800	179	RNA2205-2RSR	38	1
62	35	19,8	17 100	26 000	3 550	1 400	284	RNA2206-2RSR	43	1
72	42	22,7	21 500	36 000	5 200	1 100	432	RNA2207-2RSR	50	1,1
80	48	22,7	26 000	41 000	5 300	850	530	RNA2208-2RSR	57	1,1



Main dimensions			Basic load ratings		Fatigue limit load C_{urw} N	Speed n_{DG} min^{-1}	Mass m \approx g	With inner ring Designation ► 1398 1.12 ► 1399 1.13	Dimensions				
D	F ¹⁾	C	dyn. C_{rw} N	stat. C_{0rw} N					d	B	D_1	r	r_1
19	10	11,8	3 900	3 700	485	9 000	22	NA22/6-2RSR	6	12	16	0,3	0,3
24	12	11,8	4 800	4 300	630	7 000	34	NA22/8-2RSR	8	12	18	0,3	0,3
30	14	13,8	7 000	6 900	1 090	5 500	60	NA2200-2RSR	10	14	20	0,6	0,3
32	16	13,8	7 500	8 300	1 270	4 700	67	NA2201-2RSR	12	14	22	0,6	0,3
35	20	13,8	7 600	9 800	1 370	3 400	75	NA2202-2RSR	15	14	26	0,6	0,3
40	22	15,8	9 900	14 000	1 840	3 000	112	NA2203-2RSR	17	16	28	1	0,3
47	25	17,8	14 000	19 100	2 650	2 300	177	NA2204-2RSR	20	18	33	1	0,3
52	30	17,8	14 400	20 800	2 900	1 800	209	NA2205-2RSR	25	18	38	1	0,3
62	35	19,8	17 100	26 000	3 550	1 400	324	NA2206-2RSR	30	20	43	1	0,3
72	42	22,7	21 500	36 000	5 200	1 100	505	NA2207-2RSR	35	23	50	1,1	0,6
80	48	22,7	26 000	41 000	5 300	850	628	NA2208-2RSR	40	23	57	1,1	0,6
90	58	22,7	26 000	43 000	5 600	650	690	NA2210-2RSR	50	23	68	1,1	0,6

medias ► <https://www.schaeffler.de/std/1E1E>

¹⁾ F = raceway diameter of inner ring; F_w = needle roller enveloping circle in tolerance class F6.



Yoke type roller bearing track rollers

With axial guidance
Gap seal or
axial plain washer

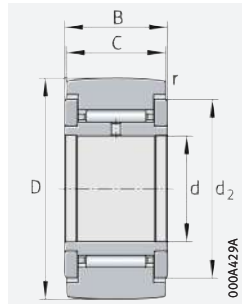

NATR (R = 500 mm)
With gap seal

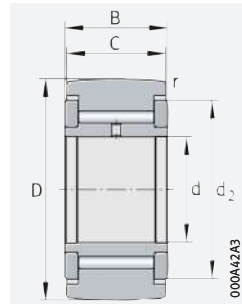

NATV (R = 500 mm)
With gap seal

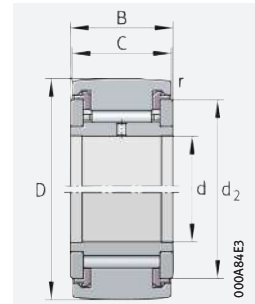

NATR, NATV
With optimised INA profile
With axial plain washer

D = 5 – 50 mm

Main dimensions			Basic load ratings		Fatigue limit load	Speed	Mass	Designation ¹⁾	Mass	Designation ²⁾	Dimensions		
d	D	B	dyn. C _{rw} N	stat. C _{0rw} N	C _{urw} N	n _{DG} min ⁻¹	m ≈ g	▶ 1398 1.12 ▶ 1399 1.13	m ≈ g	▶ 1398 1.12 ▶ 1399 1.13	C	d ₂	r
													min.
5	16	12	3 150	3 350	450	14 000	14	NATR5	14	NATR5-PP	11	12,5	0,15
	16	12	4 900	6 600	950	3 800	15	NATV5	15	NATV5-PP	11	12,5	0,15
6	19	12	3 500	4 000	540	11 000	20	NATR6	19	NATR6-PP	11	15	0,15
	19	12	5 400	8 000	1 170	3 100	21	NATV6	21	NATV6-PP	11	15	0,15
8	24	15	5 500	6 600	930	7 500	41	NATR8	38	NATR8-PP	14	19	0,3
	24	15	7 800	11 600	1 590	2 500	42	NATV8	41	NATV8-PP	14	19	0,3
10	30	15	6 800	8 600	1 220	5 500	64	NATR10	64	NATR10-PP	14	23	0,6
	30	15	9 500	14 900	2 050	2 100	65	NATV10	64	NATV10-PP	14	23	0,6
12	32	15	7 000	9 000	1 290	4 500	71	NATR12	66	NATR12-PP	14	25	0,6
	32	15	9 700	15 700	2 170	1 800	72	NATV12	69	NATV12-PP	14	25	0,6
15	35	19	9 700	14 300	1 830	3 600	101	NATR15	95	NATR15-PP	18	27,6	0,6
	35	19	12 600	23 100	3 200	1 600	109	NATV15	101	NATV15-PP	18	27,6	0,6
17	40	21	10 900	15 800	2 090	2 900	144	NATR17	139	NATR17-PP	20	31,5	1
	40	21	14 700	26 500	3 500	1 400	152	NATV17	147	NATV17-PP	20	31,5	1
20	47	25	15 400	26 000	3 400	2 400	246	NATR20	236	NATR20-PP	24	36,5	1
	47	25	20 300	42 000	5 900	1 300	254	NATV20	245	NATV20-PP	24	36,5	1
25	52	25	15 300	27 000	3 550	1 800	275	NATR25	271	NATR25-PP	24	41,5	1
	52	25	20 200	44 000	6 200	1 000	285	NATV25	281	NATV25-PP	24	41,5	1
30	62	29	23 200	39 000	5 200	1 300	470	NATR30	444	NATR30-PP	28	51	1
	62	29	30 000	62 000	8 800	850	481	NATV30	468	NATV30-PP	28	51	1
35	72	29	24 800	44 500	5 900	1 000	–	–	547	NATR35-PP	28	58	1,1
	72	29	32 500	71 000	10 100	750	–	–	630	NATV35-PP	28	58	1,1
40	80	32	32 000	58 000	8 300	850	–	–	795	NATR40-PP	30	66	1,1
	80	32	40 000	88 000	13 000	650	–	–	832	NATV40-PP	30	66	1,1
50	90	32	31 000	59 000	8 400	650	–	–	867	NATR50-PP	30	76	1,1
	90	32	39 000	92 000	13 600	550	–	–	969	NATV50-PP	30	76	1,1

medias ▶ <https://www.schaeffler.de/std/1E1F>

- 1) Bearings with gap seals and radius of curvature of R = 500 mm.
- 2) Bearings with plastic axial plain washer and optimised INA profile.
Permissible operating temperature: –30 °C to +100 °C (continuous operation).



Yoke type roller bearing track rollers

With axial guidance

Sealed

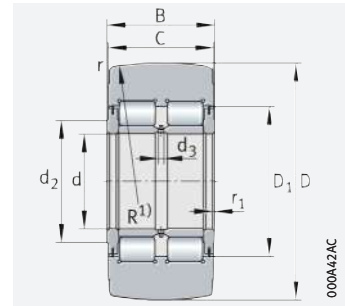

NNTR
With seal 2ZL

D = 130 – 310 mm

Main dimensions			Basic load ratings				Fatigue limit load	Speed	Mass	Designation ¹⁾
D	d	B	dyn. C_{rw}	stat. C_{0rw}	dyn. $F_{r\ per}$	stat. $F_{0r\ per}$	C_{urw}	n_{DG}	m	
h10			N	N	N	N	N	min^{-1}	≈ kg	
130	50	65	193 000	265 000	265 000	265 000	37 000	1 100	5 200	NNTR50×130×65-2ZL
140	55	70	226 000	315 000	280 000	315 000	44 500	850	6 400	NNTR55×140×70-2ZL
150	60	75	255 000	365 000	330 000	365 000	53 000	800	7 800	NNTR60×150×75-2ZL
160	65	75	280 000	395 000	350 000	395 000	56 000	700	8 800	NNTR65×160×75-2ZL
180	70	85	355 000	510 000	465 000	510 000	75 000	600	13 000	NNTR70×180×85-2ZL
200	80	90	415 000	610 000	550 000	610 000	87 000	500	16 800	NNTR80×200×90-2ZL
220	90	100	500 000	750 000	600 000	750 000	104 000	400	22 500	NNTR90×220×100-2ZL
240	100	105	560 000	870 000	710 000	870 000	118 000	340	28 000	NNTR100×240×105-2ZL
260	110	115	670 000	1 050 000	820 000	1 050 000	143 000	300	35 600	NNTR110×260×115-2ZL
290	120	135	880 000	1 400 000	1 110 000	1 400 000	187 000	260	52 800	NNTR120×290×135-2ZL
310	130	146	1 010 000	1 630 000	1 280 000	1 630 000	216 000	240	65 200	NNTR130×310×146-2ZL



Dimensions				Mounting dimensions			Number of lubrication holes	Designation ¹⁾
D	C	r	r_1	d_2	D_1	d_3		
h10		min.	min.					
130	63	3	2	63	80	3	3	NNTR50×130×65-2ZL
140	68	3	2	73	91	4	3	NNTR55×140×70-2ZL
150	73	3	2	78	97	4	3	NNTR60×150×75-2ZL
160	73	3	2	82	103	5	3	NNTR65×160×75-2ZL
180	83	3	2	92	115	5	3	NNTR70×180×85-2ZL
200	88	4	2	102	127	5	3	NNTR80×200×90-2ZL
220	98	4	2,5	119	146	5	3	NNTR90×220×100-2ZL
240	103	4	2,5	132	160	6	6	NNTR100×240×105-2ZL
260	113	4	2,5	143	174	6	6	NNTR110×260×115-2ZL
290	133	4	3	155	191	8	6	NNTR120×290×135-2ZL
310	144	5	3	165	204	8	6	NNTR130×310×146-2ZL

medias ► <https://www.schaeffler.de/std/1E20>

¹⁾ Radius of curvature R = 10 000 for NNTR50×130×65-2ZL to NNTR110×260×115-2ZL.

Radius of curvature R = 15 000 for NNTR120×290×135-2ZL to NNTR130×310×146-2ZL.



Yoke type roller bearing track rollers

With optimised INA profile and axial guidance
Sealed

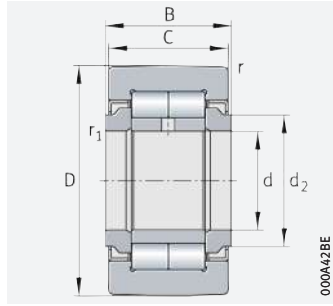

NUTR
With optimised INA profile and labyrinth seal

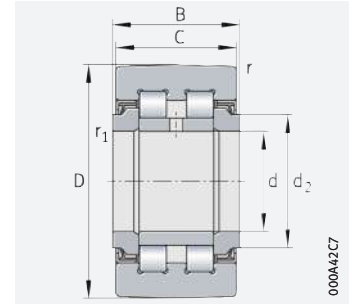

PWTR
With optimised INA profile and seal 2RS

D = 35 – 110 mm

Main dimensions			Basic load ratings				Fatigue limit load	Speed	Mass	Designation	Dimensions			
D	d	B	dyn. C _{rw}	stat. C _{0rw}	dyn. F _{r per}	stat. F _{0r per}	C _{urw}	n _{DG}	m		C	d ₂	r	r ₁
			N	N	N	N	N	min ⁻¹	≈ g	▶ 1398 1.12 ▶ 1399 1.13 X-life ▶ 1384	min.			min.
35	15	19	15 300	18 700	8 500	16 800	2 430	6 500	99	NUTR15	18	20	0,6	0,3
	15	19	12 600	14 600	10 700	14 600	1 760	6 000	99	PWTR15-2RS-XL	18	20	0,6	0,3
40	17	21	18 700	24 900	13 000	24 900	3 150	5 500	147	NUTR17	20	22	1	0,5
	17	21	14 300	17 900	16 500	17 900	2 160	5 000	147	PWTR17-2RS-XL	20	22	1	0,5
42	15	19	18 300	24 300	24 300	24 300	3 100	6 500	158	NUTR1542	18	20	0,6	0,3
	15	19	14 700	16 200	16 200	16 200	2 140	6 000	158	PWTR1542-2RS-XL	18	20	0,6	0,3
47	17	21	21 600	30 500	30 500	30 500	3 850	5 500	220	NUTR1747	20	22	1	0,5
	17	21	15 900	18 400	18 400	18 400	2 440	5 000	220	PWTR1747-2RS-XL	20	22	1	0,5
	20	25	28 500	37 500	16 200	32 500	4 850	4 200	245	NUTR20	24	27	1	0,5
	20	25	24 500	30 500	20 700	30 500	3 750	3 800	245	PWTR20-2RS-XL	24	27	1	0,5
52	20	25	32 000	44 000	38 000	44 000	5 700	4 200	321	NUTR2052	24	27	1	0,5
	20	25	27 000	35 000	31 000	35 000	4 250	3 800	321	PWTR2052-2RS-XL	24	27	1	0,5
	25	25	29 000	40 500	17 100	34 000	5 300	4 200	281	NUTR25	24	31	1	0,5
	25	25	25 000	33 000	21 800	33 000	4 100	3 800	281	PWTR25-2RS-XL	24	31	1	0,5
62	25	25	35 500	54 000	54 000	54 000	6 900	4 200	450	NUTR2562	24	31	1	0,5
	25	25	30 000	42 500	42 500	42 500	5 200	3 800	450	PWTR2562-2RS-XL	24	31	1	0,5
	30	29	40 000	55 000	23 400	46 000	7 300	2 600	465	NUTR30	28	38	1	0,5
	30	29	35 000	45 500	29 000	45 500	5 800	2 200	465	PWTR30-2RS-XL	28	38	1	0,5

medias ▶ <https://www.schaeffler.de/std/1E21>



Main dimensions			Basic load ratings				Fatigue limit load	Speed	Mass	Designation ▶ 1398 1.12 ▶ 1399 1.13 X-life ▶ 1384	Dimensions			
D	d	B	dyn. C _{rW}	stat. C _{0rW}	dyn. F _{r per}	stat. F _{0r per}	C _{urw}	n _{DG}	m		C	d ₂	r	r ₁
			N	N	N	N	N	min ⁻¹	≈ g				min.	min.
72	30	29	48 000	70 000	68 000	70 000	9 200	2 600	697	NUTR3072	28	38	1	0,5
	30	29	41 000	56 000	54 000	56 000	7 200	2 200	697	PWTR3072-2RS-XL	28	38	1	0,5
	35	29	45 000	65 000	31 500	63 000	8 700	2 100	630	NUTR35	28	44	1,1	0,6
	35	29	38 500	54 000	39 000	54 000	6 900	1 800	630	PWTR35-2RS-XL	28	44	1,1	0,6
80	35	29	51 000	78 000	76 000	78 000	10 300	2 100	836	NUTR3580	28	44	1,1	0,6
	35	29	43 500	63 000	59 000	63 000	8 100	1 800	836	PWTR3580-2RS-XL	28	44	1,1	0,6
	40	32	56 000	80 000	31 000	60 000	11 000	1 600	816	NUTR40	30	50,5	1,1	0,6
	40	32	45 000	61 000	39 500	61 000	7 900	1 500	816	PWTR40-2RS-XL	30	50,5	1,1	0,6
85	45	32	56 000	83 000	32 000	62 000	11 500	1 400	883	NUTR45	30	55,2	1,1	0,6
	45	32	45 500	63 000	41 000	63 000	8 200	1 300	883	PWTR45-2RS-XL	30	55,2	1,1	0,6
90	40	32	66 000	101 000	84 000	101 000	13 900	1 600	1 129	NUTR4090	30	50,5	1,1	0,6
	40	32	52 000	75 000	67 000	75 000	9 600	1 500	1 129	PWTR4090-2RS-XL	30	50,5	1,1	0,6
	50	32	56 000	86 000	32 500	63 000	11 900	1 300	950	NUTR50	30	59,8	1,1	0,6
	50	32	46 000	66 000	42 000	66 000	8 500	1 100	950	PWTR50-2RS-XL	30	59,8	1,1	0,6
100	45	32	72 000	115 000	106 000	115 000	15 800	1 400	1 396	NUTR45100	30	55,2	1,1	0,6
	45	32	56 000	85 000	85 000	85 000	10 900	1 300	1 396	PWTR45100-2RS-XL	30	55,2	1,1	0,6
110	50	32	76 000	128 000	128 000	128 000	17 600	1 300	1 690	NUTR50110	30	59,8	1,1	0,6
	50	32	59 000	94 000	94 000	94 000	12 100	1 100	1 690	PWTR50110-2RS-XL	30	59,8	1,1	0,6

medias ▶ <https://www.schaeffler.de/std/1E22>





Stud type needle roller bearing track rollers

With axial guidance
Open or sealed

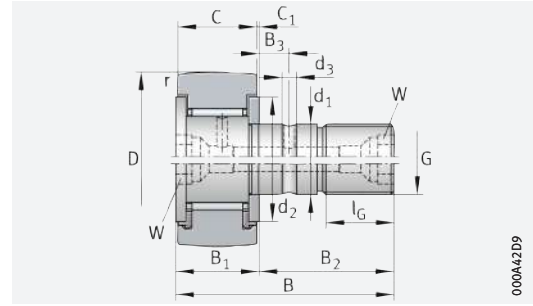

$D \geq 22$ mm: KR (top: $R = 500$ mm);
KR..-PP (bottom: with optimised INA profile)

000A42D9

D = 16 – 32 mm

Main dimensions			Basic load ratings		Fatigue limit load	Speed	Mass	Designation	Mass	With eccentric collar Designation
D	d ₁	B	dyn. C _{r_w} N	stat. C _{0r_w} N	C _{ur_w} N	n _{DG} min ⁻¹	m ≈ g	➤ 1398 1.12 ➤ 1399 1.13	m ≈ g	➤ 1398 1.12 ➤ 1399 1.13
16	6	28	3 150	3 350	450	14 000	19	KR16 ³⁾	–	–
	6	28	3 150	3 350	450	14 000	18	KR16-PP ³⁾	20	KRE16-PP ³⁾
	6	28	3 150	3 350	450	14 000	19	KR16-SK-PP ⁴⁾	–	–
	6	28	4 900	6 600	950	3 800	19	KRV16-PP ³⁾	–	–
19	8	32	3 500	4 000	540	11 000	29	KR19 ³⁾	–	–
	8	32	3 500	4 000	540	11 000	29	KR19-PP ³⁾	32	KRE19-PP ³⁾
	8	32	3 500	4 000	540	11 000	29	KR19-SK-PP ⁴⁾	–	–
	8	32	5 400	8 000	1 170	3 100	31	KRV19-PP ³⁾	–	–
22	10	36	4 550	5 300	730	8 000	45	KR22	–	–
	10	36	4 550	5 300	730	8 000	43	KR22-PP	47	KRE22-PP
	10	36	6 200	9 200	1 210	2 600	45	KRV22-PP	–	–
26	10	36	5 100	6 400	840	8 000	59	KR26	–	–
	10	36	5 100	6 400	840	8 000	57	KR26-PP	62	KRE26-PP
	10	36	7 300	11 500	1 500	2 600	59	KRV26-PP	–	–
30	12	40	6 800	8 600	1 220	5 500	92	KR30	–	–
	12	40	6 800	8 600	1 220	5 500	88	KR30-PP	93	KRE30-PP
	12	40	9 500	14 900	2 050	2 100	91	KRV30-PP	–	–
32	12	40	7 100	9 200	1 290	5 500	103	KR32	–	–
	12	40	7 100	9 200	1 290	5 500	98	KR32-PP	104	KRE32-PP
	12	40	10 000	16 100	2 200	2 100	101	KRV32-PP	–	–

medias ➤ <https://www.schaeffler.de/std/1E23>

- 1) Drive fit lubrication nipples are supplied loose. Only these lubrication nipples should be used.
- 2) Nominal dimension for hexagonal socket.
- 3) Relubrication hole only on the flange-side end face with slot for countertensioning during fitting.
- 4) Hexagonal socket only on the flange-side end face. No relubrication facility.

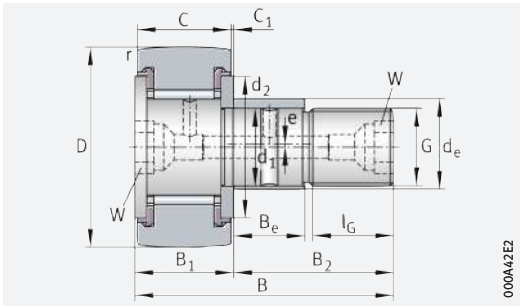

D ≥ 22 mm: KRE...-PP, with optimised INA profile

000A42E2

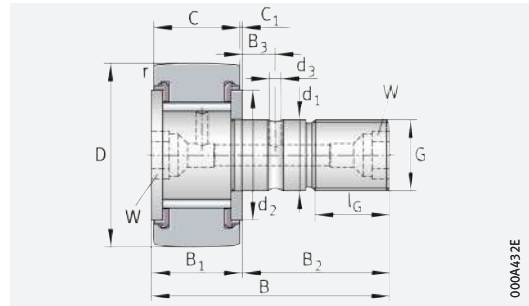

D ≥ 22 mm: KRV...-PP, with optimised INA profile

000A432E

Dimensions

D	B ₁	B ₂	B ₃	C	C ₁	r	d ₂	d ₃	G	l _G	W ²⁾	Eccentric collar			Drive fit lubrication nipple ¹⁾	Nut tightening torque M _A
												d _e	B _e	e		
	max.					min.						h9			Nm	
16	12,2	16	–	11	0,6	0,15	12,5	–	M6	8	–	–	–	–	NIPA1	3
	12,2	16	–	11	0,6	0,15	12,5	–	M6	8	–	9	7	0,5	NIPA1	3
	12,2	16	–	11	0,6	0,15	12,5	–	M6	8	4	–	–	–	–	3
	12,2	16	–	11	0,6	0,15	12,5	–	M6	8	–	–	–	–	NIPA1	3
19	12,2	20	–	11	0,6	0,15	15	–	M8	10	–	–	–	–	NIPA1	8
	12,2	20	–	11	0,6	0,15	15	–	M8	10	–	11	9	0,5	NIPA1	8
	12,2	20	–	11	0,6	0,15	15	–	M8	10	4	–	–	–	–	8
	12,2	20	–	11	0,6	0,15	15	–	M8	10	–	–	–	–	NIPA1	8
22	13,2	23	–	12	0,6	0,3	17,5	–	M10×1	12	5	–	–	–	NIPA1×4,5	15
	13,2	23	–	12	0,6	0,3	17,5	–	M10×1	12	5	13	10	0,5	NIPA1×4,5	15
	13,2	23	–	12	0,6	0,3	17,5	–	M10×1	12	5	–	–	–	NIPA1×4,5	15
26	13,2	23	–	12	0,6	0,3	17,5	–	M10×1	12	5	–	–	–	NIPA1×4,5	15
	13,2	23	–	12	0,6	0,3	17,5	–	M10×1	12	5	13	10	0,5	NIPA1×4,5	15
	13,2	23	–	12	0,6	0,3	17,5	–	M10×1	12	5	–	–	–	NIPA1×4,5	15
30	15,2	25	6	14	0,6	0,6	23	3	M12×1,5	13	6	–	–	–	NIPA1×4,5	22
	15,2	25	6	14	0,6	0,6	23	3	M12×1,5	13	6	15	11	0,5	NIPA1×4,5	22
	15,2	25	6	14	0,6	0,6	23	3	M12×1,5	13	6	–	–	–	NIPA1×4,5	22
32	15,2	25	6	14	0,6	0,6	23	3	M12×1,5	13	6	–	–	–	NIPA1×4,5	22
	15,2	25	6	14	0,6	0,6	23	3	M12×1,5	13	6	15	11	0,5	NIPA1×4,5	22
	15,2	25	6	14	0,6	0,6	23	3	M12×1,5	13	6	–	–	–	NIPA1×4,5	22

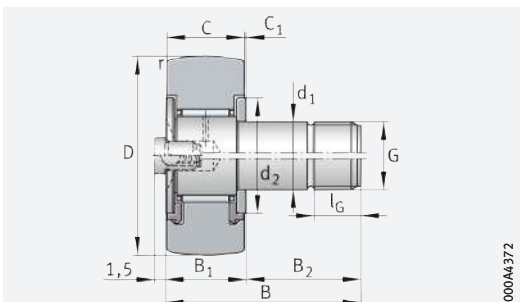

KR16, KR19 (top)
KR16-PP, KR19-PP (KRV16-PP, KRV19-PP) (bottom)

000A4372

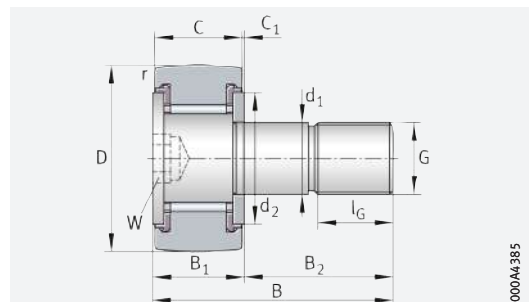

KR16-SK-PP, KR19-SK-PP

000A4385



Stud type needle roller bearing track rollers

With axial guidance
Open or sealed

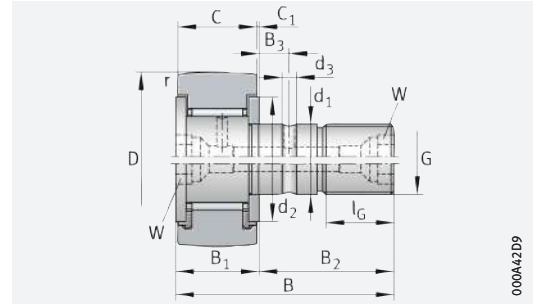

KR (top: R = 500 mm);
KR..-PP (bottom: with optimised INA profile)

D = 35 – 90 mm

Main dimensions			Basic load ratings		Fatigue limit load	Speed	Mass	Designation	Mass	With eccentric collar Designation
D	d ₁	B	dyn. C _{rW} N	stat. C _{0rW} N						
35	16	52	9 700	14 300	1 830	3 600	173	KR35	–	–
	16	52	9 700	14 300	1 830	3 600	164	KR35-PP	177	KRE35-PP
	16	52	12 600	23 100	3 200	1 600	166	KRV35-PP	–	–
40	18	58	10 900	15 800	2 090	2 900	247	KR40	–	–
	18	58	10 900	15 800	2 090	2 900	239	KR40-PP	255	KRE40-PP
	18	58	14 700	26 500	3 500	1 400	247	KRV40-PP	–	–
47	20	66	15 400	26 000	3 400	2 400	381	KR47-PP	400	KRE47-PP
	20	66	20 300	42 000	5 900	1 300	390	KRV47-PP	–	–
52	20	66	16 600	29 000	3 800	2 400	454	KR52-PP	473	KRE52-PP
	20	66	22 300	48 000	6 700	1 300	463	KRV52-PP	–	–
62	24	80	26 000	48 000	6 800	1 900	770	KR62-PP	789	KRE62-PP
	24	80	33 500	75 000	11 200	1 100	787	KRV62-PP	–	–
72	24	80	28 000	53 000	7 200	1 900	1 010	KR72-PP	1 038	KRE72-PP
	24	80	36 500	85 000	12 600	1 100	1 027	KRV72-PP	–	–
80	30	100	38 500	77 000	11 000	1 300	1 608	KR80-PP	1 665	KRE80-PP
	30	100	48 500	117 000	17 400	850	1 636	KRV80-PP	–	–
90	30	100	40 500	83 000	11 700	1 300	1 975	KR90-PP	2 032	KRE90-PP
	30	100	52 000	129 000	19 000	850	2 003	KRV90-PP	–	–

medias ▶ <https://www.schaeffler.de/std/1E24>

- 1) Drive fit lubrication nipples are supplied loose. Only these lubrication nipples should be used.
- 2) Nominal dimension for hexagonal socket.
Suitable central lubrication adapter for connection to a central lubrication system ▶ 1393.

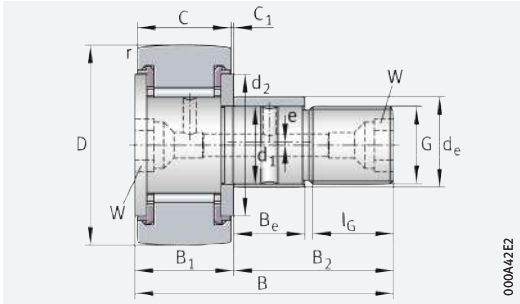

KRE..-PP, with optimised INA profile

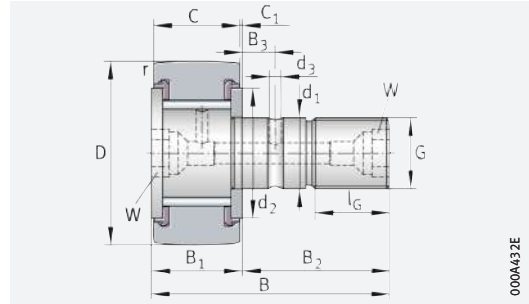

KRV..-PP, with optimised INA profile

Dimensions

D	B ₁	B ₂	B ₃	C	C ₁	r	d ₂	d ₃	G	l _G	W ²⁾	Eccentric collar			Drive fit lubrication nipple ¹⁾	Nut tightening torque M _A
												d _e	B _e	e		
												h9				
35	19,6	32,5	8	18	0,8	0,6	27,6	3	M16×1,5	17	8	-	-	-	NIPA2×7,5	58
	19,6	32,5	8	18	0,8	0,6	27,6	3	M16×1,5	17	8	20	14	1	NIPA2×7,5	58
	19,6	32,5	8	18	0,8	0,6	27,6	3	M16×1,5	17	8	-	-	-	NIPA2×7,5	58
40	21,6	36,5	8	20	0,8	1	31,5	3	M18×1,5	19	8	-	-	-	NIPA2×7,5	87
	21,6	36,5	8	20	0,8	1	31,5	3	M18×1,5	19	8	22	16	1	NIPA2×7,5	87
	21,6	36,5	8	20	0,8	1	31,5	3	M18×1,5	19	8	-	-	-	NIPA2×7,5	87
47	25,6	40,5	9	24	0,8	1	36,5	4	M20×1,5	21	10	24	18	1	NIPA2×7,5	120
	25,6	40,5	9	24	0,8	1	36,5	4	M20×1,5	21	10	-	-	-	NIPA2×7,5	120
52	25,6	40,5	9	24	0,8	1	36,5	4	M20×1,5	21	10	24	18	1	NIPA2×7,5	120
	25,6	40,5	9	24	0,8	1	36,5	4	M20×1,5	21	10	-	-	-	NIPA2×7,5	120
62	30,6	49,5	11	29	0,8	1	44	4	M24×1,5	25	14	28	22	1	NIPA3×9,5	220
	30,6	49,5	11	29	0,8	1	44	4	M24×1,5	25	14	-	-	-	NIPA3×9,5	220
72	30,6	49,5	11	29	0,8	1,1	44	4	M24×1,5	25	14	28	22	1	NIPA3×9,5	220
	30,6	49,5	11	29	0,8	1,1	44	4	M24×1,5	25	14	-	-	-	NIPA3×9,5	220
80	37	63	15	35	1	1,1	53	4	M30×1,5	32	14	35	29	1,5	NIPA3×9,5	450
	37	63	15	35	1	1,1	53	4	M30×1,5	32	14	-	-	-	NIPA3×9,5	450
90	37	63	15	35	1	1,1	53	4	M30×1,5	32	14	35	29	1,5	NIPA3×9,5	450
	37	63	15	35	1	1,1	53	4	M30×1,5	32	14	-	-	-	NIPA3×9,5	450





Stud type cylindrical roller bearing track rollers

With axial guidance

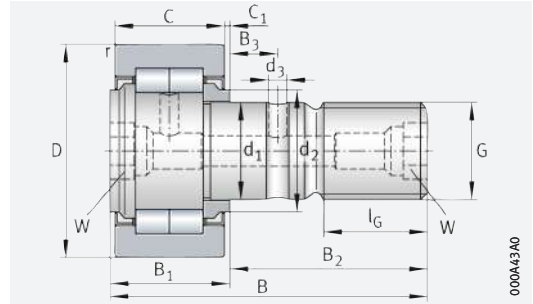

NUKR, with optimised INA profile

D = 35 – 90 mm

Main dimensions			Basic load ratings				Fatigue limit load C_{urw}	Speed n_{DG}	Mass m	Without eccentric collar Designation ▶ 1398 1.12 ▶ 1399 1.13 X-life ▶ 1384	Mass m	With eccentric collar Designation ▶ 1398 1.12 ▶ 1399 1.13 X-life ▶ 1384
D	d_1	B	dyn. C_{rw}	stat. C_{Orw}	dyn. F_{rper}	stat. F_{Oper}						
	h7		N	N	N	N	min ⁻¹					
35	16	52	15 300	18 700	8 500	16 800	2 430	6 500	164	NUKR35	–	–
	16	52	15 300	18 700	8 500	16 800	2 430	6 500	–	–	177	NUKRE35
	16	52	12 600	14 600	10 700	14 600	1 760	6 000	164	PWKR35-2RS-XL	–	–
	16	52	12 600	14 600	10 700	14 600	1 760	6 000	–	–	177	PWKRE35-2RS-XL
40	18	58	18 700	24 900	13 000	24 900	3 150	5 500	242	NUKR40	–	–
	18	58	18 700	24 900	13 000	24 900	3 150	5 500	–	–	258	NUKRE40
	18	58	14 300	17 900	16 500	17 900	2 160	5 000	242	PWKR40-2RS-XL	–	–
	18	58	14 300	17 900	16 500	17 900	2 160	5 000	–	–	258	PWKRE40-2RS-XL
47	20	66	28 500	37 500	16 200	32 500	4 850	4 200	380	NUKR47	400	NUKRE47
	20	66	24 500	30 500	20 700	30 500	3 750	3 800	380	PWKR47-2RS-XL	400	PWKRE47-2RS-XL
52	20	66	29 000	40 500	17 100	34 000	5 300	4 200	450	NUKR52	470	NUKRE52
	20	66	25 000	33 000	21 800	33 000	4 100	3 800	450	PWKR52-2RS-XL	470	PWKRE52-2RS-XL
62	24	80	40 000	55 000	23 400	46 000	7 300	2 600	795	NUKR62	824	NUKRE62
	24	80	35 000	45 500	29 000	45 500	5 800	2 200	795	PWKR62-2RS-XL	824	PWKRE62-2RS-XL
72	24	80	45 000	65 000	31 500	63 000	8 700	2 600	1 020	NUKR72	1 050	NUKRE72
	24	80	38 500	54 000	39 000	54 000	6 900	2 200	1 020	PWKR72-2RS-XL	1 050	PWKRE72-2RS-XL
80	30	100	69 000	104 000	47 500	95 000	14 100	1 800	1 600	NUKR80	1 670	NUKRE80
	30	100	56 000	79 000	60 000	79 000	10 600	1 800	1 600	PWKR80-2RS-XL	1 670	PWKRE80-2RS-XL
90	30	100	78 000	123 000	76 000	123 000	16 700	1 800	1 960	NUKR90	2 020	NUKRE90
	30	100	62 000	92 000	92 000	92 000	12 200	1 800	1 960	PWKR90-2RS-XL	2 020	PWKRE90-2RS-XL

medias ▶ <https://www.schaeffler.de/std/1E25>

- 1) Drive fit lubrication nipples are supplied loose. Only these lubrication nipples should be used.
- 2) Nominal dimension for hexagonal socket.
Suitable central lubrication adapter for connection to a central lubrication system ▶ 1393.

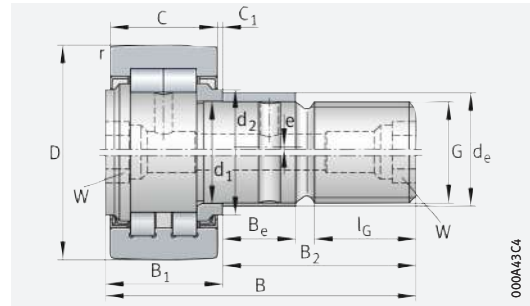
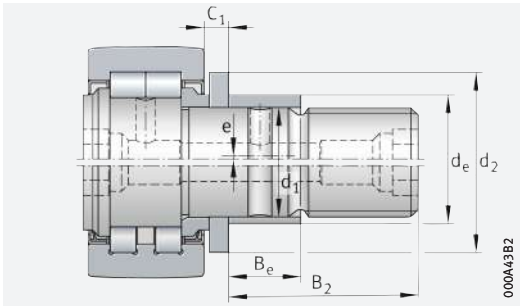

NUKRE35/NUKRE40 (top)
PWKRE35-2RS/PWKRE40-2RS (bottom)
with optimised INA profile

NUKRE (top)
PWKRE..-2RS (bottom)
with optimised INA profile

Dimensions														Drive fit lubrication nipple ¹⁾	Nut tightening torque M _A		
D	B ₁	B ₂	B ₃	C	C ₁	r	d ₂	d ₃	G	l _G	W ²⁾	Eccentric collar				Nm	
	max.					min.						d _e	B _e				e
35	19,6	32,5	7,8	18	0,8	0,6	20	3	M16×1,5	17	8	-	-	-	NIPA2×7,5		58
	22,6	29,5	-	18	3,8	0,6	27,6	-	M16×1,5	17	8	20	12	1	NIPA2×7,5	58	
	19,6	32,5	7,8	18	0,8	0,6	20	3	M16×1,5	17	8	-	-	-	NIPA2×7,5	58	
	22,6	29,5	-	18	3,8	0,6	27,6	-	M16×1,5	17	8	20	12	1	NIPA2×7,5	58	
40	21,6	36,5	8	20	0,8	1	22	3	M18×1,5	19	8	-	-	-	NIPA2×7,5	87	
	24,6	33,5	-	20	3,8	1	30	-	M18×1,5	19	8	22	14	1	NIPA2×7,5	87	
	21,6	36,5	8	20	0,8	1	22	3	M18×1,5	19	8	-	-	-	NIPA2×7,5	87	
	24,6	33,5	-	20	3,8	1	30	-	M18×1,5	19	8	22	14	1	NIPA2×7,5	87	
47	25,6	40,5	9	24	0,8	1	27	4	M20×1,5	21	10	24	18	1	NIPA2×7,5	120	
	25,6	40,5	9	24	0,8	1	27	4	M20×1,5	21	10	24	18	1	NIPA2×7,5	120	
52	25,6	40,5	9	24	0,8	1	31	4	M20×1,5	21	10	24	18	1	NIPA2×7,5	120	
	25,6	40,5	9	24	0,8	1	31	4	M20×1,5	21	10	24	18	1	NIPA2×7,5	120	
62	30,6	49,5	11	28	1,3	1	38	4	M24×1,5	25	14	28	22	1	NIPA3×9,5	220	
	30,6	49,5	11	28	1,3	1	38	4	M24×1,5	25	14	28	22	1	NIPA3×9,5	220	
72	30,6	49,5	11	28	1,3	1,1	44	4	M24×1,5	25	14	28	22	1	NIPA3×9,5	220	
	30,6	49,5	11	28	1,3	1,1	44	4	M24×1,5	25	14	28	22	1	NIPA3×9,5	220	
80	37	63	15	35	1	1,1	47	4	M30×1,5	32	14	35	29	1,5	NIPA3×9,5	450	
	37	63	15	35	1	1,1	47	4	M30×1,5	32	14	35	29	1,5	NIPA3×9,5	450	
90	37	63	15	35	1	1,1	47	4	M30×1,5	32	14	35	29	1,5	NIPA3×9,5	450	
	37	63	15	35	1	1,1	47	4	M30×1,5	32	14	35	29	1,5	NIPA3×9,5	450	

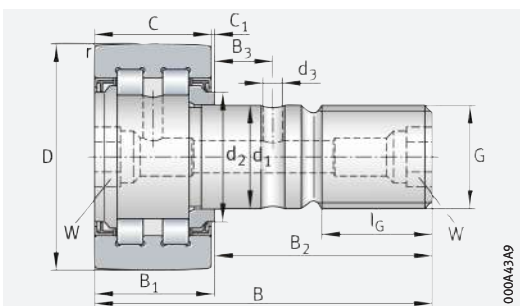

PWKR..-2RS, with optimised INA profile

2 Yoke type ball bearing track rollers, stud type ball bearing track rollers



Ball bearing track rollers:

- are ready-to-fit, single or double row rolling bearings based on deep groove or angular contact ball bearings ▶1429|☐2 to ▶1431|☐6
- are supplied with or without a stud (designs without a stud are mounted on shafts or studs)
- have particularly thick-walled outer rings with a crowned or cylindrical outside surface ▶1428|2.1
- can support high radial loads ▶1431|2.2
- tolerate axial loads which are due to small misalignment defects, skewed running or temporary contact running impacts
- are sealed on both sides ▶1432|2.5
- are also available with a plastic tyre on the outer ring for low-noise running ▶1428|2.1, ▶1431|☐6
- are not mounted in a housing bore, but are supported on a flat mating track ▶1428|☐1 and ▶1430|☐5
- can be adjusted to the mating track in the design with the eccentric collar, thus permitting, for example, larger manufacturing tolerances in the adjacent construction.

① 1
Double row stud type track roller supported on a flat mating track

① Mating track

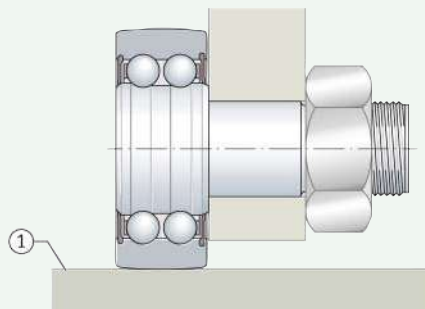

2.1 Bearing design

Design variants

The bearings are available as:

- yoke type track rollers (single or double row) ▶1429|☐2
- stud type track rollers (single or double row) ▶1430|☐3 to ▶1430|☐5
- track rollers with plastic outer tyre ▶1431|☐6.

Ball bearing track rollers (general)

Characterised by a thick-walled outer ring

Ball bearing track rollers are self-retaining, single or double row ball bearings with particularly thick-walled outer rings. In addition to high radial forces, these bearings can also support axial forces in both directions. Ball bearing track rollers are available for various applications with an inner ring, with a stud and with a plastic tyre on the outer ring ▶1429|☐2 to ▶1431|☐6.

🔗 **Applications** Typical areas of application of these products include cam gears, bed ways, conveying equipment and linear guidance systems.

🔗 **Spherical or cylindrical outside surface** Yoke type track rollers and stud type track rollers with a crowned outside surface have a radius of curvature of $R = 500 \text{ mm}$. Yoke type track rollers with a cylindrical outside surface have the suffix X ▶ 1435 | 3.

🔗 **The crowned outside surface prevents edge stresses under skewing** Yoke type track rollers with a crowned outside surface are used where skewing can occur relative to the mating track. The crowned design reduces the risk of edge stresses ▶ 1391.

🔗 **Special coating Corrotect** For applications requiring increased protection against corrosion, yoke type track rollers with the special Cr(VI)-free coating Corrotect are available by agreement as a special design; description of Corrotect ▶ 1389.

Yoke type track rollers

🔗 **Comparable in design to deep groove or angular contact ball bearings** Yoke type track rollers are similar in construction to deep groove or angular contact ball bearings and are mounted on shafts or studs ▶ 1429 | 2. They have outer rings with a crowned or cylindrical outside surface, inner rings and ball and cage assemblies with plastic cages. Yoke type track rollers LR6, LR60 and LR2 are single row, LR50, LR52 and LR53 are double row.

Double row design

🔗 **LR52, LR53** While the outer dimensions remain unchanged, the internal construction of yoke type track rollers LR52 and LR53 has been optimised. This has brought about an increase in load carrying capacity and speed in continuous operation, and in grease lubrication n_{DG} . These yoke type track rollers are X-life bearings ▶ 1431.

2
Yoke type track rollers, sealed on both sides

F_r = radial load
 F_a = axial load

- ① Single row, lip seals, with radial sealing action (LR6..-2RSR)
- ② Double row, sealing shields (LR52..-2Z)

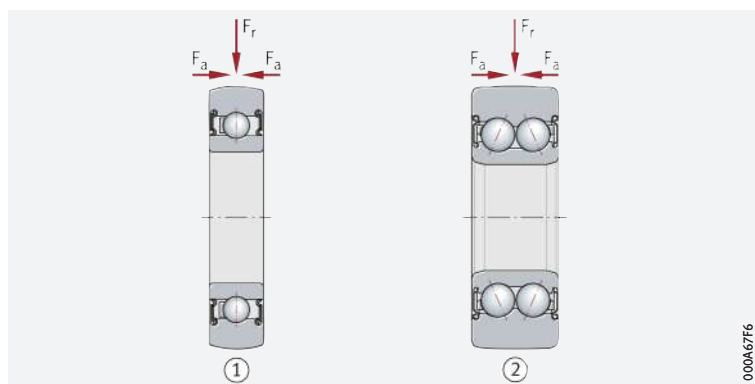

Stud type track rollers

🔗 **Heavy-section roller stud, with or without eccentric collar** Stud type track rollers have outer rings with a crowned outside surface, heavy-section roller studs and ball and cage assemblies with plastic cages ▶ 1430 | 3 and ▶ 1430 | 4. The yoke type track rollers are available with and without an eccentric collar.

For ease of mounting, the roller stud is produced in one of the following designs:

- with a threaded hole and mounting slot ▶ 1430 | 3
- with an external thread and hexagonal socket ▶ 1430 | 4
- with an external thread and flat areas on both sides ▶ 1430 | 5.

Track rollers ZL2 are single row, ZL52, ZLE52 and KR52 are double row.

🔗 **Design without eccentric collar** Stud type track rollers without an eccentric collar are suitable for applications where a defined requirement for adjustment of the outer ring outside surface in relation to the mating track on the adjacent construction is not present ▶ 1430 | 3 and ▶ 1430 | 4.



Stud type track rollers, without eccentric collar, short roller stud with threaded hole, sealed on both sides

F_r = radial load

F_a = axial load

- ① Single row, lip seal on stud side plus sealing shield and cover (ZL...-DRS)
- ② Double row, lip seal on stud side plus sealing shield and cover (ZL52...-DRS)

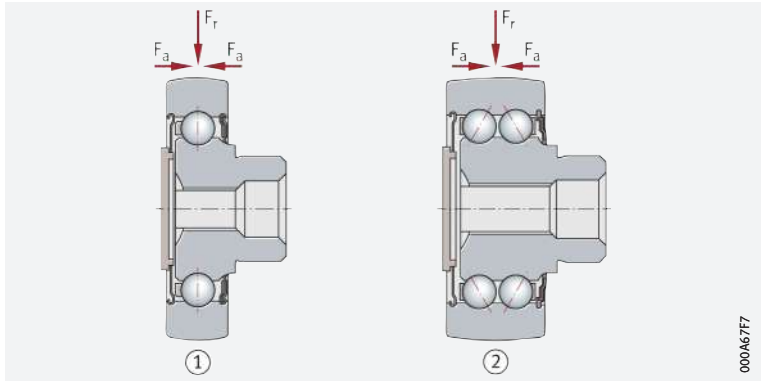

000A67F7



Stud type track roller, without eccentric collar, long roller stud with external thread, sealed on both sides

F_r = radial load

F_a = axial load

- ① Double row, lip seals, with axial sealing action (KR52...-2RS)

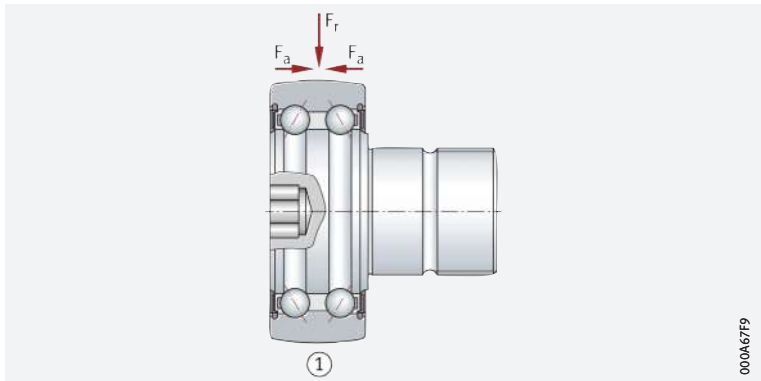

000A67F9

Design with eccentric collar

Stud type track rollers ZLE52 have an eccentric collar **▶ 1430** | 5.

The eccentric collar can be used to adjust the outside surface of the outer ring clearance-free against the mating track. This gives optimum geometrical locking between the track roller and mating track. Furthermore, larger manufacturing tolerances can be tolerated in the adjacent construction. The load distribution when several stud type track rollers are used is also more uniform. For countertensioning during fitting, this series has flat areas on both sides of the roller stud. Threaded connections must be provided on the two end faces for relubrication, dimensions **▶ 1446** |



Stud type track roller, with eccentric collar, long roller stud with external thread, sealed on both sides

F_r = radial load

F_a = axial load

- ① Double row, sealing shields (ZLE52...-2Z)

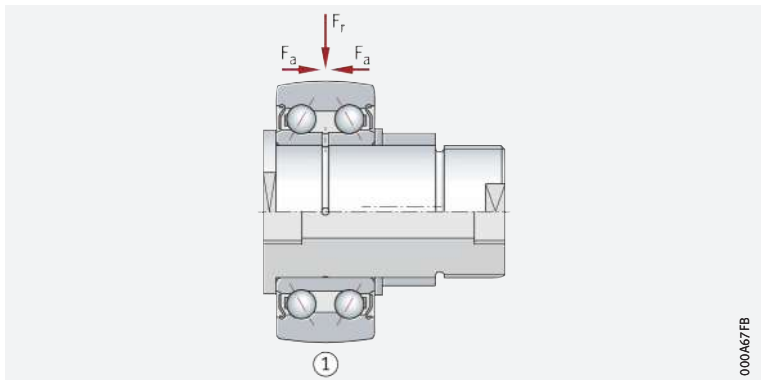

000A67FB

Track rollers with plastic outer tyre

Suitable for low loads and high demands on low-noise running

Track rollers KLRU and KLRZ comprise single row deep groove ball bearings with a shrink-fitted polyamide outer ring (PA) **▶ 1431** | 6. Polyamide can tolerate higher specific contact pressures than elastomer and is relatively resistant to abrasion. These track rollers are mounted on shafts or studs and are used where low loads are present and the bearings are required to run particularly quietly.

Spherical or cylindrical outside surface

Outside surface profile of the outer ring

Track rollers KLRU have an outer ring with a crowned outside surface. The radius of curvature is indicated in the product table. Series KLRZ has a cylindrical outside surface.



Maximum radial load

The maximum radial load is determined by the permissible contact pressure; the values $F_{r\text{per}}$ in the product tables must not be exceeded.



Track rollers with plastic outer tyre, sealed on both sides

F_r = radial load
 F_a = axial load

- ① Crowned outside surface, sealing shields (KLRU..-2Z)
- ② Cylindrical outside surface, sealing shields (KLRZ..-2Z)

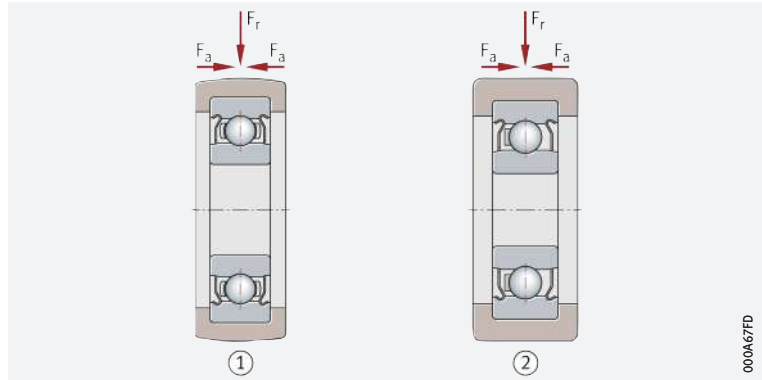

X-life

X-life premium quality

Track rollers LR52 and LR53, which have undergone comprehensive further development, are supplied in the X-life design. These track rollers are characterised by a longer rating life and operating life, due to higher basic dynamic load ratings compared with standard track rollers.

This higher performance results from the use of state of the art manufacturing techniques and improved internal constructions. They lead to better and more uniform surfaces and contact areas and thus optimised load distribution in the bearing.

Increased customer benefits due to X-life

This opens up expanded design possibilities:

- Under the same load and with an unchanged design envelope, X-life bearings have a longer rating life. Maintenance intervals can be extended
- Conversely, an X-life bearing in the same design envelope and with the same rating life can support higher loads
- Where the rating life and load remain unchanged, X-life bearings allow higher performance density, facilitating optimisation of the design envelope and reductions in mass.



Lower operating costs, higher machine availability

In conclusion, these advantages improve the overall cost-efficiency of the bearing position significantly and thus bring about a sustainable increase in the efficiency of the machine and equipment.

Suffix XL

X-life track rollers include the suffix XL in the designation.

2.2

Load carrying capacity

Suitable for high radial loads

The track rollers can support high radial loads as well as axial loads arising from slight misalignment and skewed running.

If used as a track roller, the outer ring undergoes elastic deformation

Installation as track roller

In the case of track rollers, the outer ring is supported on the mating track at certain points and undergoes elastic deformation (oval deformation) ➤ 1432 | 7. Compared to rolling bearings supported in a housing bore, track rollers therefore have:

- a modified load distribution in the bearing (load is supported by fewer rolling elements in the loaded zone). This is taken into consideration by the reduced effective basic load ratings $C_{r\text{w}}$ and $C_{0r\text{w}}$ used in the calculation of the rating life.

- bending stresses and reverse bending strengths in the outer ring. These are taken into consideration by the permissible effective radial loads $F_{r\text{ per}}$ and $F_{Or\text{ per}}$. The bending stresses and reverse bending strengths must not exceed the permissible strength values of the material.

 7
Installation as track roller:
deformation of the outer ring when
used against a flat mating track

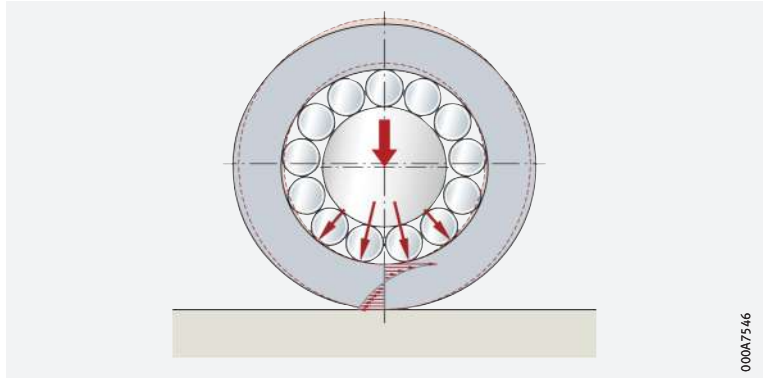

2.3 Compensation of angular misalignments

 Not suitable for the compensation of angular misalignments

Track rollers are not suitable for the compensation of angular misalignments, but can tolerate small misalignments and slight skewed running; for limits see chapter Yoke type roller bearing track rollers, stud type roller bearing track rollers ► 1380

 Skewed running

Skewed running leads to additional axial loading of the bearing and to elastic axial slippage in rolling contact between the outer ring and the mating track.

 Tilted running

If tilting occurs during running, increased edge stresses occur, especially in track rollers with a cylindrical outside surface of the outer ring. Track rollers with a crowned outer ring are less sensitive to tilting and should therefore be used in preference if tilting is expected.

2.4 Lubrication

 Greased using a grease to GA13

The track rollers are greased using a lithium soap grease to GA13. In the case of stud type track rollers, series ZLE52 can be lubricated via the roller stud. Track rollers with a plastic outer tyre cannot be relubricated. Suitable greases for relubrication ► 1392 |  1.

 LR52, LR53

Double row track rollers are also greased using a lithium soap grease to GA13. Due to the improved internal construction, less friction occurs and less strain is placed on the lubricant. This leads to lower bearing temperatures.

Two contact zones

Two contact zones must be lubricated and considered separately:

- the rolling elements and rolling element raceway
- the outside surface of the track roller and the mating track.

 Lubricate the rolling elements and mating track



Track rollers are also available as a special design with a lubrication hole in the inner ring. These bearings have the suffix IS1 ► 1435 |  3.

2.5 Sealing

 Bearings with the suffix 2RSR

Yoke type track rollers

Yoke type track rollers with the suffix 2RSR have lip seals with radial sealing action on both sides. In some sizes, RS seals with axial sealing action are fitted for reasons of space.

- 2HRS or 2Z seal Double row yoke type track rollers in X-life quality have a revised sealing concept with a significantly improved sealing action compared to the previous design ► 1433 | 8. Further information on HRS seals ► 219 | 2. As standard, the bearings (suffix 2HRS) have DEHP-free lip seals on both sides.



Lip seal 2HRS or sealing shield 2Z

- Innovative geometry of lip seal 2HRS with axial contact between sealing ring and inner ring
- Sealing shield 2Z with labyrinth seal

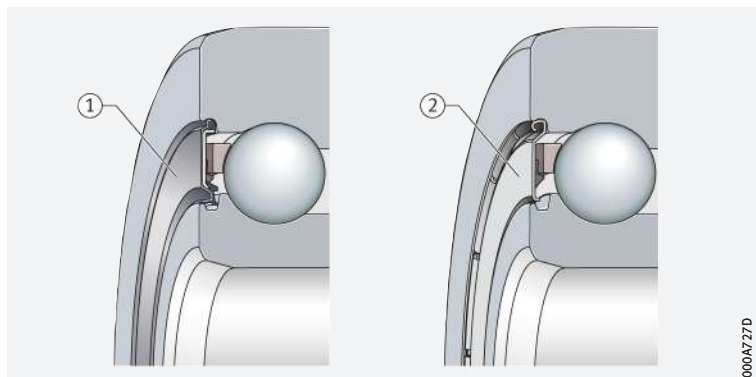

Stud type track rollers

- Series ZL2 and ZL52 Stud type track rollers ZL2 and ZL52 have lip seals on the stud side and the suffix DRS. The opposite side can be sealed using the plastic cover supplied.
- Series ZLE52 Stud type track rollers ZLE52 have sealing shields on both sides and the suffix 2Z.

Track rollers with plastic outer tyre

- Sealing shields or lip seals These track rollers have sealing shields on both sides (suffix 2Z) or lip seals with radial sealing action (suffix 2RSR).

2.6 Speeds

- Speeds n_{DG} The maximum permissible speed for track rollers is essentially determined by the permissible operating temperature of the track rollers. The speed thus depends on the type of bearing, the load, the lubrication conditions and the cooling conditions.
 - Speeds with lip seals The speed of track rollers with lip seals is additionally restricted by the permissible sliding speed at the seal lip.
 - Speeds during continuous operation The speeds n_{DG} in the product tables are guide values and are valid for grease lubrication.
- !** Additional information on the subject of speeds in the chapter Yoke type roller bearing track rollers, stud type roller bearing track rollers must be observed ► 1396 | 1.6.

2.7 Noise

Schaeffler Noise Index

The Schaeffler Noise Index (SGI) is not yet available for this bearing type ► 69. The data for these bearing series will be introduced and updated in stages.

Further information:

- medias ► <https://medias.schaeffler.com>.



2.8 Temperature range

 **Limiting values**

The operating temperature of the track rollers is limited by:

- the dimensional stability of the bearing rings and rolling elements
- the cage
- the lubricant
- the seals
- the plastic outer tyre.

Possible operating temperatures of the track rollers ► 1434 |  1.

 **1**
Permissible temperature ranges

Operating temperature	Yoke type track rollers	
	with plastic outer tyre KLRU and KLRZ	without plastic outer tyre
	-20 °C to +80 °C	-20 °C to +120 °C



In the event of anticipated temperatures which lie outside the stated values, please contact Schaeffler.

2.9 Cages

 **Solid cages made from polyamide PA66 are used as standard**

The cages used in the track rollers are plastic cages made from glass fibre reinforced polyamide PA66. These cages have a low mass as well as good sliding and emergency running characteristics. Track rollers in the X-life design have an optimised polyamide cage as standard.

2.10 Internal clearance

 **The standard is CN**

Radial internal clearance

Track rollers are manufactured as standard with radial internal clearance CN (normal) ► 1434 |  2. CN is not stated in the designation.



The values for radial internal clearance correspond to DIN 620-4:2004 (ISO 5753-1:2009). These are valid for bearings which are free from load and measurement forces (without elastic deformation).

 **2**
Radial internal clearance for yoke and stud type track rollers

Nominal bore diameter d		Radial internal clearance									
		C2 (Group 2)		CN (Group N)		C3 (Group 3)		C4 (Group 4)		C5 (Group 5)	
mm		µm		µm		µm		µm		µm	
over	incl.	min.	max.	min.	max.	min.	max.	min.	max.	min.	max.
2,5	10	0	7	2	13	8	23	14	29	20	37
10	18	0	9	3	18	11	25	18	33	25	45
18	24	0	10	5	20	13	28	20	36	28	48
24	30	1	11	5	20	13	28	23	41	30	53
30	40	1	11	6	20	15	33	28	46	40	64
40	50	1	11	6	23	18	36	30	51	45	73
50	65	1	15	8	28	23	43	38	61	55	90

2.11 Dimensions, tolerances



Tolerances

The tolerances for the dimensional and running accuracy of track rollers correspond to tolerance class Normal in accordance with ISO 492:2014. In a deviation from ISO 492, the diameter tolerance of the profiled outside surface is 0/-0,05 mm.

Stud tolerances

The stud diameter tolerances for stud type track rollers are:

- in tolerance class r6 for ZL2 and ZL52
- in tolerance class h7 for KR52
- in tolerance class h9 for ZLE52.

2.12 Suffixes

For a description of the suffixes used in this chapter ▶ 1435 | 3 and **medias** interchange ▶ <https://www.schaeffler.de/std/1D52>.

3
Suffixes and corresponding descriptions

Suffix	Description of suffix	Standard
DRS	Lip seal on stud side, axial sealing action Sealing shield with cover on the end face	Standard
IS1	Lubrication hole in inner ring	Special design, available by agreement
RR	Protected against corrosion by Corroprotect special coating	
TVH	Cage made from glass fibre reinforced polyamide	Standard
X	Cylindrical outside surface	
XL	X-life design	
2HRS	Lip seal on both sides with optimised geometry, low friction	
2RS	Lip seal on both sides, with axial sealing action	
2RSR	Lip seal on both sides, with radial sealing action	
2Z	Sealing shield on both sides	



2.13 Structure of bearing designation

Examples of composition of bearing designation

The designation of bearings follows a set model. Examples ▶ 1435 | 9 to ▶ 1436 | 11.

9
Single row yoke type track roller, lip seal on both sides: designation structure

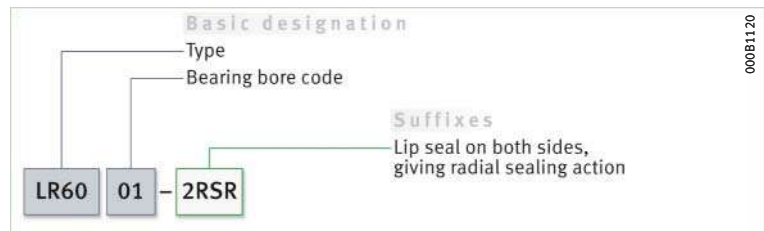

10
Double row yoke type track roller, 2HRS seal on both sides, cage made from glass fibre reinforced polyamide, X-life design: designation structure

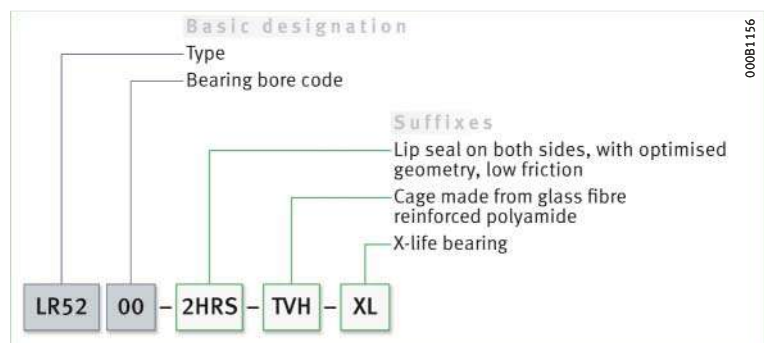

11
 Double row stud type track roller with eccentric collar, sealing shield on both sides: designation structure



2.14 Dimensioning

Calculation of the rating life

The methods for calculating the rating life are:

- the basic rating life to DIN ISO 281
- the adjusted basic rating life to DIN ISO 281
- the expanded calculation of the adjusted reference rating life to DIN ISO 281-4.

Use effective basic dynamic/ static load ratings

These methods are described in the chapter Load carrying capacity and life. For track rollers, the following values must be replaced:

- $C_r, C_{Or} = C_{rw}, C_{Orw}$
Effective basic dynamic or static load rating
- $C_{ur} = C_{urw}$
Fatigue limit load as track roller.



Further equations for calculating the rating life are given in the chapter Yoke type roller bearing track rollers, stud type roller bearing track rollers. The instructions and information provided there must be observed.

Static load safety factor

$S_0 = C_{Orw} / F_{Or}$

In addition to the basic rating life L, it is also always necessary to check the static load safety factor $S_0 \geq 1.436$.

1
 Static load safety factor

$$S_0 = \frac{C_{Orw}}{F_{Or}}$$

Legend

S_0	-	Static load safety factor
C_{Orw}	N	Effective radial basic static load rating in accordance with product table
F_{Or}	N	Maximum static radial load on track roller.



Track rollers are regarded as heavily loaded at a static load safety factor of $S_0 < 8$. Static load safety factors of $S_0 < 1$ cause plastic deformation of the rolling elements and the raceways, which can impair smooth running. This is only permissible for bearings with small rotary motions or in secondary applications.



If an application has a static load safety factor $S_0 < 2$, please consult Schaeffler.

2.15 Minimum load

Minimum load
 $C_{Orw} / F_r < 60$

In order to ensure that the outer ring is driven, that no slippage occurs and that the track roller does not lift from the mating track, the track roller must be subjected to a minimum load in dynamic operation. In general, the minimum load is calculated using the ratio $C_{Orw} / F_r < 60$.

2.16 Design of bearing arrangements

☞ *The value for dimension “ d_2 ” must not be less than the value stated*

☞ *Yoke type track rollers LR*

☞ *Tolerance class h6* ⓘ

☞ *The value for dimension “ d_2 ” must not be less than the value stated*

☞ *Lead chamfer*



☞ *Tolerance class H7* ⓘ

Adjacent construction of yoke type track rollers

The abutment surfaces for the bearings must be flat and perpendicular. Due to the contact pressure occurring, they must not be less than the dimension d_2 ; see product tables for values ▶ 1440 |

Yoke type track rollers LR can be axially clamped or located by means of conventional fasteners such as snap rings.

Shaft tolerances

In general, yoke type track rollers have point load on the inner ring. In order to ensure adequate support and to largely avoid fretting corrosion, the shaft tolerance should be in the tolerance class h6 ⓘ.

Adjacent construction of stud type track rollers

The abutment surfaces for the track rollers must be flat and perpendicular. Due to the contact pressure occurring, they must not be less than the dimension d_2 ; see product tables for values ▶ 1444 |

The lead chamfer on the locating bore must not be more than $0,5 \times 45^\circ$.

Stud type track rollers ZL and KR must be axially clamped. The abutment surface for the nut must have sufficiently high strength and the tightening torque M_A for the fixing nut must be observed; see product table for values ▶ 1444 | . The roller stud can only transmit the permissible radial load if the correct tightening torque is applied. If the tightening torque for the nut cannot be adhered to, an interference fit is required.

Locating bore tolerance

For series ZL2, ZL52, KR52 and ZLE52, Schaeffler recommends locating bores to tolerance class H7 ⓘ.

2.17 Mounting and dismounting



The mounting and dismounting options for track rollers, by mechanical or hydraulic methods, must be taken into consideration in the design of the bearing position.



Schaeffler Mounting Handbook

☞ *Rolling bearings must be handled with great care*

Rolling bearings are well-proven precision machine elements for the design of economical and reliable bearing arrangements, which offer high operational security. In order that these products can function correctly and achieve the envisaged operating life without detrimental effect, they must be handled with care.



The Schaeffler Mounting Handbook MH 1 gives comprehensive information about the correct storage, mounting, dismounting and maintenance of rotary rolling bearings ▶ <https://www.schaeffler.de/std/1D53>. It also provides information which should be observed by the designer, in relation to the mounting, dismounting and maintenance of bearings, in the original design of the bearing position. This book is available from Schaeffler on request.

Mounting guidelines for yoke type track rollers

Guidelines

If the tolerances are unfavourable, the yoke type track rollers should be pressed onto the shaft or stud using a mounting press [▶ 1438](#) | [12](#). The inner ring must be fitted such that the pressing-in force is distributed uniformly on the end face of the inner ring. The press-in force must not be directed through the rolling elements. Ensure that the seals are not damaged while mounting the yoke type track rollers. Yoke type track rollers must be secured axially after mounting.

12
Mounting of yoke type track roller using a mounting press

① Mounting press

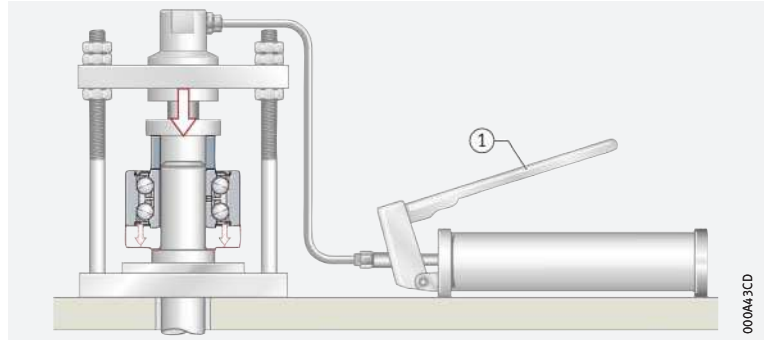

Stud type track rollers

Guidelines for mounting

Stud type track rollers are mounted and dismounted using the methods applied to yoke type track rollers [▶ 1438](#) | [13](#). The tightening torques M_A given in the product tables must be observed. It is only in this way that the permissible radial load can be ensured. Screws and nuts of grade 8.8 or better must be used.

13
Mounting of stud type track roller

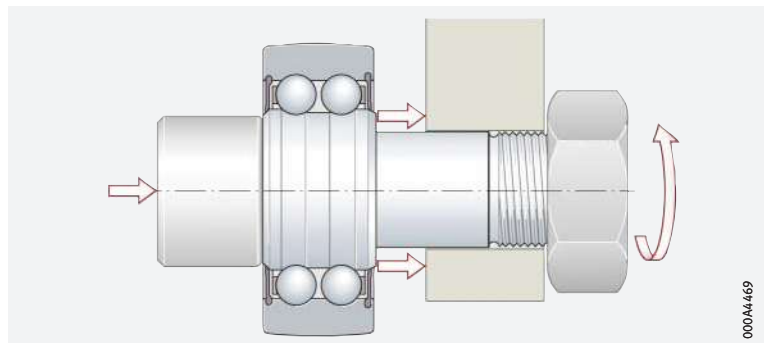

2.18 Legal notice regarding data freshness

The further development of products may also result in technical changes to catalogue products

Of central interest to Schaeffler is the further development and optimisation of its products and the satisfaction of its customers. In order that you, as the customer, can keep yourself optimally informed about the progress that is being made here and with regard to the current technical status of the products, we publish any product changes which differ from the printed version in our electronic product catalogue.



We therefore reserve the right to make changes to the data and illustrations in this catalogue. This catalogue reflects the status at the time of printing. More recent publications released by us (as printed or digital media) will automatically precede this catalogue if they involve the same subject. Therefore, please always use our electronic product catalogue to check whether more up-to-date information or modification notices exist for your desired product.

Link to electronic product catalogue



The following link will take you to the Schaeffler electronic product catalogue: ► <https://medias.schaeffler.com>.

2.19 Further information



For reliable and problem-free operation of track rollers, it is essential that attention is paid to the following information in the chapter Yoke type roller bearing track rollers, stud type roller bearing track rollers:

- installation as yoke or stud type track roller ► 1390
- permissible dynamic or static radial load ► 1391
- load carrying capacity and life ► 1400
- operating life ► 1400
- minimum load ► 1402
- angular misalignment and tilting ► 1391
- speeds ► 1396
- lubrication ► 1392.





Yoke type ball bearing track rollers

Single row
Sealed

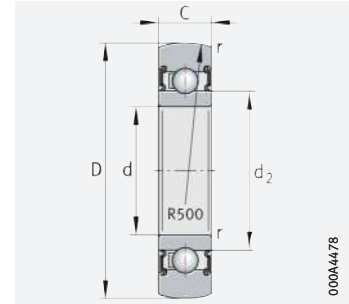

With seal 2RSR, 2RS

D = 13 – 90 mm

Main dimensions			Basic load ratings		Fatigue limit load C_{urw} N	Speed n_{DG} min^{-1}	Mass m \approx g	Designation ➤ 1435 2.12 ➤ 1435 2.13	Dimensions	
D	d	C	dyn. C_{rw} N	stat. C_{0rw} N					d_2	r min.
13	4	4	920	350	18,1	24 000	10	LR604-2RSR	6,1	0,2
16	5	5	1 290	510	25,5	23 000	10	LR605-2RSR	7,5	0,2
19	6	6	1 940	790	39,5	22 000	10	LR606-2RSR	8,7	0,3
22	7	6	2 250	880	42,5	20 000	10	LR607-2RSR	9	0,3
24	8	7	2 950	1 240	63	19 000	20	LR608-2RSR	10	0,3
28	10	8	5 000	2 490	126	16 000	20	LR6000-2RSR	14,6	0,3
30	12	8	5 300	2 750	144	15 000	30	LR6001-2RSR	16,6	0,3
	10	9	5 100	2 310	117	13 000	50	LR200-2RSR	16,6	0,6
32	10	9	5 100	2 310	117	13 000	50	LR200-X-2RSR	16,6	0,6
	12	10	6 000	2 750	137	12 000	50	LR201-2RSR	18,3	0,6
35	12	10	6 000	2 750	137	12 000	50	LR201-X-2RSR ¹⁾	18,3	0,6
	15	11	7 000	3 350	170	11 000	70	LR202-2RSR	21	0,6
40	15	11	7 000	3 350	170	11 000	70	LR202-X-2RSR ¹⁾	21	0,6
	17	12	8 900	4 450	223	9 000	110	LR203-2RSR	24	0,6
47	17	12	8 900	4 450	223	9 000	110	LR203-X-2RSR ¹⁾	24	0,6
	20	14	11 300	5 700	295	8 000	150	LR204-2RSR	29	1
52	20	14	11 300	5 700	295	8 000	150	LR204-X-2RSR ¹⁾	29	1
	25	15	13 300	7 100	360	7 000	230	LR205-2RSR	33,5	1
62	25	15	13 300	7 100	360	7 000	230	LR205-X-2RSR ¹⁾	33,5	1
	30	16	17 600	9 700	500	5 500	330	LR206-2RS	37,4	1
72	30	16	17 600	9 700	500	5 500	330	LR206-X-2RS ¹⁾	37,4	1
	35	17	21 900	12 100	640	4 500	400	LR207-2RS	42,4	1,1
80	35	17	21 900	12 100	640	4 500	400	LR207-X-2RS ¹⁾	42,4	1,1
	45	19	23 700	13 700	730	3 600	500	LR209-2RS	53,2	1,1
90	45	19	23 700	13 700	730	3 600	500	LR209-X-2RS ¹⁾	53,2	1,1

medias ➤ <https://www.schaeffler.de/std/1D95>

¹⁾ Track roller with cylindrical outside surface.



Yoke type ball bearing track rollers

Double row
Sealed

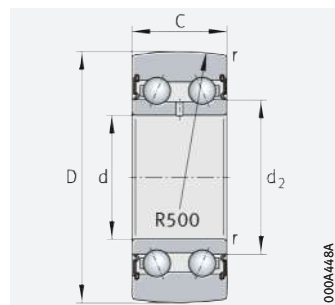

With seal 2RSR, 2RS

D = 17 – 68 mm

Main dimensions			Basic load ratings			Fatigue limit load C_{urw} N	Speed n_{DG} min^{-1}	Mass m \approx g	Designation ► 1435 2.12 ► 1435 2.13	Dimensions	
D	d	C	dyn. C_{rw} N	stat. C_{0rw} N	F_r per N					d_2	r min.
17	5	7	1 690	940	940	48,5	12 000	10	LR50/5-2RSR	8,2	0,2
19	6	9	2 700	1 370	1 370	66	11 000	20	LR50/6-2RSR	9,3	0,3
22	7	10	3 300	1 700	1 700	81	10 000	20	LR50/7-2RSR	10,5	0,3
24	8	11	4 300	2 390	2 390	119	10 000	30	LR50/8-2RSR	10,5	0,3
28	10	12	4 750	2 850	2 850	145	9 000	30	LR5000-2RS	13,5	0,3
30	12	12	5 100	3 100	3 100	161	8 500	30	LR5001-2RS	15,5	0,3
35	15	13	6 500	4 150	4 150	217	7 000	50	LR5002-2RS	20,4	0,3
40	17	14	7 800	5 200	5 200	270	6 000	70	LR5003-2RS	21,6	0,3
47	20	16	11 700	7 700	7 700	400	5 500	120	LR5004-2RS	25,2	0,6
52	25	16	11 800	8 200	8 200	440	4 700	150	LR5005-2RS	29,8	0,6
62	30	19	16 100	11 900	11 900	630	4 000	250	LR5006-2RS	35,5	1
68	35	20	17 800	13 300	13 300	720	4 300	300	LR5007-2RS	41,7	1

medias ► <https://www.schaeffler.de/std/1D96>





Yoke type ball bearing track rollers

Double row
Sealed
Without relubrication hole¹⁾

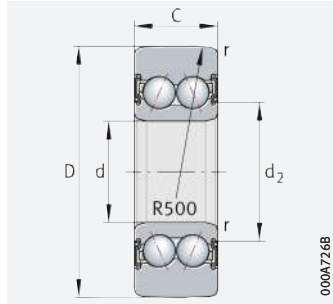

With seal 2HRS

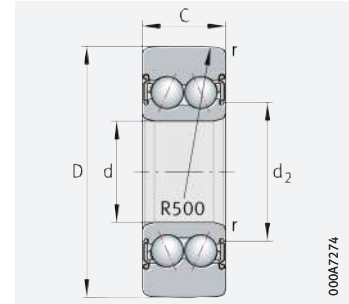

With seal 2Z

D = 32 – 100 mm

Main dimensions			Basic load ratings		Outer ring limit load	Fatigue limit load	Speed	Mass	Designation	Dimensions	
D	d	C	dyn. C _{rw}	stat. C _{0rw}	F _{r per}	C _{urw}	n _{DG}	m	▶ 1435 2.12 ▶ 1435 2.13 X-life ▶ 1431	d ₂	r
			N	N	N	N	min ⁻¹	≈ g		min.	
32	10	14	7 200	4 800	4 800	243	9 200	70	LR5200-2HRS-TVH-XL	17	0,6
	10	14	7 200	4 800	4 800	243	13 000	70	LR5200-2Z-TVH-XL	17	0,6
	10	14	7 200	4 800	4 800	243	13 000	70	LR5200-X-2Z-TVH-XL ²⁾	17	0,6
35	12	15,9	8 800	6 000	4 800	305	8 100	80	LR5201-2HRS-TVH-XL	19,1	0,6
	12	15,9	8 800	6 000	4 800	305	11 100	80	LR5201-2Z-TVH-XL	19,1	0,6
	12	15,9	8 800	6 000	4 800	305	11 100	80	LR5201-X-2Z-TVH-XL ²⁾	19,1	0,6
40	15	15,9	10 800	7 500	7 500	385	7 400	110	LR5202-2HRS-TVH-XL	21	0,6
	15	15,9	10 800	7 500	7 500	385	10 200	110	LR5202-2Z-TVH-XL	21	0,6
	15	15,9	10 800	7 500	7 500	385	10 200	110	LR5202-X-2Z-TVH-XL ²⁾	21	0,6
47	17	17,5	13 700	9 800	9 800	495	6 300	170	LR5203-2HRS-TVH-XL	24,4	0,6
	17	17,5	13 700	9 800	9 800	495	8 900	170	LR5203-2Z-TVH-XL	24,4	0,6
	17	17,5	13 700	9 800	9 800	495	8 900	170	LR5203-X-2Z-TVH-XL ²⁾	24,4	0,6
52	20	20,6	16 900	12 300	10 200	640	5 300	230	LR5204-2HRS-TVH-XL	29,2	1
	20	20,6	16 900	12 300	10 200	640	7 300	230	LR5204-2Z-TVH-XL	29,2	1
	20	20,6	16 900	12 300	10 200	640	7 300	230	LR5204-X-2Z-TVH-XL ²⁾	29,2	1
	17	22,2	19 100	13 400	11 400	670	5 700	210	LR5303-2HRS-TVH-XL	27,1	1
62	25	20,6	19 700	15 400	15 400	790	4 500	340	LR5205-2HRS-TVH-XL	34,2	1
	25	20,6	19 700	15 400	15 400	790	6 500	340	LR5205-2Z-TVH-XL	34,2	1
	25	20,6	19 700	15 400	15 400	790	6 500	340	LR5205-X-2Z-TVH-XL ²⁾	34,2	1
	20	22,2	22 200	16 700	16 700	840	4 850	340	LR5304-2HRS-TVH-XL	31,9	1,1
	20	22,2	22 200	16 700	16 700	840	6 700	340	LR5304-2Z-TVH-XL	31,9	1,1

medias ▶ <https://www.schaeffler.de/std/1D97>

- 1) With relubrication hole by agreement.
- 2) Track roller with cylindrical outside surface.



Main dimensions			Basic load ratings		Outer ring limit load	Fatigue limit load	Speed	Mass	Designation ▶ 1435 2.12 ▶ 1435 2.13 X-life ▶ 1431	Dimensions	
D	d	C	dyn. C _{rw}	stat. C _{0rw}	F _{r per}	C _{ur w}	n _{D G}	m		d ₂	r
			N	N	N	N	min ⁻¹	≈ g			min.
72	30	23,8	26 500	21 400	21 400	1 110	3 800	510	LR5206-2HRS-TVH-XL	40,3	1
	30	23,8	26 500	21 400	21 400	1 110	5 500	510	LR5206-2Z-TVH-XL	40,3	1
	30	23,8	26 500	21 400	21 400	1 110	5 500	510	LR5206-X-2Z-TVH-XL²⁾	40,3	1
	25	25,4	28 000	21 900	21 900	1 110	4 100	500	LR5305-2HRS-TVH-XL	37,6	1,1
	25	25,4	28 000	21 900	21 900	1 110	5 700	500	LR5305-2Z-TVH-XL	37,6	1,1
80	35	27	33 000	26 500	22 200	1 410	3 100	660	LR5207-2HRS-TVH-XL	47	1,1
	35	27	33 000	26 500	22 200	1 410	4 650	660	LR5207-2Z-TVH-XL	47	1,1
	35	27	33 000	26 500	22 200	1 410	4 650	660	LR5207-X-2Z-TVH-XL²⁾	47	1,1
	30	30,2	36 000	28 500	27 000	1 480	3 450	670	LR5306-2HRS-TVH-XL	44,4	1,1
	30	30,2	36 000	28 500	27 000	1 480	4 750	670	LR5306-2Z-TVH-XL	44,4	1,1
85	40	30,2	36 500	30 000	16 300	1 600	2 900	750	LR5208-2HRS-TVH-XL	52,8	1,1
	40	30,2	36 500	30 000	16 300	1 600	4 100	750	LR5208-2Z-TVH-XL	52,8	1,1
	40	30,2	36 500	30 000	16 300	1 600	4 100	750	LR5208-X-2Z-TVH-XL²⁾	52,8	1,1
90	35	34,9	45 500	36 000	27 000	1 820	3 100	970	LR5307-2HRS-TVH-XL	49,6	1,5
	35	34,9	45 500	36 000	27 000	1 820	4 100	970	LR5307-2Z-TVH-XL	49,6	1,5
100	40	36,5	54 000	44 500	35 500	2 310	2 700	1 200	LR5308-2HRS-TVH-XL	56,8	1,5
	40	36,5	54 000	44 500	35 500	2 310	3 650	1 200	LR5308-2Z-TVH-XL	56,8	1,5

medias ▶ <https://www.schaeffler.de/std/1D98>

- 1) Available with relubrication hole by agreement.
 2) Track roller with cylindrical outside surface.





Stud type ball bearing track rollers

Sealed

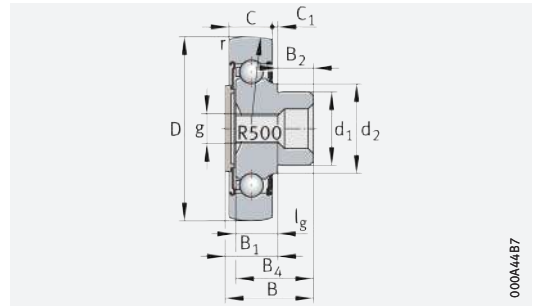

ZL2...-DRS

D = 35 – 80 mm

Main dimensions			Basic load ratings		Fatigue limit load	Speed	Mass	Designation
D	d ₁	B	dyn. C _{r w} N	stat. C _{0 r w} N	C _{u r w} N	n _{D G} min ⁻¹	m ≈ g	▶ 1435 2.12 ▶ 1435 2.13
35	14	33,2	8 700	5 200	260	7 500	90	ZL5201-DRS
	12	49,2	8 700	5 200	260	7 500	120	KR5201-2RS
40	16	23,8	7 000	3 350	170	8 500	80	ZL202-DRS
	16	36,2	10 000	6 300	320	7 000	120	ZL5202-DRS
	16	53,2	10 000	6 300	320	7 000	190	KR5202-2RS
47	18	26,5	8 900	4 450	223	6 500	120	ZL203-DRS
	18	39,5	12 800	8 400	420	5 500	190	ZL5203-DRS
	18	58,8	12 800	8 400	420	5 500	290	KR5203-2RS
52	20	30,7	11 300	5 700	295	6 000	170	ZL204-DRS
	20	45,3	16 100	10 700	550	5 000	250	ZL5204-DRS
	20	63,6	16 100	10 700	550	5 000	380	KR5204-2RS
62	25	33,8	13 300	7 100	360	5 500	250	ZL205-DRS
	25	50,4	18 800	13 200	670	4 500	380	ZL5205-DRS
	24	70,9	18 800	13 200	670	4 500	580	KR5205-2RS
72	30	59	25 000	18 000	930	3 500	550	ZL5206-DRS
	24	74,1	25 000	18 000	930	3 500	800	KR5206-2RS
80	35	69,2	31 000	22 800	1 200	2 800	710	ZL5207-DRS
	30	91	31 000	22 800	1 200	2 800	1 200	KR5207-2RS

medias ▶ <https://www.schaeffler.de/std/1D99>

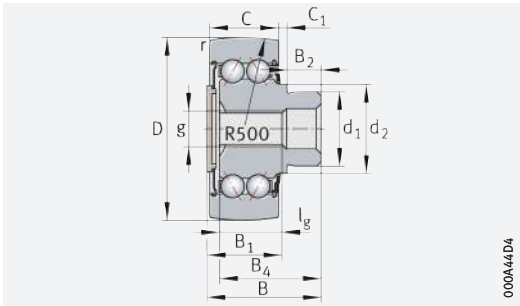

ZL52..-DRS

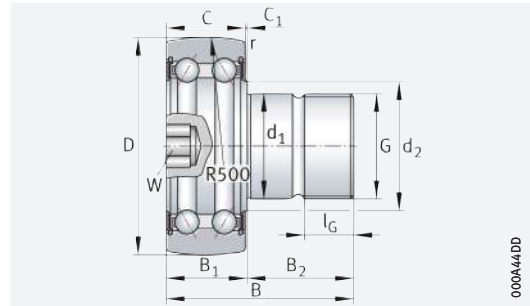

KR52..-2RS

Dimensions													Tightening torque	
D	B ₁	B ₂	B ₄	C	C ₁	d ₂	r	G	l _G	g	l _g	W	M _A	
	max.						min.						Nm	
35	19,5	14	31	15,9	2,6	17,1	0,6	–	–	M8	14	–	–	
	17	32,5	0	15,9	0,8	17,1	0,6	M12×1,5	17	–	–	6	45	
40	14	10	21,5	11	2	20	0,6	–	–	M8	15	–	–	
	20,5	16	34	15,9	3,5	20	0,6	–	–	M8	15	–	–	
	17	36,5	0	15,9	0,8	20	0,6	M16×1,5	19	–	–	8	70	
47	14,5	12	24,5	12	2	22,9	0,6	–	–	M8	16	–	–	
	21,5	18	37,5	17,5	3,5	22,9	0,6	–	–	M8	15	–	–	
	18,5	40,5	0	17,5	0,8	22,9	0,6	M18×1,5	21	–	–	8	115	
52	17	14	28,5	14	2	26,8	1	–	–	M10	18	–	–	
	25,5	20	43	20,6	4	26,8	1	–	–	M10	18	–	–	
	22,5	41,5	0	20,6	1,5	26,8	1	M20×1,5	21	–	–	10	160	
62	18	16	31	15	2	30,3	1	–	–	M10	19	–	–	
	25,5	25	47,5	20,6	4	30,3	1	–	–	M10	18	–	–	
	21,5	49,5	0	20,6	0,8	30,3	1	M24×1,5	25	–	–	10	290	
72	29	30	56,5	23,8	4,5	37,3	1	–	–	M16	20	–	–	
	25	49,5	0	23,8	0,8	37,3	1	M24×1,5	25	–	–	10	290	
80	33,5	36	66,5	27	5,5	42,4	1,1	–	–	M16	20	–	–	
	28	63	0	27	1	42,4	1,1	M30×1,5	32	–	–	12	600	





Stud type ball bearing track rollers

With eccentric collar
Sealed

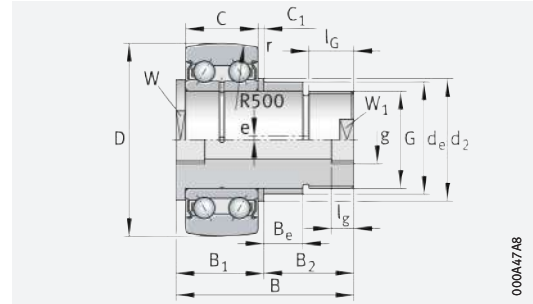

ZLE52...-2Z

D = 35 – 80 mm

Main dimensions			Basic load ratings		Fatigue limit load	Speed	Mass	Designation
D	d _e	B	dyn. C _{rw} N	stat. C _{0rw} N	C _{urw} N	n _{DG} min ⁻¹	m ≈g	► 1435 2.12 ► 1435 2.13
35	18	65,5	8 800	6 000	305	11 100	250	ZLE5201-2Z
40	22	66,5	10 800	7 500	385	10 200	350	ZLE5202-2Z
52	24	76	16 900	12 300	640	7 300	460	ZLE5204-2Z
62	24	88	19 700	15 400	790	6 500	640	ZLE5205-2Z
80	35	99	33 000	26 500	1 410	4 650	1 300	ZLE5207-2Z

Dimensions														Tightening torque	Designation	
D	B ₁ max.	B ₂	C	C ₁	d ₂	r min.	W	W ₁	e	B _e	g	l _g	G	l _G min.	M _A Nm	► 1435 2.12 ► 1435 2.13
35	20,5	45	15,9	2	25	0,6	15	9	1	18	M6	6	M12×1,5	24	30	ZLE5201-2Z
40	21,5	45	15,9	2,5	27	0,6	17	10	1	16	M8×1	8	M14	25	40	ZLE5202-2Z
52	26	50	20,6	2,5	30	1	22	17	1	18	M8×1	8	M20×1,5	29	150	ZLE5204-2Z
62	32	56	20,6	8	30	1	22	17	1	25	M8×1	8	M20×1,5	28	150	ZLE5205-2Z
80	35	64	27	3	45	1,1	40	27	1,5	29	M8×1	8	M30×1,5	32	540	ZLE5207-2Z

medias ► <https://www.schaeffler.de/std/1D9A>



Track rollers

With plastic outer tyre
Sealed

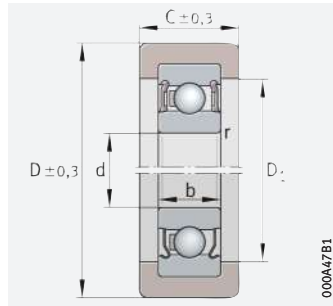

KLRZ..-2RSR (top)
KLRZ..-2Z (bottom)

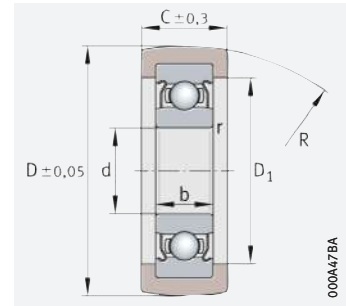

KLRU..-2Z

D = 27,5 – 46,8 mm

Main dimensions			Basic load ratings of track roller ¹⁾ F _{r per}	Deep groove ball bearing fitted	Basic load ratings of deep groove ball bearing		Mass m ≈ g	Designation ▶ 1435 2.12 ▶ 1435 2.13	Dimensions				
D	d	C			dyn. C _r	stat. C _{0r}			b	D ₁	R	r	min.
27,5	+0,05 -0,05	8	11	250	608-2Z	3 500	1 370	16	KLRU08×28×11-2Z	7	20	500	0,3
30	+0,3 -0,3	10	10	250	6000-2Z	4 850	1 970	50	KLRZ10×30×10-2Z	8	24	–	0,3
34,8	+0,05 -0,05	12	12	340	6001-2Z	5 400	2 370	30	KLRU12×35×12-2Z	8	26	300	0,3
41	+0,3 -0,3	12	16	500	6201-2RSR	7 300	3 100	50	KLRZ12×41×16-2RSR	10	29,5	–	0,6
46,8	+0,05 -0,05	12	20	500	6201-2Z	7 300	3 100	45	KLRU12×47×20-2Z	10	28,5	300	0,6
46,8	+0,05 -0,05	15	20	500	6202-2Z	8 200	3 750	50	KLRU15×47×20-2Z	11	31,5	300	0,6

medias ▶ <https://www.schaeffler.de/std/1D9B>

¹⁾ Valid for installation as track roller. The values apply for operating temperatures up to max. +40 °C.



Radial insert ball bearings





Matrix for bearing preselection 1450

1 Radial insert ball bearings **1452**

- 1.1 Bearing design 1452
- 1.2 Load carrying capacity 1470
- 1.3 Compensation of angular misalignments 1471
- 1.4 Lubrication 1473
- 1.5 Sealing 1474
- 1.6 Speeds 1476
- 1.7 Noise 1477
- 1.8 Temperature range 1478
- 1.9 Cages 1478
- 1.10 Internal clearance 1480



1.11	Dimensions, tolerances	1483		
1.12	Suffixes	1485		
1.13	Structure of bearing designation	1486		
1.14	Dimensioning	1488		
1.15	Minimum load	1491		
1.16	Design of bearing arrangements	1491		
1.17	Mounting and dismounting	1504		
1.18	Legal notice regarding data freshness	1505		
1.19	Further information	1506		
	Product tables	1508		
	 Radial insert ball bearings with eccentric locking collar	1508		
	Radial insert ball bearings with grub screws in inner ring	1520		
	Inch size radial insert ball bearings	1524		
	Radial insert ball bearings with adapter sleeve	1532		
	Radial insert ball bearings with drive slot	1534		
	Product tables	1536		
	 Self-aligning deep groove ball bearings, bore for fit	1536		
	Self-aligning deep groove ball bearings, square bore	1540		
	Self-aligning deep groove ball bearings, hexagonal bore	1542		
	Radial insert ball bearings with rubber interliner	1546		
	Radial insert ball bearings with steel aligning ring	1548		
	Corrosion-resistant radial insert ball bearings, VA design	1550		
	Corrosion-resistant radial insert ball bearings, with Corrotect coating	1556		
	Black Series, radial insert ball bearings in accordance with JIS	1558		





Matrix for bearing preselection

The matrix gives an overview of the types and design features of radial insert ball bearings.

It can be used to make a preliminary assessment of whether a bearing is fundamentally suitable for the envisaged application.

The additional information provided in the product chapter (see column "detailed information") and in the Technical principles must, however, be observed in addition to this overview in selection of the bearing.

Design features and suitability			Radial insert ball bearings (ISO range)			
+++ extremely suitable ++ highly suitable + suitable (+) suitable with restrictions - not suitable/not applicable ✓ available			with eccentric locking collar	with grub screws	with adapter sleeve	detailed information
						1452
Load carrying capacity	radial		+++	+++	+++	1470 1.2
	axial, one direction		+	+	+	1470 1.2
	axial, both directions		+	+	+	1470 1.2
	bending and torsional moments		++	++	++	1470 1.2
Compensation of angular misalignments	static		+++	+++	+++	1471 1.3
	dynamic		-	-	-	1471 1.3
Bearing design	cylindrical bore		✓	✓	✓	1452 1.1
	tapered bore		-	-	-	
	separable		-	-	-	
Lubrication	greased		✓	✓	✓	1473 1.4
Sealing	open		-	-	-	
	non-contact		✓	✓	-	1474 1.5
	contact		✓	✓	✓	1474 1.5
Operating temperature in °C ¹⁾²⁾³⁾	from to		-20 +100	-20 +100	-20 +100	1478 1.8
Suitability for	high speeds		++	++	+++	1476 1.6
	high running accuracy		(+)	(+)	++	1483 1.11 114
	low-noise running		+	+	++	1477 1.7 1452 1.1
	high rigidity		+	+	+	54
	reduced friction		(+)	(+)	(+)	56
	length compensation within bearing		-	-	-	
	non-locating bearing arrangement		-	-	-	
	locating bearing arrangement		++	++	++	
X-life bearings			✓	✓	✓	1453
Bearing bore d in mm	from to		12 120	12 90	20 50	1508
Product tables	from page		1508	1520	1532	

1) Temporary temperature peaks are possible up to +120 °C (not in the case of bearings with rubber interliner)

2) High and low temperature designs available from -40 °C to +180 °C

3) High temperature design available from +150 °C to +250 °C



	Radial insert ball bearings (ISO range)						Black Series (JIS range)		
	with drive slot	with fit	with square bore	with hexagonal bore	with rubber interliner	with steel aligning ring	with grub screws	with adapter sleeve	detailed information
									1452
	+++	+++	+++	+++	+++	+++	+++	+++	1470 1.2
	+	+	-	-	+	+	+	+	1470 1.2
	+	+	-	-	+	+	+	+	1470 1.2
	++	+	+++	+++	++	++	++	++	1470 1.2
	+++	+++	+++	+++	+++	+++	+++	+++	1471 1.3
	-	-	-	-	-	-	-	-	1471 1.3
	✓	✓	-	-	✓	✓	✓	✓	1452 1.1
	-	-	-	-	-	-	-	-	
	✓	✓	✓	✓	✓	✓	✓	✓	1473 1.4
	-	-	-	-	-	-	-	-	
	✓	-	-	-	-	-	-	-	1474 1.5
	✓	✓	✓	✓	✓	✓	✓	✓	1474 1.5
	-20 +100	-20 +100	-20 +100	-20 +100	-20 +85	-20 +100	-20 +100	-20 +100	1478 1.8
	(+)	+++	-	-	+	++	++	+++	1476 1.6
	(+)	+++	-	-	(+)	(+)	(+)	++	1483 1.11 114
	+	+	-	-	+++	+	+	++	1477 1.7 1452 1.1
	+	+	+	+	(+)	+	+	+	54
	(+)	(+)	(+)	(+)	(+)	(+)	(+)	(+)	56
	-	-	-	-	-	-	-	-	
	+++	-	+++	+++	-	-	-	-	139
	-	++	-	-	++	++	++	++	139
	✓	✓	-	-	✓	✓	-	-	1453
	20 70	12 60	16,3 39,7	16,1 38,1	12 50	20 40	12 90	12 80	1508
	1534	1536	1540	1542	1546	1548	1558	1564	



1 Radial insert ball bearings



Radial insert ball bearings are ready-to-fit machine elements. In combination with drawn shafts, they are particularly easy to fit and suitable for the design of economical bearing arrangements. They are highly suitable where predominantly radial loads must be supported. Radial insert ball bearings with an extended inner ring undergo less tilting and therefore run more smoothly.

Radial insert ball bearings with a spherical outer ring are highly suitable where:

- static angular misalignments of the shaft must be compensated, which are caused by mounting inaccuracies and tolerances in the adjacent construction ▶ 1471 | 1.3
- very good seals are required in environmental conditions such as dust, contamination, moisture, stone impacts and shocks ▶ 1474 | 1.5.

Radial insert ball bearings with a cylindrical outer ring are highly suitable where:

- a cylindrical housing bore is already present
- the outer ring of the bearings is to be located by means of easy-to-fit snap rings.

Radial insert ball bearings with a profiled bore are highly suitable where:

- shafts must transmit very high torques.

Radial insert ball bearings with a rubber interliner are highly suitable where:

- vibrations and shocks must be supported
- damping of running noise is required.

1
Compensation of static angular misalignments, available seals with sealing action of different magnitudes

η = sealing action

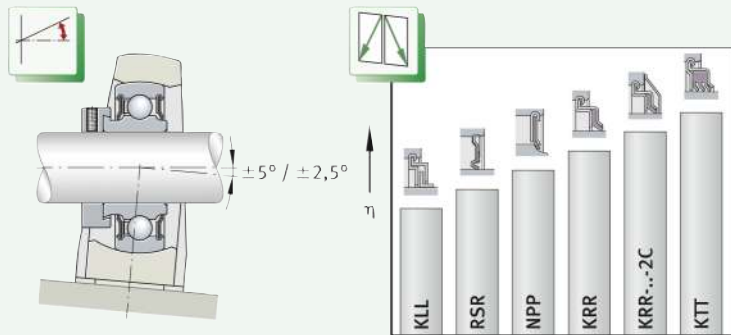

1.1 Bearing design

Design variants

The radial insert ball bearings have a spherical or cylindrical outside surface. They are predominantly located on the shaft by means of an eccentric locking collar or grub screws.

The bearings are sealed using a range of available standard seals that are matched to the different application conditions.

Radial insert ball bearings are available in the following designs:

- standard bearings in accordance with ISO ►1453
- corrosion-resistant bearings in a VA design or with a Corrotect coating in accordance with ISO ►1461
- Black Series with Durotect BS coating in accordance with JIS B 1558 ►1464.



Radial insert ball bearings are also available in many other designs and sizes, as well as for specific applications, by agreement.

X-life

Numerous sizes are supplied in X-life premium quality. These products are indicated in the product tables.

Radial insert ball bearings of X-life premium quality have, for example, a lower roughness Ra and higher geometrical accuracy of the raceways than comparable designs that are not X-life. As a result, these bearings have higher load carrying capacity and longer rating life although their dimensions are identical. In certain applications, this means that it may be possible to design a smaller bearing arrangement.



Radial insert ball bearings of X-life premium quality have an eccentric locking collar of an improved design and the quantity and distribution of the lubricant has been optimised. Housings ASE have additional cross-pieces on the underside. For extreme requirements, the cage and seal material in the high and low temperature designs (suffix FA101) has been significantly improved in comparison with earlier versions.



 *Metric and inch size designs*

Radial insert ball bearings are available in metric sizes. Some series have a bore diameter with inch dimensions.

Standard bearings in accordance with ISO

The radial insert ball bearings are based on the deep groove ball bearing series 60, 62 and 63. The numerals identify the ball set and therefore the load carrying capacity of the bearing ►1470|1.2. The inner ring is extended on one or both sides, while the bore has a plus tolerance in most of the designs.

Radial insert ball bearings are particularly easy to fit and are preferentially suitable for drawn shafts of tolerance classes h6  to h9 .

For non-locating bearings, shafts of tolerance classes h5  to h7  are recommended.

 *Spherical outside surface for the compensation of misalignments*

Radial insert ball bearings with a spherical outside surface are single row, ready-to-fit units comprising a solid outer ring, cages made from plastic or sheet steel and seals P, R, L or T ►1474| 6. Bearings with an inner ring extended on both sides undergo less tilting of the inner ring and therefore run more smoothly.

In combination with a housing matched to the design, bearings with a spherical outside surface can compensate for misalignment of the shaft ►1471|1.3.

With only a few exceptions, radial insert ball bearings can be relubricated. For this purpose, they have two lubrication holes in one plane of the outer ring offset by 180°.

Location on the shaft is by means of an eccentric locking collar, grub screws in the inner ring, an adapter sleeve, a drive slot, fit or profiled bore ►1454| 2.

 *Cylindrical outside surface for a cylindrical housing bore*

Radial insert ball bearings with a cylindrical outside surface are single row, ready-to-fit units comprising a solid outer ring, an inner ring extended on one or both sides, cages made from plastic and seals P or R ►1474| 6. Bearings with an inner ring extended on both sides undergo less tilting of the inner ring and therefore run more smoothly.

The radial insert ball bearings are greased and cannot be relubricated.

Their location on the shaft is by means of an eccentric locking collar, fit or profiled bore ►1455 and ►1458.



Location and design

Locating bearings

Location is by means of eccentric locking collars, grub screws or integrated adapter sleeves ▶ 1454 | 2 and ▶ 1454 | 3. Certain series can be located by means of a fit on the shaft. The extended inner ring on one or both sides is used as a running surface for the seal and prevents significant tilting of the inner ring.

Bearings with vibration damping

For applications where strong vibrations can occur, damping can be achieved using radial insert ball bearings with a thick-walled rubber interliner ▶ 1454 | 3.

Non-locating bearings

Radial insert ball bearings with a drive slot in the inner ring are non-locating bearings that are used for low speeds and loads in order to compensate for elongations of the shaft ▶ 1454 | 3. The slot allows simple radial location of the bearing on the shaft.



Location methods for radial insert ball bearings

- ① Location using eccentric locking collar, bearing with relubrication facility
- ② Location using integrated adapter sleeve, bearing with relubrication facility
- ③ Location using grub screws in inner ring, bearing with relubrication facility

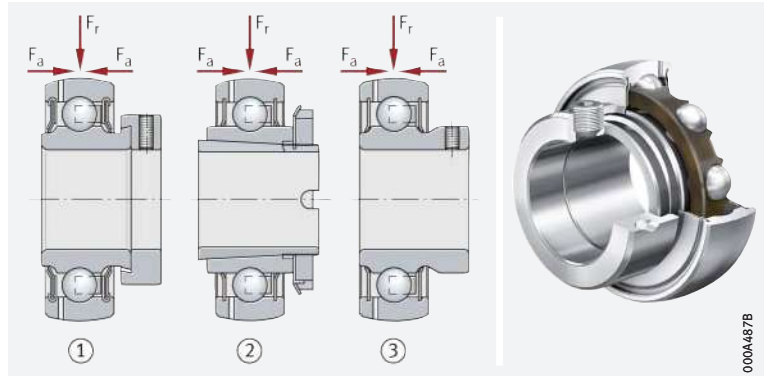

000A487B



Design examples of radial insert ball bearings

- ① Radial insert ball bearing with rubber interliner
- ② Radial insert ball bearing with drive slot (non-locating bearing), with relubrication facility
- ③ Radial insert ball bearing with aligning ring (for cylindrical housing bore)

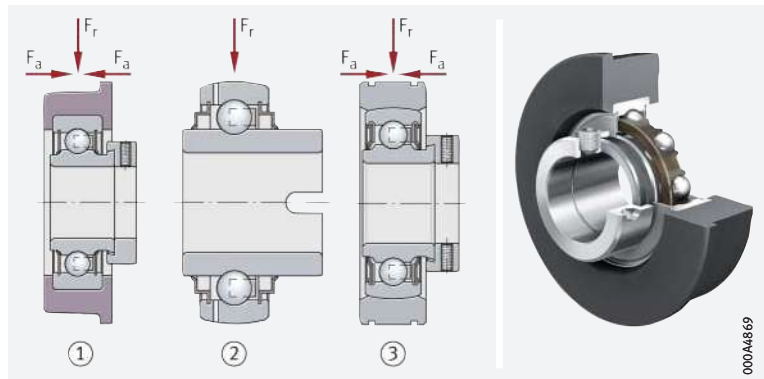

000A4869

Radial insert ball bearings with eccentric locking collar

These "classic" INA radial insert ball bearings are located on the shaft by means of a locking collar ▶ 1455 | 4. They are particularly suitable for bearing arrangements with a constant direction of rotation or, under low speed and load, for an alternating direction of rotation.

The locking collar is preferably tightened in the direction of rotation and secured by means of a grub screw. This location method prevents damage to the shaft and can be easily loosened again.

With the exception of a few series, sealed bearings can be relubricated.

The inner rings up to $d = 60$ mm and the locking collars in general have a Corrotect coating and are thus protected against fretting corrosion. This is not valid for the series RAE..-XL-NPP(-B).

Corrosion protection



Location by means of eccentric locking collar

GE..-XL-KRR-B

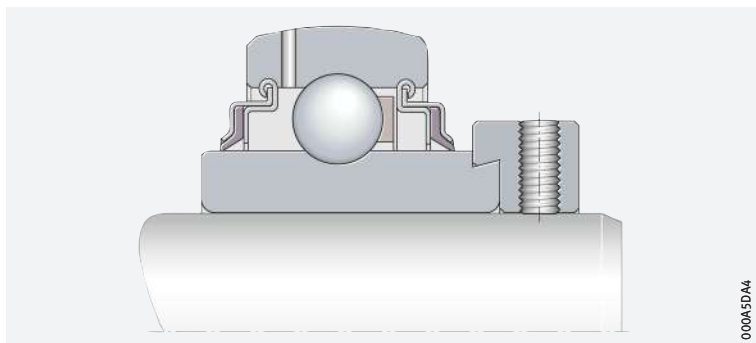

Radial insert ball bearings with eccentric locking collar and slots in the outer ring

The basic design of series RAE..-XL-NPP-NR is a radial insert ball bearing with an eccentric locking collar and an inner ring extended on one side ▶ 1455 | 5.

The outer ring has a cylindrical outside surface and two slots to DIN 616 and ISO 464. The bearings are fitted in cylindrical bores and axially located by easy-to-fit snap rings. The bearing is supplied with one snap ring to DIN 5417 already fitted.

The radial insert ball bearings are greased and cannot be relubricated.

Inner rings up to a bore diameter $d = 60$ mm have a Corrotect coating and are thus protected against fretting corrosion.

Corrosion protection



Radial insert ball bearing with cylindrical outside surface and two slots in outer ring

RAE..-XL-NPP-NR

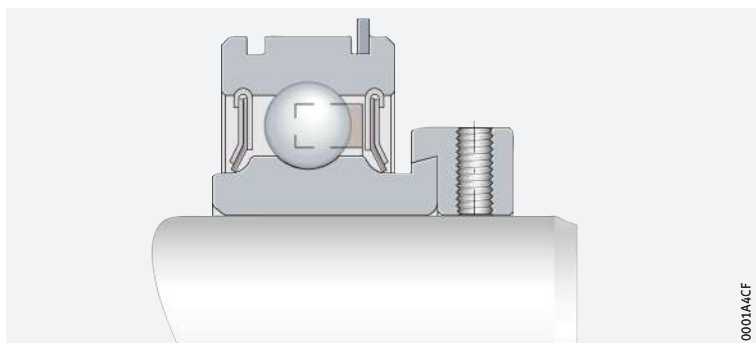

Radial insert ball bearings with grub screws in the inner ring

In the case of these radial insert ball bearings, the inner ring is located on the shaft by means of two grub screws offset by 120° ▶ 1456 | 6. This location method is suitable for bearing arrangements with a constant direction of rotation or, under low speed and load, for an alternating direction of rotation.

The grub screws are self-retaining and have a fine pitch thread with cup point for secure location of the bearings.

With the exception of series AY..-XL-NPP-B, the bearings can be relubricated.

6
Location by means of grub screws
in the inner ring

GYE..-XL-KRR-B

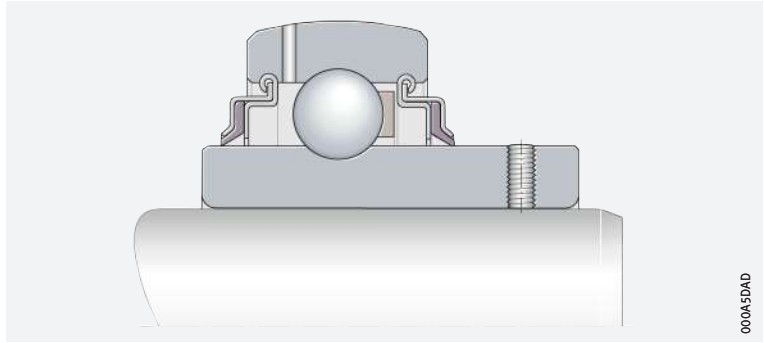

Radial insert ball bearings with adapter sleeve

In the case of this series, the inner ring is located on the shaft by means of an adapter sleeve with a locknut and a tab washer ▶ 1456 | 7. These radial insert ball bearings are suitable for shafts up to tolerance class h11 ⑥.

The bearings can be relubricated.

⑥ Suitable
for very high speeds

This location method is suitable for bearing arrangements with a constant or alternating direction of rotation and for high speeds.

The adapter sleeve and locknut give concentric, force locking location of the bearing inner ring on the shaft. As a result, the speeds that can be achieved are approximately the same as with deep groove ball bearings. These bearings also give quieter running than normal radial insert ball bearings. The adapter sleeve, locknut and tab washer are all zinc-coated.

⑥ Reversing operation

The bearings are highly suitable for reversing operation. As a result of the force locking connection, there is no occurrence of fretting corrosion between the shaft and the bore of the adapter sleeve.

⑥ Interchangeability

Due to the integral adapter sleeve, the bearings have the same radial dimensions as, and slightly lower basic load ratings than, radial insert ball bearings with an eccentric locking collar, or with grub screws in the inner ring, and are interchangeable with these bearings.



7
Location using adapter sleeve and
locknut

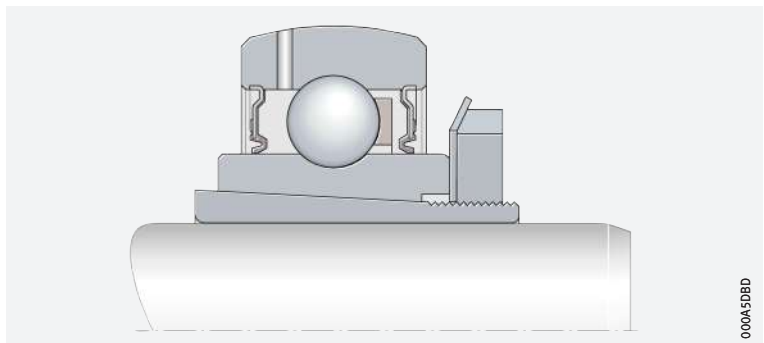

GSH..-XL-2RSR-B



 Suitable as non-locating bearings for low speeds

Radial insert ball bearings with drive slot

Radial insert ball bearings with a drive slot in the inner ring are non-locating bearings with good high temperature characteristics  1457  8. Non-locating bearings are used at low speeds and loads to compensate for elongations of the shaft.

Due to the slot, they are easy to locate in a radial direction. Rotation is prevented by means of a drive pin on the shaft or a set collar with a pin. The non-locating bearings are suitable for drawn shafts of tolerance classes h5  to h7 .

The bearings can be relubricated.

 Corrosion protection

Inner rings up to a bore diameter d = 60 mm have a Corrotect coating and are thus protected against fretting corrosion.





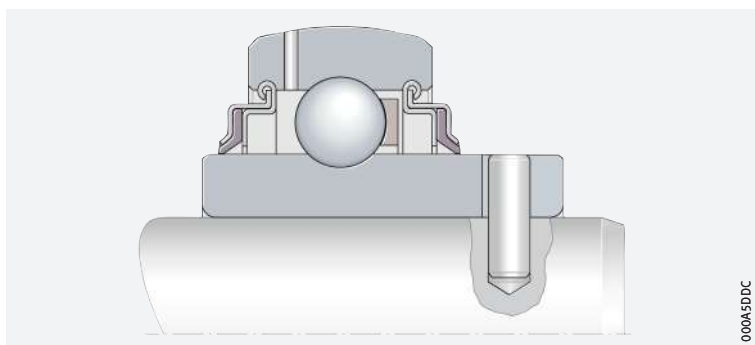

Location by means of drive slot

GLE..-XL-KRR-B



Self-aligning deep groove ball bearings with bore for fit

Self-aligning deep groove ball bearings are available with a cylindrical bore for a fit seat  1457  9 and with a reamed square or hexagonal bore  1458  11.

The outer ring has a spherical outside surface.

Bearings with a fit seat on the shaft can achieve the same speeds as standard ball bearings. These are suitable for bearing arrangements with an alternating direction of rotation and offer smooth running.



Self-aligning deep groove ball bearing with fit seat

2..-XL-NPP-B

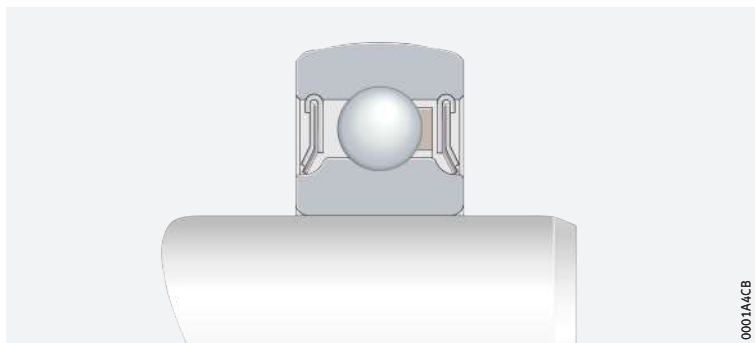

For self-aligning deep groove ball bearings with a fit seat, the fit data for ball bearings apply.



0001A4CB

Deep groove ball bearings with bore for fit

These bearings have a cylindrical outer ring and are fitted in cylindrical bores \blacktriangleright 1458 | \square 10. The inner ring is extended on both sides and is located on the shaft using a fit. Due to the extended inner ring, additional axial spacer rings are not required.

The concentric seat allows speeds equivalent to those of standard ball bearings, while the load can be either constant or alternating. Smooth running is also achieved.

The tolerance of the inner ring bore corresponds to tolerance class Normal in accordance with ISO 492.

The sheet steel washers extended outwards and angled downwards form a large grease reservoir.

\square 10
Deep groove ball bearing
with extended inner ring and
bore for fit

2..-XL-KRR
2..-XL-KRR-AH

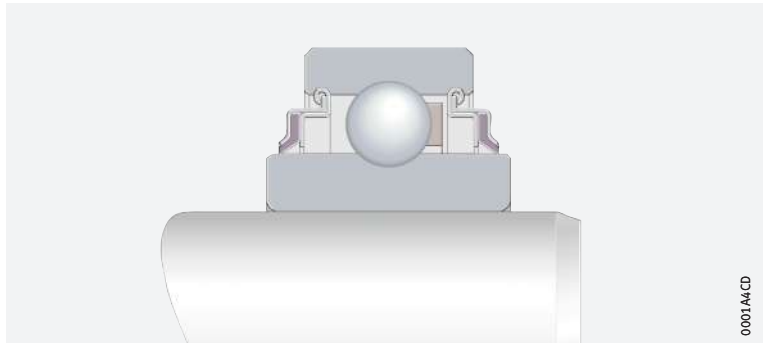

0001A4CD

Transmission
of high torques

Self-aligning deep groove ball bearings with profiled bore

Bearings with a profiled bore are used where shafts must transmit very high torques and this is only possible using square or hexagonal shafts \blacktriangleright 1458 | \square 11. Rotation is prevented by form fit.

These bearings have a spherical or cylindrical outer ring and an inner ring that is extended on both sides \blacktriangleright 1458 | \square 11 and \blacktriangleright 1459 | \square 12. Shafts of tolerance class h11 $\text{\textcircled{C}}$ are recommended.

The bearings are greased to their maximum, some designs with a spherical outside surface can also be relubricated.

The bearings have a Corrotect coating.

$\text{Corrosion protection}$

\square 11
Self-aligning deep groove
ball bearings
with profiled bore

- ① Square bore
- ② Hexagonal bore

VK...KTT-B
SK...KRR-B

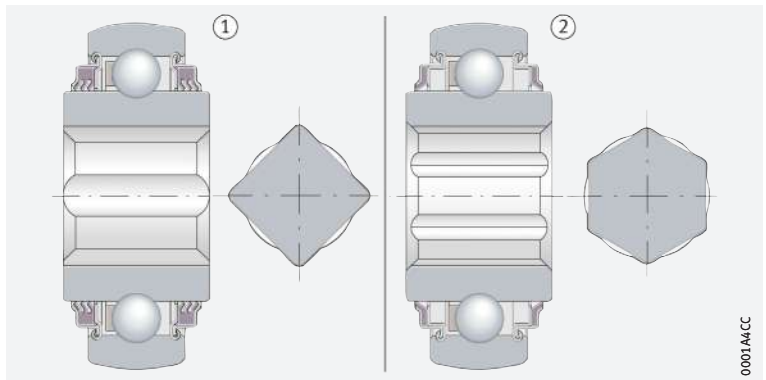

0001A4CC

12

Deep groove ball bearings with extended inner ring and profiled bore

① Hexagonal bore

SK..-KRR
SK..-KTT

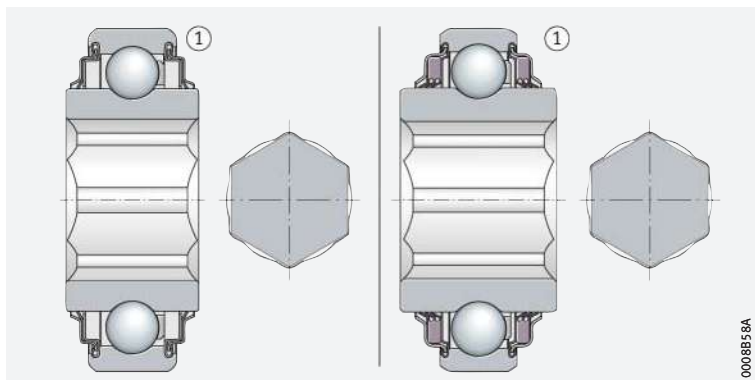

Radial insert ball bearings with rubber interliner

Radial insert ball bearings with a rubber interliner are located on the shaft using an eccentric locking collar. The outer ring is encased in a thick-walled NBR interliner ▶ 1459 | 13.

13

Radial insert ball bearings with rubber interliner

① CRB..-XL with locating shoulder

② RABR(A,B)

③ RCR(A,B)

④ RCSM(A,B)

Structure of bearing designation

▶ 1487 | 19

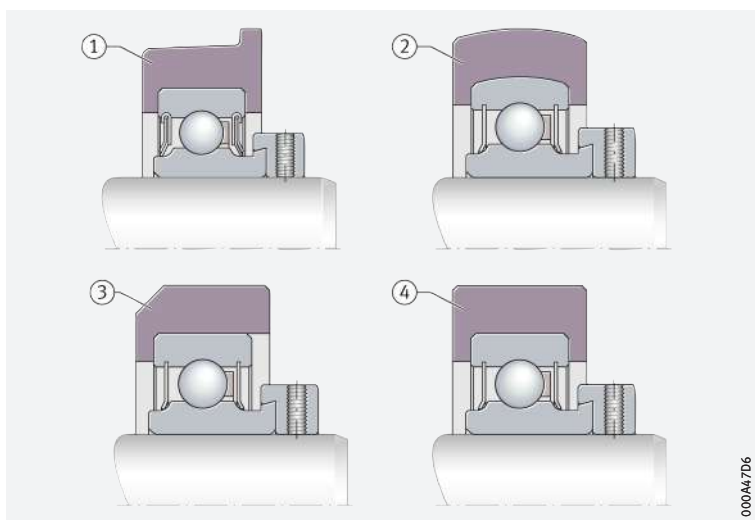

🔊 Damping of running noise

The interliner absorbs vibrations and shocks and thus gives damping of running noises.

🔧 Various types

The interliners have a spherical or cylindrical outside surface. For roll bearing arrangements, one series has a locating shoulder on the rubber interliner.

Bearings with rubber interliners cannot be relubricated.



Note the tube and housing diameters for radial insert ball bearings with rubber interliner:

■ CRB: tube inside diameter $D - 0,6$ to $-1,6$

■ RABR, RCR, RCSM: housing diameter $D - 0,25$ to $-0,35$.

🛡️ Corrosion protection

The inner ring and locking collar have a Corrotect coating and are thus protected against fretting corrosion. This is not valid for series with the radial insert ball bearing RALE..-XL-NPP(-B).

Radial insert ball bearings with steel aligning ring

These bearings are based on radial insert ball bearings with an eccentric locking collar or on self-aligning deep groove ball bearings, but additionally have an axially split outer ring as an aligning ring ▶ 1460 | 14. They are mounted in cylindrical bores and can compensate static misalignments of the shaft up to $\pm 5^\circ$.

In series PE, the inner ring is located on the shaft by means of a locking collar while, in series BE, it is located by a fit.

Radial insert ball bearings with an aligning ring cannot be relubricated.

☞ Suitable for sheet metal constructions

Due to the annular slots in the outer ring to DIN 616, they are highly suitable for sheet metal constructions. In this case, they are axially located using snap rings to DIN 5417.



The fit tolerances of the aligning rings are those of the deep groove ball bearings. Select the fit for the shaft and housing such that the outer ring of the radial insert ball bearing can undergo self-alignment.

☞ Corrosion protection

The aligning ring has a Corrotect coating and is thus protected against fretting corrosion. In the case of series PE...XL, the inner ring and locking collar also have a coating.

14 Radial insert ball bearing with steel aligning ring

PE...XL

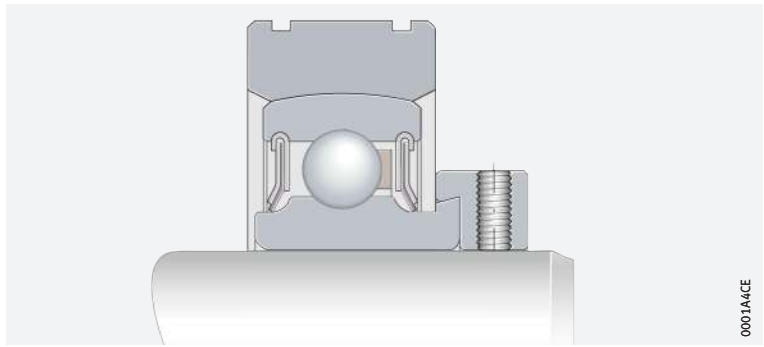

Corrosion-resistant bearings in a VA design or with a Corrotect coating in accordance with ISO

The radial insert ball bearings SUB, SUC and SUG, as well as the radial insert ball bearings with the suffix FA125, are designed for corrosion-resistant bearing arrangements. They are therefore equally suitable for applications involving humidity, contaminated water, salt spray mist and for cleaning agents. Their classic areas of application include the agricultural, construction and mining sector, conveying equipment, textile, paper and woodworking machinery, as well as machinery for the food and drink industry.

Corrosion-resistant VA design or with Corrotect coating

The bearings are available in a corrosion-resistant VA design or with a Corrotect thin film coating ►1461 | 15. They correspond in their design to single row deep groove ball bearings 62, are ready to fit, particularly easy to fit and allow robust, economical bearing arrangements with a long operating life. They are located on the shaft by means of grub screws in the extended inner ring or by means of an eccentric locking collar.

Operation even under difficult conditions is ensured by seals and greases that are matched to the application.

15

Corrosion-resistant radial insert ball bearings, with Corrotect coating or in VA design

- ① SUC (VA design)
- ② SUG (VA design)
- ③ GRAE..-NPP-B-FA125 (with Corrotect coating)

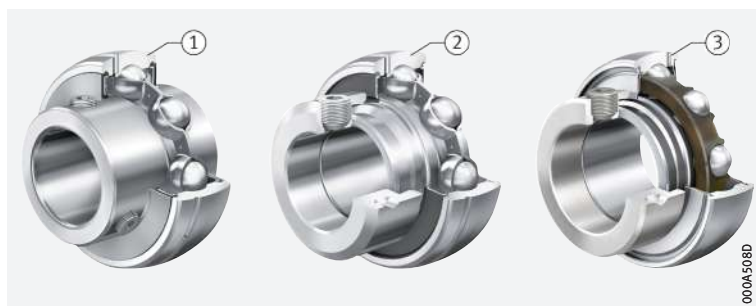

Radial insert ball bearings in corrosion-resistant VA design

In the case of radial insert ball bearings SUB, SUC and SUG, the bearing rings, eccentric locking collar and rolling elements are made from high alloy, corrosion-resistant rolling bearing steel with an increased chromium and molybdenum content, material number 1.4125.

Sheet steel cages made from corrosion-resistant steel, material number 1.4301, retain and guide the rolling elements.

Location by means of corrosion-resistant VA grub screws

The inner ring is located axially on the shaft by means of two corrosion-resistant VA grub screws, material number 1.4301, offset by 120°.

This location method is suitable for bearing arrangements with a constant direction of rotation or, under low speed and load, for an alternating direction of rotation.

The grub screws are self-retaining and have a fine pitch thread with cup point for secure location of the bearings when taking account of the stated tightening torques ►1504 | 30.

Location using corrosion-resistant VA eccentric locking collar

The bearings are located on the shaft by means of a corrosion-resistant VA locking collar. They are thus particularly suitable for bearing arrangements with a constant direction of rotation or, under low speed and load, for an alternating direction of rotation.

The locking collar is preferably tightened in the direction of rotation and must be secured by means of a grub screw. This location method prevents damage to the shaft and can be easily loosened again.



 **Media resistance**

In the food industry in particular, the resistance of the material in relation to various cleaning agents is of increasing importance ► 1462 |  1.

 **1**
Resistance to media

Medium + resistant (+) moderately resistant (-) barely resistant - not resistant	Concentration %	X5CrNi18-10 (1.4301)		440C (1.4125)	
		+20 °C	+80 °C	+20 °C	+80 °C
Hydrochloric acid HCl	0,1	+	+	-	-
	1	(+)	-	-	-
	18	-	-	-	-
Hydrofluoric acid HF	1	-	-	-	-
	5	- ¹⁾	-	- ¹⁾	-
Sulphuric acid H ₂ SO ₄	1	+	-	-	-
	10	(+)	-	-	-
	96	+	(+)	-	-
Sulphurous acid H ₂ SO ₃	1	+	+	-	-
Nitric acid HNO ₃	5	+	+	-	-
	25	+	+	+	(+)
	65	+	+	+	(+)
Phosphoric acid H ₃ PO ₄	1	+	+	+	+
	10	+	+	(+)	+
	85	+	+	+	-
Formic acid HCOOH	5	+	+	-	-
	25	+	+	-	-
Acetic acid CH ₃ COOH	5	+	+	+	-
	25	+	+	+	-
Citric acid	5	+	+	+	+
	25	+	+	-	-
Chloroacetic acid	5	+	+	(+)	-
Sodium chloride NaCl	10	+	+	(-)	(-)
Sea water	4	+	+	(-)	(-)
Distilled water	-	+	+	+	+
Ammonium hydroxide NH ₄ OH	1	+	+	+	+
	10	+	+	+	+
Potassium hydroxide solution KOH	0,1	+	+	+	+
	1	+	+	+	+
	10	+	+	+	+
Sodium hypochlorite solution	1	+ ¹⁾	+	2)	(-)
Hydrogen peroxide H ₂ O ₂	5	+	+	+	+

¹⁾ Not tested.
Estimate generated from remaining test series.

²⁾ Not tested.
No estimate possible.

 **Anti-corrosion coating system Corrotect**

Radial insert ball bearings with Corrotect coating

The radial insert ball bearings GRAE...XL-NPP-B-FA125 and GE...XL-KRR-B-FA125 have a Corrotect thin film coating on all surfaces. Plastic cages made from polyamide PA66 retain and guide the rolling elements.

The Corrotect thin film coating technology is an economical alternative to radial insert ball bearings with conventional corrosion protection. The thickness of the coating film is between 2 µm and 5 µm.

The advantages of the Corrotect thin film coating are:

- All surfaces are protected against corrosion, including the turned surfaces of chamfers and radii
- Rust beneath seals is prevented in the long term
- Smaller spots that are damaged by the application and are bright as a result remain protected against corrosion by the cathodic protection effect
- Operating life is significantly longer compared to uncoated parts due to the corrosion protection
- Uncoated bearings and housings are fully interchangeable with the coated versions of the same design
- Bearings and housings made from corrosion-resistant rolling bearing steel are often no longer required.



The use of the Corrotect thin film coating is not permitted for direct contact with foodstuffs.

 **Media resistance**

The resistance of the Corrotect thin film coating to various media must be taken into consideration ► 1463 |  2.

 2
Resistance to media

Chemicals	Corrotect coating ¹⁾
Neutral, organic fluids (oil, brake fluid, petrol)	Resistant
Aqueous salt solutions in the neutral range $6 \leq \text{pH} \leq 8$ (table salt NaCl, seawater applications)	Conditionally resistant
Acidic liquids (pH ≤ 6)	Not resistant
Alkaline liquids (pH ≥ 8)	Not resistant
Oxidising substances (ozone, chlorine, peroxides, hypochlorides)	Not resistant

¹⁾ Valid for Corrotect coatings based on zinc and zinc alloy.

 **Location by means of locking collar**

The bearings are located on the shaft by a locking collar. They are thus particularly suitable for bearing arrangements with a constant direction of rotation or, under low speed and load, for an alternating direction of rotation.

The locking collar is preferably tightened in the direction of rotation and must be secured by means of a grub screw. This location method prevents damage to the shaft and can be easily loosened again.



Black Series in accordance with JIS B 1558

FAG radial insert ball bearings with a spherical outer ring are based on single row deep groove ball bearings 62 and are designed in accordance with JIS B 1558. The Black Series radial insert ball bearings are available with two location methods and one type of seal. They can be relubricated and are particularly easy to install.

The radial insert ball bearings are pregreased and can be relubricated by means of two lubrication holes in the outer ring.

☞ *Cages made from plastic*

The bearings have plastic cages ▶ 1479 and are sealed on both sides by single piece seals RSR with a vulcanised seal lip and an outer flinger shield.

☞ *Quiet running, low frictional torque*

The honed raceways of the bearing rings, in conjunction with the high ball grade, ensure quiet running and a reduced frictional torque.

☞ *Basic corrosion protection Durotect BS*

The inner and outer rings as well as the flinger shields are provided with the black Durotect BS coating in order to offer basic protection against corrosion.

Adapter sleeves have a Durotect BS or phosphate coating.

Location on shaft

☞ *Location by means of grub screws of grub screws*

In the radial insert ball bearings UC, the inner ring is located on the shaft by means of two grub screws offset by 120° ▶ 1464 | ☞ 16. They are suitable for bearing arrangements with a constant direction of rotation or, under low speed and load, for an alternating direction of rotation.

The grub screws are self-retaining and have a fine pitch thread with cup point for secure location of the bearings. In order to allow better differentiation, the metric grub screws have a Durotect BS coating while the inch size grub screws are zinc-coated.

☞ 16
Location by means of grub screws in the inner ring

UC

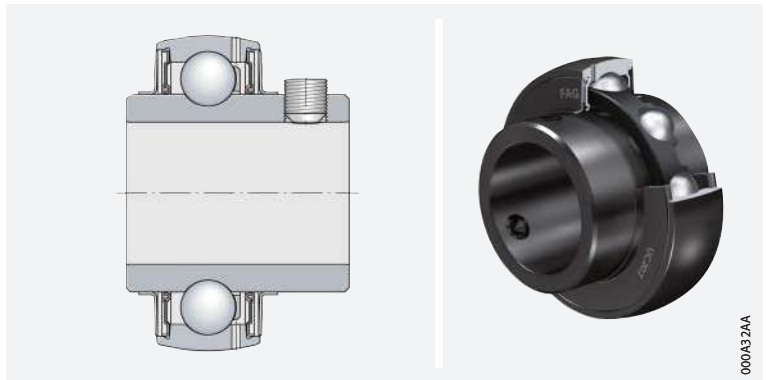

☞ *Location by means of adapter sleeve*



In the radial insert ball bearings UK, the inner ring is located on the shaft by means of a concentric adapter sleeve in accordance with JIS B 1552 ▶ 1464 | ☞ 17. The inner and outer roughness of the adapter sleeve is Ra 2,5. They are suitable for bearing arrangements with an alternating direction of rotation, even under high speed and load.

☞ 17
Location by adapter sleeve

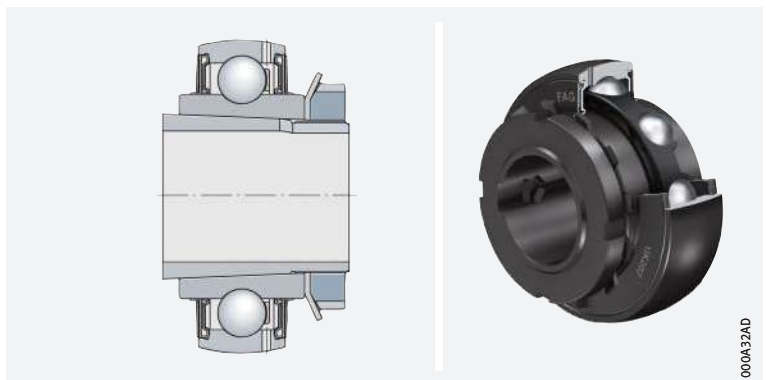
UK



Comparison of radial insert ball bearing series

The possible dimensions and features of the standard bearings are presented in the following table ▶ 1466 |  3. The corrosion-resistant radial insert ball bearing range and the radial insert ball bearings in accordance with JIS (Black Series) are summarised separately ▶ 1468 |  4.



 **3**
Features of radial insert
ball bearings, comparison of
standard bearing series

Series	Shaft diameter				Location
	mm		inch		
	from	to	from	to	
GE..-XL-KLL-B	20	50	–	–	Eccentric locking collar
E..-XL-KLL	20	50	–	–	Eccentric locking collar
GRAE..-XL-NPP-B	12	60	–	–	Eccentric locking collar
GRA..-NPP-B-AS2/V	–	–	5/8	1 ¹⁵ /16	
RABRB..-XL-FA106	12	50	–	–	Eccentric locking collar
RABRA..-XL-FA106	30	–	–	–	
RAE..-XL-NPP-B	12	50	–	–	Eccentric locking collar
RA..-NPP-B	–	–	3/4	1 ¹ /2	
RALE..-XL-NPP-B	20	30	–	–	
PE..-XL	20	40	–	–	
RCSMB..-XL-FA106	15	25	–	–	Eccentric locking collar
RCSMA..-XL-FA106	30	–	–	–	
RCRA..-XL-FA106	20	–	–	–	
RCRB..-XL-FA106	20	–	–	–	
CRB..-XL	20	35	–	–	
RAE..-XL-NPP	12	60	–	–	Eccentric locking collar
RALE..-XL-NPP	20	30	–	–	
RAE..-XL-NPP-NR	20	40	–	–	
RA..-NPP	–	–	5/8	1 ¹ /2	
RAL..-NPP	–	–	3/4	–	
GE..-XL-KRR-B	17	120	–	–	Eccentric locking collar
G..-KRR-B-AS2/V	–	–	1 ⁵ /16	2 ¹⁵ /16	Eccentric locking collar
GE..-XL-KRR-B-2C	25	40	–	–	
GNE..-XL-KRR-B	30	100	–	–	
E..-XL-KRR-B	25	40	–	–	Eccentric locking collar
NE..-XL-KRR-B	50	–	–	–	
GE..-XL-KRR-B-FA101	20	75	–	–	Eccentric locking collar
GE..-XL-KRR-B-FA164	20	90	–	–	
E..-XL-KRR	20	70	–	–	Eccentric locking collar
GE..-XL-KTT-B	20	80	–	–	Eccentric locking collar
GAY..-XL-NPP-B	12	60	–	–	Grub screws
GAY..-NPP-B-AS2/V	–	–	5/8	1 ⁷ /16	
GYE..-XL-KRR-B	12	90	–	–	
GY..-KRR-B-AS2/V	–	–	1/2	2 ¹⁵ /16	
AY..-XL-NPP-B	12	30	–	–	Grub screws
GAY..-XL-NPP-B-FA164	12	15	–	–	Grub screws
GLE..-XL-KRR-B	20	70	–	–	Drive slot
BE..-XL	20	40	–	–	Fit
2..-XL-NPP-B	12	50	–	–	Fit
2..-XL-KRR(-AH)	13	60	–	–	
SK(E)..-KRR-B	16,1	38,1	–	–	Hexagonal bore
SK..-KRR	–	–	7/8	1 ¹ /4	
SK..-KTT-B	–	–	7/8	1 ¹ /4	Hexagonal bore
SK..-KTT	–	–	1 ¹ /4	1 ³ /4	
GSH..-XL-2RSR-B³⁾	20	50	–	–	Adapter sleeve
GVK(E)..-KRR-B-AS2/V	16,3	–	–	–	Square bore
VK(E)..-KTT-B	25,4	38	1	–	
GVK(E)..-KTT-B(-AS2/V)	25,4	39,7	1	1 ⁹ /16	

¹⁾ Recommended application temperature.
If temperatures exceed +100 °C, relubrication must be carried out regularly.

²⁾ Temporary temperature peaks are possible up to 120 °C.

³⁾ Pay attention to the interchangeability of the bearing ► 1456

Accessories	Seal	Compensation of misalignment	Internal clearance Group	Cage	Grease	Relubrication facility	Temperature ¹⁾		Comments	Product table
							°C			
							from	to		Page
–	L	yes	5	Steel	L069	yes	–40	+180	–	► 1508
–	L	no	3	PA66	GA13	no	–20	+100 ²⁾	–	► 1516
–	P	yes	3	PA66	GA13	yes	–20	+100 ²⁾	–	► 1508
–									► 1524	
Rubber interliner	P	yes	3	PA66	GA13	no	–20	+85	–	► 1546
–									Light series	► 1546
–	P	yes	3	PA66	GA13	no	–20	+100 ²⁾	–	► 1508
–									–	► 1524
–									Light series	► 1508
Aligning ring									Annular slots in aligning ring	► 1548
Rubber interliner	P	no	3	PA66	GA13	no	–20	+85	–	► 1546
–									Light series	► 1546
–									Light series, mounting chamfer	► 1546
–									Mounting chamfer	► 1546
–									Abutment shoulder	► 1546
–	P	no	3	PA66	GA13	no	–20	+100 ²⁾	–	► 1516
–									–	► 1516
–									Two slots, one snap ring	► 1516
–									–	► 1530
–									–	► 1530
–	R	yes	3	PA66	GA13	yes	–20	+100 ²⁾	–	► 1508
–	R	yes	3	PA66	GA13	yes	–20	+100 ²⁾	–	► 1524
–									Flinger shields	► 1508
–									Heavy series	► 1510
–	R	yes	3	PA66	GA13	no	–20	+100 ²⁾	–	► 1508
–									Heavy series	► 1512
–	R	yes	5	Steel	L069	yes	–40	+180	PTFE seal lip	► 1508
–					GA11					+150
–	R	no	3	PA66	GA13	no	–20	+100 ²⁾	–	► 1516
–	T	yes	3	PA66	GA13	yes	–20	+100 ²⁾	–	► 1508
–	P	yes	3	PA66	GA13	yes	–20	+100 ²⁾	–	► 1520
–									–	► 1524
–									–	► 1520
–									–	► 1524
–	P	yes	3	PA66	GA13	no	–20	+100 ²⁾	–	► 1520
–	P	yes	5	Steel	GA11	yes	+150	+250	PTFE seal lip	► 1520
–	R	yes	5	Steel	L069	yes	–40	+180	PTFE seal lip	► 1534
Aligning ring	P	yes	N	PA66	GA13	no	–20	+100 ²⁾	Annular slots in aligning ring	► 1548
–	R	yes	N	PA66	GA13	no	–20	+100 ²⁾	–	► 1536
–		no								► 1538
–	R	yes	3	PA66	GA13	no	–20	+100 ²⁾	Corrosion-resistant, maximum greasing	► 1542
–		no								► 1544
–	T	yes	3	PA66	L402	no	–20	+100 ²⁾	Corrosion-resistant, maximum greasing	► 1542
–		no			GA13					► 1544
–	RSR	yes	4	PA66	GA13	yes	–20	+100 ²⁾	–	► 1532
–	R	yes	3	PA66	GA13	yes	–20	+100 ²⁾	Corrosion-resistant, maximum greasing	► 1540
–						no				► 1540
–						yes				► 1540



 **4**
Features of radial insert
ball bearings, comparison of
series, corrosion-resistant and
Black Series

Series	Shaft diameter				Location
	mm		inch		
	from	to	from	to	
Corrosion-resistant product range					
GRAE..-XL-NPP-B-FA125	20	60	–	–	Eccentric locking collar
GE..-XL-KRR-B-FA125	20	50	–	–	Eccentric locking collar
SUB	20	50	–	–	Grub screws
SUC	12	50	–	–	Grub screws
SUG	20	50	–	–	Eccentric locking collar
Black Series (radial insert ball bearings in accordance with JIS)					
UC	12	90	$\frac{1}{2}$	$3\frac{1}{2}$	Grub screws
UK	20	80	–	–	Adapter sleeve to JIS B 1552

- 1) Recommended application temperature.
If temperatures exceed +100 °C, relubrication must be carried out regularly.
- 2) Temporary temperature peaks are possible up to 120 °C.

Seal	Compensation of misalignment	Internal clearance	Cage	Grease	Relubrication facility	Temperature ¹⁾ °C		Comments	Product table
						from	to		Page
P	yes	Group 3	PA66	GA47	yes	-20	+100 ²⁾	Corrosion-resistant, Corrotect coating	► 1556
R	yes	Group 3	PA66	GA47	yes	-20	+100 ²⁾	Corrosion-resistant, Corrotect coating	► 1556
RSR	yes	Group 3	Corrosion-resistant VA steel	FM222	yes	-35	+100	Corrosion-resistant, VA design	► 1550
RSR	yes	Group 3	Corrosion-resistant VA steel	FM222	yes	-35	+100	Corrosion-resistant, VA design, with flinger shield	► 1552
RSR	yes	Group 3	Corrosion-resistant VA steel	FM222	yes	-35	+100	Corrosion-resistant, VA design	► 1554
RSR	yes	C3	PA66	GA13	yes	-20	+100 ²⁾	Black Series, Durotect BS coating, basic corrosion protection	► 1558
RSR	yes	C4	PA66	GA13	yes	-20	+100 ²⁾	Black Series, Durotect BS coating, basic corrosion protection	► 1564



1.2 Load carrying capacity

☞ *Suitable for very high radial loads*

☞ *Larger ball sets permit higher loads*

Radial load carrying capacity

The balls are in contact with the raceways at one point only. Under purely radial load, the contact points between the rolling elements and raceways lie at the centre of the raceway. As a result, the connection between the contact points passes through the radial plane, i.e. the optimum load direction is a purely radial load ▶ 1454 | ☞ 2 and ▶ 1454 | ☞ 3. Radial insert ball bearings can therefore support very high radial loads.

The load carrying capacity is dependent on the bearing series and the size of the ball set in the reference bearings. As a result, the deep groove ball bearing series 60 with a smaller bearing cross-section cannot support loads as high as those with the standard series 62 of the same dimensions (relative to the bore diameter d) with a larger ball set. The heavy bearing series 63 with the largest ball set is suitable for even higher loads when used for the same bore diameter ▶ 1470 | ☞ 18.

☞ 18
Reference bearings,
comparison of cross-section and
load carrying capacity
for bearings with $d = 40 \text{ mm}$

C_r = basic dynamic load rating

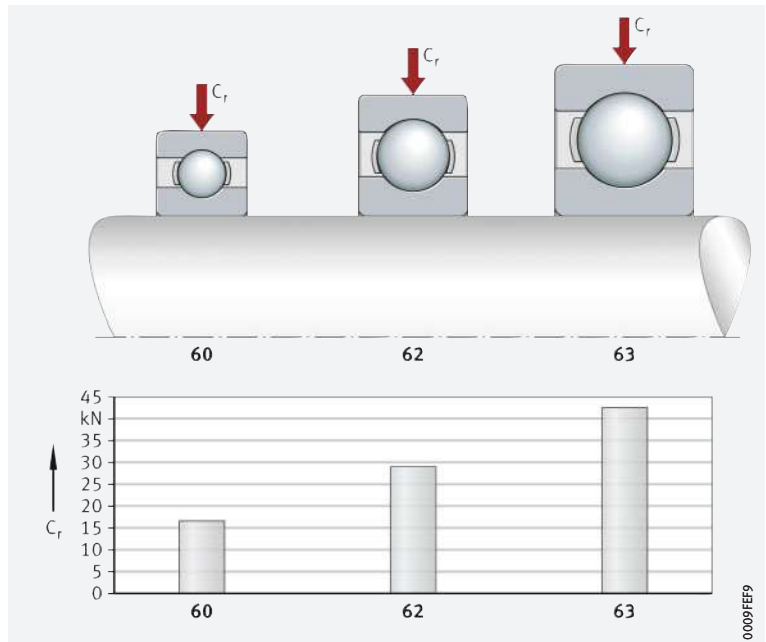

☞ *Capable of supporting axial loads in both directions*

Axial load carrying capacity

Due to the deep raceway grooves in the bearing rings and the narrow osculation between the raceway grooves and balls, radial insert ball bearings can support axial loads in both directions ▶ 1454 | ☞ 2 and ▶ 1454 | ☞ 3. The axial load carrying capacity is dependent, for example, on the bearing size, the internal construction and the operating clearance. If the axial load is too high, however, this can increase the running noise and considerably reduce the operating life of the bearings.



If there is any uncertainty regarding the axial load carrying capacity of the bearings, please consult Schaeffler.

1.3 Compensation of angular misalignments



The units must not be used to support swivelling or tumbling motion
 ► 1472.

Compensation of static misalignments

Bearings with a spherical outer ring outside surface, fitted in housings with a concave bore, can compensate for static misalignment of the shaft ► 1471| 19, ► 1471| 20 and ► 1471| 21.

The compensation of misalignments must be within the permissible angle of $\pm 5^\circ$ for maintenance-free housing units or $\pm 2,5^\circ$ for housing units with a relubrication facility. The precondition is that the centre axes of the inner rings must lie on a common straight line.

For units with a lubrication groove in the housing and lubrication hole in the radial insert ball bearing, the following applies:

- Up to $\pm 2,5^\circ$, the units can be relubricated.
- Between $\pm 2,5^\circ$ and $\pm 5^\circ$, the possibility of relubrication is dependent on the specific unit. Please contact us in this case.
- Over $\pm 5^\circ$, relubrication is no longer possible.



19 Compensation of static housing misalignment

$\pm 5^\circ$ for maintenance-free bearings
 $\pm 2,5^\circ$ for bearings with relubrication facility

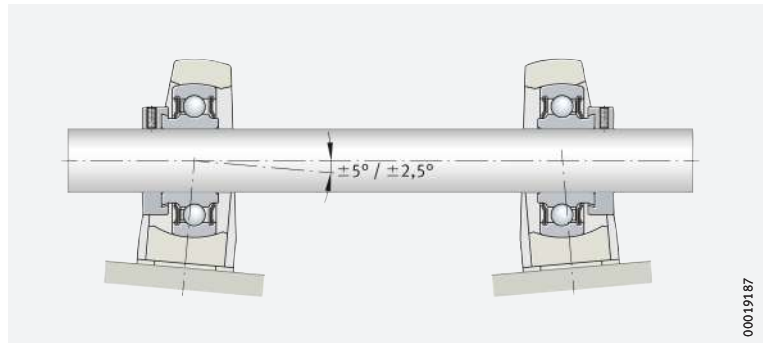

00019187



20 Compensation of static shaft misalignment

$\pm 5^\circ$ for maintenance-free bearings
 $\pm 2,5^\circ$ for bearings with relubrication facility

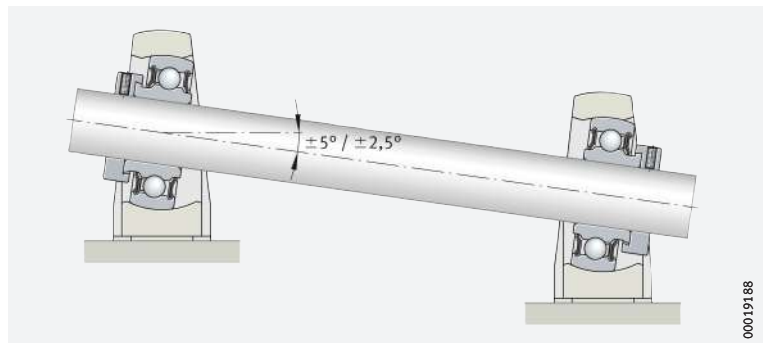

00019188



21 Compensation of static shaft misalignment

$\pm 5^\circ$ for maintenance-free bearings

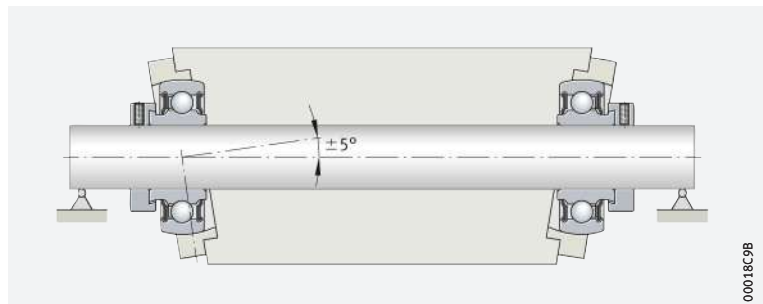

00018C98

Radial insert ball bearings are not suitable for continuous oscillating motion of the outer ring in the housing bore



Radial insert ball bearings cannot be used if the outer ring undergoes continuous oscillating motions in the housing bore. This is the case if the shaft has an excessively large undersize or the centre axes of the inner rings deviate so much from a common straight line that the tilting clearance present in the bearing is exceeded. In this case, the outer ring is included in the oscillating motion of the bearing occurring with each revolution by the ball set of the inner ring. This situation is shown in the figures for a bent shaft and a roller with journals that are parallel but not in alignment ▶ 1472 | 22 and ▶ 1472 | 23. This geometrical defect of the machine parts causes tilting of the bearing during mounting and continuous oscillating motion of the outer ring during rotation.

22
Oscillating motion of outer rings
with a bent shaft

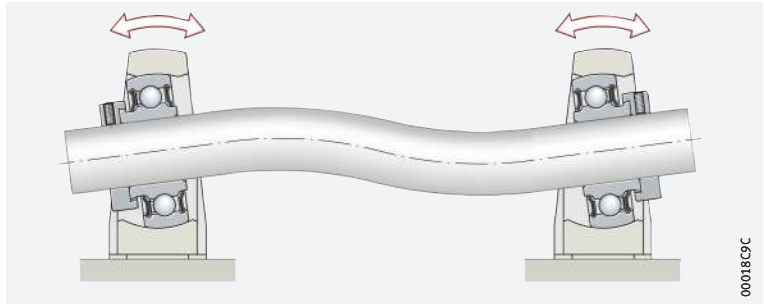

23
Oscillating motion of outer rings
with non-aligned journal

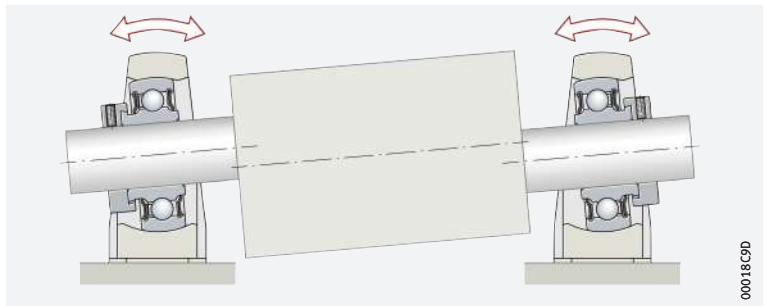

An underdimensioned shaft will cause continuous tumbling motions

A critical situation also arises with a bearing arrangement of an underdimensioned shaft ▶ 1472 | 24. While it is still aligned when free from load, it bends under load as shown by the example of a return roller. As a result, the bearings undergo continuous tumbling motion. If circumferential load is still present on the outer ring in this case, the deflection of the housing bore is accelerated (leading to wear).

24
Oscillating motion of outer rings
with a deflected shaft

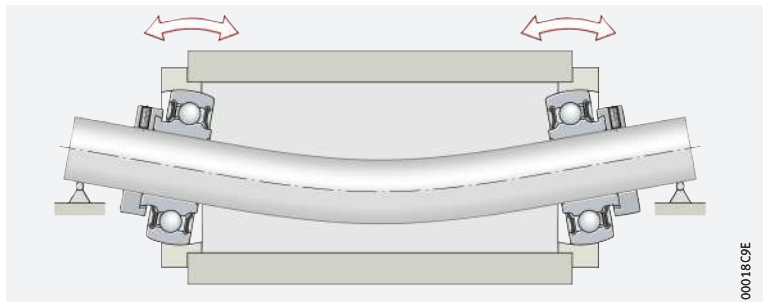

1.4 Lubrication

Radial insert ball bearings sealed on both sides are lubricated with a high quality lithium soap grease with a mineral oil base, which has good anti-corrosion characteristics ► 1473 | 5. Bearings with a spherical outside surface can be relubricated, with the exception of a few series (such as AY..-XL-NPP-B).

Radial insert ball bearings with a cylindrical outside surface have the maximum grease filling. The grease filling is measured so that it is sufficient for the entire life of the bearing. As a result, these bearings are generally maintenance-free. Radial insert ball bearings can have sheet steel washers extended outwards and angled downwards, forming a larger grease chamber. Only a few designs with a cylindrical outside surface can be additionally relubricated.

Radial insert ball bearings with a rubber interliner or aligning ring cannot be relubricated.

 **5**
Recommended greases
for radial insert ball bearings

Designation	Classification	Type of grease	Recommended Arcanol grease for relubrication
GA13	Standard ball bearing and insert bearing grease for $D > 62$ mm	Lithium soap Mineral oil	MULTI3
GA22	Free-running grease with low frictional torque	Lithium soap Ester oil	–
L069	Radial insert ball bearing grease for wide temperature range	Polycarbamide Ester oil	–
GA11	Rolling bearing grease resistant to media for temperatures up to +250 °C	PTFE Alkoxyfluoroether	TEMP200
GA47	Rolling bearing grease resistant to media for temperatures up to +140 °C	Barium complex soap Mineral oil	–
L178	Rolling bearing grease for high speeds	Barium complex soap PAO oil	–

continued ▼

1) GA stands for Grease Application Group, based on Grease Spec 00.

 **5**
Recommended greases
for radial insert ball bearings

Designation	Operating temperature range °C		Upper continuous limit temperature $\vartheta_{upper\ limit}^{2)}$ °C	NLGI class		Speed parameter $n \cdot d_M$ $\text{min}^{-1} \cdot \text{mm}$	ISO VG class (base oil)	
	from	to		from	to		from	to
GA13	–30	+120	+75	3	–	500 000	68	150
GA22	–50	+120	+70	2	–	1 500 000	10	22
L069	–40	+180	+120	2	–	700 000	68	220
GA11	–30	+260	+200	2	–	300 000	460	680
GA47	–20	+130	+70	1	2	350 000	150	320
L178	–20	+142	+75	2	–	800 000	22	46

continued ▲

2) The upper continuous limit temperature $\vartheta_{upper\ limit}$ must not be exceeded if a temperature-induced reduction in grease operating life is to be avoided.

Compatibility with plastic cages

When using bearings with plastic cages, compatibility between the lubricant and the cage material must be ensured if synthetic oils, lubricating greases with a synthetic oil base or lubricants containing a high proportion of EP additives are used.

Radial insert ball bearings in corrosion-resistant VA design

Initial greasing is carried out with an aluminium complex soap grease with food applications approval to NSF-H1, which is sufficient in many cases for the operating life of the bearings. For relubrication, the outer rings have lubrication holes on their circumference.

Black Series

The Black Series radial insert ball bearings in accordance with JIS are greased using a grease in Grease Group GA13 ► 1473 | 5.



1.5 Sealing

Non-contact or contact seals

A basic distinction is made between contact and non-contact seals in the adjacent construction and the bearing.

The sealing arrangement has a considerable influence on the operating life of a bearing arrangement. Its function is to retain the lubricant in the bearing and prevent the ingress of contaminants into the bearing.

Contaminants may have various effects:

- A large quantity of very small, abrasive particles causes wear in the bearing. The increase in clearance or noise brings the operating life of the bearing to an end
- Large, overrolled hard particles reduce the fatigue life since pittings occur at the indentation points under high bearing loads.

Type-specific seals

The different designs of seals are explained below. The type-specific seals used in the individual radial insert ball bearings are summarised in the table of features ▶ 1466 | 3 and ▶ 1468 | 4.

Overview of seal types

Seals for radial insert ball bearings are of a three-piece design. This concept offers, due to the rigidly rolled-in inner sheet steel washer, optimum seating in the bearing as well as concentric alignment of the seal lip to the inner ring. The contact seals on both sides of the bearing give protection against contamination and the loss of lubricant.

Seals for radial insert ball bearings are available in various designs ▶ 1474 | 6. The stated suffix is included in the ordering designation and explained in the table of suffixes ▶ 1485 | 1.12.

6
Seal types

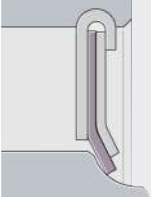
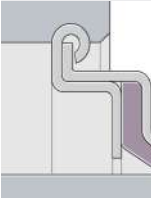
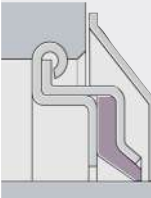
P seal (NPP)	
	0008C5D4 Two zinc-coated sheet steel washers (or in a corrosion-resistant VA design) with intermediate NBR part, seal lip axially preloaded. In order to protect the seal lip from mechanical damage, the outer sheet steel washer extends a considerable distance down towards the bearing inner ring. For use in narrow radial insert ball bearings with inner ring extended on one side.
R seal (KRR)	
	0008BC1D Two zinc-coated sheet steel washers extended outwards and angled downwards with intermediate NBR or PTFE part and radially preloaded seal lip. Improved protection against mechanical damage. Substantial grease reservoir due to the sheet steel washers which are extended outwards and angled downwards. Used in radial insert ball bearings with inner ring extended on both sides.
R seal with flinger shield (KRR--2C)	
	0008BC26 As R seal, but with outer flinger shield with corrosion protection. Additional sealing action without restriction on speed and with additional protection against mechanical damage.
continued ▼	

 6
Seal types

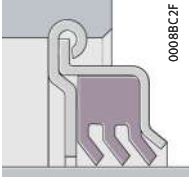
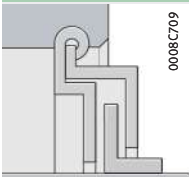
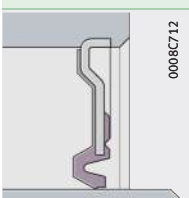
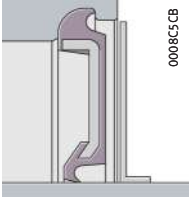
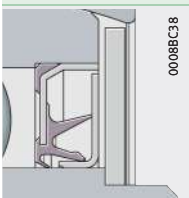
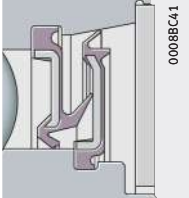
T seal (KTT)	
	0008BC2F Two zinc-coated sheet steel washers with intermediate NBR part and three radially preloaded seal lips for protection against heavy contamination. For better protection of the seal lip against mechanical damage, the outer sheet steel washer is extended outwards and angled downwards and outwards. Lower speeds due to higher friction.
L seal (labyrinth seal) (KLL)	
	0008C709 Two zinc-coated sheet steel washers extended outwards in the outer ring with a zinc-coated intermediate sheet steel L-section ring pressed onto the inner ring. Substantial grease reservoir due to the sheet steel washers which are extended outwards and angled downwards. For use in bearings with inner ring extended on both sides. For increased temperatures and lower friction.
RSR seal (2RSR)	
	0008C712 Single piece, zinc-coated sheet steel washer with vulcanised and radially preloaded seal lip made from NBR. Used in radial insert ball bearings with integral adapter sleeve.
RSR seal with flinger shield	
	0008C5CB Single piece, sheet steel washer in corrosion-resistant VA design with vulcanised and radially preloaded seal lip made from NBR and additional flinger shield. In the Black Series, the flinger shield has a Durotect BS coating.
Sealing cartridge with flinger shield	
	0008C5B8 Design identical to normal cartridge seal but supplemented by a flinger shield to protect the bearing against high pressure cleaning equipment and mechanical damage.
Combined sealing washer and flinger shield with protective shield	
	0008BC41 Design identical to normal sealing washer and flinger shield but supplemented by a protective shield to protect the bearing against high pressure cleaning equipment and mechanical damage.

continued ▲



Suitable for very high speeds

BRS seals

Bearings with BRS seals can be supplied by agreement ► 1476 | 25. The friction in this case is as low as that in bearings with sealing shields. They have the advantage over these, however, that the outer rubber-elastic rim gives good sealing when fitted in the slot in the outer ring. This is important in the case of a rotating outer ring, since the base oil in the grease is separated from the soap suspension by centrifugal force and would escape through the unsealed metallic seat in the outer ring if sealing shields were fitted.

25
BRS seals

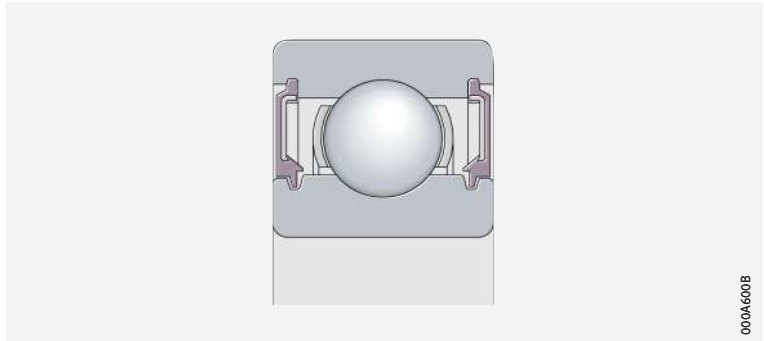

Non-contact seals in the adjacent construction

With non-contact seals, only lubricant friction occurs in the lubrication gap. The seals do not undergo wear and remain capable of operation for a long period. Since they generate no heat, non-contact seals are also suitable for very high speeds.

1.6 Speeds

Speed limits for radial insert ball bearings

The speed limits are dependent on the load, the clearance between the bearing bore and shaft and the friction of the seals in the case of bearings with contact seals.

Speed limits are guide values

Guide values for the permissible speeds can be derived from the diagram ► 1477 | 26.

In the case of load ratios $C_r/P > 13$, the speeds can be increased. At $C_r/P < 5$, location by means of a fit is recommended for a shaft roughness of Ra 0,3 ► 145. In order to ensure slippage-free operation, the minimum radial load must be observed ► 1491 | 1.15.

26

Permissible speeds for radial insert ball bearings

n = permissible speed
 d = bore diameter
 C_r/P = load ratio
 $h5, h6, h9$ = shaft tolerance
 (subject to envelope
 requirement ⑥)

- ① Ball set
- ② With $d = 12$ mm, 15 mm and 17 mm, identical ball set 203
- ③ For radial insert ball bearings with seals L, P or R
- ④ For radial insert ball bearings with seals T

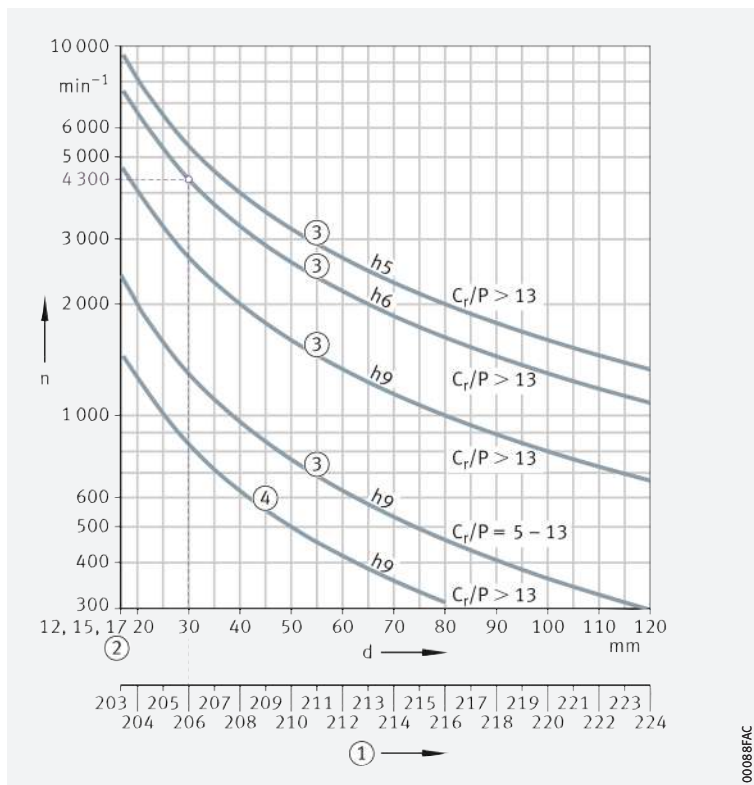

In the stated applications with load ratios $C_r/P < 5$, please contact us.

Example of permissible speed calculation

Given:

■ Shaft tolerance	$h6$ ⑥
■ Radial insert ball bearing	GRAE30-XL-NPP-B
■ Ball set	206
■ Basic dynamic load rating C_r	20 700 N
■ Load P	1 300 N
■ Sealing	seals P.

Required:

■ Load ratio	$C_r/P = 20\,700\text{ N}/1\,300\text{ N}$	$C_r/P > 13$
■ Permissible speed	$n \approx 4\,300\text{ min}^{-1}$	$\blacktriangleright 1477$ ② 26.



1.7 Noise

Schaeffler Noise Index

The Schaeffler Noise Index (SGI) is not yet available for this bearing type $\blacktriangleright 69$. The data for these bearing series will be introduced and updated in stages.

Further information:

■ **medias** \blacktriangleright <https://medias.schaeffler.com>.

1.8 Temperature range

The possible operating temperatures of radial insert ball bearings may differ according to the cage design and the material of the seal lips
➤ 1478 | 7.

Radial insert ball bearings for a high or expanded temperature range have the suffixes FA164 or FA101 in the designation ➤ 1466 | 3.

 7
Permissible temperature ranges

Operating temperature °C	Radial insert ball bearing							
	with polyamide cage PA66		with sheet steel cage				with high grade steel cage	
	with NBR seal lip		with PTFE seal lip and labyrinth seal				with NBR seal lip	
	°C		°C		°C		°C	
	from	to	from	to	from	to	from	to
	-20	+100 ¹⁾²⁾	-40	+180	+150	+250	-35	+100
					FA101 ³⁾	FA164 ⁴⁾		

- 1) Temporary temperature peaks are possible up to +120 °C.
- 2) In the case of radial insert ball bearings with a rubber interliner, the maximum operating temperature is reduced to +85 °C.
- 3) High and low temperature design (suffix FA101) ➤ 1485 | 1.12.
- 4) High temperature design (suffix FA164) ➤ 1485 | 1.12.

Limiting values

The operating temperature of the bearings is limited by:

- the dimensional stability of the bearing rings and rolling elements
- the cage
- the lubricant
- the seals.



In the event of anticipated temperatures which lie outside the stated values, please contact Schaeffler.

1.9 Cages

Rolling bearing cages are subdivided into sheet metal and solid cages. Both sheet metal and solid cages for radial insert ball bearings are exclusively ball-guided.

The most important functions of the cage are:

- to separate the rolling elements from each other, in order to minimise friction and heat generation
- to maintain the rolling elements at the same distance from each other, in order to ensure uniform load distribution
- to guide the rolling elements in the unloaded zone of the bearing.

Sheet metal cages

These cages are predominantly made from steel ➤ 1479 | 27.

In comparison with solid cages made from metal, they are of lower mass.

Since a sheet metal cage only fills a small proportion of the gap between the inner and outer ring, lubricant can easily reach the interior of the bearing and is held on the cage.

27

Radial insert ball bearing
with sheet metal cages

① Riveted cage

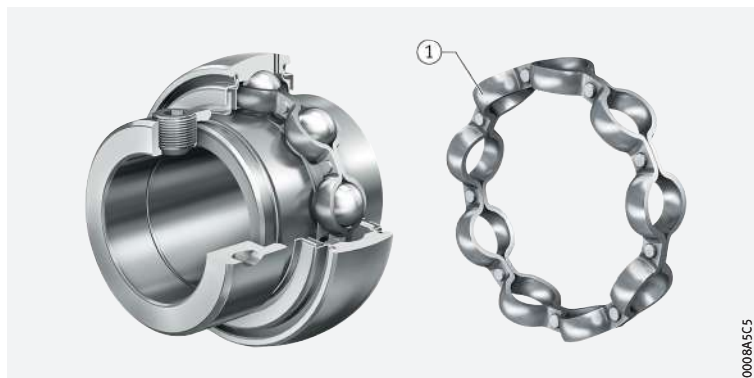

0008A5C5

Solid cages made from polyamide PA66

Solid cages made from polyamide PA66 are produced using the injection moulding process ▶ 1479 | 28 and ▶ 1479 | 29. As a result, cage types can generally be realised that allow designs with particularly high load carrying capacity. The elasticity and low mass of polyamide are favourable under shock type bearing loads, high accelerations and decelerations and tilting of the bearing rings in relation to each other. Polyamide cages have very good sliding and emergency running characteristics.

Cages made from glass fibre reinforced polyamide PA66 are suitable for continuous temperatures up to +120 °C. Due to the NBR seal used, the continuous temperature for the radial insert ball bearing is reduced ▶ 1478 | 1.8.

28

Solid polyamide cage
for standard bearings

① Polyamide cage

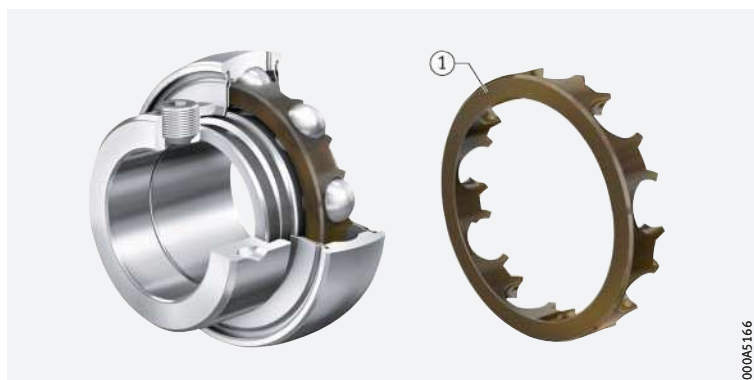

000A5166

29

Solid polyamide cage
for Black Series

① Polyamide cage



0008A5D7

1.10 Internal clearance



The differentiation of radial insert ball bearings between the ISO range and JIS range (Black Series) must be taken into consideration for the radial internal clearance.

Radial internal clearance of radial insert ball bearings

The radial internal clearance of most series is Group 3 in accordance with ISO 5753-1 ▶1466|8 and is thus larger than for normal deep groove ball bearings ▶1480|8. The radial internal clearance is subdivided into groups in accordance with ISO 5753-1 ▶1480|30.

The larger internal clearance allows better support of misalignments and shaft deflections.

30
Radial internal clearance

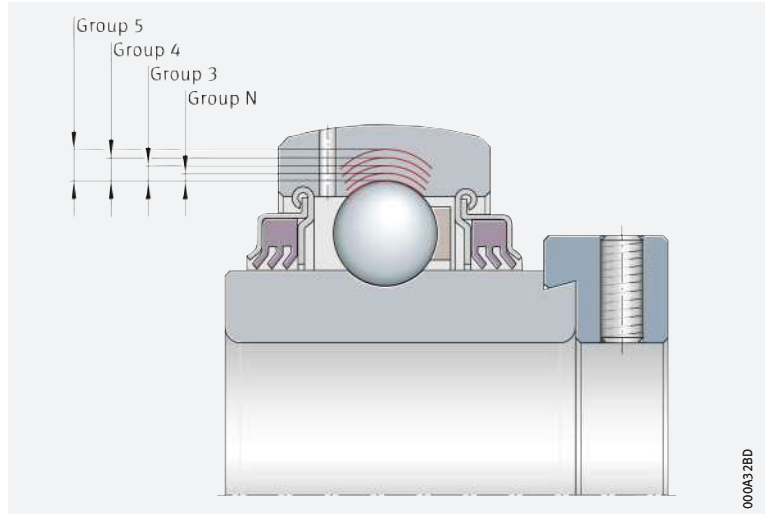

8
Radial internal clearance
of radial insert ball bearings
(excluding Black Series)

Bore d mm		Radial internal clearance							
		Group N μm		Group 3 μm		Group 4 μm		Group 5 μm	
over	incl.	min.	max.	min.	max.	min.	max.	min.	max.
2,5	6	2	13	8	23	–	–	–	–
6	10	2	13	8	23	14	29	20	37
10	18	3	18	11	25	18	33	25	45
18	24	5	20	13	28	20	36	28	48
24	30	5	20	13	28	23	41	30	53
30	40	6	20	15	33	28	46	40	64
40	50	6	23	18	36	30	51	45	73
50	65	8	28	23	43	38	61	55	90
65	80	10	30	25	51	46	71	65	105
80	100	12	36	30	58	53	84	75	120
100	120	15	41	36	66	61	97	90	140
120	140	18	48	41	81	71	114	105	160
140	160	18	53	46	91	81	130	120	180

Radial internal clearance of Black Series (radial insert ball bearings in accordance with JIS)

The radial internal clearance in accordance with JIS B 1520 is C3 for radial insert ball bearings UC and C4 for radial insert ball bearings UK. It is thus larger than in the case of normal deep groove ball bearings ► 1481  9. The larger internal clearance allows better support of misalignments and shaft deflections.

 9
Radial internal clearance
of Black Series

Bore		Ball set	Outside diameter D mm	Radial internal clearance			
d mm	inch			C3 μm		C4 μm	
				min.	max.	min.	max.
12	–	204	47	13	28	20	36
12,7	1/2						
14,288	9/16						
15	–						
15,875	5/8						
17	–						
17,462	11/16						
19,05	3/4						
20	–	205	52	13	28	23	41
20,638	13/16						
22,225	7/8						
23,812	15/16						
25	–						
25,4	1						
26,988	1 1/16						
28,575	1 1/8						
30	–	206	62	15	33	28	46
30,162	1 3/16						
31,75	1 1/4						
31,75	1 1/4						
33,338	1 5/16						
34,925	1 3/8						
35	–						
36,512	1 7/16						
38,1	1 1/2	207	72	18	36	30	51
39,688	1 9/16						
40	–						
41,275	1 5/8						
42,862	1 11/16						
44,45	1 3/4						
45	–						
46,038	1 13/16						
47,625	1 7/8	208	80	18	36	30	51
49,212	1 15/16						
50	–						
50,8	2						

continued ▼



 9
Radial internal clearance
of Black Series

Bore		Ball set	Outside diameter D mm	Radial internal clearance			
d				C3		C4	
mm	inch			μm	μm	μm	μm
			min.	max.	min.	max.	
50,8	2	211	100				
52,388	2 ¹ / ₁₆						
53,975	2 ¹ / ₈						
55	–						
55,562	2 ³ / ₁₆						
57,15	2 ¹ / ₄	212	110	23	43	38	61
58,738	2 ⁵ / ₁₆						
60	–						
60,325	2 ³ / ₈						
61,912	2 ⁷ / ₁₆						
63,5	2 ¹ / ₂	213	120				
65	–						
65,09	2 ⁹ / ₁₆						
66,675	2 ⁵ / ₈	214	125				
68,262	2 ¹¹ / ₁₆						
69,85	2 ³ / ₄						
70	–						
71,438	2 ¹³ / ₁₆						
73,025	2 ⁷ / ₈	215	130	25	51	46	71
74,612	2 ¹⁵ / ₁₆						
75	–						
76,2	3						
77,787	3 ¹ / ₁₆						
79,375	3 ¹ / ₈	216	140				
80	–						
80,962	3 ³ / ₁₆						
82,55	3 ¹ / ₄						
84,137	3 ⁵ / ₁₆						
85	–	217	150				
87,312	3 ⁷ / ₁₆						
88,9	3 ¹ / ₂						
90	–	218	160	30	58	53	84
93,662	3 ¹¹ / ₁₆	219	170				
95	–						
100	–	220	180				
100,012	3 ¹⁵ / ₁₆						
101,6	4						

continued ▲

1.11 Dimensions, tolerances



The main dimensions of the standard bearings and corrosion-resistant radial insert ball bearings correspond to ISO 9628 and DIN 626-1 **➤ 1508**

The main dimensions of the Black Series correspond to JIS B 1558 **➤ 1558**



The limiting dimensions for chamfer dimensions correspond to DIN 620-6. Overview and limit values **➤ 135**.



Symmetrical ring cross-section with identical chamfer dimensions on both rings

d = inside diameter
 r_1, r_2 = chamfer dimensions

- ① Arc (radius with nominal chamfer dimension) beyond which material must not protrude
- ② Radial
- ③ Axial

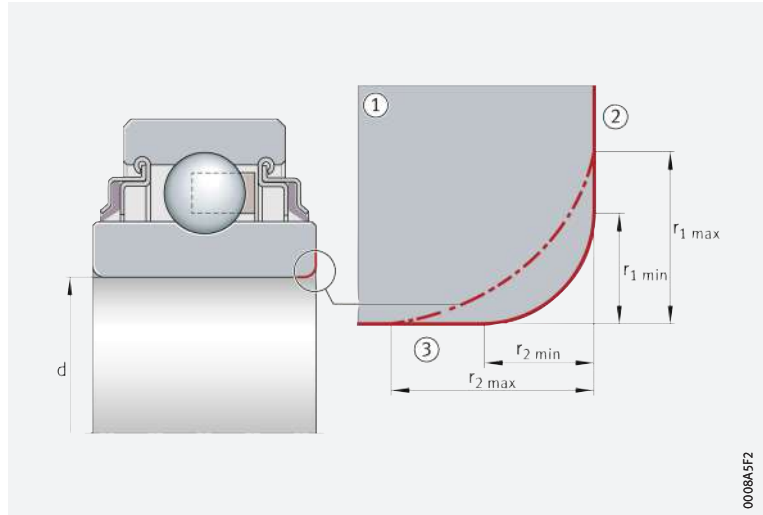

Normal tolerances of standard bearings

The outside diameter of the bearings corresponds to tolerance class Normal in accordance with ISO 492 **➤ 1483** 10. The inner ring bore has a plus tolerance to facilitate mounting of the bearing.



Tolerances of radial insert ball bearings

Tolerance symbols **➤ 115** 6
 U = upper limit deviation
 L = lower limit deviation

Inner ring				Outer ring			
Nominal dimension Bore d mm		Deviation $t_{\Delta dmp}$ μm		Nominal dimension Outside diameter D mm		Deviation ¹⁾²⁾ $t_{\Delta Dmp}$ μm	
over	incl.	L	U	over	incl.	U	L
12	18	0	+18	30	50	0	-11
18	24	0	+18	50	80	0	-13
24	30	0	+18	80	120	0	-15
30	40	0	+18	120	150	0	-18
40	50	0	+18	150	180	0	-25
50	60	0	+18	180	250	0	-30
60	90	0	+25	-	-	-	-
90	120	0	+30	-	-	-	-

1) In the case of sealed bearings, the largest and smallest values of the outside diameter can deviate from the mean value by approximately 0,03 mm.
 2) Outside diameter tolerances also valid for 2...-KRR and 2...-NPP-B.



Standard tolerances of corrosion-resistant radial insert ball bearings

The outside diameter of the bearings corresponds to tolerance class Normal in accordance with ISO 492 ▶ 1484 | 11 and ▶ 1484 | 12. The inner ring bore has a plus tolerance to facilitate mounting of the bearing.

11 Tolerances of radial insert ball bearings, with Corrotect coating

Tolerance symbols ▶ 115 | 6

U = upper limit deviation

L = lower limit deviation

Inner ring				Outer ring			
Nominal dimension Bore d mm		Deviation		Nominal dimension Outside diameter D mm		Deviation ¹⁾	
over	incl.	L	U	over	incl.	U	L
12	18	0	+18	30	50	0	-11
18	24	0	+18	50	80	0	-13
24	30	0	+18	80	120	0	-15
30	40	0	+18	120	150	0	-18
40	50	0	+18	150	180	0	-25
50	60	0	+18	180	250	0	-30
60	90	0	+25	-	-	-	-
90	120	0	+30	-	-	-	-

¹⁾ In the case of sealed bearings, the largest and smallest values of the outside diameter can deviate from the mean value by approx. 0,03 mm.

12 Tolerances of radial insert ball bearings, corrosion-resistant VA design

Tolerance symbols ▶ 115 | 6

U = upper limit deviation

L = lower limit deviation

Inner ring				Outer ring			
Nominal dimension Bore d mm		Deviation		Nominal dimension Outside diameter D mm		Deviation ¹⁾	
over	incl.	L	U	over	incl.	U	L
18	24	0	+25	50	80	0	-13
24	30	0	+25	80	120	0	-13
30	40	0	+25	120	150	0	-13
40	50	0	+25	150	180	0	-13
50	60	0	+25	180	250	0	-13

¹⁾ In the case of sealed bearings, the largest and smallest values of the outside diameter can deviate from the mean value by approx. 0,03 mm.

Normal tolerances of Black Series (radial insert ball bearings in accordance with JIS)

The outside diameter tolerances of the bearings correspond to the tolerances in accordance with JIS B 1558 ▶ 1484 | 13. The inner ring bore has a plus tolerance to facilitate mounting of the bearing.

13 Tolerances of inner ring, Black Series

Nominal bearing bore diameter d mm		Deviation ¹⁾ Δ_{dmp} μm		Width deviation Δ_{Bs} μm	
over	incl.	min.	max.	min.	max.
10	18	0	+15	-120	0
18	31,75	0	+18	-120	0
31,75	50,8	0	+21	-120	0
50,8	80,962	0	+24	-150	0
80,962	120	0	+28	-200	0

¹⁾ This corresponds to the arithmetic mean value derived from the largest and smallest diameters (measured using a two-point measuring device).

14
Tolerances of outer ring,
Black Series

Nominal outside diameter		Deviation ¹⁾	
D _{sp} mm		Δ _{Dm} μm	
over	incl.	min.	max.
30	50	-11	0
50	80	-13	0
80	120	-15	0
120	150	-18	0
150	180	-25	0
180	250	-30	0

¹⁾ In the case of sealed bearings, the largest and smallest values of the outside diameter can deviate from the mean value by approx. 0,03 mm.

1.12 Suffixes

The suffix defines special designs and features and follows the basic designation in the ordering designation ► 1485| 15 and ► 1485| 16.

15
Suffixes and
corresponding descriptions



Suffix	Description	
AS2/V	Bearing outer ring with two lubrication holes in two offset planes (instead of one plane)	Standard
B	Bearing with spherical outside surface of outer ring	
2C	Flinger shield on both sides	
FA	Manufacturing variant	Standard
FA101	High and low temperature design -40 °C to +180 °C	
FA106	Bearing subjected to special noise testing	
FA107	Bearing with lubrication holes on the locating side	
FA125	With Corrotect coating, corrosion-resistant	
FA164	High temperature design from +150 °C to +250 °C	Standard
KRR	Lip seal on both sides (seal R)	
KLL	Labyrinth seal on both sides (seal L)	
KTT	Triple lip seal on both sides (seal T)	
NPP	Lip seal on both sides (seal P)	
2RSR	Lip seal on both sides (vulcanised)	Standard
AH	Features differing from the original	
NR	Slot and snap ring for radial insert ball bearing with cylindrical outer ring	
OSE	Bearing without locking element (eccentric locking collar)	
XL	Bearing design in X-life quality	



16
Suffixes and
corresponding descriptions,
additional notations for
(self-aligning) deep groove
ball bearings

Suffix	Description	
L402/70	Grease code according to Schaeffler standard, 70% grease quantity	Available by agreement
GA47/70	Grease Group, 70% grease quantity	

1.13 Structure of bearing designation



The designations of radial insert ball bearings with an extended inner ring and (self-aligning) deep groove ball bearings follow an almost identical model ➤ 1486| 17, ➤ 1486| 32 and ➤ 1487| 33. Radial insert ball bearings with a steel aligning ring or rubber interliner differ from this model ➤ 1487, which is also the case for Black Series and corrosion-resistant radial insert ball bearings ➤ 1488.

 **17**
Basic designations and corresponding descriptions for radial insert ball bearings with extended inner ring or (self-aligning) deep groove ball bearings

	Basic designation	Description of basic designation	
		Stated in designation	Not stated
①	G	Relubrication facility	Without relubrication facility
②	N	Heavy bearing series (bearing series 63)	Standard bearing series (bearing series 62)
	RA	Location of inner ring by means of eccentric locking collar, with inner ring extended on one side	
	AY	Location of inner ring by means of two grub screws, with inner ring extended on one side	
	SH	Location of inner ring by means of adapter sleeve (special ball set)	
② + ③	RAL	Location of inner ring by means of eccentric locking collar, light bearing series (bearing series 60)	
	VK	Inner ring with square bore	Inner ring with a cylindrical bore
	SK	Inner ring with hexagonal bore	
③	Y	Location of inner ring by means of two grub screws, with inner ring extended on both sides	Location of inner ring by means of eccentric locking collar, with inner ring extended on both sides
	L	Inner ring with drive slot (non-locating bearing)	
④	E	Metric bore	Inch size bore
	1	Inch size bore (only for inner ring extended on both sides)	
⑤	50	Bore code; bore diameter in mm (example: 50 = 50 mm)	–
	012 ¹⁾	Bore code; bore diameter in inches (example: 012 = 3/4 inch)	–
⑤ + ⑥	204 ²⁾	Ball set code (sole notation for (self-aligning) deep groove ball bearings; inner ring with fit)	–
⑥	214	Ball set 214 (additional notation)	Standard (ball set 213)

- 1) Three-digit notation for bore diameter. The first digit is complete inches, while the last two digits are stated in sixteenths, for example 12/16.
- 2) The first digit of the ball set code corresponds to the standardised series designation for radial deep groove ball bearings without the leading 6, for example bearing series 62. The other digits represent the bore code, for example 04. For all rolling bearings in the range from d = 20 mm to d = 480 mm, the bore code is created by dividing the dimension of the bearing bore by 5.

 **32**
Radial insert ball bearing with extended inner ring: designation structure

- ① – ⑥ Basic designation
➤ 1486| 17
- ⑦ – ⑬ Suffixes
➤ 1485| 15

Example:
GE80-XL-KRR-B-AH01-FA164

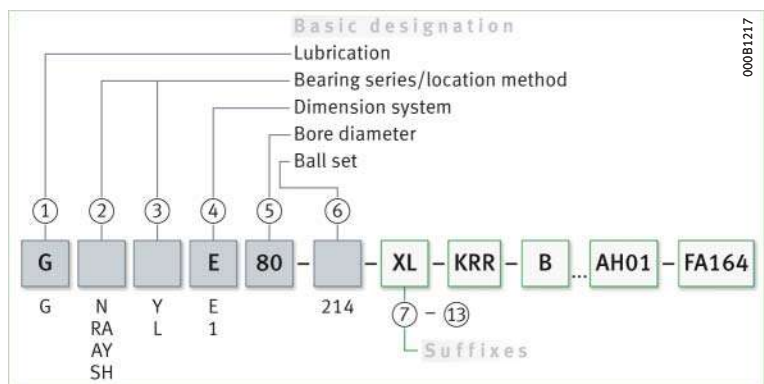

33

(Self-aligning) deep groove ball bearing: designation structure

- ① – ⑥ Basic designation
▶ 1486 | 17
- ⑦ – ⑫ Suffixes
▶ 1485 | 15 and
▶ 1485 | 16

Example:
GVKE16-205-KRR-B-2C-AS2/V-
L402/70-AH01

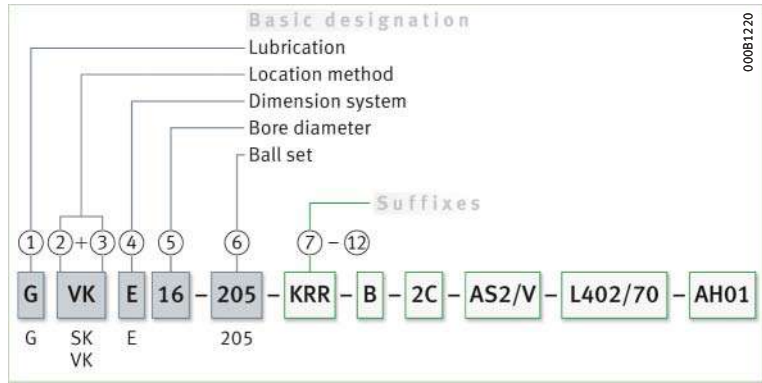

Radial insert ball bearings with steel aligning ring or rubber interliner

Radial insert ball bearings with a steel aligning ring or rubber interliner follow a separate designation model ▶ 1487 | 18 and ▶ 1487 | 19.

18

Basic designations and corresponding descriptions for radial insert ball bearings with steel aligning ring

▶ 34	Basic designation	Description of basic designation
①	B	Self-aligning deep groove ball bearing
	P	Radial insert ball bearing with eccentric locking collar
②	E	Aligning ring

19

Basic designations and corresponding descriptions for radial insert ball bearings with rubber interliner

▶ 35	Basic designation	Description of basic designation
①	CR	Rubber interliner with locating shoulder
	RABR	Rubber interliner with spherical outside surface
	RCR	Rubber interliner with cylindrical outside surface and mounting chamfer
	RCSM	Rubber interliner with cylindrical outside surface
②	B	Radial insert ball bearing RAE...NPP-B ▶ 1486 17
	A	Radial insert ball bearing RALE...NPP-B ▶ 1486 17

34

Radial insert ball bearing with steel aligning ring: designation structure

- ① – ② Basic designation
▶ 1487 | 18
- ③ Diameter in mm
- ④ Suffixes
▶ 1485 | 15

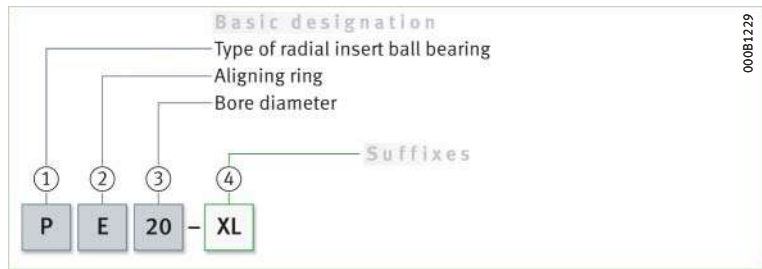

35

Radial insert ball bearing with rubber interliner: designation structure

- ① – ② Basic designation
▶ 1487 | 19
- ③ Diameter in mm
- ④ Suffixes
▶ 1485 | 15

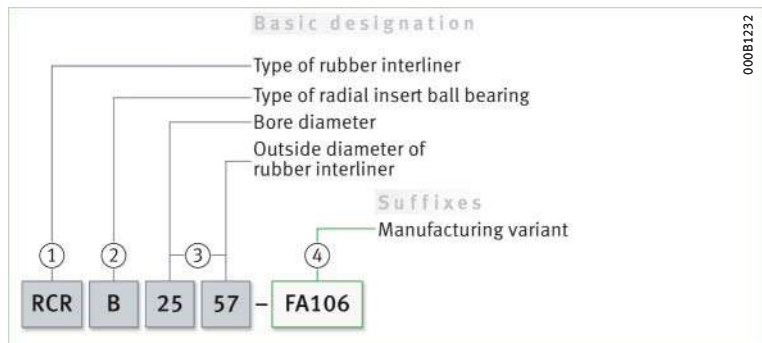

Black Series and corrosion-resistant radial insert ball bearings

Radial insert ball bearings in accordance with JIS (Black Series) and corrosion-resistant radial insert ball bearings follow a separate designation model ▶ 1488 | 20.

20
Basic designations and corresponding descriptions for Black Series and corrosion-resistant radial insert ball bearings

Basic designation	Description of basic designation	
	Stated in designation	Not stated
S	High grade steel design of radial insert ball bearing	Normal design (for Black Series)
UB	Inner ring extended on one side, with grub screws	-
UC	Inner ring extended on both sides, with grub screws and flinger shields on both sides	
UG	Inner ring extended on one side, with eccentric locking collar	
UK	With adapter sleeve in accordance with JIS B 1552 and flinger shields on both sides	
208 ¹⁾	Ball set code, metric dimensions	
208-24 ²⁾	Ball set code, bore diameter in inch dimensions	

1) The first digit of the ball set code corresponds to the standardised series designation for radial deep groove ball bearings without the leading 6, for example bearing series 62.

The other digits represent the bore code, for example 08. For all rolling bearings in the range from $d = 20$ mm to $d = 480$ mm, the bore code is created by dividing the dimension of the bearing bore by 5.

2) Notation for bore diameter in sixteenths, for example $24/16 = 1\frac{1}{2}$ inch.

36
Black Series and corrosion-resistant radial insert ball bearings: designation structure

Basic designation ▶ 1488 | 20

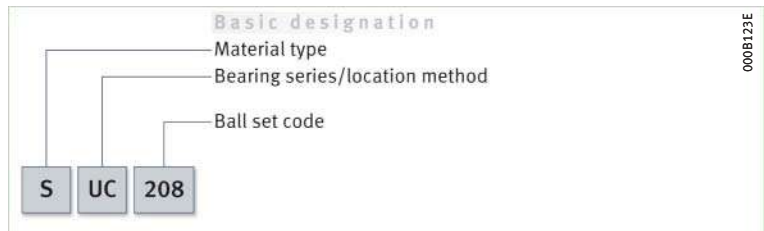

1.14 Dimensioning

Equivalent dynamic bearing load

$P = F_r$ under purely radial load of constant magnitude and direction

P is a substitute force for combined load and various load cases

The basic rating life equation $L = (C_r/P)^P$ used in the dimensioning of bearings under dynamic load assumes a load of constant magnitude and direction. In radial bearings, this is a purely radial load F_r . If this condition is met, the bearing load F_r is used in the rating life equation for P ($P = F_r$).

If this condition is not met, a constant radial force must first be determined for the rating life calculation that (in relation to the rating life) represents an equivalent load. This force is known as the equivalent dynamic bearing load P .

$F_a/F_r \leq e$ or $F_a/F_r > e$ The calculation of P is dependent on the load ratio F_a/F_r and the calculation factor e \blacktriangleright 1489 | f_1 1 and \blacktriangleright 1489 | f_1 2.

f_1
Equivalent dynamic load

$$\frac{F_a}{F_r} \leq e \Rightarrow P = F_r$$

f_2
Equivalent dynamic load

$$\frac{F_a}{F_r} > e \Rightarrow P = X \cdot F_r + Y \cdot F_a$$

Legend

P	N	Equivalent dynamic bearing load
F_r	N	Radial load
F_a	N	Axial load
e, X, Y	-	Factors \blacktriangleright 1489 \square 21.

\blacktriangleright Factors e, X, Y and f_0

The values for the factors e, X and Y are valid for normal fits (shaft produced to j5 $\text{\textcircled{E}}$ or k5 $\text{\textcircled{E}}$, housing bore produced to J6 $\text{\textcircled{E}}$). If the calculation values lie between the stated values (for example 0,4), read off the table values for 0,3 and 0,5 and determine the intermediate values using linear interpolation.

\square 21
Factors e, X and Y

$f_0 \cdot F_a$ C_{Or}	Factor for radial internal clearance								
	Group N			Group 3			Group 4		
	e	X	Y	e	X	Y	e	X	Y
0,3	0,22	0,56	2	0,32	0,46	1,7	0,4	0,44	1,4
0,5	0,24	0,56	1,8	0,35	0,46	1,56	0,43	0,44	1,31
0,9	0,28	0,56	1,58	0,39	0,46	1,41	0,45	0,44	1,23
1,6	0,32	0,56	1,4	0,43	0,46	1,27	0,48	0,44	1,16
3	0,36	0,56	1,2	0,48	0,46	1,14	0,52	0,44	1,08
6	0,43	0,56	1	0,54	0,46	1	0,56	0,44	1

Legend

f_0	-	Factor \blacktriangleright 1489 \square 22
F_a	N	Axial dynamic bearing load
C_{Or}	N	Basic static load rating \blacktriangleright 1508 \square 22.

\square 22
Factor f_0

Bore code	Factor f_0		
	60	62	63
3	-	12,9	-
4	-	12,2	12,4
5	-	13,2	12,2
6	-	13	-
7	13	12,4	-
8	12,4	13	-
9	13	12,4	-
00	12,4	12,1	11,3
01	13	12,3	11,1
02	13,9	13,1	12,1
03	14,3	13,1	12,3
04	13,9	13,1	12,4
05	14,5	13,8	12,4
06	14,8	13,8	13
07	14,8	13,8	13,1

continued \blacktriangledown



22
Factor f_0

Bore code	Factor f_0		
	60	62	63
08	15,3	14	13
09	15,4	14,3	13
10	15,6	14,3	13
11	15,4	14,3	12,9
12	15,5	14,3	13,1
13	15,7	14,3	13,2
14	15,5	14,4	13,2
15	15,7	14,7	13,2
16	15,6	14,6	13,2
17	15,7	14,7	13,1
18	15,6	14,5	13,9
19	15,7	14,4	13,9
20	15,9	14,4	13,8
21	15,8	14,3	13,8
22	15,6	14,3	13,8
24	15,9	14,8	13,5
26	15,8	14,5	13,6
28	16	14,8	13,6
30	16	15,2	13,7

continued ▲▼

22
Factor f_0

Bore code	Factor f_0		
	60	62	63
32	16	15,2	13,9
34	15,7	15,3	13,9
36	15,6	15,3	13,9
38	15,8	15	14
40	15,6	15,3	14,1
44	15,6	15,2	14,1
48	15,8	15,2	14,2
52	15,7	15,2	–
56	15,9	15,3	–
60	15,7	–	–
64	15,9	–	–
68	15,8	–	–
72	15,9	–	–
76	–	–	–
80	–	–	–
84	–	–	–
88	–	–	–
92	–	–	–
96	–	–	–

continued ▲

Equivalent static bearing load

Radial insert ball bearings are based on single row deep groove ball bearings 60, 62 or 63.

$F_{0a}/F_{0r} \leq 0,8$ or
 $F_{0a}/F_{0r} > 0,8$

For deep groove ball bearings under static loading ▶ 1491 | § 3 and ▶ 1491 | § 4. The calculation of P_0 is dependent on the load ratio F_{0a}/F_{0r} and the factor 0,8.

f13
Equivalent static load

$$\frac{F_{0a}}{F_{0r}} \leq 0,8 \Rightarrow P_0 = F_{0r}$$

f14
Equivalent static load

$$\frac{F_{0a}}{F_{0r}} > 0,8 \Rightarrow P_0 = 0,6 \cdot F_{0r} + 0,5 \cdot F_{0a}$$

Legend

P_0	N	Equivalent static bearing load
F_{0r}, F_{0a}	N	Largest radial or axial load present (maximum load).

Static load safety factor

$S_0 = C_0/P_0$

In addition to the basic rating life $L_{(L_{10h})}$, it is also always necessary to check the static load safety factor S_0 ▶ 227 | f15.

f15
Static load safety factor

$$S_0 = \frac{C_0}{P_0}$$

Legend

S_0	-	Static load safety factor
C_0	N	Basic static load rating
P_0	N	Equivalent static bearing load.

1.15 Minimum load

Rolling bearings under low loads are particularly prone to slippage

If the lubricant film between the rolling elements and raceways is broken as a result of slippage, the contact partners will be in contact at a very high relative velocity and there will be an erratic increase in wear in the bearing. The risk of slippage is particularly high in the case of bearings under low loads.

Minimum radial load

In order to ensure slippage-free operation, the bearings must be subjected to a minimum radial load. This applies particularly in the case of high speeds and high accelerations. In continuous operation, ball bearings with cage must therefore be subjected to a minimum radial load of the order of $P \geq 0,01 \cdot C_r$.

1.16 Design of bearing arrangements

Shaft tolerances for radial insert ball bearings

The permissible shaft tolerance is dependent on the speed and load. Shafts up to tolerance class h9 @ can be used. Drawn shafts will suffice for most applications.

Roughness of cylindrical bearing seating surfaces

Ra must not be too high

The roughness of the bearing seats must be matched to the tolerance class of the bearings. The mean roughness value Ra must not be too high, in order to maintain the interference loss within limits. The shafts must be ground, while the bores must be precision turned. The roughness values stated as a function of the IT grade of the bearing seating surfaces are guide values ▶ 1491 | 23.

23
Roughness values for cylindrical bearing seating surfaces – guide values

Nominal diameter of bearing seat d (D) mm		Recommended mean roughness value for ground bearing seats R _{amax} µm			
		Diameter tolerance (IT grade)			
over	incl.	IT7	IT6	IT5	IT4
-	80	1,6	0,8	0,4	0,2
80	500	1,6	1,6	0,8	0,4



Suitable housing units for radial insert ball bearings

For radial insert ball bearings, Schaeffler offers the appropriate plummer block, flanged and take-up housings made from cast iron, sheet steel and plastic. The housings can, like the radial insert ball bearings themselves, also be provided in a corrosion-resistant design ▶ 1498 | 26.

Cast iron housings are always one-piece units and can support high loads. Sheet steel housings are two-piece units and are used where the priority is not the load carrying capacity of the housing but the low mass of the unit.

37 Plummer block housing unit

Cast iron housing
with integrated
radial insert ball bearing

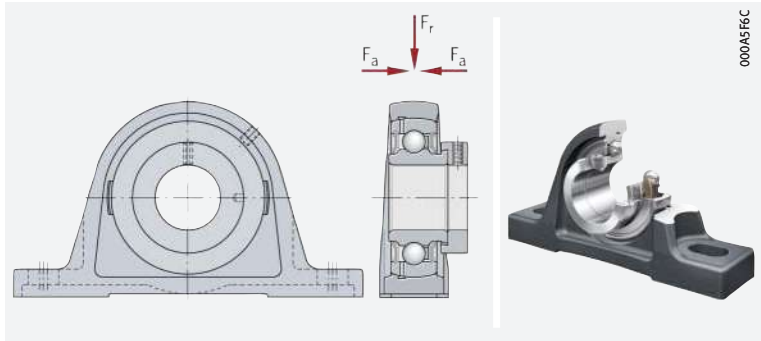

000A5F6C

38 Flanged housing unit

Sheet steel housing
with integrated
radial insert ball bearing

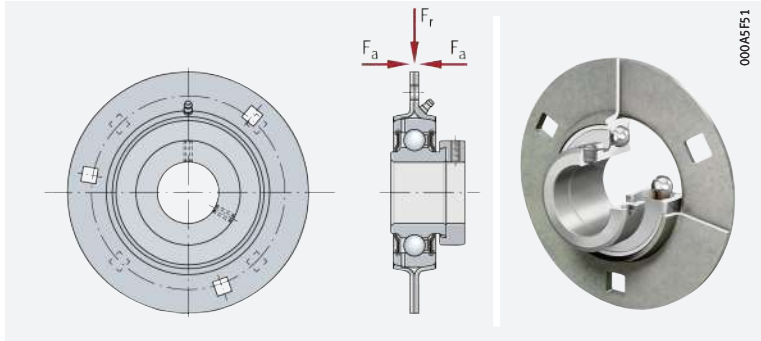

000A5F51

Ready-to-fit units eliminate the need for in-house production of the mounting environment for the bearings

The housing units comprise radial insert ball bearings with a spherical outer ring and a housing with a spherical bore to form ready-to-fit units. The user is thus spared the need for costly production of the mounting environment required for these bearings. The areas of application correspond to those of the radial insert ball bearings.

39 Example of the location of radial insert ball bearings with four-bolt flanged housing units PCJ in a pallet transport system

Design of shaft to tolerance class h9 ©

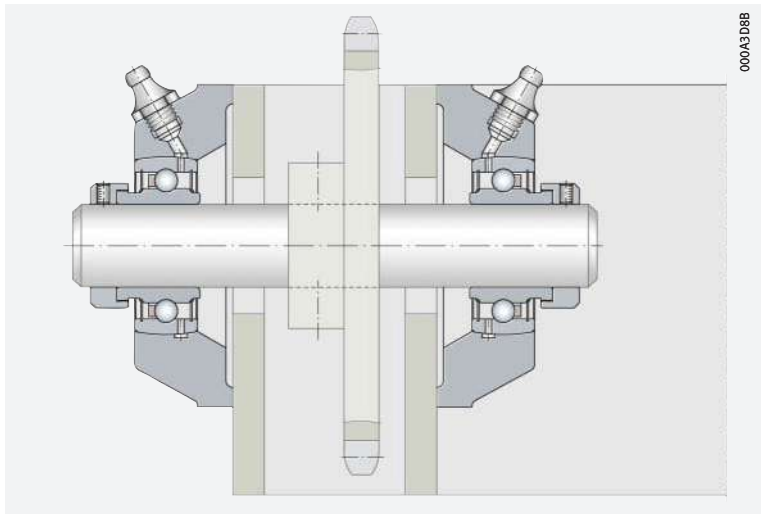

000A3D8B

Roller chain idler sprocket units and idler pulley units

Roller chain idler sprocket units and idler pulley units are tensioning elements for return units or belt drives ▶ 1493 | 40. Roller chain idler sprocket units can compensate for chain stretch resulting from operation and give smoother system running under high loads and velocities. Idler pulley units increase the wrap angle in belt drives and can therefore transmit higher power levels.



Roller chain idler sprocket units and idler pulley units from Schaeffler

- ① Roller chain idler sprocket unit KSR...-L0 made from steel
- ② Roller chain idler sprocket unit KSR...-L0-22 made from plastic
- ③ Idler pulley unit RSRA...-L0 for vee belts in accordance with DIN 2215 and ISO 1081

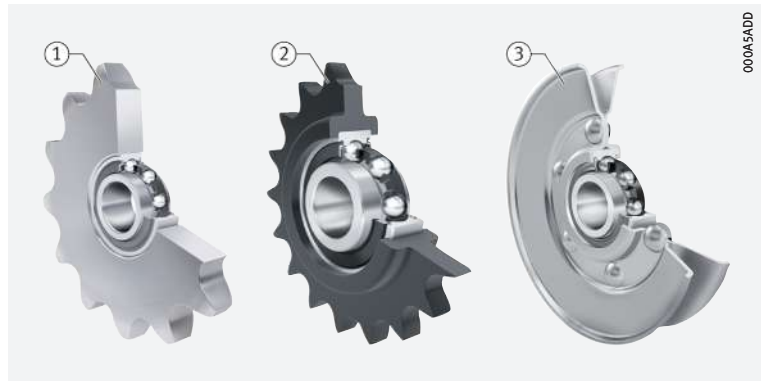

Overview of possible combinations

The following overviews represent the possible combinations of radial insert ball bearings with housings from Schaeffler:

- standard cast iron housings, ISO range ▶ 1494 | 24
- standard sheet steel housings, ISO range ▶ 1496 | 25
- corrosion-resistant cast iron and sheet steel housings ▶ 1498 | 26
- corrosion-resistant plastic housings ▶ 1500 | 27
- Black Series, cast iron housings, JIS range ▶ 1502 | 28.







Product tables and descriptions of the catalogue range of housing units as well as roller chain idler sprocket units and idler pulley units:

- Catalogue Radial Insert Ball Bearings and Housing Units ▶ SG 1
- Download and ordering ▶ <https://www.schaeffler.de/std/1D60>.

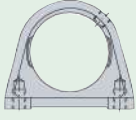
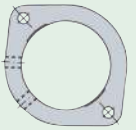
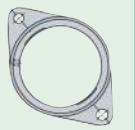
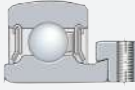
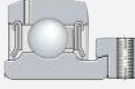
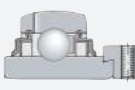
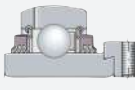
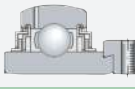
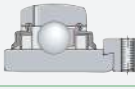
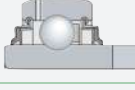

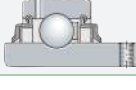
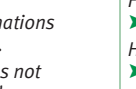
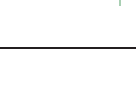
 **24** Possible combinations of radial insert ball bearings with cast iron housings

Radial insert ball bearing	Standard cast iron housing				
	Plummer block housing		Two-bolt flanged housing		Three-bolt flanged housing
					
Designation	ASE	SHE	LCTE¹⁾	CJT	CFTR
Shaft diameter d	SAO²⁾		GLCTE	CFT	
				CJTZ	
RAE..-XL-NPP-B 12 mm – 50 mm			FLCTE..-XL¹⁾		
GRAE..-XL-NPP-B 12 mm – 60 mm		PASE..-XL	PSHE..-XL	GLCTE..-XL	PC(J, F)T..-XL
GRA..-NPP-B-AS2/V 5/8" – 1 ¹⁵ /16"		Available by agreement	Available by agreement	Available by agreement	Available by agreement
GE..-XL-KRR-B 17 mm – 120 mm		RASE..-XL	RSHE..-XL		RCJT(Z)..-XL
G..-KRR-B-AS2/V 5/8" – 2 ¹⁵ /16"		Available by agreement	Available by agreement		Available by agreement
GE..-XL-KTT-B 20 mm – 80 mm		TASE..-XL	TSHE..-XL		TCJT..-XL
GE..-XL-KLL-B 20 mm – 50 mm		LASE..-XL	Available by agreement		LCJT..-XL
GNE..-XL-KRR-B²⁾ 30 mm – 100 mm		RSAO..-XL			
GLE..-XL-KRR-B 20 mm – 70 mm		RASEL..-XL	Available by agreement		Available by agreement
GSH..-XL-2RSR-B 20 mm – 50 mm		RASEA..-XL	Available by agreement		RCJTA..-XL
AY..-XL-NPP-B 12 mm – 30 mm				FLCTEY..-XL¹⁾	
GAY..-XL-NPP-B 12 mm – 60 mm		PASEY..-XL	PSHEY..-XL	FLCTEY..-XL¹⁾	PCJTY..-XL
GAY..-NPP-B(-AS2/V) 1/2" – 1 ⁷ /16"		Available by agreement	Available by agreement	Available by agreement	Available by agreement
GYE..-XL-KRR-B 12 mm – 90 mm		RASEY..-XL	RSHEY..-XL		RCJTY..-XL
GY..-KRR-B-AS2/V 1/2" – 2 ¹⁵ /16"		Available by agreement	Available by agreement		Available by agreement

Catalogue range; other dimensions and combinations available by agreement.
 Combinations not possible or not advisable.

Further information: SG 1
 ➤ <https://www.schaeffler.de/std/1D60>
 Housing selection wizard:
 ➤ <https://www.schaeffler.de/std/1D61>

- 1) Without lubrication hole.
- 2) Heavy series.

Four-bolt flanged housing		Take-up housing			
					
ME	CJ	TUE	HUE GEH..HUSE	HE	SFT
MEO²⁾	CJO²⁾	TUEO²⁾			
FE	CF				
PME..-XL	PCJ..-XL, PCF..-XL	PTUE..-XL	PHUSE..-XL	PHE..-XL	PSFT..-XL
Available by agreement	Available by agreement	Available by agreement	Available by agreement	Available by agreement	Available by agreement
RME..-XL, RFE..-XL	RCJ..-XL	RTUE..-XL	Available by agreement	RHE..-XL	Available by agreement
Available by agreement	Available by agreement	Available by agreement	Available by agreement	Available by agreement	Available by agreement
TME..-XL	TCJ..-XL	TTUE..-XL	Available by agreement	THE..-XL	Available by agreement
TFE..-XL					
Available by agreement	Available by agreement	Available by agreement	Available by agreement	Available by agreement	Available by agreement
RMEO..-XL	RCJO..-XL	RTUEO..-XL			
Available by agreement	RCJL..-XL	Available by agreement	Available by agreement	Available by agreement	Available by agreement
Available by agreement	Available by agreement	Available by agreement	Available by agreement	Available by agreement	Available by agreement
PMEY..-XL	PCJY..-XL	PTUEY..-XL	Available by agreement	PHEY..-XL	Available by agreement
Available by agreement	Available by agreement	Available by agreement		Available by agreement	
RMEY..-XL	RCJY..-XL	RTUEY..-XL	Available by agreement	Available by agreement	Available by agreement
Available by agreement	Available by agreement	Available by agreement			

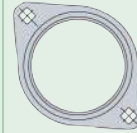

25 Possible combinations of radial insert ball bearings with sheet steel housings

Radial insert ball bearing	Standard sheet steel housing ¹⁾				
	Plummer block housing			Two-bolt flanged housing	
					
Designation	GEH...PBS	GEH...BT	GEH...BT GRG...RABR	FLAN...LST (2 pieces)	FLAN...MST (2 pieces)
Shaft diameter d					
RALE...XL-NPP(-B) 20 mm – 30 mm 			RPB...XL d = 30 mm	RALT...XL	
RAE...XL-NPP(-B) 12 mm – 40 mm 	PBS...XL	PB...XL	RPB...XL		RAT...XL
GRAE...XL-NPP-B 20 mm – 60 mm 					
(G)E...XL-KRR-B 17 mm – 60 mm 	To be ordered separately	To be ordered separately	To be ordered separately		To be ordered separately
GE...XL-KTT-B 20 mm – 60 mm 	To be ordered separately	To be ordered separately			To be ordered separately
GE...XL-KLL-B 20 mm – 50 mm 	To be ordered separately	To be ordered separately			To be ordered separately
GLE...XL-KRR-B 20 mm – 60 mm 	To be ordered separately	To be ordered separately			To be ordered separately
GSH...XL-2RSR-B 20 mm – 50 mm 	To be ordered separately	To be ordered separately			To be ordered separately
(G)AY...XL-NPP-B 12 mm – 60 mm 	To be ordered separately	PBY...XL			RATY...XL
GYE...XL-KRR-B 12 mm – 60 mm 	To be ordered separately	To be ordered separately			To be ordered separately

Catalogue range;
other dimensions and
combinations available
by agreement.

 Combinations not possible or not advisable.

Further information: SG 1
➤ <https://www.schaeffler.de/std/1D60>
Housing selection wizard:
➤ <https://www.schaeffler.de/std/1D61>

¹⁾ Housings have a Corroctect coating, suffix FA125.

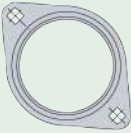
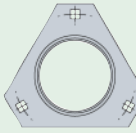
		Three-bolt flanged housing				Take-up housing
						
FLAN...CSLT FLAN...CST	FLAN...RCSMF GRG...RCSM	FLAN...MSB (2 pieces)	FLAN...MSA FLAN...MSB	FLAN...LSTR (2 pieces)	FLAN...MSTR (2 pieces)	GEH...MSTU
PCSLT...-XL	RCSMF...-XL d = 30 mm			RALTR...-XL		
	RCSMF...-XL	RA...-XL			RATR...-XL	MSTU...-XL
		RA...-XL	GRA...-XL			
		To be ordered separately	To be ordered separately		RRTR...-XL	To be ordered separately
		To be ordered separately	To be ordered separately		To be ordered separately	To be ordered separately
		To be ordered separately	To be ordered separately		To be ordered separately	To be ordered separately
		To be ordered separately	To be ordered separately		To be ordered separately	To be ordered separately
		RAY...-XL			RATRY...-XL	To be ordered separately
					To be ordered separately	To be ordered separately

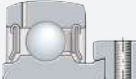
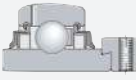
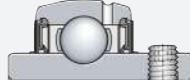

26
Possible combinations
of radial insert ball bearings
with cast iron or sheet steel
 housings, corrosion-resistant

Radial insert ball bearing ¹⁾	Cast iron housing ¹⁾
	Plummer block housing
Designation	ASE
Shaft diameter d	
GRAE..-XL-NPP-B-FA125 20 mm – 60 mm	 PASE..-XL-N-FA125
GE..-XL-KRR-B-FA125 20 mm – 50 mm	 RASE..-XL-N-FA125
SUC 12 mm – 30 mm	 Available by agreement

Catalogue range; other dimensions and combinations available by agreement.

Further information: SG 1 ► <https://www.schaeffler.de/std/1D60>

Housing selection wizard: ► <https://www.schaeffler.de/std/1D61>

¹⁾ With Corrotect coating.

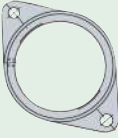
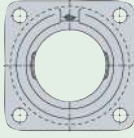
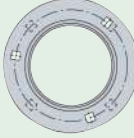
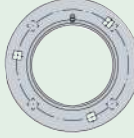
		Sheet steel housing ¹⁾	
Two-bolt flanged housing	Four-bolt flanged housing	Three-bolt flanged housing	
			
CJT	CJ	FLAN..-MSB-VA (2 pieces)	FLAN..-MSA-VA FLAN..-MSB-VA
PCJT..-XL-N-FA125	PCJ..-XL-N-FA125	Available by agreement	Available by agreement
RCJT..-XL-N-FA125	RCJ..-XL-N-FA125	Available by agreement	Available by agreement
Available by agreement	Available by agreement	RRY..-VA	GRRY..-VA





27
*Possible combinations
of radial insert ball bearings
with plastic housings*

Radial insert ball bearing	Plastic housing	
	Plummer block housing	
Designation	GEHPP	GEHPPA
Shaft diameter d		
SUB 20 mm – 50 mm		SUBPP SUBPPA
SUC 20 mm – 50 mm		SUCPP SUCPPA
SUG 20 mm – 50 mm		SUGPP SUGPPA
GRAE..-XL-NPP-B-FA107/125 20 mm – 50 mm		CUGPP CUGPPA

Catalogue range; other dimensions and combinations available by agreement.

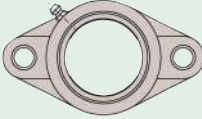

Further information: SG 1 ► <https://www.schaeffler.de/std/1D60>

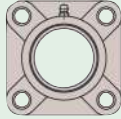
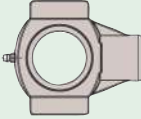
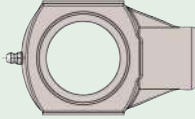
 Combinations not possible or not advisable.

Two-bolt flanged housing		Four-bolt flanged housing	Take-up housing	
				
GEHPFL	GEHPCTL	GEHPF	GEHPT	GEHPHE
SUBPFL	SUBPCTL	SUBPF	SUBPT	SUBPHE
SUCPFL		SUCPF	SUCPT	SUCPHE
SUGPFL	SUGPCTL	SUGPF	SUGPT	SUGPHE
CUGPFL	CUGPCTL	CUGPF	CUGPT	CUGPHE

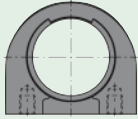

28
Possible combinations
of JIS radial insert ball bearings
with JIS housings (Black Series)

Radial insert ball bearing ¹⁾	Cast iron housing ¹⁾	
	Plummer block housing	
		
Designation	P	PA
Shaft diameter d		
UC 12 mm – 90 mm 1/2" – 3 1/2"		UCP
UK 20 mm – 80 mm		UKP
		Available by agreement

Catalogue range; other dimensions and combinations available by agreement.
Further information: SG 1 ► <https://www.schaeffler.de/std/1D60>

¹⁾ With Durotect BS coating

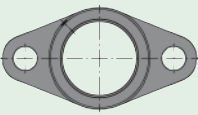
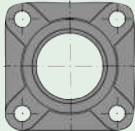
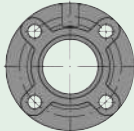
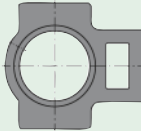
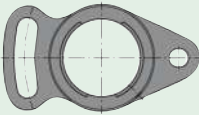
Two-bolt flanged housing	Four-bolt flanged housing		Take-up housing	
				
FL	F	FC	T	FA
UCFL	UCF	UCFC	UCT	UCFA
UKFL	UKF	UKFC	UKT	Available by agreement



1.17 Mounting and dismounting



The detailed guidelines on the mounting and dismounting of radial insert ball bearings must be observed. These can be found in Catalogue
 ▶ □ SG 1, Radial Insert Ball Bearings and Housing Units
 ▶ <https://www.schaeffler.de/std/1D60>.

Tightening torques for grub screws

The tightening torques for metric and inch size grub screws from Schaeffler are dependent on the material of the screws ▶ 1504 | □ 29 and ▶ 1504 | □ 30. The tightening torques are valid only for original grub screws from Schaeffler (INA or FAG brand).

41
Fully tightening the grub screws or locknut in the inner ring

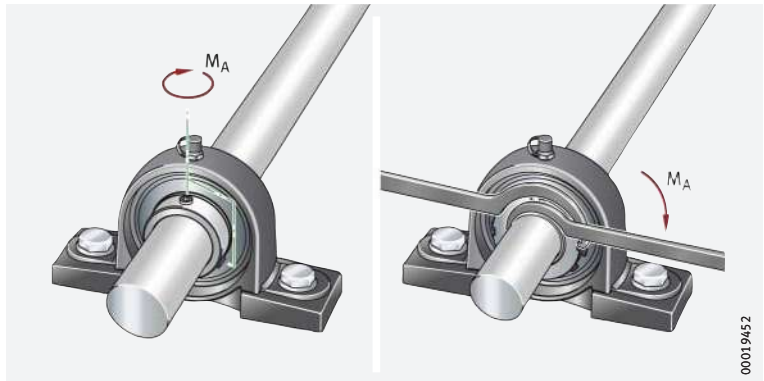

29
Tightening torques for standard grub screws

Width across flats W		Thread		Tightening torque ¹⁾ M _A
mm	inch	ISO	UNF	Nm
2,5	3/32	M5	N10-32	3,6
3	1/8	M6×0,75	1/4"-28	6
4	5/32	M8×1	5/16"-24	14
5	3/16	M10×1,25	3/8"-24	26
6	1/4	M12×1,5 M12×1,25 ²⁾	1/2"-20	42

¹⁾ Grub screws from Schaeffler.

²⁾ GYE90-KRR-B.

30
Tightening torques for metric grub screws, corrosion-resistant VA design

Width across flats W mm	Thread	Tightening torque ¹⁾ M _A Nm
2,5	M5	2,4
3	M6×0,75	3,9
4	M8×1	8,3
5	M10×1,25	16

¹⁾ High grade steel grub screws from Schaeffler.

Tightening torques for locknuts

The tightening torques for the locknuts differ between the two brands INA and FAG ► 1505 |  31 and ► 1505 |  32.

 **31**
Hook wrenches and
tightening torques
for radial insert ball bearings
of the INA brand

Shaft diameter d mm	Hook wrench, type A to DIN 1810		Tightening torque Locknut	
	for tightening of locknut	for countertensioning of adapter sleeve	M _A min. Nm	max. Nm
20	A 30–32 (HN 4)	A 25–28 (HN 2)	13	17
25	A 40–42 (HN 5)	A 30–32 (HN 3)	22	28
30	A 45–50 (HN 6)	A 34–36 (HN 4)	33	40
35	A 52–55 (HN 7)	A 40–42 (HN 5)	47	56
40	A 58–62 (HN 8)	A 45–50 (HN 6)	70	80
50	A 68–75 (HN 10)	A 52–55 (HN 7)	90	105

 **32**
Tightening torques for locknuts,
Black Series, FAG brand

Shaft d mm	Locknut	Tightening torque M _A ± 5% Nm
20	AN05	25
25	AN06	30
30	AN07	40
35	AN08	50
40	AN09	60
45	AN10	75
50	AN11	100
55	AN12	130
60	AN13	150
65	AN15	170
70	AN16	200
75	AN17	230
80	AN18	270

1.18

Legal notice regarding data freshness



 *The further development of products may also result in technical changes to catalogue products*

Of central interest to Schaeffler is the further development and optimisation of its products and the satisfaction of its customers. In order that you, as the customer, can keep yourself optimally informed about the progress that is being made here and with regard to the current technical status of the products, we publish any product changes which differ from the printed version in our electronic product catalogue.



We therefore reserve the right to make changes to the data and illustrations in this catalogue. This catalogue reflects the status at the time of printing. More recent publications released by us (as printed or digital media) will automatically precede this catalogue if they involve the same subject. Therefore, please always use our electronic product catalogue to check whether more up-to-date information or modification notices exist for your desired product.

Link to electronic product catalogue



The following link will take you to the Schaeffler electronic product catalogue: ► <https://medias.schaeffler.com>.

1.19 Further information

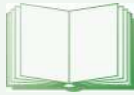

In addition to the data in this chapter, the following chapters in Technical principles must also be observed in the design of bearing arrangements:

- Determining the bearing size ▶ 34
- Rigidity ▶ 54
- Friction and increases in temperature ▶ 56
- Speeds ▶ 64
- Bearing data ▶ 97
- Lubrication ▶ 70
- Sealing ▶ 182
- Design of bearing arrangements ▶ 139
- Mounting and dismounting ▶ 191.

The complete catalogue range of the available radial insert ball bearings and housing units, together with all the technical principles, descriptions and product tables, is presented in Catalogue SG 1, Radial Insert Ball Bearings and Housing Units.

- Download and ordering
▶ <https://www.schaeffler.de/std/1D60>
- Electronic information system
▶ <https://www.schaeffler.de/std/1D62>
- Housing selection wizard
▶ <https://www.schaeffler.de/std/1D61>





Radial insert ball bearings with eccentric locking collar

Spherical outside surface of outer ring

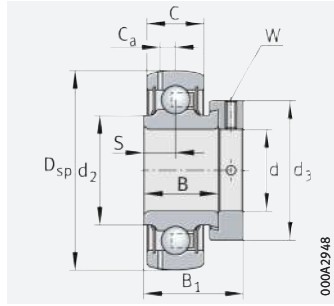

GRAE..-XL-NPP-B

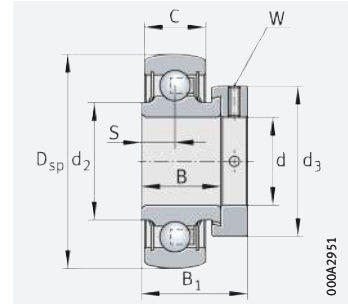

RAE..-XL-NPP-B, RALE..-XL-NPP-B

d = 12 – 25 mm

Main dimensions				Basic load ratings		Fatigue limit load	Factor ¹⁾	Mass	Designation ²⁾
d	D _{sp}	B ₁	d ₃	dyn. C _r	stat. C _{0r}	C _{ur}	f ₀	m	
			max.	N	N	N		≈ kg	▶ 1485 1.12 ▶ 1486 1.13 X-life ▶ 1453
12	40	28,6	28,4	10 100	4 750	241	13,1	0,13	GRAE12-XL-NPP-B
	40	28,6	28,4	10 100	4 750	241	13,1	0,13	RAE12-XL-NPP-B
15	40	28,6	28,4	10 100	4 750	241	13,1	0,11	GRAE15-XL-NPP-B
	40	28,6	28,4	10 100	4 750	241	13,1	0,12	RAE15-XL-NPP-B
17	40	37,4	28,4	10 100	4 750	241	13,1	0,12	GE17-XL-KRR-B
	40	28,6	28,4	10 100	4 750	241	13,1	0,12	GRAE17-XL-NPP-B
	40	28,6	28,4	10 100	4 750	241	13,1	0,1	RAE17-XL-NPP-B
20	47	43,7	33	13 600	6 600	335	13,1	0,2	GE20-XL-KLL-B
	47	43,7	33	13 600	6 600	335	13,1	0,19	GE20-XL-KRR-B
	47	43,7	33	13 600	6 600	335	13,1	0,2	GE20-XL-KRR-B-FA164
	47	43,7	33	13 600	6 600	335	13,1	0,19	GE20-XL-KTT-B
	47	31	33	13 600	6 600	335	13,1	0,16	GRAE20-XL-NPP-B
	47	31	33	13 600	6 600	335	13,1	0,16	RAE20-XL-NPP-B
	42	24,5	30	10 000	5 000	255	13,9	0,1	RALE20-XL-NPP-B
25	52	44,5	37,5	14 900	7 800	395	13,8	0,24	E25-XL-KRR-B
	52	44,5	37,5	14 900	7 800	395	13,8	0,25	GE25-XL-KRR-B
	52	44,5	37,5	14 900	7 800	395	13,8	0,24	GE25-XL-KRR-B-FA101
	52	44,5	37,5	14 900	7 800	395	13,8	0,25	GE25-XL-KRR-B-FA164
	52	44,5	37,5	14 900	7 800	395	13,8	0,25	GE25-XL-KLL-B
	52	44,5	37,5	14 900	7 800	395	13,8	0,24	GE25-XL-KTT-B
	52	44,5	37,5	14 900	7 800	395	13,8	0,26	GE25-XL-KRR-B-2C
	52	31	37,5	14 900	7 800	395	13,8	0,19	GRAE25-XL-NPP-B
	52	31	37,5	14 900	7 800	395	13,8	0,19	RAE25-XL-NPP-B
	47	25,5	36	10 700	5 900	295	13,8	0,12	RALE25-XL-NPP-B

medias ▶ <https://www.schaeffler.de/std/1DD0>

- 1) Factor f₀ for determining equivalent bearing load ▶ 1489 | 22.
- 2) Permissible speeds of radial insert ball bearings ▶ 1476.

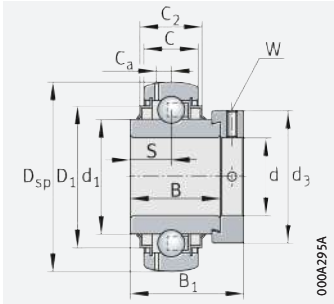

GE..-XL-KRR-B

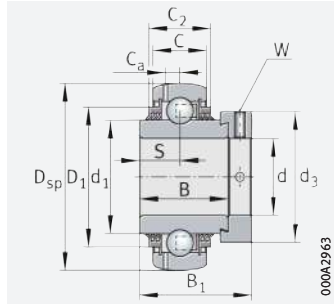

GE..-XL-KTT-B

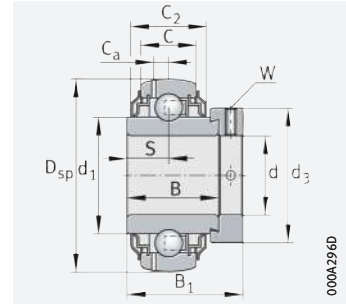

GE..-XL-KRR-B-2C

Dimensions										Width across flats
d	C	C ₂	B	S	d ₁	d ₂	D ₁	C _a	W	
12	12	-	19	6,5	-	23	-	3,4	3	
	12	-	19	6,5	-	23	-	-	3	
15	12	-	19	6,5	-	23	-	3,4	3	
	12	-	19	6,5	-	23	-	-	3	
17	12	16,6	27,8	13,9	23,9	-	31,6	3,4	3	
	12	-	19	6,5	-	23	-	3,4	3	
	12	-	19	6,5	-	23	-	-	3	
20	14	16,6	34,1	17,1	27,6	-	37,4	4	3	
	14	16,6	34,1	17,1	27,6	-	37,4	4	3	
	14	16,6	34,1	17,1	27,6	-	37,4	4	3	
	14	16,6	34,1	17,1	27,6	-	37,4	4	3	
	14	-	21,4	7,5	-	26,9	-	4	3	
	14	-	21,4	7,5	-	26,9	-	-	3	
	12	-	16,7	6	-	25,4	-	-	2,5	
25	15	16,7	34,9	17,5	33,8	-	42,5	-	3	
	15	16,7	34,9	17,5	33,8	-	42,5	4,1	3	
	15	16,7	34,9	17,5	33,8	-	42,5	4,1	3	
	15	16,7	34,9	17,5	33,8	-	42,5	4,1	3	
	15	20,2	34,9	17,5	33,8	-	42,5	4,1	3	
	15	20,2	34,9	17,5	33,8	-	42,5	4,1	3	
	15	24,6	34,9	17,5	33,8	-	42,5	4,1	3	
	15	-	21,4	7,5	-	30,5	-	4,1	3	
	15	-	21,4	7,5	-	30,5	-	-	3	
	12	-	17,5	6	-	30	-	-	2,5	

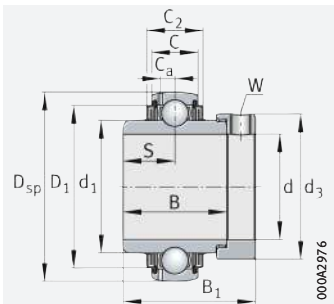

GE..-XL-KLL-B

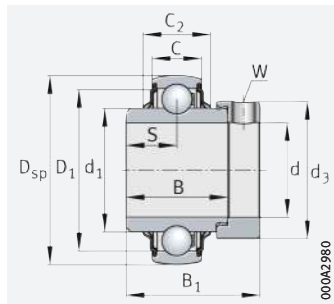

E..-XL-KRR-B

Radial insert ball bearings with eccentric locking collar

Spherical outside surface of outer ring

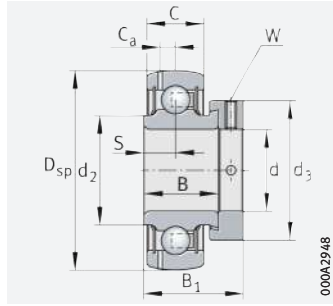

GRAE..-XL-NPP-B

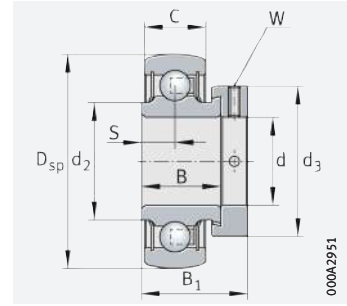

RAE..-XL-NPP-B, RALE..-XL-NPP-B

d = 30 – 35 mm

Main dimensions				Basic load ratings		Fatigue limit load	Factor ¹⁾	Mass	Designation ²⁾
d	D _{sp}	B ₁	d ₃	dyn. C _r	stat. C _{0r}	C _{ur}	f ₀	m	
			max.	N	N	N		≈ kg	▶ 1485 1.12 ▶ 1486 1.13 X-life ▶ 1453
30	62	48,5	44	20 700	11 300	570	13,8	0,39	GE30-XL-KLL-B
	62	48,5	44	20 700	11 300	570	13,8	0,39	E30-XL-KRR-B
	62	48,5	44	20 700	11 300	570	13,8	0,39	GE30-XL-KRR-B
	62	48,5	44	20 700	11 300	570	13,8	0,38	GE30-XL-KRR-B-FA101
	62	48,5	44	20 700	11 300	570	13,8	0,39	GE30-XL-KRR-B-FA164
	62	48,5	44	20 700	11 300	570	13,8	0,38	GE30-XL-KTT-B
	72	50,2	51	31 500	16 700	840	13	0,63	GNE30-XL-KRR-B
	62	48,5	44	20 700	11 300	570	13,8	0,41	GE30-XL-KRR-B-2C
	62	35,8	44	20 700	11 300	570	13,8	0,32	GRAE30-XL-NPP-B
	62	35,8	44	20 700	11 300	570	13,8	0,32	RAE30-XL-NPP-B
35	55	26,5	42,5	14 100	8 300	420	13,8	0,18	RALE30-XL-NPP-B
	72	51,3	55	27 500	15 300	770	13,8	0,59	E35-XL-KRR-B
	72	51,3	55	27 500	15 300	770	13,8	0,59	GE35-XL-KRR-B
	72	51,3	55	27 500	15 300	770	13,8	0,61	GE35-XL-KRR-B-FA164
	72	51,3	55	27 500	15 300	770	13,8	0,59	GE35-XL-KTT-B
	80	51,6	55	39 000	20 900	1 060	13,1	0,74	GNE35-XL-KRR-B
	72	51,3	55	27 500	15 300	770	13,8	0,6	GE35-XL-KLL-B
	72	51,3	55	27 500	15 300	770	13,8	0,63	GE35-XL-KRR-B-2C
	72	39	55	27 500	15 300	770	13,8	0,52	GRAE35-XL-NPP-B
	72	39	55	27 500	15 300	770	13,8	0,52	RAE35-XL-NPP-B

medias ▶ <https://www.schaeffler.de/std/1DD1>

1) Factor f₀ for determining equivalent bearing load ▶ 1489 | 22.

2) Permissible speeds of radial insert ball bearings ▶ 1476.

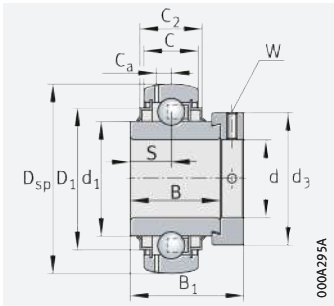

GE..-XL-KRR-B, GNE..-XL-KRR-B

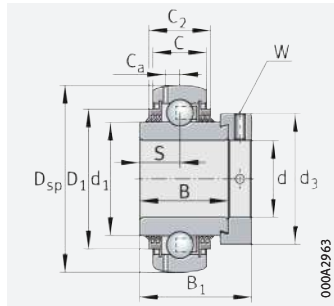

GE..-XL-KTT-B

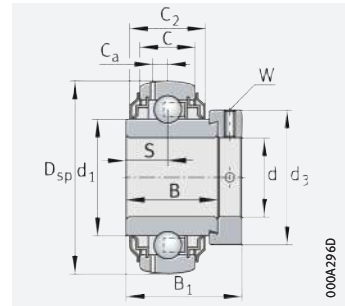

GE..-XL-KRR-B-2C

Dimensions

d	C	C ₂	B	S	d ₁	d ₂	D ₁	C _a	Width across flats W
30	18	20,6	36,5	18,3	40,2	–	52	4,7	4
	18	20,7	36,5	18,3	40,2	–	52	–	4
	18	20,7	36,5	18,3	40,2	–	52	4,7	4
	18	20,7	36,5	18,3	40,2	–	52	4,7	4
	18	20,7	36,5	18,3	40,2	–	52	4,7	4
	18	20,7	36,5	18,3	40,2	–	52	4,7	4
	20	24	36,6	17,5	44	–	60,2	6,2	5
	18	27,2	36,5	18,3	40,2	–	–	4,7	4
	18	–	23,8	9	–	37,4	–	4,7	4
	18	–	23,8	9	–	37,4	–	–	4
13	–	18,5	6,5	–	35,7	–	–	2,5	
35	19	22,5	37,7	18,8	46,8	–	60,3	–	5
	19	22,5	37,7	18,8	46,8	–	60,3	5,6	5
	19	22,5	37,7	18,8	46,8	–	60,3	5,6	5
	19	22,5	37,7	18,8	46,8	–	60,3	5,6	5
	22	25	38,1	18,3	48	–	66,6	6,9	5
	19	25,4	37,7	18,8	46,8	–	60,3	5,6	5
	19	29,2	37,7	18,8	46,8	–	–	5,6	5
	19	–	25,4	9,5	–	44,6	–	5,6	5
	19	–	25,4	9,5	–	44,6	–	–	5

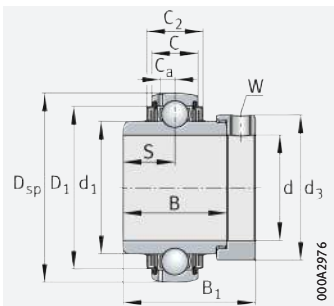

GE..-XL-KLL-B

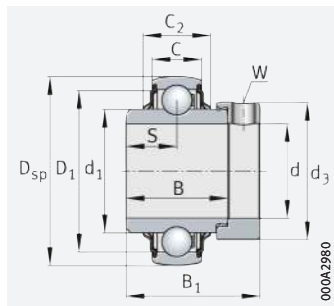

E..-XL-KRR-B

Radial insert ball bearings with eccentric locking collar

Spherical outside surface of outer ring

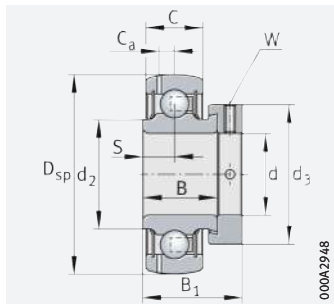

GRAE..-XL-NPP-B

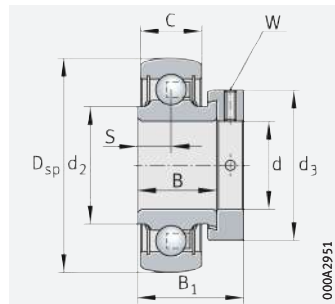

RAE..-XL-NPP-B

d = 40 – 50 mm

Main dimensions				Basic load ratings		Fatigue limit load	Factor ¹⁾	Mass	Designation ²⁾
d	D _{sp}	B ₁	d ₃	dyn. C _r	stat. C _{0r}	C _{ur}	f ₀	m	
			max.	N	N	N		≈ kg	▶ 1485 1.12 ▶ 1486 1.13 X-life ▶ 1453
40	80	56,5	58	34 500	19 800	1 010	14	0,73	E40-XL-KRR-B
	80	56,5	58	34 500	19 800	1 010	14	0,73	GE40-XL-KRR-B
	80	56,5	58	34 500	19 800	1 010	14	0,74	GE40-XL-KRR-B-FA101
	80	56,5	58	34 500	19 800	1 010	14	0,75	GE40-XL-KRR-B-FA164
	90	54,6	63	47 000	26 000	1 320	13	1,02	GNE40-XL-KRR-B
	80	56,5	58	34 500	19 800	1 010	14	0,75	GE40-XL-KLL-B
	80	56,5	58	34 500	19 800	1 010	14	0,75	GE40-XL-KTT-B
	80	56,5	58	34 500	19 800	1 010	14	0,78	GE40-XL-KRR-B-2C
	80	43,8	58	34 500	19 800	1 010	14	0,62	GRAE40-XL-NPP-B
	80	43,8	58	34 500	19 800	1 010	14	0,63	RAE40-XL-NPP-B
45	85	56,5	63	34 500	20 400	1 030	14,3	0,84	GE45-XL-KLL-B
	85	56,5	63	34 500	20 400	1 030	14,3	0,83	GE45-XL-KRR-B
	85	56,5	63	34 500	20 400	1 030	14,3	0,83	GE45-XL-KTT-B
	85	43,8	63	34 500	20 400	1 030	14,3	0,7	GRAE45-XL-NPP-B
50	90	62,8	69	37 500	23 200	1 180	14,3	1	GE50-XL-KLL-B
	90	62,8	69	37 500	23 200	1 180	14,3	0,99	GE50-XL-KRR-B
	90	62,8	69	37 500	23 200	1 180	14,3	0,99	GE50-XL-KRR-B-FA101
	90	62,8	69	37 500	23 200	1 180	14,3	0,99	GE50-XL-KRR-B-FA164
	90	62,8	69	37 500	23 200	1 180	14,3	0,98	GE50-XL-KTT-B
	110	66,75	75,8	66 000	38 000	1 920	13	1,82	GNE50-XL-KRR-B
	90	43,8	69	37 500	23 200	1 180	14,3	0,77	GRAE50-XL-NPP-B
	110	66,75	75,8	66 000	38 000	1 920	13	1,82	NE50-XL-KRR-B³⁾
	90	43,8	69	37 500	23 200	1 180	14,3	0,77	RAE50-XL-NPP-B

medias ▶ <https://www.schaeffler.de/std/1DD2>

1) Factor f₀ for determining equivalent bearing load ▶ 1489 | 22.

2) Permissible speeds of radial insert ball bearings ▶ 1476.

3) No relubrication facility.

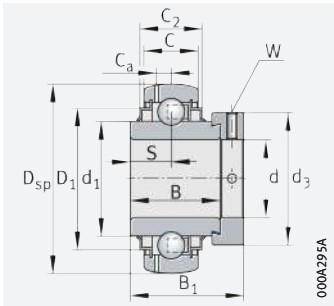

GE..-XL-KRR-B, GNE..-XL-KRR-B

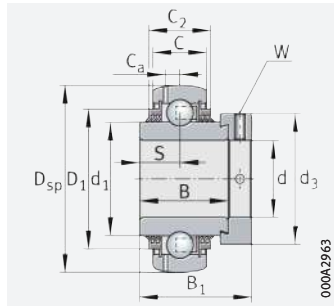

GE..-XL-KTT-B

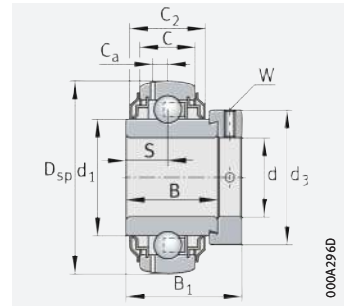

GE..-XL-KRR-B-2C

Dimensions										Width across flats
d	C	C ₂	B	S	d ₁	d ₂	D ₁	C _a	W	
40	21	23,5	42,9	21,4	52,3	–	68,3	–	5	
	21	23,5	42,9	21,4	52,3	–	68,3	6,4	5	
	21	23,5	42,9	21,4	52,3	–	68,3	6,4	5	
	21	23,5	42,9	21,4	52,3	–	68,3	6,4	5	
	23	26	41	18	53,8	–	74,5	7,5	5	
	21	28,1	42,9	21,4	52,3	–	68,3	6,4	5	
	21	28,1	42,9	21,4	52,3	–	68,3	6,4	5	
	21	31,9	42,9	21,4	52,3	–	–	6,4	5	
	21	–	30,2	11	–	49,4	–	6,4	5	
	21	–	30,2	11	–	49,4	–	–	5	
45	22	26,4	42,9	21,4	57,9	–	72,3	6,4	5	
	22	26,4	42,9	21,4	57,9	–	72,3	6,4	5	
	22	26,4	42,9	21,4	57,9	–	72,3	6,4	5	
	22	–	30,2	11	–	54,3	–	6,4	5	
50	22	26,4	49,2	24,6	62,8	–	77,3	6,9	5	
	22	26,4	49,2	24,6	62,8	–	77,3	6,9	5	
	22	26,4	49,2	24,6	62,8	–	77,3	6,9	5	
	22	26,4	49,2	24,6	62,8	–	77,3	6,9	5	
	22	26,4	49,2	24,6	62,8	–	77,3	6,9	5	
	29	–	49,2	24,6	68,8	–	92,7	8,7	5	
	22	–	30,2	11	–	59,4	–	6,9	5	
	29	–	49,2	24,6	68,8	–	–	–	5	
	22	–	30,2	11	–	59,4	–	–	5	

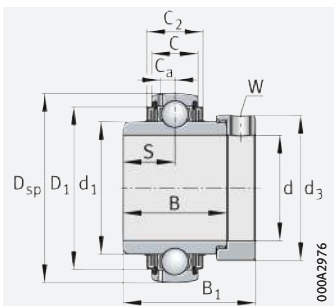

GE..-XL-KLL-B

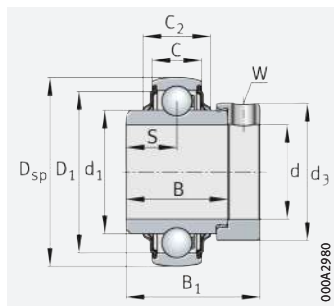

E..-XL-KRR-B, NE..-XL-KRR-B

Radial insert ball bearings with eccentric locking collar

Spherical outside surface of outer ring

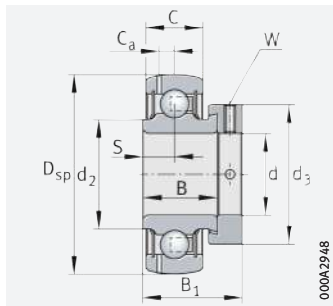

GRAE..-XL-NPP-B

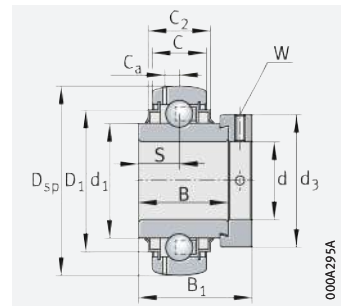

GE..-XL-KRR-B, GNE..-XL-KRR-B

d = 55 – 120 mm

Main dimensions				Basic load ratings		Fatigue limit load	Factor ¹⁾	Mass	Designation ²⁾
d	D _{sp}	B ₁	d ₃	dyn. C _r	stat. C _{0r}	C _{ur}	f ₀	m	
			max.	N	N	N		≈ kg	► 1485 1.12 ► 1486 1.13 X-life ► 1453
55	100	71,4	76	46 000	29 000	1 480	14,3	1,37	GE55-XL-KRR-B
	100	71,4	76	46 000	29 000	1 480	14,3	1,37	GE55-XL-KTT-B
	100	48,4	76	46 000	29 000	1 480	14,3	1,06	GRAE55-XL-NPP-B
60	110	77,9	84	56 000	36 000	1 820	14,3	1,8	GE60-XL-KRR-B
	110	77,9	84	56 000	36 000	1 820	14,3	1,8	GE60-XL-KRR-B-FA101
	110	77,9	84	56 000	36 000	1 820	14,3	1,8	GE60-XL-KRR-B-FA164
	110	77,9	84	56 000	36 000	1 820	14,3	1,8	GE60-XL-KTT-B
	130	68	89	87 000	52 000	2 650	13,1	2,97	GNE60-XL-KRR-B
	110	53,1	84	56 000	36 000	1 820	14,3	1,4	GRAE60-XL-NPP-B
65	125	66	96	66 000	44 000	2 230	14,4	2,71	GE65-214-XL-KRR-B ³⁾
	125	66	96	66 000	44 000	2 230	14,4	2,71	GE65-214-XL-KRR-B-FA164 ³⁾
	125	66	96	66 000	44 000	2 230	14,4	2,71	GE65-214-XL-KTT-B ³⁾
70	125	66	96	66 000	44 000	2 230	14,4	2,15	GE70-XL-KRR-B
	125	66	96	66 000	44 000	2 230	14,4	2,15	GE70-XL-KRR-B-FA101
	125	66	96	66 000	44 000	2 230	14,4	2,15	GE70-XL-KRR-B-FA164
	125	66	96	66 000	44 000	2 230	14,4	2,15	GE70-XL-KTT-B
	150	75,5	102	111 000	68 000	3 300	13,2	3,81	GNE70-XL-KRR-B
75	130	67	100	66 000	44 500	2 240	14,4	2,14	GE75-XL-KRR-B
	130	67	100	66 000	44 500	2 240	14,4	2,14	GE75-XL-KRR-B-FA101
	130	67	100	66 000	44 500	2 240	14,4	2,14	GE75-XL-KTT-B
80	140	70,7	108	76 000	54 000	2 600	14,6	2,79	GE80-XL-KRR-B
	140	70,7	108	76 000	54 000	2 600	14,6	2,95	GE80-XL-KRR-B-AH01-FA164
	140	70,7	108	76 000	54 000	2 600	14,6	2,79	GE80-XL-KTT-B
	170	93,6	118	131 000	87 000	3 950	13,2	7,1	GNE80-XL-KRR-B ⁴⁾
90	160	69,5	118	109 000	79 000	3 550	14,5	3,56	GE90-XL-KRR-B ⁴⁾
	160	69,5	118	109 000	79 000	3 550	14,5	3,68	GE90-XL-KRR-B-FA164 ⁴⁾
	190	101	132	151 000	107 000	4 600	13,9	8,07	GNE90-XL-KRR-B ⁴⁾
100	180	75	132	130 000	93 000	4 000	14,4	5	GE100-XL-KRR-B ⁴⁾
	215	109,4	145	184 000	141 000	5 700	13,8	11,41	GNE100-XL-KRR-B ⁴⁾
120	215	81	152	165 000	131 000	5 100	14,8	7,49	GE120-XL-KRR-B ⁴⁾

medias ► <https://www.schaeffler.de/std/1DD3>

- Factor f₀ for determining equivalent bearing load ► 1489 | 22.
- Permissible speeds of radial insert ball bearings ► 1476.
- Alternative ball set 6214.
- Lubrication groove in outer ring.

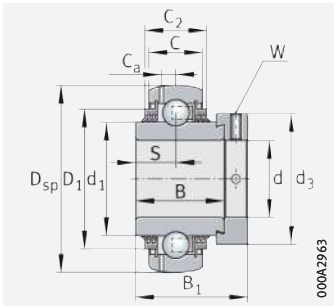

GE..-XL-KTT-B

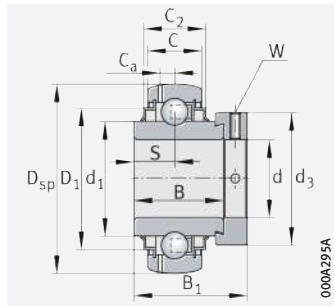

GNE..-XL-KRR-B

Dimensions										Width across flats
d	C	C ₂	B	S	d ₁	d ₂	D ₁	C _a	W	
55	25	29	55,5	27,8	69,8	–	85,9	7	5	
	25	29	55,5	27,8	69,8	–	85,9	7	5	
	25	–	32,5	12	–	66	–	7	5	
60	24	29	61,9	31	76,5	–	94,5	7,2	5	
	24	29	61,9	31	76,5	–	94,5	7,2	5	
	24	29	61,9	31	76,5	–	94,5	7,2	5	
	24	29	61,9	31	76,5	–	94,5	7,2	5	
	33	37,2	52	23	79,4	–	109	11,2	5	
	24	–	37,1	13,5	–	72	–	7,2	5	
65	28	32	48,5	21,5	85,2	–	109	8,9	6	
	28	32	48,5	21,5	85,2	–	109	8,9	6	
	28	32	48,5	21,5	85,2	–	109	8,9	6	
70	28	32	48,5	21,5	85,2	–	109	8,9	6	
	28	32	48,5	21,5	85,2	–	109	8,9	6	
	28	32	48,5	21,5	85,2	–	109	8,9	6	
	28	32	48,5	21,5	85,2	–	109	8,9	6	
	28	32	48,5	21,5	85,2	–	109	8,9	6	
	37	41	58	26	92,2	–	127	12	6	
75	28	30,5	49,5	21,5	90	–	113	8,5	6	
	28	30,5	49,5	21,5	90	–	113	8,5	6	
	28	30,5	49,5	21,5	90	–	113	8,5	6	
80	30	38	53,2	23,4	97	–	120	8,8	6	
	30	38	53,2	23,4	97	–	120	8,8	6	
	30	38	53,2	23,4	97	–	120	8,8	6	
	41	51	73	34	109	–	142,8	13,2	6	
90	32	35	52	23	109,4	–	138	10	6	
	32	35	52	23	109,4	–	138	10	6	
	45	52,6	77,5	35,5	122,2	–	161,3	14,3	6	
100	36	39	57,5	25,5	122,2	–	155,5	11,2	6	
	49	59,4	86	39,5	137,1	–	182,8	16,7	6	
120	40	45	63,5	28,5	146,4	–	186,5	12,8	6	





Radial insert ball bearings with eccentric locking collar

Cylindrical outside surface of outer ring

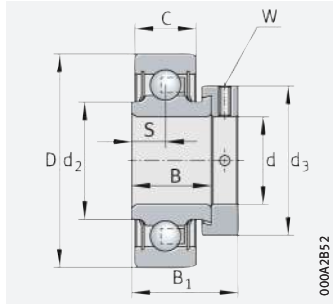

RAE..-XL-NPP-FA106, RALE..-XL-NPP

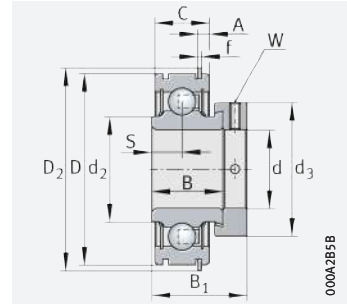

RAE..-XL-NPP-NR

d = 12 – 30 mm

Main dimensions				Basic load ratings		Fatigue limit load	Factor ¹⁾	Mass	Designation ²⁾
d	D	B ₁	d ₃	dyn. C _r	stat. C _{0r}	C _{ur}	f ₀	m	
			max.	N	N	N		≈ kg	
12	40	28,6	28,4	10 100	4 750	241	13,1	0,13	RAE12-XL-NPP-FA106
15	40	28,6	28,4	10 100	4 750	241	13,1	0,12	RAE15-XL-NPP-FA106
17	40	28,6	28,4	10 100	4 750	241	13,1	0,11	RAE17-XL-NPP-FA106
20	42	24,5	30	10 000	5 000	255	13,9	0,1	RALE20-XL-NPP-FA106
	47	31	33	13 600	6 600	335	13,1	0,17	RAE20-XL-NPP-FA106
	47	31	33	13 600	6 600	335	13,1	0,17	RAE20-XL-NPP-NR
	47	43,7	33	13 600	6 600	335	13,1	0,2	E20-XL-KLL
	47	43,7	33	13 600	6 600	335	13,1	0,2	E20-XL-KRR
25	47	25,5	36	10 700	5 900	295	14,5	0,13	RALE25-XL-NPP
	52	31	37,5	14 900	7 800	395	13,8	0,2	RAE25-XL-NPP-FA106
	52	31	37,5	14 900	7 800	395	13,8	0,2	RAE25-XL-NPP-NR
	52	44,5	37,5	14 900	7 800	395	13,8	0,25	E25-XL-KLL
	52	44,5	37,5	14 900	7 800	395	13,8	0,25	E25-XL-KRR
30	55	26,5	42,5	14 100	8 300	420	14,8	0,18	RALE30-XL-NPP-FA106
	62	35,8	44	20 700	11 300	570	13,8	0,33	RAE30-XL-NPP-FA106
	62	35,8	44	20 700	11 300	570	13,8	0,33	RAE30-XL-NPP-NR
	62	48,5	44	20 700	11 300	570	13,8	0,39	E30-XL-KLL
	62	48,5	44	20 700	11 300	570	13,8	0,4	E30-XL-KRR

medias ► <https://www.schaeffler.de/std/1DD4>

1) Factor f₀ for determining equivalent bearing load ► 1489 | 22.

2) Permissible speeds of radial insert ball bearings ► 1476.

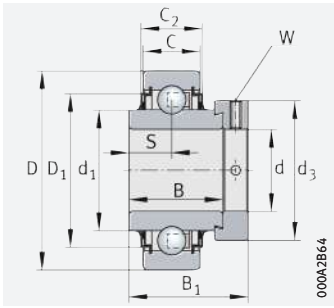

E..-XL-KLL

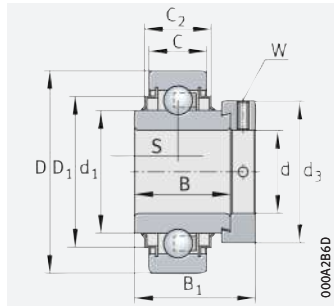

E..-XL-KRR

Dimensions

d	D ₂	C	C ₂	A	f	B	S	d ₁	d ₂	D ₁	Width across flats W
12	-	12	-	-	-	19	6,5	-	23	-	3
15	-	12	-	-	-	19	6,5	-	23	-	3
17	-	12	-	-	-	19	6,5	-	23	-	3
20	-	12	-	-	-	16,7	6	-	25,4	-	2,5
	-	14	-	-	-	21,4	7,5	-	26,9	-	3
	52,7	14	-	3,58 0 -0,25	1,12 0 -0,1	21,4	7,5	-	26,9	-	3
	-	14	16,6	-	-	34,1	17,1	27,6	-	37,4	3
	-	14	16,6	-	-	34,1	17,1	27,6	-	37,4	3
25	-	12	-	-	-	17,5	6	-	30	-	2,5
	-	15	-	-	-	21,4	7,5	-	30,5	-	3
	57,9	15	-	3,58 0 -0,25	1,12 0 -0,1	21,4	7,5	-	30,5	-	3
	-	15	20,2	-	-	34,9	17,5	33,8	-	42,5	3
	-	15	16,7	-	-	34,9	17,5	33,8	-	42,5	3
30	-	13	-	-	-	18,5	6,5	-	35,7	-	2,5
	-	18	-	-	-	23,8	9	-	37,4	-	4
	67,7	18	-	4,98 0 -0,3	1,7 0 -0,1	23,8	9	-	37,4	-	4
	-	18	20,6	-	-	36,5	18,3	40,2	-	52	4
	-	18	20,7	-	-	36,5	18,3	40,2	-	52	4





Radial insert ball bearings with eccentric locking collar

Cylindrical outside surface of outer ring

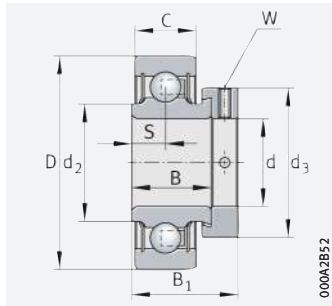

RAE..-XL-NPP(-FA106), RALE..-XL-NPP

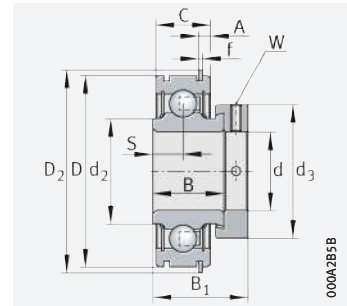

RAE..-XL-NPP-NR

d = 35 – 70 mm

Main dimensions				Basic load ratings		Fatigue limit load		Factor ¹⁾	Mass	Designation ²⁾
d	D	B ₁	d ₃	dyn. C _r	stat. C _{0r}	C _{ur}	f ₀	m		
			max.	N	N	N		≈ kg		
35	72	39	55	27 500	15 300	770	13,8	0,54	RAE35-XL-NPP-FA106	
	72	39	55	27 500	15 300	770	13,8	0,53	RAE35-XL-NPP-NR	
	72	51,3	55	27 500	15 300	770	13,8	0,6	E35-XL-KLL	
	72	51,3	55	27 500	15 300	770	13,8	0,61	E35-XL-KRR	
40	80	43,8	58	34 500	19 800	1 010	14	0,64	RAE40-XL-NPP-FA106	
	80	43,8	58	34 500	19 800	1 010	14	0,64	RAE40-XL-NPP-NR	
	80	56,5	58	34 500	19 800	1 010	14	0,76	E40-XL-KLL	
	80	56,5	58	34 500	19 800	1 010	14	0,75	E40-XL-KRR	
45	85	43,8	63	34 500	20 400	1 030	14,3	0,72	RAE45-XL-NPP-FA106	
	85	56,5	63	34 500	20 400	1 030	14,3	0,85	E45-XL-KLL	
	85	56,5	63	34 500	20 400	1 030	14,3	0,85	E45-XL-KRR	
50	90	43,8	69	37 500	23 200	1 180	14,3	0,79	RAE50-XL-NPP-FA106	
	90	62,8	69	37 500	23 200	1 180	14,3	1	E50-XL-KLL	
	90	62,8	69	37 500	23 200	1 180	14,3	1	E50-XL-KRR	
60	110	53,1	84	56 000	36 000	1 820	14,3	1,43	RAE60-XL-NPP	
	110	77,9	84	56 000	36 000	1 820	14,3	1,82	E60-XL-KRR	
70	125	66	96	66 000	44 000	2 230	14,4	2,45	E70-XL-KRR	

medias ► <https://www.schaeffler.de/std/1DD5>

1) Factor f₀ for determining equivalent bearing load ► 1489 | 22.

2) Permissible speeds of radial insert ball bearings ► 1476.

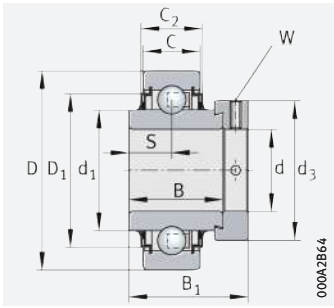

E..-XL-KLL

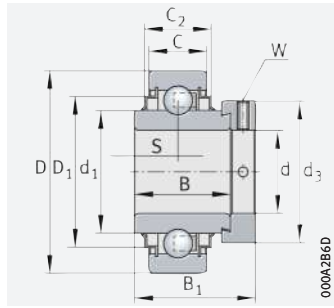

E..-XL-KRR

Dimensions

d	D ₂	C	C ₂	A	f	B	S	d ₁	d ₂	D ₁	Width across flats W
35	–	19	–	–	–	25,4	9,5	–	44,6	–	5
	78,6	19	–	4,98 ₀ ^{–0,3}	1,7 ₀ ^{–0,1}	25,4	9,5	–	44,6	–	5
	–	19	25,4	–	–	37,7	18,8	46,8	–	60,3	5
	–	19	21,7	–	–	37,7	18,8	46,8	–	60,3	5
40	–	21	–	–	–	30,2	11	–	49,4	–	5
	86,6	21	–	4,98 ₀ ^{–0,3}	1,7 ₀ ^{–0,1}	30,2	11	–	49,4	–	5
	–	21	28,1	–	–	42,9	21,4	52,3	–	68,3	5
–	21	23,5	–	–	42,9	21,4	52,3	–	68,3	5	
45	–	22	–	–	–	30,2	11	–	54,5	–	5
	–	22	26,4	–	–	42,9	21,4	57,9	–	72,3	5
	–	22	26,4	–	–	42,9	21,4	57,9	–	72,3	5
50	–	22	–	–	–	30,2	11	–	59,4	–	5
	–	22	26,4	–	–	49,2	24,6	62,8	–	77,3	5
	–	22	26,4	–	–	49,2	24,6	62,8	–	77,3	5
60	–	24	–	–	–	37,1	13,5	–	72	–	5
	–	24	29	–	–	61,9	31	76,5	–	94,5	5
70	–	28	32	–	–	48,5	21,5	85,2	–	109	6





Radial insert ball bearings with grub screws in inner ring

Spherical outside surface of outer ring

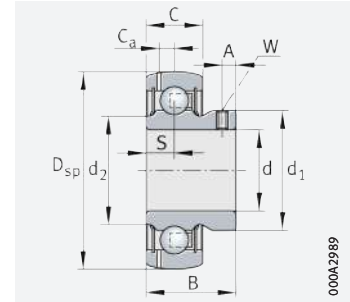

GAY.-XL-NPP-B, AY.-XL-NPP-B

d = 12 – 35 mm

Main dimensions			Basic load ratings		Fatigue limit load	Factor ¹⁾	Mass	Designation ²⁾
d	D _{sp}	B	dyn. C _r	stat. C _{0r}	C _{ur}	f ₀	m	
			N	N	N		≈ kg	
12	40	27,4	10 100	4 750	241	13,1	0,11	GYE12-XL-KRR-B
	40	22	10 100	4 750	241	13,1	0,1	AY12-XL-NPP-B
	40	22	10 100	4 750	241	13,1	0,1	GAY12-XL-NPP-B
	40	22	10 100	4 750	241	13,1	0,1	GAY12-XL-NPP-B-FA164
15	40	27,4	10 100	4 750	241	13,1	0,1	GYE15-XL-KRR-B
	40	22	10 100	4 750	241	13,1	0,09	AY15-XL-NPP-B
	40	22	10 100	4 750	241	13,1	0,09	GAY15-XL-NPP-B
	40	22	10 100	4 750	241	13,1	0,09	GAY15-XL-NPP-B-FA164
16	40	27,4	10 100	4 750	241	13,1	0,09	GYE16-XL-KRR-B
17	40	27,4	10 100	4 750	241	13,1	0,09	GYE17-XL-KRR-B
	40	22	10 100	4 750	241	13,1	0,08	AY17-XL-NPP-B
	40	22	10 100	4 750	241	13,1	0,08	GAY17-XL-NPP-B
20	47	31	13 600	6 600	335	13,1	0,14	GYE20-XL-KRR-B
	47	25	13 600	6 600	335	13,1	0,13	AY20-XL-NPP-B
	47	25	13 600	6 600	335	13,1	0,13	GAY20-XL-NPP-B
25	52	34,1	14 900	7 800	395	13,8	0,19	GYE25-XL-KRR-B
	52	27	14 900	7 800	395	13,8	0,16	AY25-XL-NPP-B
	52	27	14 900	7 800	395	13,8	0,16	GAY25-XL-NPP-B
30	62	38,1	20 700	11 300	570	13,8	0,31	GYE30-XL-KRR-B
	62	30	20 700	11 300	570	13,8	0,25	AY30-XL-NPP-B
	62	30	20 700	11 300	570	13,8	0,26	GAY30-XL-NPP-B
35	72	42,9	27 500	15 300	770	13,8	0,46	GYE35-XL-KRR-B
	72	35	27 500	15 300	770	13,8	0,41	GAY35-XL-NPP-B

medias ► <https://www.schaeffler.de/std/1DD6>

1) Factor f₀ for determining equivalent bearing load ► 1489 | 22.

2) Permissible speeds of radial insert ball bearings ► 1476.

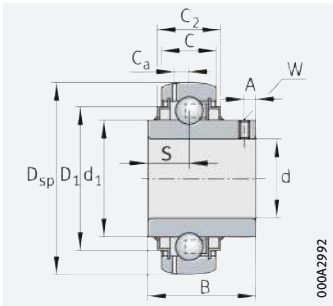

GYE...XL-KRR-B

Dimensions									Width across flats
d	C	C ₂	S	d ₁	d ₂	D ₁	C _a	A	W
12	12	16,6	11,5	23,9	–	31,6	3,4	4	2,5
	12	–	6	23,9	22,9	–	–	4	2,5
	12	–	6	23,9	22,9	–	3,4	4	2,5
	12	–	6	23,9	22,9	–	3,4	4	2,5
15	12	16,6	11,5	23,9	–	31,6	3,4	4	2,5
	12	–	6	23,9	22,9	–	–	4	2,5
	12	–	6	23,9	22,9	–	3,4	4	2,5
	12	–	6	23,9	22,9	–	3,4	4	2,5
16	12	16,6	11,5	23,9	–	31,6	3,4	4	2,5
17	12	16,6	11,5	23,9	–	31,6	3,4	4	2,5
	12	–	6	23,9	22,9	–	–	4	2,5
	12	–	6	23,9	22,9	–	3,4	4	2,5
20	14	16,6	12,7	27,6	–	37,4	4	4,5	2,5
	14	–	7	28,3	26,7	–	–	4,5	2,5
	14	–	7	28,3	26,7	–	4	4,5	2,5
25	15	16,7	14,3	33,8	–	42,5	3,9	5	2,5
	15	–	7,5	33,5	30,4	–	–	5	2,5
	15	–	7,5	33,5	30,4	–	3,9	5	2,5
30	18	20,7	15,9	40,2	–	52	4,7	5,8	3
	18	–	9	39,4	37,3	–	–	5,8	3
	18	–	9	39,4	37,3	–	4,7	5,8	3
35	19	22,5	17,5	46,8	–	60,3	5,6	6	3
	19	–	9,5	46,9	44,5	–	5,6	6	3





Radial insert ball bearings with grub screws in inner ring

Spherical outside surface of outer ring

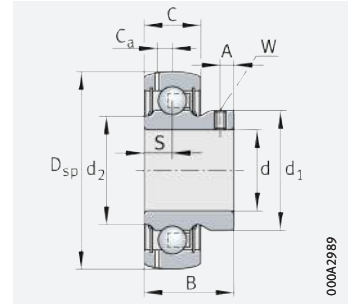

GAY.-XL-NPP-B

d = 40 – 90 mm

Main dimensions			Basic load ratings		Fatigue limit load	Factor ¹⁾	Mass	Designation ²⁾
d	D _{sp}	B	dyn. C _r	stat. C _{0r}	C _{ur}	f ₀	m	
			N	N	N		≈ kg	
40	80	49,2	34 500	19 800	1 010	14	0,62	GYE40-XL-KRR-B
	80	39,5	34 500	19 800	1 010	14	0,53	GAY40-XL-NPP-B
45	90	51,6	37 500	23 200	1 180	14,3	0,8	GYE45-210-XL-KRR-B³⁾
	85	49,2	34 500	20 400	1 030	14,3	0,71	GYE45-XL-KRR-B
	85	41,5	34 500	20 400	1 030	14,3	0,6	GAY45-XL-NPP-B
50	90	51,6	37 500	23 200	1 180	14,3	0,79	GYE50-XL-KRR-B
	90	43	37 500	23 200	1 180	14,3	0,67	GAY50-XL-NPP-B
55	100	55,6	46 000	29 000	1 480	14,3	1,08	GYE55-XL-KRR-B
60	110	65,1	56 000	36 000	1 820	14,3	1,46	GYE60-XL-KRR-B
	110	47	56 000	36 000	1 820	14,3	1,17	GAY60-XL-NPP-B
65	125	74,6	66 000	44 000	2 230	14,4	2,25	GYE65-214-XL-KRR-B⁴⁾
70	125	74,6	66 000	44 000	2 230	14,4	1,95	GYE70-XL-KRR-B
75	130	77,8	66 000	44 500	2 240	14,7	2,07	GYE75-XL-KRR-B
80	140	82,6	76 000	54 000	2 600	14,6	2,7	GYE80-XL-KRR-B
90	160	96	109 000	79 000	3 550	14,6	3,93	GYE90-XL-KRR-B⁵⁾

medias ► <https://www.schaeffler.de/std/1DD7>

- 1) Factor f₀ for determining equivalent bearing load ► 1489 | 22.
- 2) Permissible speeds of radial insert ball bearings ► 1476.
- 3) Alternative ball set 6210.
- 4) Alternative ball set 6214.
- 5) Lubrication groove in outer ring.

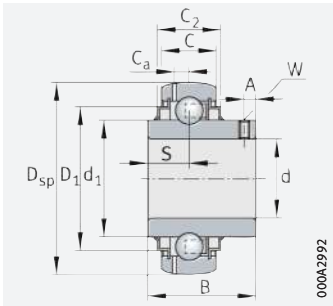

GYE...XL-KRR-B

Dimensions									Width across flats W
d	C	C ₂	S	d ₁	d ₂	D ₁	C _a	A	W
40	21	23,5	19	52,3	–	68,3	6,4	8	4
	21	–	10,5	52,4	49,3	–	6,4	8	4
45	22	26,4	19	62,9	–	77,3	6,9	8,5	4
	22	26,4	19	57	–	72,3	6,4	8	4
	22	–	11	57	54,3	–	6,4	8	4
50	22	26,4	19	62,8	–	77,3	6,9	8,5	4
	22	–	11	62	59,3	–	6,9	9	4
55	25	29	22,2	69,8	–	85,9	7	9	4
60	24	29	25,4	76,5	–	94,5	7,2	10,1	5
	24	–	13	76	73,6	–	7,2	10	5
65	28	32	30,2	85,2	–	109	8,9	12,1	5
70	28	32	30,2	85,2	–	109	8,9	12	5
75	28	30,5	33,3	90	–	113	8,5	12,7	5
80	30	38	33,3	97	–	120	8,8	12	5
90	32	35	39,7	109,4	–	138	10	12	6





Inch size radial insert ball bearings

Spherical outside surface of outer ring

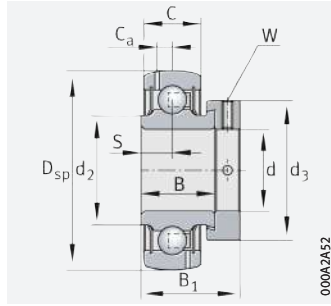

GRA..-NPP-B-AS2/V

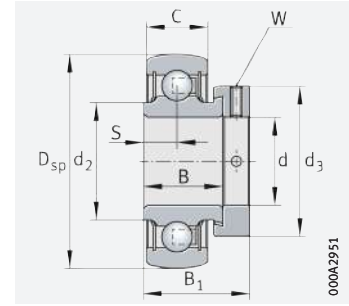

RA..-NPP-B

d = 1/2 – 1 inch

Main dimensions				Basic load ratings		Fatigue limit load	Factor ¹⁾	Mass	Designation ²⁾		
d		D _{sp}	B	B ₁	d ₃	dyn. C _r	stat. C _{0r}	C _{ur}	f ₀	m	▶ 1485 1.12 ▶ 1486 1.13
inch	mm					N	N				
1/2	12,7	40	27,3	–	–	10 100	4 750	241	13,1	0,11	GY1008-KRR-B-AS2/V
5/8	15,875	40	19	28,6	28	10 100	4 750	241	13,1	0,11	GRA010-NPP-B-AS2/V
		40	22	–	–	10 100	4 750	241	13,1	0,09	GAY010-NPP-B-AS2/V
		40	27,3	–	–	10 100	4 750	241	13,1	0,1	GY1010-KRR-B-AS2/V
		40	27,7	37,3	28	10 100	4 750	241	13,1	0,13	G1010-KRR-B-AS2/V
3/4	19,05	47	21,4	31	33	13 600	6 600	335	13,1	0,16	GRA012-NPP-B-AS2/V
		47	25	–	–	13 600	6 600	335	13,1	0,13	GAY012-NPP-B-AS2/V
		47	31	–	–	13 200	6 100	310	13,1	0,15	GY1012-KRR-B-AS2/V
		47	34,1	43,7	33	13 600	6 600	335	13,1	0,21	G1012-KRR-B-AS2/V
7/8	22,225	52	21,4	31	37,5	14 900	7 800	395	13,8	0,21	GRA014-NPP-B-AS2/V
		52	34,1	–	–	14 900	7 800	395	13,8	0,21	GY1014-KRR-B-AS2/V
		52	34,9	44,5	37,5	14 900	7 800	395	13,8	0,27	G1014-KRR-B-AS2/V
15/16	23,8125	52	34,1	–	–	14 900	7 800	395	13,8	0,2	GY1015-KRR-B-AS2/V
		52	34,9	44,5	37,5	14 900	7 800	395	13,8	0,25	G1015-KRR-B-AS2/V
1	25,4	52	21,4	31	37,5	14 900	7 800	395	13,8	0,19	RA100-NPP-B
		52	21,4	31	37,5	14 900	7 800	395	13,8	0,18	GRA100-NPP-B-AS2/V
		52	27	–	–	14 900	7 800	395	13,8	0,15	GAY100-NPP-B-AS2/V
		52	34,1	–	–	14 900	7 800	395	13,8	0,18	GY1100-KRR-B-AS2/V
		52	34,9	44,5	37,5	14 900	7 800	395	13,8	0,23	G1100-KRR-B-AS2/V

medias ▶ <https://www.schaeffler.de/std/1DD8>

1) Factor f₀ for determining equivalent bearing load ▶ 1489 | 22.

2) Permissible speeds of radial insert ball bearings ▶ 1476.

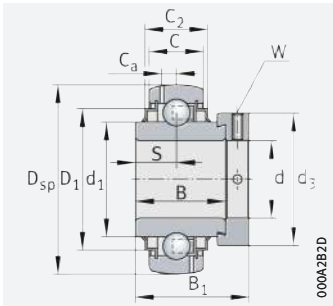

G..-KRR-B-AS2/V

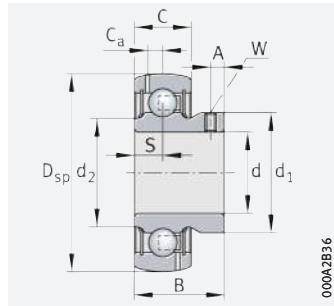

GAY..-NPP-B(-AS2/V)

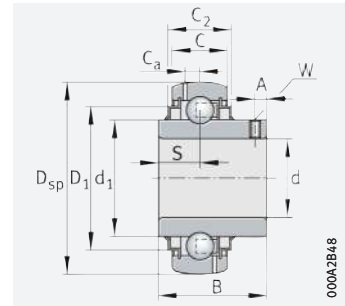

GY..-KRR-B-AS2/V

Dimensions										Width across flats W
d		C	C ₂	S	d ₁	d ₂	D ₁	C _a	A	inch
inch	mm									
1/2	12,7	12	–	11,5	23,9	–	–	3,4	4	3/32
5/8	15,875	12	–	6,5	–	23	–	3,4	–	1/8
		12	–	6	23	23	–	3,4	4	3/32
		12	–	11,5	23,9	–	–	3,4	4	3/32
		12	–	13,9	23,9	–	–	3,4	–	1/8
3/4	19,05	14	–	7,5	–	26,9	–	3,9	–	1/8
		14	–	7	27,8	26,9	–	3,9	4,5	3/32
		14	16,2	12,7	27,6	–	37,4	3,9	4,5	3/32
		14	16,2	17,1	27,6	–	37,4	3,9	–	1/8
7/8	22,225	15	–	7,5	–	30,3	–	3,9	–	1/8
		15	16,5	14,3	33,8	–	42,5	3,9	4,9	3/32
		15	16,5	17,5	33,8	–	42,5	3,9	–	1/8
15/16	23,8125	15	16,5	14,3	33,8	–	42,5	3,9	4,9	3/32
		15	16,5	17,5	33,8	–	42,5	3,9	–	1/8
1	25,4	15	–	7,5	–	30,5	–	–	–	1/8
		15	–	7,5	–	30,3	–	3,9	–	1/8
		15	–	7,5	33,6	30,4	–	3,9	5	3/32
		15	16,5	14,3	33,8	–	42,5	3,9	5	3/32
		15	16,5	17,5	33,8	–	42,5	3,9	–	1/8





Inch size radial insert ball bearings

Spherical outside surface of outer ring

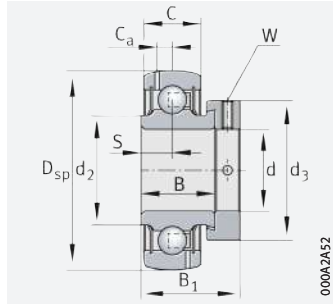

GRA..-NPP-B-AS2/V

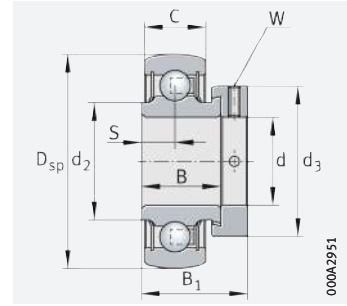

RA..-NPP-B

d = 1¹/₈ – 1⁷/₁₆ inch

Main dimensions					Basic load ratings		Fatigue limit load	Factor ¹⁾	Mass	Designation ²⁾	
d		D _{sp}	B	B ₁	d ₃	dyn. C _r	stat. C _{0r}	C _{ur}	f ₀	m ≈ kg	▶ 1485 1.12 ▶ 1486 1.13
inch	mm					N	N				
1 ¹ / ₈	28,575	62	23,8	35,8	44	20 700	11 300	570	13,8	0,32	GRA102-NPP-B-AS2/V
		62	36,5	48,5	44	20 700	11 300	570	13,8	0,4	G1102-KRR-B-AS2/V
		62	38,1	–	–	20 700	11 300	570	13,8	0,32	GY1102-KRR-B-AS2/V
1 ³ / ₁₆	30,1625	62	23,8	35,8	44	20 700	11 300	570	13,8	0,3	GRA103-NPP-B-AS2/V
		62	36,5	48,35	44	20 700	11 300	570	13,8	0,37	G1103-KRR-B-AS2/V
		62	38,1	–	–	20 700	11 300	570	13,8	0,3	GY1103-KRR-B-AS2/V
1 ¹ / ₄	31,75	62	23,8	35,8	44	20 700	11 300	570	13,8	0,31	RA104-206-NPP-B
		62	23,8	35,8	44	20 700	11 300	570	13,8	0,28	GRA104-206-NPP-B-AS2/V
		62	36,5	48,5	44	20 700	11 300	570	13,8	0,34	G1104-206-KRR-B-AS2/V
		62	38,1	–	–	20 700	11 300	570	13,8	0,27	GY1104-206-KRR-B-AS2/V
		72	25,4	39	51	27 500	15 300	770	13,8	0,48	RA104-NPP-B
		72	25,4	39	51	27 500	15 300	770	13,8	0,5	GRA104-NPP-B-AS2/V
		72	35	–	–	27 500	15 300	770	13,8	0,44	GAY104-NPP-B-AS2/V ³⁾
		72	37,7	51,3	51	27 500	15 300	770	13,8	0,65	G1104-KRR-B-AS2/V
		72	42,9	–	–	27 500	15 300	770	13,8	0,5	GY1104-KRR-B-AS2/V
1 ³ / ₈	34,925	72	25,4	39	51	27 500	15 300	770	13,8	0,45	GRA106-NPP-B-AS2/V
		72	37,7	51,3	51	27 500	15 300	770	13,8	0,54	G1106-KRR-B-AS2/V
		72	42,9	–	–	27 500	15 300	770	13,8	0,45	GY1106-KRR-B-AS2/V
1 ⁷ / ₁₆	36,5125	72	25,4	39	51	27 500	15 300	770	13,8	0,43	GRA107-NPP-B-AS2/V
		72	35	–	–	27 500	15 300	770	13,8	0,37	GAY107-NPP-B-AS2/V
		72	37,7	51,3	51	27 500	15 300	770	13,8	0,5	G1107-KRR-B-AS2/V
		72	42,9	–	–	27 500	15 300	770	13,8	0,42	GY1107-KRR-B-AS2/V

medias ▶ <https://www.schaeffler.de/std/1DD9>

- Factor f₀ for determining equivalent bearing load ▶ 1489 | 22.
- Permissible speeds of radial insert ball bearings ▶ 1476.
- Available by agreement.

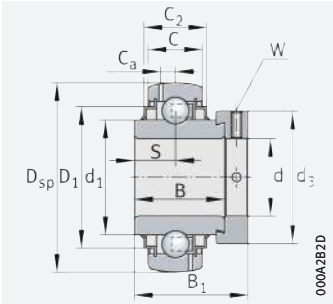

G..-KRR-B-AS2/V

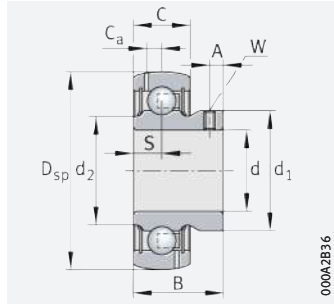

GAY..-NPP-B-AS2/V

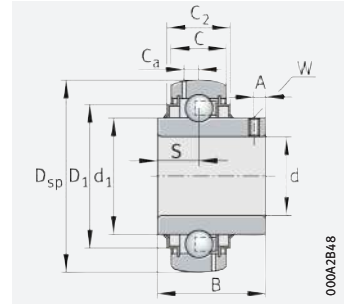

GY..-KRR-B-AS2/V

Dimensions

d		C	C ₂	S	d ₁	d ₂	D ₁	C _a	A	Width across flats W
inch	mm									
1 1/8	28,575	18	–	9	–	37,3	–	5	–	5/32
		18	20,7	18,3	40,2	–	52	5	–	5/32
		18	20	15,9	40,2	–	51,8	5	5,6	1/8
1 3/16	30,1625	18	–	9	–	37,3	–	4,9	–	5/32
		18	20,7	18,3	40,2	–	52	5	–	5/32
		18	20	15,9	40,2	–	51,8	5	5,6	1/8
1 1/4	31,75	18	–	9	–	37,4	–	–	–	5/32
		18	–	9	–	37,3	–	5	–	5/32
		18	20,7	18,3	40,2	–	52	5	–	5/32
		18	20	15,9	40,2	–	51,8	5	5,6	1/8
		19	–	9,5	–	44,6	–	–	–	3/16
		19	–	9,5	–	44,5	–	5,7	–	3/16
		19	–	9,5	47,1	44,5	–	5,7	8	1/8
		19	22,5	18,8	46,8	–	60,3	5,7	–	5/32
		19	20,7	17,5	46,8	–	60,2	5,7	5,9	1/8
1 3/8	34,925	19	–	9,5	–	44,5	–	5,7	–	3/16
		19	22,5	18,8	46,8	–	60,3	5,7	–	3/16
		19	20,7	17,5	46,8	–	60	5,7	7,9	1/8
1 7/16	36,5125	19	–	9,5	–	44,5	–	5,7	–	3/16
		19	–	9,5	47,1	44,5	–	5,7	8	1/8
		19	20,7	18,8	46,8	–	60,3	5,7	–	3/16
		19	20,7	17,5	46,8	–	60	5,7	6	1/8





Inch size radial insert ball bearings

Spherical outside surface of outer ring

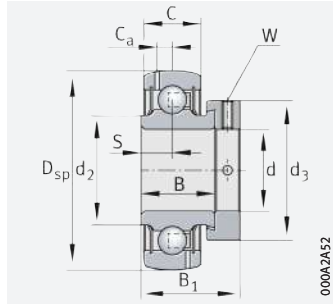

GRA..-NPP-B-AS2/V

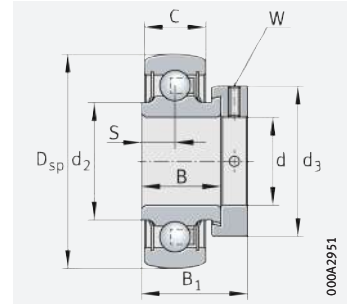

RA..-NPP-B

d = 1^{1/2} – 2^{15/16} inch

Main dimensions					Basic load ratings		Fatigue limit load	Factor ¹⁾	Mass	Designation ²⁾	
d		D _{sp}	B	B ₁	d ₃	dyn. C _r	stat. C _{0r}	C _{ur}	f ₀	m	➤ 1485 1.12 ➤ 1486 1.13
inch	mm					N	N				
1 ^{1/2}	38,1	80	30,2	43,8	58	34 500	19 800	1 010	14	0,62	RA108-NPP-B
		80	30,2	43,8	58	34 500	19 800	1 010	14	0,64	GRA108-NPP-B-AS2/V
		80	42,9	56,5	58	34 500	19 800	1 010	14	0,76	G1108-KRR-B-AS2/V
1 ^{5/8}	41,275	85	42,9	56,5	63	34 500	20 400	1 030	14,3	0,9	G1110-KRR-B-AS2/V
1 ^{11/16}	42,8625	85	42,9	56,5	63	34 500	20 400	1 030	14,3	0,85	G1111-KRR-B-AS2/V
1 ^{3/4}	44,45	85	42,9	56,5	63	34 500	20 400	1 030	14,3	0,81	G1112-KRR-B-AS2/V
		85	49,2	–	–	34 500	20 400	1 030	14,3	0,68	GY1112-KRR-B-AS2/V
1 ^{15/16}	49,2125	90	30,2	43,8	69	37 500	23 200	1 180	14,3	0,75	GRA115-NPP-B-AS2/V³⁾
		90	49,2	62,75	69	37 500	23 200	1 180	14,3	1,01	G1115-KRR-B-AS2/V
		90	51,6	–	–	37 500	23 200	1 180	14,3	0,82	GY1115-KRR-B-AS2/V
2	50,8	100	55,5	71,4	76	46 000	29 000	1 480	14,3	1,51	G1200-KRR-B-AS2/V
		100	55,6	–	–	46 000	29 000	1 480	14,3	1,18	GY1200-KRR-B-AS2/V
2 ^{3/16}	55,5625	100	55,5	71,4	76	46 000	29 000	1 480	14,3	1,28	G1203-KRR-B-AS2/V
		100	55,5	–	–	46 000	29 000	1 480	14,3	1,01	GY1203-KRR-B-AS2/V
2 ^{7/16}	61,912	110	61,9	77,9	84	56 000	36 000	1 820	14,3	1,59	G1207-KRR-B-AS2/V
2 ^{15/16}	74,6125	130	49,5	67	100,5	66 000	44 500	2 240	14,7	2,09	G1215-KRR-B-AS2/V
		130	77,8	–	–	66 000	44 500	2 240	14,7	2,01	GY1215-KRR-B-AS2/V

medias ➤ <https://www.schaeffler.de/std/1DDA>

- 1) Factor f₀ for determining equivalent bearing load ➤ 1489 | 22.
- 2) Permissible speeds of radial insert ball bearings ➤ 1476.
- 3) Available by agreement.

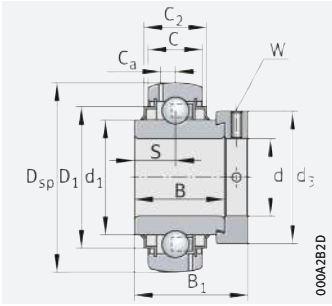

G..-KRR-B-AS2/V

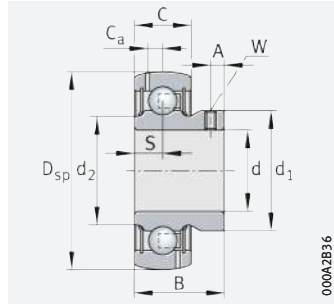

GAY..-NPP-B-AS2/V

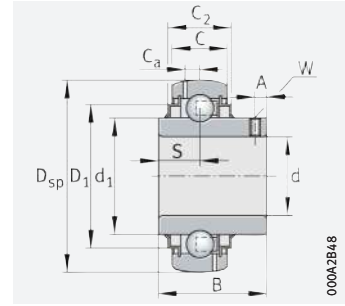

GY..-KRR-B-AS2/V

Dimensions

d		C	C ₂	S	d ₁	d ₂	D ₁	C _a	A	Width across flats W
inch	mm									
1¹/₂	38,1	21	–	11	–	49,4	–	–	–	3/16
		21	–	11	–	49,3	–	6,5	–	3/16
		21	22,5	21,4	52,3	–	68,3	6,5	–	3/16
1⁵/₈	41,275	22	25,7	21,4	57,9	–	72,3	6,4	–	3/16
1¹¹/₁₆	42,8625	22	25,7	21,4	57,9	–	72,3	6,4	–	3/16
1³/₄	44,45	22	25,7	21,4	57,9	–	72,3	6,4	–	3/16
		22	25,7	19	57,9	–	71,7	6,4	8	5/32
1¹⁵/₁₆	49,2125	22	–	11	–	59,3	–	6,8	–	3/16
		22	26,1	24,6	62,8	–	77,3	6,8	–	3/16
		22	26	19	62,8	–	76,7	6,8	10	5/32
2	50,8	25	28,4	27,8	69,8	–	85,9	7,1	–	3/16
		25	28,4	22,2	69,8	–	85,3	7,1	9,1	5/32
2³/₁₆	55,5625	25	28,4	27,8	69,8	–	85,3	7,08	–	3/16
		25	28,4	22,2	69,8	–	85,3	7,1	10	5/32
2⁷/₁₆	61,912	24	29,3	31	76,5	–	95,3	7,8	–	3/16
2¹⁵/₁₆	74,6125	28	30,5	21,5	99	–	112,9	8,56	–	1/4
		28	31,5	33,4	90	–	113	8,5	12,6	3/16





Inch size radial insert ball bearings

Cylindrical outside surface of outer ring

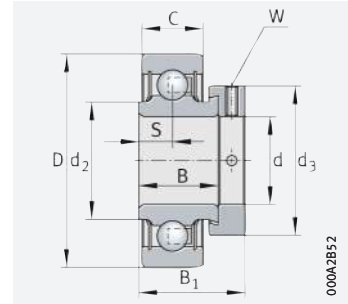

RA...NPP, RAL...NPP

d = 3/4 – 1 1/2 inch

Main dimensions					Basic load ratings		Fatigue limit load	Factor ¹⁾	Mass	Designation ²⁾
d		D	B ₁	d ₃ max.	dyn. C _r N	stat. C _{0r} N	C _{ur} N	f ₀	m ≈ kg	► 1485 1.12 ► 1486 1.13
inch	mm									
3/4	19,05	42	24,6	30	10 000	5 000	255	13,9	0,09	RAL012-NPP
7/8	22,225	52	31	37,5	14 900	7 800	395	13,8	0,19	RA014-NPP
1	25,4	52	31	37,5	14 900	7 800	395	13,8	0,19	RA100-NPP
1 1/8	28,575	62	35,8	44	20 700	11 300	570	13,8	0,31	RA102-NPP
1 3/16	30,1625	62	35,8	44B	20 700	11 300	570	13,8	0,31	RA103-NPP
1 1/4	31,75	62	35,8	44	20 700	11 300	570	13,8	0,31	RA104-206-NPP
		72	39	51	27 500	15 300	770	13,8	0,48	RA104-NPP
1 7/16	36,5125	72	39	51	27 500	15 300	770	13,8	0,48	RA107-NPP
1 1/2	38,1	80	43,8	58	34 500	19 800	1 010	14	0,62	RA108-NPP

medias ► <https://www.schaeffler.de/std/1DDB>

- 1) Factor f₀ for determining equivalent bearing load ► 1489 | 22.
- 2) Permissible speeds of radial insert ball bearings ► 1476.



Dimensions						Width across flats
d		C	B	S	d ₂	W
inch	mm					inch
3/4	19,05	12	16,7	6	25,4	1/8
7/8	22,225	15	21,4	7,5	30,5	1/8
1	25,4	15	21,4	7,5	30,5	1/8
1 1/8	28,575	18	23,8	9	37,4	5/32
1 3/16	30,1625	18	23,8	9	37,4	5/32
1 1/4	31,75	18	23,8	9	37,4	5/32
		19	25,4	9,5	44,6	3/16
1 7/16	36,5125	19	25,4	9,5	44,6	3/16
1 1/2	38,1	21	30,2	11	49,4	3/16





Radial insert ball bearings with adapter sleeve

Spherical outside surface of outer ring

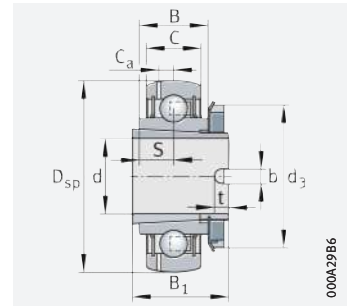

GSH..-XL-2RSR-B

000A29B6

d = 20 – 50 mm

Main dimensions				Basic load ratings		Fatigue limit load	Limiting speed ¹⁾	Factor ²⁾	Mass	Designation
d	D _{sp}	B ₁	d ₃	dyn. C _r	stat. C _{0r}	C _{ur}	n _G grease	f ₀	m	
H8			max.	N	N	N	min ⁻¹		≈ kg	
20	47	28	32	13 400	7 000	355	8 700	13,1	0,14	GSH20-XL-2RSR-B
25	52	28	38	14 400	8 100	410	7 500	13,8	0,17	GSH25-XL-2RSR-B
30	62	32	45	20 100	11 600	590	6 200	13,8	0,27	GSH30-XL-2RSR-B
35	72	34	52	26 500	15 700	800	5 500	13,8	0,43	GSH35-XL-2RSR-B
40	80	38	58	31 000	19 700	1 000	4 850	14	0,54	GSH40-XL-2RSR-B
45	85	46	62	31 000	20 100	1 020	4 500	14,3	0,69	GSH45-XL-2RSR-B
50	90	40	70	35 000	23 100	1 170	4 150	14,3	0,64	GSH50-XL-2RSR-B

medias ► <https://www.schaeffler.de/std/1DDC>

- 1) Preferably for shafts of tolerance classes h6 © to h11 ©.
- 2) Factor f₀ for determining equivalent bearing load ► 1489 | 22.



Dimensions

d	C	B	S	C _a	b	t
H8						
20	14	15	7,5	4	5	5
25	15	15	7,5	3,9	5	5
30	18	18	9	4,7	5	5
35	19	19	9,5	5,8	5	5
40	21	22	11	6,4	5	5
45	22	36	18	6,4	5	5
50	22	22	11	6,5	5	5





Radial insert ball bearings with drive slot

Non-locating bearings
Spherical outside surface of outer ring

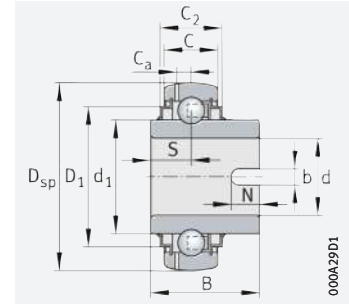

GLE..-XL-KRR-B

d = 20 – 70 mm

Main dimensions			Basic load ratings		Fatigue limit load	Factor ¹⁾	Mass	Designation ²⁾
d	D _{sp}	B	dyn. C _r	stat. C _{0r}	C _{ur}	f ₀	m	
			N	N	N		≈ kg	
20	47	34,1	13 600	6 600	335	13,1	0,15	GLE20-XL-KRR-B
25	52	34,9	14 900	7 800	395	13,8	0,19	GLE25-XL-KRR-B
30	62	36,5	20 700	11 300	570	13,8	0,3	GLE30-XL-KRR-B
35	72	37,7	27 500	15 300	770	13,8	0,43	GLE35-XL-KRR-B
40	80	42,9	34 500	19 800	1 010	14	0,57	GLE40-XL-KRR-B
45	85	42,9	34 500	20 400	1 030	14,3	0,66	GLE45-XL-KRR-B
50	90	49,2	37 500	23 200	1 180	14,3	0,76	GLE50-XL-KRR-B
60	110	61,9	56 000	36 000	1 820	14,3	1,46	GLE60-XL-KRR-B
70	125	68,2	66 000	44 000	2 230	14,4	1,9	GLE70-XL-KRR-B

medias ► <https://www.schaeffler.de/std/1DDD>

1) Factor f₀ for determining equivalent bearing load ► 1489 | 22.

2) Permissible speeds of radial insert ball bearings ► 1476.



Dimensions

d	C	C ₂	S	d ₁	D ₁	C _a	N	b
								H11
20	14	16,6	15,6	27,6	37,4	4	7	7
25	15	16,7	14,7	33,8	42,5	3,9	8	7
30	18	20,7	14,5	40,2	52	4,7	8	7
35	19	22,5	15,7	46,8	60,3	5,6	8	7
40	21	23,5	15,9	52,3	68,3	6,4	9	7
45	22	26,4	17,4	57,9	72,3	6,4	9	7
50	22	26,4	19	62,8	77,3	6,9	10	7
60	24	29	24,6	76,5	95,9	7,2	12	9
70	28	32	27	85,2	109	8,9	12	9





Self-aligning deep groove ball bearings

Spherical outside surface of outer ring

Bore for fit

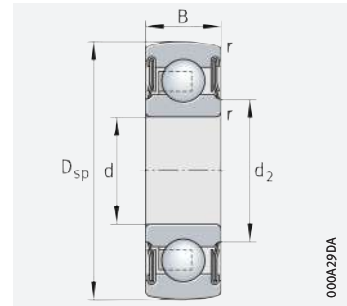

2..-XL-NPP-B

000A29DA

d = 12 – 50 mm

Main dimensions			Basic load ratings		Fatigue limit load C_{ur} N	Limiting speed n_G grease min^{-1}	Factor ¹⁾ f_0	Mass m \approx kg	Designation ► 1485 1.12 ► 1486 1.13 X-life ► 1453	Dimensions	
d	D_{sp}	B	dyn. C_r N	stat. C_{0r} N						d_2	r_{min}
12	32	10	7 200	3 050	154	14 600	12,3	0,04	201-XL-NPP-B²⁾	17,1	0,6
17	40	12	10 100	4 750	241	11 100	13,1	0,06	203-XL-NPP-B³⁾	22,5	0,6
20	47	14	13 600	6 600	335	9 300	13,1	0,11	204-XL-NPP-B³⁾	26,5	1
25	52	15	14 900	7 800	395	8 000	13,8	0,13	205-XL-NPP-B³⁾	30,3	1
30	62	16	20 700	11 300	570	6 700	13,8	0,2	206-XL-NPP-B²⁾	37,4	1
35	72	17	27 500	15 300	770	5 700	13,8	0,29	207-XL-NPP-B²⁾	42,4	1
40	80	18	34 500	19 800	1 010	5 000	14	0,37	208-XL-NPP-B²⁾	48,4	1,1
45	85	19	34 500	20 400	1 030	4 650	14,3	0,41	209-XL-NPP-B²⁾	53,2	1,1
50	90	20	37 500	23 200	1 180	4 300	14,3	0,46	210-XL-NPP-B³⁾	58,2	1,1

medias ► <https://www.schaeffler.de/std/1DDE>

1) Factor f_0 for determining equivalent bearing load ► 1489 | 22.

2) One-piece seal with vulcanised seal lip.

3) Three-piece P seal.





Deep groove ball bearings with extended inner ring

Cylindrical outside surface of outer ring
Bore for fit

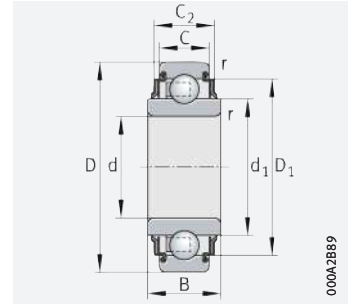

2..-XL-KRR, 2..-XL-KRR-AH..

000A2B89

d = 13 – 60 mm

Main dimensions			Basic load ratings		Fatigue limit load	Limiting speed	Factor ¹⁾	Mass	Designation ²⁾	
d	D	B	dyn. C _r	stat. C _{0r}	C _{ur}	n _G grease	f ₀	m		
			N	N	N	min ⁻¹		≈ kg		
13	+0,08 -0,05	40	18,3	10 100	4 750	241	11 100	13,1	0,09	203-XL-KRR-AH05³⁾
15		35	14,4	8 100	3 700	187	12 700	13,1	0,05	202-XL-KRR
16,2	+0,1 0	40	18,3	10 100	4 750	241	11 100	13,1	0,07	203-XL-KRR-AH02
17		40	18,3	10 100	4 750	241	11 100	13,1	0,07	203-XL-KRR
20		47	17,7	13 600	6 600	335	9 300	13,1	0,12	204-XL-KRR
25		52	21	14 900	7 800	395	8 000	13,8	0,16	205-XL-KRR
30		62	24	20 700	11 300	570	6 700	13,8	0,24	206-XL-KRR
35		72	25	27 500	15 300	770	5 700	13,8	0,35	207-XL-KRR-AH03⁴⁾
38,892		80	27,5	34 500	19 800	1 010	5 000	14	0,48	208-XL-KRR-AH04⁴⁾
40		80	27	34 500	19 800	1 010	5 000	14	0,44	208-XL-KRR
45		85	30	34 500	20 400	1 030	4 650	14,3	0,53	209-XL-KRR
50		90	30	37 500	23 200	1 180	4 300	14,3	0,58	210-XL-KRR
55		100	36	46 000	29 000	1 480	3 900	14,3	0,85	211-XL-KRR
60		110	36	56 000	36 000	1 820	3 550	14,3	1,1	212-XL-KRR

medias ► <https://www.schaeffler.de/std/1DDF>

- Factor f₀ for determining equivalent bearing load ► 1489 | 22.
- Internal clearance Group N.
- Greased with L114 (GA47).
- With steel cage.



Dimensions

d		C	C ₂	d ₁	D ₁	r _{min}
13	+0,08 -0,05	12	12	24,2	40	0,6
15		11	11	21,5	28,8	0,6
16,2	+0,1 0	12	12	24,2	32,6	0,6
17		12	12	24,2	32,9	0,6
20		14	14	28,7	38,7	1
25		15	16,7	33,8	42,6	1
30		16	19,6	40,2	52	1
35		17	19,7	46,8	60,3	2
38,892		21	21,2	52,3	68,2	1
40		18	20,5	52,3	68,2	1,1
45		19	26,4	57,9	72,3	1,1
50		20	24	62,8	77,6	1,1
55		21	27,5	69,8	85,9	1,5
60		22	30	76,5	94,7	1,5





Self-aligning deep groove ball bearings

Spherical outside surface of outer ring
Square bore

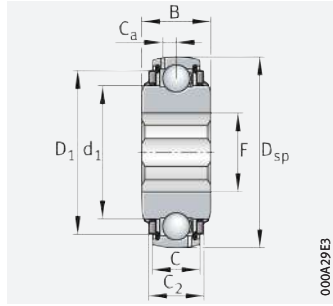

GVK(E)..-KTT-B(-AS2/V)(-AH)

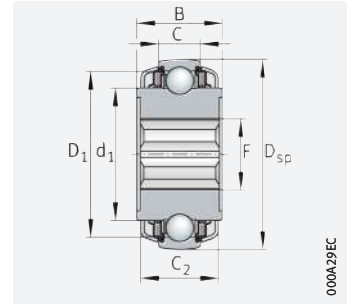

VKE..-KTT-B-2C

d = 16,3 – 39,6875 mm

Main dimensions			Basic load ratings		Fatigue limit load C_{ur} N	Factor ¹⁾ f_0	Mass m ≈ kg	Designation		
d		D_{sp}	B	dyn. C_r N					stat. C_{0r} N	
mm	inch									
16,3	+0,2 0	–	52	28	14 900	7 800	395	13,8	0,22	GVKE16-205-KRR-B-AS2/V-AH01
	+0,2 0		52	28	14 900	7 800	395	13,8	0,24	GVKE16-205-KRR-B-2C-AS2/V-AH01
25,4	+0,9 +0,6	1	80	36,5	34 500	19 800	1 010	14	0,67	VK100-208-KTT-B-AH10
	+0,9 +0,6		80	36,5	34 500	19 800	1 010	14	0,74	GVK100-208-KTT-B-AS2/V
28	+0,9 +0,6	–	85	42,9	34 500	20 400	1 030	14,3	0,89	VKE28-209-KTT-B-GA47/70
28,575	+0,9 +0,6	1 ^{1/8}	80	36,5	34 500	19 800	1 010	14	0,62	GVK102-208-KTT-B-AH10
30	+0,13 0	–	110	49,2	56 000	36 000	1 820	14,3	2,02	VKE30-212-KTT-B-2C
	+0,9 +0,6		100	36	46 000	29 000	1 480	14,3	1,23	GVKE30-211-KTT-B-AS2/V
31,75	+0,9 +0,6	1 ^{1/4}	85	36,5	34 500	20 400	1 030	14,3	0,72	GVK104-209-KTT-B
38	+0,9 +0,6	–	100	55,2	46 000	29 000	1 480	14,3	1,42	VKE38-211-KTT-B-GA47/70-AH01
38,1	+0,9 +0,6	1 ^{1/2}	100	36	46 000	29 000	1 480	14,3	1,08	GVK108-211-KTT-B-AS2/V
39,6875	+0,3 0	1 ^{9/16}	100	36	46 000	29 000	1 480	14,3	1,07	GVK109-211-KTT-B

medias ► <https://www.schaeffler.de/std/1DE0>

- Factor f_0 for determining equivalent bearing load ► 1489 | 22.
- Dimension for flinger shield.

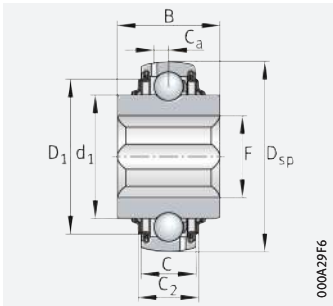

GVKE...-KRR-B-AS2/V-AH

000A29F6

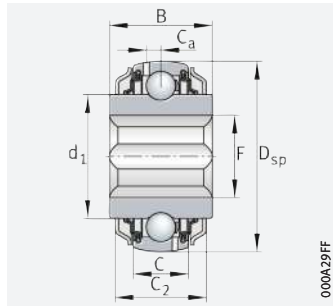

GVKE...-KRR-B-2C-AS2/V-AH

000A29FF

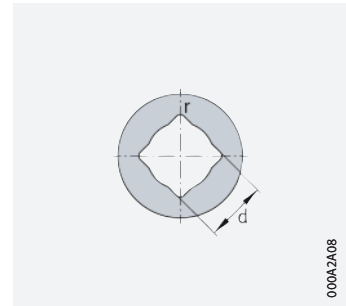

Design of bore

000A2A08

Width across flats of shaft d			Dimensions							
			C	C ₂	d ₁	F	D ₁	C _a	r	
mm	inch									
16,3	+0,2 0	–	15	16,5	33,8	22,4	42,5	3,9	0,7	
	+0,2 0		15	24,8 ²⁾	33,8	22,4	–	3,9	0,7	
25,4	+0,9 +0,6	1	18	25,2	52,3	33,8	68,4	–	2,5	
	+0,9 +0,6		21	28,1	52,3	35,4	68,3	6,4	2,5	
28	+0,9 +0,6	–	22	25,4	57,9	37,5	71,7	–	2,5	
28,575	+0,9 +0,6	1 ¹ / ₈	18	25	52,3	38,3	67,8	5,8	2,5	
30	+0,13 0	–	24	45,4 ²⁾	74,8	41,2	–	–	2,5	
	+0,9 +0,6		25	27,4	69,7	40,3	85,3	7,1	2,5	
31,75	+0,9 +0,6	1 ¹ / ₄	22	26,3	57,9	36,4	72,2	6,4	2,5	
38	+0,9 +0,6	–	25	27,4	69,7	51,8	85,3	–	2,5	
38,1	+0,9 +0,6	1 ¹ / ₂	25	27,4	69,7	43,9	85,3	7,1	2,5	
39,6875	+0,3 0	1 ⁹ / ₁₆	25	28,9	69,8	55,1	85,8	7	2,5	

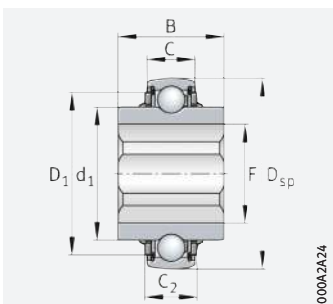

VK...-KTT-B(-AH),
VKE...-KTT-B-G47/70(-AH)

000A2A24



Self-aligning deep groove ball bearings

Spherical outside surface of outer ring
Hexagonal bore

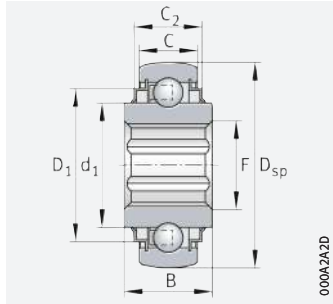

SK...-KRR-B(-L402/70)(-AH),
SKE...-KRR-B

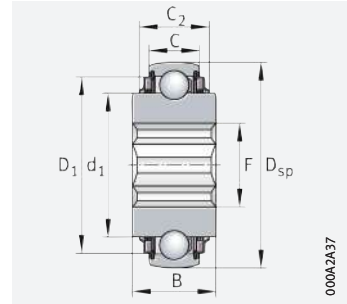

SK...-KTT-B(-L402/70)(-AH)

d = 16,1 – 38,1 mm

Main dimensions				Basic load ratings		Fatigue limit load	Factor ¹⁾	Mass	Designation
d		D _{sp}	B	dyn. C _r	stat. C _{0r}	C _{ur}	f ₀	m	
mm	inch			N	N	N		≈ kg	
16,1	+0,15 +0,05	–	47	13 600	6 600	335	13,1	0,12	SK1010-204-KRR-B
17	+0,15 +0,05	–	47	13 600	6 600	335	13,1	0,12	SKE17-204-KRR-B
22,225	+0,15 +0,05 +0,15 +0,05	7/8	52	14 900	7 800	395	13,8	0,2	SK014-205-KRR-B
			52	14 900	7 800	395	13,8	0,18	SK014-205-KTT-B-L402/70
25,4	+0,15 +0,03	1	62	20 700	11 300	570	13,8	0,32	SK100-206-KRR-B-AH11
28,575	+0,13 0 +0,175 +0,03	1 1/8	72	27 500	15 300	770	13,8	0,38	SK102-207-KRR-B-L402/70-AH11
			72	27 500	15 300	770	13,8	0,45	SK102-207-KRR-B-AH10
31,75	+0,15 +0,05 +0,15 +0,05 +0,15 +0,05 +0,15 +0,05 +0,15 +0,05	1 1/4	72	27 500	15 300	770	13,8	0,35	SK104-207-KRR-B-L402/70-AH12
			80	34 500	19 800	1 010	14	0,65	SK104-208-KTT-B-AH10
			80	34 500	19 800	1 010	14	0,6	SK104-208-KTT-B-L402/70-AH10
			72	27 500	15 300	770	13,8	0,45	SK104-207-KTT-B-L402/70
			72	27 500	15 300	770	13,8	0,48	SK104-207-KTT-B
			90	37 500	23 200	1 180	14,3	0,98	SK104-210-KTT-B-L402/70
34,925	+0,15 0	1 3/8	80	34 500	19 800	1 010	14	0,59	SK106-208-KRR-B-L402/70
38,1	+0,12 0 +0,12 0 +0,1 0	1 1/2	85	34 500	20 400	1 030	14,3	0,59	SK108-209-KRR-B-L402/70-AH11
			90	37 500	23 200	1 180	14,3	0,78	SK108-210-KRR-B
			90	37 500	23 200	1 180	14,3	0,75	SK108-210-KRR-B-AH01

medias ► <https://www.schaeffler.de/std/1DE1>

¹⁾ Factor f₀ for determining equivalent bearing load ► 1489 | 22.

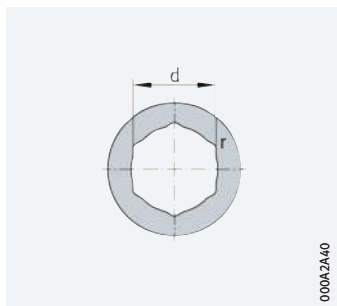

000A2A40

Design of bore

Width across flats of shaft d			Dimensions					
			C	C ₂	d ₁	F	D ₁	r
mm		inch						
16,1	+0,15 +0,05	–	14	–	27,6	19,7	–	0,13
17	+0,15 +0,05	–	14	–	28,7	20,2	–	0,13
22,225	+0,15 +0,05	7/8	15	16,7	33,8	26,2	42,6	0,13
	+0,15 +0,05		15	19	33,8	26,6	42,5	0,12
25,4	+0,15 +0,03	1	16	18,7	40,2	30,5	52	0,13
28,575	+0,13 0	1 1/8	17	18,7	46,8	34,2	60	0,25
	+0,175 +0,03		17	20,5	46,8	38	60,3	0,25
31,75	+0,15 +0,05	1 1/4	17	18,7	46,8	38	60	0,12
	+0,15 +0,05		18	25	52,3	38	68,4	0,12
	+0,15 +0,05		18	25	52,3	38	68,4	0,12
	+0,15 +0,05		19	22,7	46,8	37,2	60	0,13
	+0,15 +0,05		19	23,7	46,8	38	60	0,12
	+0,15 +0,05		22	25,5	62,8	36,8	77,2	0,12
34,925	+0,15 0	1 3/8	20,9	22,4	52,3	41,5	67,7	0,12
38,1	+0,12 0	1 1/2	19	23,9	57,9	45,1	71,7	0,13
	+0,12 0		22	26	62,8	43,6	76,7	0,13
	+0,1 0		22	27,1	62,8	43,7	77,2	0,13





Deep groove ball bearings with extended inner ring

Cylindrical outside surface of outer ring
Hexagonal bore

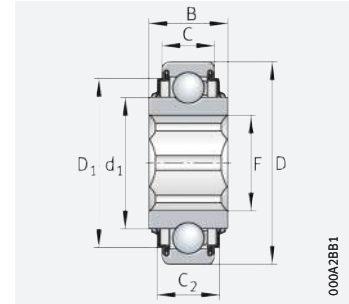

SK...KRR(-L402/70)(-AH)

000A2BB1

d = 22,225 – 44,45 mm

Main dimensions			Basic load ratings		Fatigue limit load C_{ur} N	Factor ¹⁾ f_0	Mass m ≈ kg	Designation	
d	D	B	dyn. C_r N	stat. C_{0r} N					
mm	inch								
22,225 $+0,15$ $+0,05$	$7/8$	52	25,4	14 900	7 800	395	13,8	0,18	SK014-205-KRR
25,4 $+0,15$ $+0,05$	1	62	24	20 700	11 300	570	13,8	0,27	SK100-206-KRR-AH11
31,75 $+0,15$ $+0,05$ $+0,15$ $+0,05$	$1^{1/4}$	72	25	27 500	15 300	770	13,8	0,35	SK104-207-KRR-L402/70-AH12
		80	36,5	34 500	19 800	1 010	14	0,62	SK104-208-KTT-L402/70-AH10
44,45 $+0,127$ 0	$1^{3/4}$	130	48	87 000	52 000	2 650	13,1	2,62	SK112-312-KTT-L402/70

medias ► <https://www.schaeffler.de/std/1DE2>

¹⁾ Factor f_0 for determining equivalent bearing load ► 1489 | 22.

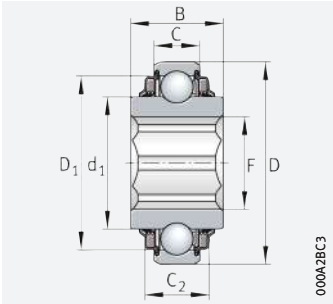

SK...KTT-L402/70(-AH)

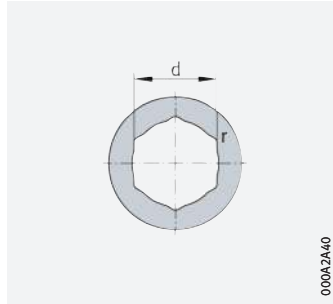

Design of bore

Width across flats of shaft		Dimensions						
		C	C ₂	d ₁	F	D ₁	r	
d								
mm	inch							
22,225	+0,15 +0,05	7/8	15	16,5	33,8	26,5	42,5	0,12
25,4	+0,15 +0,05	1	16	19	40,2	30	52	0,12
31,75	+0,15 +0,05	1 1/4	17	18,7	46,8	38	60	0,12
			18	25	52,3	38	68,4	0,12
44,45	+0,127 0	1 3/4	33	41,3	79,4	51,6	108,9	0,13





Radial insert ball bearings with rubber interliner

Spherical or cylindrical outside surface of interliner

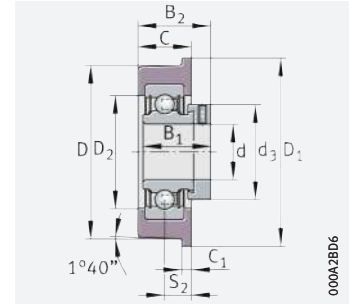

CRB..-XL

d = 12 – 50 mm

Main dimensions				Basic load ratings		Fatigue limit load	Factor ¹⁾	Mass	Designation	
d	D	B ₁	d ₃	dyn. C _r	stat. C _{0r}	C _{ur}	f ₀	m	► 1485 1.12	
			max.	N	N	N		≈ kg	► 1486 1.13	
									X-life ► 1453	Unit ²⁾
										Radial insert ball bearing ³⁾
12	47,3	28,6	28,4	10 100	4 750	241	13,1	0,15	RABRB12/47-XL-FA106	RAE12-XL-NPP-B-FA106
15	47,3	28,6	28,4	10 100	4 750	241	13,1	0,15	RABRB15/47-XL-FA106	RAE15-XL-NPP-B-FA106
	65,1	28,6	28,4	10 100	4 750	241	13,1	0,18	RCSMB15/65-XL-FA106	RAE15-XL-NPP-FA106
17	65,1	28,6	28,4	10 100	4 750	241	13,1	0,18	RCSMB17/65-XL-FA106	RAE17-XL-NPP-FA106
20	46	24,5	30	10 000	5 000	255	13,9	0,14	RCRA20/46-XL-FA106	RAE20-XL-NPP-FA106
	52,3	31	33	13 600	6 600	335	13,1	0,2	RABRB20/52-XL-FA106	RAE20-XL-NPP-B-FA106
	65,1	31	33	13 600	6 600	335	13,1	0,22	RCSMB20/65-XL-FA106	RAE20-XL-NPP-FA106
	77,5	31	33	13 600	6 600	335	13,1	0,3	CRB20/76-XL	RAE20-XL-NPP
	83,6	31	33	13 600	6 600	335	13,1	0,3	CRB20/83-XL	RAE20-XL-NPP
25	57,3	31	37,5	14 900	7 800	395	13,8	0,21	RCRB25/57-XL-FA106	RAE25-XL-NPP-FA106
	62,2	31	37,5	14 900	7 800	395	13,8	0,24	RABRB25/62-XL-FA106	RAE25-XL-NPP-B-FA106
	65,1	31	37,5	14 900	7 800	395	13,8	0,24	RCSMB25/65-XL-FA106	RAE25-XL-NPP-FA106
	71,5	31	37,5	14 900	7 800	395	13,8	0,32	CRB25/70-XL	RAE25-XL-NPP
	73	31	37,5	14 900	7 800	395	13,8	0,32	CRB25/72-XL	RAE25-XL-NPP
	83,6	31	37,5	14 900	7 800	395	13,8	0,32	CRB25/83-XL	RAE25-XL-NPP
30	62,2	26,5	42,5	14 100	8 300	420	14,8	0,3	RABRA30/62-XL-FA106	RAE30-XL-NPP-B-FA106
	65,1	26,5	42,5	14 100	8 300	420	14,8	0,32	RCSMA30/65-XL-FA106	RAE30-XL-NPP-FA106
	72,2	35,8	44	20 700	11 300	570	13,8	0,38	RABRB30/72-XL-FA106	RAE30-XL-NPP-B-FA106
	83,6	35,8	44	20 700	11 300	570	13,8	0,41	CRB30/83-XL	RAE30-XL-NPP
	93	35,8	44	20 700	11 300	570	13,8	0,41	CRB30/92-XL	RAE30-XL-NPP
35	80,2	39	55	27 500	15 300	770	13,8	0,62	RABRB35/80-XL-FA106	RAE35-XL-NPP-B-FA106
	112,3	39	55	27 500	15 300	770	13,8	0,61	CRB35/110-XL	RAE35-XL-NPP
40	85	43,8	58	34 500	19 800	1010	14	0,73	RABRB40/85-XL-FA106	RAE40-XL-NPP-B-FA106
50	100,2	43,8	69	37 500	23 200	1180	14,3	0,92	RABRB50/100-XL-FA106	RAE50-XL-NPP-B-FA106

medias ► <https://www.schaeffler.de/std/1DE3>

- Factor f₀ for determining equivalent bearing load ► 1489 | 22.
- Operating temperature from -20 °C to +85 °C.
- Permissible speeds of radial insert ball bearings ► 1476.
- Also available by agreement in NBR80.

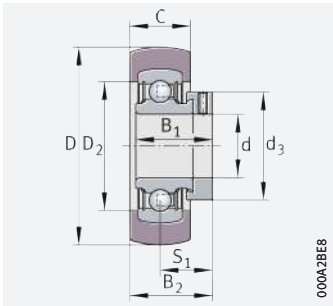

RABRA..-XL-FA106, RABRB..-XL-FA106

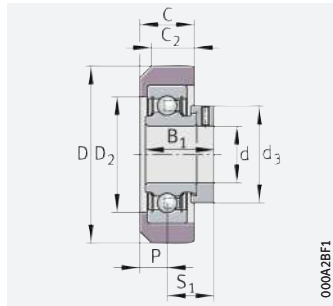

RARA..-XL-FA106, RARB..-XL-FA106

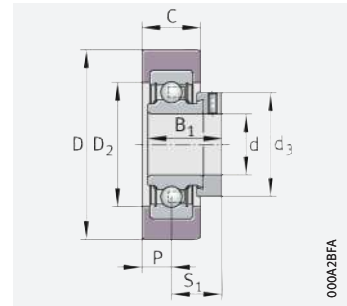

RCSMA..-XL-FA106, RCSMB..-XL-FA106

Dimensions

Rubber interliner	
Hardness	Load carrying capacity
Shore A	C _G
°	N

d	D ₁	C	C ₂	C ₁	S ₁	D ₂	P	S ₂	B ₂	Shore A	C _G
12	-	17,6	-	-	22,1	33,5	-	-	30,9	70	840
15	-	18	-	-	22,1	33,5	-	-	31,1	70	840
	-	25,4	-	-	22,1	35	12,7	-	-	70	900
17	-	25,4	-	-	22,1	35	12,7	-	-	70	900
20	-	18,3	16	-	18,6	35	10	-	-	70	900
	-	17,6	-	-	23,5	39	-	-	32,3	70	1160
	-	25,4	-	-	23,5	40	12,7	-	-	70	1200
	80	25,4	-	5	-	40	-	12,5	36	80	750
	87,4	25,4	-	4,8	-	40	-	12,7	36,2	80	750
25	-	19,8	17,5	-	23,5	44,5	9,8	-	-	70	1400
	-	20,8	-	-	23,5	44,5	-	-	33,9	70 ⁴⁾	1390
	-	25,4	-	-	23,5	46	12,7	-	-	70	1400
	76	25	-	5	-	46	-	12,5	36	80	1000
	80	25	-	5	-	46	-	12,5	36	80	1000
	87,4	25,4	-	4,8	-	46	-	12,7	36,2	80	1000
30	-	20,8	-	-	20	47	-	-	30,4	70	1390
	-	25,4	-	-	20	47,6	15	-	-	70	1400
	-	23	-	-	26,7	54	-	-	38,2	70 ⁴⁾	1980
	87,4	28	-	4,8	-	56	-	14	40,7	80	1400
	98	28	-	5	-	56	-	14	40,7	80	1400
35	-	24	-	-	29,4	62	-	-	41,4	70	2700
	120	30	-	5	-	64	-	15	44,4	80	1500
40	-	27	-	-	32,7	70	-	-	46,3	70 ⁴⁾	3500
50	-	30	-	-	32,7	80	-	-	47,7	70 ⁴⁾	4100





Radial insert ball bearings with steel aligning ring

With eccentric locking collar or with bore for fit

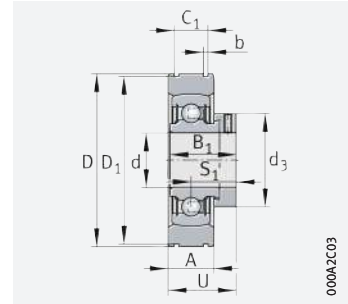

PE..-XL

000A2C03

d = 20 – 40 mm

Main dimensions				Basic load ratings		Fatigue limit load	Factor ¹⁾	Mass	Designation	
d	D ²⁾	B ₁	d ₃ max.	dyn. C _r N	stat. C _{0r} N	C _{ur} N	f ₀	m ≈ kg	Unit ⁵⁾	Radial insert ball bearing
20	55	31	33	13 600	6 600	335	13,1	0,24	PE20-XL	RAE20-XL-NPP-B
25	62	31	37,5	14 900	7 800	395	13,8	0,31	PE25-XL	RAE25-XL-NPP-B
30	72	35,8	44	20 700	11 300	570	13,8	0,48	PE30-XL	RAE30-XL-NPP-B
35	80	39	55	27 500	15 300	770	13,8	0,69	PE35-XL	RAE35-XL-NPP-B
40	90	43,8	58	34 500	19 800	1 010	14	0,88	PE40-XL	RAE40-XL-NPP-B

Designation
 ▶ 1485 | 1.12
 ▶ 1486 | 1.13
 X-life ▶ 1453

Main dimensions			Basic load ratings		Fatigue limit load	Factor ¹⁾	Mass	Designation	
d	D ²⁾	B	dyn. C _r N	stat. C _{0r} N	C _{ur} N	f ₀	m ≈ kg	Unit ⁵⁾	Radial insert ball bearing
20	55	14	13 600	6 600	335	13,1	0,19	BE20-XL	204-XL-NPP-B
25	62	15	14 900	7 800	395	13,8	0,25	BE25-XL	205-XL-NPP-B
30	72	16	20 700	11 300	570	13,8	0,37	BE30-XL	206-XL-NPP-B
35	80	17	27 500	15 300	770	13,8	0,45	BE35-XL	207-XL-NPP-B
40	90	18	34 500	19 800	1 010	14	0,63	BE40-XL	208-XL-NPP-B

Designation
 ▶ 1485 | 1.12
 ▶ 1486 | 1.13
 X-life ▶ 1453

medias ▶ <https://www.schaeffler.de/std/1DE4>

- Factor f₀ for determining equivalent bearing load ▶ 1489 | 22.
- Before splitting, dimension D corresponds to tolerance class Normal in accordance with ISO 492.
- Permissible speeds of radial insert ball bearings RAE..NPP-B ▶ 1476.
- Annular slot tolerances to DIN 616 (for snap rings to DIN 5417).
- Permissible speeds of self-aligning deep groove ball bearings 2..NPP-B ▶ 1536.

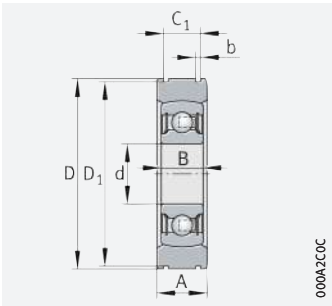

000A2C0C

BE...XL

Dimensions

d	A	C ₁ ⁴⁾	b ⁴⁾	D ₁ ⁴⁾	S ₁	U
		+0,2	+0,3	-0,5		
20	16	11,2	1,35	52,6	23,5	31,5
25	17	11,2	1,9	59,6	23,5	32
30	21	14,4	1,9	68,8	26,8	37,2
35	21	14,4	1,9	76,8	29,5	40
40	25	15,4	2,7	86,8	32,8	45,2

Dimensions

d	A	C ₁ ⁴⁾	b ⁴⁾	D ₁ ⁴⁾	U
		+0,2	+0,3	-0,5	
20	16	11,2	1,35	52,6	-
25	17	11,2	1,9	59,6	-
30	21	14,4	1,9	68,8	-
35	21	14,4	1,9	76,8	-
40	25	15,4	2,7	86,8	-





Corrosion-resistant radial insert ball bearings, VA design

With grub screws in inner ring
Spherical outside surface of outer ring

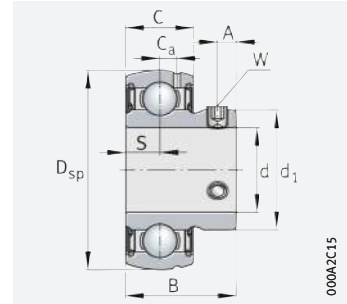

SUB

d = 20 – 50 mm

Main dimensions			Basic load ratings		Fatigue limit load	Factor ¹⁾	Mass	Designation ²⁾³⁾
d	D _{sp}	B	dyn. C _r N	stat. C _{0r} N	C _{ur} N	f ₀	m ≈ kg	▶ 1485 1.12 ▶ 1486 1.13
20	47	26	12 300	6 300	300	13,1	0,14	SUB204
25	52	28	13 400	7 500	360	13,8	0,17	SUB205
30	62	30,5	18 700	10 700	510	13,8	0,26	SUB206
35	72	35,45	24 600	14 600	700	13,8	0,41	SUB207
40	80	39,45	31 500	18 900	910	14	0,52	SUB208
45	85	41,5	31 500	19 400	930	14,3	0,6	SUB209
50	90	43,5	33 500	22 100	1 060	14,3	0,67	SUB210

medias ▶ <https://www.schaeffler.de/std/1DE5>

- Factor f₀ for determining equivalent bearing load ▶ 1489 | 22.
- Speed limits for radial insert ball bearings ▶ 1476.
- Lubrication groove and two lubrication holes in the outer ring.



Dimensions						Width across flats
d	C	S	d ₁	C _a	A	W
20	16	8	29,05	4	4,5	2,5
25	17	8,5	34,03	4,15	5	2,5
30	19	9,5	40,31	5	5,8	3
35	20	10	47,4	5,7	6,1	3
40	21	10,5	52,83	5,9	8	4
45	22	11	57,3	6,5	8	4
50	23	11,5	62,92	6,5	9	5





Corrosion-resistant radial insert ball bearings, VA design

With grub screws in inner ring
Spherical outside surface of outer ring
With extended inner ring

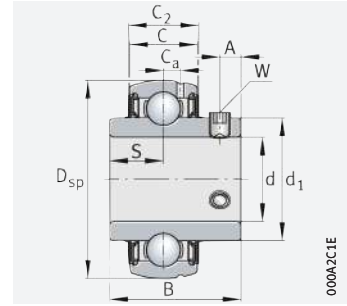

SUC

d = 12 – 50 mm

Main dimensions			Basic load ratings		Fatigue limit load	Factor ¹⁾	Mass	Designation ²⁾
d	D _{sp}	B	dyn. C _r N	stat. C _{0r} N	C _{ur} N	f ₀	m ≈ kg	► 1485 1.12 ► 1486 1.13
12	40	25	9 200	4 550	218	13,1	0,11	SUC201 ³⁾
15	40	25	9 200	4 550	218	13,1	0,1	SUC202 ³⁾
17	40	25	9 200	4 550	218	13,1	0,08	SUC203 ³⁾
20	47	31	12 300	6 300	300	13,1	0,16	SUC204 ⁴⁾
25	52	34,1	13 400	7 500	360	13,8	0,2	SUC205 ⁴⁾
30	62	38,1	18 700	10 700	510	13,8	0,31	SUC206 ⁴⁾
35	72	42,9	24 600	14 600	700	13,8	0,47	SUC207 ⁴⁾
40	80	49,2	31 500	18 900	910	14	0,62	SUC208 ⁴⁾
45	85	49,2	31 500	19 400	930	14,3	0,67	SUC209 ⁴⁾
50	90	51,6	33 500	22 100	1 060	14,3	0,78	SUC210 ⁴⁾

medias ► <https://www.schaeffler.de/std/1DE6>

¹⁾ Factor f₀ for determining equivalent bearing load ► 1489 | 22.

²⁾ Speed limits for radial insert ball bearings ► 1476.

³⁾ Two lubrication holes in the outer ring.

⁴⁾ Lubrication groove and two lubrication holes in the outer ring.



Dimensions							Width across flats
d	C	C ₂ max.	S	d ₁	C _a	A	W
12	12	12,6	9,6	23,9	3,4	4	2,5
15	12	12,6	9,6	23,9	3,4	4	2,5
17	12	12,6	9,6	23,9	3,4	4	2,5
20	16	16,6	12,7	29,05	4	5	2,5
25	17	17,6	14,3	34,03	4,15	5	2,5
30	19	19,6	15,9	40,31	5	6	3
35	20	20,6	17,5	47,4	5,7	6,5	3
40	21	21,6	19	52,83	5,9	8	4
45	22	22,6	19	57,3	6,5	8	4
50	23	23,6	19	62,92	6,5	9	5





Corrosion-resistant radial insert ball bearings, VA design

With eccentric locking collar
Spherical outside surface of outer ring

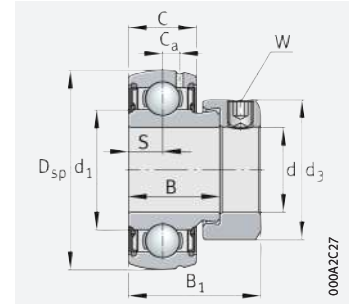

SUG

d = 20 – 50 mm

Main dimensions				Basic load ratings		Fatigue limit load	Factor ¹⁾	Mass	Designation ²⁾³⁾
d	D _{sp}	B ₁	d ₃ max.	dyn. C _r N	stat. C _{0r} N	C _{ur} N	f ₀	m ≈ kg	► 1485 1.12 ► 1486 1.13
20	47	31,5	33	12 300	6 300	300	13,1	0,17	SUG204
25	52	32	37,5	13 400	7 500	360	13,8	0,2	SUG205
30	62	36,3	44	18 700	10 700	510	13,8	0,31	SUG206
35	72	39,5	55	24 600	14 600	700	13,8	0,51	SUG207
40	80	43,8	58	31 500	18 900	910	14	0,6	SUG208
45	85	43,8	63	31 500	19 400	930	14,3	0,7	SUG209
50	90	44,3	69	33 500	22 100	1 060	14,3	0,77	SUG210

medias ► <https://www.schaeffler.de/std/1DE7>

- Factor f_0 for determining equivalent bearing load ► 1489 | 22.
- Speed limits for radial insert ball bearings ► 1476.
- Lubrication groove and two lubrication holes in the outer ring.



Dimensions							Width across flats
d	D _{sp}	C	B	S	d ₁	C _a	W
20	47	16	21,9	8	29,05	4	3
25	52	17	22,4	8,5	34,03	4,15	3
30	62	19	24,3	9,5	40,31	5	4
35	72	20	25,9	10	47,4	5,7	5
40	80	21	30,2	11	52,83	5,9	5
45	85	22	30,2	11	57,3	6,5	5
50	90	23	30,7	11	62,92	6,5	5





Corrosion-resistant radial insert ball bearings, with Corrotect coating

With eccentric locking collar
Spherical outside surface of outer ring

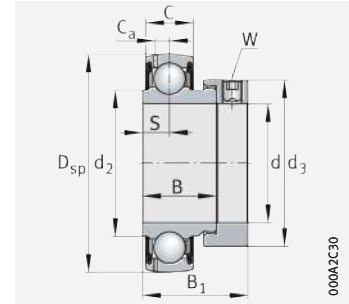

GRAE..-XL-NPP-B-FA125

000A2C30

d = 20 – 60 mm

Main dimensions				Basic load ratings		Fatigue limit load	Factor ¹⁾	Mass	Designation ²⁾
d	D _{sp}	B ₁	d ₃	dyn. C _r	stat. C _{0r}	C _{ur}	f ₀	m	
			max.	N	N	N		≈ kg	▶ 1485 1.12 ▶ 1486 1.13 X-life ▶ 1453
20	47	31	33	13 600	6 600	335	13,1	0,16	GRAE20-XL-NPP-B-FA125
	47	43,7	33	13 600	6 600	335	13,1	0,19	GE20-XL-KRR-B-FA125
25	52	31	37,5	14 900	7 800	395	13,8	0,19	GRAE25-XL-NPP-B-FA125
	52	44,5	37,5	14 900	7 800	395	13,8	0,25	GE25-XL-KRR-B-FA125
30	62	35,8	44	20 700	11 300	570	13,8	0,32	GRAE30-XL-NPP-B-FA125
	62	48,5	44	20 700	11 300	570	13,8	0,39	GE30-XL-KRR-B-FA125
35	72	39	55	27 500	15 300	770	13,8	0,48	GRAE35-XL-NPP-B-FA125
	72	51,3	55	27 500	15 300	770	13,8	0,55	GE35-XL-KRR-B-FA125
40	80	43,8	58	34 500	19 800	1010	14	0,62	GRAE40-XL-NPP-B-FA125
	80	56,5	58	34 500	19 800	1010	14	0,73	GE40-XL-KRR-B-FA125
45	85	43,8	63	34 500	20 400	1030	14,3	0,69	GRAE45-XL-NPP-B-FA125
	85	56,5	63	34 500	20 400	1030	14,3	0,83	GE45-XL-KRR-B-FA125
50	90	43,8	69	37 500	23 200	1180	14,3	0,77	GRAE50-XL-NPP-B-FA125
	90	62,8	69	37 500	23 200	1180	14,3	0,99	GE50-XL-KRR-B-FA125
60	110	53,1	84	56 000	36 000	1820	14,3	1,4	GRAE60-XL-NPP-B-FA125

medias ▶ <https://www.schaeffler.de/std/1DE8>

¹⁾ Factor f₀ for determining equivalent bearing load ▶ 1489 | 22.

²⁾ Speed limits for radial insert ball bearings ▶ 1476.

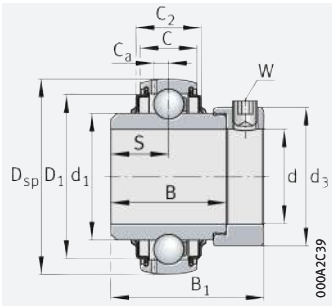

GE..XL-KRR-B-FA125

Dimensions									Width across flats W
d	C	C ₂	B	S	d ₁	d ₂	D ₁	C _a	W
20	14	–	21,4	7,5	–	26,9	–	4	3
	14	16,6	34,1	17,1	27,6	–	37,4	4	3
25	15	–	21,4	7,5	–	30,5	–	3,9	3
	15	16,7	34,9	17,5	33,8	–	42,5	4,1	3
30	18	–	23,8	9	–	37,4	–	4,7	4
	18	20,7	36,5	18,3	40,2	–	52	4,7	4
35	19	–	25,4	9,5	–	44,6	–	5,6	5
	19	22,5	37,7	18,8	46,8	–	60,3	5,6	5
40	21	–	30,2	11	–	49,4	–	6,4	5
	21	23,5	42,9	21,4	52,3	–	68,3	6,4	5
45	22	–	30,2	11	–	54,3	–	6,4	5
	22	26,4	42,9	21,4	57,9	–	72,3	6,4	5
50	22	–	30,2	11	–	59,4	–	6,9	5
	22	26,4	49,2	24,6	62,8	–	77,3	6,9	5
60	24	–	37,1	13,5	–	72	–	7,2	5





Black Series, radial insert ball bearings in accordance with JIS

With grub screws in inner ring
Spherical outside surface of outer ring

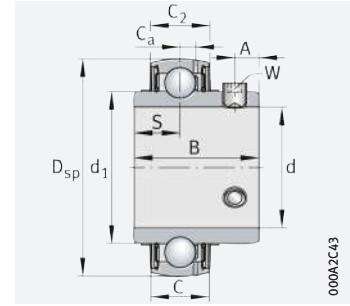

UC

d = 12 – 35 mm

Main dimensions			Basic load ratings		Fatigue limit load	Factor ¹⁾	Mass	Designation ²⁾	
d	D _{sp}	B	dyn. C _r	stat. C _{0r}	C _{ur}	f ₀	m	► 1485 1.12 ► 1486 1.13	
mm	inch		N	N	N		≈ kg		
12	–	47	31	13 600	6 600	335	13,1	0,2	UC201
12,7	1/2	47	31	13 600	6 600	335	13,1	0,2	UC201-08
14,288	9/16	47	31	13 600	6 600	335	13,1	0,19	UC202-09
15	–	47	31	13 600	6 600	335	13,1	0,18	UC202
15,875	5/8	47	31	13 600	6 600	335	13,1	0,18	UC202-10
17	–	47	31	13 600	6 600	335	13,1	0,17	UC203
17,463	11/16	47	31	13 600	6 600	335	13,1	0,17	UC203-11
19,05	3/4	47	31	13 600	6 600	335	13,1	0,16	UC204-12
20	–	47	31	13 600	6 600	335	13,1	0,15	UC204
20,638	13/16	52	34,1	14 900	7 800	395	13,8	0,24	UC205-13
22,225	7/8	52	34,1	14 900	7 800	395	13,8	0,22	UC205-14
23,813	15/16	52	34,1	14 900	7 800	395	13,8	0,21	UC205-15
25	–	52	34,1	14 900	7 800	395	13,8	0,2	UC205
25,4	1	52	34,1	14 900	7 800	395	13,8	0,19	UC205-16
26,988	1 1/16	62	38,1	20 700	11 300	570	13,8	0,35	UC206-17
28,575	1 1/8	62	38,1	20 700	11 300	570	13,8	0,33	UC206-18
30	–	62	38,1	20 700	11 300	570	13,8	0,31	UC206
30,163	1 3/16	62	38,1	20 700	11 300	570	13,8	0,31	UC206-19
31,75	1 1/4	62	38,1	20 700	11 300	570	13,8	0,29	UC206-20
31,75	1 1/4	72	42,9	27 500	15 300	770	13,8	0,52	UC207-20
33,338	1 5/16	72	42,9	27 500	15 300	770	13,8	0,5	UC207-21
34,925	1 3/8	72	42,9	27 500	15 300	770	13,8	0,47	UC207-22
35	–	72	42,9	27 500	15 300	770	13,8	0,47	UC207

medias ► <https://www.schaeffler.de/std/1DE9>

- Factor f₀ for determining equivalent bearing load ► 1489 | 22.
- Speed limits for radial insert ball bearings ► 1476.



Dimensions								Width across flats	
d		C	C ₂	S	d ₁	C _a	A	W	
mm	inch							mm	inch
12	–	17	16,8	12,7	27,56	4,2	5	3	–
12,7	1/2	17	16,8	12,7	27,56	4,2	5	–	1/8
14,288	9/16	17	16,8	12,7	27,56	4,2	5	–	1/8
15	–	17	16,8	12,7	27,56	4,2	5	3	–
15,875	5/8	17	16,8	12,7	27,56	4,2	5	–	1/8
17	–	17	16,8	12,7	27,56	4,2	5	3	–
17,463	11/16	17	16,8	12,7	27,56	4,2	5	–	1/8
19,05	3/4	17	16,8	12,7	27,56	4,2	5	–	1/8
20	–	17	16,8	12,7	27,56	4,2	5	3	–
20,638	13/16	17	17,6	14,3	33,83	4,2	5	–	1/8
22,225	7/8	17	17,6	14,3	33,83	4,2	5	–	1/8
23,813	15/16	17	17,6	14,3	33,83	4,2	5	–	1/8
25	–	17	17,6	14,3	33,83	4,2	5	3	–
25,4	1	17	17,6	14,3	33,83	4,2	5	–	1/8
26,988	11/16	19	19,6	15,9	40,2	5	5	–	1/8
28,575	11/8	19	19,6	15,9	40,2	5	5	–	1/8
30	–	19	19,6	15,9	40,2	5	5	3	–
30,163	13/16	19	19,6	15,9	40,2	5	5	–	1/8
31,75	11/4	19	19,6	15,9	40,2	5	5	–	1/8
31,75	11/4	20	20,6	17,5	46,84	5,7	7	–	5/32
33,338	15/16	20	20,6	17,5	46,84	5,7	7	–	5/32
34,925	13/8	20	20,6	17,5	46,84	5,7	7	–	5/32
35	–	20	20,6	17,5	46,84	5,7	7	4	–





Black Series, radial insert ball bearings in accordance with JIS

With grub screws in inner ring
Spherical outside surface of outer ring

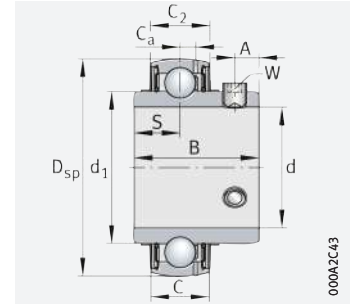

UC

000A2C43

d = 36,513 – 61,913 mm

Main dimensions			Basic load ratings		Fatigue limit load	Factor ¹⁾	Mass	Designation ²⁾	
d		D _{sp}	B	dyn. C _r	stat. C _{0r}	C _{ur}	f ₀	m	▶ 1485 1.12 ▶ 1486 1.13
mm	inch			N	N	N		≈ kg	
36,513	1 ⁷ / ₁₆	72	42,9	27 500	15 300	770	13,8	0,44	UC207-23
38,1	1 ¹ / ₂	80	49,2	34 500	19 800	1 010	14	0,66	UC208-24
39,688	1 ⁹ / ₁₆	80	49,2	34 500	19 800	1 010	14	0,63	UC208-25
40	–	80	49,2	34 500	19 800	1 010	14	0,62	UC208
41,275	1 ⁵ / ₈	85	49,2	34 500	20 400	1 030	14,3	0,79	UC209-26
42,863	1 ¹¹ / ₁₆	85	49,2	34 500	20 400	1 030	14,3	0,75	UC209-27
44,45	1 ³ / ₄	85	49,2	34 500	20 400	1 030	14,3	0,71	UC209-28
45	–	85	49,2	34 500	20 400	1 030	14,3	0,69	UC209
46,038	1 ¹³ / ₁₆	90	51,6	37 500	23 200	1 180	14,3	0,92	UC210-29
47,625	1 ⁷ / ₈	90	51,6	37 500	23 200	1 180	14,3	0,87	UC210-30
49,213	1 ¹⁵ / ₁₆	90	51,6	37 500	23 200	1 180	14,3	0,82	UC210-31
50	–	90	51,6	37 500	23 200	1 180	14,3	0,8	UC210
50,8	2	90	51,6	37 500	23 200	1 180	14,3	0,77	UC210-32
50,8	2	100	55,6	46 000	29 000	1 480	14,3	1,22	UC211-32
52,388	2 ¹ / ₁₆	100	55,6	46 000	29 000	1 480	14,3	1,17	UC211-33
53,975	2 ¹ / ₈	100	55,6	46 000	29 000	1 480	14,3	1,11	UC211-34
55	–	100	55,6	46 000	29 000	1 480	14,3	1,07	UC211
55,563	2 ³ / ₁₆	100	55,6	46 000	29 000	1 480	14,3	1,05	UC211-35
57,15	2 ¹ / ₄	110	65,1	56 000	36 000	1 820	14,3	1,62	UC212-36
58,738	2 ⁵ / ₁₆	110	65,1	56 000	36 000	1 820	14,3	1,55	UC212-37
60	–	110	65,1	56 000	36 000	1 820	14,3	1,49	UC212
60,325	2 ³ / ₈	110	65,1	56 000	36 000	1 820	14,3	1,48	UC212-38
61,913	2 ⁷ / ₁₆	110	65,1	56 000	36 000	1 820	14,3	1,4	UC212-39

medias ▶ <https://www.schaeffler.de/std/1DEA>

1) Factor f₀ for determining equivalent bearing load ▶ 1489 | 22.

2) Speed limits for radial insert ball bearings ▶ 1476.



Dimensions								Width across flats	
d		C	C ₂	S	d ₁	C _a	A	W	
mm	inch							mm	inch
36,513	17/16	20	20,6	17,5	46,84	5,7	7	–	5/32
38,1	1 1/2	21	21,6	19	52,27	6,2	8	–	5/32
39,688	19/16	21	21,6	19	52,27	6,2	8	–	5/32
40	–	21	21,6	19	52,27	6,2	8	4	–
41,275	15/8	22	22,6	19	57,91	6,3	8	–	5/32
42,863	111/16	22	22,6	19	57,91	6,3	8	–	5/32
44,45	13/4	22	22,6	19	57,91	6,3	8	–	5/32
45	–	22	22,6	19	57,91	6,3	8	4	–
46,038	113/16	24	24,6	19	62,84	6,5	10	–	3/16
47,625	17/8	24	24,6	19	62,84	6,5	10	–	3/16
49,213	115/16	24	24,6	19	62,84	6,5	10	–	3/16
50	–	24	24,6	19	62,84	6,5	10	5	–
50,8	2	24	24,6	19	62,84	6,5	10	–	3/16
50,8	2	25	25,6	22,2	69,77	7	10	–	3/16
52,388	21/16	25	25,6	22,2	69,77	7	10	–	3/16
53,975	21/8	25	25,6	22,2	69,77	7	10	–	3/16
55	–	25	25,6	22,2	69,77	7	10	5	–
55,563	23/16	25	25,6	22,2	69,77	7	10	–	3/16
57,15	21/4	27	27,6	25,4	76,48	7,4	10	–	3/16
58,738	25/16	27	27,6	25,4	76,48	7,4	10	–	3/16
60	–	27	27,6	25,4	76,48	7,4	10	5	–
60,325	23/8	27	27,6	25,4	76,48	7,4	10	–	3/16
61,913	27/16	27	27,6	25,4	76,48	7,4	10	–	3/16





Black Series, radial insert ball bearings in accordance with JIS

With grub screws in inner ring
Spherical outside surface of outer ring

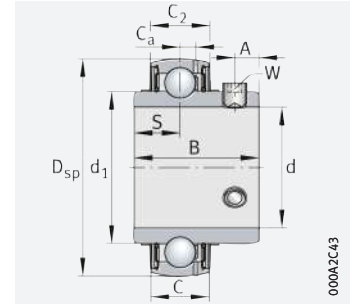

UC

d = 63,5 – 90 mm

Main dimensions			Basic load ratings		Fatigue limit load	Factor ¹⁾	Mass	Designation ²⁾	
d		D _{sp}	B	dyn. C _r	stat. C _{0r}	C _{ur}	f ₀	m	▶ 1485 1.12 ▶ 1486 1.13
mm	inch			N	N	N		≈ kg	
63,5	2 1/2	120	65,1	61 000	40 000	2 030	14,3	1,79	UC213-40
65	–	120	65,1	61 000	40 000	2 030	14,3	1,72	UC213
65,088	2 9/16	120	65,1	61 000	40 000	2 030	14,3	1,71	UC213-41
66,675	2 5/8	125	74,6	66 000	44 000	2 230	14,4	2,17	UC214-42
68,263	2 11/16	125	74,6	66 000	44 000	2 230	14,4	2,07	UC214-43
69,85	2 3/4	125	74,6	66 000	44 000	2 230	14,4	1,97	UC214-44
70	–	125	74,6	66 000	44 000	2 230	14,4	1,96	UC214
71,438	2 13/16	130	77,8	66 000	44 500	2 240	14,7	2,39	UC215-45
73,025	2 7/8	130	77,8	66 000	44 500	2 240	14,7	2,28	UC215-46
74,613	2 15/16	130	77,8	66 000	44 500	2 240	14,7	2,17	UC215-47
75	–	130	77,8	66 000	44 500	2 240	14,7	2,14	UC215
76,2	3	130	77,8	66 000	44 500	2 240	14,7	2,06	UC215-48
77,788	3 1/16	140	82,6	76 000	54 000	2 600	14,6	2,88	UC216-49
79,375	3 1/8	140	82,6	76 000	54 000	2 600	14,6	2,76	UC216-50
80	–	140	82,6	76 000	54 000	2 600	14,6	2,71	UC216
80,963	3 3/16	140	82,6	76 000	54 000	2 600	14,6	2,63	UC216-51
82,55	3 1/4	150	85,7	88 000	64 000	2 950	14,7	3,62	UC217-52
84,138	3 5/16	150	85,7	88 000	64 000	2 950	14,7	3,48	UC217-53
85	–	150	85,7	88 000	64 000	2 950	14,7	3,41	UC217
87,313	3 7/16	150	85,7	88 000	64 000	2 950	14,7	3,2	UC217-55
88,9	3 1/2	160	96	102 000	72 000	3 250	14,5	4,2	UC218-56
90	–	160	96	102 000	72 000	3 250	14,5	4,08	UC218

medias ▶ <https://www.schaeffler.de/std/1DEB>

- Factor f₀ for determining equivalent bearing load ▶ 1489 | 22.
- Speed limits for radial insert ball bearings ▶ 1476.



Dimensions								Width across flats	
d		C	C ₂	S	d ₁	C _a	A	W	
mm	inch							mm	inch
63,5	2 ^{1/2}	28	29,4	25,4	80,85	8,2	12	–	1/4
65	–	28	29,4	25,4	80,85	8,2	12	6	–
65,088	2 ^{9/16}	28	29,4	25,4	80,85	8,2	12	–	1/4
66,675	2 ^{5/8}	30	31,4	30,2	85,2	8,5	12	–	1/4
68,263	2 ^{11/16}	30	31,4	30,2	85,2	8,5	12	–	1/4
69,85	2 ^{3/4}	30	31,4	30,2	85,2	8,5	12	–	1/4
70	–	30	31,4	30,2	85,2	8,5	12	6	–
71,438	2 ^{13/16}	32	33,4	33,3	90	8,5	12	–	1/4
73,025	2 ^{7/8}	32	33,4	33,3	90	8,5	12	–	1/4
74,613	2 ^{15/16}	32	33,4	33,3	90	8,5	12	–	1/4
75	–	32	33,4	33,3	90	8,5	12	6	–
76,2	3	32	33,4	33,3	90	8,5	12	–	1/4
77,788	3 ^{1/16}	33	34,4	33,3	97	9,3	14	–	1/4
79,375	3 ^{1/8}	33	34,4	33,3	97	9,3	14	–	1/4
80	–	33	34,4	33,3	97	9,3	14	6	–
80,963	3 ^{3/16}	33	34,4	33,3	97	9,3	14	–	1/4
82,55	3 ^{1/4}	35	36,4	34,1	104,09	10	14	–	1/4
84,138	3 ^{5/16}	35	36,4	34,1	104,09	10	14	–	1/4
85	–	35	36,4	34,1	104,09	10	14	6	–
87,313	3 ^{7/16}	35	36,4	34,1	104,09	10	14	–	1/4
88,9	3 ^{1/2}	38	39,4	39,7	109,4	11	15	–	1/4
90	–	38	39,4	39,7	109,4	11	15	6	–





Black Series, radial insert ball bearings in accordance with JIS

With adapter sleeve

Spherical outside surface of outer ring

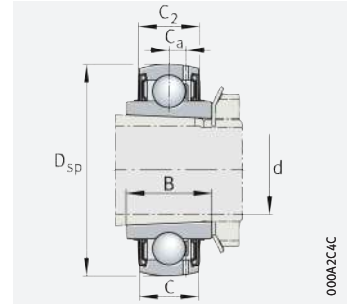

UK

d = 20 – 80 mm

Main dimensions			Basic load ratings		Fatigue limit load	Factor ¹⁾	Mass	Designation ²⁾
d	D _{sp}	B	dyn. C _r N	stat. C _{0r} N	C _{ur} N	f ₀	m ≈ kg	▶ 1485 1.12 ▶ 1486 1.13
20	52	23	14 900	7 800	395	13,8	0,25	UK205
25	62	26	20 700	11 300	570	13,8	0,37	UK206
30	72	29	27 500	15 300	770	13,8	0,54	UK207
35	80	31	34 500	19 800	1 010	14	0,7	UK208
40	85	32	34 500	20 400	1 030	14,3	0,83	UK209
45	90	34	37 500	23 200	1 180	14,3	0,98	UK210
50	100	36	46 000	29 000	1 480	14,3	1,24	UK211
55	110	40	56 000	36 000	1 820	14,3	1,58	UK212
60	120	41	61 000	40 000	2 030	14,3	1,88	UK213
65	130	44,5	66 000	44 500	2 240	14,7	2,62	UK215
70	140	46	76 000	54 000	2 600	14,6	3,23	UK216
75	150	48	88 000	64 000	2 950	14,7	3,9	UK217
80	160	51	102 000	72 000	3 250	14,5	4,62	UK218

medias ▶ <https://www.schaeffler.de/std/1DEC>

- Factor f₀ for determining equivalent bearing load ▶ 1489 | 22.
- Speed limits for radial insert ball bearings ▶ 1476.
- Radial insert ball bearings UK are supplied with an adapter sleeve H..X.

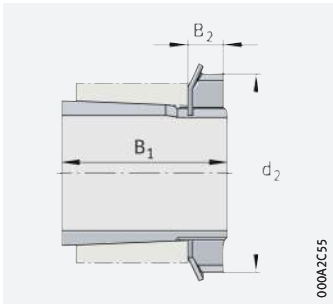

Complete adapter sleeve³⁾

Dimensions				Adapter sleeve Complete							
d	C	C ₂	C _a	Designation				Mass m ≈ kg	Dimensions		
				Adapter sleeve Complete	Sleeve	Locknut	Tab washer		B ₁	B ₂	d ₂ max.
20	17	17,6	4,2	H2305X	A2305X	AN05	AW05X	0,1	35	8	38
25	19	19,6	5	H2306X	A2306X	AN06	AW06X	0,13	38	8	45
30	20	20,6	5,7	H2307X	A2307X	AN07	AW07X	0,18	43	9	52
35	21	21,6	6,2	H2308X	A2308X	AN08	AW08X	0,23	46	10	58
40	22	22,6	6,3	H2309X	A2309X	AN09	AW09X	0,31	50	11	65
45	24	24,6	6,5	H2310X	A2310X	AN10	AW10X	0,38	55	12	70
50	25	25,6	7	H2311X	A2311X	AN11	AW11X	0,45	59	12	75
55	27	27,6	7,4	H2312X	A2312X	AN12	AW12X	0,5	62	13	80
60	28	29,4	8,2	H2313X	A2313X	AN13	AW13X	0,58	65	14	85
65	32	33,4	8,5	H2315X	A2315X	AN15	AW15X	1,1	73	15	98
70	33	34,4	9,3	H2316X	A2316X	AN16	AW16X	1,33	78	17	105
75	35	36,4	10	H2317X	A2317X	AN17	AW17X	1,51	82	18	110
80	38	39,4	11	H2318X	A2318X	AN18	AW18X	1,77	86	18	120



Bearing housings

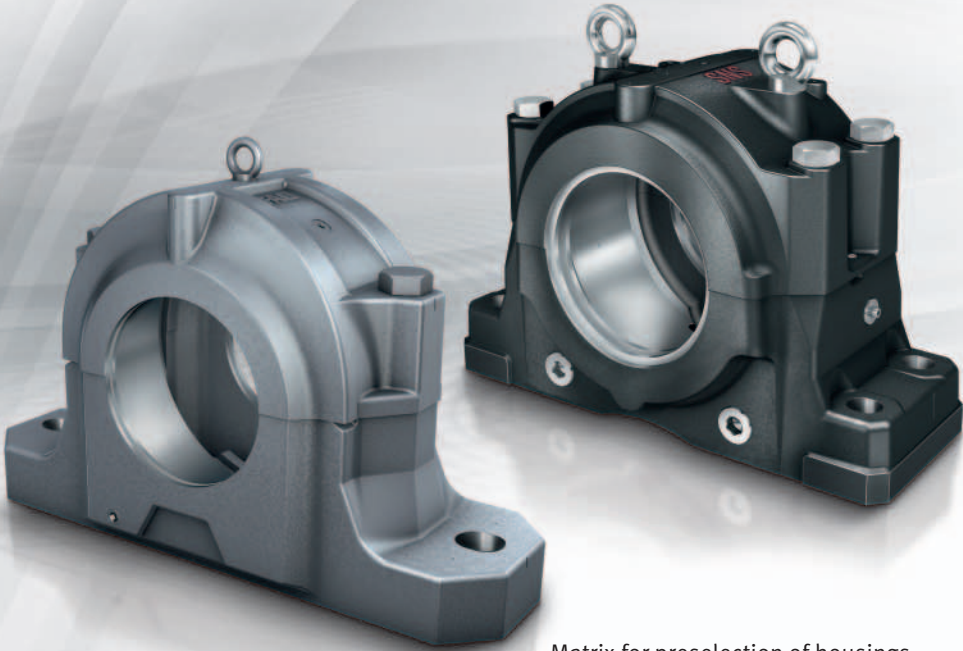



Matrix for preselection of housings 1568

1 Principles **1570**

- 1.1 Housing concepts 1570
- 1.2 Locating and non-locating bearing concepts 1571
- 1.3 Materials 1573
- 1.4 Corrosion protection 1574
- 1.5 Selection wizard for bearing housings 1574



2 Split plummer block housings SNV **1575**

- 2.1 Housing design 1575
- 2.2 Suitable bearings 1576
- 2.3 Materials, corrosion protection 1577

2.4	Locating and non-locating bearings	1577
2.5	Load carrying capacity	1578
2.6	Lubrication	1580
2.7	Sealing	1586
2.8	Dimensions, tolerances	1590
2.9	Housing configurations	1590
2.10	Structure of housing designation	1592
2.11	Mounting and dismounting	1596
2.12	Legal notice regarding data freshness	1596
2.13	Further information	1597
Product tables		1598
	<i>Split plummer block housings SNV, tapered bore, adapter sleeve</i>	1598
	<i>Split plummer block housings SNV, cylindrical bore</i>	1610

3 Split plummer block housings SNS 1624

3.1	Housing design	1624
3.2	Suitable bearings	1627
3.3	Materials, corrosion protection	1628
3.4	Locating and non-locating bearings	1628
3.5	Load carrying capacity	1629
3.6	Lubrication	1632
3.7	Sealing	1636
3.8	Dimensions, tolerances	1640
3.9	Housing configurations	1640
3.10	Structure of housing designation	1644

3.11	Mounting and dismounting	1647
3.12	Legal notice regarding data freshness	1649
3.13	Further information	1649
Product tables		1650
	<i>Split plummer block housings SNS, tapered bore, adapter sleeve</i>	1650
	<i>Split plummer block housings SNS, cylindrical bore</i>	1660

4 Other bearing housings 1668

4.1	Split plummer block housings S30	1668
4.2	Split plummer block housings SAF	1670
4.3	Split plummer block housings RLE	1673
4.4	Split plummer block housings KPGZ	1675
4.5	Split plummer block housings LOE	1677
4.6	Plummer block housing units VRE3	1679
4.7	Unsplit plummer block housings BND	1681
4.8	Take-up housings SPA	1684
4.9	Flanged housings F112	1686
4.10	Flanged housings F5	1687
4.11	Legal notice regarding data freshness	1689
4.12	Further information	1689



Matrix for preselection of housings

The matrix gives an overview of the design features of bearing housings and the bearing types suitable for the housings.

It can be used to make a preliminary assessment of whether a housing is fundamentally suitable for the envisaged application.

The additional information provided in the product chapter (see column "detailed information") must, however, be observed in addition to this overview in selection of the housing.











Standard housings		Split plummer block housings		
		SNV	SNS	S30
<ul style="list-style-type: none"> ● suitable ■ available design – not suitable/not applicable 				
detailed information ➤		1575	1624	1668
Bearing type				
Self-aligning ball bearings		●	–	–
Spherical roller bearings		●	●	●
Toroidal roller bearings		●	●	●
Barrel roller bearings		●	–	–
Cylindrical roller bearings		–	–	–
Deep groove ball bearings		●	–	–
Angular contact ball bearings		–	–	–
Spherical roller bearings, split		●	●	●
Mounting method				
On adapter sleeve		●	●	●
On withdrawal sleeve		–	–	–
On adjustment sleeve		–	–	–
On cylindrical seat		●	●	●
Lubrication				
Grease		●	●	●
Oil		●	●	–
Sealing				
Labyrinth seal, unsplit		■	■	–
Taconite seal, unsplit		■	■	–
Double lip seal, split		■	–	–
V ring seal, unsplit		■	–	–
Felt seal, split		■	–	■
Bolt-on seal, unsplit		–	■	–
Labyrinth seal, split		–	■	–
Taconite seal, split		–	■	–
High-pressure packing, split		–	–	–
Shaft diameter				
from	mm	20	115	110
	inch	3/4	47/16	–
to	mm	160	530	150
	inch	5 1/2	19 1/2	–
Product tables ➤ from page ➤		1598¹⁾	1650¹⁾	–²⁾

1) Housings for inch size shaft diameters ➤ GK 1

2) ➤ GK 1

3) ➤ TPI 229



					Unsplit plummer block housings		Take-up housings	Flanged housings	
SAF	RLE	KPG	KPGZ	LOE	VRE3	BND	SPA	F112	F5
									
1670	1673	1675	1675	1677	1679	1681	1684	1686	1687
-	-	-	-	-	-	-	-	●	●
●	●	●	●	●	-	●	●	-	●
-	●	-	-	-	-	●	-	-	-
-	-	-	-	-	-	-	-	-	●
-	-	-	-	-	●	-	-	-	-
-	-	-	-	-	●	-	-	-	-
-	-	-	-	-	●	-	-	-	-
●	-	●	●	-	-	-	-	-	-
●	-	-	-	●	-	●	●	-	●
-	●	-	-	-	-	-	-	-	-
-	-	●	-	-	-	-	-	-	-
-	●	-	●	●	●	●	-	●	-
●	●	●	●	-	●	●	●	●	●
●	-	-	-	●	-	-	-	-	-
■	■	-	-	■	-	■	■	-	-
■	-	-	-	-	-	■	■	-	-
-	-	-	-	-	-	-	-	-	-
-	-	-	-	-	■	-	-	-	-
-	-	-	-	-	■	-	-	■	■
-	-	-	-	-	-	-	-	-	-
■	-	-	-	-	-	-	-	-	-
■	-	-	-	-	-	-	-	-	-
-	-	■	■	-	-	-	-	-	-
-	180	470	500	50	25	60	50	20	20
1 ³ / ₈	-	-	-	-	-	-	-	-	-
-	500	1250	1320	240	120	420	400	60	100
8	-	-	-	-	-	-	-	-	-
- ₃₎	- ₂₎	- ₂₎	- ₂₎	- ₂₎	- ₂₎	- ₂₎	- ₂₎	- ₂₎	- ₂₎



1 Principles

1.1 Housing concepts

Standard housings

FAG standard housings are subdivided, in accordance with their fundamental design, into:

- split plummer block housings
- unsplit plummer block housings
- take-up housings
- flanged housings.

Split plummer block housings

In the case of split plummer block housings, the housing body is split into an upper section and a lower section. This gives significantly simpler mounting and maintenance. The two halves of a housing form a matched pair and must not be interchanged with parts from other housings.

Unsplit plummer block housings

In the case of unsplit plummer block housings, the housing body is a single piece, so the bearing seat is free from parting lines. The housings are used where the bearings are subjected to very high loads.

The unsplit plummer block housings also include plummer block housing units VRE3. These are made available as completely assembled and greased bearing arrangement units comprising a housing, seals, bearings and shaft.

Take-up housings

Take-up housings SPA were developed specifically for tensioner drum bearing arrangements in belt conveyor plant. The housings are unsplit. There is a yoke-shaped drawbar eye for attachment to the tensioning device.

Flanged housings

Flanged housings have a flange perpendicular to the shaft axis and thus offer the ideal adjacent construction for numerous machines and pieces of equipment where the use of plummer block housings would be too demanding.

Special requirements

Special housings

Special housings are used in particularly challenging applications where not all the requirements can be fulfilled by the use of standard housings. These are not only specific industrial applications but also applications from the railway sector.

Customer-specific development

Special housings are developed in close cooperation and consultation with the customer. Schaeffler uses its comprehensive know-how of rolling bearing technology in order to ensure that every housing is optimally matched to the specific application.

Further information on special housings is given in the Catalogue GK 1
► <https://www.schaeffler.de/std/1D54>.

1.2 Locating and non-locating bearing concepts

☞ *Different concepts depending on housing series*

In order to achieve locating bearing arrangements as well as non-locating bearing arrangements, one of the following concepts is applied in each housing series:

- housings in locating bearing design and non-locating bearing design
- housings with locating rings.

The unsplit plummer block housings VR3, where two bearing positions are integrated in one housing, constitute a special case here.

Complete plummer block housing units VRE3 can be ordered that, depending on their design, contain a locating/non-locating bearing arrangement, an adjusted bearing arrangement or a floating bearing arrangement.

Housings in locating bearing design and non-locating bearing design

In this housing concept for the implementation of a locating or non-locating bearing arrangement, the housing must be ordered as necessary in a locating bearing design or a non-locating bearing design. This applies to the housings RLE, KPG, KPGZ, LOE, BND and SPA.

☞ *Variation of covers*

In the case of the locating bearing design, the bearings are axially clamped between the covers on the housings ► 1571|☞ 1. In the case of the non-locating bearing design, the covers have shorter centring collars. As a result, the bearing can be axially displaced ► 1571|☞ 2.

☞ *The housing design is part of the designation*

When ordering, the designation indicates whether the housing should be supplied in a locating or non-locating bearing design.

☞ **1**

Housing in locating bearing design

- ① Centring collars on covers for axial location of the bearing

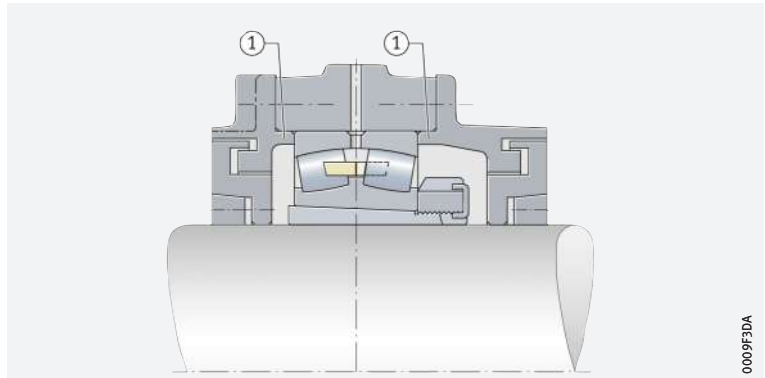

☞ **2**

Housing in non-locating bearing design

- ① Bearing can be axially displaced

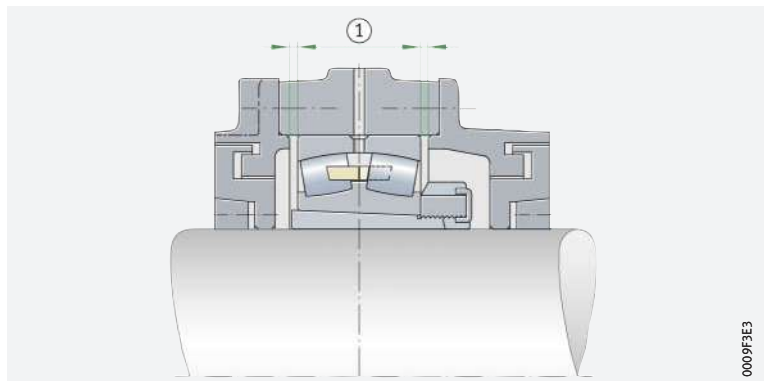

Housings with locating rings

In this housing concept for the implementation of a locating or non-locating bearing arrangement, locating rings are available as accessories that can be used to set the locating bearing function ▶ 1572 | 3. This applies to the housings SNV, SNS, S30, SAF and F5.

☞ *Variation of the number of locating rings*

In the case of these housings, the bearing seats are designed such that the bearing is capable of axial displacement and therefore acts as a non-locating bearing if locating rings are not inserted ▶ 1572 | 4. Once locating rings are inserted, the bearings are axially located. The locating rings are generally inserted in the housing on both sides of the bearing. Normally, an even number of locating rings is specified in order to achieve concentric seating of the bearing in the housing. In some cases, a single locating ring is sufficient.

☞ *Locating rings must be ordered separately*

The number of locating rings required is given in the product tables. Locating rings must be ordered separately.

3
 Locating bearing arrangement, as a result of inserted locating rings

① Locating rings give axial location of the bearing

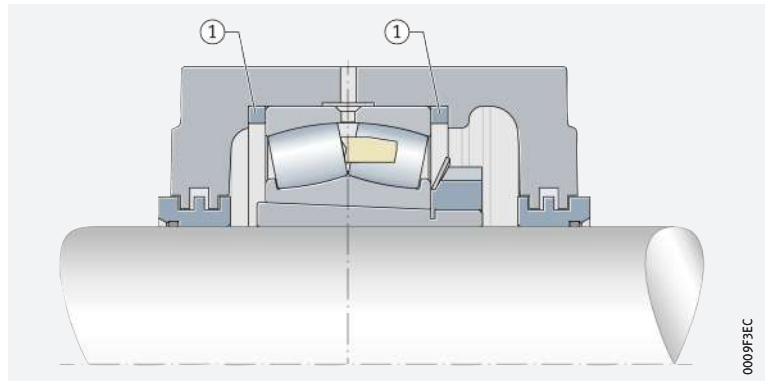

4
 Non-locating bearing arrangement, no locating rings inserted

① Bearing can be axially displaced

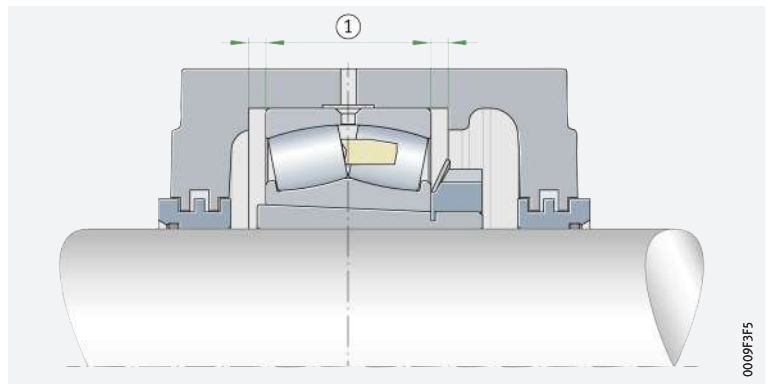

1.3 Materials

☞ *Standard materials*

Depending on the housing series, the standard material used for FAG standard housings is flake graphite cast iron, spheroidal graphite cast iron or cast steel. The material is generally indicated by a suffix in the housing designation. This indication is omitted in the case of some housings where these are only available in one material variant.

Suffixes:

- L for flake graphite cast iron
- D for spheroidal graphite cast iron
- S for cast steel.

☞ *Other materials available by agreement*

By agreement, housings made from other materials are also available. The material should be selected on the basis of a careful analysis of the application and the associated requirements.

Flake graphite cast iron

☞ *Restricted tensile strength and ductility, good compressive strength*

For standard housings made from flake graphite cast iron, cast iron in accordance with DIN EN 1561 is generally used. In these cast materials with an iron/carbon/silicon base, the graphite inclusions are present in lamellar form. Under tensile load, these act as internal notches. The tensile strength of flake graphite cast iron is therefore limited and its ductility is comparatively low. The compressive strength of this alloy is, however, higher than the tensile strength by a factor of 4. These alloys also have good inherent stability.

☞ *Economical material for simple requirements*

Flake graphite cast iron is therefore used in the case of housings with simple requirements. Furthermore, flake graphite cast iron represents the most economical variant of the cast materials available for use in housings.

In the case of split plummer block housings SAF, flake graphite cast iron to ASTM A48 Class35 is used.

Spheroidal graphite cast iron

☞ *Higher tensile strength and ductility than flake graphite cast iron*

For standard housings made from spheroidal graphite cast iron, cast iron in accordance with DIN EN 1563 is generally used. Due to an addition of magnesium or, more rarely cerium or calcium, the graphite inclusions adopt a spheroidal form during casting. As a result, the tensile strength and ductility are higher than those of the grades with a lamellar graphite form.

☞ *Material for increased requirements*

Spheroidal graphite cast iron is therefore used in the case of housings with an increased profile of requirements. The costs of spheroidal graphite cast iron are between those for flake graphite cast iron and cast steel.

In the case of split plummer block housings SAF, spheroidal graphite cast iron to ASTM A536 Grade 65-45-12 is used.

Cast steel

☞ *Moderate to high strength with high elongation at fracture*

For standard housings made from cast steel, steel in accordance with DIN EN 10293 is generally used. Both unalloyed and alloyed steels are suitable for casting. The unalloyed cast steel used for housings combines moderate to high strength values with high elongation at fracture.

☞ *Material for high requirements*

Cast steel is therefore used in the case of housings with high requirements for mechanical properties as well as a requirement for high ductility. The costs of cast steel are higher than the costs for flake graphite cast iron or spheroidal graphite cast iron. It is therefore recommended that checks be carried out to establish whether the material is really necessary in relation to the requirements of the specific application.



1.4 Corrosion protection

- ☞ *Universal paint coating* All outer surfaces of standard housings not machined by chip-forming methods and the locating surfaces on the lower housing section have a universal paint coating. The coating can be finished using all synthetic resin, polyurethane, acrylic, epoxy resin, chlorinated rubber, nitrocellulose and acid-hardening hammer tone finishes.
- ☞ *Corrosion protection* Inner and outer surfaces machined by chip-forming methods are provided with corrosion protection that can be easily removed. It is recommended that only volatile solvents and lint-free cloths should be used.
- ☞ *Special solutions available by agreement* If there are particular requirements relating to paint coating and corrosion protection, special solutions are possible. If particular specifications are presented by the customer, we check their feasibility and these can be implemented if the result is positive.

1.5 Selection wizard for bearing housings

medias professional, the electronic product selection and advisory system from Schaeffler, includes a selection wizard for bearing housings ► <https://www.schaeffler.de/std/1D61>. This gives comprehensive assistance in the selection of housings and housing units. It takes account of the environmental conditions and the requirements placed on the bearing arrangement as well as the characteristics of the housings and the bearings suitable for the housings. Once the specified data have been inputted, the software generates detailed lists of results that also contain information on further accessories.

2 Split plummer block housings SNV



Split plummer block housings SNV:

- are designed in accordance with a modular concept and are highly versatile in application ▶ 1575|2.1
- are suitable for different bearing types and sizes with bore diameters from 20 mm to 160 mm ▶ 1576|2.2
- can be combined with an extensive range of seals covering a wide range of requirements and temperatures ▶ 1575|1 and ▶ 1586|2.7.

 1
 Seals for split plummer block housings SNV

T = permissible long term temperature of seal

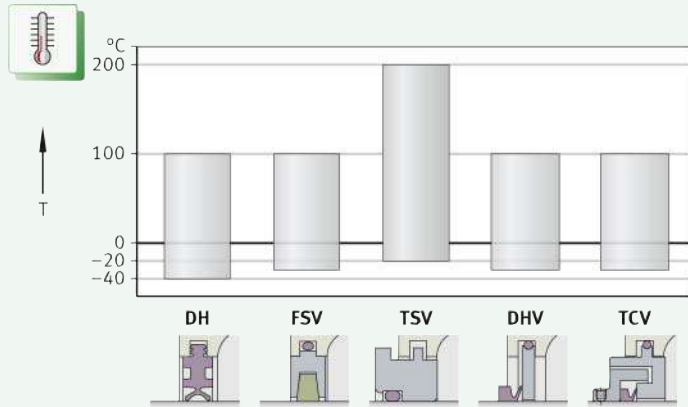

2.1 Housing design

 *Housings for wide range of applications*

Split plummer block housings SNV and the associated bearings form bearing arrangement units that can be matched, through the appropriate selection of accessories, to a wide range of applications ▶ 1576|2. Applications include agricultural machinery, the paper processing industry, mining, materials processing, the steel industry and power stations.





Split plummer block housing SNV

Housings SNV052 to SNV200 are supplied without an eye bolt, housings SNV215 to SNV340 are supplied with an eye bolt.



Modular concept

- The decisive factor is the outside diameter of the bearing
- Seals are matched to the shaft diameter

The housings are designed in accordance with a modular concept. Each housing can be fitted with rolling bearings of various diameter and width series if they have the correct outside diameter for the housing. Depending on their design, the bearings can be located either directly on the shaft or by means of an adapter sleeve. This gives different shaft diameters for the same bearing size. The spacings between the shaft and housing body are compensated by means of appropriately matched seals.

2.2

Suitable bearings

Shaft diameters from 20 mm to 160 mm and from 3/4 inch to 5 1/2 inch

Split plummer block housings SNV are intended for fitting with spherical roller bearings, toroidal roller bearings, self-aligning ball bearings and barrel roller bearings with a tapered or cylindrical bore as well as deep groove ball bearings 1576 1. The range of shaft diameters is 20 mm to 160 mm and 3/4 inch to 5 1/2 inch.

1 Bearing types and sizes

Bearing type	Size
Spherical roller bearings with tapered bore and adapter sleeve	21307..-K to 21322..-K
	22205..-K to 22232..-K
	22308..-K to 22332..-K
	23218..-K to 23232..-K
with cylindrical bore	21304 to 21322
	22205 to 22232
	22308 to 22332
	23218 to 23232
Toroidal roller bearings with tapered bore and adapter sleeve	C2212..-K to C2232..-K
	C2312..-K to C2332..-K
	C3218..-K to C3232..-K
with cylindrical bore	C2212 to C2232
	C2312 to C2332
	C3218 to C3232

continued

1 Bearing types and sizes

Bearing type	Size
Self-aligning ball bearings ■ with tapered bore and adapter sleeve	1205-K to 1222-K
	1305-K to 1320-K
	2205-K to 2220-K
	2305-K to 2320-K
■ with cylindrical bore	1205 to 1222
	1305 to 1320
	2205 to 2220
	2304 to 2320
Barrel roller bearings ■ with tapered bore and adapter sleeve	20205-K to 20232-K
	20305-K to 20332-K
■ with cylindrical bore	20205 to 20232
	20305 to 20330
Deep groove ball bearings ■ with cylindrical bore	6205 to 6232
	6304 to 6332

continued ▲

Split spherical roller bearings



Unsplit spherical roller bearings with an adapter sleeve can be replaced by split spherical roller bearings. This gives a considerable reduction in the work associated with bearing replacement in numerous applications. In order to ensure selection of the correct combination of housing and bearing when using split bearings, please contact Schaeffler.



The range of split spherical roller bearings is described in detail in a separate publication ► [TPI 250](#).

2.3

Materials, corrosion protection

Materials

The standard material for the housing bodies is flake graphite cast iron EN-GJL-HB215 in accordance with DIN EN 1561 (suffix L). By agreement, housing bodies made from spheroidal graphite cast iron EN-GJS-400-15 in accordance with DIN EN 1563 (suffix D) are available.

Corrosion protection

All outer surfaces not machined by chip-forming methods have a universal paint coating (colour RAL 7031, blue grey). The coating can be finished using all synthetic resin, polyurethane, acrylic, epoxy resin, chlorinated rubber, nitrocellulose and acid-hardening hammer tone finishes.

Inner and outer surfaces machined by chip-forming methods are provided with anti-corrosion protection that can be easily removed.

It is recommended that only volatile solvents and lint-free cloths should be used.

2.4

Locating and non-locating bearings

Locating bearing arrangement by means of locating rings

The bearing seats in the housing are machined such that the bearings are movable in the housing and can thus function as non-locating bearings. Locating bearing arrangements can be achieved by the insertion of one locating ring FRM on each side of the bearing outer ring. The bearing is thus seated in the centre of the housing. Locating rings must be ordered separately.



2.5 Load carrying capacity

🔑 Guide values

Guide values are given for the rupture load of plummer block housings SNV and the maximum load carrying capacity of connecting screws for the upper and lower housing sections ▶ 1578|🔑 3 and ▶ 1579|🔑 2. The guide values are valid for purely static loading. The guide values for housing rupture load are valid for the standard housing material flake graphite cast iron (suffix L). For spherical graphite cast iron (suffix D) a factor of 1,6 should be applied.

The guide values only apply if the flatness of the mounting surface in accordance with DIN EN ISO 1101 corresponds to the tolerance grade IT8 in accordance with DIN EN ISO 286-1 (measured across the diagonal). A precondition for supporting loads is that the housing base surface is completely and rigidly supported.

🔑 Safety factors

When determining the permissible static load, safety factors must be applied:

- safety factor of 6 relative to the housing rupture load
- safety factor of 3 relative to the maximum load carrying capacity of the connecting screws.



The housing must not be subjected to an axial load of more than $\frac{2}{3}$ of the housing rupture load F_{180° .

If the housing is subjected to axial load, the permissible axial load of the bearing fitted must be taken into consideration. If the bearing is located on the shaft using an adapter sleeve, the axial retaining force of the bearing and adapter sleeve must also be taken into consideration.

If the load direction is between 55° and 120° or axial load is present, we recommend that the housings should be secured in the load direction by means of stops or dowels.

🔑 3
Load directions F
for the guide values
for the housing rupture load and
the maximum load carrying
capacity of the connecting screws

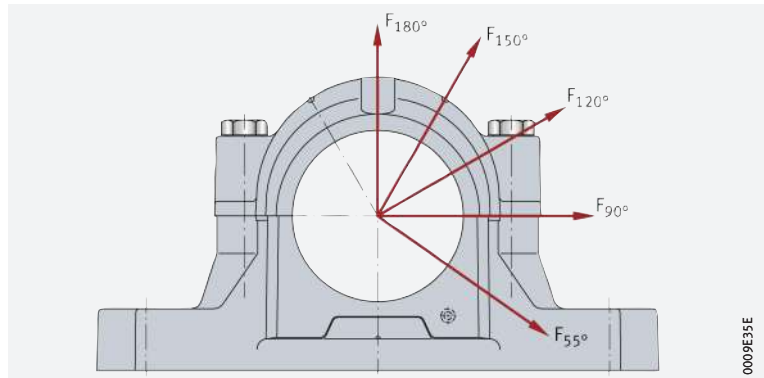

2 Guide values for housing rupture load and maximum load carrying capacity of connecting screws. Tightening torques

Housing	Housing rupture load in load direction F Housing made from flake graphite cast iron					Connecting screws				
	55° kN	90° kN	120° kN	150° kN	180° kN	Thread to DIN 13 Grade 8.8	Tightening torque ¹⁾ Nm	Maximum load carrying capacity in load direction F ²⁾		
								120° kN	150° kN	180° kN
SNV052-F-L	160	95	70	60	80	M10	51	60	35	30
SNV062-F-L	170	100	80	65	85	M10	51	60	35	30
SNV072-F-L	190	110	85	80	95	M10	51	60	35	30
SNV080-F-L	210	130	95	85	105	M10	51	60	35	30
SNV085-F-L	225	140	100	90	120	M10	51	60	35	30
SNV090-F-L	265	160	120	105	130	M10	51	60	35	30
SNV100-F-L	280	170	125	120	140	M12	87	80	45	40
SNV110-F-L	300	180	130	125	150	M12	87	80	45	40
SNV120-F-L	335	200	150	130	170	M12	87	80	45	40
SNV125-F-L	335	200	150	130	170	M12	87	80	45	40
SNV130-F-L	400	250	180	150	200	M12	87	80	45	40
SNV140-F-L	425	265	190	170	210	M12	87	80	45	40
SNV150-F-L	475	280	200	180	235	M12	87	80	45	40
SNV160-F-L	530	335	250	210	265	M16	215	180	100	90
SNV170-F-L	560	355	265	225	280	M16	215	180	100	90
SNV180-F-L	630	375	280	250	300	M20	430	260	150	130
SNV190-F-L	630	375	280	250	300	M20	430	260	150	130
SNV200-F-L	670	400	315	280	335	M20	430	260	150	130
SNV215-F-L	800	450	355	315	400	M20	430	260	150	130
SNV230-F-L	900	530	400	355	450	M24	740	360	210	180
SNV240-F-L	1 000	600	450	400	500	M24	740	360	210	180
SNV250-F-L	1 060	630	475	425	530	M24	740	360	210	180
SNV260-F-L	1 180	710	530	475	600	M24	740	360	210	180
SNV270-F-L	1 180	710	530	475	600	M24	740	360	210	180
SNV280-F-L	1 320	750	600	530	630	M24	740	360	210	180
SNV290-F-L	1 400	850	630	560	710	M24	740	360	210	180
SNV300-F-L	1 500	900	670	600	750	M24	740	360	210	180
SNV320-F-L	1 700	1 000	750	670	850	M24	740	360	210	180
SNV340-F-L	1 900	1 120	850	750	950	M30	1 450	640	370	320

Housings made from spheroidal graphite cast iron (suffix D) have a housing rupture load that is 1,6 times higher than that of housings made from flake graphite cast iron.

¹⁾ The tightening torques are maximum values when utilising 90% of the yield stress of the screw material and with a friction factor of 0,14. We recommend that the screws should be inserted to 70% of these values.

²⁾ Maximum load carrying capacity in load direction F, where there is still contact at the parting line between the upper and lower housing sections.



2.6 Lubrication

Grease lubrication

Split plummer block housings SNV are principally intended for grease lubrication. The housings can, however, also be supplied in a design for oil lubrication.

Lubricating greases

Suitable greases

Arcanol MULTITOR, a lithium soap grease of NLGI class 2 with particularly effective EP additives, is highly suitable under the following conditions:

- bearing operating temperatures $< +100\text{ °C}$
- bearing loads $P/C < 0,3$
- bearing-specific speed parameter $k_f \cdot n \cdot d_M < 700\,000\text{ min}^{-1} \cdot \text{mm}$
where: $k_f = 1$ for self-aligning ball bearings and deep groove ball bearings, $k_f = 8$ to $10,5$ for spherical roller bearings.

Due to their favourable flow behaviour, greases of NLGI grade 2, such as Arcanol MULTITOR and Arcanol MULTI2, are more suitable for relubrication than greases of higher consistency grades.

Grease quantities

Basic rule for initial greasing

For initial greasing, the basic rule is that the bearing should be filled with grease to 100% and the free volume of the housing to 60%. This is the basis for the recommended grease quantities $\blacktriangleright 1580$  3. The free volume is the space that remains in the housing once the bearing, adapter sleeve, shaft and seals have been fitted.

Relubrication

For relubrication, minimum quantities of grease are recommended $\blacktriangleright 1580$  3.

 3
Recommended grease quantities for initial greasing and relubrication

Housing	Grease quantity	
	Initial greasing \approx g	Relubrication (minimum quantity) \approx g
SNV052-F	30	5
SNV062-F	45	5
SNV072-F	65	10
SNV080-F	80	10
SNV085-F	105	10
SNV090-F	130	10
SNV100-F	180	15
SNV110-F	210	15
SNV120-F	270	20
SNV125-F	290	20
SNV130-F	330	20
SNV140-F	440	25
SNV150-F	500	30
SNV160-F	650	40
SNV170-F	700	45
SNV180-F	900	55
SNV190-F	950	60
SNV200-F	1 200	70
SNV215-F	1 400	80
SNV230-F	1 600	85
SNV240-F	1 700	90
SNV250-F	2 000	100
SNV260-F	2 000	120
SNV270-F	2 500	130

continued 



*Recommended grease quantities
for initial greasing and
relubrication*

Housing	Grease quantity	
	Initial greasing	Relubrication (minimum quantity)
	≈ g	≈ g
SNV280-F	2 600	140
SNV290-F	3 000	150
SNV300-F	3 100	160
SNV320-F	3 700	200
SNV340-F	4 500	240

continued ▲

*Special case
with 100% grease filling*

With a speed parameter $n \cdot d_M < 50\,000 \text{ min}^{-1} \cdot \text{mm}$ and a non-contact seal (labyrinth seal TSV), where the grease should also perform a sealing function, the housing and seal cavities should be filled to 100%.

*Bearings
with circumferential
lubrication groove*

Relubrication

Where relubrication is carried out on bearings with a circumferential lubrication groove, the grease is introduced into the housing via the central lubrication hole ►1582|☞4. In this type of relubrication, the grease acts directly on the bearing raceway.

*Bearings
without lubrication groove*

Where relubrication is carried out on bearings without a lubrication groove, the grease must be introduced into the housing via the lateral lubrication hole. In this case, the housing cavities on the side with the lubrication nipple must be filled completely with grease so that the relubrication grease can act immediately on the bearing.

*Permanent use
of lubrication nipples*

In both cases, the lubrication hole present (threaded hole M10×1) is prepared by removing the screw plug and permanently inserting one of the lubrication nipples supplied at this point.

*Marked positions
for further lubrication holes*

As an alternative to the lubrication holes already present, lubrication holes may be introduced at other positions as indicated by the cast-in marking points.

Lubrication holes can be introduced at further marked positions for the relubrication of labyrinth seals.

Prevention of overgreasing

For relubrication, minimum quantities of grease are recommended ►1580|☞3. In order to prevent overgreasing, the screw plug in the grease outlet hole in the lower housing section must be removed while relubrication is being carried out. This allows superfluous grease to escape. This must be observed in particular when using double lip seals DH. Otherwise, there is a risk that the double lip seal will be pressed out of the housing.



The grease outlet hole must then be closed off again using the screw plug. If unfavourable environmental conditions are present, there is therefore a risk of contaminant ingress into the housing when the grease outlet holes are opened.



4

Positions for relubrication

- ① SNV052-F to SNV200-F
- ② SNV215-F to SNV340-F
- ③ Central lubrication hole, for bearings with lubrication groove
- ④ Lateral lubrication hole, for bearings without lubrication groove
- ⑤ Marked positions for further lubrication holes for lubrication of the bearing
- ⑥ Marked positions for lubrication holes for lubrication of seals
- ⑦ Grease outlet hole

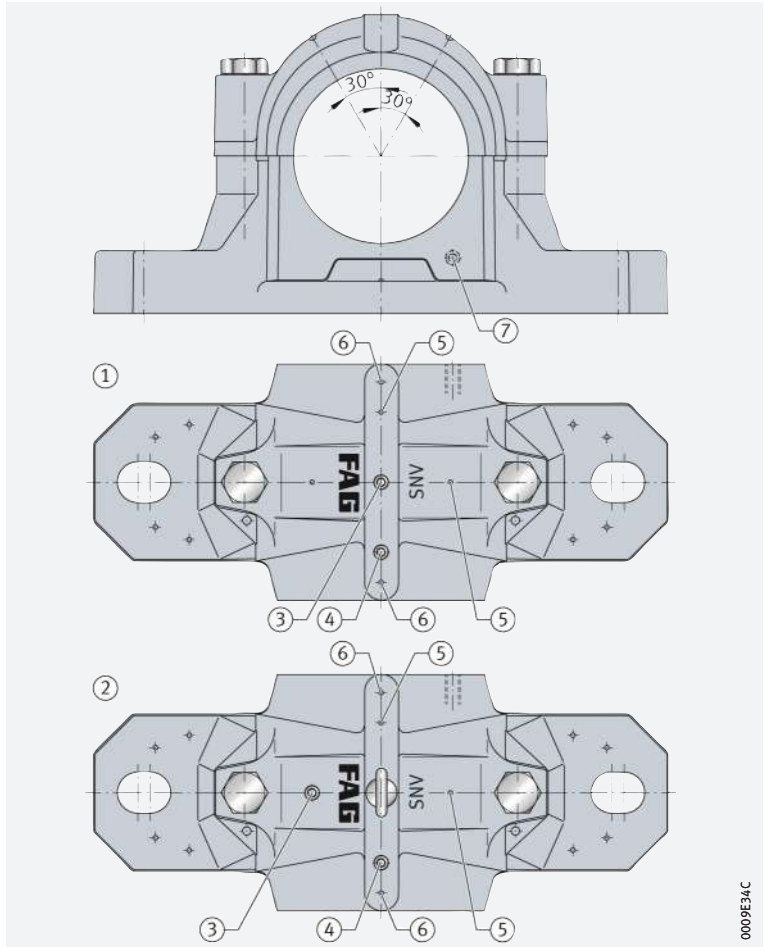

0009E3AC

Standard parts and dimensions

Screw plugs

The lubrication and grease outlet holes are closed off using screw plugs to DIN 906.

Lubrication nipples

Lubrication nipples with a dust cap are supplied as followed:

- button head lubrication nipples to DIN 3404-M10×1
- taper type lubrication nipple to DIN 71412-AM10×1.

Dimensions

The size of the grease outlet hole is dependent on the size of the housing
 ► 1582 | 4.

4

Dimensions of threaded holes

Housing	Thread for	
	Grease outlet hole	Relubrication hole
SNV052-F – SNV090-F	M10×1	M10×1
SNV100-F – SNV125-F	M14×1,5	
SNV130-F – SNV340-F	M20×1,5	

Suitability for oil bath and recirculating oil lubrication

Oil lubrication

Split plummer block housings SNV are suitable not only for grease lubrication but also for oil bath lubrication and recirculating oil lubrication. The housings have a large internal cavity with oil collector pockets in the lower section. Due to the housing geometry, it is possible to introduce connection holes for oil inlet, oil outlet, an oil sight glass and a temperature sensor.

Dimensions

Connection holes for oil lubrication

The recommended dimensions are valid for oil bath lubrication and for recirculating oil lubrication ▶ 1583| 5, ▶ 1584| 6 and ▶ 1584| 5.

Utilisation

If recirculating oil lubrication is used, the hole M₂ is intended for the oil inlet function. If oil bath lubrication is used, a venting device can be installed for venting of the housing.

If oil bath lubrication is used, the hole M₄ is intended for the oil sight glass. If recirculating oil lubrication is used, the hole can be used for the oil outlet.

5
Recommended dimensions of connection holes for oil inlet and oil outlet

Housing	Connection for				
	Oil inlet		Oil outlet		
	M ₂	n _{3/2} mm	M ₃	α °	g ₆ mm
SNV100-F	G ¹ / ₄	31	M10×1	50	44
SNV110-F	G ¹ / ₄	33,5	M10×1	50	46
SNV120-F	G ¹ / ₄	35,5	M10×1	50	49
SNV125-F	G ¹ / ₄	28,5	M10×1	50	49
SNV130-F	G ¹ / ₄	38	M10×1	50	51,5
SNV140-F	G ¹ / ₄	40,5	M10×1	60	57,5
SNV150-F	G ¹ / ₄	42,5	M10×1	60	60
SNV160-F	G ¹ / ₄	45	M10×1	60	62,5
SNV170-F	G ¹ / ₄	46,5	M10×1	60	64
SNV180-F	G ¹ / ₄	19,5	M10×1	60	69
SNV190-F	G ¹ / ₄	49,5	M10×1	60	68,5
SNV200-F	G ¹ / ₄	55,5	M10×1	60	77,5
SNV215-F	G ¹ / ₄	58,5	M10×1	60	80
SNV230-F	G ¹ / ₄	61	M10×1	60	83
SNV240-F	G ¹ / ₄	60	M10×1	60	81,5
SNV250-F	G ¹ / ₄	65,5	M10×1	60	89
SNV260-F	G ¹ / ₄	62,5	M10×1	60	84
SNV270-F	G ¹ / ₄	71,5	M10×1	60	86,5
SNV280-F	G ¹ / ₄	68	M10×1	60	92,5
SNV290-F	G ¹ / ₄	76	M10×1	60	102,5
SNV300-F	G ¹ / ₄	73	M10×1	60	99,5
SNV320-F	G ¹ / ₄	77	M10×1	60	105,5
SNV340-F	G ¹ / ₄	81	M10×1	60	109,5



6
*Recommended dimensions
of connection holes
for oil sight glass*

Housing	Connection for oil sight glass			
	M ₄	g ₇ mm	h ₃	D ₅
SNV100-F	G ³ / ₈	33	31	24
SNV110-F	G ³ / ₈	35	28	24
SNV120-F	G ³ / ₈	38	35	24
SNV125-F	G ³ / ₈	44	24	24
SNV130-F	G ¹ / ₂	43	28,5	30
SNV140-F	G ¹ / ₂	45	40	30
SNV150-F	G ¹ / ₂	47	38	30
SNV160-F	G ¹ / ₂	50	39	30
SNV170-F	G ³ / ₄	55	46	36
SNV180-F	G ³ / ₄	57	43	36
SNV190-F	G ³ / ₄	48	45	36
SNV200-F	G ³ / ₄	62	50	36
SNV215-F	G ³ / ₄	67	58	36
SNV230-F	G ³ / ₄	70	60	36
SNV240-F	G ³ / ₄	61	60	36
SNV250-F	G ³ / ₄	75	55	36
SNV260-F	G ³ / ₄	65	65	36
SNV270-F	G ³ / ₄	81	55	36
SNV280-F	G ³ / ₄	70	60	36
SNV290-F	G ³ / ₄	87	58	36
SNV300-F	G ³ / ₄	75	70	36
SNV320-F	G ³ / ₄	80	73	36
SNV340-F	G ³ / ₄	95	75	36

5
Dimensions of connection holes



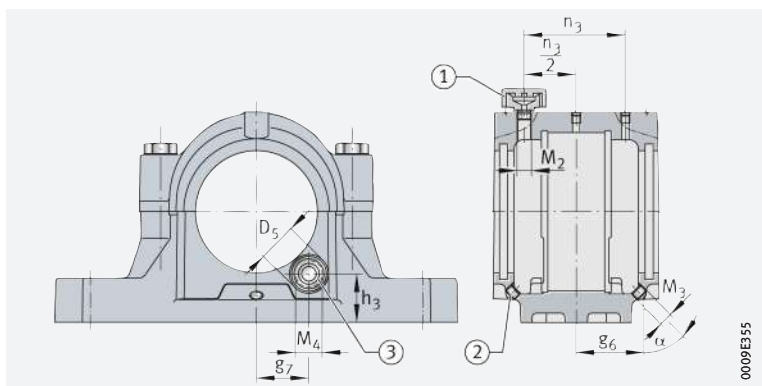



- ① Venting device
- ② Screw plug
- ③ Oil sight glass



0009E355

Housings with connection holes for oil lubrication

Design for oil lubrication

Plummer block housings SNV can be supplied by agreement in a design for oil lubrication. Housings of this design already have the connection holes for oil inlet, oil outlet and an oil sight glass to the recommended dimensions  1583 |  5,  1584 |  6 and  1584 |  5.

The scope of delivery of the design for oil lubrication includes:

- 1 oil sight glass OSGL
- 1 venting device VENT
- 2 screw plugs VSB.

Housings with connection holes according to individual customer specifications can also be supplied once their feasibility has been checked.

Sealing

Sealing of the shaft

When using the double lip seal DH, a certain amount of oil leakage must be expected, which is unavoidable with seals that are split and not spring-loaded.

In order to limit oil leakage to a small quantity, the shaft in the seal area should have the following characteristics:

- hardness at least 55 HRC
- ground without spiral marks to $R_a = 0,2 \text{ mm}$, but at least $R_a \leq 0,5 \text{ }\mu\text{m}$.





A technically oiltight design is only possible with a spring-loaded, unsplit rotary shaft seal.

Sealing of the housing body

The parting line between the upper and lower housing sections must be sealed with a thin layer of a commercial sealant (with permanent elasticity). In the case of a housing closed on one side, the base of the groove in which the cover is inserted must be brushed with sealant.

Guidelines for oil bath lubrication

Minimum oil level

When using oil bath lubrication, a minimum oil level must be ensured. This corresponds to the dimension h_3  1584 |  6 and  1584 |  5.

Housing venting

When using oil bath lubrication, venting of the housing is absolutely necessary.



For operation with oil bath lubrication, venting of the housing must be provided. For example, the filling hole can be closed off using a bleed screw.



2.7 Sealing

Seals

🔑 *Standard seals* For the sealing of the bearing housings, the standard seals available are the double lip seal, the felt seal, the labyrinth seal, the V ring seal and the taconite seal. These seals are matched to the rectangular section annular slots on both sides of the housings. They are principally suitable for grease lubrication. The seals must be ordered separately. In the case of the double lip seal and felt seal, the scope of delivery comprises two seals, while all other seals are supplied individually. If a continuous shaft is present, two seals must be ordered.

🔑 *Special seals* Special seals are also available by agreement.

Double lip seal DH

🔑 *Separate sealing functions inwards and outwards*

The seal lips of the double lip seal DH slide on the rotating shaft. The outer seal lip prevents ingress of contamination into the bearing. This effect is supported by the grease inserted between the seal lips. The inner seal lip prevents lubricant from escaping from the housing. The seal is made from acrylonitrile butadiene rubber NBR and is suitable for circumferential velocities of up to 13 m/s. For continuous operation, a maximum circumferential velocity of 6 m/s is recommended.

The seal is suitable for temperatures from -40 °C to $+100\text{ °C}$. It allows shaft misalignment of up to $0,5^\circ$ in both directions.

🔑 *Two-piece seal for simplified fitting*

The double lip seal DH is a two-piece seal. It can be easily inserted in the annular slots in the housing. The parting joint of the seal halves should be in the same plane as the parting joint of the housing.

🔑 *Shaft*

The contact running area on the shaft for the seal lips should have a roughness Ra 3,2.

Felt seals FSV

🔑 *Robust seal for grease lubrication*

Felt seals FSV are particularly suitable for grease lubrication. They comprise an adapter holding the inserted, oil-impregnated felt strip and the adapter is secured against rotation by an O ring in the annular slot in the housing. The seals are suitable for circumferential velocities of up to 5 m/s and, after running-in, of up to 15 m/s. They can be used at temperatures up to $+100\text{ °C}$. The permissible shaft misalignment is $0,5^\circ$ in both directions.

🔑 *Aramide packing*

By agreement, aramide packing is available for temperatures of more than 100 °C .

Labyrinth seals TSV

🔑 *Non-contact seal for high circumferential velocities*

Labyrinth seals TSV give non-contact sealing. They are therefore suitable for high circumferential velocities. The O ring, which is pressed between the labyrinth ring and shaft, is made from fluoro rubber FKM and is suitable for temperatures of up to $+200\text{ °C}$. The labyrinth seal allows shaft misalignment of up to $0,5^\circ$ in both directions.

🔑 *Relubrication*

If necessary, the labyrinth can be relubricated. For this purpose, a lubrication hole must be made in the upper housing section for each labyrinth seal. The optimum positions are indicated by cast-in pilot holes.

V ring seals DHV

🔑 *Seal in axial contact*

In the case of V ring seals DHV, the seal lip is in axial contact with the sliding surface which is located in the rectangular section annular slot of the housing. The seal is made from NBR and is suitable, when using grease lubrication, for circumferential velocities of up to 12 m/s. If circumferential velocities of more than 8 m/s are present, axial location is necessary. The seal allows shaft misalignment of up to $0,5^\circ$ in both directions.

Taconite seals TCV

🔑 *Seal for extreme contamination impact*

Taconite seals TCV are combined seals comprising a labyrinth seal and a V ring. These seals are suitable for extreme operating conditions in relation to contamination and dust. The V ring is made from NBR and is suitable for temperatures of up to $+100\text{ °C}$. The taconite seal allows shaft misalignment of up to $0,5^\circ$ in both directions.

Covers

Covers are used in the case of housings closed on one side. The covers fit in the rectangular section annular slots in the housings.

Covers DKV

Covers made from plastic

Covers DKV are made from plastic and are suitable for long term temperatures of up to +120 °C. The covers must be ordered separately.

Covers DKVT

Covers made from metal

Covers DKVT are made from steel, flake graphite cast iron or spheroidal graphite cast iron and are suitable for temperatures of up to +200 °C. Covers are available by agreement.

Characteristics and operating limits

The characteristics and operating limits of the standard seals and covers are compared in an overview ► 1588 |  7.





Standard seals and covers for plummer block housings SNV

++ = highly suitable

+ = suitable

(+) = suitable with restrictions

- = not suitable

Seals and covers	Double lip seal, split		Felt seal, split	
Designation	DH		FSV	
Material	NBR		Steel, felt, NBR	
Pieces per pack	2		2	
Suitability for sealing against				
dust	++		+	
fine, solid particles	++		-	
coarse, solid particles	+		-	
slivers	+		+	
spray liquids	+		-	
Operating limits				
Long term temperature	°C	-40 to +100 (due to NBR)	-30 to +100 (due to NBR)	
	°F	-40 to +210 (due to NBR)	-22 to +210 (due to NBR)	
Circumferential velocity	m/s	≤13 (continuous 6)	5 (after running-in 15)	
Misalignment	°	≤0,5	≤0,5	
Low friction		++	-	
Axial shaft displacement (suitability as non-locating bearing)		++	++	
Vertical arrangement		+	-	
Suitability for grease relubrication		++	-	
Suitability for oil lubrication		(+)	-	
Compatibility with sunlight		+	++	
Preconditions				
Tolerance class ¹⁾ of shaft diameter		h8 (h9)	h8 (h9)	
Shaft roughness	μm	Ra 3,2	Ra 3,2	

¹⁾ The envelope requirement © applies

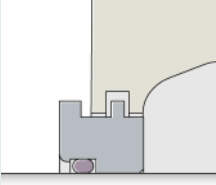
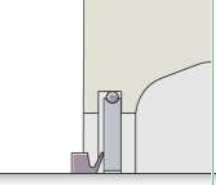
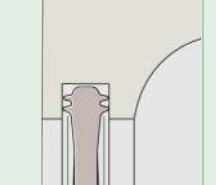
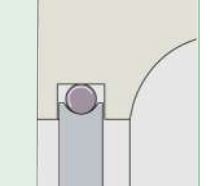
Labyrinth seal, unsplit	V ring seal, unsplit	Taconite seal, unsplit	Covers	
				
TSV	DHV	TCV	DKV	DKVT
Steel, FKM	Steel, NBR	Steel, NBR	Plastic	Steel or cast iron, FKM
1	1	1	1	1
+	+	++	+	+
+	+	++	+	+
+	-	++	+	+
++	-	++	+	+
-	+	++	+	+
-20 to +200 (due to FKM)	-30 to +100 (due to NBR)	-30 to +100 (due to NBR)	-40 to +120	-20 to +200 (due to FKM)
-4 to +390 (due to FKM)	-22 to +210 (due to NBR)	-22 to +210 (due to NBR)	-40 to +250	-4 to +390 (due to FKM)
No restriction	≤12	≤12	Not applicable	Not applicable
≤0,5	≤0,5	≤0,5	Not applicable	Not applicable
++	++	+	Not applicable	Not applicable
+	(+)	+	Not applicable	Not applicable
-	(+)	-	+	+
+	(+)	+	+	++
-	-	-	-	++
++	-	++	(+)	++
h8 (h9)	h8 (h9)	h8 (h9)	Not applicable	Not applicable
Ra 3,2	Ra 3,2	Ra 3,2	Not applicable	Not applicable



2.8 Dimensions, tolerances

Dimensions



The dimensions of housings SNV correspond to ISO 113 and DIN 736 to DIN 739.

Interchangeability

The housings SNV are interchangeable with the existing housings SN and SNE.

Tolerances for the bearing seat



The bearing seat in split plummer block housings SNV is machined to the tolerance class G7 in accordance with DIN EN ISO 286-1.

The tolerance indicated is valid in the delivered condition, i.e. before the screws connecting the upper and lower sections are loosened.

By agreement, the housings can also be supplied with other tolerance classes for the bearing seat.

2.9 Housing configurations

Modular construction allows numerous combinations

Possible combinations

On the basis of the standard components, the following features can be varied in the housing configuration ►1591| 6 and ►1591| 7:

- location of bearings with a tapered bore by means of an adapter sleeve on a shaft of constant diameter or of bearings with a cylindrical bore directly on a stepped shaft
- sealing of housing by double lip seal, felt seal, labyrinth seal, V ring seal or taconite seal
- continuous shaft or a housing closed on one side
- cover made from plastic (DKV) or cover made from steel or cast iron (DKVT)
- design of the bearing arrangement as a locating bearing arrangement or a non-locating bearing arrangement
- spherical roller bearing of split or unsplit design.

6

Plummer block housing SNV
for bearings with tapered bore and
adapter sleeve
(overview of combinations)

- ① Locating bearing
- ② Non-locating bearing
- ③ Labyrinth seal TSV
- ④ Cover DKV
- ⑤ Cover DKVT
- ⑥ Taconite seal TCV
- ⑦ Double lip seal DH
- ⑧ V ring seal DHV
- ⑨ Felt seal FSV

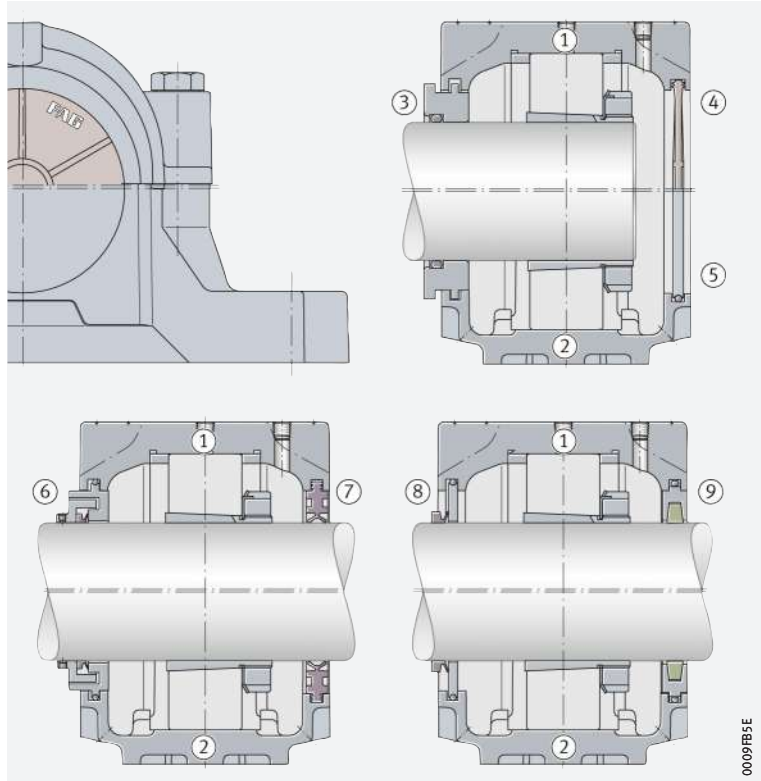

7

Plummer block housing SNV
for bearings with cylindrical bore
(overview of combinations)

- ① Locating bearing
- ② Non-locating bearing
- ③ Labyrinth seal TSV
- ④ Cover DKV
- ⑤ Cover DKVT
- ⑥ Taconite seal TCV
- ⑦ Double lip seal DH
- ⑧ V ring seal DHV
- ⑨ Felt seal FSV

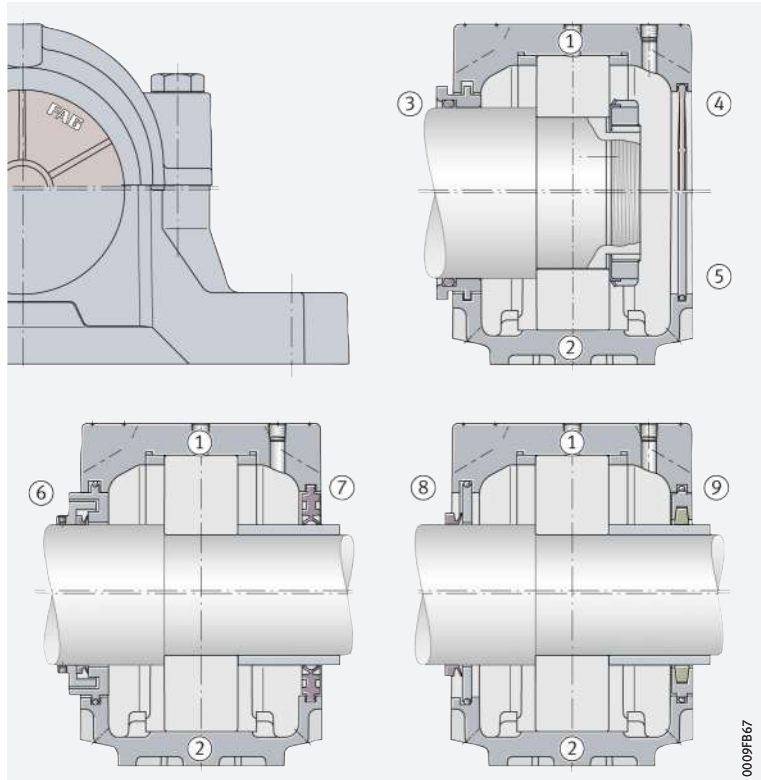

Simplified bearing replacement by means of split bearing

Mounting of split spherical roller bearings

In the case of plummer block housings SNV, an unsplit spherical roller bearing with a tapered bore and adapter sleeve can be replaced by a split spherical roller bearing ▶ 1592 | 8.

8
 Plummer block housing SNV with split and unsplit spherical roller bearing

- ① Locating bearing with unsplit bearing
- ② Non-locating bearing with unsplit bearing
- ③ Locating bearing with split bearing
- ④ Non-locating bearing with split bearing

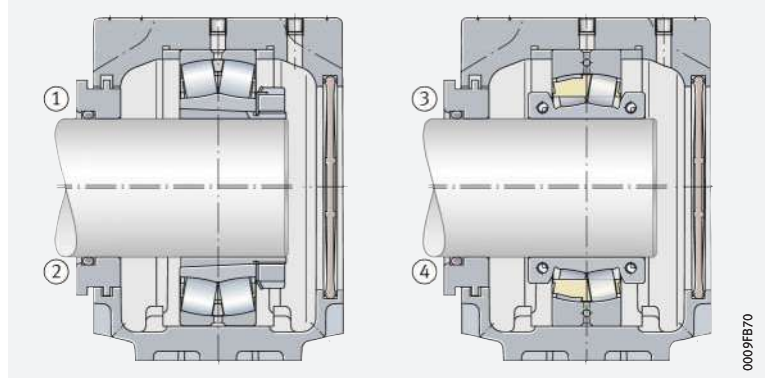

In order to ensure selection of the correct combination of housing and bearing when using split bearings, please contact Schaeffler.



The range of split spherical roller bearings is described in detail in a separate publication ▶ TPI 250.

2.10 Structure of housing designation

The designation of the housings and associated seals, covers and locating rings follows a set model. Description of the designation components ▶ 1592 | 8 to ▶ 1594 | 11. Structure of designations ▶ 1592 | 9 to ▶ 1594 | 12.

8
 Components of the designations of plummer block housings SNV

Characteristic	Code	Description
① Series	SNV	Split plummer block housings SNV
② Bearing outside diameter	340	Outside diameter 340 mm
③ Housing design	F	Threaded holes for grease relubrication and grease outlet
④ Housing material	L	Flake graphite cast iron (standard)
	D	Spheroidal graphite cast iron

9
 Designation structure of plummer block housings SNV, example



9

Components of the designations of standard seals

Characteristic	Code	Description
① Series	DH	Double lip seal, split
	FSV	Felt seal, split
	TSV	Labyrinth seal, unsplit
	DHV	V ring seal, unsplit
	TCV	Taconite seal, unsplit
② Diameter series of bearing, bearing bore	2	Bearings of diameter series 2, cylindrical bearing bore
	3	Bearings of diameter series 3, cylindrical bearing bore
	5	Bearings of diameter series 2, tapered bearing bore and adapter sleeve
	6	Bearings of diameter series 3, tapered bearing bore and adapter sleeve
③ Bore code of bearing	08	Bore diameter (8 · 5) mm = 40 mm
④ Shaft diameter	No further indications	Standard shaft diameter of dimension series
	X105	Inch size shaft diameter: ■ 1 inch + 5 · 1/16 inch = 1 ⁵ / ₁₆ inch

10

Designation structure of standard seals, examples

000A0371



10
 Components of designations
 of covers

Characteristic	Code	Description
① Series	DKV	Cover made from plastic
	DKVT	Cover made from steel and FKM
② Housing size	080	Cover suitable for housing SNV080

11
 Designation structure
 of covers,
 examples



11
 Components of designations
 of locating rings

Characteristic	Code	Description
① Series	FRM	Locating ring
② Outside diameter	80	Outside diameter 80 mm
③ Width	10,5	Width 10,5 mm

12
 Designation structure
 of locating rings,
 example



☞ Separate ordering of housing body and accessories

Ordering examples

When a split plummer block housing SNV is ordered, the housing designation only describes the housing body. The other components such as seals, covers or locating rings must be ordered separately in the specific design required. The rolling bearing and, if necessary, the adapter sleeve must also be ordered separately.

Plummer block housings SNV with a bearing fitted give non-locating bearing arrangements. These can be converted into locating bearing arrangements through the additional insertion of locating rings FRM.

The ordering examples show the construction of orders for selected housing combinations and the appropriate bearings. The allocation of housings, bearings and accessories for all housing sizes is shown in the product tables ► 1598 | .

Example 1

Plummer block housing SNV made from flake graphite cast iron, closed on one side, self-aligning ball bearing 2210-K-TVH-C3 as locating bearing, location by means of an adapter sleeve on shaft diameter of 45 mm, double lip seal.

<i>☞ Order</i>	1 plummer block housing	SNV090-F-L
	1 self-aligning ball bearing	2210-K-TVH-C3
	1 adapter sleeve	H310
	2 locating rings	FRM90/9
	1 cover	DKV090
	1 double lip seal	DH510 (2 pieces per pack)

Example 2

Plummer block housing SNV made from flake graphite cast iron, for continuous shaft, split spherical roller bearing 222SM70-TVPA as locating bearing, double lip seal.

<i>☞ Order</i>	1 plummer block housing	SNV140-F-L
	1 split spherical roller bearing	222SM70-TVPA
	2 locating rings	FRM140/12,5
	2 double lip seals	DH516 (2 pieces per pack)

Example 3

Plummer block housing SNV made from spheroidal graphite cast iron, closed on one side, spherical roller bearing 23218-E1-TVPB as non-locating bearing, felt seal.

<i>☞ Order</i>	1 plummer block housing	SNV160-F-D
	1 spherical roller bearing	23218-E1-TVPB
	1 shaft nut	KM18
	1 tab washer	MB18
	1 cover	DKV160
	1 felt seal	FSV218 (2 pieces per pack)



2.11 Mounting and dismounting

Eye bolts



In the case of housing size SNV215 and larger, the upper housing section has an eye bolt in accordance with DIN 580. This is intended as a locating point for mounting and dismounting of the housing. The load carrying capacity of the eye bolt allows lifting of the housing including a bearing fitted in the housing.



The eye bolt must always be screwed fully into the housing. The eye bolt must not be subjected to a mass greater than that of the housing together with the bearing fitted in the housing.

Foot screws

Foot screws are used for screw mounting of the housing to the mounting surface. They are not included in the scope of delivery of the housings. The appropriate screw size for each housing is given in the product tables ► 1598 | .

Tightening torques for foot screws

The following table contains tightening torques for metric coarse pitch threads in accordance with DIN 13, DIN 962 and DIN ISO 965-2. The tightening torques are maximum values when utilising 90% of the yield stress of the screw material 8.8 and with a friction factor of 0,14. We recommend that foot screws should be tightened to approx. 70% of these values ► 1596 | 12.

12
 Tightening torques for foot screws with metric thread in accordance with DIN 13, DIN 962 and DIN ISO 965-2

Nominal screw diameter	Maximum tightening torque Nm	Recommended tightening torque Nm
M12	93	65
M16	230	160
M20	464	325
M24	798	550
M30	1 597	1 100
M36	2 778	1 950

Detailed information on mounting



Careful and correct mounting of the bearing housing, including the correct mounting of the rolling bearing in the housing, is fundamental to reliable operation. Comprehensive information is given in Catalogue GK 1, Bearing Housings ► <https://www.schaeffler.de/std/1D54>.

2.12 Legal notice regarding data freshness

The further development of products may also result in technical changes to catalogue products

Of central interest to Schaeffler is the further development and optimisation of its products and the satisfaction of its customers. In order that you, as the customer, can keep yourself optimally informed about the progress that is being made here and with regard to the current technical status of the products, we publish any product changes which differ from the printed version in our electronic product catalogue.



We therefore reserve the right to make changes to the data and illustrations in this catalogue. This catalogue reflects the status at the time of printing. More recent publications released by us (as printed or digital media) will automatically precede this catalogue if they involve the same subject. Therefore, please always use our electronic product catalogue to check whether more up-to-date information or modification notices exist for your desired product.

Link to electronic product catalogue



The following link will take you to the Schaeffler electronic product catalogue: ► <https://medias.schaeffler.com>.

2.13 Further information

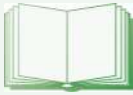

In addition to the data in this chapter, the following chapters must also be observed in the selection of a housing:

- Lubrication ▶ 70|6
- Locating and non-locating bearing concepts ▶ 1571|1.2
- Housing materials ▶ 1573|1.3

Further information:

- Product tables on split plummer block housings SNV for inch size shaft diameters ▶ GK 1
- Electronic housing selection wizard
▶ <https://www.schaeffler.de/std/1D61>





Plummer block housings

SNV, split
For bearings with tapered bore and adapter sleeve, metric shaft

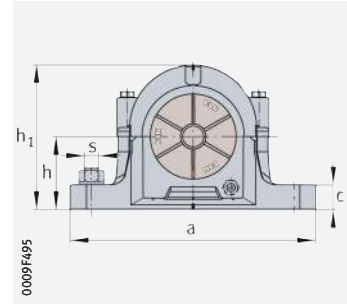
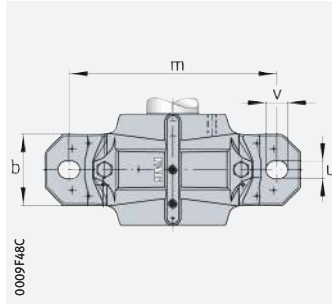

$d_1 = 20 - 35 \text{ mm}$

Shaft d_1 mm	Housing														Housing Designation ► 1592 2.10
	Dimensions													Mass m ≈ kg	
	h	h ₁	g	b	c	a	m	v	u	s		D	g ₃		
										mm	inch				
20	40	75	70	46	19	165	130	20	15	M12	1/2	52	10,5	1,3	SNV052-F-L
	50	91	75	52	22	185	150	20	15	M12	1/2	62	10,5	1,9	SNV062-F-L
	40	75	70	46	19	165	130	20	15	M12	1/2	52	10,5	1,3	SNV052-F-L
	40	75	70	46	19	165	130	20	15	M12	1/2	52	10,5	1,3	SNV052-F-L
	40	75	70	46	19	165	130	20	15	M12	1/2	52	10,5	1,3	SNV052-F-L
	50	91	75	52	22	185	150	20	15	M12	1/2	62	10,5	1,9	SNV062-F-L
25	50	91	75	52	22	185	150	20	15	M12	1/2	62	10,5	1,9	SNV062-F-L
	50	97	80	52	22	185	150	20	15	M12	1/2	72	10,5	2	SNV072-F-L
	50	91	75	52	22	185	150	20	15	M12	1/2	62	10,5	1,9	SNV062-F-L
	50	91	75	52	22	185	150	20	15	M12	1/2	62	10,5	1,9	SNV062-F-L
	50	91	75	52	22	185	150	20	15	M12	1/2	62	10,5	1,9	SNV062-F-L
	50	97	80	52	22	185	150	20	15	M12	1/2	72	10,5	2	SNV072-F-L
30	50	97	80	52	22	185	150	20	15	M12	1/2	72	10,5	2	SNV072-F-L
	60	112	85	60	25	205	170	20	15	M12	1/2	80	10,5	2,9	SNV080-F-L
	50	97	80	52	22	185	150	20	15	M12	1/2	72	10,5	2	SNV072-F-L
	60	112	85	60	25	205	170	20	15	M12	1/2	80	10,5	2,9	SNV080-F-L
	50	97	80	52	22	185	150	20	15	M12	1/2	72	10,5	2	SNV072-F-L
	50	97	80	52	22	185	150	20	15	M12	1/2	72	10,5	2	SNV072-F-L
35	60	112	85	60	25	205	170	20	15	M12	1/2	80	10,5	2,9	SNV080-F-L
	60	117	100	60	25	205	170	20	15	M12	1/2	90	12,5	3,1	SNV090-F-L
	60	112	85	60	25	205	170	20	15	M12	1/2	80	10,5	2,9	SNV080-F-L
	60	117	100	60	25	205	170	20	15	M12	1/2	90	12,5	3,1	SNV090-F-L
	60	112	85	60	25	205	170	20	15	M12	1/2	80	10,5	2,9	SNV080-F-L
	60	112	85	60	25	205	170	20	15	M12	1/2	80	10,5	2,9	SNV080-F-L
	60	117	100	60	25	205	170	20	15	M12	1/2	90	12,5	3,1	SNV090-F-L
	60	117	100	60	25	205	170	20	15	M12	1/2	90	12,5	3,1	SNV090-F-L

medias ► <https://www.schaeffler.de/std/1E88>

① Locating bearing; ② Non-locating bearing

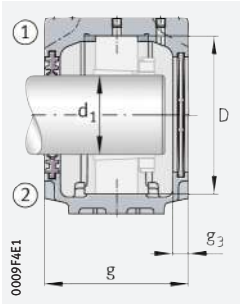

Double lip seal DH
Cover DKV

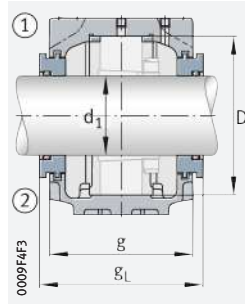

Labyrinth seal TSV

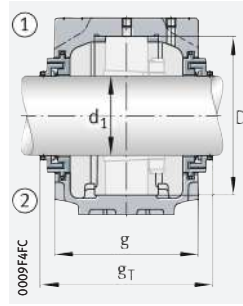

Taconite seal TCV

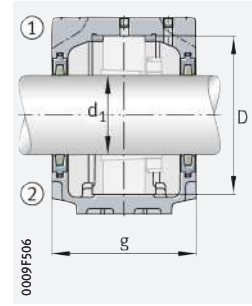

Felt seal FSV

Bearings and accessories

Bearing	Adapter sleeve	Locating ring 2 pieces	Double lip seal	Felt seal	Labyrinth seal		V ring seal		Taconite seal		Cover
					g_L mm		g_v mm		g_T mm		
1205-K	H205	FRM52/6	DH505	FSV505	TSV505	83	DHV505	76	-	-	DKV052
1305-K	H305	FRM62/6,5	DH605	FSV605	TSV605	88	DHV605	81	-	-	DKV062
20205-K	H205	FRM52/6	DH505	FSV505	TSV505	83	DHV505	76	-	-	DKV052
2205-K	H305	FRM52/4,5	DH505	FSV505	TSV505	83	DHV505	76	-	-	DKV052
22205..-K	H305	FRM52/4,5	DH505	FSV505	TSV505	83	DHV505	76	-	-	DKV052
2305-K	H2305	FRM62/3	DH605	FSV605	TSV605	88	DHV605	81	-	-	DKV062
1206-K	H206	FRM62/7	DH506	FSV506	TSV506	88	DHV506	81	-	-	DKV062
1306-K	H306	FRM72/7	DH606	FSV606	TSV606	93	DHV606	86	TCV606	117	DKV072
20206-K	H206	FRM62/7	DH506	FSV506	TSV506	88	DHV506	81	-	-	DKV062
2206-K	H306	FRM62/5	DH506	FSV506	TSV506	88	DHV506	81	-	-	DKV062
22206..-K	H306	FRM62/5	DH506	FSV506	TSV506	88	DHV506	81	-	-	DKV062
2306-K	H2306	FRM72/3	DH606	FSV606	TSV606	93	DHV606	86	TCV606	117	DKV072
1207-K	H207	FRM72/8	DH507	FSV507	TSV507	93	DHV507	86	-	-	DKV072
1307-K	H307	FRM80/9	DH607	FSV607	TSV607	98	DHV607	91	TCV607	122	DKV080
20207-K	H207	FRM72/8	DH507	FSV507	TSV507	93	DHV507	86	-	-	DKV072
21307..-K	H307	FRM80/9	DH607	FSV607	TSV607	98	DHV607	91	TCV607	122	DKV080
2207-K	H307	FRM72/5	DH507	FSV507	TSV507	93	DHV507	86	-	-	DKV072
22207..-K	H307	FRM72/5	DH507	FSV507	TSV507	93	DHV507	86	-	-	DKV072
2307-K	H2307	FRM80/4	DH607	FSV607	TSV607	98	DHV607	91	TCV607	122	DKV080
1208-K	H208	FRM80/10,5	DH508	FSV508	TSV508	98	DHV508	91	TCV508	122	DKV080
1308-K	H308	FRM90/9	DH608	FSV608	TSV608	114	DHV608	104	TCV608	136	DKV090
20208-K	H208	FRM80/10,5	DH508	FSV508	TSV508	98	DHV508	91	TCV508	122	DKV080
21308..-K	H308	FRM90/9	DH608	FSV608	TSV608	114	DHV608	104	TCV608	136	DKV090
2208-K	H308	FRM80/8	DH508	FSV508	TSV508	98	DHV508	91	TCV508	122	DKV080
22208..-K	H308	FRM80/8	DH508	FSV508	TSV508	98	DHV508	91	TCV508	122	DKV080
22308..-K	H2308	FRM90/4	DH608	FSV608	TSV608	114	DHV608	104	TCV608	136	DKV090
2308-K	H2308	FRM90/4	DH608	FSV608	TSV608	114	DHV608	104	TCV608	136	DKV090





Plummer block housings

SNV, split
For bearings with tapered bore and adapter sleeve, metric shaft

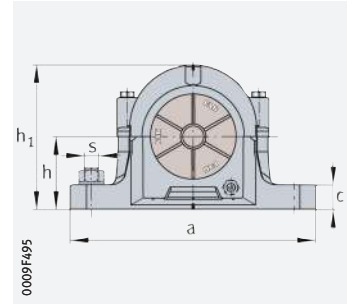
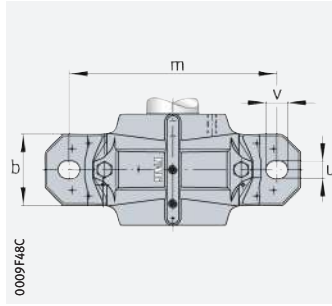

$d_1 = 40 - 50 \text{ mm}$

Shaft d_1 mm	Housing													Housing Designation ► 1592 2.10	
	Dimensions												Mass m ≈ kg		
	h	h ₁	g	b	c	a	m	v	u	s	D	g ₃			
										mm	inch				
40	60	114	87	60	25	205	170	20	15	M12	1/2	85	12,5	2,8	SNV085-F-L
	70	133	105	70	28	255	210	23	18	M16	5/8	100	12,5	4,3	SNV100-F-L
	60	114	87	60	25	205	170	20	15	M12	1/2	85	12,5	2,8	SNV085-F-L
	70	133	105	70	28	255	210	23	18	M16	5/8	100	12,5	4,3	SNV100-F-L
	60	114	87	60	25	205	170	20	15	M12	1/2	85	12,5	2,8	SNV085-F-L
	60	114	87	60	25	205	170	20	15	M12	1/2	85	12,5	2,8	SNV085-F-L
	70	133	105	70	28	255	210	23	18	M16	5/8	100	12,5	4,3	SNV100-F-L
	70	133	105	70	28	255	210	23	18	M16	5/8	100	12,5	4,3	SNV100-F-L
45	60	117	100	60	25	205	170	20	15	M12	1/2	90	12,5	3,1	SNV090-F-L
	70	139	110	70	30	255	210	23	18	M16	5/8	110	12,5	4,9	SNV110-F-L
	60	117	100	60	25	205	170	20	15	M12	1/2	90	12,5	3,1	SNV090-F-L
	70	139	110	70	30	255	210	23	18	M16	5/8	110	12,5	4,9	SNV110-F-L
	60	117	100	60	25	205	170	20	15	M12	1/2	90	12,5	3,1	SNV090-F-L
	60	117	100	60	25	205	170	20	15	M12	1/2	90	12,5	3,1	SNV090-F-L
	70	139	110	70	30	255	210	23	18	M16	5/8	110	12,5	4,9	SNV110-F-L
	70	139	110	70	30	255	210	23	18	M16	5/8	110	12,5	4,9	SNV110-F-L
50	70	133	105	70	28	255	210	23	18	M16	5/8	100	12,5	4,3	SNV100-F-L
	80	155	115	80	30	275	230	23	18	M16	5/8	120	12,5	6,1	SNV120-F-L
	70	133	105	70	28	255	210	23	18	M16	5/8	100	12,5	4,3	SNV100-F-L
	80	155	115	80	30	275	230	23	18	M16	5/8	120	12,5	6,1	SNV120-F-L
	80	155	115	80	30	275	230	23	18	M16	5/8	120	12,5	6,1	SNV120-F-L
	70	133	105	70	28	255	210	23	18	M16	5/8	100	12,5	4,3	SNV100-F-L
	70	133	105	70	28	255	210	23	18	M16	5/8	100	12,5	4,3	SNV100-F-L
	80	155	115	80	30	275	230	23	18	M16	5/8	120	12,5	6,1	SNV120-F-L

medias ► <https://www.schaeffler.de/std/1E89>

① Locating bearing; ② Non-locating bearing

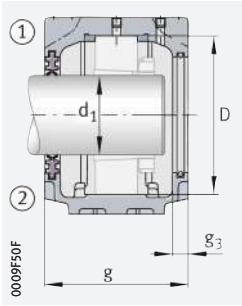

Double lip seal DH
Cover DKVT

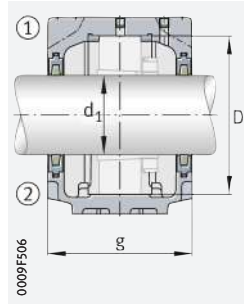

Felt seal FSV

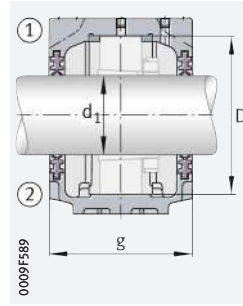

Double lip seal DH

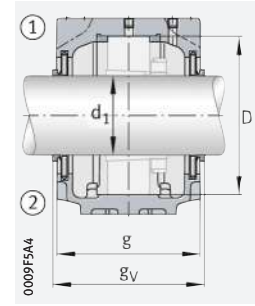

V ring seal DHV

Bearings and accessories

Bearing	Adapter sleeve	Locating ring 2 pieces	Double lip seal	Felt seal	Labyrinth seal		V ring seal		Taconite seal		Cover
					g_L mm	g_V mm	g_T mm	g_T mm			
1209-K	H209	FRM85/6	DH509	FSV509	TSV509	101	DHV509	93	TCV509	125	DKV085
1309-K	H309	FRM100/9,5	DH609	FSV609	TSV609	119	DHV609	111	TCV609	143	DKV100
20209-K	H209	FRM85/6	DH509	FSV509	TSV509	101	DHV509	93	TCV509	125	DKV085
21309...-K	H309	FRM100/9,5	DH609	FSV609	TSV609	119	DHV609	111	TCV609	143	DKV100
2209-K	H309	FRM85/4	DH509	FSV509	TSV509	101	DHV509	93	TCV509	125	DKV085
22209...-K	H309	FRM85/4	DH509	FSV509	TSV509	101	DHV509	93	TCV509	125	DKV085
22309...-K	H2309	FRM100/4	DH609	FSV609	TSV609	119	DHV609	111	TCV609	143	DKV100
2309-K	H2309	FRM100/4	DH609	FSV609	TSV609	119	DHV609	111	TCV609	143	DKV100
1210-K	H210	FRM90/10,5	DH510	FSV510	TSV510	114	DHV510	106	TCV510	138	DKV090
1310-K	H310	FRM110/10,5	DH610	FSV610	TSV610	124	DHV610	116	TCV610	148	DKV110
20210-K	H210	FRM90/10,5	DH510	FSV510	TSV510	114	DHV510	106	TCV510	138	DKV090
21310...-K	H310	FRM110/10,5	DH610	FSV610	TSV610	124	DHV610	116	TCV610	148	DKV110
2210-K	H310	FRM90/9	DH510	FSV510	TSV510	114	DHV510	106	TCV510	138	DKV090
22210...-K	H310	FRM90/9	DH510	FSV510	TSV510	114	DHV510	106	TCV510	138	DKV090
22310...-K	H2310	FRM110/4	DH610	FSV610	TSV610	124	DHV610	116	TCV610	148	DKV110
2310-K	H2310	FRM110/4	DH610	FSV610	TSV610	124	DHV610	116	TCV610	148	DKV110
1211-K	H211	FRM100/11,5	DH511	FSV511	TSV511	119	DHV511	111	TCV511	143	DKV100
1311-K	H311	FRM120/11	DH611	FSV611	TSV611	129	DHV611	121	TCV611	153	DKV120
20211-K	H211	FRM100/11,5	DH511	FSV511	TSV511	119	DHV511	111	TCV511	143	DKV100
20311-K	H311	FRM120/11	DH611	FSV611	TSV611	129	DHV611	121	TCV611	153	DKV120
21311...-K	H311	FRM120/11	DH611	FSV611	TSV611	129	DHV611	121	TCV611	153	DKV120
2211-K	H311	FRM100/9,5	DH511	FSV511	TSV511	119	DHV511	111	TCV511	143	DKV100
22211...-K	H311	FRM100/9,5	DH511	FSV511	TSV511	119	DHV511	111	TCV511	143	DKV100
22311...-K	H2311	FRM120/4	DH611	FSV611	TSV611	129	DHV611	121	TCV611	153	DKV120
2311-K	H2311	FRM120/4	DH611	FSV611	TSV611	129	DHV611	121	TCV611	153	DKV120





Plummer block housings

SNV, split
For bearings with tapered bore and adapter sleeve, metric shaft

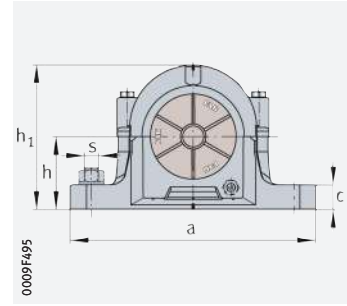
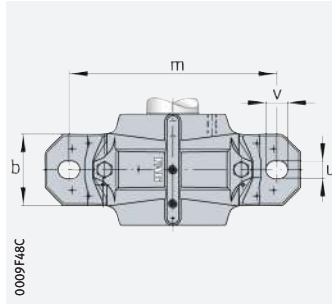

$d_1 = 55 - 65 \text{ mm}$

Shaft d_1 mm	Housing													Housing Designation ► 1592 2.10	
	Dimensions												Mass m ≈ kg		
	h	h_1	g	b	c	a	m	v	u	s		D			g_3
										mm	inch				
55	70	139	110	70	30	255	210	23	18	M16	5/8	110	12,5	4,9	SNV110-F-L
	80	161	120	80	30	280	230	23	18	M16	5/8	130	12,5	6,8	SNV130-F-L
	70	139	110	70	30	255	210	23	18	M16	5/8	110	12,5	4,9	SNV110-F-L
	80	161	120	80	30	280	230	23	18	M16	5/8	130	12,5	6,8	SNV130-F-L
	80	161	120	80	30	280	230	23	18	M16	5/8	130	12,5	6,8	SNV130-F-L
	70	139	110	70	30	255	210	23	18	M16	5/8	110	12,5	4,9	SNV110-F-L
	70	139	110	70	30	255	210	23	18	M16	5/8	110	12,5	4,9	SNV110-F-L
	80	161	120	80	30	280	230	23	18	M16	5/8	130	12,5	6,8	SNV130-F-L
60	80	155	115	80	30	275	230	23	18	M16	5/8	120	12,5	6,1	SNV120-F-L
	95	183	135	90	32	315	260	27	22	M20	3/4	140	15	9,3	SNV140-F-L
	80	155	115	80	30	275	230	23	18	M16	5/8	120	12,5	6,1	SNV120-F-L
	95	183	135	90	32	315	260	27	22	M20	3/4	140	15	9,3	SNV140-F-L
	95	183	135	90	32	315	260	27	22	M20	3/4	140	15	9,3	SNV140-F-L
	95	183	135	90	32	315	260	27	22	M20	3/4	140	15	9,3	SNV140-F-L
	80	155	115	80	30	275	230	23	18	M16	5/8	120	12,5	6,1	SNV120-F-L
	80	155	115	80	30	275	230	23	18	M16	5/8	120	12,5	6,1	SNV120-F-L
65	80	161	120	80	30	280	230	23	18	M16	5/8	130	12,5	6,8	SNV130-F-L
	100	201	145	100	35	345	290	27	22	M20	3/4	160	15	12,8	SNV160-F-L
	80	161	120	80	30	280	230	23	18	M16	5/8	130	12,5	6,8	SNV130-F-L
	100	201	145	100	35	345	290	27	22	M20	3/4	160	15	12,8	SNV160-F-L
	80	161	120	80	30	280	230	23	18	M16	5/8	130	12,5	6,8	SNV130-F-L
	80	161	120	80	30	280	230	23	18	M16	5/8	130	12,5	6,8	SNV130-F-L
	100	201	145	100	35	345	290	27	22	M20	3/4	160	15	12,8	SNV160-F-L
	100	201	145	100	35	345	290	27	22	M20	3/4	160	15	12,8	SNV160-F-L

medias ► <https://www.schaeffler.de/std/1E8A>

① Locating bearing; ② Non-locating bearing

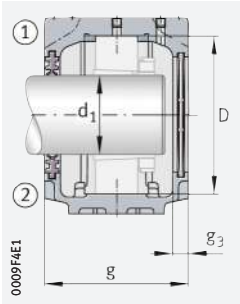

Double lip seal DH
Cover DKV

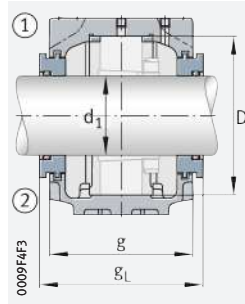

Labyrinth seal TSV

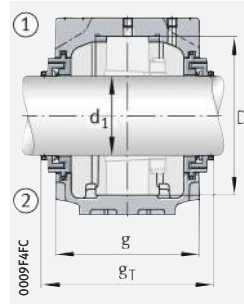

Taconite seal TCV

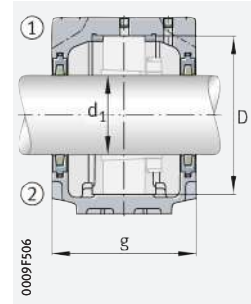

Felt seal FSV

Bearings and accessories

Bearing	Adapter sleeve	Locating ring 2 pieces	Double lip seal	Felt seal	Labyrinth seal		V ring seal		Taconite seal		Cover
						gL mm		gV mm		gT mm	
1212-K	H212	FRM110/13	DH512	FSV512	TSV512	124	DHV512	116	TCV512	148	DKV110
1312-K	H312	FRM130/12,5	DH612	FSV612	TSV612	134	DHV612	126	TCV612	158	DKV130
20212-K	H212	FRM110/13	DH512	FSV512	TSV512	124	DHV512	116	TCV512	148	DKV110
20312-K	H312	FRM130/12,5	DH612	FSV612	TSV612	134	DHV612	126	TCV612	158	DKV130
21312...K	H312	FRM130/12,5	DH612	FSV612	TSV612	134	DHV612	126	TCV612	158	DKV130
2212-K	H312	FRM110/10	DH512	FSV512	TSV512	124	DHV512	116	TCV512	148	DKV110
22212...K	H312	FRM110/10	DH512	FSV512	TSV512	124	DHV512	116	TCV512	148	DKV110
22312...K	H2312	FRM130/5	DH612	FSV612	TSV612	134	DHV612	126	TCV612	158	DKV130
2312-K	H2312	FRM130/5	DH612	FSV612	TSV612	134	DHV612	126	TCV612	158	DKV130
1213-K	H213	FRM120/14	DH513	FSV513	TSV513	129	DHV513	121	TCV513	153	DKV120
1313-K	H313	FRM140/12,5	DH613	FSV613	TSV613	150,3	DHV613	139	TCV613	172	DKV140
20213-K	H213	FRM120/14	DH513	FSV513	TSV513	129	DHV513	121	TCV513	153	DKV120
20313-K	H313	FRM140/12,5	DH613	FSV613	TSV613	150,3	DHV613	139	TCV613	172	DKV140
21313...K	H313	FRM140/12,5	DH613	FSV613	TSV613	150,3	DHV613	139	TCV613	172	DKV140
2213-K	H313	FRM120/10	DH513	FSV513	TSV513	129	DHV513	121	TCV513	153	DKV120
22213...K	H313	FRM120/10	DH513	FSV513	TSV513	129	DHV513	121	TCV513	153	DKV120
22313...K	H2313	FRM140/5	DH613	FSV613	TSV613	150,3	DHV613	139	TCV613	172	DKV140
2313-K	H2313	FRM140/5	DH613	FSV613	TSV613	150,3	DHV613	139	TCV613	172	DKV140
1215-K	H215	FRM130/15,5	DH515	FSV515	TSV515	134	DHV515	126	TCV515	158	DKV130
1315-K	H315	FRM160/14	DH615	FSV615	TSV615	160,3	DHV615	149	TCV615	182	DKV160
20215-K	H215	FRM130/15,5	DH515	FSV515	TSV515	134	DHV515	126	TCV515	158	DKV130
21315...K	H315	FRM160/14	DH615	FSV615	TSV615	160,3	DHV615	149	TCV615	182	DKV160
2215-K	H315	FRM130/12,5	DH515	FSV515	TSV515	134	DHV515	126	TCV515	158	DKV130
22215...K	H315	FRM130/12,5	DH515	FSV515	TSV515	134	DHV515	126	TCV515	158	DKV130
22315...K	H2315	FRM160/5	DH615	FSV615	TSV615	160,3	DHV615	149	TCV615	182	DKV160
2315-K	H2315	FRM160/5	DH615	FSV615	TSV615	160,3	DHV615	149	TCV615	182	DKV160



Plummer block housings

SNV, split
For bearings with tapered bore and adapter sleeve, metric shaft

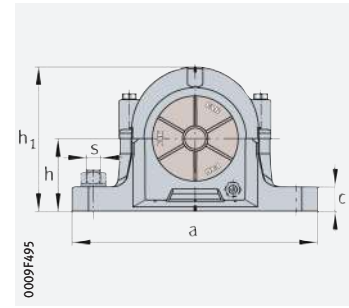
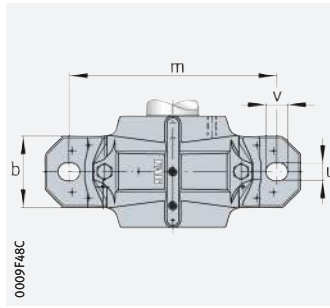

$d_1 = 70 - 80 \text{ mm}$

Shaft d_1 mm	Housing													Housing Designation ► 1592 2.10	
	Dimensions												Mass m ≈ kg		
	h	h ₁	g	b	c	a	m	v	u	s		D			g ₃
										mm	inch				
70	95	183	135	90	32	315	260	27	22	M20	3/4	140	15	9,3	SNV140-F-L
	112	219	150	100	35	345	290	27	22	M20	3/4	170	16	14,4	SNV170-F-L
	95	183	135	90	32	315	260	27	22	M20	3/4	140	15	9,3	SNV140-F-L
	112	219	150	100	35	345	290	27	22	M20	3/4	170	16	14,4	SNV170-F-L
	95	183	135	90	32	315	260	27	22	M20	3/4	140	15	9,3	SNV140-F-L
	95	183	135	90	32	315	260	27	22	M20	3/4	140	15	9,3	SNV140-F-L
	112	219	150	100	35	345	290	27	22	M20	3/4	170	16	14,4	SNV170-F-L
75	95	189	140	90	32	320	260	27	22	M20	3/4	150	15	9,9	SNV150-F-L
	112	223	160	110	40	380	320	32	26	M24	7/8	180	16	17	SNV180-F-L
	95	189	140	90	32	320	260	27	22	M20	3/4	150	15	9,9	SNV150-F-L
	112	223	160	110	40	380	320	32	26	M24	7/8	180	16	17	SNV180-F-L
	95	189	140	90	32	320	260	27	22	M20	3/4	150	15	9,9	SNV150-F-L
	95	189	140	90	32	320	260	27	22	M20	3/4	150	15	9,9	SNV150-F-L
	112	223	160	110	40	380	320	32	26	M24	7/8	180	16	17	SNV180-F-L
80	100	201	145	100	35	345	290	27	22	M20	3/4	160	15	12,8	SNV160-F-L
	112	229	155	110	40	380	320	32	26	M24	7/8	190	15	22	SNV190-F-L
	100	201	145	100	35	345	290	27	22	M20	3/4	160	15	12,8	SNV160-F-L
	112	229	155	110	40	380	320	32	26	M24	7/8	190	15	22	SNV190-F-L
	112	229	155	110	40	380	320	32	26	M24	7/8	190	15	22	SNV190-F-L
	100	201	145	100	35	345	290	27	22	M20	3/4	160	15	12,8	SNV160-F-L
	100	201	145	100	35	345	290	27	22	M20	3/4	160	15	12,8	SNV160-F-L
	112	229	155	110	40	380	320	32	26	M24	7/8	190	15	22	SNV190-F-L
	112	229	155	110	40	380	320	32	26	M24	7/8	190	15	22	SNV190-F-L
100	201	145	100	35	345	290	27	22	M20	3/4	160	15	12,8	SNV160-F-L	

medias ► <https://www.schaeffler.de/std/1E8B>

① Locating bearing; ② Non-locating bearing

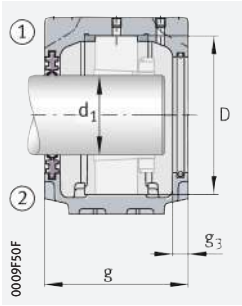

Double lip seal DH
Cover DKVT

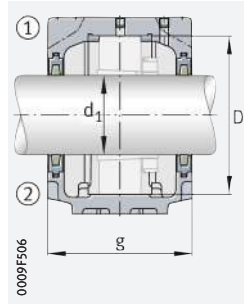

Felt seal FSV

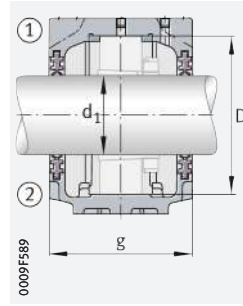

Double lip seal DH

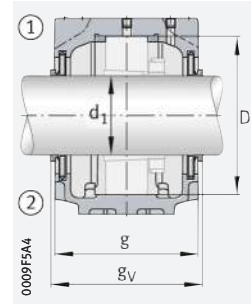

V ring seal DHV

Bearings and accessories

Bearing	Adapter sleeve	Locating ring 2 pieces	Double lip seal	Felt seal	Labyrinth seal		V ring seal		Taconite seal		Cover
						gL mm		gv mm		gT mm	
1216-K	H216	FRM140/16	DH516	FSV516	TSV516	150,3	DHV516	143	TCV516	176	DKV140
1316-K	H316	FRM170/14,5	DH616	FSV616	TSV616	167,3	DHV616	158	TCV616	193	DKV170
20216-K	H216	FRM140/16	DH516	FSV516	TSV516	150,3	DHV516	143	TCV516	176	DKV140
21316...-K	H316	FRM170/14,5	DH616	FSV616	TSV616	167,3	DHV616	158	TCV616	193	DKV170
2216-K	H316	FRM140/12,5	DH516	FSV516	TSV516	150,3	DHV516	143	TCV516	176	DKV140
22216...-K	H316	FRM140/12,5	DH516	FSV516	TSV516	150,3	DHV516	143	TCV516	176	DKV140
22316...-K	H2316	FRM170/5	DH616	FSV616	TSV616	167,3	DHV616	158	TCV616	193	DKV170
2316-K	H2316	FRM170/5	DH616	FSV616	TSV616	167,3	DHV616	158	TCV616	193	DKV170
1217-K	H217	FRM150/16,5	DH517	FSV517	TSV517	155,3	DHV517	148	TCV517	181	DKV150
1317-K	H317	FRM180/14,5	DH617	FSV617	TSV617	177,3	DHV617	168	TCV617	203	DKV180
20217-K	H217	FRM150/16,5	DH517	FSV517	TSV517	155,3	DHV517	148	TCV517	181	DKV150
21317...-K	H317	FRM180/14,5	DH617	FSV617	TSV617	177,3	DHV617	168	TCV617	203	DKV180
2217-K	H317	FRM150/12,5	DH517	FSV517	TSV517	155,3	DHV517	148	TCV517	181	DKV150
22217...-K	H317	FRM150/12,5	DH517	FSV517	TSV517	155,3	DHV517	148	TCV517	181	DKV150
22317...-K	H2317	FRM180/5	DH617	FSV617	TSV617	177,3	DHV617	168	TCV617	203	DKV180
2317-K	H2317	FRM180/5	DH617	FSV617	TSV617	177,3	DHV617	168	TCV617	203	DKV180
1218-K	H218	FRM160/17,5	DH518	FSV518	TSV518	160,3	DHV518	153	TCV518	186	DKV160
1318-K	H318	FRM190/15,5	DH518	FSV518	TSV518	170,3	DHV518	163	TCV518	178	DKV160
20218-K	H218	FRM160/17,5	DH518	FSV518	TSV518	160,3	DHV518	153	TCV518	186	DKV160
20318-K	H318	FRM190/15,5	DH518	FSV518	TSV518	170,3	DHV518	163	TCV518	178	DKV160
21318...-K	H318	FRM190/15,5	DH518	FSV518	TSV518	170,3	DHV518	163	TCV518	178	DKV160
2218-K	H318	FRM160/12,5	DH518	FSV518	TSV518	160,3	DHV518	153	TCV518	186	DKV160
22218...-K	H318	FRM160/12,5	DH518	FSV518	TSV518	160,3	DHV518	153	TCV518	186	DKV160
22318...-K	H2318	FRM190/5	DH518	FSV518	TSV518	170,3	DHV518	163	TCV518	178	DKV160
2318-K	H2318	FRM190/5	DH518	FSV518	TSV518	170,3	DHV518	163	TCV518	178	DKV160
23218...-K	H2318	FRM160/6,3	DH518	FSV518	TSV518	160,3	DHV518	153	TCV518	186	DKV160



Plummer block housings

SNV, split
For bearings with tapered bore and adapter sleeve, metric shaft

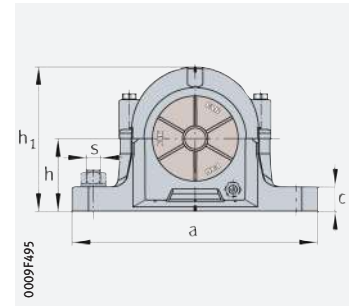
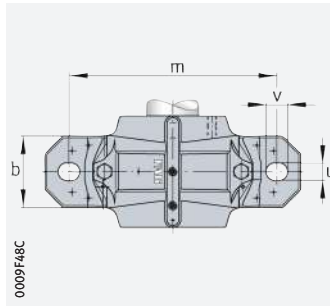

d₁ = 85 – 110 mm

Shaft d ₁ mm	Housing														Housing Designation ► 1592 2.10
	Dimensions													Mass m ≈ kg	
	h	h ₁	g	b	c	a	m	v	u	s	D	g ₃			
									mm	inch					
85	112	219	150	100	35	345	290	27	22	M20	3/4	170	16	14,4	SNV170-F-L
	125	248	175	120	45	410	350	32	26	M24	7/8	200	16	21	SNV200-F-L
	125	248	175	120	45	410	350	32	26	M24	7/8	200	16	21	SNV200-F-L
	112	219	150	100	35	345	290	27	22	M20	3/4	170	16	14,4	SNV170-F-L
	112	219	150	100	35	345	290	27	22	M20	3/4	170	16	14,4	SNV170-F-L
	125	248	175	120	45	410	350	32	26	M24	7/8	200	16	21	SNV200-F-L
	125	248	175	120	45	410	350	32	26	M24	7/8	200	16	21	SNV200-F-L
90	112	223	160	110	40	380	320	32	26	M24	7/8	180	16	17	SNV180-F-L
	140	271	180	120	45	410	350	32	26	M24	7/8	215	16	24,5	SNV215-F-L ¹⁾
	112	223	160	110	40	380	320	32	26	M24	7/8	180	16	17	SNV180-F-L
	140	271	180	120	45	410	350	32	26	M24	7/8	215	16	24,5	SNV215-F-L ¹⁾
	140	271	180	120	45	410	350	32	26	M24	7/8	215	16	24,5	SNV215-F-L ¹⁾
	112	223	160	110	40	380	320	32	26	M24	7/8	180	16	17	SNV180-F-L
	112	223	160	110	40	380	320	32	26	M24	7/8	180	16	17	SNV180-F-L
	140	271	180	120	45	410	350	32	26	M24	7/8	215	16	24,5	SNV215-F-L ¹⁾
	140	271	180	120	45	410	350	32	26	M24	7/8	215	16	24,5	SNV215-F-L ¹⁾
100	125	248	175	120	45	410	350	32	26	M24	7/8	200	16	21	SNV200-F-L
	150	298	185	130	50	450	390	35	28	M24	1	240	18	32	SNV240-F-L ¹⁾
	125	248	175	120	45	410	350	32	26	M24	7/8	200	16	21	SNV200-F-L
	150	298	185	130	50	450	390	35	28	M24	1	240	18	32	SNV240-F-L ¹⁾
	125	248	175	120	45	410	350	32	26	M24	7/8	200	16	21	SNV200-F-L
	125	248	175	120	45	410	350	32	26	M24	7/8	200	16	21	SNV200-F-L
	150	298	185	130	50	450	390	35	28	M24	1	240	18	32	SNV240-F-L ¹⁾
	125	248	175	120	45	410	350	32	26	M24	7/8	200	16	21	SNV200-F-L
110	140	271	180	120	45	410	350	32	26	M24	7/8	215	16	24,5	SNV215-F-L ¹⁾
	140	271	180	120	45	410	350	32	26	M24	7/8	215	16	24,5	SNV215-F-L ¹⁾
	160	321	190	160	60	530	450	42	35	M30	1 1/4	260	18	48	SNV260-F-L ¹⁾
	140	271	180	120	45	410	350	32	26	M24	7/8	215	16	24,5	SNV215-F-L ¹⁾

medias ► <https://www.schaeffler.de/std/1E8C>

① Locating bearing; ② Non-locating bearing

1) Housing with eye bolt.

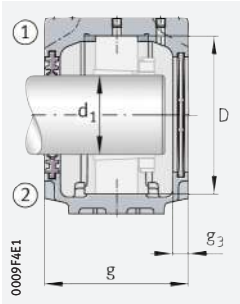

Double lip seal DH
Cover DKV

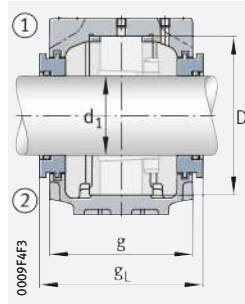

Labyrinth seal TSV

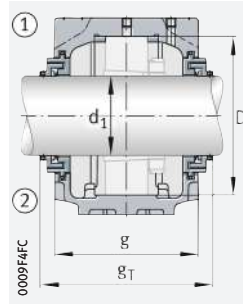

Taconite seal TCV

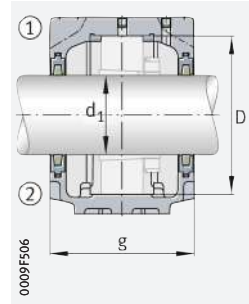

Felt seal FSV

Bearings and accessories

Bearing	Adapter sleeve	Locating ring 2 pieces	Double lip seal	Felt seal	Labyrinth seal		V ring seal		Taconite seal		Cover
					g_L mm	g_T mm	g_V mm	g_T mm			
1219-K	H219	FRM170/18	DH519	FSV519	TSV519	167,3	DHV519	158	TCV519	193	DKV170
1319-K	H319	FRM200/17,5	DH619	FSV619	TSV619	192,3	DHV619	183	TCV619	218	DKV200
21319...-K	H319	FRM200/17,5	DH619	FSV619	TSV619	192,3	DHV619	183	TCV619	218	DKV200
2219-K	H319	FRM170/12,5	DH519	FSV519	TSV519	167,3	DHV519	158	TCV519	193	DKV170
22219...-K	H319	FRM170/12,5	DH519	FSV519	TSV519	167,3	DHV519	158	TCV519	193	DKV170
22319...-K	H2319	FRM200/6,5	DH619	FSV619	TSV619	192,3	DHV619	183	TCV619	218	DKV200
2319-K	H2319	FRM200/6,5	DH619	FSV619	TSV619	192,3	DHV619	183	TCV619	218	DKV200
1220-K	H220	FRM180/18	DH520	FSV520	TSV520	177,3	DHV520	168	TCV520	203	DKV180
1320-K	H320	FRM215/19,5	DH620	FSV620	TSV620	197,3	DHV620	188	TCV620	224	DKV215
20220-K	H220	FRM180/18	DH520	FSV520	TSV520	177,3	DHV520	168	TCV520	203	DKV180
20320-K	H320	FRM215/19,5	DH620	FSV620	TSV620	197,3	DHV620	188	TCV620	224	DKV215
21320...-K	H320	FRM215/19,5	DH620	FSV620	TSV620	197,3	DHV620	188	TCV620	224	DKV215
2220-K	H320	FRM180/12	DH520	FSV520	TSV520	177,3	DHV520	168	TCV520	203	DKV180
22220...-K	H320	FRM180/12	DH520	FSV520	TSV520	177,3	DHV520	168	TCV520	203	DKV180
22320...-K	H2320	FRM215/6,5	DH620	FSV620	TSV620	197,3	DHV620	188	TCV620	224	DKV215
2320-K	H2320	FRM215/6,5	DH620	FSV620	TSV620	197,3	DHV620	188	TCV620	224	DKV215
23220...-K	H2320	FRM180/4,85	DH520	FSV520	TSV520	177,3	DHV520	168	TCV520	203	DKV180
1222-K	H222	FRM200/21	DH522	FSV522	TSV522	195,3	DHV522	183	TCV522	218	DKV200
1322-K	H322	FRM240/20	DH522	FSV522	TSV522	203,3	DHV522	191	TCV522	226	DKV200
20222-K	H222	FRM200/21	DH522	FSV522	TSV522	195,3	DHV522	183	TCV522	218	DKV200
21322...-K	H322	FRM240/20	DH522	FSV522	TSV522	203,3	DHV522	191	TCV522	226	DKV200
22222...-K	H322	FRM200/13,5	DH522	FSV522	TSV522	195,3	DHV522	183	TCV522	218	DKV200
2222-K	H322	FRM200/13,5	DH522	FSV522	TSV522	195,3	DHV522	183	TCV522	218	DKV200
22322...-K	H2322	FRM240/5	DH522	FSV522	TSV522	203,3	DHV522	191	TCV522	226	DKV200
23222...-K	H2322	FRM200/5,1	DH522	FSV522	TSV522	195,3	DHV522	183	TCV522	218	DKV200
2322-K	H2322	FRM240/5	DH522	FSV522	TSV522	203,3	DHV522	191	TCV522	226	DKV200
20224-K	H3024	FRM215/23	DH524	FSV524	TSV524	200,3	DHV524	191	TCV524	227	DKV215
22224...-K	H3124	FRM215/14	DH524	FSV524	TSV524	200,3	DHV524	191	TCV524	227	DKV215
22324...-K	H2324	FRM260/5	DH524	FSV524	TSV524	208,3	DHV524	199	TCV524	235	DKV215
23224...-K	H2324	FRM215/5	DH524	FSV524	TSV524	200,3	DHV524	191	TCV524	227	DKV215





Plummer block housings

SNV, split
For bearings with tapered bore and adapter sleeve, metric shaft

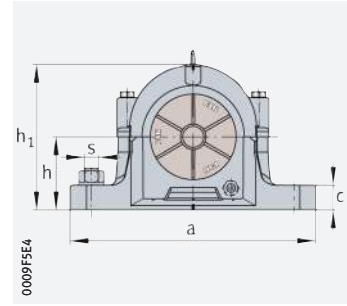
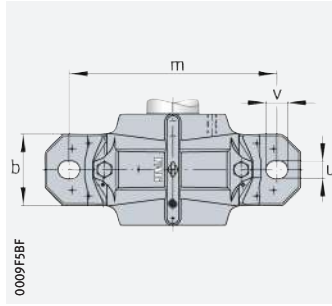

$d_1 = 115 - 140 \text{ mm}$

Shaft d_1 mm	Housing														Housing Designation ► 1592 2.10
	Dimensions													Mass m ≈ kg	
	h	h ₁	g	b	c	a	m	v	u	s		D	g ₃		
										mm	inch				
115	150	291	190	130	50	445	380	35	28	M24	1	230	18	30	SNV230-F-L
	150	291	190	130	50	445	380	35	28	M24	1	230	18	30	SNV230-F-L
	170	344	205	160	60	550	470	42	35	M30	1 ¹ / ₄	280	18	55	SNV280-F-L
	150	291	190	130	50	445	380	35	28	M24	1	230	18	30	SNV230-F-L
125	150	304	200	150	50	500	420	42	35	M30	1 ¹ / ₄	250	18	38	SNV250-F-L
	150	304	200	150	50	500	420	42	35	M30	1 ¹ / ₄	250	18	38	SNV250-F-L
	180	366	215	170	65	620	520	42	35	M30	1 ¹ / ₄	300	18	70	SNV300-F-L
	150	304	200	150	50	500	420	42	35	M30	1 ¹ / ₄	250	18	38	SNV250-F-L
135	160	328	215	160	60	530	450	42	35	M30	1 ¹ / ₄	270	18	45,5	SNV270-F-L
	160	328	215	160	60	530	450	42	35	M30	1 ¹ / ₄	270	18	45,5	SNV270-F-L
	190	386	225	180	65	650	560	42	35	M30	1 ¹ / ₄	320	18	95	SNV320-F-L
	160	328	215	160	60	530	450	42	35	M30	1 ¹ / ₄	270	18	45,5	SNV270-F-L
140	170	351	225	160	60	550	470	42	35	M30	1 ¹ / ₄	290	18	53,8	SNV290-F-L
	170	351	225	160	60	550	470	42	35	M30	1 ¹ / ₄	290	18	53,8	SNV290-F-L
	200	406	235	190	70	680	580	50	42	M36	1 ¹ / ₂	340	18	115	SNV340-F-L
	170	351	225	160	60	550	470	42	35	M30	1 ¹ / ₄	290	18	53,8	SNV290-F-L

medias ► <https://www.schaeffler.de/std/1E8D>

① Locating bearing; ② Non-locating bearing

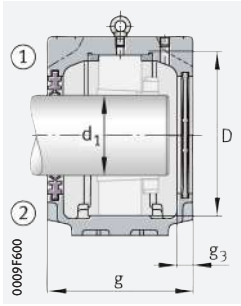

Double lip seal DH
Cover DKV

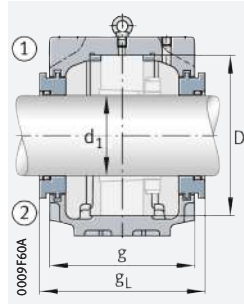

Labyrinth seal TSV

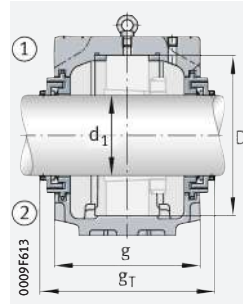

Taconite seal TCV

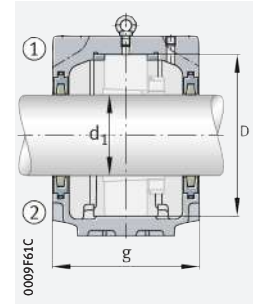

Felt seal FSV

Bearings and accessories

Bearing	Adapter sleeve	Locating ring 2 pieces	Double lip seal	Felt seal	Labyrinth seal	V ring seal		Taconite seal		Cover	
						g_L mm	g_v mm	g_T mm	g_T mm		
20226-K	H3026	FRM230/25	DH526	FSV526	TSV526	208,3	DHV526	199	TCV526	235	DKV230
22226..-K	H3126	FRM230/13	DH526	FSV526	TSV526	208,3	DHV526	199	TCV526	235	DKV230
22326..-K	H2326	FRM280/5	DH526	FSV526	TSV526	223,3	DHV526	214	TCV526	250	DKV230
23226..-K	H2326	FRM230/5	DH526	FSV526	TSV526	208,3	DHV526	199	TCV526	235	DKV230
20228-K	H3028	FRM250/28	DH528	FSV528	TSV528	218,3	DHV528	209	TCV528	245	DKV250
22228..-K	H3128	FRM250/15	DH528	FSV528	TSV528	218,3	DHV528	209	TCV528	245	DKV250
22328..-K	H2328	FRM300/5	DH528	FSV528	TSV528	233,3	DHV528	224	TCV528	260	DKV250
23228..-K	H2328	FRM250/5	DH528	FSV528	TSV528	218,3	DHV528	209	TCV528	245	DKV250
20230-K	H3030	FRM270/30,5	DH530	FSV530	TSV530	233,3	DHV530	224	TCV530	260	DKV270
22230..-K	H3130	FRM270/16,5	DH530	FSV530	TSV530	233,3	DHV530	224	TCV530	260	DKV270
22330..-K	H2330	FRM320/5	DH530	FSV530	TSV530	243,3	DHV530	234	TCV530	270	DKV270
23230..-K	H2330	FRM270/5	DH530	FSV530	TSV530	233,3	DHV530	224	TCV530	260	DKV270
20232-K	H3032(-HG)	FRM290/33	DH532	FSV532	TSV532	243,3	DHV532	234	TCV532	270	DKV290
22232..-K	H3132(-HG)	FRM290/17	DH532	FSV532	TSV532	243,3	DHV532	234	TCV532	270	DKV290
22332-K	H2332(-HG)	FRM340/5	DH532	FSV532	TSV532	253,3	DHV532	244	TCV532	298	DKV290
23232..-K	H2332(-HG)	FRM290/5	DH532	FSV532	TSV532	243,3	DHV532	234	TCV532	270	DKV290





Plummer block housings

SNV, split
For bearings
with cylindrical bore,
metric shaft

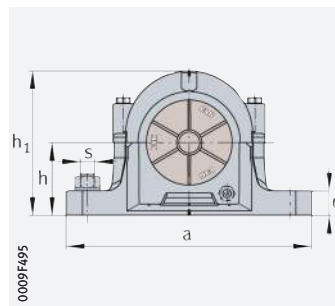
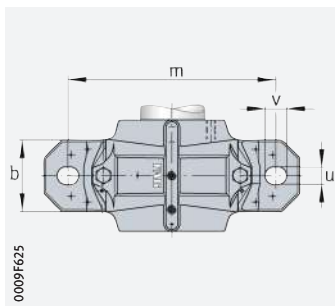

d = 20 – 35 mm

Shaft		Housing														Housing Designation ▶ 1592 2.10	
d	d ₂	Dimensions												D	g ₃		Mass m ≈ kg
		h	h ₁	g	b	c	a	m	v	u	s	mm	inch				
20	25	40	75	70	46	19	165	130	20	15	M12	1/2	52	10,5	1,3	SNV052-F-L	
	25	40	75	70	46	19	165	130	20	15	M12	1/2	52	10,5	1,3	SNV052-F-L	
	25	40	75	70	46	19	165	130	20	15	M12	1/2	52	10,5	1,3	SNV052-F-L	
	25	40	75	70	46	19	165	130	20	15	M12	1/2	52	10,5	1,3	SNV052-F-L	
25	30	40	75	70	46	19	165	130	20	15	M12	1/2	52	10,5	1,3	SNV052-F-L	
	30	50	91	75	52	22	185	150	20	15	M12	1/2	62	10,5	1,9	SNV062-F-L	
	30	40	75	70	46	19	165	130	20	15	M12	1/2	52	10,5	1,3	SNV052-F-L	
	30	50	91	75	52	22	185	150	20	15	M12	1/2	62	10,5	1,9	SNV062-F-L	
	30	40	75	70	46	19	165	130	20	15	M12	1/2	52	10,5	1,3	SNV052-F-L	
	30	50	91	75	52	22	185	150	20	15	M12	1/2	62	10,5	1,9	SNV062-F-L	
	30	50	91	75	52	22	185	150	20	15	M12	1/2	62	10,5	1,9	SNV062-F-L	
	30	40	75	70	46	19	165	130	20	15	M12	1/2	52	10,5	1,3	SNV052-F-L	
30	35	50	91	75	52	22	185	150	20	15	M12	1/2	62	10,5	1,9	SNV062-F-L	
	35	50	97	80	52	22	185	150	20	15	M12	1/2	72	10,5	2	SNV072-F-L	
	35	50	91	75	52	22	185	150	20	15	M12	1/2	62	10,5	1,9	SNV062-F-L	
	35	50	97	80	52	22	185	150	20	15	M12	1/2	72	10,5	2	SNV072-F-L	
	35	50	91	75	52	22	185	150	20	15	M12	1/2	62	10,5	1,9	SNV062-F-L	
	35	50	97	80	52	22	185	150	20	15	M12	1/2	72	10,5	2	SNV072-F-L	
	35	50	97	80	52	22	185	150	20	15	M12	1/2	72	10,5	2	SNV072-F-L	
	35	50	91	75	52	22	185	150	20	15	M12	1/2	62	10,5	1,9	SNV062-F-L	
35	45	50	97	80	52	22	185	150	20	15	M12	1/2	72	10,5	2	SNV072-F-L	
	45	60	112	85	60	25	205	170	20	15	M12	1/2	80	10,5	2,9	SNV080-F-L	
	45	50	97	80	52	22	185	150	20	15	M12	1/2	72	10,5	2	SNV072-F-L	
	45	60	112	85	60	25	205	170	20	15	M12	1/2	80	10,5	2,9	SNV080-F-L	
	45	50	97	80	52	22	185	150	20	15	M12	1/2	72	10,5	2	SNV072-F-L	
	45	60	112	85	60	25	205	170	20	15	M12	1/2	80	10,5	2,9	SNV080-F-L	
	45	60	112	85	60	25	205	170	20	15	M12	1/2	80	10,5	2,9	SNV080-F-L	
	45	50	97	80	52	22	185	150	20	15	M12	1/2	72	10,5	2	SNV072-F-L	

medias ▶ <https://www.schaeffler.de/std/1E8E>

① Locating bearing; ② Non-locating bearing

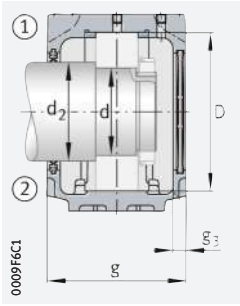

Double lip seal DH
Cover DKV

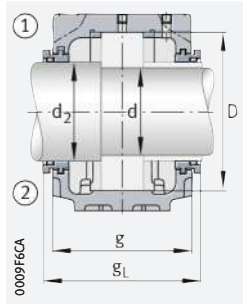

Labyrinth seal TSV

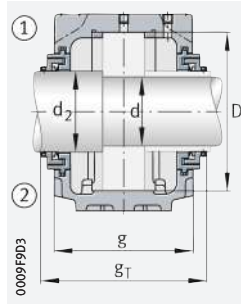

Taconite seal TCV

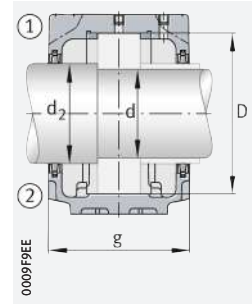

Felt seal FSV

Bearings and accessories

Bearing	Lock-nut	Tab washer	Locating ring 2 pieces	Double lip seal	Felt seal	Labyrinth seal		V ring seal		Taconite seal		Cover
						gL mm		gV mm		gT mm		
1304	KM4	MB4	FRM52/6	DH304	-	TSV304	95	DHV304	76	-	-	DKV052
2304	KM4	MB4	FRM52/3	DH304	-	TSV304	95	DHV304	76	-	-	DKV052
20304	KM4	MB4	FRM52/6	DH304	-	TSV304	95	DHV304	76	-	-	DKV052
21304	KM4	MB4	FRM52/6	DH304	-	TSV304	95	DHV304	76	-	-	DKV052
1205	KM5	MB5	FRM52/6	DH205	-	TSV205	95	-	-	-	-	DKV052
1305	KM5	MB5	FRM62/6,5	DH305	FSV305	TSV305	100	DHV305	81	-	-	DKV062
2205	KM5	MB5	FRM52/4,5	DH205	-	TSV205	95	-	-	-	-	DKV052
2305	KM5	MB5	FRM62/3	DH305	FSV305	TSV305	100	DHV305	81	-	-	DKV062
20205	KM5	MB5	FRM52/6	DH205	-	TSV205	95	-	-	-	-	DKV052
20305	KM5	MB5	FRM62/6,5	DH305	FSV305	TSV305	100	DHV305	81	-	-	DKV062
21305	KM5	MB5	FRM62/6,5	DH305	FSV305	TSV305	100	DHV305	81	-	-	DKV062
22205	KM5	MB5	FRM52/4,5	DH205	-	TSV205	95	-	-	-	-	DKV052
1206	KM6	MB6	FRM62/7	DH206	-	TSV206	100	-	-	-	-	DKV062
1306	KM6	MB6	FRM72/7	DH306	FSV306	TSV306	93	DHV306	86	-	-	DKV072
2206	KM6	MB6	FRM62/5	DH206	-	TSV206	100	-	-	-	-	DKV062
2306	KM6	MB6	FRM72/3	DH306	FSV306	TSV306	93	DHV306	86	-	-	DKV072
20206	KM6	MB6	FRM62/7	DH206	-	TSV206	100	-	-	-	-	DKV062
20306	KM6	MB6	FRM72/7	DH306	FSV306	TSV306	93	DHV306	86	-	-	DKV072
21306	KM6	MB6	FRM72/7	DH306	FSV306	TSV306	93	DHV306	86	-	-	DKV072
22206	KM6	MB6	FRM62/5	DH206	-	TSV206	100	-	-	-	-	DKV062
1207	KM7	MB7	FRM72/8	DH207	-	TSV207	107	-	-	-	-	DKV072
1307	KM7	MB7	FRM80/9	DH307	FSV307	TSV307	98	DHV307	93	-	-	DKV080
2207	KM7	MB7	FRM72/5	DH207	-	TSV207	107	-	-	-	-	DKV072
2307	KM7	MB7	FRM80/4	DH307	FSV307	TSV307	98	DHV307	93	-	-	DKV080
20207	KM7	MB7	FRM72/8	DH207	-	TSV207	107	-	-	-	-	DKV072
20307	KM7	MB7	FRM80/9	DH307	FSV307	TSV307	98	DHV307	93	-	-	DKV080
21307	KM7	MB7	FRM80/9	DH307	FSV307	TSV307	98	DHV307	93	-	-	DKV080
22207	KM7	MB7	FRM72/5	DH207	-	TSV207	107	-	-	-	-	DKV072





Plummer block housings

SNV, split
For bearings
with cylindrical bore,
metric shaft

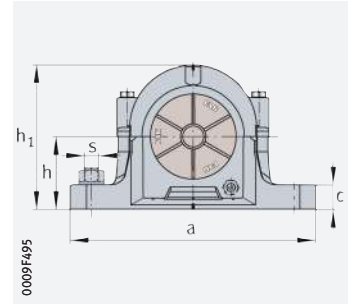
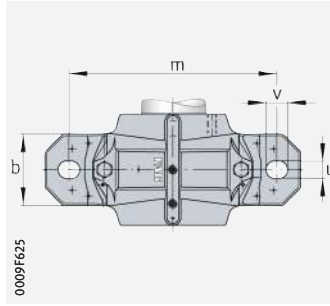

d = 40 – 50 mm

Shaft		Housing														Housing Designation ▶ 1592 2.10
d	d ₂	Dimensions												D	g ₃	
		h	h ₁	g	b	c	a	m	v	u	s					
											mm	inch				
40	50	60	112	85	60	25	205	170	20	15	M12	1/2	80	10,5	2,9	SNV080-F-L
	50	60	117	100	60	25	205	170	20	15	M12	1/2	90	12,5	3,1	SNV090-F-L
	50	60	112	85	60	25	205	170	20	15	M12	1/2	80	10,5	2,9	SNV080-F-L
	50	60	117	100	60	25	205	170	20	15	M12	1/2	90	12,5	3,1	SNV090-F-L
	50	60	112	85	60	25	205	170	20	15	M12	1/2	80	10,5	2,9	SNV080-F-L
	50	60	117	100	60	25	205	170	20	15	M12	1/2	90	12,5	3,1	SNV090-F-L
	50	60	117	100	60	25	205	170	20	15	M12	1/2	90	12,5	3,1	SNV090-F-L
	50	60	112	85	60	25	205	170	20	15	M12	1/2	80	10,5	2,9	SNV080-F-L
45	55	60	114	87	60	25	205	170	20	15	M12	1/2	85	12,5	2,8	SNV085-F-L
	55	70	133	105	70	28	255	210	23	18	M16	5/8	100	12,5	4,3	SNV100-F-L
	55	60	114	87	60	25	205	170	20	15	M12	1/2	85	12,5	2,8	SNV085-F-L
	55	70	133	105	70	28	255	210	23	18	M16	5/8	100	12,5	4,3	SNV100-F-L
	55	60	114	87	60	25	205	170	20	15	M12	1/2	85	12,5	2,8	SNV085-F-L
	55	70	133	105	70	28	255	210	23	18	M16	5/8	100	12,5	4,3	SNV100-F-L
	55	70	133	105	70	28	255	210	23	18	M16	5/8	100	12,5	4,3	SNV100-F-L
	55	60	114	87	60	25	205	170	20	15	M12	1/2	85	12,5	2,8	SNV085-F-L
50	60	60	117	100	60	25	205	170	20	15	M12	1/2	90	12,5	3,1	SNV090-F-L
	60	70	139	110	70	30	255	210	23	18	M16	5/8	110	12,5	4,9	SNV110-F-L
	60	60	117	100	60	25	205	170	20	15	M12	1/2	90	12,5	3,1	SNV090-F-L
	60	70	139	110	70	30	255	210	23	18	M16	5/8	110	12,5	4,9	SNV110-F-L
	60	60	117	100	60	25	205	170	20	15	M12	1/2	90	12,5	3,1	SNV090-F-L
	60	70	139	110	70	30	255	210	23	18	M16	5/8	110	12,5	4,9	SNV110-F-L
	60	70	139	110	70	30	255	210	23	18	M16	5/8	110	12,5	4,9	SNV110-F-L
	60	60	117	100	60	25	205	170	20	15	M12	1/2	90	12,5	3,1	SNV090-F-L
60	70	139	110	70	30	255	210	23	18	M16	5/8	110	12,5	4,9	SNV110-F-L	

medias ▶ <https://www.schaeffler.de/std/1E8F>

① Locating bearing; ② Non-locating bearing

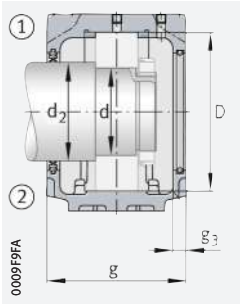

Double lip seal DH
Cover DKVT

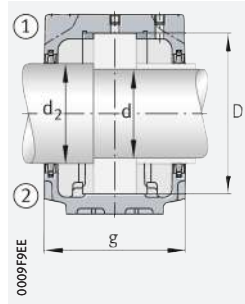

Felt seal FSV

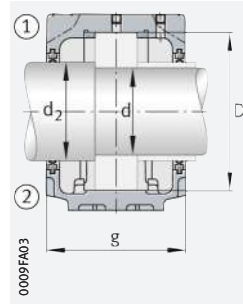

Double lip seal DH

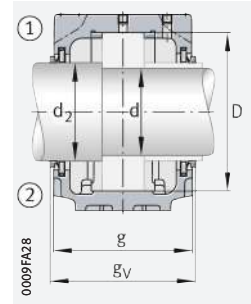

V ring seal DHV

Bearings and accessories

Bearing	Lock-nut	Tab washer	Locating ring 2 pieces	Double lip seal	Felt seal	Labyrinth seal		V ring seal		Taconite seal		Cover
						gL mm		gv mm		gT mm		
1208	KM8	MB8	FRM80/10,5	DH208	FSV208	TSV208	98	DHV208	93	-	-	DKV080
1308	KM8	MB8	FRM90/9	DH308	FSV308	TSV308	114	DHV308	106	-	-	DKV090
2208	KM8	MB8	FRM80/8	DH208	FSV208	TSV208	98	DHV208	93	-	-	DKV080
2308	KM8	MB8	FRM90/4	DH308	FSV308	TSV308	114	DHV308	106	-	-	DKV090
20208	KM8	MB8	FRM80/10,5	DH208	FSV208	TSV208	98	DHV208	93	-	-	DKV080
20308	KM8	MB8	FRM90/9	DH308	FSV308	TSV308	114	DHV308	106	-	-	DKV090
21308	KM8	MB8	FRM90/9	DH308	FSV308	TSV308	114	DHV308	106	-	-	DKV090
22208	KM8	MB8	FRM80/8	DH208	FSV208	TSV208	98	DHV208	93	-	-	DKV080
22308	KM8	MB8	FRM90/4	DH308	FSV308	TSV308	114	DHV308	106	-	-	DKV090
1209	KM9	MB9	FRM85/6	DH209	FSV209	TSV209	101	DHV209	93	-	-	DKV085
1309	KM9	MB9	FRM100/9,5	DH309	FSV309	TSV309	119	DHV309	111	-	-	DKV100
2209	KM9	MB9	FRM85/4	DH209	FSV209	TSV209	101	DHV209	93	-	-	DKV085
2309	KM9	MB9	FRM100/4	DH309	FSV309	TSV309	119	DHV309	111	-	-	DKV100
20209	KM9	MB9	FRM85/6	DH209	FSV209	TSV209	101	DHV209	93	-	-	DKV085
20309	KM9	MB9	FRM100/9,5	DH309	FSV309	TSV309	119	DHV309	111	-	-	DKV100
21309	KM9	MB9	FRM100/9,5	DH309	FSV309	TSV309	119	DHV309	111	-	-	DKV100
22209	KM9	MB9	FRM85/4	DH209	FSV209	TSV209	101	DHV209	93	-	-	DKV085
22309	KM9	MB9	FRM100/4	DH309	FSV309	TSV309	119	DHV309	111	-	-	DKV100
1210	KM10	MB10	FRM90/10,5	DH210	FSV210	TSV210	114	DHV210	106	-	-	DKV090
1310	KM10	MB10	FRM110/10,5	DH310	FSV310	TSV310	124	DHV310	116	-	-	DKV110
2210	KM10	MB10	FRM90/9	DH210	FSV210	TSV210	114	DHV210	106	-	-	DKV090
2310	KM10	MB10	FRM110/4	DH310	FSV310	TSV310	124	DHV310	116	-	-	DKV110
20210	KM10	MB10	FRM90/10,5	DH210	FSV210	TSV210	114	DHV210	106	-	-	DKV090
20310	KM10	MB10	FRM110/10,5	DH310	FSV310	TSV310	124	DHV310	116	-	-	DKV110
21310	KM10	MB10	FRM110/10,5	DH310	FSV310	TSV310	124	DHV310	116	-	-	DKV110
22210	KM10	MB10	FRM90/9	DH210	FSV210	TSV210	114	DHV210	106	-	-	DKV090
22310	KM10	MB10	FRM110/4	DH310	FSV310	TSV310	124	DHV310	116	-	-	DKV110





Plummer block housings

SNV, split
For bearings
with cylindrical bore,
metric shaft

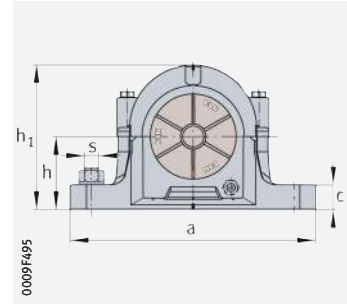
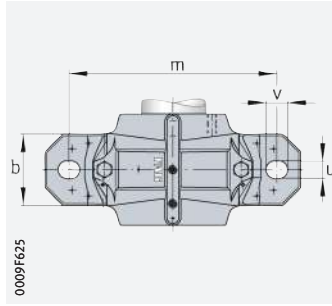

d = 55 – 65 mm

Shaft		Housing													Housing Designation ► 1592 2.10	
d	d ₂	Dimensions											D	g ₃		Mass m ≈ kg
		h	h ₁	g	b	c	a	m	v	u	s	mm				
55	65	70	133	105	70	28	255	210	23	18	M16	5/8	100	12,5	4,3	SNV100-F-L
	65	80	155	115	80	30	275	230	23	18	M16	5/8	120	12,5	6,1	SNV120-F-L
	65	70	133	105	70	28	255	210	23	18	M16	5/8	100	12,5	4,3	SNV100-F-L
	65	80	155	115	80	30	275	230	23	18	M16	5/8	120	12,5	6,1	SNV120-F-L
	65	70	133	105	70	28	255	210	23	18	M16	5/8	100	12,5	4,3	SNV100-F-L
	65	80	155	115	80	30	275	230	23	18	M16	5/8	120	12,5	6,1	SNV120-F-L
	65	80	155	115	80	30	275	230	23	18	M16	5/8	120	12,5	6,1	SNV120-F-L
	65	70	133	105	70	28	255	210	23	18	M16	5/8	100	12,5	4,3	SNV100-F-L
60	70	70	139	110	70	30	255	210	23	18	M16	5/8	110	12,5	4,9	SNV110-F-L
	70	80	161	120	80	30	280	230	23	18	M16	5/8	130	12,5	6,8	SNV130-F-L
	70	70	139	110	70	30	255	210	23	18	M16	5/8	110	12,5	4,9	SNV110-F-L
	70	80	161	120	80	30	280	230	23	18	M16	5/8	130	12,5	6,8	SNV130-F-L
	70	70	139	110	70	30	255	210	23	18	M16	5/8	110	12,5	4,9	SNV110-F-L
	70	80	161	120	80	30	280	230	23	18	M16	5/8	130	12,5	6,8	SNV130-F-L
	70	80	161	120	80	30	280	230	23	18	M16	5/8	130	12,5	6,8	SNV130-F-L
	70	70	139	110	70	30	255	210	23	18	M16	5/8	110	12,5	4,9	SNV110-F-L
65	75	80	155	115	80	30	275	230	23	18	M16	5/8	120	12,5	6,1	SNV120-F-L
	75	95	183	135	90	32	315	260	27	22	M20	3/4	140	15	9,3	SNV140-F-L
	75	80	155	115	80	30	275	230	23	18	M16	5/8	120	12,5	6,1	SNV120-F-L
	75	95	183	135	90	32	315	260	27	22	M20	3/4	140	15	9,3	SNV140-F-L
	75	80	155	115	80	30	275	230	23	18	M16	5/8	120	12,5	6,1	SNV120-F-L
	75	95	183	135	90	32	315	260	27	22	M20	3/4	140	15	9,3	SNV140-F-L
	75	95	183	135	90	32	315	260	27	22	M20	3/4	140	15	9,3	SNV140-F-L
	75	80	155	115	80	30	275	230	23	18	M16	5/8	120	12,5	6,1	SNV120-F-L
75	95	183	135	90	32	315	260	27	22	M20	3/4	140	15	9,3	SNV140-F-L	

medias ► <https://www.schaeffler.de/std/1E90>

① Locating bearing; ② Non-locating bearing

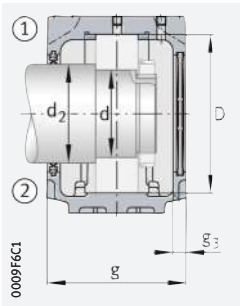

Double lip seal DH
Cover DKV

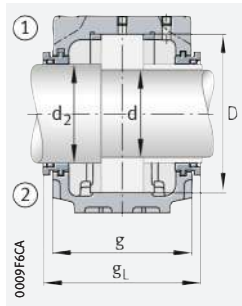

Labyrinth seal TSV

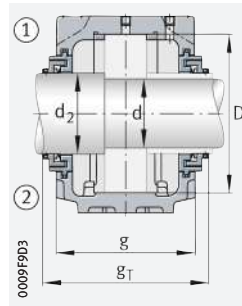

Taconite seal TCV

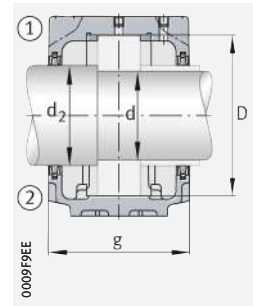

Felt seal FSV

Bearings and accessories

Bearing	Lock-nut	Tab washer	Locating ring 2 pieces	Double lip seal	Felt seal	Labyrinth seal		V ring seal		Taconite seal		Cover
						gL mm		gV mm		gT mm		
1211	KM11	MB11	FRM100/11,5	DH211	FSV211	TSV211	119	DHV211	111	-	-	DKV100
1311	KM11	MB11	FRM120/11	DH311	FSV311	TSV311	129	DHV311	121	-	-	DKV120
2211	KM11	MB11	FRM100/9,5	DH211	FSV211	TSV211	119	DHV211	111	-	-	DKV100
2311	KM11	MB11	FRM120/4	DH311	FSV311	TSV311	129	DHV311	121	-	-	DKV120
20211	KM11	MB11	FRM100/11,5	DH211	FSV211	TSV211	119	DHV211	111	-	-	DKV100
20311	KM11	MB11	FRM120/11	DH311	FSV311	TSV311	129	DHV311	121	-	-	DKV120
21311	KM11	MB11	FRM120/11	DH311	FSV311	TSV311	129	DHV311	121	-	-	DKV120
22211	KM11	MB11	FRM100/9,5	DH211	FSV211	TSV211	119	DHV211	111	-	-	DKV100
22311	KM11	MB11	FRM120/4	DH311	FSV311	TSV311	129	DHV311	121	-	-	DKV120
1212	KM12	MB12	FRM110/13	DH212	FSV212	TSV212	124	DHV212	120	-	-	DKV110
1312	KM12	MB12	FRM130/12,5	DH312	FSV312	TSV312	134	DHV312	130	TCV312	158	DKV130
2212	KM12	MB12	FRM110/10	DH212	FSV212	TSV212	124	DHV212	120	-	-	DKV110
2312	KM12	MB12	FRM130/5	DH312	FSV312	TSV312	134	DHV312	130	TCV312	158	DKV130
20212	KM12	MB12	FRM110/13	DH212	FSV212	TSV212	124	DHV212	120	-	-	DKV110
20312	KM12	MB12	FRM130/12,5	DH312	FSV312	TSV312	134	DHV312	130	TCV312	158	DKV130
21312	KM12	MB12	FRM130/12,5	DH312	FSV312	TSV312	134	DHV312	130	TCV312	158	DKV130
22212	KM12	MB12	FRM110/10	DH212	FSV212	TSV212	124	DHV212	120	-	-	DKV110
22312	KM12	MB12	FRM130/5	DH312	FSV312	TSV312	134	DHV312	130	TCV312	158	DKV130
1213	KM13	MB13	FRM120/14	DH213	FSV213	TSV213	129	DHV213	125	-	-	DKV120
1313	KM13	MB13	FRM140/12,5	DH313	FSV313	TSV313	150,3	DHV313	142,5	TCV313	175,5	DKV140
2213	KM13	MB13	FRM120/10	DH213	FSV213	TSV213	129	DHV213	125	-	-	DKV120
2313	KM13	MB13	FRM140/5	DH313	FSV313	TSV313	150,3	DHV313	142,5	TCV313	175,5	DKV140
20213	KM13	MB13	FRM120/14	DH213	FSV213	TSV213	129	DHV213	125	-	-	DKV120
20313	KM13	MB13	FRM140/12,5	DH313	FSV313	TSV313	150,3	DHV313	142,5	TCV313	175,5	DKV140
21313	KM13	MB13	FRM140/12,5	DH313	FSV313	TSV313	150,3	DHV313	142,5	TCV313	175,5	DKV140
22213	KM13	MB13	FRM120/10	DH213	FSV213	TSV213	129	DHV213	125	-	-	DKV120
22313	KM13	MB13	FRM140/5	DH313	FSV313	TSV313	150,3	DHV313	142,5	TCV313	175,5	DKV140



Plummer block housings

SNV, split
For bearings
with cylindrical bore,
metric shaft

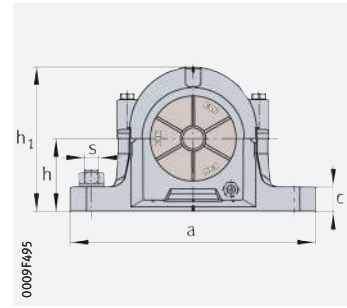
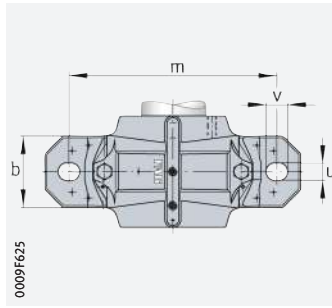

d = 70 – 80 mm

Shaft		Housing													Mass m	Housing Designation ▶ 1592 2.10
d	d ₂	Dimensions											≈ kg			
		h	h ₁	g	b	c	a	m	v	u	s		D	g ₃		
											mm	inch				
70	80	80	158	105	80	30	275	230	23	18	M16	5/8	125	15	6,5	SNV125-F-L
	80	95	189	140	90	32	320	260	27	22	M20	3/4	150	15	9,9	SNV150-F-L
	80	80	158	105	80	30	275	230	23	18	M16	5/8	125	15	6,5	SNV125-F-L
	80	95	189	140	90	32	320	260	27	22	M20	3/4	150	15	9,9	SNV150-F-L
	80	80	158	105	80	30	275	230	23	18	M16	5/8	125	15	6,5	SNV125-F-L
	80	95	189	140	90	32	320	260	27	22	M20	3/4	150	15	9,9	SNV150-F-L
	80	95	189	140	90	32	320	260	27	22	M20	3/4	150	15	9,9	SNV150-F-L
	80	80	158	105	80	30	275	230	23	18	M16	5/8	125	15	6,5	SNV125-F-L
75	85	80	161	120	80	30	280	230	23	18	M16	5/8	130	12,5	6,8	SNV130-F-L
	85	100	201	145	100	35	345	290	27	22	M20	3/4	160	15	12,8	SNV160-F-L
	85	80	161	120	80	30	280	230	23	18	M16	5/8	130	12,5	6,8	SNV130-F-L
	85	100	201	145	100	35	345	290	27	22	M20	3/4	160	15	12,8	SNV160-F-L
	85	80	161	120	80	30	280	230	23	18	M16	5/8	130	12,5	6,8	SNV130-F-L
	85	100	201	145	100	35	345	290	27	22	M20	3/4	160	15	12,8	SNV160-F-L
	85	100	201	145	100	35	345	290	27	22	M20	3/4	160	15	12,8	SNV160-F-L
	85	80	161	120	80	30	280	230	23	18	M16	5/8	130	12,5	6,8	SNV130-F-L
80	90	95	183	135	90	32	315	260	27	22	M20	3/4	140	15	9,3	SNV140-F-L
	90	112	219	150	100	35	345	290	27	22	M20	3/4	170	16	14,4	SNV170-F-L
	90	95	183	135	90	32	315	260	27	22	M20	3/4	140	15	9,3	SNV140-F-L
	90	112	219	150	100	35	345	290	27	22	M20	3/4	170	16	14,4	SNV170-F-L
	90	95	183	135	90	32	315	260	27	22	M20	3/4	140	15	9,3	SNV140-F-L
	90	112	219	150	100	35	345	290	27	22	M20	3/4	170	16	14,4	SNV170-F-L
	90	112	219	150	100	35	345	290	27	22	M20	3/4	170	16	14,4	SNV170-F-L
	90	95	183	135	90	32	315	260	27	22	M20	3/4	140	15	9,3	SNV140-F-L
90	112	219	150	100	35	345	290	27	22	M20	3/4	170	16	14,4	SNV170-F-L	

medias ▶ <https://www.schaeffler.de/std/1E91>

① Locating bearing; ② Non-locating bearing

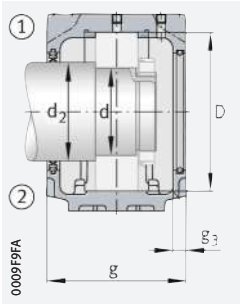

Double lip seal DH
Cover DKVT

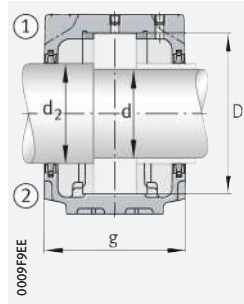

Felt seal FSV

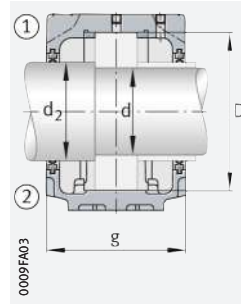

Double lip seal DH

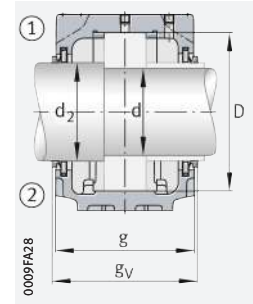

V ring seal DHV

Bearings and accessories

Bearing	Locknut	Tab washer	Locating ring 2 pieces	Double lip seal	Felt seal	Labyrinth seal		V ring seal		Taconite seal		Cover
						gL mm	gV mm	gT mm				
1214	KM14	MB14	FRM125/7,5	DH214	FSV214	TSV214	120,3	DHV214	110	TCV214	143	DKV150
1314	KM14	MB14	FRM150/13	DH214	FSV214	TSV214	155,3	DHV214	147,5	TCV214	180,5	DKV150
2214	KM14	MB14	FRM125/4	DH214	FSV214	TSV214	120,3	DHV214	110	TCV214	143	DKV150
2314	KM14	MB14	FRM150/5	DH214	FSV214	TSV214	155,3	DHV214	147,5	TCV214	180,5	DKV150
20214	KM14	MB14	FRM125/7,5	DH214	FSV214	TSV214	120,3	DHV214	110	TCV214	143	DKV150
20314	KM14	MB14	FRM150/13	DH214	FSV214	TSV214	155,3	DHV214	147,5	TCV214	180,5	DKV150
21314	KM14	MB14	FRM150/13	DH214	FSV214	TSV214	155,3	DHV214	147,5	TCV214	180,5	DKV150
22214	KM14	MB14	FRM125/4	DH214	FSV214	TSV214	120,3	DHV214	110	TCV214	143	DKV150
22314	KM14	MB14	FRM150/5	DH214	FSV214	TSV214	155,3	DHV214	147,5	TCV214	180,5	DKV150
1215	KM15	MB15	FRM130/15,5	DH215	FSV215	TSV215	134	DHV215	130	–	–	DKV130
1315	KM15	MB15	FRM160/14	DH315	FSV315	TSV315	160,3	DHV315	152,5	TCV315	185,5	DKV160
2215	KM15	MB15	FRM130/12,5	DH215	FSV215	TSV215	134	DHV215	130	–	–	DKV130
2315	KM15	MB15	FRM160/5	DH315	FSV315	TSV315	160,3	DHV315	152,5	TCV315	185,5	DKV160
20215	KM15	MB15	FRM130/15,5	DH215	FSV215	TSV215	134	DHV215	130	–	–	DKV130
20315	KM15	MB15	FRM160/14	DH315	FSV315	TSV315	160,3	DHV315	152,5	TCV315	185,5	DKV160
21315	KM15	MB15	FRM160/14	DH315	FSV315	TSV315	160,3	DHV315	152,5	TCV315	185,5	DKV160
22215	KM15	MB15	FRM130/12,5	DH215	FSV215	TSV215	134	DHV215	130	–	–	DKV130
22315	KM15	MB15	FRM160/5	DH315	FSV315	TSV315	160,3	DHV315	152,5	TCV315	185,5	DKV160
1216	KM16	MB16	FRM140/16	DH216	FSV216	TSV216	150,3	DHV216	142,5	–	–	DKV140
1316	KM16	MB16	FRM170/14,5	DH316	FSV316	TSV316	167,3	DHV316	157,5	TCV316	192,5	DKV170
2216	KM16	MB16	FRM140/12,5	DH216	FSV216	TSV216	150,3	DHV216	142,5	–	–	DKV140
2316	KM16	MB16	FRM170/5	DH316	FSV316	TSV316	167,3	DHV316	157,5	TCV316	192,5	DKV170
20216	KM16	MB16	FRM140/16	DH216	FSV216	TSV216	150,3	DHV216	142,5	–	–	DKV140
20316	KM16	MB16	FRM170/14,5	DH316	FSV316	TSV316	167,3	DHV316	157,5	TCV316	192,5	DKV170
21316	KM16	MB16	FRM170/14,5	DH316	FSV316	TSV316	167,3	DHV316	157,5	TCV316	192,5	DKV170
22216	KM16	MB16	FRM140/12,5	DH216	FSV216	TSV216	150,3	DHV216	142,5	–	–	DKV140
22316	KM16	MB16	FRM170/5	DH316	FSV316	TSV316	167,3	DHV316	157,5	TCV316	192,5	DKV170





Plummer block housings

SNV, split
For bearings
with cylindrical bore,
metric shaft

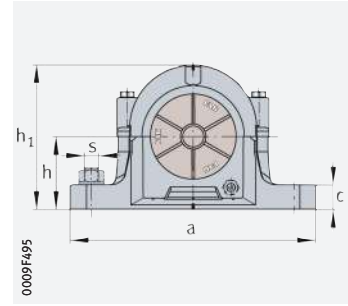
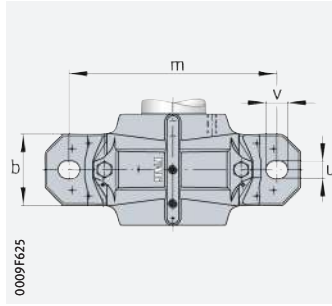

d = 85 – 95 mm

Shaft		Housing													Housing		
d	d ₂	Dimensions											D	g ₃	Mass m ≈ kg	Designation ▶ 1592 2.10	
		h	h ₁	g	b	c	a	m	v	u	s						
												mm	inch				
85	95	95	189	140	90	32	320	260	27	22	M20	3/4	150	15	9,9	SNV150-F-L	
	95	112	223	160	110	40	380	320	32	26	M24	7/8	180	16	17	SNV180-F-L	
	95	95	189	140	90	32	320	260	27	22	M20	3/4	150	15	9,9	SNV150-F-L	
	95	112	223	160	110	40	380	320	32	26	M24	7/8	180	16	17	SNV180-F-L	
	95	95	189	140	90	32	320	260	27	22	M20	3/4	150	15	9,9	SNV150-F-L	
	95	112	223	160	110	40	380	320	32	26	M24	7/8	180	16	17	SNV180-F-L	
	95	112	223	160	110	40	380	320	32	26	M24	7/8	180	16	17	SNV180-F-L	
	95	95	189	140	90	32	320	260	27	22	M20	3/4	150	15	9,9	SNV150-F-L	
90	100	100	201	145	100	35	345	290	27	22	M20	3/4	160	15	12,8	SNV160-F-L	
	105	112	229	155	110	40	380	320	32	26	M24	7/8	190	15	22	SNV190-F-L	
	100	100	201	145	100	35	345	290	27	22	M20	3/4	160	15	12,8	SNV160-F-L	
	105	112	229	155	110	40	380	320	32	26	M24	7/8	190	15	22	SNV190-F-L	
	100	100	201	145	100	35	345	290	27	22	M20	3/4	160	15	12,8	SNV160-F-L	
	105	112	229	155	110	40	380	320	32	26	M24	7/8	190	15	22	SNV190-F-L	
	105	112	229	155	110	40	380	320	32	26	M24	7/8	190	15	22	SNV190-F-L	
	100	100	201	145	100	35	345	290	27	22	M20	3/4	160	15	12,8	SNV160-F-L	
	105	112	229	155	110	40	380	320	32	26	M24	7/8	190	15	22	SNV190-F-L	
	100	100	201	145	100	35	345	290	27	22	M20	3/4	160	15	12,8	SNV160-F-L	
95	110	112	219	150	100	35	345	290	27	22	M20	3/4	170	16	14,4	SNV170-F-L	
	110	125	248	175	120	45	410	350	32	26	M24	7/8	200	16	21	SNV200-F-L	
	110	112	219	150	100	35	345	290	27	22	M20	3/4	170	16	14,4	SNV170-F-L	
	110	125	248	175	120	45	410	350	32	26	M24	7/8	200	16	21	SNV200-F-L	
	110	112	219	150	100	35	345	290	27	22	M20	3/4	170	16	14,4	SNV170-F-L	
	110	125	248	175	120	45	410	350	32	26	M24	7/8	200	16	21	SNV200-F-L	
	110	125	248	175	120	45	410	350	32	26	M24	7/8	200	16	21	SNV200-F-L	
	110	112	219	150	100	35	345	290	27	22	M20	3/4	170	16	14,4	SNV170-F-L	
	110	125	248	175	120	45	410	350	32	26	M24	7/8	200	16	21	SNV200-F-L	
	110	125	248	175	120	45	410	350	32	26	M24	7/8	200	16	21	SNV200-F-L	

medias ▶ <https://www.schaeffler.de/std/1E92>

① Locating bearing; ② Non-locating bearing

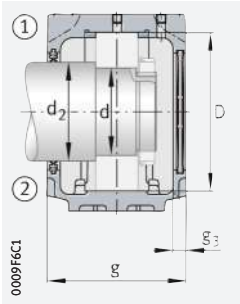

Double lip seal DH
Cover DKV

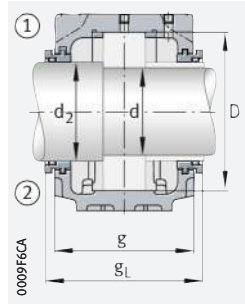

Labyrinth seal TSV

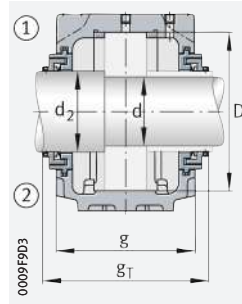

Taconite seal TCV

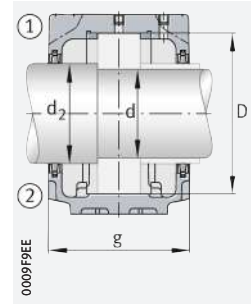

Felt seal FSV

Bearings and accessories

Bearing	Lock-nut	Tab washer	Locating ring 2 pieces	Double lip seal	Felt seal	Labyrinth seal		V ring seal		Taconite seal		Cover
						gL mm		gV mm		gT mm		
1217	KM17	MB17	FRM150/16,5	DH217	FSV217	TSV217	155,3	DHV217	137,5	-	-	DKV150
1317	KM17	MB17	FRM180/14,5	DH317	FSV317	TSV317	177,3	DHV317	167,5	TCV317	202,5	DKV180
2217	KM17	MB17	FRM150/12,5	DH217	FSV217	TSV217	155,3	DHV217	137,5	-	-	DKV150
2317	KM17	MB17	FRM180/5	DH317	FSV317	TSV317	177,3	DHV317	167,5	TCV317	202,5	DKV180
20217	KM17	MB17	FRM150/16,5	DH217	FSV217	TSV217	155,3	DHV217	137,5	-	-	DKV150
20317	KM17	MB17	FRM180/14,5	DH317	FSV317	TSV317	177,3	DHV317	167,5	TCV317	202,5	DKV180
21317	KM17	MB17	FRM180/14,5	DH317	FSV317	TSV317	177,3	DHV317	167,5	TCV317	202,5	DKV180
22217	KM17	MB17	FRM150/12,5	DH217	FSV217	TSV217	155,3	DHV217	137,5	-	-	DKV150
22317	KM17	MB17	FRM180/5	DH317	FSV317	TSV317	177,3	DHV317	167,5	TCV317	202,5	DKV180
1218	KM18	MB18	FRM160/17,5	DH218	FSV218	TSV218	160,3	DHV218	152,5	-	-	DKV160
1318	KM18	MB18	FRM190/15,5	DH318	FSV318	TSV318	170,3	DHV318	162,5	-	-	DKV160
2218	KM18	MB18	FRM160/12,5	DH218	FSV218	TSV218	160,3	DHV218	152,5	-	-	DKV160
2318	KM18	MB18	FRM190/5	DH318	FSV318	TSV318	170,3	DHV318	162,5	-	-	DKV160
20218	KM18	MB18	FRM160/17,5	DH218	FSV218	TSV218	160,3	DHV218	152,5	-	-	DKV160
20318	KM18	MB18	FRM190/15,5	DH318	FSV318	TSV318	170,3	DHV318	162,5	-	-	DKV160
21318	KM18	MB18	FRM190/15,5	DH318	FSV318	TSV318	170,3	DHV318	162,5	-	-	DKV160
22218	KM18	MB18	FRM160/12,5	DH218	FSV218	TSV218	160,3	DHV218	152,5	-	-	DKV160
22318	KM18	MB18	FRM190/5	DH318	FSV318	TSV318	170,3	DHV318	162,5	-	-	DKV160
23218	KM18	MB18	FRM160/6,3	DH218	FSV218	TSV218	160,3	DHV218	152,5	-	-	DKV160
1219	KM19	MB19	FRM170/18	DH219	FSV219	TSV219	167,3	DHV219	160,5	-	-	DKV170
1319	KM19	MB19	FRM200/17,5	DH319	FSV319	TSV319	192,3	DHV319	185,5	TCV319	217,5	DKV200
2219	KM19	MB19	FRM170/12,5	DH219	FSV219	TSV219	167,3	DHV219	160,5	-	-	DKV170
2319	KM19	MB19	FRM200/6,5	DH319	FSV319	TSV319	192,3	DHV319	185,5	TCV319	217,5	DKV200
20219	KM19	MB19	FRM170/18	DH219	FSV219	TSV219	167,3	DHV219	160,5	-	-	DKV170
20319	KM19	MB19	FRM200/17,5	DH319	FSV319	TSV319	192,3	DHV319	185,5	TCV319	217,5	DKV200
21319	KM19	MB19	FRM200/17,5	DH319	FSV319	TSV319	192,3	DHV319	185,5	TCV319	217,5	DKV200
22219	KM19	MB19	FRM170/12,5	DH219	FSV219	TSV219	167,3	DHV219	160,5	-	-	DKV170
22319	KM19	MB19	FRM200/6,5	DH319	FSV319	TSV319	192,3	DHV319	185,5	TCV319	217,5	DKV200





Plummer block housings

SNV, split
For bearings
with cylindrical bore,
metric shaft

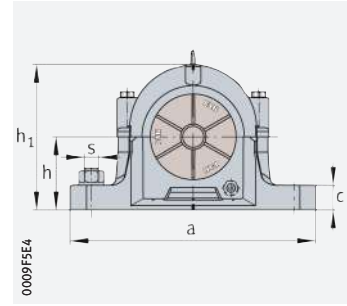
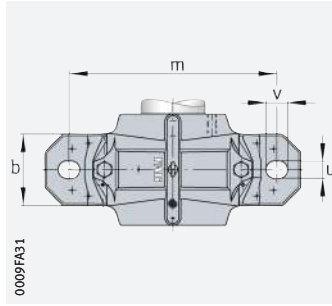

d = 100 – 120 mm

Shaft		Housing													Housing Designation ► 1592 2.10	
d	d ₂	Dimensions											D	g ₃		Mass m ≈ kg
		h	h ₁	g	b	c	a	m	v	u	s	mm				
100	115	112	223	160	110	40	380	320	32	26	M24	7/8	180	16	17	SNV180-F-L ¹⁾
	115	140	271	180	120	45	410	350	32	26	M24	7/8	215	16	24,5	SNV215-F-L
	115	112	223	160	110	40	380	320	32	26	M24	7/8	180	16	17	SNV180-F-L ¹⁾
	115	140	271	180	120	45	410	350	32	26	M24	7/8	215	16	24,5	SNV215-F-L
	115	112	223	160	110	40	380	320	32	26	M24	7/8	180	16	17	SNV180-F-L ¹⁾
	115	140	271	180	120	45	410	350	32	26	M24	7/8	215	16	24,5	SNV215-F-L
	115	140	271	180	120	45	410	350	32	26	M24	7/8	215	16	24,5	SNV215-F-L
	115	112	223	160	110	40	380	320	32	26	M24	7/8	180	16	17	SNV180-F-L ¹⁾
	115	140	271	180	120	45	410	350	32	26	M24	7/8	215	16	24,5	SNV215-F-L
110	125	125	248	175	120	45	410	350	32	26	M24	7/8	200	16	21	SNV200-F-L ¹⁾
	125	150	298	185	130	50	450	390	35	28	M24	1	240	18	32	SNV240-F-L
	125	125	248	175	120	45	410	350	32	26	M24	7/8	200	16	21	SNV200-F-L ¹⁾
	125	150	298	185	130	50	450	390	35	28	M24	1	240	18	32	SNV240-F-L
	125	125	248	175	120	45	410	350	32	26	M24	7/8	200	16	21	SNV200-F-L ¹⁾
	125	150	298	185	130	50	450	390	35	28	M24	1	240	18	32	SNV240-F-L
	125	150	298	185	130	50	450	390	35	28	M24	1	240	18	32	SNV240-F-L
	125	125	248	175	120	45	410	350	32	26	M24	7/8	200	16	21	SNV200-F-L ¹⁾
	125	150	298	185	130	50	450	390	35	28	M24	1	240	18	32	SNV240-F-L
120	135	140	271	180	120	45	410	350	32	26	M24	7/8	215	16	24,5	SNV215-F-L
	135	160	321	190	160	60	530	450	42	35	M30	1 1/4	260	18	48	SNV260-F-L
	135	140	271	180	120	45	410	350	32	26	M24	7/8	215	16	24,5	SNV215-F-L
	135	160	321	190	160	60	530	450	42	35	M30	1 1/4	260	18	48	SNV260-F-L
	135	140	271	180	120	45	410	350	32	26	M24	7/8	215	16	24,5	SNV215-F-L

medias ► <https://www.schaeffler.de/std/1E93>

① Locating bearing; ② Non-locating bearing

1) Housing without eye bolt.

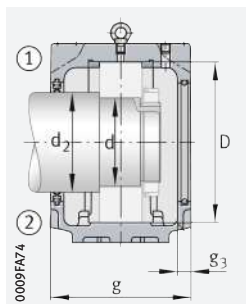

Double lip seal DH
Cover DKVT

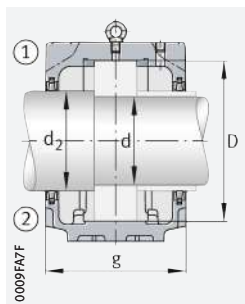

Felt seal FSV

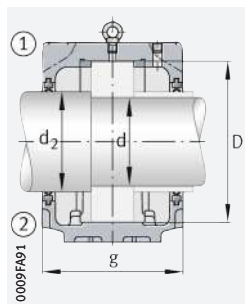

Double lip seal DH

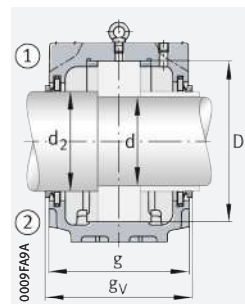

V ring seal DHV

Bearings and accessories

Bearing	Locknut	Tab washer	Locating ring 2 pieces	Double lip seal	Felt seal	Labyrinth seal		V ring seal		Taconite seal		Cover
						g _L mm			g _v mm		g _T mm	
1220	KM20	MB20	FRM180/18	DH220	FSV220	TSV220	177,3	DHV220	170,5	-	-	DKV180
1320	KM20	MB20	FRM215/19,5	DH320	FSV320	TSV320	197,3	DHV320	190,5	TCV320	226,5	DKV215
2220	KM20	MB20	FRM180/12	DH220	FSV220	TSV220	177,3	DHV220	170,5	-	-	DKV180
2320	KM20	MB20	FRM215/6,5	DH320	FSV320	TSV320	197,3	DHV320	190,5	TCV320	226,5	DKV215
20220	KM20	MB20	FRM180/18	DH220	FSV220	TSV220	177,3	DHV220	170,5	-	-	DKV180
20320	KM20	MB20	FRM215/19,5	DH320	FSV320	TSV320	197,3	DHV320	190,5	TCV320	226,5	DKV215
21320	KM20	MB20	FRM215/19,5	DH320	FSV320	TSV320	197,3	DHV320	190,5	TCV320	226,5	DKV215
22220	KM20	MB20	FRM180/12	DH220	FSV220	TSV220	177,3	DHV220	170,5	-	-	DKV180
22320	KM20	MB20	FRM215/6,5	DH320	FSV320	TSV320	197,3	DHV320	190,5	TCV320	226,5	DKV215
23220	KM20	MB20	FRM180/4,85	DH220	FSV220	TSV220	177,3	DHV220	170,5	-	-	DKV180
1222	KM22	MB22	FRM200/21	DH222	FSV222	TSV222	195,3	DHV222	185,5	-	-	DKV200
1322	KM22	MB22	FRM240/20	DH222	FSV222	TSV222	203,3	DHV222	193,5	-	-	DKV200
2222	KM22	MB22	FRM200/13,5	DH222	FSV222	TSV222	195,3	DHV222	185,5	-	-	DKV200
2322	KM22	MB22	FRM240/5	DH222	FSV222	TSV222	203,3	DHV222	193,5	-	-	DKV200
20222	KM22	MB22	FRM200/21	DH222	FSV222	TSV222	195,3	DHV222	185,5	-	-	DKV200
20322	KM22	MB22	FRM240/20	DH222	FSV222	TSV222	203,3	DHV222	193,5	-	-	DKV200
21322	KM22	MB22	FRM240/20	DH222	FSV222	TSV222	203,3	DHV222	193,5	-	-	DKV200
22222	KM22	MB22	FRM200/13,5	DH222	FSV222	TSV222	195,3	DHV222	185,5	-	-	DKV200
22322	KM22	MB22	FRM240/5	DH222	FSV222	TSV222	203,3	DHV222	193,5	-	-	DKV200
23222	KM22	MB22	FRM200/5,1	DH222	FSV222	TSV222	195,3	DHV222	185,5	-	-	DKV200
20224	KM24	MB24	FRM215/23	DH224	FSV224	TSV224	200,3	DHV224	190,5	-	-	DKV215
20324	KM24	MB24	FRM260/20,5	DH224	FSV224	TSV224	208,3	DHV224	198,5	-	-	DKV215
22224	KM24	MB24	FRM215/14	DH224	FSV224	TSV224	200,3	DHV224	190,5	-	-	DKV215
22324	KM24	MB24	FRM260/5	DH224	FSV224	TSV224	208,3	DHV224	198,5	-	-	DKV215
23224	KM24	MB24	FRM215/5	DH224	FSV224	TSV224	200,3	DHV224	190,5	-	-	DKV215





Plumber block housings

SNV, split
For bearings
with cylindrical bore,
metric shaft

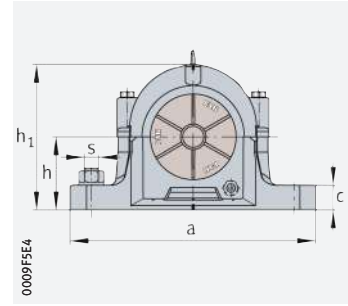
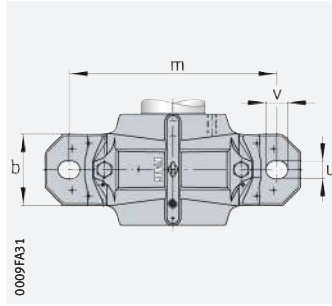

d = 130 – 160 mm

Shaft		Housing														Housing	
		Dimensions														Mass	Designation
d	d ₂	h	h ₁	g	b	c	a	m	v	u	s		D	g ₃	m	1592 2.10	
										mm		inch			≈ kg		
130	145	150	291	190	130	50	445	380	35	28	M24	1	230	18	30	SNV230-F-L	
	150	170	344	205	160	60	550	470	42	35	M30	1 1/4	280	18	55	SNV280-F-L	
	145	150	291	190	130	50	445	380	35	28	M24	1	230	18	30	SNV230-F-L	
	150	170	344	205	160	60	550	470	42	35	M30	1 1/4	280	18	55	SNV280-F-L	
	145	150	291	190	130	50	445	380	35	28	M24	1	230	18	30	SNV230-F-L	
140	155	150	304	200	150	50	500	420	42	35	M30	1 1/4	250	18	38	SNV250-F-L	
	160	180	366	215	170	65	620	520	42	35	M30	1 1/4	300	18	70	SNV300-F-L	
	155	150	304	200	150	50	500	420	42	35	M30	1 1/4	250	18	38	SNV250-F-L	
	160	180	366	215	170	65	620	520	42	35	M30	1 1/4	300	18	70	SNV300-F-L	
	155	150	304	200	150	50	500	420	42	35	M30	1 1/4	250	18	38	SNV250-F-L	
150	165	160	328	215	160	60	530	450	42	35	M30	1 1/4	270	18	45,5	SNV270-F-L	
	170	190	386	225	180	65	650	560	42	35	M30	1 1/4	320	18	95	SNV320-F-L	
	165	160	328	215	160	60	530	450	42	35	M30	1 1/4	270	18	45,5	SNV270-F-L	
	170	190	386	225	180	65	650	560	42	35	M30	1 1/4	320	18	95	SNV320-F-L	
	165	160	328	215	160	60	530	450	42	35	M30	1 1/4	270	18	45,5	SNV270-F-L	
160	175	170	351	225	160	60	550	470	42	35	M30	1 1/4	290	18	53,8	SNV290-F-L	
	175	170	351	225	160	60	550	470	42	35	M30	1 1/4	290	18	53,8	SNV290-F-L	
	180	200	406	235	190	70	680	580	50	42	M36	1 1/2	340	18	115	SNV340-F-L	
	175	170	351	225	160	60	550	470	42	35	M30	1 1/4	290	18	53,8	SNV290-F-L	

medias ► <https://www.schaeffler.de/std/1E94>

① Locating bearing; ② Non-locating bearing

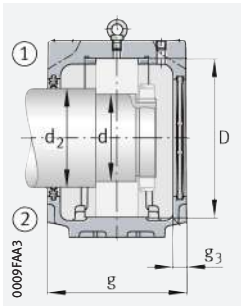

Double lip seal DH
Cover DKV

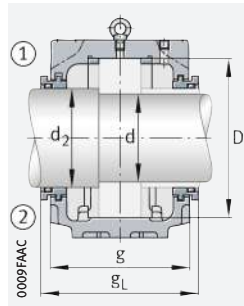

Labyrinth seal TSV

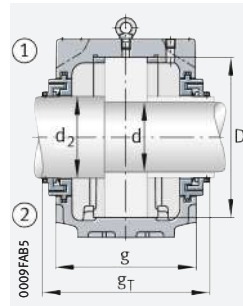

Taconite seal TCV

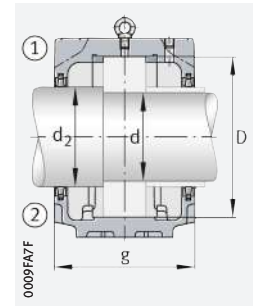

Felt seal FSV

Bearings and accessories

Bearing	Lock-nut	Tab washer	Locating ring 2 pieces	Double lip seal	Felt seal	Labyrinth seal		V ring seal		Taconite seal		Cover
						gL mm		gV mm		gT mm		
20226	KM26	MB26	FRM230/25	DH226	FSV226	TSV226	208,3	DHV226	198,5	-	-	DKV230
20326	KM26	MB26	FRM280/22,5	DH326	FSV326	TSV326	223,3	DHV326	213,5	-	-	DKV230
22226	KM26	MB26	FRM230/13	DH226	FSV226	TSV226	208,3	DHV226	198,5	-	-	DKV230
22326	KM26	MB26	FRM280/5	DH326	FSV326	TSV326	223,3	DHV326	213,5	-	-	DKV230
23226	KM26	MB26	FRM230/5	DH226	FSV226	TSV226	208,3	DHV226	198,5	-	-	DKV230
20228	KM28	MB28	FRM250/28	DH228	FSV228	TSV228	218,3	DHV228	211,5	-	-	DKV250
20328	KM28	MB28	FRM300/25	DH328	FSV328	TSV328	233,3	DHV328	226,5	-	-	DKV250
22228	KM28	MB28	FRM250/15	DH228	FSV228	TSV228	218,3	DHV228	211,5	-	-	DKV250
22328	KM28	MB28	FRM300/5	DH328	FSV328	TSV328	233,3	DHV328	226,5	-	-	DKV250
23228	KM28	MB28	FRM250/5	DH228	FSV228	TSV228	218,3	DHV228	211,5	-	-	DKV250
20230	KM30	MB30	FRM270/30,5	DH230	FSV230	TSV230	233,3	DHV230	228,5	-	-	DKV270
20330	KM30	MB30	FRM320/26,5	DH330	FSV330	TSV330	243,3	DHV330	236,5	-	-	DKV270
22230	KM30	MB30	FRM270/16,5	DH230	FSV230	TSV230	233,3	DHV230	228,5	-	-	DKV270
22330	KM30	MB30	FRM320/5	DH330	FSV330	TSV330	243,3	DHV330	236,5	-	-	DKV270
23230	KM30	MB30	FRM270/5	DH230	FSV230	TSV230	233,3	DHV230	228,5	-	-	DKV270
20232	KM32	MB32	FRM290/33	DH232	FSV232	TSV232	243,3	DHV232	236,5	-	-	DKV290
22232	KM32	MB32	FRM290/17	DH232	FSV232	TSV232	243,3	DHV232	236,5	-	-	DKV290
22332	KM32	MB32	FRM340/5	DH332	FSV332	TSV332	253,3	DHV332	246,5	-	-	DKV290
23232	KM32	MB32	FRM290/5	DH232	FSV232	TSV232	243,3	DHV232	236,5	-	-	DKV290



3 Split plummer block housings SNS



Split plummer block housings SNS:

- are designed in accordance with a modular concept and are highly versatile in application ▶ 1624|3.1
- are suitable for different bearing types and sizes with bore diameters from 115 mm to 530 mm ▶ 1627|3.2
- lead, as a result of their design, to optimised load distribution and thereby increase the rating life of the bearing by up to 50% ▶ 1624|☐ 1 and ▶ 1624|3.1
- give a reduction, due to the lower replacement frequency of the bearing fitted, in total costs over the running time.



Influence of housing design on the load distribution in the bearing

- ① Conventional plummer block housing with associated load distribution
- ② FAG plummer block housing SNS with associated load distribution

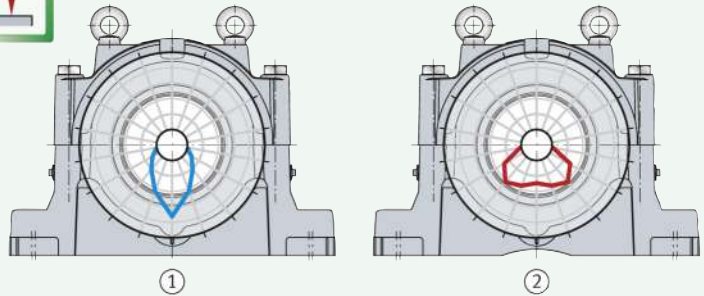

3.1 Housing design

Housings for aggressive environmental conditions

Split plummer block housings SNS are highly robust and therefore particularly suitable for aggressive environmental conditions such as those in mining applications ▶ 1624|☐ 2 and ▶ 1625|☐ 3.



Split plummer block housings SNS..-H and SNS..-Z

Housing design for labyrinth and taconite seal



0009F853



Split plummer block housings SNS...-B

Housing design for Bolt-on seal



Modular concept

☞ *The decisive factor is the outside diameter of the bearing*

The housings are designed in accordance with a modular concept. Each housing can be fitted with rolling bearings of various diameter and width series if they have the correct outside diameter for the housing.

☞ *Seals are matched to the shaft diameter*

Depending on their design, the bearings can be located either directly on the shaft or by means of an adapter sleeve. This gives different shaft diameters for the same bearing size. The spacings between the shaft and housing body are compensated by means of appropriately matched seals.

Longer bearing life

☞ *Bearing rating life up to 50% longer than with conventional plummer block housings*

In the case of plummer block housings SNS, the life of the spherical roller bearings fitted is up to 50% longer than in the case of conventional plummer block housings. The increase in life is dependent on the application, the load and the bearing design. Calculation of the bearing life is based on the calculation software BEARINX. The reason for the longer bearing life is the optimised load distribution in the bearing that is achieved as a result of the new housing design ► 1624 | 1.

☞ *Conventional plummer block housings: unfavourable load distribution in the bearing*

Conventional plummer block housings are designed such that the bearing load is introduced into the housing locating face by means of a support area directly below the bearing. If loading is in the main load direction, namely with an orientation vertical to the housing locating face, an unfavourable load distribution occurs in the bearing. Due to the narrow load zone, the load is distributed over only a small number of rolling elements, leading to a particularly high load maximum on the roller in the apex position.

☞ *Plummer block housings SNS: optimised load distribution*

In the case of plummer block housings SNS, a material recess below the bearing distributes the support area over two symmetrically arranged support faces. This leads to a significant improvement in the load distribution in the bearing. The load zone is wider and the load is distributed more uniformly over several rolling elements. The maximum is now present on the two neighbouring rollers of the roller in the apex position and is reduced. This results in a significant increase in the fatigue life of the rolling bearings.



Advantages of detailed design

A large number of details in the housing design that are systematically matched to practical application allows a particularly flexible and economical usage of plummer block housings SNS ▶ 1626 | 4.



Advantages of detailed design

- ① Lubrication hole with long axial lubrication groove
- ② Pilot hole at predefined position for condition monitoring
- ③ Grease outlet holes
- ④ Indentations indicating shaft and bearing centres
- ⑤ Inclined run-off areas
- ⑥ Machined locating faces
- ⑦ Prepared mounting points for condition monitoring
- ⑧ Marking of housing halves
- ⑨ Dismounting notches
- ⑩ Overhang of upper housing section

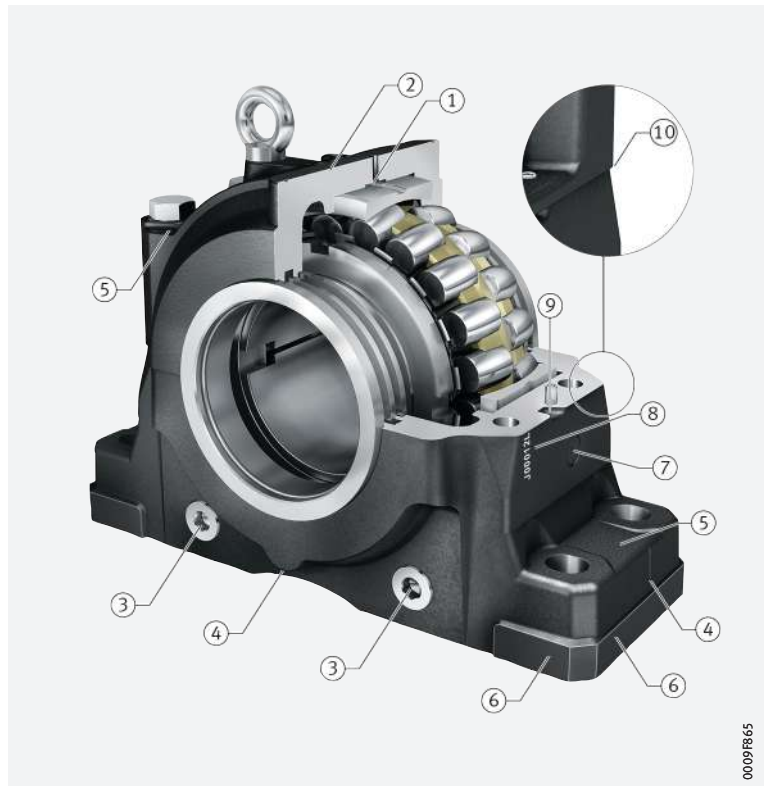

🔍 **Lubrication hole with long axial lubrication groove**

A lubrication hole with a long axial lubrication groove in the upper housing section ensures supply of lubricant irrespective of bearing position to all bearing series that can be fitted. Suitable lubrication nipples are included in the scope of delivery.

🔍 **Grease outlet holes**

Grease outlet holes in the lower housing section allow the escape of used and superfluous grease during relubrication.

🔍 **Indentations**

Indentations in the lower housing section indicate the shaft and bearing centres in the housing. This allows rapid alignment and reduces mounting time.

🔍 **Inclined run-off areas**

Inclined run-off areas on the upper and lower housing section promote the removal of fluids and reduce deposits of contamination. This leads to reduced cleaning work and a lower risk of corrosion.

🔍 **Machined locating faces**

Machined locating faces on the lower housing section allow precise alignment of the housing. When the housing is painted, the locating faces are also provided with a universal paint coating. Since the locating faces are raised, strips can be used as an alignment aid. One-off alignment is sufficient to allow rapid interchange of the housing when necessary.

🔍 **Prepared mounting points for condition monitoring**

In order to allow the uncomplicated use of condition monitoring, the lower housing section has a connection facility on both sides for condition monitoring systems. Due to the thread M6 and a flattened area of diameter 26 mm, it is possible to directly connect FAG SmartCheck, a modular online measuring system for machine monitoring. Alternatively, other vibration sensors can also be connected.

If neither of the two connection points is accessible as a result of the adjacent construction, a further suitable connection point on the upper section is indicated by a cast-in pilot hole.

FAG SmartCheck must be ordered separately. Detailed information
 ►  TPI 214 or ► <https://www.schaeffler.de/std/1B73>.

 **Marking of housing halves**

The upper housing section and lower housing section are matched to each other and must not be transposed with other housing halves. The serial numbering on both halves of the housing ensure their correction allocation. Furthermore, the serial numbering allows traceability and simplified documentation.

 **Dismounting notches**

Recessed dismounting notches on the interface of the housing halves make it easier to remove the upper housing section.

 **Overhang of upper housing section**

The overhang of the upper housing section prevents the collection of fluids and contaminants at the interface of the two housing halves. This leads to reduced cleaning work and a lower risk of corrosion.

3.2 Suitable bearings

 **Shaft diameters from 115 mm to 530 mm and from 4⁷/₁₆ inch to 19¹/₂ inch**

Split plummer block housings SNS are suitable for fitting with spherical roller bearings or toroidal roller bearings with a tapered or cylindrical bore
 ► 1627  1. The range of shaft diameters is 115 mm to 530 mm and 4⁷/₁₆ inch to 19¹/₂ inch.

 **1 Bearing types and sizes**

Bearing type	Size
Spherical roller bearings	
■ with tapered bore and adapter sleeve	22232...K to 22272...K 22326...K to 22356...K 23036-K to 230/530...-K 23134...-K to 23196...-K 23232...-K to 23288...-K
■ with cylindrical bore	22232 to 22272 22326 to 22356 23036 to 230/530 23134 to 23196 23232 to 23288 24036 to 240/530
■ split	230SM160 to 230SM410 230S.607 to 230S.1608 231SM150 to 231SM410 231S.515 to 231S.1500 232SM260 to 232SM340 232S.1200 to 232S.1308
Toroidal roller bearings	
■ with tapered bore and adapter sleeve	C2232...-K to C2244...-K C2326...-K to C2356...-K C3036-K to C30/530...-K C3134...-K to C3196...-K C3232...-K to C3288...-K
■ with cylindrical bore	C2232 to C2244 C2326 to C2356 C3036 to C30/530 C3134 to C3196 C3232 to C3288 C4036 to C40/530



 **Split spherical roller bearings**

Unsplit spherical roller bearings with an adapter sleeve can be replaced by split spherical roller bearings ► 1627  1. This gives a considerable reduction in the work associated with bearing replacement in numerous applications.



In order to ensure selection of the correct combination of housing and bearing when using split bearings, please contact Schaeffler.



The range of split spherical roller bearings is described in detail in a separate publication ►  TPI 250.

Allocation of bearing and housing series

On the basis of the modular concept, one or more series of plummer block housings SNS are suitable for each series of spherical roller bearings
 ▶ 1628 | 2 to ▶ 1628 | 4.

2
 Plummer block housings SNS for spherical roller bearings with tapered bore and adapter sleeve

● = suitable

Bearing Series	Plummer block housing											
	SNS2264		SNS30		SNS31			SNS32		SNS40		
	Suffixes											
	H	Z	H	Z	H	Z	B	H	Z	H	Z	
222..-K	●	-	●	-	●	-	-	-	-	-	-	
223..-K	-	-	●	-	●	-	-	-	-	-	-	
230..-K	-	-	●	-	-	-	-	-	-	-	-	
231..-K	-	-	-	-	●	-	●	-	-	-	-	
232..-K	-	-	●	-	-	-	-	●	-	-	-	

3
 Plummer block housings SNS for spherical roller bearings with cylindrical bore

● = suitable

Bearing Series	Plummer block housing											
	SNS2264		SNS30		SNS31			SNS32		SNS40		
	Suffixes											
	H	Z	H	Z	H	Z	B	H	Z	H	Z	
222	-	●	●	-	●	●	-	-	-	-	-	
223	-	-	●	-	●	-	-	-	-	-	-	
230	-	-	●	●	-	-	-	-	-	-	-	
231	-	-	-	-	●	●	-	-	-	-	-	
232	-	-	●	-	-	-	-	-	●	-	-	
240	-	-	●	●	-	-	-	-	-	-	●	

4
 Plummer block housings SNS for split spherical roller bearings

● = suitable

Bearing Series	Plummer block housing											
	SNS2264		SNS30		SNS31			SNS32		SNS40		
	Suffixes											
	H	Z	H	Z	H	Z	B	H	Z	H	Z	
230S	-	-	●	-	-	-	-	-	-	-	-	
231S	-	-	-	-	●	-	●	-	-	-	-	
232S	-	-	-	-	-	-	-	●	-	-	-	

3.3 Materials, corrosion protection

Material

The housing bodies are made from spheroidal graphite cast iron GJS-400-15 (suffix D).

Corrosion protection

All outer surfaces not machined by chip-forming methods and the locating surfaces on the lower housing section have a universal paint coating (colour RAL 7016, anthracite grey). The coating can be finished using all synthetic resin, polyurethane, acrylic, epoxy resin, chlorinated rubber, nitrocellulose and acid-hardening hammer tone finishes.

Inner and outer surfaces machined by chip-forming methods are provided with anti-corrosion protection that can be easily removed.

It is recommended that only volatile solvents and lint-free cloths should be used.

3.4 Locating and non-locating bearings



Locating bearing arrangement by means of locating rings

The bearing seats in the housing are machined such that the bearings are movable and can thus function as non-locating bearings. Locating bearing arrangements can be achieved by the insertion of locating rings NFR on both sides of the bearing outer ring. Depending on the combination of housing and bearing, 2, 4 or 6 locating rings will be required

▶ 1650 | . Locating rings must be ordered separately.

3.5 Load carrying capacity

🔑 Guide values

Guide values are given for the rupture load of plummer block housings SNS and the maximum load carrying capacity of connecting screws for the upper and lower housing sections, ▶ 1629 |  5 and ▶ 1630 |  5. The guide values are valid for purely static loading. The guide values only apply if the flatness of the mounting surface in accordance with DIN EN ISO 1101 corresponds to the tolerance grade IT7 in accordance with DIN EN ISO 286-1 (measured across the diagonal). A precondition for supporting loads is that the housing base surface is completely and rigidly supported.

🔑 Safety factors

When determining the permissible static load, safety factors must be applied. For general machine building, the safety factor 6 relative to the housing rupture load is normally applied. Based on the precise calculation of the housing rupture loads using the Finite Element method and the use, as standard, of spheroidal graphite cast iron as the housing material, the safety factor 5 is sufficient for plummer block housings SNS. A safety factor is not required for the values given for the load carrying capacity of the connecting screws.



If the housing is subjected to axial load, the permissible axial load of the bearing fitted must be taken into consideration. If the bearing is located on the shaft using an adapter sleeve, the axial retaining force of the bearing and adapter sleeve must also be taken into consideration. If the load direction is between 55° and 120° or axial load is present, we recommend that the housings should be secured in the load direction by means of stops.



Load directions F for the guide values for the housing rupture load and the maximum load carrying capacity of the connecting screws

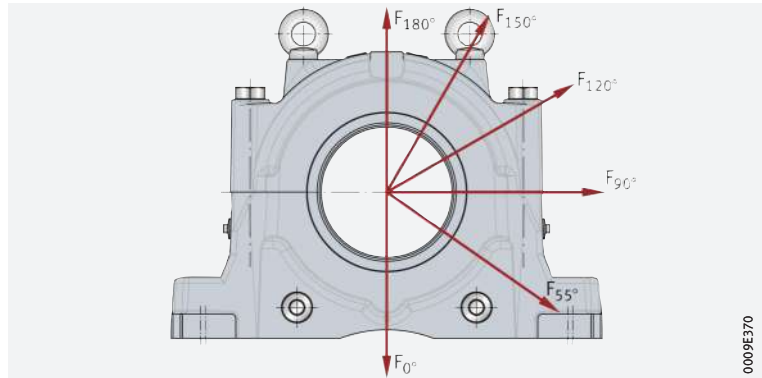



Guide values for housing rupture load and maximum load carrying capacity of connecting screws. Tightening torques

Housing designation					Housing rupture loads ¹⁾ in load direction F	
SNS22	SNS30	SNS31	SNS32	SNS40	0° kN	55° kN
–	SNS3036	SNS3134	–	–	4 050	4 540
–	SNS3038	SNS3136	–	–	4 400	4 940
–	SNS3040	SNS3138	SNS3234	–	4 880	5 480
–	–	–	SNS3236	–	4 880	5 480
–	SNS3044	SNS3140	SNS3238	–	5 800	6 500
–	SNS3048	SNS3144	SNS3240	–	6 240	7 560
–	SNS3052	SNS3148	–	–	7 330	8 550
–	–	–	SNS3244	–	7 330	8 550
–	SNS3056	SNS3152	–	–	8 740	9 810
–	–	–	SNS3248	–	8 740	9 810
–	SNS3060	SNS3156	–	–	9 200	10 320
–	SNS3064	SNS3160	–	–	10 150	11 390
–	–	–	SNS3252	–	10 150	11 390
–	–	–	SNS3256	–	10 150	11 390
–	SNS3068	SNS3164	–	–	11 410	12 810
–	SNS3072	–	–	–	11 410	12 810
–	–	–	SNS3260	–	11 410	12 810
SNS2264	SNS3076	SNS3168	–	SNS4076	13 300	14 930
–	–	–	SNS3264	–	13 300	14 930
–	SNS3080	SNS3172	–	–	14 740	16 540
–	–	–	–	SNS4080	14 740	16 540
–	SNS3084	SNS3176	–	–	15 940	17 890
–	–	–	SNS3268	–	15 940	17 890
–	–	–	–	SNS4084	15 940	17 890
–	SNS3088	SNS3180	–	–	18 490	20 750
–	–	–	SNS3272	–	18 490	20 750
–	–	–	–	SNS4088	18 490	20 750
–	SNS3092	SNS3184	–	SNS4092	20 180	22 650
–	SNS3096	–	–	SNS4096	20 180	22 650
–	–	–	SNS3276	–	20 180	22 650
–	SNS30/500	SNS3188	–	–	21 940	24 620
–	–	–	SNS3280	–	21 940	24 620
–	–	–	–	SNS40/500	21 940	24 620
–	–	SNS3192	–	–	24 150	27 100
–	–	–	SNS3284	–	24 150	27 100
–	SNS30/530	SNS3196	–	SNS40/530	26 080	29 270
–	–	–	SNS3288	–	26 080	29 270

¹⁾ For housings made from spheroidal graphite cast iron GJS-400-15 (suffix D).

²⁾ Maximum load carrying capacity in load direction F, where there is still contact at the parting line between the upper and lower housing sections.

					Connecting screws					
					Screws to DIN EN ISO 4014 Grade 8.8	Tightening torque Nm	Maximum load carrying capacity in load direction F ²⁾			
90° kN	120° kN	150° kN	180° kN	axial kN			90° kN	120° kN	150° kN	180° kN
3 040	1 650	1 190	1 220	1 170	M24	559	1 380	760	618	725
3 300	1 800	1 300	1 330	1 270	M24	559	1 370	760	615	723
3 660	1 990	1 440	1 470	1 410	M24	559	1 500	830	670	790
3 660	1 990	1 440	1 470	1 410	M24	559	1 500	830	670	790
4 350	2 370	1 700	1 750	1 670	M24	559	1 510	836	677	796
5 070	2 880	2 360	2 380	1 880	M24	559	1 484	820	664	781
5 720	3 190	2 470	2 510	2 080	M30	1 118	2 380	1 315	1 065	1 252
5 720	3 190	2 470	2 510	1 880	M30	1 118	2 380	1 315	1 065	1 252
6 550	3 570	2 580	2 640	2 520	M30	1 118	2 372	1 310	1 061	1 250
6 550	3 570	2 580	2 640	1 410	M30	1 118	2 372	1 310	1 061	1 250
6 900	3 760	2 710	2 780	2 652	M30	1 118	2 330	1 290	1 040	1 230
7 620	4 150	3 000	3 070	2 810	M30	1 118	2 220	1 230	990	1 170
7 620	4 150	3 000	3 070	2 230	M30	1 118	2 220	1 230	990	1 170
7 620	4 150	3 000	3 070	2 230	M30	1 118	2 220	1 230	990	1 170
8 560	4 660	3 370	3 450	3 355	M30	1 118	2 220	1 230	1 000	1 170
8 560	4 660	3 370	3 450	3 355	M30	1 118	2 200	1 230	1 000	1 170
8 560	4 660	3 370	3 450	2 900	M30	1 118	2 200	1 230	1 000	1 170
9 980	5 430	3 930	4 020	3 480	M36	1 945	3 260	1 800	1 460	1 720
9 980	5 430	3 930	4 020	2 690	M36	1 945	3 260	1 800	1 460	1 720
11 060	6 020	4 350	4 450	4 250	M36	1 945	3 100	1 710	1 390	1 630
11 060	6 020	4 350	4 450	4 295	M36	1 945	3 100	1 710	1 390	1 630
11 960	6 510	4 710	4 820	4 600	M36	1 945	3 100	1 710	1 390	1 630
11 960	6 510	4 710	4 820	3 628	M36	1 945	3 100	1 710	1 390	1 630
11 960	6 510	4 710	4 820	4 200	M36	1 945	3 100	1 710	1 390	1 630
13 870	7 560	5 460	5 590	5 330	M36	1 945	3 200	1 770	1 430	1 690
13 870	7 560	5 460	5 590	3 200	M36	1 945	3 200	1 770	1 430	1 690
13 870	7 560	5 460	5 590	4 535	M36	1 945	3 200	1 770	1 430	1 690
15 140	8 250	5 960	6 100	5 650	M42	2 794	4 110	2 270	1 840	2 160
15 140	8 250	5 960	6 100	5 650	M42	2 794	4 110	2 270	1 840	2 160
15 140	8 250	5 960	6 100	4 530	M42	2 794	4 110	2 270	1 840	2 160
16 460	8 970	6 480	6 630	6 320	M42	2 794	4 110	2 270	1 840	2 160
16 460	8 970	6 480	6 630	4 360	M42	2 794	4 110	2 270	1 840	2 160
16 460	8 970	6 480	6 630	6 350	M42	2 794	4 110	2 270	1 840	2 160
18 120	9 870	7 130	7 300	6 962	M42	2 794	4 160	2 300	1 860	2 190
18 120	9 870	7 130	7 300	4 747	M42	2 794	4 160	2 300	1 860	2 190
19 560	10 660	7 700	7 880	7 420	M42	2 794	4 160	2 300	1 860	2 190
19 560	10 660	7 700	7 880	4 500	M42	2 794	4 160	2 300	1 860	2 190



3.6 Lubrication

Split plummer block housings SNS are principally intended for grease lubrication. However, a design for oil lubrication is also available by agreement.

Lubricating greases

 *Arcanol rolling bearing greases*

In order to achieve a long operating life and high operational security of the bearing arrangement, we recommend the use of rolling bearing greases Arcanol ▶92|6.5. These have been designed and tested for bearing arrangement engineering.

 *Basic rule for initial greasing*

For initial greasing, the basic rule is that the bearing should be filled with grease to 100% and the free volume of the housing to 60%. The free volume is the space that remains in the housing once the bearing, adapter sleeve, shaft and seals have been fitted.

 *Recommended grease quantity*

The recommended grease quantity can also be stated in grams once the density of the grease has been taken into consideration ▶1632|6.

The recommended grease quantity takes account of:

- filling of the free volume to 60%
- grease with a density of 0,9 g/cm³.

 **6**
Recommended grease quantity for selected housing/bearing combinations

Information on the recommended grease quantity for other housing sizes is available by agreement.

Housing	Bearing	Adapter sleeve	Free volume (100%) cm ³	Recommended grease quantity ≈ g	
SNS22	SNS2264-H-D	22264..-K	H3064	27 550	14 900
SNS30	SNS3036-H-D	23036..-K	H3036	2 900	1 600
	SNS3038-H-D	23038..-K	H3038	3 900	2 250
	SNS3040-H-D	23040..-K	H3040	5 020	3 050
	SNS3044-H-D	23044..-K	H3044	5 770	4 260
	SNS3048-H-D	23048..-K	H3048	7 280	4 550
	SNS3052-H-D	23052..-K	H3052	9 930	6 750
	SNS3056-H-D	23056..-K	H3056	12 500	6 750
	SNS3060-H-D	23060..-K	H3060	14 800	8 000
	SNS3064-H-D	23064..-K	H3064	19 400	10 500
	SNS3068-H-D	23068..-K	H3068	24 000	13 000
	SNS3072-H-D	23072..-K	H3072	30 400	16 450
	SNS3076-H-D	23076..-K	H3076	32 000	17 300
	SNS3080-H-D	23080..-K	H3080	33 500	18 100
	SNS3084-H-D	23084..-K	H3084	35 000	18 900
	SNS3088-H-D	23088..-K	H3088	43 400	23 450
	SNS3092-H-D	23092..-K	H3092	56 600	30 600
	SNS3096-H-D	23096..-K	H3096	55 200	29 850
	SNS30/500-H-D	230/500..-K	H30/500	55 200	29 850
	SNS30/530-H-D	230/530..-K	H30/530	67 500	36 450

continued ▼

6

Recommended grease quantity for selected housing/bearing combinations

Information on the recommended grease quantity for other housing sizes is available by agreement.

Housing	Bearing	Adapter sleeve	Free volume (100%) cm ³	Recommended grease quantity ≈ g	
SNS31	SNS3134-H-D	23134...-K	H3134	2 900	1 600
	SNS3136-H-D	23136...-K	H3136	3 810	2 060
	SNS3138-H-D	23138...-K	H3138	5 030	2 720
	SNS3140-H-D	23140...-K	H3140	6 780	3 660
	SNS3144-H-D	23144...-K	H3144	7 520	4 060
	SNS3148-H-D	23148...-K	H3148	10 100	5 990
	SNS3152-H-D	23152...-K	H3152	11 650	6 300
	SNS3156-H-D	23156...-K	H3156	12 550	6 800
	SNS3160-H-D	23160...-K	H3160	17 200	9 300
	SNS3164-H-D	23164...-K	H3164	21 250	11 500
	SNS3168-H-D	23168...-K	H3168	27 550	14 900
	SNS3172-H-D	23172...-K	H3172	28 500	15 400
	SNS3176-H-D	23176...-K	H3176	28 300	15 300
	SNS3180-H-D	23180...-K	H3180	36 450	19 700
	SNS3184-H-D	23184...-K	H3184	45 550	24 600
	SNS3188-H-D	23188...-K	H3188	48 300	26 100
	SNS3192-H-D	23192...-K	H3192	52 000	28 100
SNS3196-H-D	23196...-K	H3196	55 000	29 700	
SNS32	SNS3234-H-D	23234...-K	H2334	5 350	2 900
	SNS3236-H-D	23236...-K	H2336	5 350	2 900
	SNS3238-H-D	23238...-K	H2338	6 500	3 510
	SNS3240-H-D	23240...-K	H2340	6 900	3 760
	SNS3244-H-D	23244...-K	H2344	10 000	5 400
	SNS3248-H-D	23248...-K	H2348	10 200	5 550
	SNS3252-H-D	23252...-K	H2352	15 500	8 400
	SNS3256-H-D	23256...-K	H2356	15 500	8 400
	SNS3260-H-D	23260...-K	H3260	19 000	10 300
	SNS3264-H-D	23264...-K	H3264	25 300	13 700
	SNS3268-H-D	23268...-K	H3268	25 000	13 500
	SNS3272-H-D	23272...-K	H3272	26 800	14 500
	SNS3276-H-D	23276...-K	H3276	38 600	20 850
	SNS3280-H-D	23280...-K	H3280	44 100	23 850
SNS3284-H-D	23284...-K	H3284	45 000	24 350	
SNS3288-H-D	23288...-K	H3288	49 400	26 700	

continued ▲





Deviation from basic rule

The recommended degree of filling for the greasing of bearings, as a function of the application and speed, may deviate from 100%.

Relubrication



 *Bearings with circumferential lubrication groove*

Where relubrication is carried out on bearings with a circumferential lubrication groove, the grease is introduced into the housing via the central lubrication hole  1635 |  6. In this type of relubrication, the grease acts directly on the bearing.

 *Bearings without lubrication groove*

For the relubrication of bearings without a lubrication groove, two relubrication points are provided in the upper housing section. One of the two points has a threaded hole, while the other is indicated by a cast-in pilot hole.

 *Lubrication holes and lubrication nipples*

The lubrication holes and lubrication nipples provided for relubrication differ according to the design of the housing  1634 |  7. In the case of housings SNS...H and SNS...Z, the threaded holes are closed off by a screw plug. This must be removed and permanently replaced by one of the lubrication nipples supplied. In the case of housings SNS...B, both taper type lubrication nipples are already fitted.

 7
Lubrication holes and lubrication nipples

Housing	Thread	Lubrication nipple	Delivery quantity
SNS...H SNS...Z	M10×1	Button head lubrication nipple to DIN 3404-M10×1 (with dust cap)	1
		Taper type lubrication nipple to DIN 71412-AM10×1 (with dust cap)	1
SNS...B	ISO 288-G1/4	Button head lubrication nipple to DIN 3404-A G1/4 St	2

 *Positions for further lubrication holes*

Lubrication holes can be provided at two further points for relubrication of labyrinth seals. These positions are indicated by marks on the housing.

 *Prevention of overgreasing*

In order to prevent overgreasing, the screw plugs must be removed from the two grease outlet holes in the lower housing section for the duration of relubrication. This allows superfluous grease to escape. The grease outlet holes must then be closed off again using the screw plugs.



If unfavourable environmental conditions are present, there is therefore a risk of contaminant ingress into the housing when the grease outlet holes are opened.

6 Positions for relubrication

- ① Central lubrication hole, for bearings with lubrication groove
- ② Points for relubrication of bearings without lubrication groove
- ③ Points for relubrication of labyrinth seals
- ④ Grease outlet holes

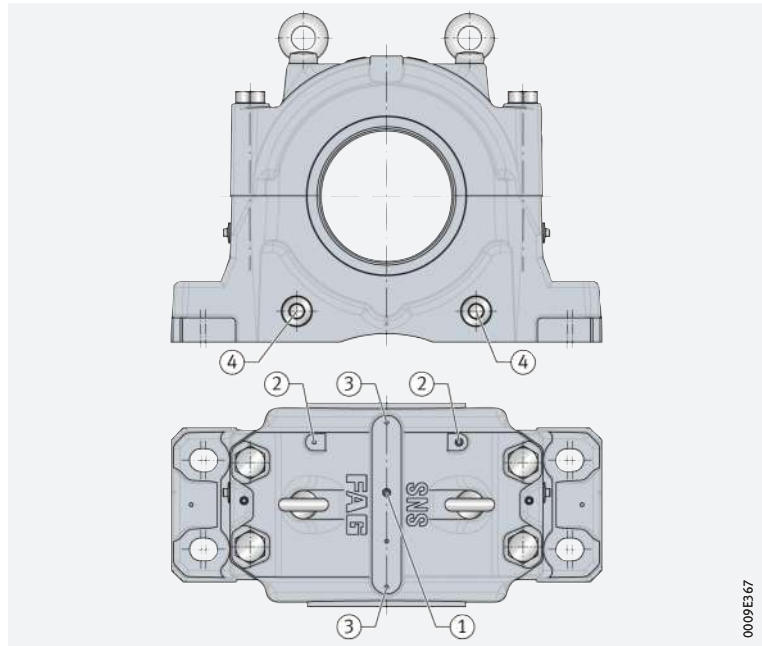

3.7 Sealing

Seals

Standard seals

For sealing of the bearing housings, the following standard seals are available:

- labyrinth seals and taconite seals, each in a split and unsplit design. These seals are matched to the rectangular section annular slots on both sides of the housings SNS..-H and SNS..-Z
- Bolt-on seal. This seal is screw mounted to the outside of housings SNS..-B.

Seals must be ordered separately. They are supplied individually. If a continuous shaft is present, two seals are necessary.

Labyrinth seals NTS

Non-contact seal for high circumferential velocities

Labyrinth seals NTS give non-contact sealing. They are therefore suitable for high circumferential velocities. The O ring, which is pressed between the labyrinth ring and shaft, is made from fluoro rubber FKM and is suitable for temperatures of up to +200 °C. The labyrinth seal allows shaft misalignment of up to 0,3° in both directions and is suitable for grease lubrication.

Relubrication

If necessary, the labyrinth can be relubricated. For this purpose, a lubrication hole must be made in the upper housing section for each labyrinth seal. The optimum positions are indicated by cast-in pilot holes.

Taconite seals NTC

Seals for extreme contamination impact

Taconite seals NTC are combined seals comprising a labyrinth seal and a V ring. These seals are suitable for extreme operating conditions in relation to contamination and dust. The V ring is made from NBR and is suitable for temperatures of up to +100 °C.

The taconite seal allows shaft misalignment of up to 0,3° in both directions and is suitable for grease lubrication. For relubrication, the seal is fitted with a lubrication nipple.

Split labyrinth seals NTSG

Split seal reduces mounting work

For plummer block housings SNS, labyrinth seals are also available in a split design. As a result, the work involved in fitting or replacing the seal can be considerably reduced, especially if a split bearing is also fitted.

The characteristics and operating limits correspond to those of the unsplit labyrinth seal NTS.

Split labyrinth seals NTSG are available in various sizes ► 1636 | 8. Other sizes are available by agreement.

8 Sizes

Sizes of split labyrinth seals for	
Metric shaft	Inch size shaft
NTSG34	NTSG34×515
NTSG36	NTSG36×607
NTSG38	–
NTSG40	–
NTSG44	–
NTSG48	–
NTSG52	–

Split taconite seals NTCC

Split seal reduces mounting work

For plummer block housings SNS, taconite seals are also available in a split design. As a result, the work involved in fitting or replacing the seal can be considerably reduced, especially if a split bearing is also fitted. Split taconite seals are supplied by agreement.

 *Seal for extreme contamination impact*

Bolt-on seal BTAC

Bolt-on seals BTAC are combined seals comprising a labyrinth ring and a V ring. They are screw mounted to the outside of the housing and, unlike all other seals for plummer block housings SNS, are not inserted in the annular slots in the housing. The seals are suitable for extreme operating conditions in relation to contamination and dust. The V ring is made from NBR and is suitable for temperatures of up to +100 °C.

The Bolt-on seal allows shaft misalignment of up to 0,4° in both directions and is suitable for grease lubrication. For relubrication, the seal is fitted with a lubrication nipple.

The seals are available in the sizes BTAC34 to BTAC68.

 *Special housing design required*

When using Bolt-on seals, housings of a special design SNS..-B are required instead of the designs SNS..-H and SNS..-Z suitable for all other seals.

Covers

Covers are used in the case of housings closed on one side. The covers must be ordered separately.

Covers NDK

 *For housings with annular slot*

Covers NDK fit in the rectangular section annular slots of the housings, designed for labyrinth and taconite seals, SNS..-H and SNS..-Z. They are suitable for temperatures up to +200 °C.

Covers BDK

 *For housings with Bolt-on seal*

Covers BDK are screw mounted to the outside of the housing. They are suitable for the housings SNS..-B designed for the Bolt-on seal.

Characteristics and operating limits

The characteristics and operating limits of the standard seals and covers are compared in an overview ► 1638 .





Standard seals and covers for plummer block housings SNS

++ = highly suitable

+ = suitable

(+) = suitable with restrictions

- = not suitable

Seals and covers

Labyrinth seal, unsplit

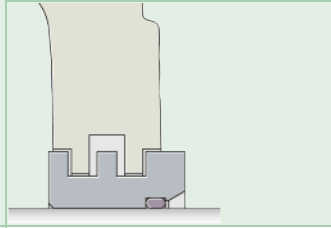

Designation	NTS
Material	Steel, FKM
Pieces per pack	1

Suitability for sealing against

dust	(+)
fine, solid particles	+
coarse, solid particles	+
slivers	++
spray liquids	-

Operating limits

Long term temperature	°C	-20 to +200 (due to FKM)
	°F	-4 to +390 (due to FKM)
Circumferential velocity	m/s	No restriction
Misalignment	°	≤0,3
Low friction		++
Axial shaft displacement (suitability as non-locating bearing)		+
Vertical arrangement		-
Suitability for grease relubrication		+
Suitability for oil lubrication		-
Compatibility with sunlight		++

Preconditions

Tolerance class ¹⁾ of shaft diameter		h8 (h9)
Shaft roughness	μm	Ra 3,2

¹⁾ The envelope requirement © applies

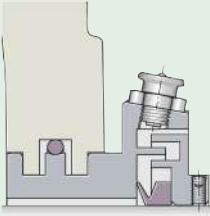
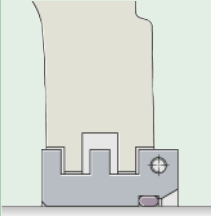
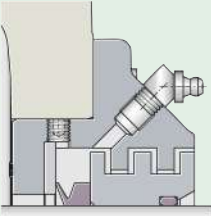
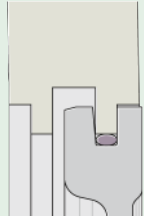
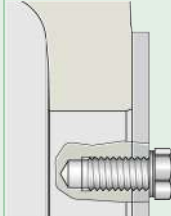
Taconite seal, unsplit	Labyrinth seal, split	Bolt-on seal, unsplit	Covers	
				
NTC	NTSG	BTAC	NDK	BDK
Steel, NBR	Steel, FKM	Steel, NBR	Steel, FKM	Steel
1	1	1	1	1
++	(+)	++	++	++
++	+	++	++	++
++	+	++	++	++
++	++	++	++	++
++	-	++	++	++
-30 to +100 (due to NBR)	-20 to +200 (due to FKM)	-30 to +100 (due to NBR)	-20 to +200 (due to FKM)	Not applicable
-22 to +210 (due to NBR)	-4 to +390 (due to FKM)	-22 to +210 (due to NBR)	-4 to +390 (due to FKM)	Not applicable
≤ 12	No restriction	≤ 12	Not applicable	Not applicable
$\leq 0,3$	$\leq 0,3$	$\leq 0,4$	Not applicable	Not applicable
+	++	+	Not applicable	Not applicable
+	+	+	Not applicable	Not applicable
(+)	-	-	++	++
+	+	++	++	++
(+)	-	-	+	-
++	++	++	++	++
h8 (h9)	h8 (h9)	h8 (h9)	Not applicable	Not applicable
Ra 3,2	Ra 3,2	Ra 3,2	Not applicable	Not applicable



3.8 Dimensions, tolerances

Dimensions



The dimensions of the housings conform to ISO 113.

Interchangeability

FAG plummer block housings SNS are a further development of the FAG plummer block housings SD31. The design envelope and mounting dimensions of both series of housings are identical and the housings are interchangeable 1:1.

The interchangeability with other series of FAG housings is as follows:

- All bearing series that can be combined with the plummer block housings SD5 and SD6 can be fitted in plummer block housings SNS
- Bearing series that can be combined with the plummer block housings S30 can only be fitted in certain cases in plummer block housings SNS.



The dimensions of housings SD5, SD6 and S30 are not identical with the dimensions of housings SNS.

Tolerances for the bearing seat



The bearing seat in split plummer block housings SNS is machined to the tolerance class G7 in accordance with DIN EN ISO 286-1.

By agreement, the housings can also be supplied with other tolerance classes for the bearing seat.

3.9 Housing configurations

Modular construction allows numerous combinations

Possible combinations

On the basis of the standard components, the following features can be varied in the housing configuration:

- location of bearings with a tapered bore by means of an adapter sleeve on a shaft of constant diameter or of bearings with a cylindrical bore directly on a stepped shaft
- sealing of housing by labyrinth seals (unsplit or split), taconite seals (unsplit or split) or Bolt-on seals (in combination with housings of design SNS...-B)
- with a continuous shaft or a housing closed on one side
- design of the bearing arrangement as a locating bearing arrangement or a non-locating bearing arrangement
- spherical roller bearing in a split or unsplit design.

The resulting possible housing configurations make it possible to fulfil various requirements on the bearing positions by means of standard components ▶ 1640 | 7 to ▶ 1643 | 16.

 7
Plummer block housing SNS
for bearings with tapered bore and
adapter sleeve
(2 labyrinth seals NTS)

- ① Locating bearing
- ② Non-locating bearing

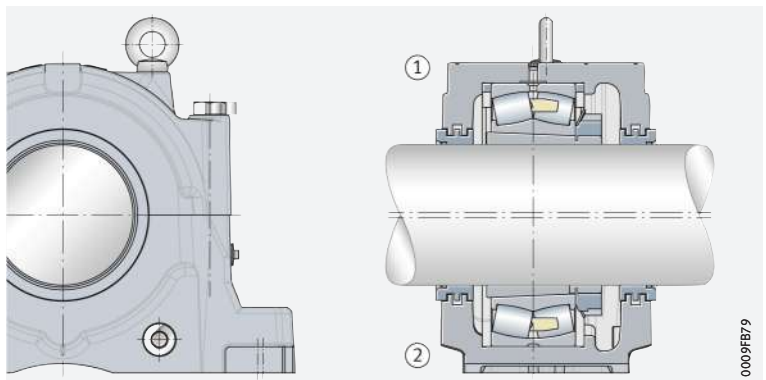

8

Plummer block housing SNS
for bearings with tapered bore and
adapter sleeve
(labyrinth seal NTS and
cover NDK)

- ① Locating bearing
- ② Non-locating bearing

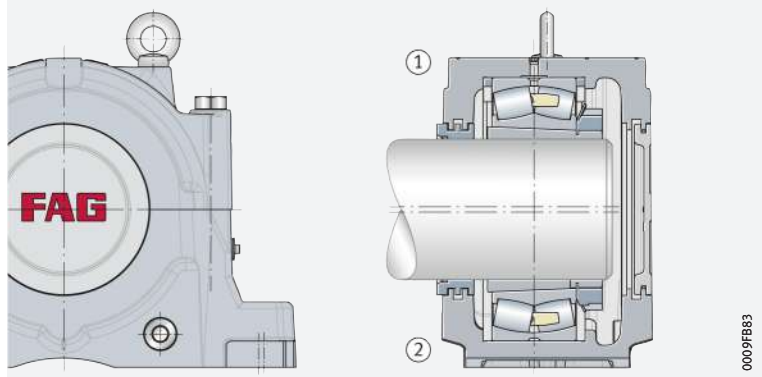

0009FB83

9

Plummer block housing SNS
for bearings with tapered bore and
adapter sleeve
(2 taconite seals NTC)

- ① Locating bearing
- ② Non-locating bearing

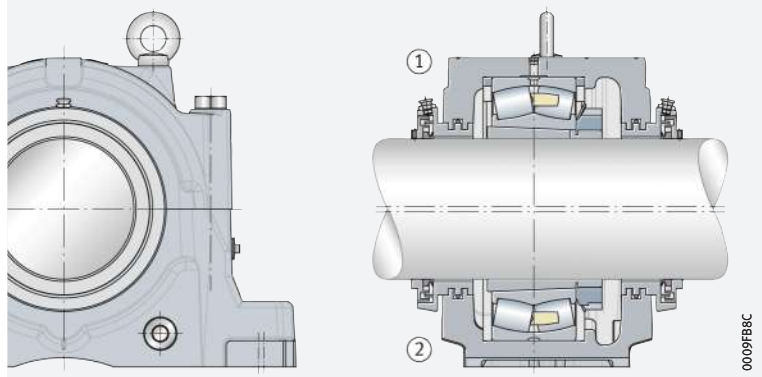

0009FB8C

10

Plummer block housing SNS
for bearings with tapered bore and
adapter sleeve
(taconite seal NTC and cover NDK)

- ① Locating bearing
- ② Non-locating bearing

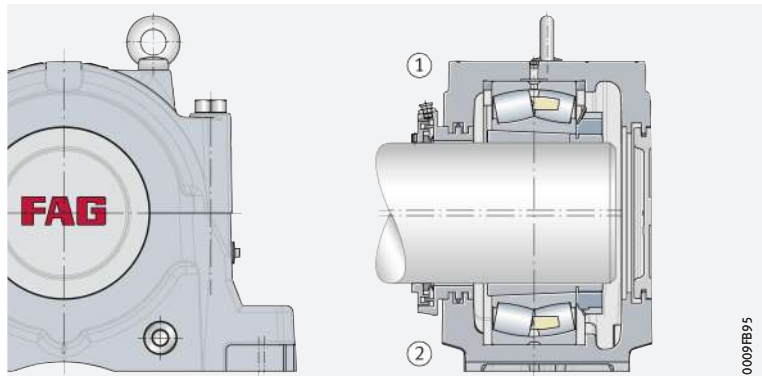

0009FB95

11

Plummer block housing SNS
for bearings with cylindrical bore
(2 labyrinth seals NTS)

- ① Locating bearing
- ② Non-locating bearing

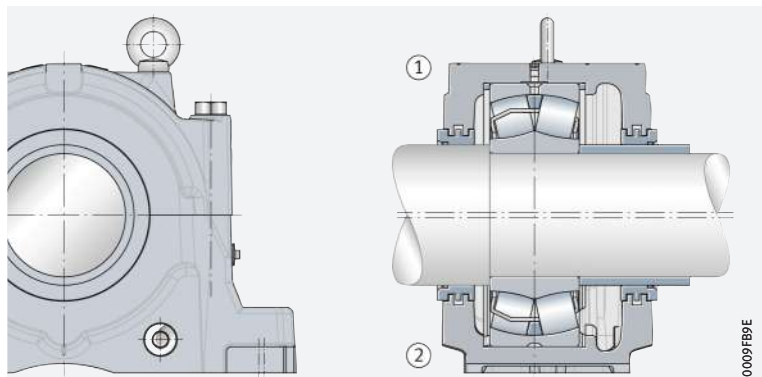

0009FB9E



12

Plummer block housing SNS
for bearings with cylindrical bore
(labyrinth seal NTS and
cover NDK)

- ① Locating bearing
- ② Non-locating bearing

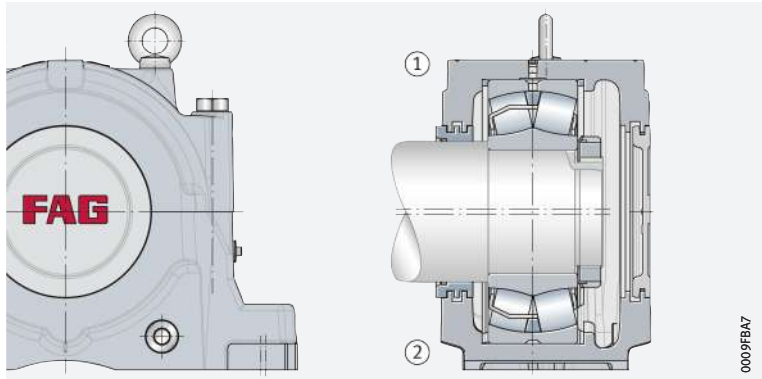

13

Plummer block housing SNS
for bearings with cylindrical bore
(2 taconite seals NTC)

- ① Locating bearing
- ② Non-locating bearing

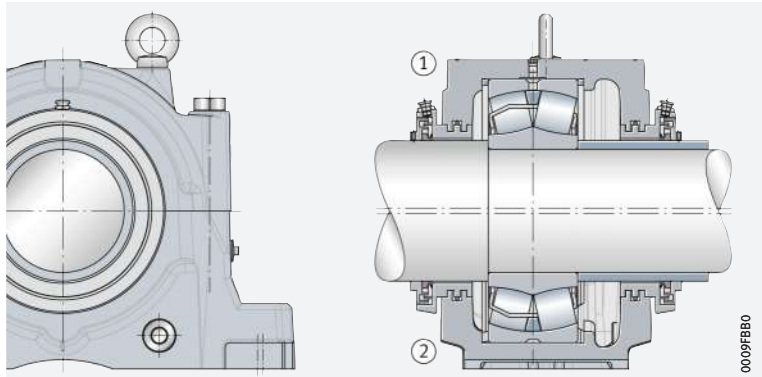

14

Plummer block housing SNS
for bearings with cylindrical bore
(taconite seal NTC and cover NDK)

- ① Locating bearing
- ② Non-locating bearing

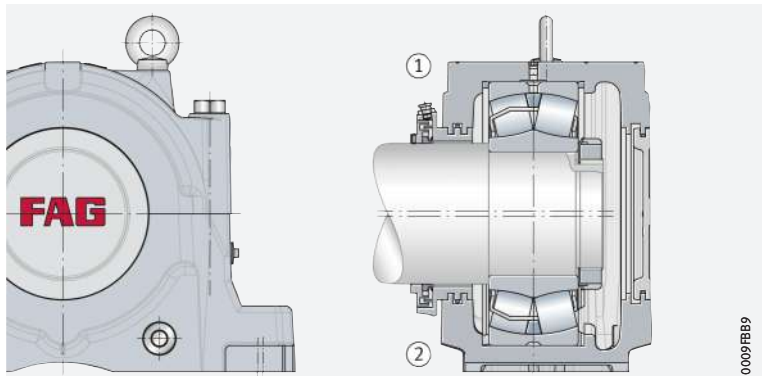

15

Plummer block housing SNS
for bearings with tapered bore and
adapter sleeve
(2 Bolt-on seals BTAC)

- ① Locating bearing
- ② Non-locating bearing

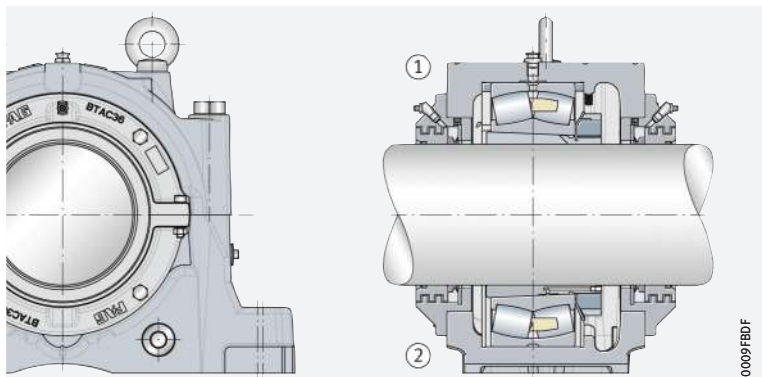

16

Plummer block housing SNS for bearings with tapered bore and adapter sleeve (Bolt-on seal BTAC and cover BDK)

- ① Locating bearing
- ② Non-locating bearing

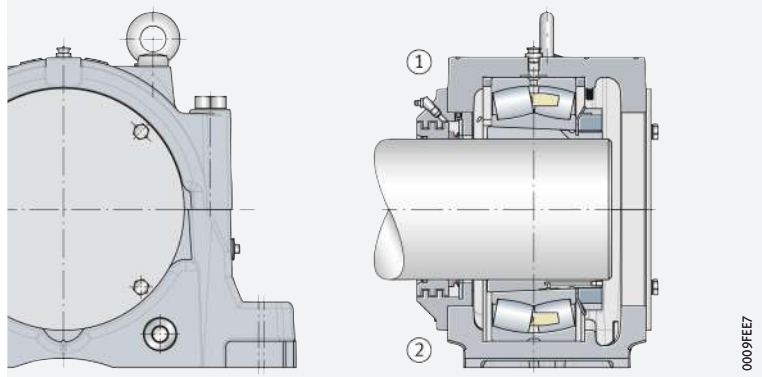

0009FEE7

Mounting of split spherical roller bearings

Simplified bearing replacement by means of split bearing

In the case of plummer block housings SNS, an unsplit spherical roller bearing with a tapered bore and adapter sleeve can be replaced by a split spherical roller bearing ► 1643 | 17.

17

Plummer block housing SNS with split and unsplit spherical roller bearing

- ① Locating bearing with unsplit bearing
- ② Non-locating bearing with unsplit bearing
- ③ Locating bearing with split bearing
- ④ Non-locating bearing with split bearing

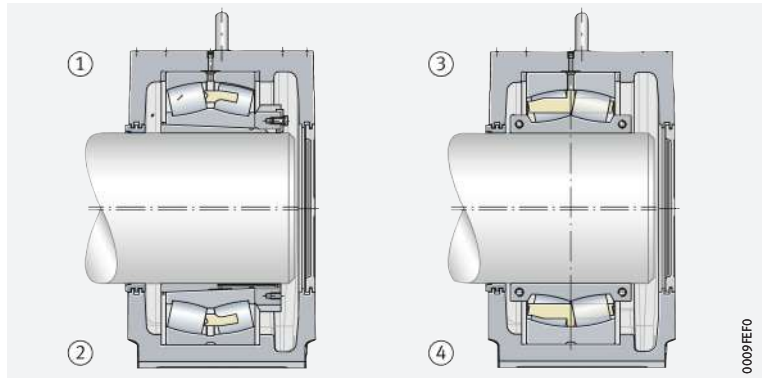

0009FEF0



In order to ensure selection of the correct combination of housing and bearing when using split bearings, please contact Schaeffler.



The range of split spherical roller bearings is described in detail in a separate publication ► TPI 250.



3.10 Structure of housing designation

The designation of the housings and associated seals, covers and locating rings follows a set model. Description of the designation components [▶ 1644](#) | [10](#) to [▶ 1646](#) | [14](#). Structure of designations [▶ 1644](#) | [18](#) to [▶ 1646](#) | [21](#).

10
 Components of the designations
 of plummer block housings SNS

Characteristic	Code	Description
① Series	SNS	Split plummer block housings SNS
② ISO dimension series of bearing	30	ISO dimension series 22, 23, 30 and 40
	31	ISO dimension series 22, 23 and 31
	32	ISO dimension series 22 and 32
	40	ISO dimension series 40
③ Housing size	36	For bearings of ISO dimension series 30, 31 and 32:
	/530	■ Bore code of bearing
④ Housing design	H	Main design ▶ 1644 11
	Z	Additional design ▶ 1644 11
	B	Design for Bolt-on seal
⑤ Housing material	D	Spheroidal graphite cast iron

18
 Designation structure
 of plummer block housings SNS,
 example



Plummer block housings SNS with labyrinth and taconite seals are available in the housing designs H and Z. Spherical roller bearings can be fitted, as a function of the bearing series, in one of the two housing designs [▶ 1644](#) | [11](#).

11
 Allocation of housing
 designs H and Z
 to bearing types

Housing design	Bearing series
H	Spherical roller bearings with tapered bore and adapter sleeve
	Split spherical roller bearings
Z	Following spherical roller bearings with cylindrical bore: 22232, 22234, 22252, 22272, 22326, 22328, 22330, 22332, 22334, 22338, 22344, 22348, 22352, 22356, 23232, 24036
	Spherical roller bearings with cylindrical bore, not allocated to housing design H

12

Components of the designations of standard seals

Characteristic	Code	Description
① Series	NTS	Labyrinth seal, unsplit
	NTC	Taconite seal, unsplit
	NTSG	Labyrinth seal, split
	BTAC	Bolt-on seal, unsplit
② Dimension series	36	Dimension series 36
③ Shaft diameter	No further indications	Standard shaft diameter of dimension series
	/125	Metric shaft diameter: ■ 125 mm
	X415	Inch size shaft diameter: ■ 4 inch + 15 · 1/16 inch = 4 ¹⁵ /16 inch

19

Designation structure of standard seals, examples

000A1.2D0

13

Components of designations of covers

Characteristic	Code	Description
① Series	NDK	Cover for plummer block housings SNS...H and SNS...Z
	BDK	Cover for plummer block housing SNS...B
② Dimension series	36	Dimension series 36

20
 Designation structure
 of covers,
 example

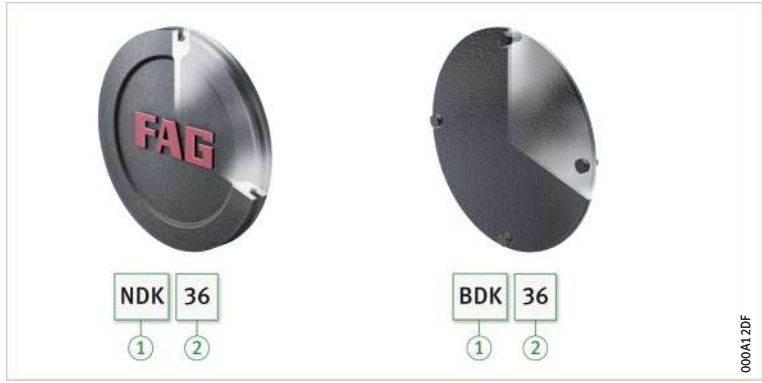

14
 Components of designations
 of locating rings

Characteristic	Code	Description
① Series	NFR	Locating ring
② Outside diameter	280	Outside diameter 280 mm
③ Width	10	Width 10 mm

21
 Designation structure
 of locating rings,
 example

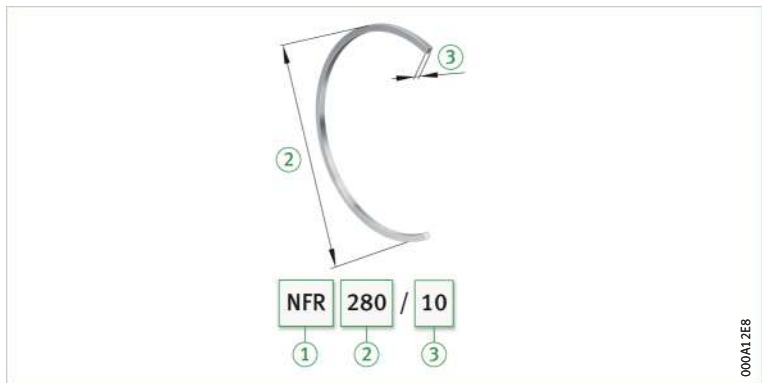

*Separate ordering
 of housing body and
 accessories*

Ordering examples

When a split plummer block housing SNS is ordered, the housing designation only describes the housing body. The other components such as seals, covers or locating rings must be ordered separately in the specific design required. The rolling bearing and, if necessary, the adapter sleeve must also be ordered separately.

Plummer block housings SNS with a bearing fitted give non-locating bearing arrangements. These can be converted into locating bearing arrangements through the additional insertion of locating rings NFR.

The ordering examples show the construction of orders for selected housing combinations and the appropriate bearings. The allocation of housings, bearings and accessories for all housing sizes is shown in the product tables ▶ 1650 |

Example 1

Plummer block housing SNS made from spheroidal graphite cast iron, closed on one side, spherical roller bearing 23136-E1A-K-M as locating bearing, location by means of adapter sleeve on shaft diameter of 160 mm, labyrinth seal.

- | | | |
|-------|----------------------------|---------------|
| Order | 1 plummer block housing | SNS3136-H-D |
| | 1 spherical roller bearing | 23136-E1A-K-M |
| | 1 adapter sleeve | H3136-HG |
| | 2 locating rings | NFR300/10 |
| | 1 cover | NDK36 |
| | 1 labyrinth seal | NTS36 |

Example 2

Plummer block housing SNS made from spheroidal graphite cast iron, continuous shaft, spherical roller bearing 23136-E1A-K-M as non-locating bearing, location by means of adapter sleeve on shaft diameter of 160 mm, taconite seal.

 <i>Order</i>	1 plummer block housing	SNS3136-H-D
	1 spherical roller bearing	23136-E1A-K-M
	1 adapter sleeve	H3136-HG
	2 taconite seals	NTC36

Example 3

Plummer block housing SNS made from spheroidal graphite cast iron, closed on one side, spherical roller bearing 23136-E1A-K-M as non-locating bearing, location by means of adapter sleeve on shaft diameter of 160 mm, Bolt-on seal.

 <i>Order</i>	1 plummer block housing	SNS3136-B-D
	1 spherical roller bearing	23136-E1A-K-M
	1 adapter sleeve	H3136-HG
	1 cover	BDK36
	1 Bolt-on seal	BTAC36

3.11 Mounting and dismounting

Eye bolts



The upper housing section has 2 eye bolts in accordance with DIN 580. These are intended as locating points for mounting and dismounting of the housing. The load carrying capacity of the eye bolts allows lifting of the housing including a bearing fitted in the housing.



Eye bolts must always be screwed fully into the housing.

Eye bolts must not be subjected to a mass greater than that of the housing together with the bearing fitted in the housing.

Foot screws

Foot screws are used for screw mounting of the housing to the mounting surface. They are not included in the scope of delivery of the housings.

The appropriate screw size for each housing is given in the product tables  **▶ 1650**.

 *Tightening torques for foot screws*

The following table contains tightening torques for metric coarse pitch threads in accordance with DIN 13, DIN 962 and DIN ISO 965-2.

The maximum tightening torques are valid when utilising 90% of the yield stress of the screw material 8.8 and with a friction factor of 0,14. We recommend that foot screws should be tightened to approx. 70% of these values  **▶ 1647**.



 **15**
Tightening torques for foot screws with metric thread in accordance with DIN 13, DIN 962 and DIN ISO 965-2

Nominal screw diameter	Maximum tightening torque Nm	Recommended tightening torque Nm
M24	798	550
M30	1 597	1 100
M36	2 778	1 950
M42	3 991	2 750
M48	6 021	4 250



 *No contact between shaft and cover*

Permissible shaft end designs

In the case of a housing closed on one side, the length of the shaft in the housing must be restricted such that no contact occurs between the shaft and the cover. In this case, the displacement facility of the bearing in a non-locating bearing arrangement must be taken into consideration. The basis for determining the permissible length of the shaft is the spacing between the centre of the bearing seat and the cover \blacktriangleright 1648 |  22 and \blacktriangleright 1648 |  16.

 **22**
 Spacing between centre of bearing seat and cover

a_d = spacing between centre of bearing seat and cover

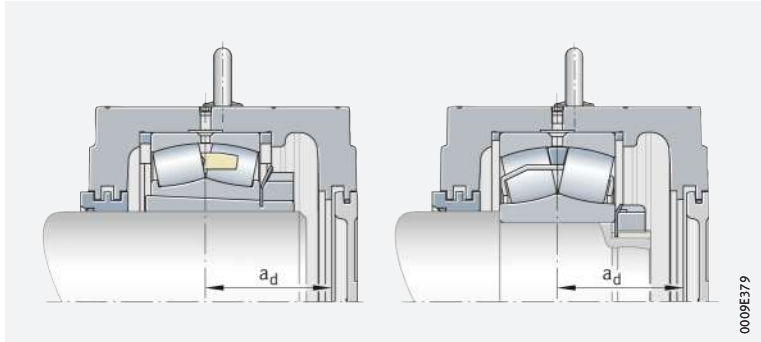

 **16**
 Spacing between centre of bearing seat and cover

Housing					Spacing
SNS22	SNS30	SNS31	SNS32	SNS40	a_d mm
-	SNS3036	SNS3134	-	-	107,5
-	SNS3038	SNS3136	-	-	113,5
-	SNS3040	SNS3138	SNS3234	-	117,5
-	-	-	SNS3236	-	117,5
-	SNS3044	SNS3140	SNS3238	-	127,5
-	SNS3048	SNS3144	SNS3240	-	133,5
-	SNS3052	SNS3148	SNS3244	-	141,5
-	SNS3056	SNS3152	SNS3248	-	151,5
-	SNS3060	SNS3156	-	-	154,5
-	SNS3064	SNS3160	SNS3252	-	175,5
-	-	-	SNS3256	-	175,5
-	SNS3068	SNS3164	SNS3260	-	186,5
-	SNS3072	-	-	-	186,5
SNS2264	SNS3076	SNS3168	SNS3264	SNS4076	202,5
-	SNS3080	SNS3172	SNS3268	SNS4080	208,5
-	SNS3084	SNS3176	-	SNS4084	208,5
-	SNS3088	SNS3180	SNS3272	SNS4088	223,5
-	SNS3092	SNS3184	SNS3276	SNS4092	243,5
-	SNS3096	SNS3188	SNS3280	SNS4096	243,5
-	SNS30/500	-	-	SNS40/500	243,5
-	SNS30/530	SNS3192	SNS3284	SNS40/530	248,5
-	-	SNS3196	SNS3288	-	248,5

Detailed information on mounting



Careful and correct mounting of the bearing housing, including the correct mounting of the rolling bearing in the housing, is fundamental to reliable operation. Detailed information is given in the publication MON 84 \blacktriangleright <https://www.schaeffler.de/std/1D63>.

3.12 Legal notice regarding data freshness

The further development of products may also result in technical changes to catalogue products

Of central interest to Schaeffler is the further development and optimisation of its products and the satisfaction of its customers. In order that you, as the customer, can keep yourself optimally informed about the progress that is being made here and with regard to the current technical status of the products, we publish any product changes which differ from the printed version in our electronic product catalogue.



We therefore reserve the right to make changes to the data and illustrations in this catalogue. This catalogue reflects the status at the time of printing. More recent publications released by us (as printed or digital media) will automatically precede this catalogue if they involve the same subject. Therefore, please always use our electronic product catalogue to check whether more up-to-date information or modification notices exist for your desired product.

Link to electronic product catalogue



The following link will take you to the Schaeffler electronic product catalogue: ► <https://medias.schaeffler.com>.



3.13 Further information



In addition to the data in this chapter, the following chapters must also be observed in the selection of a housing:

- Lubrication ► 70|6
- Locating and non-locating bearing concepts ► 1571|1.2
- Housing materials ► 1573|1.3

Further information:

- Product tables on split plummer block housings SNS for inch size shaft diameters ►  GK 1
- Product tables on split plummer block housings SNS in combination with Bolt-on seals ►  GK 1
- Electronic housing selection wizard
► <https://www.schaeffler.de/std/1D61>



Plummer block housings

SNS, split
For spherical roller bearings with tapered bore and adapter sleeve, metric shaft

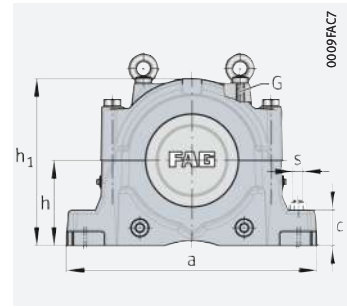
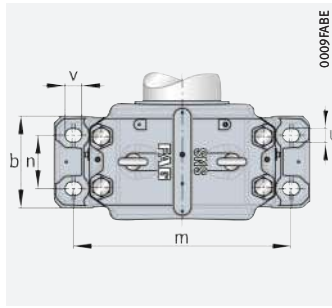

d₁ = 115 – 170 mm

Shaft d ₁	Housing Dimensions															Mass m ≈ kg	Housing Designation ▶ 1644 3.10
	h	h ₁	g	b	c	a	m	n	v	u	s	D	k	e	G		
115	170	333	230	180	70	510	430	100	34	28	M24	280	108	14	M16	75	SNS3134-H-D
125	180	353	240	190	75	530	450	110	34	28	M24	300	116	15	M16	83	SNS3136-H-D
135	190	375	260	210	80	560	480	120	34	28	M24	320	124	10	M20	102	SNS3138-H-D
140	180	353	240	190	75	530	450	110	34	28	M24	290	115	15	M16	86	SNS3038-H-D
	210	411	280	230	85	610	510	130	42	35	M30	340	132	10	M20	133	SNS3140-H-D
	180	353	240	190	75	530	450	110	34	28	M24	290	115	15	M16	86	SNS3038-H-D
150	190	375	260	210	80	560	480	120	34	28	M24	310	122	10	M20	105	SNS3040-H-D
	220	434	290	240	90	640	540	140	42	35	M30	360	140	12	M20	148	SNS3048-H-D
	170	333	230	180	70	510	430	100	34	28	M24	280	108	14	M16	75	SNS3134-H-D
	170	333	230	180	70	510	430	100	34	28	M24	280	108	14	M16	75	SNS3134-H-D
	190	375	260	210	80	560	480	120	34	28	M24	310	122	10	M20	105	SNS3234-H-D
160	190	375	260	210	80	560	480	120	34	28	M24	320	124	10	M20	102	SNS3138-H-D
	170	333	230	180	70	510	430	100	34	28	M24	280	108	14	M16	74	SNS3036-H-D
	170	333	230	180	70	510	430	100	34	28	M24	280	108	14	M16	74	SNS3036-H-D
	180	353	240	190	75	530	450	110	34	28	M24	300	116	15	M16	83	SNS3136-H-D
	180	353	240	190	75	530	450	110	34	28	M24	300	116	15	M16	83	SNS3136-H-D
	190	375	260	210	80	560	480	120	34	28	M24	320	124	10	M20	102	SNS3236-H-D
170	210	411	280	230	85	610	510	130	42	35	M30	340	132	10	M20	133	SNS3140-H-D
	240	474	310	260	95	700	600	150	42	35	M30	400	148	12	M24	184	SNS3148-H-D
	180	353	240	190	75	530	450	110	34	28	M24	290	115	15	M16	86	SNS3038-H-D
	180	353	240	190	75	530	450	110	34	28	M24	290	115	15	M16	86	SNS3038-H-D
	190	375	260	210	80	560	480	120	34	28	M24	320	124	10	M20	102	SNS3138-H-D
	190	375	260	210	80	560	480	120	34	28	M24	320	124	10	M20	102	SNS3138-H-D
	210	411	280	230	85	610	510	130	42	35	M30	340	132	10	M20	133	SNS3238-H-D

medias ▶ <https://www.schaeffler.de/std/1F1A>

① Locating bearing; ② Non-locating bearing

- Split bearing in associated housing has restricted usability. Please ask for further information.
- Alternatively also available with split labyrinth seal NTSG.
- With NTSG: width g_L increased by 16 mm.
- With NTSG: width g_{LD} increased by 8 mm.

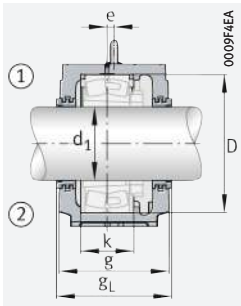

Labyrinth seal NTS

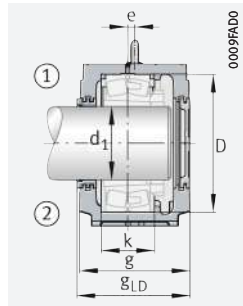

Labyrinth seal NTS
Cover NDK

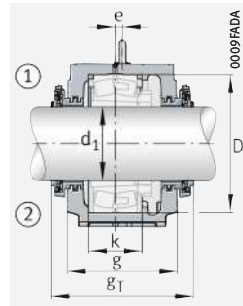

Taconite seal NTC

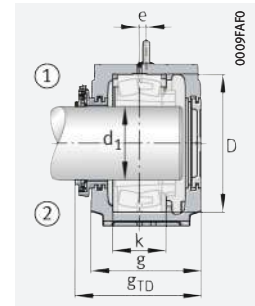

Taconite seal NTC
Cover NDK

Spherical roller bearings and accessories

Bearing	Adapter sleeve	Locating ring		Labyrinth seal			Taconite seal			Cover
			Quantity	\varnothing_L mm	\varnothing_{LD} mm		\varnothing_T mm	\varnothing_{TD} mm		
22326..-K	H2326	NFR280/7,5	2	NTS34/115	241	235,5	NTC34/115	299	264	NDK34
22328..-K	H2328	NFR300/7	2	NTS36/125	251	245,5	NTC36/125	310	274,5	NDK36
22330..-K	H2330	NFR320/8	2	NTS38/135	271	265,5	NTC38/135	330	294,5	NDK38
22232..-K	H3132(-HG)	NFR290/17,5	2	NTS38/140	251	245,5	NTC38/140	312	275,5	NDK38
22332..-K	H2332(-HG)	NFR340/9	2	NTS40/140	291	285,5	NTC40/140	347	313	NDK40
23232..-K	H2332(-HG)	NFR290/5,5	2	NTS38/140	251	245,5	NTC38/140	312	275,5	NDK38
22234..-K	H3134(-HG)	NFR310/18	2	NTS40/150	271	265,5	NTC40/150	326	293	NDK40
22334..-K	H2334(-HG)	NFR360/10	2	NTS48/150	301	295,5	NTC48/150	380	335	NDK48
23134..-K	H3134(-HG)	NFR280/10	2	NTS34 ²⁾	241 ³⁾	235,5 ⁴⁾	NTC34	299	264,5	NDK34
231SM150-MA ¹⁾	–	NFR280/10	2	NTS34 ²⁾	241 ³⁾	235,5 ⁴⁾	NTC34	299	264,5	NDK34
23234..-K	H2334(-HG)	NFR310/6	2	NTS40/150	271	265,5	NTC40/150	327	293	NDK40
22236..-K	H3136(-HG)	NFR320/19	2	NTS38/160	271	265,5	NTC38/160	329	294,5	NDK38
23036..-K	H3036(-HG)	NFR280/17	2	NTS36 ²⁾	241 ³⁾	235,5 ⁴⁾	NTC36	304	267	NDK36
230SM160-MA ¹⁾	–	NFR280/17	2	NTS36 ²⁾	241 ³⁾	235,5 ⁴⁾	NTC36	304	267	NDK36
23136..-K	H3136(-HG)	NFR300/10	2	NTS36 ²⁾	251 ³⁾	245,5 ⁴⁾	NTC36	314	277	NDK36
231SM160-MA ¹⁾	–	NFR300/10	2	NTS36 ²⁾	251 ³⁾	245,5 ⁴⁾	NTC36	314	277	NDK36
23236..-K	H2336(-HG)	NFR320/6	2	NTS38/160	271	265,5	NTC38/160	330	294,5	NDK38
22238..-K	H3138(-HG)	NFR340/10	4	NTS40/170	291	285,5	NTC40/170	346	313	NDK40
22338..-K	H2338(-HG)	NFR400/8	2	NTS48/170	321	315,5	NTC48/170	401	355	NDK48
23038..-K	H3038(-HG)	NFR290/10	4	NTS38 ²⁾	251 ³⁾	245,5 ⁴⁾	NTC38	312	275,5	NDK38
230SM170-MA ¹⁾	–	NFR290/10	4	NTS38 ²⁾	251 ³⁾	245,5 ⁴⁾	NTC38	312	275,5	NDK38
23138..-K	H3138(-HG)	NFR320/10	2	NTS38 ²⁾	271 ³⁾	265,5 ⁴⁾	NTC38	334	297	NDK38
231SM170-MA	–	NFR320/10	2	NTS38 ²⁾	271 ³⁾	265,5 ⁴⁾	NTC38	334	297	NDK38
23238..-K	H2338(-HG)	NFR340/6	2	NTS40/170	291	285,5	NTC40/170	347	313	NDK40



Plummer block housings

SNS, split

For spherical roller bearings with tapered bore and adapter sleeve, metric shaft

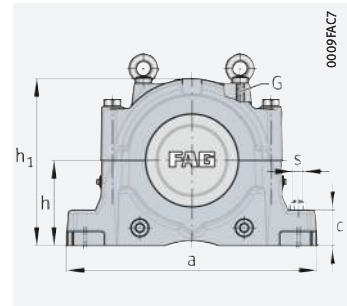
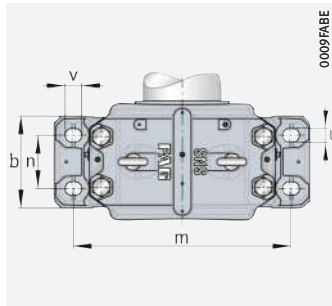

d₁ = 180 – 240 mm

Shaft d ₁	Housing Dimensions															Mass m ≈ kg	Housing Designation ▶ 1644 3.10
	h	h ₁	g	b	c	a	m	n	v	u	s	D	k	e	G		
180	220	434	290	240	90	640	540	140	42	35	M30	360	140	12	M20	148	SNS3048-H-D
	260	516	320	280	100	770	650	160	50	42	M36	420	166	13	M24	249	SNS3056-H-D
	190	375	260	210	80	560	480	120	34	28	M24	310	122	10	M20	105	SNS3040-H-D
	190	375	260	210	80	560	480	120	34	28	M24	310	122	10	M20	105	SNS3040-H-D
	210	411	280	230	85	610	510	130	42	35	M30	340	132	10	M20	133	SNS3140-H-D
	210	411	280	230	85	610	510	130	42	35	M30	340	132	10	M20	133	SNS3140-H-D
	220	434	290	240	90	640	540	140	42	35	M30	360	140	12	M20	148	SNS3240-H-D
200	240	474	310	260	95	700	600	150	42	35	M30	400	148	12	M24	184	SNS3148-H-D
	280	550	320	280	105	790	670	160	50	42	M36	460	166	16	M24	264	SNS3156-H-D
	210	411	280	230	85	610	510	130	42	35	M30	340	130	10	M20	129	SNS3044-H-D
	210	411	280	230	85	610	510	130	42	35	M30	340	130	10	M20	129	SNS3044-H-D
	220	434	290	240	90	640	540	140	42	35	M30	370	140	12	M20	146	SNS3144-H-D
	220	434	290	240	90	640	540	140	42	35	M30	370	140	12	M20	146	SNS3144-H-D
	240	474	310	260	95	700	600	150	42	35	M30	400	164	12	M24	183	SNS3244-H-D
220	260	516	320	280	100	770	650	160	50	42	M36	440	164	13	M24	238	SNS3152-H-D
	300	591	350	310	110	830	710	190	50	42	M36	500	180	22	M30	317	SNS3160-H-D
	220	434	290	240	90	640	540	140	42	35	M30	360	140	12	M20	148	SNS3048-H-D
	220	434	290	240	90	640	540	140	42	35	M30	360	140	12	M20	148	SNS3048-H-D
	240	474	310	260	95	700	600	150	42	35	M30	400	148	12	M24	184	SNS3148-H-D
	240	474	310	260	95	700	600	150	42	35	M30	400	148	12	M24	184	SNS3148-H-D
	260	516	320	280	100	770	650	160	50	42	M36	440	180	13	M24	235	SNS3248-H-D
240	300	591	350	310	110	830	710	190	50	42	M36	480	181	22	M30	332	SNS3064-H-D
	320	631	370	330	115	880	750	200	50	42	M36	540	196	23	M30	368	SNS3164-H-D
	240	474	310	260	95	700	600	150	42	35	M30	400	148	12	M24	180	SNS3052-H-D
	240	474	310	260	95	700	600	150	42	35	M30	400	148	12	M24	180	SNS3052-H-D
	260	516	320	280	100	770	650	160	50	42	M36	440	164	13	M24	238	SNS3152-H-D
	260	516	320	280	100	770	650	160	50	42	M36	440	164	13	M24	238	SNS3152-H-D
	300	591	350	310	110	830	710	190	50	42	M36	480	194	22	M30	331	SNS3252-H-D

medias ▶ <https://www.schaeffler.de/std/1F1B>

① Locating bearing; ② Non-locating bearing

- Split bearing in associated housing has restricted usability. Please ask for further information.
- Alternatively also available with split labyrinth seal NTSG.
- With NTSG: width g_L increased by 16 mm.
- With NTSG: width g_{LD} increased by 8 mm.

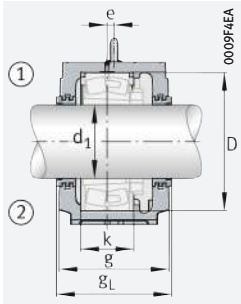

Labyrinth seal NTS

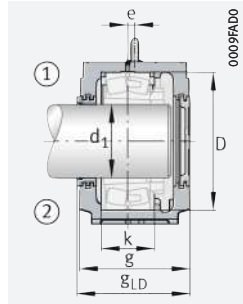

Labyrinth seal NTS
Cover NDK

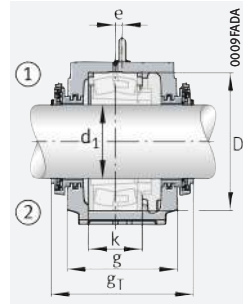

Taconite seal NTC

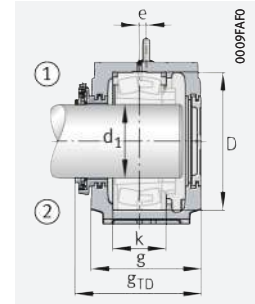

Taconite seal NTC
Cover NDK

Spherical roller bearings and accessories

Bearing	Adapter sleeve	Locating ring		Labyrinth seal			Taconite seal			Cover
			Quantity		g_L mm	g_{LD} mm		g_T mm	g_{TD} mm	
22240..-K	H3140(-HG)	NFR360/21	2	NTS48/180	301	295,5	NTC48/180	380	335	NDK48
22340..-K	H2340(-HG)	NFR420/14	2	NTS56/180	331	325,5	NTC56/180	411	365	NDK56
23040..-K	H3040(-HG)	NFR310/10	4	NTS40 ²⁾	271 ³⁾	265,5 ⁴⁾	NTC40	326	293	NDK40
2305M180-MA ¹⁾	–	NFR310/10	4	NTS40 ²⁾	271 ³⁾	265,5 ⁴⁾	NTC40	326	293	NDK40
23140..-K	H3140(-HG)	NFR340/10	2	NTS40 ²⁾	291 ³⁾	285,5 ⁴⁾	NTC40	354	317	NDK40
2315M180-MA	–	NFR340/10	2	NTS40 ²⁾	291 ³⁾	285,5 ⁴⁾	NTC40	354	317	NDK40
23240..-K	H2340(-HG)	NFR360/6	2	NTS48/180	301	295,5	NTC48/180	381	335	NDK48
22244..-K	H3144X(-HG)	NFR400/10	4	NTS48/200	321	315,5	NTC48/200	400	355	NDK48
22344..-K	H2344X(-HG)	NFR460/10,5	2	NTS56/200	331	325,5	NTC56/200	411	365	NDK56
23044..-K	H3044X(-HG)	NFR340/10	4	NTS44 ²⁾	291 ³⁾	285,5 ⁴⁾	NTC44	370	325	NDK44
2305M200-MA	–	NFR340/10	4	NTS44 ²⁾	291 ³⁾	285,5 ⁴⁾	NTC44	370	325	NDK44
23144..-K	H3144X(-HG)	NFR370/10	2	NTS44 ²⁾	301 ³⁾	295,5 ⁴⁾	NTC44	380	335	NDK44
2315M200-MA ¹⁾	–	NFR370/10	2	NTS44 ²⁾	301 ³⁾	295,5 ⁴⁾	NTC44	380	335	NDK44
23244..-K	H2344X(-HG)	NFR400/10	2	NTS48/200	321	315,5	NTC48/200	401	355	NDK48
22248..-K	H3148X(-HG)	NFR440/22	2	NTS52/220	331	325,5	NTC52/220	410	365	NDK52
22348..-K	H2348X(-HG)	NFR500/12,5	2	NTS60/220	361	355,5	NTC60/220	441	395	NDK60
23048..-K	H3048(-HG)	NFR360/12	4	NTS48 ²⁾	301 ³⁾	295,5 ⁴⁾	NTC48	380	335	NDK48
2305M220-MA ¹⁾	–	NFR360/12	4	NTS48 ²⁾	301 ³⁾	295,5 ⁴⁾	NTC48	380	335	NDK48
23148..-K	H3148X(-HG)	NFR400/10	2	NTS48 ²⁾	321 ³⁾	315,5 ⁴⁾	NTC48	400	355	NDK48
2315M220-MA	–	NFR400/10	2	NTS48 ²⁾	321 ³⁾	315,5 ⁴⁾	NTC48	400	355	NDK48
23248..-K	H2348X(-HG)	NFR440/10	2	NTS52/220	331	325,5	NTC52/220	410	365	NDK52
22252..-K	H3152X(-HG)	NFR480/25,5	2	NTS64/240	361	355,5	NTC64/240	440	395	NDK64
22352..-K	H2352X(-HG)	NFR540/15,5	2	NTS64/240	381	375,5	NTC64/240	460	415	NDK64
23052..-K	H3052X(-HG)	NFR400/22	2	NTS52 ²⁾	321 ³⁾	315,5 ⁴⁾	NTC52	401	355	NDK52
2305M240-MA	–	NFR400/22	2	NTS52 ²⁾	321 ³⁾	315,5 ⁴⁾	NTC52	401	355	NDK52
23152..-K	H3152X(-HG)	NFR440/10	2	NTS52 ²⁾	331 ³⁾	325,5 ⁴⁾	NTC52	410	365	NDK52
2315M240-MA ¹⁾	–	NFR440/10	2	NTS52 ²⁾	331 ³⁾	325,5 ⁴⁾	NTC52	410	365	NDK52
23252..-K	H2352X(-HG)	NFR480/10	2	NTS64/240	361	355,5	NTC64/240	440	395	NDK64





Plummer block housings

SNS, split

For spherical roller bearings with tapered bore and adapter sleeve, metric shaft

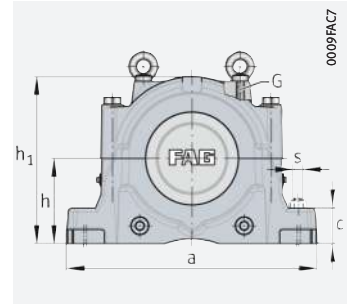
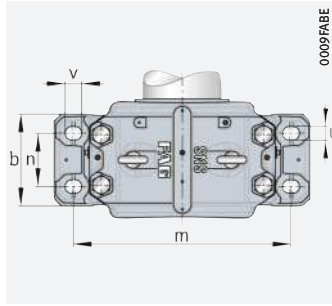

$d_1 = 260 - 320 \text{ mm}$

Shaft	Housing															Mass	Housing Designation
	Dimensions																
d_1	h	h_1	g	b	c	a	m	n	v	u	s	D	k	e	G	m	
260	300	591	350	310	110	830	710	190	50	42	M36	500	180	22	M30	317	SNS3160-H-D
	340	675	400	360	120	950	810	220	50	42	M36	580	210	24	M30	461	SNS3168-H-D
	260	516	320	280	100	770	650	160	50	42	M36	420	166	13	M24	249	SNS3056-H-D
	260	516	320	280	100	770	650	160	50	42	M36	420	166	13	M24	249	SNS3056-H-D
	280	550	320	280	105	790	670	160	50	42	M36	460	166	16	M24	264	SNS3156-H-D
	280	550	320	280	105	790	670	160	50	42	M36	460	166	16	M24	264	SNS3156-H-D
	300	591	350	310	110	830	710	190	50	42	M36	500	196	22	M30	314	SNS3256-H-D
	300	591	350	310	110	830	710	190	50	42	M36	500	196	22	M30	314	SNS3256-H-D
280	320	631	370	330	115	880	750	200	50	42	M36	540	196	23	M30	368	SNS3164-H-D
	280	550	320	280	105	790	670	160	50	42	M36	460	168	16	M24	260	SNS3060-H-D
	280	550	320	280	105	790	670	160	50	42	M36	460	168	16	M24	260	SNS3060-H-D
	300	591	350	310	110	830	710	190	50	42	M36	500	180	22	M30	317	SNS3160-H-D
	300	591	350	310	110	830	710	190	50	42	M36	500	180	22	M30	317	SNS3160-H-D
	320	631	370	330	115	880	750	200	50	42	M36	540	212	23	M30	364	SNS3260-H-D
300	340	675	400	360	120	950	810	220	50	42	M36	580	190	24	M30	466	SNS2264-H-D
	300	591	350	310	110	830	710	190	50	42	M36	480	181	22	M30	332	SNS3064-H-D
	300	591	350	310	110	830	710	190	50	42	M36	480	181	22	M30	332	SNS3064-H-D
	320	631	370	330	115	880	750	200	50	42	M36	540	196	23	M30	368	SNS3164-H-D
	320	631	370	330	115	880	750	200	50	42	M36	540	196	23	M30	368	SNS3164-H-D
	340	675	400	360	120	950	810	220	50	42	M36	580	228	24	M30	457	SNS3264-H-D
	340	675	400	360	120	950	810	220	50	42	M36	580	228	24	M30	457	SNS3264-H-D
	340	675	400	360	120	950	810	220	50	42	M36	580	228	24	M30	457	SNS3264-H-D
320	320	631	370	330	115	880	750	200	50	42	M36	520	197	23	M30	386	SNS3068-H-D
	320	631	370	330	115	880	750	200	50	42	M36	520	197	23	M30	386	SNS3068-H-D
	340	675	400	360	120	950	810	220	50	42	M36	580	210	24	M30	461	SNS3168-H-D
	340	675	400	360	120	950	810	220	50	42	M36	580	210	24	M30	461	SNS3168-H-D
	360	715	400	360	120	1040	870	220	50	42	M36	620	244	30	M36	530	SNS3268-H-D

medias ► <https://www.schaeffler.de/std/1F1C>

① Locating bearing; ② Non-locating bearing

1) Split bearing in associated housing has restricted usability. Please ask for further information.

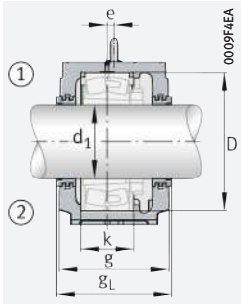

Labyrinth seal NTS

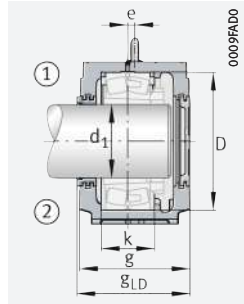

Labyrinth seal NTS
Cover NDK

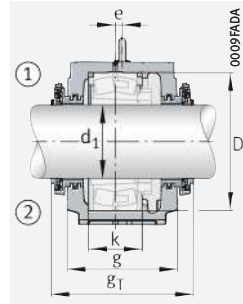

Taconite seal NTC

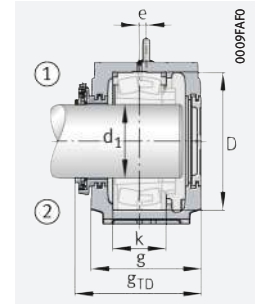

Taconite seal NTC
Cover NDK

Spherical roller bearings and accessories

Bearing	Adapter sleeve	Locating ring		Labyrinth seal			Taconite seal			Cover
			Quantity		g_L mm	g_{LD} mm		g_T mm	g_{TD} mm	
22256..-K	H3156X(-HG)	NFR500/25	2	NTS60/260	361	355,5	NTC60/260	440	395	NDK60
22356..-K	H2356X(-HG)	NFR580/17,5	2	NTS68/260	411	405,5	NTC68/260	490	445	NDK68
23056..-K	H3056(-HG)	NFR420/10	6	NTS56	331	325,5	NTC56	411	365	NDK56
230SM260-MA ¹⁾	–	NFR420/10	6	NTS56	331	325,5	NTC56	411	365	NDK56
23156..-K	H3156X(-HG)	NFR460/10	2	NTS56	331	325,5	NTC56	410	365	NDK56
231SM260-MA	–	NFR460/10	2	NTS56	331	325,5	NTC56	410	365	NDK56
23256..-K	H2356X(-HG)	NFR500/10	2	NTS60/260	361	355,5	NTC60/260	441	395	NDK60
232SM260-MA ¹⁾	–	NFR500/10	2	NTS60/260	361	355,5	NTC60/260	441	395	NDK60
22260..-K	H3160(-HG)	NFR540/28	2	NTS64/280	381	375,5	NTC64/280	460	415	NDK64
23060..-K	H3060(-HG)	NFR460/25	2	NTS60	331	325,5	NTC60	411	365	NDK60
230SM280-MA ¹⁾	–	NFR460/25	2	NTS60	331	325,5	NTC60	411	365	NDK60
23160..-K	H3160(-HG)	NFR500/10	2	NTS60	361	355,5	NTC60	440	395	NDK60
231SM280-MA ¹⁾	–	NFR500/10	2	NTS60	361	355,5	NTC60	440	395	NDK60
23260..-K	H3260(-HG)	NFR540/10	2	NTS64/280	381	375,5	NTC64/280	461	415	NDK64
22264..-K	H3164-HG	NFR580/20	2	NTS68/300	411	405,5	NTC68/300	490	445	NDK68
23064..-K	H3064-HG	NFR480/10	6	NTS64	361	355,5	NTC64	441	395	NDK64
230SM300-MA ¹⁾	–	NFR480/10	6	NTS64	361	355,5	NTC64	441	395	NDK64
23164..-K	H3164-HG	NFR540/10	2	NTS64	381	375,5	NTC64	460	415	NDK64
231SM300-MA ¹⁾	–	NFR540/10	2	NTS64	381	375,5	NTC64	460	415	NDK64
23264..-K	H3264-HG	NFR580/10	2	NTS68/300	411	405,5	NTC68/300	491	445	NDK68
232SM300-MA ¹⁾	–	NFR580/10	2	NTS68/300	411	405,5	NTC68/300	491	445	NDK68
23068..-K	H3068-HG	NFR520/16	4	NTS68	381	375,5	NTC68	461	415	NDK68
230SM320-MA ¹⁾	–	NFR520/16	4	NTS68	381	375,5	NTC68	461	415	NDK68
23168..-K	H3168-HG	NFR580/10	2	NTS68	411	405,5	NTC68	490	445	NDK68
231SM320-MA	–	NFR580/10	2	NTS68	411	405,5	NTC68	490	445	NDK68
23268..-K	H3268-HG	NFR620/10	2	NTS76/320	411	405,5	NTC76/320	490	445	NDK76



Plummer block housings

SNS, split

For spherical roller bearings with tapered bore and adapter sleeve, metric shaft

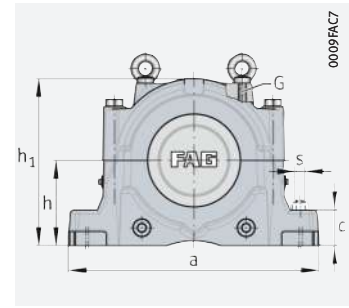
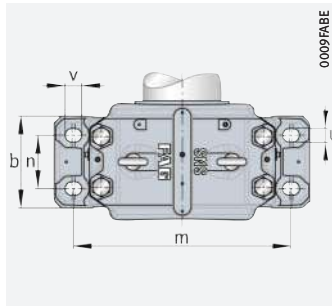

d₁ = 340 – 400 mm

Shaft d ₁	Housing Dimensions															Mass m ≈ kg	Housing Designation ▶ 1644 3.10
	h	h ₁	g	b	c	a	m	n	v	u	s	D	k	e	G		
340	380	755	430	390	125	1120	950	240	60	48	M42	650	220	30	M42	681	SNS3180-H-D
	320	631	370	330	115	880	750	200	50	42	M36	540	198	23	M30	356	SNS3072-H-D
	320	631	370	330	115	880	750	200	50	42	M36	540	198	23	M30	356	SNS3072-H-D
	350	695	400	360	120	1000	840	220	50	42	M36	600	212	30	M36	498	SNS3172-H-D
	350	695	400	360	120	1000	840	220	50	42	M36	600	212	30	M36	498	SNS3172-H-D
	380	755	430	390	125	1120	950	240	60	48	M42	650	252	30	M42	675	SNS3272-H-D
	380	755	430	390	125	1120	950	240	60	48	M42	650	252	30	M42	675	SNS3272-H-D
	360	340	675	400	360	120	950	810	220	50	42	M36	560	180	24	M30	481
340		675	400	360	120	950	810	220	50	42	M36	560	180	24	M30	481	SNS3076-H-D
360		715	400	360	120	1040	870	220	50	42	M36	620	214	30	M36	534	SNS3176-H-D
360		715	400	360	120	1040	870	220	50	42	M36	620	214	30	M36	534	SNS3176-H-D
410		810	460	420	130	1170	1000	260	60	48	M42	680	260	35	M42	841	SNS3276-H-D
380	350	695	400	360	120	1000	840	220	50	42	M36	600	192	30	M36	489	SNS3080-H-D
	350	695	400	360	120	1000	840	220	50	42	M36	600	192	30	M36	489	SNS3080-H-D
	380	755	430	390	125	1120	950	240	60	48	M42	650	220	30	M42	681	SNS3180-H-D
	380	755	430	390	125	1120	950	240	60	48	M42	650	220	30	M42	681	SNS3180-H-D
	420	835	460	430	135	1220	1030	260	60	48	M42	720	276	35	M42	895	SNS3280-H-D
400	360	715	400	360	120	1040	870	220	50	42	M36	620	194	30	M36	527	SNS3084-H-D
	360	715	400	360	120	1040	870	220	50	42	M36	620	194	30	M36	527	SNS3084-H-D
	410	810	460	420	130	1170	1000	260	60	48	M42	700	244	35	M42	821	SNS3184-H-D
	410	810	460	420	130	1170	1000	260	60	48	M42	700	244	35	M42	821	SNS3184-H-D
	440	880	470	440	145	1280	1070	260	60	48	M42	760	292	35	M48	984	SNS3284-H-D

medias ▶ <https://www.schaeffler.de/std/1F1D>

① Locating bearing; ② Non-locating bearing

1) Split bearing in associated housing has restricted usability. Please ask for further information.

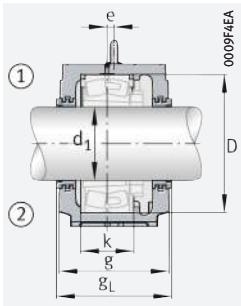

Labyrinth seal NTS

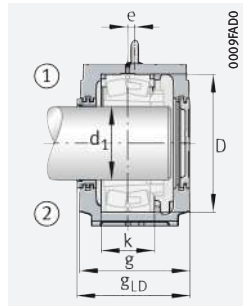

Labyrinth seal NTS
Cover NDK

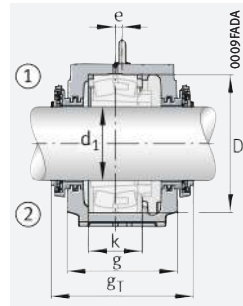

Taconite seal NTC

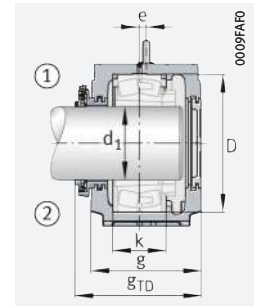

Taconite seal NTC
Cover NDK

Spherical roller bearings and accessories

Bearing	Adapter sleeve	Locating ring		Labyrinth seal			Taconite seal			Cover
			Quantity		\varnothing_L mm	\varnothing_{LD} mm		\varnothing_T mm	\varnothing_{TD} mm	
22272..-K	H3172-HG	NFR650/25	2	NTS80/340	441	435,5	NTC80/340	520	475	NDK80
23072..-K	H3072-HG	NFR540/16	4	NTS72	381	375,5	NTC72	461	415	NDK72
230SM340-MA¹⁾	–	NFR540/16	4	NTS72	381	375,5	NTC72	461	415	NDK72
23172..-K	H3172-HG	NFR600/10	2	NTS72	411	405,5	NTC72	490	445	NDK72
231SM340-MA¹⁾	–	NFR600/10	2	NTS72	411	405,5	NTC72	490	445	NDK72
23272..-K	H3272-HG	NFR650/10	2	NTS80/340	441	435,5	NTC80/340	520	475	NDK80
232SM340-MA¹⁾	–	NFR650/10	2	NTS80/340	441	435,5	NTC80/340	520	475	NDK80
23076..-K	H3076-HG	NFR560/22,5	2	NTS76	411	405,5	NTC76	491	445	NDK76
230SM360-MA	–	NFR560/22,5	2	NTS76	411	405,5	NTC76	491	445	NDK76
23176..-K	H3176-HG	NFR620/10	2	NTS76	411	405,5	NTC76	490	445	NDK76
231SM360-MA¹⁾	–	NFR620/10	2	NTS76	411	405,5	NTC76	490	445	NDK76
23276..-K	H3276-HG	NFR680/10	2	NTS92/360	471	465,5	NTC92/360	550	505	NDK92
23080..-K	H3080-HG	NFR600/22	2	NTS80	411	405,5	NTC80	491	445	NDK80
230SM380-MA¹⁾	–	NFR600/22	2	NTS80	411	405,5	NTC80	491	445	NDK80
23180..-K	H3180-HG	NFR650/10	2	NTS80	441	435,5	NTC80	520	475	NDK80
231SM380-MA¹⁾	–	NFR650/10	2	NTS80	441	435,5	NTC80	520	475	NDK80
23280..-K	H3280-HG	NFR720/10	2	NTS88/380	471	465,5	NTC88/380	550	505	NDK88
23084..-K	H3084X-HG	NFR620/22	2	NTS84	411	405,5	NTC84	491	445	NDK84
230SM400-MA¹⁾	–	NFR620/22	2	NTS84	411	405,5	NTC84	491	445	NDK84
23184..-K	H3184-HG	NFR700/10	2	NTS84	471	465,5	NTC84	550	505	NDK84
231SM400-MA	–	NFR700/10	2	NTS84	471	465,5	NTC84	550	505	NDK84
23284..-K	H3284-HG	NFR760/10	2	NTS92/400	481	475,5	NTC92/400	560	515	NDK92





Plummer block housings

SNS, split

For spherical roller bearings with tapered bore and adapter sleeve, metric shaft

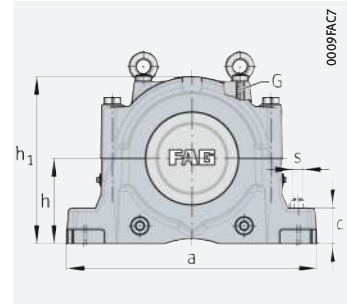
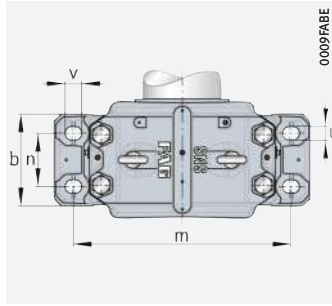

$d_1 = 410 - 500 \text{ mm}$

Shaft d_1	Housing Dimensions															Mass m ≈ kg	Housing Designation ▶ 1644 3.10
	h	h_1	g	b	c	a	m	n	v	u	s	D	k	e	G		
410	380	755	430	390	125	1 120	950	240	60	48	M42	650	200	30	M42	672	SNS3088-H-D
	380	755	430	390	125	1 120	950	240	60	48	M42	650	200	30	M42	672	SNS3088-H-D
	420	835	460	430	135	1 220	1 030	260	60	48	M42	720	246	35	M42	895	SNS3188-H-D
	420	835	460	430	135	1 220	1 030	260	60	48	M42	720	246	35	M42	895	SNS3188-H-D
	460	920	470	440	155	1 330	1 110	260	70	56	M48	790	300	35	M48	1 100	SNS3288-H-D
430	410	810	460	420	130	1 170	1 000	260	60	48	M42	680	224	35	M42	849	SNS3092-H-D
	440	880	470	440	145	1 280	1 070	260	60	48	M42	760	260	35	M48	993	SNS3192-H-D
450	410	810	460	420	130	1 170	1 000	260	60	48	M42	700	224	35	M42	806	SNS3096-H-D
	460	920	470	440	155	1 330	1 110	260	70	56	M48	790	268	35	M48	1 100	SNS3196-H-D
470	420	835	460	430	135	1 220	1 030	260	60	48	M42	720	226	35	M42	895	SNS30/500-H-D
500	460	920	470	440	155	1 330	1 110	260	70	56	M48	780	248	35	M48	1 100	SNS30/530-H-D

medias ▶ <https://www.schaeffler.de/std/1F1E>

① Locating bearing; ② Non-locating bearing

¹⁾ Split bearing in associated housing has restricted usability. Please ask for further information.

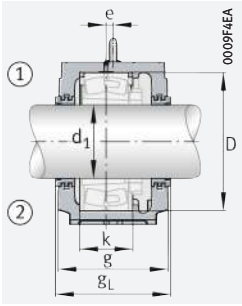

Labyrinth seal NTS

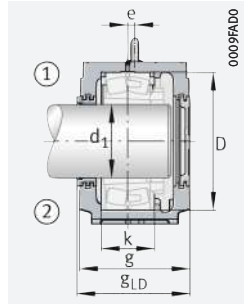

Labyrinth seal NTS
Cover NDK

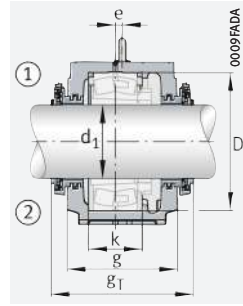

Taconite seal NTC

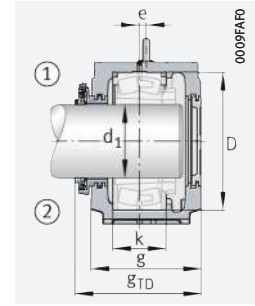

Taconite seal NTC
Cover NDK

Spherical roller bearings and accessories

Bearing	Adapter sleeve	Locating ring		Labyrinth seal			Taconite seal			Cover
			Quantity		g_L mm	g_{LD} mm		g_T mm	g_{TD} mm	
23088..-K	H3088-HG	NFR650/21,5	2	NTS88	441	435,5	NTC88	521	475	NDK88
230SM410-MA	-	NFR650/21,5	2	NTS88	441	435,5	NTC88	521	475	NDK88
23188..-K	H3188-HG	NFR720/10	2	NTS88	471	465,5	NTC88	550	505	NDK88
231SM410-MA¹⁾	-	NFR720/10	2	NTS88	471	465,5	NTC88	550	505	NDK88
23288..-K	H3288-HG	NFR790/10	2	NTS96/410	481	475,5	NTC96/410	560	515	NDK96
23092..-K	H3092-HG	NFR680/30,5	2	NTS92	471	465,5	NTC92	551	505	NDK92
23192..-K	H3192-HG	NFR760/10	2	NTS92	481	475,5	NTC92	560	515	NDK92
23096..-K	H3096-HG	NFR700/29,5	2	NTS96	471	465,5	NTC96	551	505	NDK96
23196..-K	H3196-HG	NFR790/10	2	NTS96	481	475,5	NTC96	560	515	NDK96
230/500..-K	H30/500-HG	NFR720/29,5	2	NTS500	471	465,5	NTC500	551	505	NDK500
230/530..-K	H30/530-HG	NFR780/31,5	2	NTS530	481	475,5	NTC530	561	515	NDK530



Plummer block housings

SNS, split
For spherical roller bearings with cylindrical bore, metric shaft

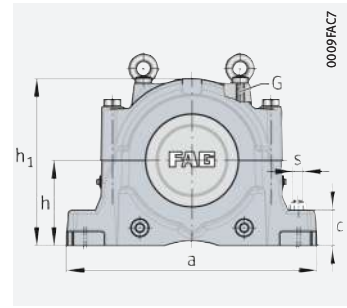
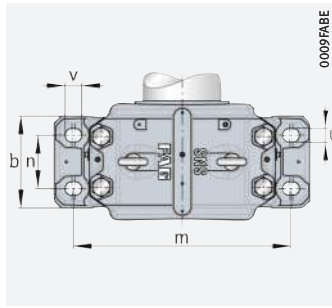

d = 130 – 200 mm

Shaft		Housing																Mass m ≈ kg	Housing Designation ▶ 1644 3.10
d	d ₂	Dimensions																	
		h	h ₁	g	b	c	a	m	n	v	u	s	D	k	e	G			
130	150	170	333	230	180	70	510	430	100	34	28	M24	280	108	14	M16	75	SNS3134-H-D	
140	160	180	353	240	190	75	530	450	110	34	28	M24	300	116	15	M16	83	SNS3136-H-D	
150	170	190	375	260	210	80	560	480	120	34	28	M24	320	124	10	M20	102	SNS3138-H-D	
160	180	180	353	240	190	75	530	450	110	34	28	M24	290	115	15	M16	86	SNS3038-H-D	
	180	210	411	280	230	85	610	510	130	42	35	M30	340	132	10	M20	133	SNS3140-H-D	
	180	180	353	240	190	75	530	450	110	34	28	M24	290	115	15	M16	86	SNS3038-H-D	
170	190	190	375	260	210	80	560	480	120	34	28	M24	310	122	10	M20	105	SNS3040-H-D	
	190	220	434	290	240	90	640	540	140	42	35	M30	360	140	12	M20	148	SNS3048-H-D	
	180	170	333	230	180	70	510	430	100	34	28	M24	280	108	14	M16	71	SNS3134-Z-D	
	190	190	375	260	210	80	560	480	120	34	28	M24	310	122	10	M20	105	SNS3234-Z-D	
180	200	190	375	260	210	80	560	480	120	34	28	M24	320	124	10	M20	97	SNS3138-Z-D	
	200	170	333	230	180	70	510	430	100	34	28	M24	280	108	14	M16	67	SNS3036-Z-D	
	200	180	353	240	190	75	530	450	110	34	28	M24	300	116	15	M16	77	SNS3136-Z-D	
	200	190	375	260	210	80	560	480	120	34	28	M24	320	124	10	M20	97	SNS3236-Z-D	
	200	170	333	230	180	70	510	430	100	34	28	M24	280	108	14	M16	67	SNS3036-Z-D	
190	210	210	411	280	230	85	610	510	130	42	35	M30	340	132	10	M20	125	SNS3140-Z-D	
	210	240	474	310	260	95	700	600	150	42	35	M30	400	148	12	M24	184	SNS3148-H-D	
	200	180	353	240	190	75	530	450	110	34	28	M24	290	115	15	M16	81	SNS3038-Z-D	
	200	190	375	260	210	80	560	480	120	34	28	M24	320	124	10	M20	97	SNS3138-Z-D	
	210	210	411	280	230	85	610	510	130	42	35	M30	340	132	10	M20	125	SNS3238-Z-D	
	200	180	353	240	190	75	530	450	110	34	28	M24	290	115	15	M16	81	SNS3038-Z-D	
200	220	220	434	290	240	90	640	540	140	42	35	M30	360	140	12	M20	148	SNS3048-H-D	
	220	190	375	260	210	80	560	480	120	34	28	M24	310	122	10	M20	97	SNS3040-Z-D	
	220	210	411	280	230	85	610	510	130	42	35	M30	340	132	10	M20	125	SNS3140-Z-D	
	220	220	434	290	240	90	640	540	140	42	35	M30	360	140	12	M20	148	SNS3240-Z-D	
	220	190	375	260	210	80	560	480	120	34	28	M24	310	122	10	M20	97	SNS3040-Z-D	

medias ▶ <https://www.schaeffler.de/std/1F1F>

① Locating bearing; ② Non-locating bearing

- 1) Alternatively also available with split labyrinth seal NTSG.
- 2) With NTSG: width g_L increased by 16 mm.
- 3) With NTSG: width g_{LD} increased by 8 mm.

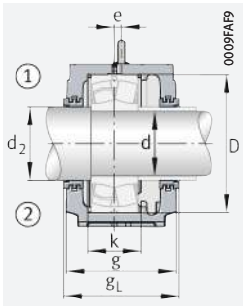

Labyrinth seal NTS

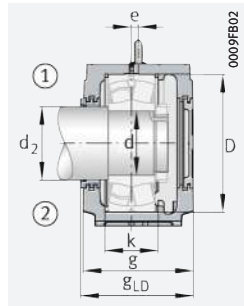

Labyrinth seal NTS
Cover NDK

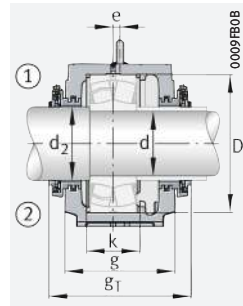

Taconite seal NTC

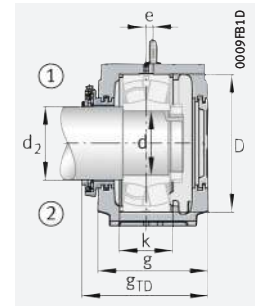

Taconite seal NTC
Cover NDK

Spherical roller bearings and accessories

Bearing	Locating ring		Labyrinth seal			Taconite seal			Cover
		Quantity		g _L mm	g _{LD} mm		g _T mm	g _{TD} mm	
22326	NFR280/7,5	2	NTS34 ¹⁾	241 ²⁾	235,5 ³⁾	NTC34	299	264,5	NDK34
22328	NFR300/7	2	NTS36 ¹⁾	251 ²⁾	245,5 ³⁾	NTC36	314	277	NDK36
22330	NFR320/8	2	NTS38 ¹⁾	271 ²⁾	265,5 ³⁾	NTC38	334	297	NDK38
22232	NFR290/17,5	2	NTS38/180	251	245,5	NTC38/180	314	277	NDK38
22332	NFR340/9	2	NTS40 ¹⁾	291 ²⁾	285,5 ³⁾	NTC40	354	317	NDK40
23232	NFR290/5,5	2	NTS38/180	251	245,5	NTC38/180	314	277	NDK38
22234	NFR310/18	2	NTS40/190	271	265,5	NTC40/190	334	297	NDK40
22334	NFR360/10	2	NTS48/190	301	295,5	NTC48/190	380	335	NDK48
23134	NFR280/10	2	NTS40 ¹⁾	241 ²⁾	235,5 ³⁾	NTC40	298	264	NDK40
23234	NFR310/6	2	NTS40/190	271	265,5	NTC40/190	326	293	NDK40
22236	NFR320/19	2	NTS44 ¹⁾	271 ²⁾	265,5 ³⁾	NTC44	350	305	NDK44
23036	NFR280/17	2	NTS44 ¹⁾	241 ²⁾	235,5 ³⁾	NTC44	320	275	NDK44
23136	NFR300/10	2	NTS44 ¹⁾	251 ²⁾	245,5 ³⁾	NTC44	330	285	NDK44
23236	NFR320/6	2	NTS44 ¹⁾	271 ²⁾	265,5 ³⁾	NTC44	350	305	NDK44
24036	NFR280/4	2	NTS44 ¹⁾	241 ²⁾	235,5 ³⁾	NTC44	320	275	NDK44
22238	NFR340/10	4	NTS48/210	291	285,5	NTC48/210	372	302,5	NDK48
22338	NFR400/8	2	NTS48/210	321	315,5	NTC48/210	402	329,5	NDK48
23038	NFR290/10	4	NTS44 ¹⁾	251 ²⁾	245,5 ³⁾	NTC44	330	285	NDK44
23138	NFR320/10	2	NTS44 ¹⁾	271 ²⁾	265,5 ³⁾	NTC44	350	305	NDK44
23238	NFR340/6	2	NTS48/210	291	285,5	NTC48/210	372	302,5	NDK48
24038	NFR290/7,5	2	NTS44 ¹⁾	251 ²⁾	245,5 ³⁾	NTC44	330	285	NDK44
22240	NFR360/21	2	NTS48 ¹⁾	301 ²⁾	295,5 ³⁾	NTC48	380	335	NDK48
23040	NFR310/10	4	NTS48 ¹⁾	271 ²⁾	265,5 ³⁾	NTC48	350	305	NDK48
23140	NFR340/10	2	NTS48 ¹⁾	291 ²⁾	285,5 ³⁾	NTC48	372	302,5	NDK48
23240	NFR360/6	2	NTS48 ¹⁾	301 ²⁾	295,5 ³⁾	NTC48	380	335	NDK48
24040	NFR310/6,5	2	NTS48 ¹⁾	271 ²⁾	265,5 ³⁾	NTC48	350	305	NDK48



Plummer block housings

SNS, split
For spherical roller bearings with cylindrical bore, metric shaft

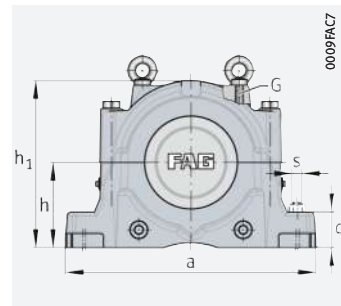
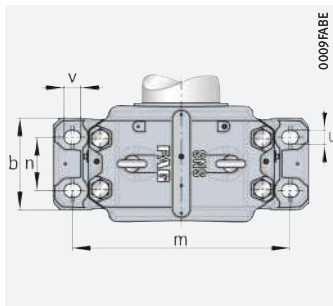

d = 220 – 280 mm

Shaft		Housing															Mass m ≈ kg	Housing Designation ▶ 1644 3.10	
d	d ₂	Dimensions													D	k			e
		h	h ₁	g	b	c	a	m	n	v	u	s							
220	240	240	474	310	260	95	700	600	150	42	35	M30	400	148	12	M24	176	SNS3148-Z-D	
	240	280	550	320	280	105	790	670	160	50	42	M36	460	166	16	M24	264	SNS3156-H-D	
	240	210	411	280	230	85	610	510	130	42	35	M30	340	130	10	M20	121	SNS3044-Z-D	
	240	220	434	290	240	90	640	540	140	42	35	M30	370	140	12	M20	138	SNS3144-Z-D	
	240	240	474	310	260	95	700	600	150	42	35	M30	400	164	12	M24	174	SNS3244-Z-D	
	240	210	411	280	230	85	610	510	130	42	35	M30	340	130	10	M20	121	SNS3044-Z-D	
240	260	260	516	320	280	100	770	650	160	50	42	M36	440	164	13	M24	229	SNS3152-Z-D	
	260	300	591	350	310	110	830	710	190	50	42	M36	500	180	22	M30	317	SNS3160-H-D	
	260	220	434	290	240	90	640	540	140	42	35	M30	360	140	12	M20	140	SNS3048-Z-D	
	260	240	474	310	260	95	700	600	150	42	35	M30	400	148	12	M24	176	SNS3148-Z-D	
	260	260	516	320	280	100	770	650	160	50	42	M36	440	180	13	M24	226	SNS3248-Z-D	
	260	220	434	290	240	90	640	540	140	42	35	M30	360	140	12	M20	140	SNS3048-Z-D	
260	280	300	591	350	310	110	830	710	190	50	42	M36	480	181	22	M30	332	SNS3064-H-D	
	290	320	631	370	330	115	880	750	200	50	42	M36	540	196	23	M30	368	SNS3164-H-D	
	280	240	474	310	260	95	700	600	150	42	35	M30	400	148	12	M24	171	SNS3052-Z-D	
	280	260	516	320	280	100	770	650	160	50	42	M36	440	164	13	M24	229	SNS3152-Z-D	
	280	300	591	350	310	110	830	710	190	50	42	M36	480	194	22	M30	331	SNS3252-Z-D	
	280	240	474	310	260	95	700	600	150	42	35	M30	400	148	12	M24	171	SNS3052-Z-D	
280	300	300	591	350	310	110	830	710	190	50	42	M36	500	180	22	M30	307	SNS3160-Z-D	
	310	340	675	400	360	120	950	810	220	50	42	M36	580	210	24	M30	461	SNS3168-H-D	
	300	260	516	320	280	100	770	650	160	50	42	M36	420	166	13	M24	240	SNS3056-Z-D	
	300	280	550	320	280	105	790	670	160	50	42	M36	460	166	16	M24	255	SNS3156-Z-D	
	300	300	591	350	310	110	830	710	190	50	42	M36	500	196	22	300	591	SNS3256-Z-D	
	300	260	516	320	280	100	770	650	160	50	42	M36	420	166	13	M24	240	SNS3056-Z-D	

medias ▶ <https://www.schaeffler.de/std/1F20>

① Locating bearing; ② Non-locating bearing

- 1) Alternatively also available with split labyrinth seal NTSG.
- 2) With NTSG: width g_L increased by 16 mm.
- 3) With NTSG: width g_{LD} increased by 8 mm.

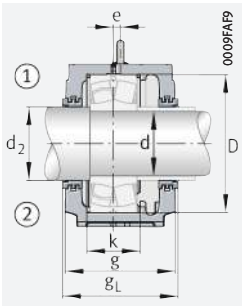

Labyrinth seal NTS

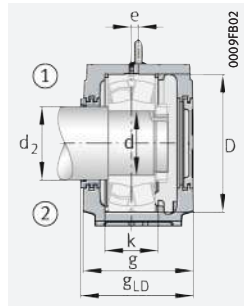

Labyrinth seal NTS
Cover NDK

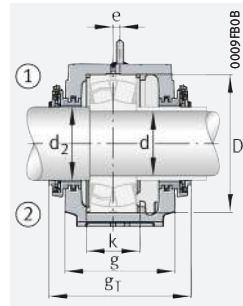

Taconite seal NTC

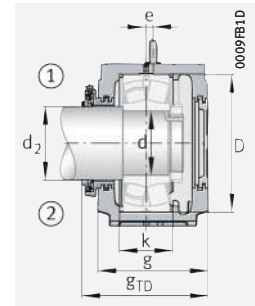

Taconite seal NTC
Cover NDK

Spherical roller bearings and accessories

Bearing	Locating ring		Labyrinth seal			Taconite seal			Cover
		Quantity		g _L mm	g _{LD} mm		g _T mm	g _{TD} mm	
22244	NFR400/10	4	NTS56/240	321	315,5	NTC56/240	400	355	NDK56
22344	NFR460/10,5	2	NTS56/240	331	325,5	NTC56/240	410	365	NDK56
23044	NFR340/10	4	NTS52 ¹⁾	291 ²⁾	285,5 ³⁾	NTC52	370	325	NDK52
23144	NFR370/10	2	NTS52 ¹⁾	301 ²⁾	295,5 ³⁾	NTC52	380	335	NDK52
23244	NFR400/10	2	NTS56/240	321	315,5	NTC56/240	400	355	NDK56
24044	NFR340/6	2	NTS52 ¹⁾	291 ²⁾	285,5 ³⁾	NTC52	370	325	NDK52
22248	NFR440/22	2	NTS60/260	331	325,5	NTC60/260	410	365	NDK60
22348	NFR500/12,5	2	NTS60/260	361	355,5	NTC60/260	440	395	NDK60
23048	NFR360/12	4	NTS56	301	295,5	NTC56	380	335	NDK56
23148	NFR400/10	2	NTS56	321	315,5	NTC56	400	355	NDK56
23248	NFR440/10	2	NTS60/260	331	325,5	NTC60/260	410	365	NDK60
24048	NFR360/11	2	NTS56	301	295,5	NTC56	380	335	NDK56
22252	NFR480/25,5	2	NTS64/280	361	355,5	NTC64/280	440	395	NDK64
22352	NFR540/15,5	2	NTS64/290	381	375,5	NTC64/290	460	415	NDK64
23052	NFR400/22	2	NTS60	321	315,5	NTC60	400	355	NDK60
23152	NFR440/10	2	NTS60	331	325,5	NTC60	410	365	NDK60
23252	NFR480/10	2	NTS64/280	361	355,5	NTC64/280	440	395	NDK64
24052	NFR400/4	2	NTS60	321	315,5	NTC60	400	355	NDK60
22256	NFR500/25	2	NTS68/300	361	355,5	NTC68/300	440	395	NDK68
22356	NFR580/17,5	2	NTS68/310	411	405,5	NTC68/310	490	445	NDK68
23056	NFR420/10	6	NTS64	331	325,5	NTC64	410	365	NDK64
23156	NFR460/10	2	NTS64	331	325,5	NTC64	410	365	NDK64
23256	NFR500/10	2	NTS68/300	361	355,5	NTC68/300	440	395	NDK68
24056	NFR420/13	2	NTS64	331	325,5	NTC64	410	365	NDK64





Plummer block housings

SNS, split
For spherical roller bearings with cylindrical bore, metric shaft

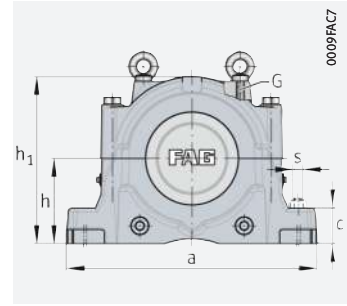
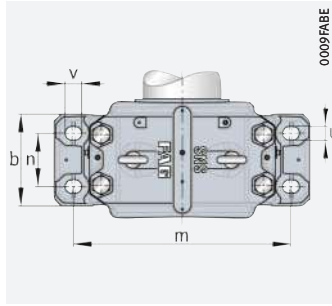

d = 300 – 380 mm

Shaft		Housing															Mass m ≈ kg	Housing Designation ▶ 1644 3.10
d	d ₂	Dimensions													h	g		
		h	h ₁	g	b	c	a	m	n	v	u	s	D	k	e	G		
300	320	320	631	370	330	115	880	750	200	50	42	M36	540	196	23	M30	357	SNS3164-Z-D
	320	280	550	320	280	105	790	670	160	50	42	M36	460	168	16	M24	249	SNS3060-Z-D
	320	300	591	350	310	110	830	710	190	50	42	M36	500	180	22	M30	307	SNS3160-Z-D
	320	320	631	370	330	115	880	750	200	50	42	M36	540	212	23	M30	353	SNS3260-Z-D
	320	280	550	320	280	105	790	670	160	50	42	M36	460	168	16	M24	249	SNS3060-Z-D
320	340	340	675	400	360	120	950	810	220	50	42	M36	580	190	24	M30	455	SNS2264-Z-D
	340	300	591	350	310	110	830	710	190	50	42	M36	480	181	22	M30	321	SNS3064-Z-D
	340	320	631	370	330	115	880	750	200	50	42	M36	540	196	23	M30	357	SNS3164-Z-D
	340	340	675	400	360	120	950	810	220	50	42	M36	580	228	24	M30	445	SNS3264-Z-D
	340	300	591	350	310	110	830	710	190	50	42	M36	480	181	22	M30	321	SNS3064-Z-D
340	360	320	631	370	330	115	880	750	200	50	42	M36	520	197	23	M30	374	SNS3068-Z-D
	360	340	675	400	360	120	950	810	220	50	42	M36	580	210	24	M30	450	SNS3168-Z-D
	370	360	715	400	360	120	1040	870	220	50	42	M36	620	244	30	M36	530	SNS3268-Z-D
	360	320	631	370	330	115	880	750	200	50	42	M36	520	197	23	M30	374	SNS3068-Z-D
360	390	380	755	430	390	125	1120	950	240	60	48	M42	650	220	30	M42	681	SNS3180-H-D
	380	320	631	370	330	115	880	750	200	50	42	M36	540	198	23	M30	344	SNS3072-Z-D
	380	350	695	400	360	120	1000	840	220	50	42	M36	600	212	30	M36	486	SNS3172-Z-D
	390	380	755	430	390	125	1120	950	240	60	48	M42	650	252	30	M42	675	SNS3272-Z-D
	380	320	631	370	330	115	880	750	200	50	42	M36	540	198	23	M30	344	SNS3072-Z-D
380	400	340	675	400	360	120	950	810	220	50	42	M36	560	180	24	M30	467	SNS3076-Z-D
	400	360	715	400	360	120	1040	870	220	50	42	M36	620	214	30	M36	521	SNS3176-Z-D
	410	410	810	460	420	130	1170	1000	260	60	48	M42	680	260	35	M42	841	SNS3276-Z-D
	400	340	675	400	360	120	950	810	220	50	42	M36	560	200	24	M30	465	SNS4076-Z-D

medias ▶ <https://www.schaeffler.de/std/1F21>

① Locating bearing; ② Non-locating bearing

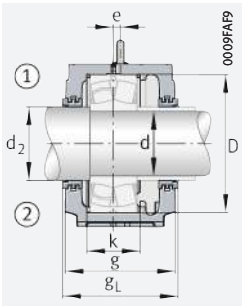

Labyrinth seal NTS

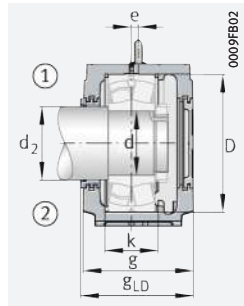

Labyrinth seal NTS
Cover NDK

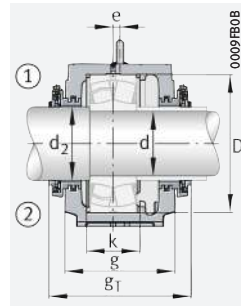

Taconite seal NTC

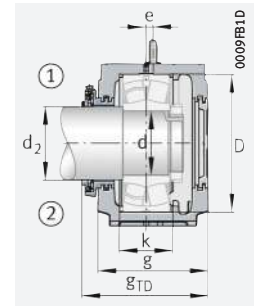

Taconite seal NTC
Cover NDK

Spherical roller bearings and accessories

Bearing	Locating ring		Labyrinth seal			Taconite seal			Cover
		Quantity		g _L mm	g _{LD} mm		g _T mm	g _{TD} mm	
22260	NFR540/28	2	NTS72/320	381	375,5	NTC72/320	460	415	NDK72
23060	NFR460/25	2	NTS68	331	325,5	NTC68	410	365	NDK68
23160	NFR500/10	2	NTS68	361	355,5	NTC68	440	395	NDK68
23260	NFR540/10	2	NTS72/320	381	375,5	NTC72/320	460	415	NDK72
24060	NFR460/4	2	NTS68	331	325,5	NTC68	410	365	NDK68
22264	NFR580/20	2	NTS76/340	411	405,5	NTC76/340	490	445	NDK76
23064	NFR480/10	6	NTS72	361	355,5	NTC72	440	395	NDK72
23164	NFR540/10	2	NTS72	381	375,5	NTC72	460	415	NDK72
23264	NFR580/10	2	NTS76/340	411	405,5	NTC76/340	490	445	NDK76
24064	NFR480/10,5	2	NTS72	361	355,5	NTC72	440	395	NDK72
23068	NFR520/16	4	NTS76	381	375,5	NTC76	460	415	NDK76
23168	NFR580/10	2	NTS76	411	405,5	NTC76	490	445	NDK76
23268	NFR620/10	2	NTS76/370	411	405,5	NTC76/370	490	445	NDK76
24068	NFR520/8,5	2	NTS76	381	375,5	NTC76	460	415	NDK76
22272	NFR650/25	2	NTS80/390	441	435,5	NTC80/390	520	475	NDK80
23072	NFR540/16	4	NTS80	381	375,5	NTC80	460	415	NDK80
23172	NFR600/10	2	NTS80	411	405,5	NTC80	490	445	NDK80
23272	NFR650/10	2	NTS80/390	441	435,5	NTC80/390	520	475	NDK80
24072	NFR540/9	2	NTS80	381	375,5	NTC80	460	415	NDK80
23076	NFR560/22,5	2	NTS84	411	405,5	NTC84	490	445	NDK84
23176	NFR620/10	2	NTS84	411	405,5	NTC84	490	445	NDK84
23276	NFR680/10	2	NTS92/410	471	465,5	NTC92/410	550	505	NDK92
24076	NFR560/10	2	NTS84	411	405,5	NTC84	475	438	NDK84





Plummer block housings

SNS, split
For spherical roller bearings with cylindrical bore, metric shaft

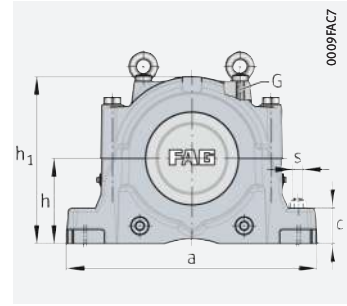
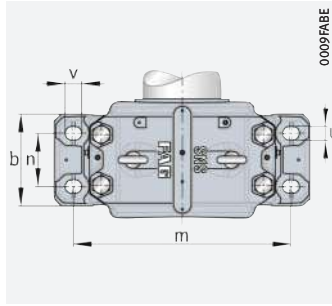

d = 400 – 530 mm

Shaft		Housing																Mass m ≈ kg	Housing Designation ▶ 1644 3.10
d	d ₂	Dimensions																	
		h	h ₁	g	b	c	a	m	n	v	u	s	D	k	e	G			
400	430	350	695	400	360	120	1000	840	220	50	42	M36	600	192	30	M36	468	SNS3080-Z-D	
	430	380	755	430	390	125	1120	950	240	60	48	M42	650	220	30	M42	660	SNS3180-Z-D	
	430	420	835	460	430	135	1220	1030	260	60	48	M42	720	276	35	M42	895	SNS3280-Z-D	
	430	350	695	400	360	120	1000	840	220	50	42	M36	600	220	30	M36	463	SNS4080-Z-D	
420	450	360	715	400	360	120	1040	870	220	50	42	M36	620	194	30	M36	505	SNS3084-Z-D	
	450	410	810	460	420	130	1170	1000	260	60	48	M42	700	244	35	M42	799	SNS3184-Z-D	
	460	440	880	470	440	145	1280	1070	260	60	48	M42	760	292	35	M48	956	SNS3284-Z-D	
	450	360	715	400	360	120	1040	870	220	50	42	M36	620	220	30	M36	499	SNS4084-Z-D	
440	470	380	755	430	390	125	1120	950	240	60	48	M42	650	200	30	M42	649	SNS3088-Z-D	
	470	420	835	460	430	135	1220	1030	260	60	48	M42	720	246	35	M42	895	SNS3188-Z-D	
	480	460	920	470	440	155	1330	1110	260	70	56	M48	790	300	35	M48	1100	SNS3288-Z-D	
	470	380	755	430	390	125	1120	950	240	60	48	M42	650	232	30	M42	642	SNS4088-Z-D	
460	500	410	810	460	420	130	1170	1000	260	60	48	M42	680	224	35	M42	821	SNS3092-Z-D	
	500	440	880	470	440	145	1280	1070	260	60	48	M42	760	260	35	M48	966	SNS3192-Z-D	
	500	410	810	460	420	130	1170	1000	260	60	48	M42	680	238	35	M42	818	SNS4092-Z-D	
480	510	410	810	460	420	130	1170	1000	260	60	48	M42	700	224	35	M42	786	SNS3096-Z-D	
	520	460	920	470	440	155	1330	1110	260	70	56	M48	790	268	35	M48	1100	SNS3196-Z-D	
	510	410	810	460	420	130	1170	1000	260	60	48	M42	700	238	35	M42	780	SNS4096-Z-D	
500	530	420	835	460	430	135	1220	1030	260	60	48	M42	720	226	35	M42	895	SNS30/500-Z-D	
	530	420	835	460	430	135	1220	1030	260	60	48	M42	720	238	35	M42	895	SNS40/500-Z-D	
530	560	460	920	470	440	155	1330	1110	260	70	56	M48	780	248	35	M48	1100	SNS30/530-Z-D	
	560	460	920	470	440	155	1330	1110	260	70	56	M48	780	270	35	M48	1100	SNS40/530-Z-D	

medias ▶ <https://www.schaeffler.de/std/1F22>

① Locating bearing; ② Non-locating bearing

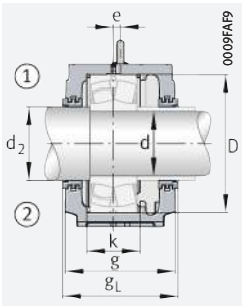

Labyrinth seal NTS

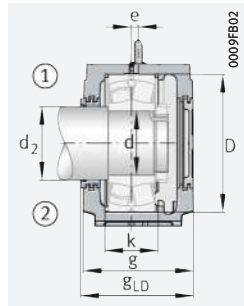

Labyrinth seal NTS
Cover NDK

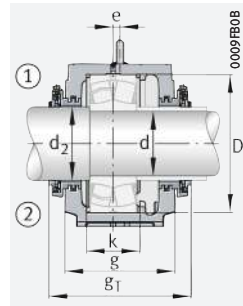

Taconite seal NTC

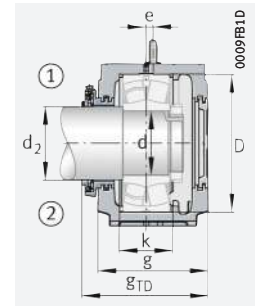

Taconite seal NTC
Cover NDK

Spherical roller bearings and accessories

Bearing	Locating ring	Quantity	Labyrinth seal			Taconite seal			Cover
				g _L mm	g _{LD} mm		g _T mm	g _{TD} mm	
23080	NFR600/22	2	NTS92	411	405,5	NTC92	490	445	NDK92
23180	NFR650/10	2	NTS92	441	435,5	NTC92	520	475	NDK92
23280	NFR720/10	2	NTS500/430	471	465,5	NTC500/430	550	505	NDK500
24080	NFR600/10	2	NTS92	411	405,5	NTC92	475	438	NDK92
23084	NFR620/22	2	NTS96	411	405,5	NTC96	490	445	NDK96
23184	NFR700/10	2	NTS96	471	465,5	NTC96	550	505	NDK96
23284	NFR760/10	2	NTS530/460	481	475,5	NTC530/460	560	515	NDK530
24084	NFR620/10	2	NTS96	411	405,5	NTC96	475	438	NDK96
23088	NFR650/21,5	2	NTS500	441	435,5	NTC500	520	475	NDK500
23188	NFR720/10	2	NTS500	471	465,5	NTC500	550	505	NDK500
23288	NFR790/10	2	NTS560/480	481	475,5	NTC560/480	560	515	NDK560
24088	NFR650/10	2	NTS500	441	435,5	NTC500	505	468	NDK500
23092	NFR680/30,5	2	NTS530	471	465,5	NTC530	550	505	NDK530
23192	NFR760/10	2	NTS530	481	475,5	NTC530	560	515	NDK530
24092	NFR680/10	2	NTS530	471	465,5	NTC530	535	498	NDK530
23096	NFR700/29,5	2	NTS530/510	471	465,5	NTC530/510	550	505	NDK530
23196	NFR790/10	2	NTS560/520	481	475,5	NTC560/520	560	515	NDK560
24096	NFR700/10	2	NTS530/510	471	465,5	NTC530/510	535	498	NDK530
230/500	NFR720/29,5	2	NTS560	471	465,5	NTC560	550	505	NDK560
240/500	NFR720/10	2	NTS560	471	465,5	NTC560	535	498	NDK560
230/530	NFR780/31,5	2	NTS600	481	475,5	NTC600	560	515	NDK600
240/530	NFR780/10	2	NTS600	481	475,5	NTC600	545	508	NDK600



4 Other bearing housings

4.1 Split plummer block housings S30

Housings for wide range of applications

Split plummer block housings S30 can be used for various applications, such as sintering and pelletising equipment as well as paper processing machinery 1668 1.

1
 Split plummer block housings S30



Shaft diameters from 110 mm to 150 mm

Suitable bearings
 The dimensions of split plummer block housings S30 are matched to spherical roller bearings 230 and toroidal roller bearings C30 1668 1. The range of shaft diameters is between 110 mm and 150 mm.

1
 Bearing type and sizes

Bearing type	Size
Spherical roller bearings	23024...-K to 23034...-K
■ with tapered bore and adapter sleeve	
■ with cylindrical bore	23024 to 23034
Toroidal roller bearings	C3022...-K to C3034...-K
■ with tapered bore and adapter sleeve	
■ with cylindrical bore	C3022 to C3034

Split spherical roller bearings

Unsplit spherical roller bearings with an adapter sleeve can be replaced by split spherical roller bearings. This gives a considerable reduction in the work associated with bearing replacement in numerous applications. In order to ensure selection of the correct combination of housing and bearing when using split bearings, please contact Schaeffler.



The range of split spherical roller bearings is described in detail in a separate publication TPI 250.

Flake graphite cast iron as standard

Materials
 Material for housing body:

- flake graphite cast iron (standard)
- spheroidal graphite cast iron
- cast steel.

🔧 *Locating bearing arrangement by means of locating ring*

Locating and non-locating bearings

The bearing seats in the housing are machined such that the bearings are movable in the housing and can thus function as non-locating bearings. Locating bearing arrangements can be achieved by the insertion of a locating ring FRM adjacent to the bearing outer ring.

🔧 *Grease lubrication*

Lubrication

Suitable lubrication method:
 ■ grease lubrication.

🔧 *Felt seals*

Sealing

Plummer block housings S30 are sealed by means of felt seals ▶ 1669 | 2. The felt seals allow shaft misalignment of up to 0,5° in both directions and are suitable for grease lubrication.

The oil-soaked felt strips must be inserted in the associated slots in the housing. In the case of a housing closed on one side, 2 felt strips are inserted, while 4 felt strips are necessary in the case of a continuous shaft.

2
 Felt seal for plummer block housing S30

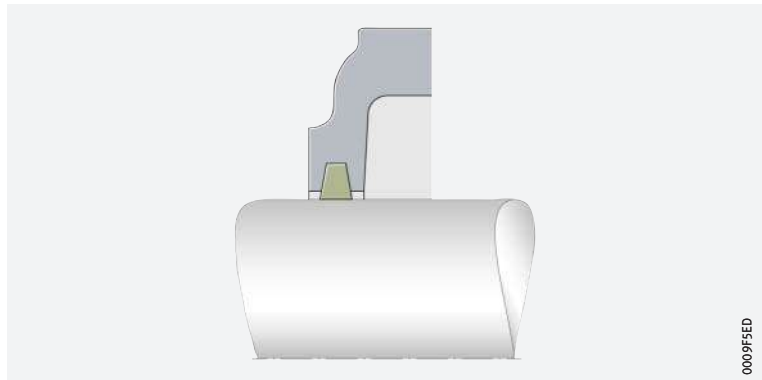

🔧 *Covers DK made from polyamide*

In the case of a housing closed on one side, a cover DK is inserted in the slots can be inserted instead of the felt strips on one side of the housing. Covers DK are made from polyamide.

Scope of delivery

When ordering split plummer block housings S30, the housing designation only describes the housing body. The felt strips for sealing the housing are included in the scope of delivery, while the cover and locating rings must be ordered separately. The rolling bearing and, if necessary, the adapter sleeve must also be ordered separately.

Further information



Detailed information on split plummer block housings S30: Bearing Housings ▶ GK 1.



4.2 Split plummer block housings SAF

Housing dimensions for inch size shaft centre heights

Split plummer block housings SAF and the associated bearings form bearing arrangement units that can be matched, through the appropriate selection of accessories, to a wide range of applications. The housings are specifically designed for inch size shaft centre heights \blacktriangleright 1670 |  3.

 3
 Split plummer block housings SAF



Shaft diameters from 1 3/8 inch to 8 inch

Suitable bearings

The dimensions of split plummer block housings SAF are matched to spherical roller bearings 222..-K \blacktriangleright 1670 |  2. The range of shaft diameters is between 1 3/8 inch and 8 inch.

 2
 Bearing type and sizes

Bearing type	Size
Spherical roller bearings  with tapered bore and adapter sleeve	22209..-K to 22244..-K

Split spherical roller bearings

In the replacement of bearings, the unsplit spherical roller bearings can be replaced by split spherical roller bearings 222S. This gives a considerable reduction in the work associated with bearing replacement in numerous applications.



In order to ensure selection of the correct combination of housing and bearing when using split bearings, please contact Schaeffler.





The range of split spherical roller bearings is described in detail in a separate publication \blacktriangleright  TPI 250.

Flake graphite cast iron as standard

Materials

Material for housing body:

-  flake graphite cast iron to ASTM A48 Class 35 (standard)
-  spheroidal graphite cast iron to ASTM A536 Grade 65-45-12.

The colour of the paint coating on housings made from flake graphite cast iron is grey (colour RAL 7016, anthracite grey), while on housings made from spheroidal graphite cast iron it is orange (colour RAL 2004, pure orange).

Locating bearing arrangement by means of locating ring

Locating and non-locating bearings

The bearing seats in the housing are machined such that the bearings are movable and can thus function as non-locating bearings. Locating bearing arrangements can be achieved by the insertion of a locating ring SR.

☞ Grease or oil lubrication

Lubrication

Suitable lubrication methods:

- grease lubrication
- oil lubrication.

Sealing

For sealing of the bearing housings, the standard seals available are the labyrinth seal and the taconite seal ► 1672 | 3. These seals are matched to the rectangular section annular slots on both sides of the housings.

☞ Labyrinth seals LER

Labyrinth seals LER give non-contact sealing. They are therefore suitable for high speeds. The O ring, which is pressed between the labyrinth ring and shaft, is made from NBR and is suitable for temperatures of up to +100 °C.

Labyrinth seals allow shaft misalignment of up to 0,3° in both directions and are suitable for grease lubrication. If necessary, the labyrinth can be relubricated. For this purpose, a lubrication hole must be made in the upper housing section for each labyrinth seal. The optimum positions are indicated by cast-in pilot holes on the top of the housing.

☞ Taconite seals TA

Taconite seals TA comprise two rings, of which one is located in the housing and the other on the shaft. An axial and a radial labyrinth is formed between these rings, where the effectiveness of the latter is increased by means of two spiral rings. Due to the non-contact sealing, taconite seals are suitable for high speeds. The two statically acting O rings are made from NBR and are suitable for temperatures of up to +100 °C.

Taconite seals are designed for extreme operating conditions characterised by heavy contamination and the impact of abrasive particles.

Taconite seals allow shaft misalignment of up to 0,3° in both directions and are suitable for grease lubrication. For relubrication, the seal is fitted with a lubrication nipple.

☞ Split labyrinth seals LERS

☞ Split

For plumber block housings SAF, labyrinth seals are also available in a split design. As a result, the work involved in replacing the seal can be considerably reduced.

☞ Split taconite seals TAS

☞ Split

For plumber block housings SAF, taconite seals are also available in a split design. As a result, the work involved in replacing the seal can be considerably reduced. Split taconite seals are not standard seals and are available by agreement.

☞ Covers EC

Covers EC are used with housings closed on one side. The covers fit in the rectangular section annular slots in the housings. They are suitable for temperatures up to +100 °C.





Labyrinth and taconite seal

- ++ = highly suitable
- + = suitable
- (+) = suitable with restrictions
- = not suitable

Sealing	Labyrinth seal, unsplit	Taconite seal, unsplit	
Designation	LER	TA	
Material	Aluminium, NBR	Steel, NBR	
Pieces per pack	1	1	
Suitability for sealing against			
dust	(+)	++	
fine, solid particles	+	++	
coarse, solid particles	+	++	
slivers	++	++	
spray liquids	-	++	
Operating limits			
Long term temperature	°C	-40 to +100 (due to NBR)	-40 to +100 (due to NBR)
	°F	-40 to +210 (due to NBR)	-40 to +210 (due to NBR)
Circumferential velocity	m/s	No restriction	No restriction
Misalignment	°	≤0,3	≤0,3
Low friction		++	+
Axial shaft displacement (suitability as non-locating bearing)		+	+
Vertical arrangement		(+)	(+)
Suitability for grease relubrication		+	++
Suitability for oil lubrication		(+)	-
Compatibility with sunlight		++	++
Preconditions			
Tolerance class ¹⁾ of shaft diameter		h8 (h9)	h8 (h9)
Shaft roughness	µm	Ra 3,2	Ra 3,2

¹⁾ The envelope requirement © applies

Scope of delivery

When ordering a split plummer block housing SAF of universal design SAF..U, the accessories frequently required for standard shaft diameters (labyrinth seals, covers and locating rings) are already included in the scope of delivery. Depending on the housing configuration, it may be necessary to order other accessories separately.

Further information



Detailed information on split plummer block housings SAF: Split Plummer Block Housings SAF ► TPI 229.

4.3

Split plummer block housings RLE

 *Housings for the bearing arrangements of back-up rollers*

 **4**
Split plummer block housings RLE

Split plummer block housings RLE were developed specifically for the bearing arrangements of back-up rollers ► 1673 |  4.



0009F5 65

 *Shaft diameters from 180 mm to 500 mm*

Suitable bearings

The dimensions of split plummer block housings RLE are matched to spherical roller bearings 241 and toroidal roller bearings C41 ► 1673 |  4. The range of shaft diameters is between 180 mm and 500 mm.

 **4**
Bearing type and sizes

Bearing type	Size
Spherical roller bearings	24122..-K30 to 241/500..-K30
■ with tapered bore and withdrawal sleeve	
■ with cylindrical bore	24122 to 241/500
Toroidal roller bearings	C4120..-K30 to C41/500..-K30
■ with tapered bore and withdrawal sleeve	
■ with cylindrical bore	C4120 to C41/500

 *Flake graphite cast iron as standard*

Materials

Material for housing body:

- flake graphite cast iron (standard)
- spheroidal graphite cast iron
- cast steel.



 *Housings in locating bearing design and non-locating bearing design*

Locating and non-locating bearings

The housings are supplied as a locating bearing design or non-locating bearing design. In the locating bearing, the bearing is clamped between the housing covers. In the non-locating bearing, the bearing can align itself axially, since the covers have shorter centring collars.

 *Grease lubrication*

Lubrication



Suitable lubrication method:
■ grease lubrication.

 *Housing designs with and without cover*

Sealing

Plummer block housings RLE of design A are intended for the bearing arrangements of shaft ends. One side is closed by a cover and the other side is sealed against the shaft. Design B is intended for continuous shafts, in which case the housing is sealed against the shaft on both sides.

 *Labyrinth rings with felt seal*

The seal is a combination of a labyrinth seal and a felt seal  1674 |  5. The labyrinth is separated from the grease cavity in the housing by oil-soaked felt strips, so a more economical grease can be used for labyrinth lubrication.

The labyrinth rings are unsplit. The seal allows shaft misalignment of up to 0,5° in both directions.

 5
Labyrinth ring with felt seal for plummer block housing RLE

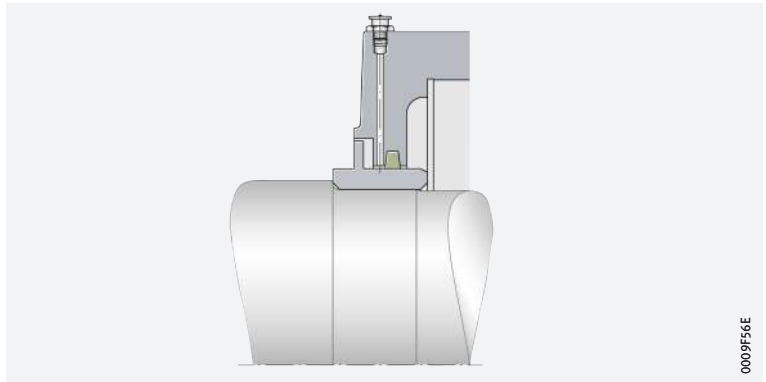



Scope of delivery

In the case of split plummer block housings RLE, the seals and cover (for a housing design closed on one side) are included in the scope of delivery. The rolling bearing and, if necessary, the withdrawal sleeve must be ordered separately.

Further information



Detailed information on split plummer block housings RLE: Bearing Housings   GK 1.

4.4

Split plummer block housings KPG, KPGZ

Housings for converters in the steel industry

Split plummer block housings KPG and KPGZ were developed specifically for the journal bearing arrangement in converters ▶ 1675 | 6.

6
Split plummer block housings KPG, KPGZ



0009F2.55

Shaft diameters from 470 mm to 1320 mm

Suitable bearings

The dimensions of split plummer block housings KPG and KPGZ are matched to spherical roller bearings 249 ▶ 1675 | 5. The housings KPG are intended for bearings with a tapered bore and adjustment sleeve, while the housings KPGZ are intended for bearings with a cylindrical bore. The range of shaft diameters is between 470 mm and 1320 mm.

5
Bearing type and sizes

Bearing type	Size
Spherical roller bearings	249/470..-K30 to 249/1250..-K30
■ with tapered bore and adjustment sleeve	
■ with cylindrical bore	249/500 to 249/1320

Split spherical roller bearings

On the locating bearing side of the converter, an unsplit spherical roller bearing can be replaced by a split spherical roller bearing. Since there is no need to dismantle the drive system, the work involved in mounting can be considerably reduced.



In order to ensure selection of the correct combination of housing and bearing when using split bearings, please contact Schaeffler.



The range of split spherical roller bearings is described in detail in a separate publication ▶ TPI 250.



Spheroidal graphite cast iron

Materials

Material for housing body:

- spheroidal graphite cast iron.

Housings in locating bearing design and non-locating bearing design

Locating and non-locating bearings

The housings are supplied as a locating bearing design or non-locating bearing design. The locating bearing on the drive side provides axial guidance of the converter support ring.

The locating bearing design of the housings KPG and KPGZ is originally designed for the fitting of unsplit spherical roller bearings. The locating bearing arrangement is formed by locating rings on both sides of the bearing. A housing of the locating bearing design can also accommodate a split spherical roller bearing, replacing an unsplit bearing. The non-locating bearing design is fitted with unsplit bearings. The bearing outer ring can be displaced axially in a bearing bush.

Grease lubrication

Lubrication

Suitable lubrication method:
■ grease lubrication.

High-pressure packing as standard

Sealing

Plummer block housings KPG and KPGZ are sealed by means of high-pressure packing. These allow shaft misalignment of up to 1,5°. Profiled rubber seals are available by agreement as special seals
➤ 1676 | 7.

-  **Seals for plummer block housings KPG and KPGZ**
- ① High-pressure packing
 - ② Profiled rubber seal

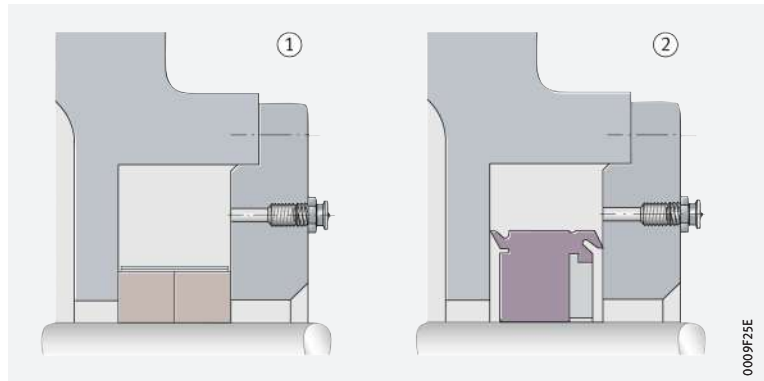

Scope of delivery

In the case of split plummer block housings KPG and KPGZ, the seals are included in the scope of delivery. The rolling bearing and, if necessary, the adjustment sleeve must be ordered separately.

Since customer-specific solutions using these housings are developed for each converter application, we recommend consulting our engineering service before ordering these housings.

Further information



Detailed information on split plummer block housings KPG and KPGZ: Bearing Housings ➤ GK 1, and Rolling Bearing Arrangements for Converters ➤ TPI 148.

4.5 Split plummer block housings LOE

Housings for bearing arrangements running at high speeds

Split plummer block housings LOE are designed for oil lubrication. They are suitable for high speed bearing arrangements, for example in fans ▶ 1677 |  8.

 8
Split plummer block housing LOE



Shaft diameters from 50 mm to 240 mm

Suitable bearings

The dimensions of split plummer block housings LOE are matched to spherical roller bearings 222 and 223 ▶ 1677 |  6. The housings LOE2 and LOE3 are intended for bearings with a cylindrical bore, while the housings LOE5 and LOE6 are intended for bearings with a tapered bore and adapter sleeve. The range of shaft diameters is between 50 mm and 240 mm.

 6
Bearing type and sizes

Bearing type	Size
Spherical roller bearings	
■ with tapered bore and adapter sleeve	22217..-K to 22248..-K
	22314..-K to 22336..-K
■ with cylindrical bore	22214 to 22248
	22310 to 22336

Flake graphite cast iron as standard

Materials

Material for housing body:

- flake graphite cast iron (standard)
- spheroidal graphite cast iron
- cast steel.



☞ *Housings in locating bearing design and non-locating bearing design*

Locating and non-locating bearings

The housings are supplied as a locating bearing design or non-locating bearing design. In the locating bearing, the bearing is clamped between the housing covers. In the non-locating bearing, the bearing can align itself axially, since the covers have shorter centring collars.

☞ *Oil lubrication*

Lubrication

Suitable lubrication method:
■ oil lubrication.

☞ *Housing designs with and without cover*

Sealing

Plummer block housings LOE of design A are intended for the bearing arrangements of shaft ends. One side is closed by a cover and the other side is sealed against the shaft. Design B is intended for continuous shafts, in which case the housing is sealed against the shaft on both sides.

☞ *Labyrinth seals*

The seal used here is a labyrinth seal ► 1678 | ☐ 9. The labyrinth rings are unsplit. The grease chamber in the labyrinth can be relubricated. The labyrinth seal allows shaft misalignment of up to 0,25° in both directions and is suitable for oil lubrication.

☐ 9
Labyrinth seal for plummer block housing LOE

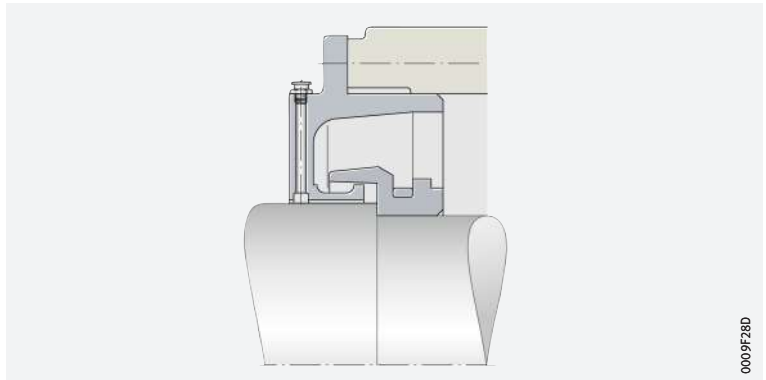

Scope of delivery

In the case of split plummer block housings LOE, the seals and cover (for a housing design closed on one side) are included in the scope of delivery. The rolling bearing and, if necessary, the adapter sleeve or locknut must be ordered separately.

Further information



Detailed information on split plummer block housings LOE: Bearing Housings ► ☐ GK 1.

4.6

Plummer block housing units VRE3

 **Housing units for wide range of applications**

Plummer block housing units VRE3 were originally developed for fan applications, for the flying bearing arrangement of high speed impellers ► 1679  10. The units are now used wherever there is a requirement for a precise bearing arrangement that can be easily mounted, for example in conveying equipment, test rigs, machinery for process engineering, belt transmissions, laboratory machines, textile machinery and feed equipment.

 **10**
Plummer block housing units VRE3



0009F256

 **Completely assembled units**

Complete housing units

Plummer block housing units VRE3 comprise a tubular plummer block housing VR3 with seals and a shaft VRW3 supported in rolling bearings of dimension series 3. The units are completely assembled and the bearings are greased. The units can therefore be integrated directly in existing machinery without substantial preparation.

 **Shaft diameters from 25 mm to 120 mm**

Suitable bearings

Plummer block housing units VRE3 are fitted, depending on their design, with various combinations of deep groove ball bearings, cylindrical roller bearings and angular contact ball bearings ► 1679  7. Only bearings with a cylindrical bore are fitted. The range of shaft diameters is between 25 mm and 120 mm.

 **7**
Plummer block housing units and bearings

Plummer block housing unit	Bearing		
	Quantity	Bearing type	Size
VRE305A – VRE324A	2	Deep groove ball bearings	6305 – 6324
VRE305B – VRE324B	1	Cylindrical roller bearings	NJ305E – NJ324E
	1	Deep groove ball bearings	6305 – 6324
VRE305C – VRE324C	1	Cylindrical roller bearings	NU305E – NU324E
	2	Angular contact ball bearings	7305B.UA – 7324B.UA
VRE305D – VRE324D	1	Cylindrical roller bearings	NU305E – NU324E
	1	Deep groove ball bearings	6305 – 6324
VRE305E – VRE324E	2	Cylindrical roller bearings	NU305E – NU324E
	1	Deep groove ball bearings	6305 – 6324
VRE305F – VRE316F	2	Deep groove ball bearings	6305 – 6316



🔧 *Flake graphite cast iron*

Materials

Material for housing body:

- flake graphite cast iron.

🔧 *Grease lubrication*

Lubrication

Suitable lubrication method:

- grease lubrication.

🔧 *Combined seals comprising felt seal and V ring*

Sealing

Plummer block housing units VRE3 are sealed on both sides by a combined seal comprising a felt seal and V ring ► 1680 | 11. As a result, effective sealing against the ingress of contamination and the escape of lubricant is achieved. The oil-soaked felt strips are inserted in the slots in the covers on the housing. The external V rings are made from NBR and are suitable for temperatures of up to +100 °C. If a circumferential velocity of more than 8 m/s is present, axial support of the V rings is necessary. At or above 12 m/s, the seal lip lifts and the V ring then acts as a splash ring.

11
Felt seal with V ring
for plummer block housing
units VRE3

- ① Sealing of designs A, B and F
- ② Sealing of designs C, D and E

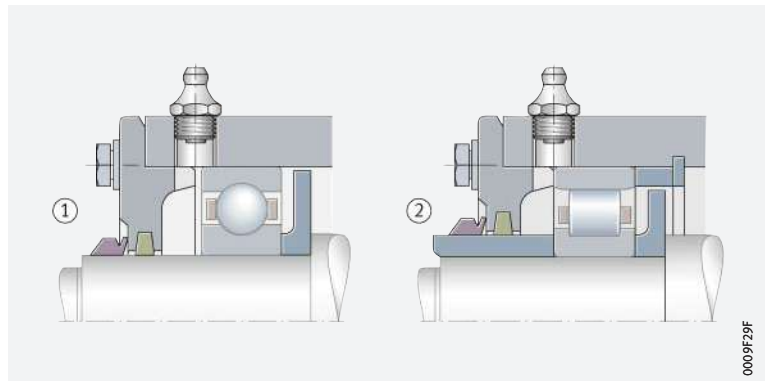

Scope of delivery

Plummer block housing units VRE3 are ideally ordered as complete units. The housing body, shaft, seals and rolling bearings are then included in the scope of delivery. It is also possible, however, to order the housing body (with seals), the shaft and the rolling bearings separately.

Further information



Detailed information on plummer block housings VRE3:
Bearing Housings ► GK 1.

4.7

Unsplit plummer block housings BND

 **Housings for very high loads**

Unsplit plummer block housings BND are suitable for very high loads ▶1681 |  12. The housings, which were originally developed for belt conveyors, can also be beneficially used in materials processing, for example in hard crushers, sugar cane mill drives and rotor shafts in wind turbines.

 **12**
Unsplit plummer block housings BND

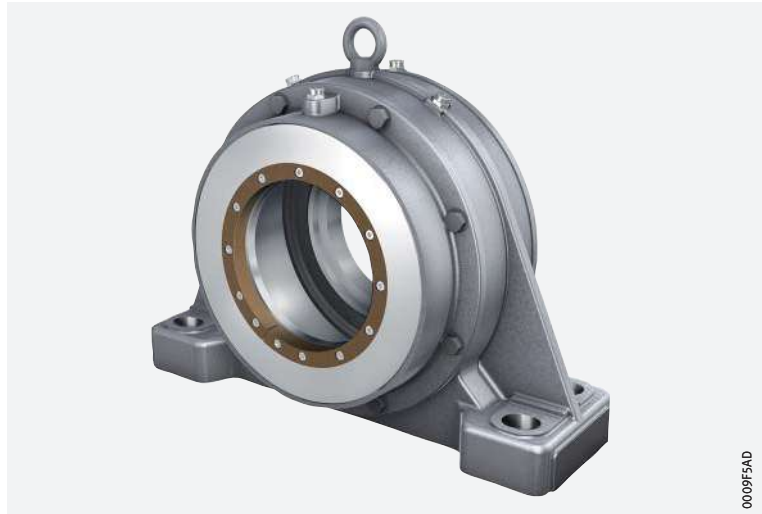

0009F5AD

 **Shaft diameters from 60 mm to 420 mm**

Suitable bearings

The dimensions of unsplit plummer block housings BND are matched to spherical roller bearings 222, 230, 231 and 232 and toroidal roller bearings C22, C30, C31 and C32 ▶1681 |  8. The range of shaft diameters is between 60 mm and 420 mm.

 **8**
Bearing type and sizes

Bearing type	Size
Spherical roller bearings	
■ with tapered bore and adapter sleeve	22213..-K to 22284..-K 23024..-K to 23084..-K 23122..-K to 23184..-K 23222..-K to 23284..-K
■ with cylindrical bore	22213 to 22284 23024 to 23084 23122 to 23184 23222 to 23284
Toroidal roller bearings	
■ with tapered bore and adapter sleeve	C2212..-K to C2284..-K C3022..-K to C3084..-K C3120..-K to C3184..-K C3222..-K to C3284..-K
■ with cylindrical bore	C2212 to C2284 C3022 to C3084 C3120 to C3184 C3222 to C3284



 **Cast steel as standard**

Materials

Material for housing body:

- cast steel (standard)
- spheroidal graphite cast iron.

👉 Housings in locating bearing design and non-locating bearing design

Locating and non-locating bearings

The housings are supplied as a locating bearing design or non-locating bearing design. In the locating bearing, the bearing is clamped between the housing covers. In the non-locating bearing, the bearing can align itself axially, since the covers have shorter centring collars.

👉 Grease lubrication

Lubrication

Suitable lubrication method:
■ grease lubrication.

👉 Housing designs with and without cover

Sealing

Plummer block housings BND of design A are intended for the bearing arrangements of shaft ends. One side is closed by a cover and the other side is sealed against the shaft. Design B is intended for continuous shafts, in which case the housing is sealed against the shaft on both sides.

👉 Labyrinth and taconite seals

Labyrinth seals (suffix Y) or taconite seals (suffix T) can be used
▶ 1683 | 9. Where shafts of constant diameter are used, the seals are located on the shaft by means of slotted conical clamping rings made from laminated fabric. The labyrinth rings, taconite seals and covers are unsplit.

The seals allow shaft misalignment of up to 0,5° in both directions and are suitable for grease lubrication.

Labyrinth and taconite seal

- ++ = highly suitable
 + = suitable
 (+) = suitable with restrictions
 - = not suitable

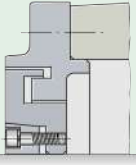
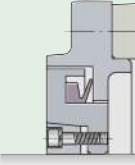
Sealing		Labyrinth seal, unsplit	Taconite seal, unsplit
			
Designation		Suffix Y	Suffix T
Suitability for sealing against			
dust		+	++
fine, solid particles		+	++
coarse, solid particles		+	++
slivers		++	++
spray liquids		-	+
Operating limits			
Long term temperature	°C	-30 to +100	-30 to +100
	°F	-22 to +210	-22 to +210
Circumferential velocity	m/s	No restriction	≤12
Misalignment	°	≤0,5	≤0,5
Low friction		++	+
Axial shaft displacement (suitability as non-locating bearing)		+	+
Vertical arrangement		-	-
Suitability for grease relubrication		+	++
Suitability for oil lubrication		-	-
Compatibility with sunlight		++	++
Preconditions			
Tolerance class ¹⁾ of shaft diameter		h8 (h9)	h8 (h9)
Shaft roughness	μm	Ra 3,2	Ra 3,2



¹⁾ The envelope requirement  applies

Scope of delivery

In the case of unsplit plummer block housings BND, the seals and cover (for a housing design closed on one side) are included in the scope of delivery. The rolling bearing and, if necessary, the adapter sleeve must be ordered separately.

Further information



Detailed information on unsplit plummer block housings BND: Bearing Housings   GK 1.



4.8 Take-up housings SPA

Housings for tensioner drum bearing arrangements

Take-up housings SPA are combined with FAG spherical roller bearings, seals and grease filling to form bearing arrangement units for very high loads > 1684 | 13. The housings are unsplit. They were developed specifically for tensioner drum bearing arrangements in belt conveyor plant. There is a yoke-shaped drawbar eye for attachment to the tensioning device. The housing is guided by means of rails in the belt support structure.

13
 Take-up housing SPA



Shaft diameters from 50 mm to 400 mm

10
 Bearing type and sizes

Suitable bearings

The dimensions of take-up housings SPA are matched to spherical roller bearings 222..-K, 230..-K, 231..-K and 232..-K > 1684 | 10. The range of shaft diameters is between 50 mm and 400 mm.

Bearing type	Size
Spherical roller bearings ■ with tapered bore and adapter sleeve	22211..-K to 22228..-K
	23028..-K to 23056..-K
	23132..-K to 23176..-K
	23222..-K to 23284..-K

Cast steel as standard

Materials

Material for housing body:

- cast steel (standard)
- spheroidal graphite cast iron.

Housings in locating bearing design and non-locating bearing design

Locating and non-locating bearings

The housings are supplied as a locating bearing design or non-locating bearing design. In the locating bearing, the bearing is clamped between the housing covers. In the non-locating bearing, the bearing can align itself axially, since the covers have shorter centring collars.

Grease lubrication

Lubrication

Suitable lubrication method:

- grease lubrication.

Housing designs with and without cover

Sealing

Take-up housings SPA of design A are intended for the bearing arrangements of shaft ends. One side is closed by a cover and the other side is sealed against the shaft. Design B is intended for continuous shafts, in which case the housing is sealed against the shaft on both sides.

Labyrinth and taconite seals

Labyrinth seals (suffix Y) or taconite seals (suffix T) can be used ► 1685 | 11. Where shafts of constant diameter are used, the seals are located on the shaft by means of slotted conical clamping rings made from laminated fabric. The labyrinth rings, taconite seals and covers are unsplit.

The seals allow shaft misalignment of up to 0,5° in both directions and are suitable for grease lubrication.

11

Labyrinth and taconite seal

- ++ = highly suitable
 + = suitable
 (+) = suitable with restrictions
 – = not suitable

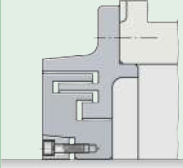
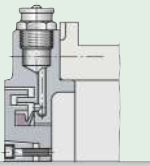
Sealing	Labyrinth seal, unsplit	Taconite seal, unsplit	
			
Designation	Suffix Y	Suffix T	
Suitability for sealing against			
dust	+	++	
fine, solid particles	+	++	
coarse, solid particles	+	++	
slivers	++	++	
spray liquids	–	+	
Operating limits			
Long term temperature	°C	–30 to +100	–30 to +100
	°F	–22 to +210	–22 to +210
Circumferential velocity	m/s	No restriction	≤12
Misalignment	°	≤0,5	≤0,5
Low friction		++	+
Axial shaft displacement (suitability as non-locating bearing)		+	+
Vertical arrangement		–	–
Suitability for grease relubrication		+	++
Suitability for oil lubrication		–	–
Compatibility with sunlight		++	++
Preconditions			
Tolerance class ¹⁾ of shaft diameter		h8 (h9)	h8 (h9)
Shaft roughness	μm	Ra 3,2	Ra 3,2

¹⁾ The envelope requirement © applies



Scope of delivery

In the case of take-up housings SPA, the seals and cover (for a housing design closed on one side) are included in the scope of delivery. The rolling bearing and, if necessary, the adapter sleeve must be ordered separately.

Further information



Detailed information on take-up housings SPA: Bearing Housings ► GK 1.

4.9 Flanged housings F112

Housings for wide range of applications

Flanged housings F112 can be used in a wide variety of applications, for example in machine structures and support structures ▶ 1686 | 14.

14
 Flanged housing F112



Shaft diameters from 20 mm to 60 mm

Suitable bearings

The dimensions of flanged housings F112 are matched to self-aligning ball bearings 112 with an extended inner ring ▶ 1686 | 12. The range of shaft diameters is between 20 mm and 60 mm.

12
 Bearing type and sizes

Bearing type	Size
Self-aligning ball bearings	11204 to 11212
■ with cylindrical bore and extended inner ring	

Flake graphite cast iron

Materials

Material for housing body:
 ■ flake graphite cast iron.

Housing in locating bearing design only

Locating bearing

In flanged housings F112, the self-aligning ball bearing is clamped between the abutment shoulder in the housing and the cover. As a result, the bearing acts as a locating bearing.

Grease lubrication

Lubrication

Suitable lubrication method:
 ■ grease lubrication.

Felt seals

Sealing

Flanged housings F112 are sealed by means of felt seals ▶ 1687 | 15. The felt seals allow shaft misalignment of up to 0,5° in both directions and are suitable for grease lubrication. The oil-soaked felt strips must be inserted in the associated slots in the housing.

 **15**

Felt seal for flanged housing F112

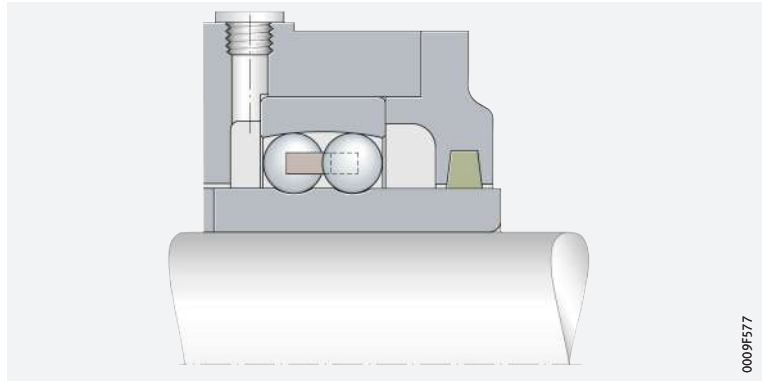

Scope of delivery

In the case of flanged housings F112, the felt strips for sealing the housing are included in the scope of delivery. The rolling bearing must be ordered separately.

Further information



Detailed information on flanged housings F112: Bearing Housings ►  GK 1.

4.10

Flanged housings F5

 *Housings for wide range of applications*

Flanged housings F5 can be used in a wide variety of applications ► 1687  16.

 **16**

Flanged housing F5



☞ *Shaft diameters from 20 mm to 100 mm*

☞ **13**
Bearing types and sizes

Suitable bearings

Flanged housings F5 are intended for fitting with self-aligning ball bearings, barrel roller bearings and spherical roller bearings with a tapered bore that are located on the shaft using adapter sleeves ▶ 1688 | ☞ 13. The range of shaft diameters is between 20 mm and 100 mm.

Bearing type	Size
Spherical roller bearings ■ with tapered bore and adapter sleeve	22205..-K to 22222..-K
Self-aligning ball bearings ■ with tapered bore and adapter sleeve	1205-K to 1222-K 2205-K to 2222-K
Barrel roller bearings ■ with tapered bore and adapter sleeve	20205-K to 20222-K

☞ *Flake graphite cast iron as standard*

Materials

Material for housing body:

- flake graphite cast iron (standard)
- spheroidal graphite cast iron.

☞ *Locating bearing arrangement by means of locating rings*

Locating and non-locating bearings

The bearing seats in the housing are machined such that the bearings are movable and can thus function as non-locating bearings. Locating bearing arrangements can be achieved by the insertion of locating rings. For housings F505 to F513, locating rings FE are used, while for housings F515 to F522, locating rings FRM are used. The quantity of locating rings required is 1 or 2. Two rings are inserted on both sides of the bearing, while a single ring is inserted on the side with the adapter sleeve nut.

☞ *Grease lubrication*

Lubrication

Suitable lubrication method:

- grease lubrication.

☞ *Housing designs with and without cover*

Sealing

Flanged housings F5 of design A are intended for the bearing arrangements of shaft ends. One side is closed by a cover and the other side is sealed against the shaft. Design B is intended for continuous shafts, in which case the housing is sealed against the shaft on both sides.

☞ *Felt seals*

Flanged housings F5 are sealed by means of felt seals ▶ 1688 | ☞ 17. The felt seals allow shaft misalignment of up to 0,5° in both directions and are suitable for grease lubrication. The oil-soaked felt strips must be inserted in the associated slots in the housing.

☞ **17**
Felt seal for flanged housing F5

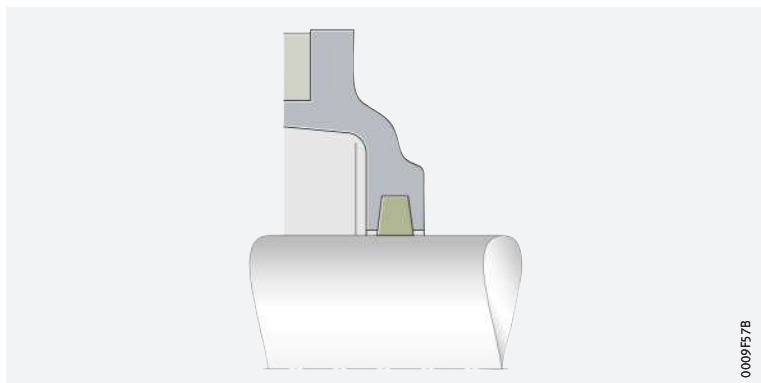

Scope of delivery

In the case of flanged housings F5, the felt strips for sealing the housing as well as the cover (for a housing design closed on one side) are included in the scope of delivery. Locating rings must be ordered separately. The rolling bearing and the adapter sleeve must also be ordered separately.

Further information



Detailed information on flanged housings F5: Bearing Housings ►  GK 1.

4.11 Legal notice regarding data freshness

The further development of products may also result in technical changes to catalogue products

Of central interest to Schaeffler is the further development and optimisation of its products and the satisfaction of its customers. In order that you, as the customer, can keep yourself optimally informed about the progress that is being made here and with regard to the current technical status of the products, we publish any product changes which differ from the printed version in our electronic product catalogue.



We therefore reserve the right to make changes to the data and illustrations in this catalogue. This catalogue reflects the status at the time of printing. More recent publications released by us (as printed or digital media) will automatically precede this catalogue if they involve the same subject. Therefore, please always use our electronic product catalogue to check whether more up-to-date information or modification notices exist for your desired product.

Link to electronic product catalogue



The following link will take you to the Schaeffler electronic product catalogue: ► <https://medias.schaeffler.com>.

4.12 Further information



In addition to the data in this chapter, the following chapters must also be observed in the selection of a housing:

- Lubrication ► 70|6
- Locating and non-locating bearing concepts ► 1571|1.2
- Housing materials ► 1573|1.3

Further information:



- Comprehensive housing catalogue GK 1 ► <https://www.schaeffler.de/std/1D54>
- Electronic housing selection wizard ► <https://www.schaeffler.de/std/1D61>

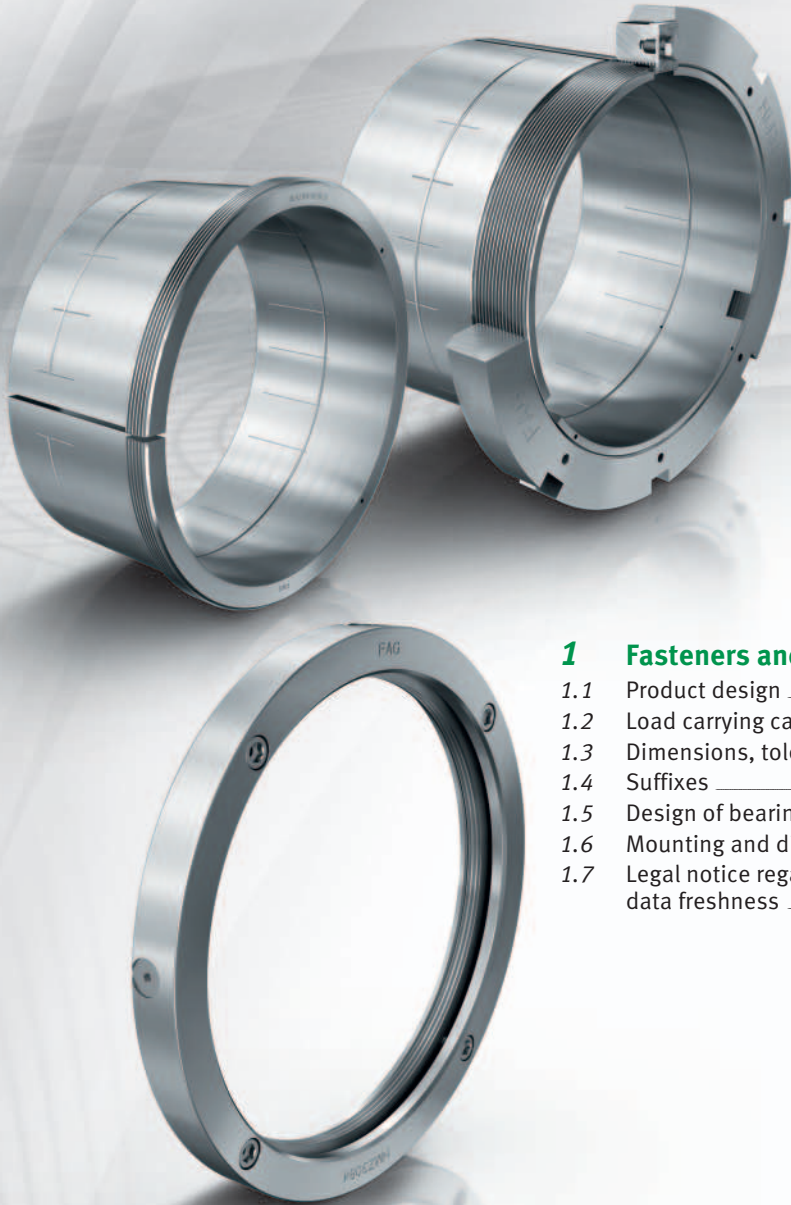

Fasteners and retainers



1	Fasteners and retainers	1692
1.1	Product design	1692
1.2	Load carrying capacity	1697
1.3	Dimensions, tolerances	1697
1.4	Suffixes	1698
1.5	Design of bearing arrangements	1698
1.6	Mounting and dismounting	1699
1.7	Legal notice regarding data freshness	1699

Product tables	1700
 Adapter sleeves	1700
 Withdrawal sleeves	1714
Locknuts	1738
Shaft nuts	1742
Tab washers	1744
Retaining brackets	1746



1 Fasteners and retainers



Adapter sleeves and withdrawal sleeves are suitable for locating bearings with a tapered bore on cylindrical shafts ▶ 1692 |  1, whereby:

- adapter sleeves require no additional means of retention on the shaft ▶ 1692
- withdrawal sleeves give easier subsequent dismounting of the bearing ▶ 1694
- designs with oil slots permit the use of the hydraulic method ▶ 1693 and ▶ 1694.

Locknuts and shaft nuts are suitable for locating bearings on cylindrical and tapered shafts, or on adapter sleeves, and for mounting and dismounting of bearings on withdrawal sleeves, whereby:

- locknuts can be tightened particularly easily with striking-face or hook wrenches ▶ 1695
- shaft nuts do not require any slots on the outside of the shaft, which increases the strength of the shaft and makes it easier to produce ▶ 1695.

Tab washers and retaining brackets are suitable for securing locknuts, whereby:

- tab washers for smaller locknuts (series KM and KML) ▶ 1696 and
- retaining brackets for larger locknuts (series HM30 and HM31) are used ▶ 1696.



Location of a spherical roller bearing with tapered bore

- ① Cylindrical shaft, adapter sleeve with locknut and tab washer
- ② Cylindrical shaft, withdrawal sleeve with locknut and tab washer

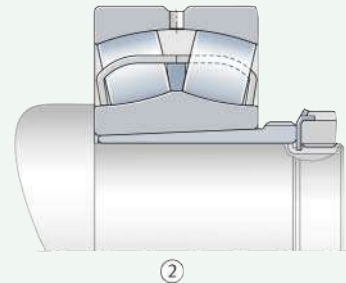
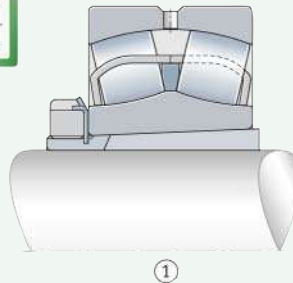

1.1 Product design

Adapter sleeves



Suitability and function

Adapter sleeves are suitable where bearings with a tapered bore are to be located on cylindrical shafts. In this case, the bearing is pressed onto the adapter sleeve until the required reduction in radial internal clearance is achieved. Adapter sleeves require no additional means of retention on the shaft. The bearings can be positioned at any point on shafts with a constant diameter.

If adapter sleeves are used with a support ring to DIN 5418 on stepped shafts, the bearings can be axially located to high accuracy. In addition, this gives simpler dismounting of the bearings.

Design features

The tensile strength of the adapter sleeve material is at least 430 N/mm². Adapter sleeves are slotted and have a shaft thread for the locknut. Depending on the series, the outside surface of the adapter sleeves has a taper of 1:12 or 1:30 **▶ 1693** |  1.

 **1**
Adapter sleeves

Series	Taper on the outside surface
H2, H3, H23, H28, H30, H31, H32, H33, H38, H39	1:12
H240, H241, H242, H248, H249	1:30

Adapter sleeves for the hydraulic method

The mounting and dismounting of large bearings requires high mounting forces and is made easier by using the hydraulic method. Adapter sleeves for the hydraulic method have oil slots and an oil connector **▶ 1693** |  2. Depending on the arrangement of oil slots and oil connector, the adapter sleeves have the suffix HG, HGJ, HK or HKJ **▶ 1698** | 1.4. The product tables give the mounting dimensions for the oil connector.

Adapter sleeves with a sleeve bore diameter greater than or equal to 300 mm are only available in the design for the hydraulic method. For adapter sleeves with sleeve bore measurements between 140 mm and 280 mm, a design with or without oil slots can be selected in the product tables. Smaller adapter sleeves for the hydraulic method are available by agreement.

 **2**
Spherical roller bearings on adapter sleeve for hydraulic method

- ① Oil connector on threaded side
- ② Oil connector on taper side

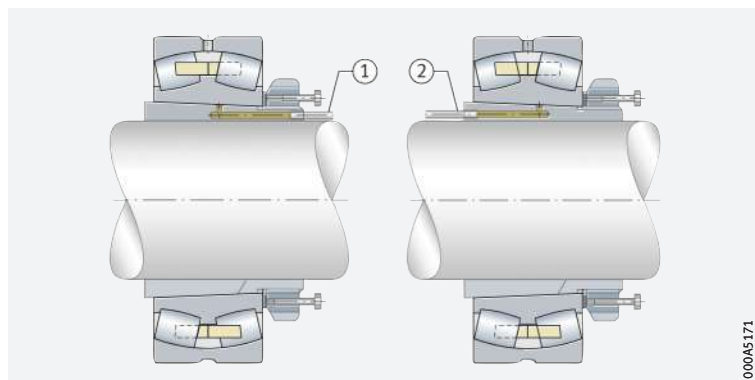

000A5171

Available designs

Adapter sleeves are supplied complete with locknuts and tab washers. For larger sizes, retaining brackets are used instead of tab washers **▶ 1693** |  3. Sizes not listed in the product tables are available by agreement.

The product tables contain adapter sleeves for metric shafts. Adapter sleeves for inch size shafts are available by agreement. Adapter sleeves for sealed spherical roller bearings and for toroidal roller bearings are also available by agreement.

 **3**
Adapter sleeves

- ① With locknut and tab washer
- ② With locknut and retaining bracket

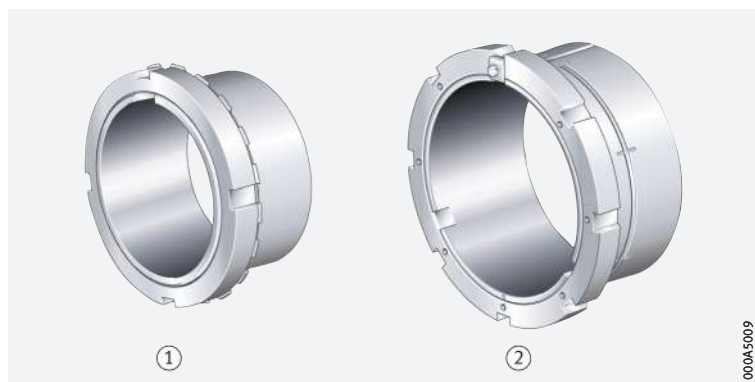

000A5009



Withdrawal sleeves

Suitability and function

Withdrawal sleeves are suitable where bearings with a tapered bore are located on cylindrical shafts. The tapered sleeve is pressed into the bearing bore until the required reduction in radial internal clearance is achieved. The bearing must be axially supported during this process, for example by means of a shaft shoulder.

Withdrawal sleeves give easier dismounting of the bearings, as the press fit of the bearing can be loosened with the aid of a locknut applied to the withdrawal sleeve.



Design features

The tensile strength of the withdrawal sleeve material is at least 430 N/mm². Withdrawal sleeves are slotted and have a shaft thread for the locknut. Depending on the series, the outside surface of the withdrawal sleeves has a taper of 1:12 or of 1:30  2.

Withdrawal sleeves

Series	Taper on the outside surface
AH2, AH(X)3, AH22, AH(X)23, AH28, AH(X)30, AH(X)31, AH(X)32, AH33, AH38, AH39	1:12
AH240, AH241, AH242, AH248, AH249	1:30

Withdrawal sleeves for the hydraulic method

The mounting and dismounting of large bearings requires high mounting forces and is made easier by using the hydraulic method. Withdrawal sleeves for the hydraulic method have oil slots in the tapered outside surface and in the sleeve bore  4. Oil connectors are offset to each other by 90°. The hydraulic withdrawal sleeves have the suffix H  1.4. The product tables give the mounting dimensions for the oil connector.

Withdrawal sleeves with a sleeve bore diameter greater than or equal to 300 mm are only available in the design for the hydraulic method. For withdrawal sleeves with sleeve bore measurements between 150 mm and 280 mm, a design with or without oil slots can be selected in the product tables. Smaller withdrawal sleeves for the hydraulic method are available by agreement.

Spherical roller bearing on withdrawal sleeve for hydraulic method

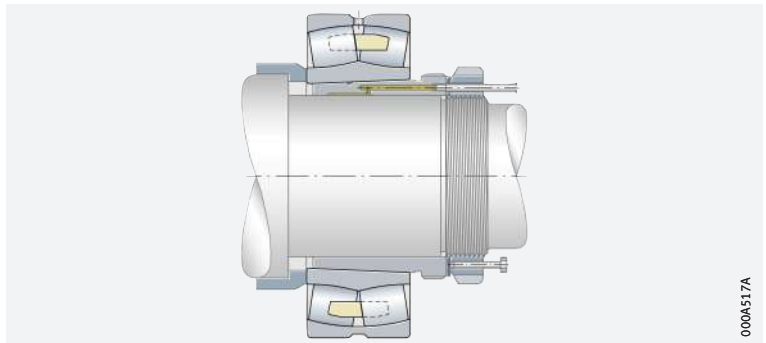

Available designs

Locknuts and retainers are not included in the scope of delivery for withdrawal sleeves  5. Sizes not listed in the product tables are available by agreement.

The product tables contain withdrawal sleeves for metric shafts. Withdrawal sleeves for inch size shafts are available by agreement.

5 Withdrawal sleeve



000A4FF4

Suitability and function

Locknuts can be used to locate bearings on shafts or adapter sleeves. They also give easier mounting of bearings with a tapered shaft seat and the mounting and dismounting of bearings on withdrawal sleeves.

Design features

The locknuts are made from steel and the tensile strength of the material is at least 350 N/mm².

They have four or eight evenly spaced slots on the circumference, into which hook wrenches or striking-face wrenches can be fitted ► 1695 | 6.

Available designs

Locknuts with threaded holes for mounting screws are available by agreement. These locknuts have the suffix H.

Precision locknuts are described in a separate publication ► TPI 123.

6 Locknuts

- ① KM, KML, HM..T
- ② HM30, HM31



000A4FFD

Suitability and function

Shaft nuts HMZ allow precise, secure axial location of bearings on cylindrical and tapered shafts or on adapter sleeves.

Design features

The shaft nuts are made from steel and the tensile strength is at least 350 N/mm².

Shaft nuts HMZ are interchangeable with conventional locknuts HM and KM. They are secured, however, not by means of form fit using tab washers or retaining brackets, but by force locking. Four or eight axial clamping screws allow uniform clamping of the thread flanks on the circumference ► 1696 | 7. There is no need for slots on the outside diameter of the nut. For screw mounting on the shaft thread, four or eight threaded blind holes are applied to the circumference of the nut, into which the threaded rod also supplied is screwed.

Advantages for the shaft

A shaft with a screw mounted shaft nut does not require a retaining slot. As a result, the shaft has higher strength and is more economical to manufacture than a shaft with a retaining slot for a tab washer or retaining bracket.



7
Shaft nut

The clamping screws serve to generate a force locking connection between the nut and shaft thread

Detailed description of shaft nuts HMZ ►  TPI WL 91-8.



0004680C

Retainers

Tab washers

 For smaller locknuts

Tab washers MB and MBL are simple, reliable elements for securing smaller locknuts (series KM and KML) ► 1696 |  8.

They have an inner tab and several outer tabs evenly spaced around the circumference. The inner tab grips in the slot on the adapter sleeve or shaft, one of the outer tabs is bent into a slot in the nut for location.

The washers are made from steel and the tensile strength of the material is at least 300 N/mm².

Retaining brackets

 For locknuts HM30 and HM31

Retaining brackets MS are used to secure locknuts HM30 and HM31.

The retaining brackets are fixed to the locknut using a hexagonal screw. They engage in a slot in the nut and in the adapter sleeve or shaft ► 1696 |  8.

The fixing screws are secured with a retainer.

8
Retainers

- ① Tab washer
- ② Retaining bracket with screw

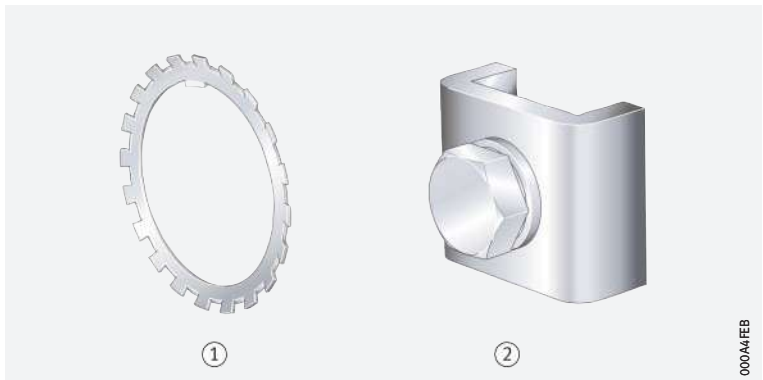

00046FEB

1.2 Load carrying capacity

Static axial load carrying capacity of locknuts and shaft nuts



The static axial load carrying capacity of locknuts and shaft nuts must not be exceeded, as this may damage the thread. In this case, operational reliability can no longer be ensured.

The values for static axial load carrying capacity have been calculated in accordance with guideline VDI 2230. The calculation assumes that the quality requirements relating to the shaft thread are met ▶ 1698|1.5.

The values for the static axial load carrying capacity of locknuts are contained in the product tables ▶ 1738|.



For information on the static axial load carrying capacity of shaft nuts HMZ, please consult Schaeffler.

1.3 Dimensions, tolerances

Adapter and withdrawal sleeves



Dimensions and material correspond to DIN 5415 for adapter sleeves, DIN 5416 for withdrawal sleeves and to ISO 2982-1.

The bore tolerance of adapter and withdrawal sleeves before splitting for a taper 1:12 is in tolerance class JS9, for a taper 1:30 in tolerance class JS7 to DIN EN ISO 286-1.

Up to a thread diameter of 200 mm, adapter and withdrawal sleeves have a metric fine pitch thread to DIN 13, tolerance class 6g to DIN ISO 965-3. Larger threads are produced as trapezoidal threads to DIN 103, tolerance zone 7e to DIN 103-3.

Withdrawal sleeves are available in designs with modified thread G. These have the suffix G.

Locknuts and shaft nuts



Dimensions and material correspond to DIN 981 and ISO 2982-2.

Up to a thread diameter of 200 mm, locknuts and shaft nuts have a metric fine pitch thread to DIN 13, tolerance class 6H to DIN ISO 965-3. Larger threads are produced as trapezoidal threads to DIN 103, tolerance zone 7H to DIN 103-3.



1.4 Suffixes

For a description of the suffixes used in this chapter ▶ 1698 | 3 to
▶ 1698 | 5 and **medias** interchange
▶ <https://www.schaeffler.de/std/1D52>.

 3
Suffixes and
corresponding descriptions,
adapter sleeves

Suffix	Description of suffix	
HG	Hydraulic adapter sleeve with oil slots on the taper face	Standard
HGJ	Hydraulic adapter sleeve with oil slots on the taper face and in the bore	
HK	Design as for HG, but with oil connectors on the opposing axial face	
HKJ	Design as for HGJ, but with oil connectors on the opposing axial face	

 4
Suffixes and
corresponding descriptions,
withdrawal sleeves

Suffix	Description of suffix	
H	Hydraulic withdrawal sleeve with oil slots on the taper face and in the bore	Standard
G	Hydraulic withdrawal sleeve with modified thread G	

 5
Suffixes and
corresponding descriptions,
locknuts

Suffix	Description of suffix	
H	Locknuts with threaded holes for mounting screws	Standard
HP	Locknuts with threaded holes for mounting screws and through hole for oil connector to withdrawal sleeves ▶ 1694 4	

1.5 Design of bearing arrangements

Shafts for adapter sleeves and withdrawal sleeves

 *Diameter tolerances*

Adapter and withdrawal sleeves adapt themselves to the shaft. Larger diameter tolerances are therefore permissible for shafts where the bearing is located using adapter sleeves or withdrawal sleeves, than in the case of a direct cylindrical seat for a bearing on the shaft. For general applications, shafts toleranced in accordance with tolerance class h9 © to DIN EN ISO 286-1 are sufficient.



 *Geometrical tolerances*

The geometrical tolerances of the shafts must be tighter than the diameter tolerances since the geometrical accuracy affects the running accuracy of the bearing arrangement.



The cylindricity of the shaft for shaft diameters in tolerance classes h7 or h8 should lie within tolerance zone IT5/2 to DIN EN ISO 286-1 and, for shaft diameters in tolerance class h9, within IT6/2.

 *Thread tolerances*

Shaft thread for locknuts and shaft nuts

Tolerance specifications must be observed for the thread on shafts that locknuts or shaft nuts are screw mounted onto. Metric shaft threads to DIN 13 must be manufactured in accordance with tolerance class 6g to ISO 965-3. Trapezoidal threads to DIN 103 must be manufactured in accordance with tolerance class 7e to DIN 103-3.



1.6 Mounting and dismounting





Adapter and withdrawal sleeves



The mounting and dismounting options for adapter and withdrawal sleeves, by hydraulic or mechanical methods, must be taken into consideration in the design of the bearing position.

Suitable mounting method dependent on the bearing size

The larger the bearing, the higher the forces that will be required for mounting. The bearing is either pressed onto the adapter or withdrawal sleeve, or the sleeve is pressed between the bearing bore and the shaft. Various mounting methods are suitable depending on the size of the bearing:

- direct application of axial mounting forces by tightening of the locknut or shaft nut ► 1692 |  1
- nuts with pressure screws ► 197 |  7
- hydraulic nuts ► 197 |  8
- hydraulic method, made possible through the use of hydraulic adapter or withdrawal sleeves with oil slots and oil connectors ► 1693 |  2 and ► 1694 |  4.



Further information on the mounting and dismounting of adapter and withdrawal sleeves is given in the introductory chapter on the mounting and dismounting of bearings ► 191 | 10, the chapter on spherical roller bearings ► 685 | 1.16 and ► 691 | 1.17, and in the Schaeffler Mounting Handbook ►  MH 1.

Schaeffler Mounting Handbook

Rolling bearings must be handled with great care

Rolling bearings are well-proven precision machine elements for the design of economical and reliable bearing arrangements, which offer high operational security. In order that these products can function correctly and achieve the envisaged operating life without detrimental effect, they must be handled with care.



The Schaeffler Mounting Handbook MH 1 gives comprehensive information about the correct storage, mounting, dismounting and maintenance of rotary rolling bearings ► <https://www.schaeffler.de/std/1D53>. It also provides information which should be observed by the designer, in relation to the mounting, dismounting and maintenance of bearings, in the original design of the bearing position. This book is available from Schaeffler on request.

1.7 Legal notice regarding data freshness

The further development of products may also result in technical changes to catalogue products

Of central interest to Schaeffler is the further development and optimisation of its products and the satisfaction of its customers. In order that you, as the customer, can keep yourself optimally informed about the progress that is being made here and with regard to the current technical status of the products, we publish any product changes which differ from the printed version in our electronic product catalogue.



We therefore reserve the right to make changes to the data and illustrations in this catalogue. This catalogue reflects the status at the time of printing. More recent publications released by us (as printed or digital media) will automatically precede this catalogue if they involve the same subject. Therefore, please always use our electronic product catalogue to check whether more up-to-date information or modification notices exist for your desired product.

Link to electronic product catalogue



The following link will take you to the Schaeffler electronic product catalogue: ► <https://medias.schaeffler.com>.





Adapter sleeves

With locknut and retainer

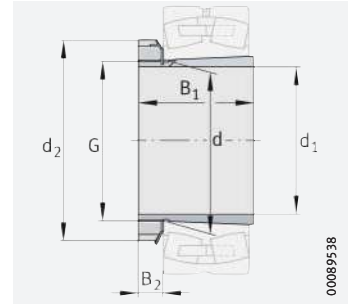

Taper 1:12
(taper 1:30 for H240, H241)
Tab washer MB

00089538

d₁ = 14 – 90 mm

Main dimensions			Mass m ≈ kg	Designation ▶ 1698 1.4			Dimensions		
d ₁	G	B ₁		Adapter sleeve Complete	Locknut	Retainer	d	d ₂	B ₂ ≈
14	M17×1	21	0,03	H203	KM3	MB3	17	28	6
17	M20×1	24	0,04	H204	KM4	MB4	20	32	7
	M20×1	28	0,04	H304	KM4	MB4	20	32	7
	M20×1	31	0,05	H2304	KM4	MB4	20	32	7
20	M25×1,5	26	0,07	H205	KM5	MB5	25	38	8,25
	M25×1,5	29	0,07	H305	KM5	MB5	25	38	8,25
	M25×1,5	35	0,09	H2305	KM5	MB5	25	38	8,25
25	M30×1,5	27	0,1	H206	KM6	MB6	30	45	8,25
	M30×1,5	31	0,11	H306	KM6	MB6	30	45	8,25
	M30×1,5	38	0,13	H2306	KM6	MB6	30	45	8,25
30	M35×1,5	29	0,136	H207	KM7	MB7	35	52	9,25
	M35×1,5	35	0,153	H307	KM7	MB7	35	52	9,25
	M35×1,5	43	0,16	H2307	KM7	MB7	35	52	9,25
35	M40×1,5	31	0,177	H208	KM8	MB8	40	58	10,25
	M40×1,5	36	0,192	H308	KM8	MB8	40	58	10,25
	M40×1,5	46	0,23	H2308	KM8	MB8	40	58	10,25
	M40×1,5	50	0,24	H3308	KM8	MB8	40	58	10,25
40	M45×1,5	33	0,23	H209	KM9	MB9	45	65	11,25
	M45×1,5	39	0,253	H309	KM9	MB9	45	65	11,25
	M45×1,5	50	0,298	H2309	KM9	MB9	45	65	11,25
	M45×1,5	54	0,31	H3309	KM9	MB9	45	65	11,25
45	M50×1,5	35	0,276	H210	KM10	MB10	50	70	12,25
	M50×1,5	42	0,306	H310	KM10	MB10	50	70	12,25
	M50×1,5	55	0,36	H2310	KM10	MB10	50	70	12,25
	M50×1,5	60	0,39	H3310	KM10	MB10	50	70	12,25
50	M55×2	37	0,319	H211	KM11	MB11	55	75	12,5
	M55×2	45	0,358	H311	KM11	MB11	55	75	12,5
	M55×2	59	0,435	H2311	KM11	MB11	55	75	12,5
	M55×2	65	0,46	H3311	KM11	MB11	55	75	12,5
55	M60×2	38	0,35	H212	KM12	MB12	60	80	12,5
	M60×2	47	0,401	H312	KM12	MB12	60	80	12,5
	M60×2	62	0,493	H2312	KM12	MB12	60	80	12,5
	M60×2	70	0,54	H3312	KM12	MB12	60	80	12,5

medias ▶ <https://www.schaeffler.de/std/1E99>



Main dimensions			Mass m ≈ kg	Designation ▶ 1698 1.4			Dimensions		
d_1	G	B_1		Adapter sleeve Complete	Locknut	Retainer	d	d_2	B_2 ≈
60	M65×2	40	0,4	H213	KM13	MB13	65	85	13,5
	M65×2	50	0,471	H313	KM13	MB13	65	85	13,5
	M65×2	65	0,57	H2313	KM13	MB13	65	85	13,5
	M65×2	75	0,63	H3313	KM13	MB13	65	85	13,5
	M70×2	41	0,63	H214	KM14	MB14	70	92	13,5
	M70×2	52	0,74	H314	KM14	MB14	70	92	13,5
	M70×2	68	0,92	H2314	KM14	MB14	70	92	13,5
	M70×2	81	1,08	H3314	KM14	MB14	70	92	13,5
65	M75×2	43	0,71	H215	KM15	MB15	75	98	14,5
	M75×2	55	0,86	H315	KM15	MB15	75	98	14,5
	M75×2	73	1,06	H2315	KM15	MB15	75	98	14,5
	M75×2	87	1,25	H3315	KM15	MB15	75	98	14,5
70	M80×2	46	0,89	H216	KM16	MB16	80	105	16,75
	M80×2	59	1,06	H316	KM16	MB16	80	105	16,75
	M80×2	78	1,31	H2316	KM16	MB16	80	105	16,75
	M80×2	89	1,46	H3316	KM16	MB16	80	105	16,75
75	M85×2	50	1,03	H217	KM17	MB17	85	110	17,75
	M85×2	63	1,21	H317	KM17	MB17	85	110	17,75
	M85×2	82	1,47	H2317	KM17	MB17	85	110	17,75
	M85×2	95	1,68	H3317	KM17	MB17	85	110	17,75
80	M90×2	52	1,21	H218	KM18	MB18	90	120	17,75
	M90×2	65	1,41	H318	KM18	MB18	90	120	17,75
	M90×2	86	1,71	H2318	KM18	MB18	90	120	17,75
	M90×2	95	1,87	H3318	KM18	MB18	90	120	17,75
85	M95×2	55	1,39	H219	KM19	MB19	95	125	18,75
	M95×2	68	1,58	H319	KM19	MB19	95	125	18,75
	M95×2	90	1,95	H2319	KM19	MB19	95	125	18,75
	M95×2	101	2,16	H3319	KM19	MB19	95	125	18,75
90	M100×2	58	1,52	H220	KM20	MB20	100	130	19,75
	M100×2	71	1,76	H320	KM20	MB20	100	130	19,75
	M100×2	76	1,81	H3120	KM20	MB20	100	130	19,75
	M100×2	80	1,77	H24020	KM20	MB20	100	130	19,75
	M100×2	94	1,97	H24120	KM20	MB20	100	130	19,75
	M100×2	97	2,2	H2320	KM20	MB20	100	130	19,75
	M100×2	106	2,38	H3320	KM20	MB20	100	130	19,75

medias ▶ <https://www.schaeffler.de/std/1E9A>





Adapter sleeves

With locknut and retainer

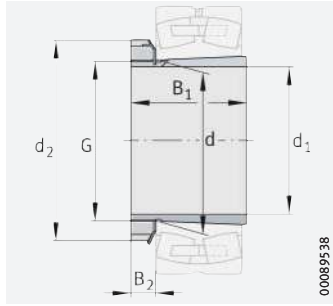

Taper 1:12
(taper 1:30 for H240, H241)
Tab washer MB, MBL

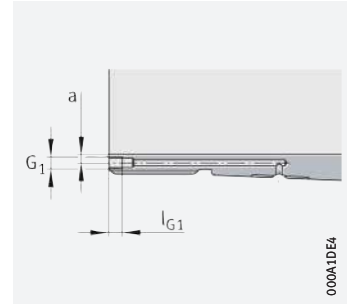

Hydraulic adapter sleeve
(suffix HG)
Mounting dimensions

d₁ = 95 – 150 mm

Main dimensions			Mass m ≈ kg	Designation ▶ 1698 1.4			Dimensions		
d ₁	G	B ₁		Adapter sleeve Complete	Locknut	Retainer	d	d ₂	B ₂
95	M105×2	60	1,74	H221	KM21	MB21	105	140	19,75
	M105×2	74	1,97	H321	KM21	MB21	105	140	19,75
	M105×2	80	2,09	H3121	KM21	MB21	105	140	19,75
	M105×2	101	2,5	H2321	KM21	MB21	105	140	19,75
	M105×2	111	2,71	H3321	KM21	MB21	105	140	19,75
100	M110×2	63	1,95	H222	KM22	MB22	110	145	20,75
	M110×2	77	2,25	H322	KM22	MB22	110	145	20,75
	M110×2	81	2,32	H3122	KM22	MB22	110	145	20,75
	M110×2	90	2,3	H24022	KM22	MB22	110	145	20,75
	M110×2	99	2,45	H24122	KM22	MB22	110	145	20,75
	M110×2	105	2,78	H2322	KM22	MB22	110	145	20,75
	M110×2	117	3,06	H3322	KM22	MB22	110	145	20,75
110	M120×2	60	1,78	H3924	KML24	MBL24	120	145	22
	M120×2	72	2,01	H3024	KML24	MBL24	120	145	22
	M120×2	91	2,24	H24024	KML24	MBL24	120	145	22
	M120×2	88	2,7	H3124	KM24	MB24	120	155	22
	M120×2	111	2,92	H24124	KM24	MB24	120	155	22
	M120×2	112	3,24	H2324	KM24	MB24	120	155	22
	M120×2	132	3,77	H3324	KM24	MB24	120	155	22
115	M130×2	65	2,53	H3926	KML26	MBL26	130	155	23
	M130×2	80	2,96	H3026	KML26	MBL26	130	155	23
	M130×2	102	3,4	H24026	KML26	MBL26	130	155	23
	M130×2	92	3,74	H3126	KM26	MB26	130	165	23
	M130×2	113	4,08	H24126	KM26	MB26	130	165	23
	M130×2	121	4,69	H2326	KM26	MB26	130	165	23
	M130×2	139	5,35	H3326	KM26	MB26	130	165	23
125	M140×2	66	2,78	H3928	KML28	MBL28	140	165	24
	M140×2	82	3,3	H3028	KML28	MBL28	140	165	24
	M140×2	103	3,75	H24028	KML28	MBL28	140	165	24
	M140×2	97	4,46	H3128	KM28	MB28	140	180	24
	M140×2	119	4,81	H24128	KM28	MB28	140	180	24
	M140×2	131	5,66	H2328	KM28	MB28	140	180	24
	M140×2	147	6,32	H3328	KM28	MB28	140	180	24

medias ▶ <https://www.schaeffler.de/std/1E9B>



Main dimensions			Mass m ≈ kg	Designation ▶ 1698 1.4			Dimensions			Mounting dimensions		
d_1	G	B_1		Adapter sleeve Complete	Locknut	Retainer	d	d_2	B_2	G_1	a	l_{G1}
135	M150×2	76	3,64	H3930	KML30	MBL30	150	180	26	–	–	–
	M150×2	87	4,02	H3030	KML30	MBL30	150	180	26	–	–	–
	M150×2	112	4,61	H24030	KML30	MBL30	150	180	26	–	–	–
	M150×2	111	5,7	H3130	KM30	MB30	150	195	26	–	–	–
	M150×2	137	6,1	H24130	KM30	MB30	150	195	26	–	–	–
	M150×2	139	6,76	H2330	KM30	MB30	150	195	26	–	–	–
	M150×2	159	7,66	H3330	KM30	MB30	150	195	26	–	–	–
140	M160×3	78	4,75	H3932	KML32	MBL32	160	190	27,5	–	–	–
	M160×3	78	4,75	H3932-HG	KML32	MBL32	160	190	27,5	M6	4,2	7
	M160×3	93	5,44	H3032	KML32	MBL32	160	190	27,5	–	–	–
	M160×3	93	5,44	H3032-HG	KML32	MBL32	160	190	27,5	M6	4,2	7
	M160×3	118	6,27	H24032	KML32	MBL32	160	190	27,5	–	–	–
	M160×3	118	6,27	H24032-HG	KML32	MBL32	160	190	27,5	M6	4,2	7
	M160×3	119	7,81	H3132	KM32	MB32	160	210	27,5	–	–	–
	M160×3	119	7,81	H3132-HG	KM32	MB32	160	210	27,5	M6	4,2	7
	M160×3	147	9,32	H2332	KM32	MB32	160	210	27,5	–	–	–
	M160×3	147	9,32	H2332-HG	KM32	MB32	160	210	27,5	M6	4,2	7
	M160×3	148	8,66	H24132	KM32	MB32	160	210	27,5	–	–	–
	M160×3	148	8,66	H24132-HG	KM32	MB32	160	210	27,5	M6	4,2	7
	M160×3	170	10,7	H3332	KM32	MB32	160	210	27,5	–	–	–
M160×3	170	10,7	H3332-HG	KM32	MB32	160	210	27,5	M6	4,2	7	
150	M170×3	79	5,16	H3934	KML34	MBL34	170	200	28,5	–	–	–
	M170×3	79	5,16	H3934-HG	KML34	MBL34	170	200	28,5	M6	4,2	7
	M170×3	101	6,25	H3034	KML34	MBL34	170	200	28,5	–	–	–
	M170×3	101	6,25	H3034-HG	KML34	MBL34	170	200	28,5	M6	4,2	7
	M170×3	130	7,28	H24034	KML34	MBL34	170	200	28,5	–	–	–
	M170×3	130	7,28	H24034-HG	KML34	MBL34	170	200	28,5	M6	4,2	7
	M170×3	122	8,6	H3134	KM34	MB34	170	220	28,5	–	–	–
	M170×3	122	8,6	H3134-HG	KM34	MB34	170	220	28,5	M6	4,2	7
	M170×3	149	9,32	H24134	KM34	MB34	170	220	28,5	–	–	–
	M170×3	149	9,32	H24134-HG	KM34	MB34	170	220	28,5	M6	4,2	7
	M170×3	154	10,4	H2334	KM34	MB34	170	220	28,5	–	–	–
	M170×3	154	10,4	H2334-HG	KM34	MB34	170	220	28,5	M6	4,2	7
	M170×3	175	11,7	H3334	KM34	MB34	170	220	28,5	–	–	–
	M170×3	175	11,7	H3334-HG	KM34	MB34	170	220	28,5	M6	4,2	7

medias ▶ <https://www.schaeffler.de/std/1E9C>





Adapter sleeves

With locknut and retainer

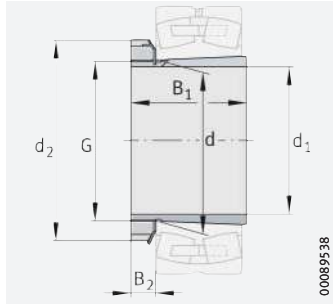

Taper 1:12
(taper 1:30 for H240, H241)
Tab washer MB, MBL

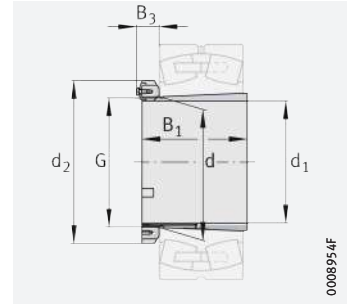

Taper 1:12
(taper 1:30 for H240)
Retaining bracket MS30

d₁ = 160 – 200 mm

Main dimensions			Mass m ≈ kg	Designation ▶ 1698 1.4			Dimensions			Mounting dimensions		
d ₁	G	B ₁		Adapter sleeve Complete	Locknut	Retainer	d	d ₂	B ₂	G ₁	a	l _{G1}
160	M180×3	87	6,01	H3936	KML36	MBL36	180	210	29,5	–	–	–
	M180×3	87	6,01	H3936-HG	KML36	MBL36	180	210	29,5	M6	4,2	7
	M180×3	109	7,18	H3036	KML36	MBL36	180	210	29,5	–	–	–
	M180×3	109	7,1	H3036-HG	KML36	MBL36	180	210	29,5	M6	4,2	7
	M180×3	140	8,33	H24036	KML36	MBL36	180	210	29,5	–	–	–
	M180×3	140	8,33	H24036-HG	KML36	MBL36	180	210	29,5	M6	4,2	7
	M180×3	131	9,8	H3136	KM36	MB36	180	230	29,5	–	–	–
	M180×3	131	9,7	H3136-HG	KM36	MB36	180	230	29,5	M6	4,2	7
	M180×3	159	10,5	H24136	KM36	MB36	180	230	29,5	–	–	–
	M180×3	159	10,5	H24136-HG	KM36	MB36	180	230	29,5	M6	4,2	7
	M180×3	161	11,6	H2336	KM36	MB36	180	230	29,5	–	–	–
	M180×3	161	11,6	H2336-HG	KM36	MB36	180	230	29,5	M6	4,2	7
	M180×3	186	13,3	H3336	KM36	MB36	180	230	29,5	–	–	–
	M180×3	186	13,3	H3336-HG	KM36	MB36	180	230	29,5	M6	4,2	7
170	M190×3	89	6,49	H3938	KML38	MBL38	190	220	30,5	–	–	–
	M190×3	89	6,49	H3938-HG	KML38	MBL38	190	220	30,5	M6	4,2	7
	M190×3	112	7,8	H3038	KML38	MBL38	190	220	30,5	–	–	–
	M190×3	112	7,8	H3038-HG	KML38	MBL38	190	220	30,5	M6	4,2	7
	M190×3	143	9	H24038	KML38	MBL38	190	220	30,5	–	–	–
	M190×3	143	9	H24038-HG	KML38	MBL38	190	220	30,5	M6	4,2	7
	M190×3	141	11,1	H3138	KM38	MB38	190	240	30,5	–	–	–
	M190×3	141	11	H3138-HG	KM38	MB38	190	240	30,5	M6	4,2	7
	M190×3	169	12,9	H2338	KM38	MB38	190	240	30,5	–	–	–
	M190×3	169	12,9	H2338-HG	KM38	MB38	190	240	30,5	M6	4,2	7
	M190×3	172	11,9	H24138	KM38	MB38	190	240	30,5	–	–	–
	M190×3	172	11,9	H24138-HG	KM38	MB38	190	240	30,5	M6	4,2	7
	M190×3	193	14,7	H3338	KM38	MB38	190	240	30,5	–	–	–
	M190×3	193	14,7	H3338-HG	KM38	MB38	190	240	30,5	M6	4,2	7

medias ▶ <https://www.schaeffler.de/std/1E9D>

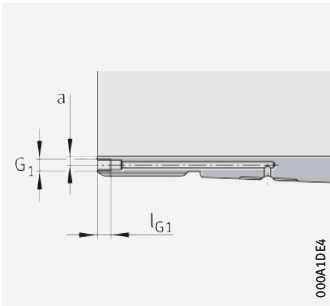

Hydraulic adapter sleeve
(suffix HG)
Mounting dimensions

Main dimensions			Mass m ≈ kg	Designation ▶ 1698 1.4			Dimensions				Mounting dimensions		
d_1	G	B_1		Adapter sleeve Complete	Locknut	Retainer	d	d_2	B_2	B_3	G_1	a	l_{G1}
180	M200×3	98	8,2	H3940	KML40	MBL40	200	240	31,5	–	–	–	–
	M200×3	98	8,14	H3940-HG	KML40	MBL40	200	240	31,5	–	M6	4,2	7
	M200×3	120	9,5	H3040	KML40	MBL40	200	240	31,5	–	–	–	–
	M200×3	120	9,5	H3040-HG	KML40	MBL40	200	240	31,5	–	M6	4,2	7
	M200×3	153	10,9	H24040	KML40	MBL40	200	240	31,5	–	–	–	–
	M200×3	153	10,8	H24040-HG	KML40	MBL40	200	240	31,5	–	M6	4,2	7
	M200×3	150	12,5	H3140	KM40	MB40	200	250	31,5	–	–	–	–
	M200×3	150	12,3	H3140-HG	KM40	MB40	200	250	31,5	–	M6	4,2	7
	M200×3	176	14,2	H2340	KM40	MB40	200	250	31,5	–	–	–	–
	M200×3	176	14,2	H2340-HG	KM40	MB40	200	250	31,5	–	M6	4,2	7
	M200×3	185	13,4	H24140	KM40	MB40	200	250	31,5	–	–	–	–
	M200×3	185	13,4	H24140-HG	KM40	MB40	200	250	31,5	–	M6	4,2	7
	M200×3	204	16,4	H3340	KM40	MB40	200	250	31,5	–	–	–	–
M200×3	204	16,4	H3340-HG	KM40	MB40	200	250	31,5	–	M6	4,2	7	
200	Tr220×4	96	8,45	H3944	HM3044	MS3044	220	260	–	39	–	–	–
	Tr220×4	96	8,45	H3944-HG	HM3044	MS3044	220	260	–	39	M6	4,2	7
	Tr220×4	126	10,5	H3044X	HM3044	MS3044	220	260	–	39	–	–	–
	Tr220×4	126	10,5	H3044X-HG	HM3044	MS3044	220	260	–	39	M6	4,2	7
	Tr220×4	162	12,1	H24044	HM3044	MS3044	220	260	–	39	–	–	–
	Tr220×4	162	12,4	H24044-HG	HM3044	MS3044	220	260	–	39	M6	4,2	7
	Tr220×4	161	16	H3144X	HM44T	MB44	220	280	35	–	–	–	–
	Tr220×4	161	15,7	H3144X-HG	HM44T	MB44	220	280	35	–	M6	4,2	7
	Tr220×4	186	17,8	H2344X	HM44T	MB44	220	280	35	–	–	–	–
	Tr220×4	186	17,8	H2344X-HG	HM44T	MB44	220	280	35	–	M6	4,2	7
	Tr220×4	199	17,1	H24144	HM44T	MB44	220	280	35	–	–	–	–
	Tr220×4	199	17,3	H24144-HG	HM44T	MB44	220	280	35	–	M6	4,2	7
	Tr220×4	223	21,1	H3344	HM44T	MB44	220	280	35	–	–	–	–
	Tr220×4	223	21,4	H3344-HG	HM44T	MB44	220	280	35	–	M6	4,2	7

medias ▶ <https://www.schaeffler.de/std/1E9E>



Adapter sleeves

With locknut and retainer

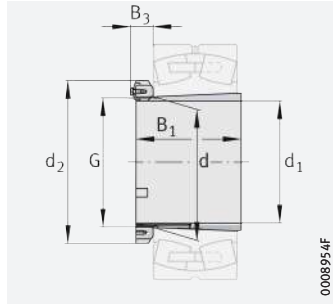

Taper 1:12
(taper 1:30 for H240, H241)
Retaining bracket MS30, MS31

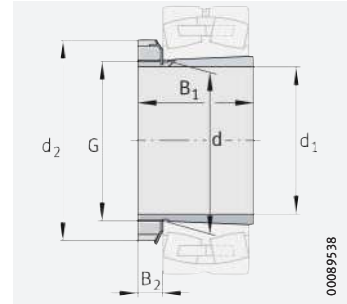

Taper 1:12
(taper 1:30 for H241)
Tab washer MB

$d_1 = 220 - 300 \text{ mm}$

Main dimensions			Mass m ≈ kg	Designation ▶ 1698 1.4			Dimensions				Mounting dimensions		
d_1	G	B_1		Adapter sleeve Complete	Locknut	Retainer	d	d_2	B_2	B_3	G_1	a	l_{G1}
								≈	≈				
220	Tr240×4	101	11,3	H3948	HM3048	MS3048	240	290	–	45	–	–	–
	Tr240×4	101	11,3	H3948-HG	HM3048	MS3048	240	290	–	45	M6	4,2	7
	Tr240×4	133	13,7	H3048	HM3048	MS3048	240	290	–	45	–	–	–
	Tr240×4	133	13,8	H3048-HG	HM3048	MS3048	240	290	–	45	M6	4,2	7
	Tr240×4	167	15,3	H24048	HM3048	MS3048	240	290	–	45	–	–	–
	Tr240×4	167	15,3	H24048-HG	HM3048	MS3048	240	290	–	45	M6	4,2	7
	Tr240×4	172	18,7	H3148X	HM48T	MB48	240	300	37	–	–	–	–
	Tr240×4	172	18,6	H3148X-HG	HM48T	MB48	240	300	37	–	M6	4,2	7
	Tr240×4	199	20,9	H2348X	HM48T	MB48	240	300	37	–	–	–	–
	Tr240×4	199	20,9	H2348X-HG	HM48T	MB48	240	300	37	–	M6	4,2	7
	Tr240×4	212	19,9	H24148	HM48T	MB48	240	300	37	–	–	–	–
	Tr240×4	212	19,9	H24148-HG	HM48T	MB48	240	300	37	–	M6	4,2	7
	Tr240×4	240	25,1	H3348	HM48T	MB48	240	300	37	–	–	–	–
	Tr240×4	240	25,1	H3348-HG	HM48T	MB48	240	300	37	–	M6	4,2	7
240	Tr260×4	116	13,6	H3952	HM3052	MS3048	260	310	–	45	–	–	–
	Tr260×4	116	13,6	H3952-HG	HM3052	MS3048	260	310	–	45	M6	4,2	7
	Tr260×4	145	16	H3052X	HM3052	MS3048	260	310	–	45	–	–	–
	Tr260×4	145	16	H3052X-HG	HM3052	MS3048	260	310	–	45	M6	4,2	7
	Tr260×4	190	18,4	H24052	HM3052	MS3048	260	310	–	45	–	–	–
	Tr260×4	190	18,4	H24052-HG	HM3052	MS3048	260	310	–	45	M6	4,2	7
	Tr260×4	190	23,5	H3152X	HM52T	MB52	260	330	38	–	–	–	–
	Tr260×4	190	23,6	H3152X-HG	HM52T	MB52	260	330	38	–	M6	4,2	7
	Tr260×4	211	25,7	H2352X	HM52T	MB52	260	330	38	–	–	–	–
	Tr260×4	211	25,8	H2352X-HG	HM52T	MB52	260	330	38	–	M6	4,2	7
	Tr260×4	235	25,2	H24152	HM52T	MB52	260	330	38	–	–	–	–
	Tr260×4	235	25,2	H24152-HG	HM52T	MB52	260	330	38	–	M6	4,2	7
	Tr260×4	253	30,5	H3352	HM52T	MB52	260	330	38	–	–	–	–
	Tr260×4	253	30,5	H3352-HG	HM52T	MB52	260	330	38	–	M6	4,2	7

medias ▶ <https://www.schaeffler.de/std/1E9F>

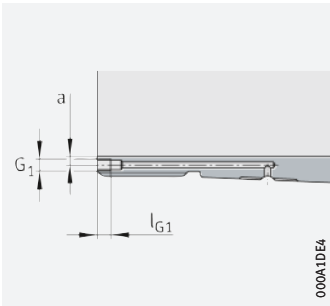

Hydraulic adapter sleeve
(suffix HG)
Mounting dimensions

Main dimensions			Mass m ≈ kg	Designation ▶ 1698 1.4			Dimensions				Mounting dimensions		
d_1	G	B_1		Adapter sleeve Complete	Locknut	Retainer	d	d_2	B_2	B_3	G_1	a	l_{G1}
260	Tr280×4	121	15,6	H3956	HM3056	MS3056	280	330	-	49	-	-	-
	Tr280×4	121	15,6	H3956-HG	HM3056	MS3056	280	330	-	49	M6	4,2	7
	Tr280×4	152	18,5	H3056	HM3056	MS3056	280	330	-	49	-	-	-
	Tr280×4	152	18,5	H3056-HG	HM3056	MS3056	280	330	-	49	M6	4,2	7
	Tr280×4	195	20,9	H24056	HM3056	MS3056	280	330	-	49	-	-	-
	Tr280×4	195	20,7	H24056-HG	HM3056	MS3056	280	330	-	49	M6	4,2	7
	Tr280×4	195	26,3	H3156X	HM56T	MB56	280	350	39	-	-	-	-
	Tr280×4	195	26,2	H3156X-HG	HM56T	MB56	280	350	39	-	M6	4,2	7
	Tr280×4	224	29,8	H2356X	HM56T	MB56	280	350	39	-	-	-	-
	Tr280×4	224	29,8	H2356X-HG	HM56T	MB56	280	350	39	-	M6	4,2	7
	Tr280×4	238	28	H24156	HM56T	MB56	280	350	39	-	-	-	-
	Tr280×4	238	28	H24156-HG	HM56T	MB56	280	350	39	-	M6	4,2	7
	Tr280×4	273	36	H3356	HM56T	MB56	280	350	39	-	-	-	-
	Tr280×4	273	36	H3356-HG	HM56T	MB56	280	350	39	-	M6	4,2	7
280	Tr300×4	140	20,9	H3960	HM3060	MS3060	300	360	-	53	-	-	-
	Tr300×4	140	20,9	H3960-HG	HM3060	MS3060	300	360	-	53	M6	4,2	7
	Tr300×4	168	23,8	H3060	HM3060	MS3060	300	360	-	53	-	-	-
	Tr300×4	168	23,7	H3060-HG	HM3060	MS3060	300	360	-	53	M6	4,2	7
	Tr300×4	220	26,9	H24060	HM3060	MS3060	300	360	-	53	-	-	-
	Tr300×4	220	26,9	H24060-HG	HM3060	MS3060	300	360	-	53	M6	4,2	7
	Tr300×4	208	30,6	H3160	HM3160	MS3160	300	380	-	52	-	-	-
	Tr300×4	208	31,1	H3160-HG	HM3160	MS3160	300	380	-	52	M6	4,2	7
	Tr300×4	240	34,7	H3260	HM3160	MS3160	300	380	-	52	-	-	-
	Tr300×4	240	35,1	H3260-HG	HM3160	MS3160	300	380	-	52	M6	4,2	7
	Tr300×4	258	32,7	H24160	HM3160	MS3160	300	380	-	52	-	-	-
	Tr300×4	258	32,7	H24160-HG	HM3160	MS3160	300	380	-	52	M6	4,2	7
	Tr300×4	284	40,8	H3360	HM3160	MS3160	300	380	-	52	-	-	-
	Tr300×4	284	40,8	H3360-HG	HM3160	MS3160	300	380	-	52	M6	4,2	7
300	Tr320×5	140	22,1	H3964-HG	HM3064	MS3064	320	380	-	54	M6	3,5	7
	Tr320×5	171	25,7	H3064-HG	HM3064	MS3064	320	380	-	54	M6	3,5	7
	Tr320×5	220	28,4	H24064-HG	HM3064	MS3064	320	380	-	54	M6	3,5	7
	Tr320×5	226	36,2	H3164-HG	HM3164	MS3164	320	400	-	55	M6	3,5	7
	Tr320×5	258	40,6	H3264-HG	HM3164	MS3164	320	400	-	55	M6	3,5	7
	Tr320×5	278	37,4	H24164-HG	HM3164	MS3164	320	400	-	55	M6	3,5	7
	Tr320×5	308	47,8	H3364-HG	HM3164	MS3164	320	400	-	55	M6	3,5	7

medias ▶ <https://www.schaeffler.de/std/1EAO>



Adapter sleeves

With locknut and retainer

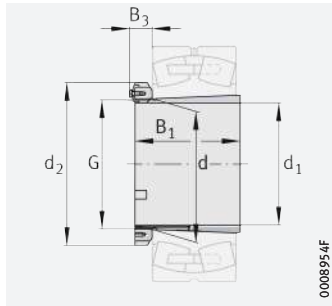

Taper 1:12
(taper 1:30 for H240, H241)
Retaining bracket MS30, MS31

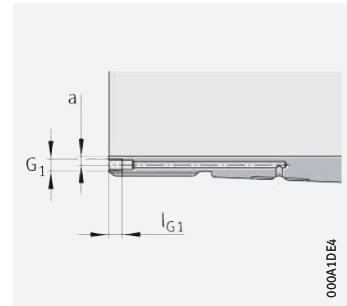

Hydraulic adapter sleeve
(suffix HG)
Mounting dimensions

$d_1 = 320 - 500 \text{ mm}$

Main dimensions			Mass m ≈ kg	Designation ▶ 1698 1.4			Dimensions			Mounting dimensions		
d_1	G	B_1		Adapter sleeve Complete	Locknut	Retainer	d	d_2	B_3	G_1	a	l_{G1}
320	Tr340×5	144	24,8	H3968-HG	HM3068	MS3064	340	400	57	M6	3,5	7
	Tr340×5	187	30	H3068-HG	HM3068	MS3064	340	400	57	M6	3,5	7
	Tr340×5	244	33,8	H24068-HG	HM3068	MS3064	340	400	57	M6	3,5	7
	Tr340×5	254	51,8	H3168-HG	HM3168	MS3168	340	440	70	M6	3,5	7
	Tr340×5	288	57,2	H3268-HG	HM3168	MS3168	340	440	70	M6	3,5	7
	Tr340×5	317	53	H24168-HG	HM3168	MS3168	340	440	70	M6	3,5	7
	Tr340×5	336	63,6	H3368-HG	HM3168	MS3168	340	440	70	M6	3,5	7
340	Tr360×5	144	25,9	H3972-HG	HM3072	MS3072	360	420	57	M6	3,5	7
	Tr360×5	188	31,6	H3072-HG	HM3072	MS3072	360	420	57	M6	3,5	7
	Tr360×5	244	35,6	H24072-HG	HM3072	MS3072	360	420	57	M6	3,5	7
	Tr360×5	259	54,3	H3172-HG	HM3172	MS3168	360	460	73	M6	3,5	7
	Tr360×5	299	63,8	H3272-HG	HM3172	MS3168	360	460	73	M6	3,5	7
	Tr360×5	321	59,9	H24172-HG	HM3172	MS3168	360	460	73	M6	3,5	7
	Tr360×5	357	71,8	H3372-HG	HM3172	MS3168	360	460	73	M6	3,5	7
360	Tr380×5	164	32,1	H3976-HG	HM3076	MS3076	380	450	61	M6	3,5	7
	Tr380×5	193	36,2	H3076-HG	HM3076	MS3076	380	450	61	M6	3,5	7
	Tr380×5	248	40,1	H24076-HG	HM3076	MS3076	380	450	61	M6	3,5	7
	Tr380×5	264	64,1	H3176-HG	HM3176	MS3176	380	490	75	M6	3,5	7
	Tr380×5	310	72,4	H3276-HG	HM3176	MS3176	380	490	75	M6	3,5	7
	Tr380×5	323	64,9	H24176-HG	HM3176	MS3176	380	490	75	M6	3,5	7
	Tr380×5	370	82,8	H3376-HG	HM3176	MS3176	380	490	75	M6	3,5	7
380	Tr400×5	168	35,4	H3980-HG	HM3080	MS3076	400	470	65	M6	3,5	7
	Tr400×5	210	41,7	H3080-HG	HM3080	MS3076	400	470	65	M6	3,5	7
	Tr400×5	272	46,4	H24080-HG	HM3080	MS3076	400	470	65	M6	3,5	7
	Tr400×5	272	71,3	H3180-HG	HM3180	MS3180	400	520	80	M6	3,5	7
	Tr400×5	328	83,7	H3280-HG	HM3180	MS3180	400	520	80	M6	3,5	7
	Tr400×5	332	73,8	H24180-HG	HM3180	MS3180	400	520	80	M6	3,5	7
	Tr400×5	380	93,4	H3380-HG	HM3180	MS3180	400	520	80	M6	3,5	7
400	Tr420×5	168	38,6	H3984-HG	HM3084	MS3084	420	490	65	M6	3,5	7
	Tr420×5	212	45,7	H3084X-HG	HM3084	MS3084	420	490	65	M6	3,5	7
	Tr420×5	274	48,6	H24084-HG	HM3084	MS3084	420	490	65	M6	3,5	7
	Tr420×5	304	88,4	H3184-HG	HM3184	MS3180	420	540	88	M6	3,5	7
	Tr420×5	352	98,7	H3284-HG	HM3184	MS3180	420	540	88	M6	3,5	7
	Tr420×5	372	87,8	H24184-HG	HM3184	MS3180	420	540	88	M6	3,5	7
	Tr420×5	395	105	H3384-HG	HM3184	MS3180	420	540	88	M6	3,5	7

medias ▶ <https://www.schaeffler.de/std/1EA1>



Main dimensions			Mass m ≈ kg	Designation ▶ 1698 1.4			Dimensions			Mounting dimensions		
d ₁	G	B ₁		Adapter sleeve Complete	Locknut	Retainer	d	d ₂	B ₃	G ₁	a	l _{G1}
410	Tr440×5	189	59	H3988-HG	HM3088	MS3088	440	520	75	M8	6,5	12
	Tr440×5	228	67,7	H3088-HG	HM3088	MS3088	440	520	75	M8	6,5	12
	Tr440×5	294	76,4	H24088-HG	HM3088	MS3088	440	520	75	M8	6,5	12
	Tr440×5	307	108	H3188-HG	HM3188	MS3188	440	560	88	M8	6,5	12
	Tr440×5	361	123	H3288-HG	HM3188	MS3188	440	560	88	M8	6,5	12
	Tr440×5	372	111	H24188-HG	HM3188	MS3188	440	560	88	M8	6,5	12
	Tr440×5	426	140	H3388-HG	HM3188	MS3188	440	560	88	M8	6,5	12
430	Tr460×5	189	62,4	H3992-HG	HM3092	MS3088	460	540	75	M8	6,5	12
	Tr460×5	234	71,8	H3092-HG	HM3092	MS3088	460	540	75	M8	6,5	12
	Tr460×5	300	80,8	H24092-HG	HM3092	MS3088	460	540	75	M8	6,5	12
	Tr460×5	326	118	H3192-HG	HM3192	MS3188	460	580	93	M8	6,5	12
	Tr460×5	382	138,9	H3292-HG	HM3192	MS3188	460	580	93	M8	6,5	12
	Tr460×5	398	124	H24192-HG	HM3192	MS3188	460	580	93	M8	6,5	12
	Tr460×5	451	157	H3392-HG	HM3192	MS3188	460	580	93	M8	6,5	12
450	Tr480×5	200	66,8	H3996-HG	HM3096	MS3096	480	560	75	M8	6,5	12
	Tr480×5	237	76,8	H3096-HG	HM3096	MS3096	480	560	75	M8	6,5	12
	Tr480×5	301	85,6	H24096-HG	HM3096	MS3096	480	560	75	M8	6,5	12
	Tr480×5	335	135	H3196-HG	HM3196	MS3196	480	620	93	M8	6,5	12
	Tr480×5	397	159,2	H3296-HG	HM3196	MS3196	480	620	93	M8	6,5	12
	Tr480×5	408	142	H24196-HG	HM3196	MS3196	480	620	93	M8	6,5	12
	Tr480×5	462	177	H3396-HG	HM3196	MS3196	480	620	93	M8	6,5	12
470	Tr500×5	208	76,1	H39/500-HG	HM30/500	MS3096	500	580	83	M8	6,5	12
	Tr500×5	247	85,2	H30/500-HG	HM30/500	MS3096	500	580	83	M8	6,5	12
	Tr500×5	309	93,8	H240/500-HG	HM30/500	MS3096	500	580	83	M8	6,5	12
	Tr500×5	356	149,9	H31/500-HG	HM31/500	MS31/500	500	630	98	M8	6,5	12
	Tr500×5	428	174,5	H32/500-HG	HM31/500	MS31/500	500	630	98	M8	6,5	12
	Tr500×5	430	155,8	H241/500-HG	HM31/500	MS31/500	500	630	98	M8	6,5	12
	Tr500×5	480	189	H33/500-HG	HM31/500	MS31/500	500	630	98	M8	6,5	12
500	Tr530×6	216	91,6	H39/530-HG	HM30/530	MS30/530	530	630	88	M8	6	12
	Tr530×6	265	103	H30/530-HG	HM30/530	MS30/530	530	630	88	M8	6	12
	Tr530×6	343	115	H240/530-HG	HM30/530	MS30/530	530	630	88	M8	6	12
	Tr530×6	364	161	H31/530-HG	HM31/530	MS31/530	530	670	102	M8	6	12
	Tr530×6	440	167	H241/530-HG	HM31/530	MS31/530	530	670	102	M8	6	12
	Tr530×6	447	192	H32/530-HG	HM31/530	MS31/530	530	670	102	M8	6	12
	Tr530×6	504	215	H33/530-HG	HM31/530	MS31/530	530	670	102	M8	6	12

medias ▶ <https://www.schaeffler.de/std/1EA2>



Adapter sleeves

With locknut and retainer

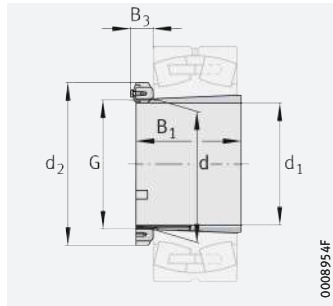

Taper 1:12
(taper 1:30 for H240, H241)
Retaining bracket MS30, MS31

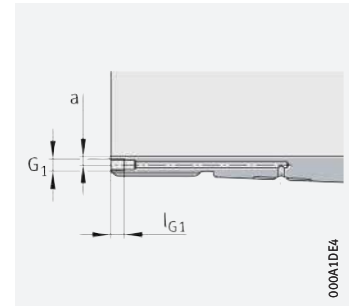

Hydraulic adapter sleeve
(suffix HG)
Mounting dimensions

$d_1 = 530 - 900 \text{ mm}$

Main dimensions			Mass m ≈ kg	Designation ▶ 1698 1.4			Dimensions			Mounting dimensions		
d_1	G	B_1		Adapter sleeve Complete	Locknut	Retainer	d	d_2	B_3	G_1	a	l_{G1}
530	Tr560×6	227	98,5	H39/560-HG	HM30/560	MS30/560	560	650	95	M8	6	12
	Tr560×6	282	112	H30/560-HG	HM30/560	MS30/560	560	650	95	M8	6	12
	Tr560×6	358	124	H240/560-HG	HM30/560	MS30/560	560	650	95	M8	6	12
	Tr560×6	377	184	H31/560-HG	HM31/560	MS31/560	560	710	107	M8	6	12
	Tr560×6	462	218	H32/560-HG	HM31/560	MS31/560	560	710	107	M8	6	12
	Tr560×6	468	195	H241/560-HG	HM31/560	MS31/560	560	710	107	M8	6	12
	Tr560×6	535	250	H33/560-HG	HM31/560	MS31/560	560	710	107	M8	6	12
560	Tr600×6	239	132,2	H39/600-HG	HM30/600	MS30/530	600	700	95	$G^{1/8}$	8	12
	Tr600×6	289	152,3	H30/600-HG	HM30/600	MS30/530	600	700	95	$G^{1/8}$	8	12
	Tr600×6	377	171	H240/600-HG	HM30/600	MS30/530	600	700	95	$G^{1/8}$	8	12
	Tr600×6	399	241,8	H31/600-HG	HM31/600	MS31/560	600	750	108	$G^{1/8}$	8	12
	Tr600×6	487	279	H32/600-HG	HM31/600	MS31/560	600	750	108	$G^{1/8}$	8	12
	Tr600×6	490	249	H241/600-HG	HM31/600	MS31/560	600	750	108	$G^{1/8}$	8	12
	Tr600×6	561	320	H33/600-HG	HM31/600	MS31/560	600	750	108	$G^{1/8}$	8	12
600	Tr630×6	254	126,3	H39/630-HG	HM30/630	MS30/630	630	730	95	M8	6	12
	Tr630×6	301	143,1	H30/630-HG	HM30/630	MS30/630	630	730	95	M8	6	12
	Tr630×6	395	157	H240/630-HG	HM30/630	MS30/630	630	730	95	M8	6	12
	Tr630×6	424	261,9	H31/630-HG	HM31/630	MS31/630	630	800	118	M8	6	12
	Tr630×6	521	297	H32/630-HG	HM31/630	MS31/630	630	800	118	M8	6	12
	Tr630×6	525	273,1	H241/630-HG	HM31/630	MS31/630	630	800	118	M8	6	12
	Tr630×6	597	338	H33/630-HG	HM31/630	MS31/630	630	800	118	M8	6	12
630	Tr670×6	264	166	H39/670-HG	HM30/670	MS30/670	670	780	101	$G^{1/8}$	8	12
	Tr670×6	324	194	H30/670-HG	HM30/670	MS30/670	670	780	101	$G^{1/8}$	8	12
	Tr670×6	418	218	H240/670-HG	HM30/670	MS30/670	670	780	101	$G^{1/8}$	8	12
	Tr670×6	456	353,3	H31/670-HG	HM31/670	MS31/670	670	850	129	$G^{1/8}$	8	12
	Tr670×6	548	355	H241/670-HG	HM31/670	MS31/670	670	850	129	$G^{1/8}$	8	12
	Tr670×6	558	402	H32/670-HG	HM31/670	MS31/670	670	850	129	$G^{1/8}$	8	12
	Tr670×6	635	453	H33/670-HG	HM31/670	MS31/670	670	850	129	$G^{1/8}$	8	12
670	Tr710×7	286	206	H39/710-HG	HM30/710	MS30/710	710	830	110	$G^{1/8}$	8	12
	Tr710×7	342	234,2	H30/710-HG	HM30/710	MS30/710	710	830	110	$G^{1/8}$	8	12
	Tr710×7	438	254	H240/710-HG	HM30/710	MS30/710	710	830	110	$G^{1/8}$	8	12
	Tr710×7	467	376	H31/710-HG	HM31/710	MS31/710	710	900	132	$G^{1/8}$	8	12
	Tr710×7	572	444	H32/710-HG	HM31/710	MS31/710	710	900	132	$G^{1/8}$	8	12
	Tr710×7	577	412,1	H241/710-HG	HM31/710	MS31/710	710	900	132	$G^{1/8}$	8	12
	Tr710×7	652	501	H33/710-HG	HM31/710	MS31/710	710	900	132	$G^{1/8}$	8	12

medias ▶ <https://www.schaeffler.de/std/1EA3>



Main dimensions			Mass m ≈ kg	Designation ▶ 1698 1.4			Dimensions			Mounting dimensions		
d ₁	G	B ₁		Adapter sleeve Complete	Locknut	Retainer	d	d ₂	B ₃ ≈	G ₁	a	l _{G1}
710	Tr750×7	291	219,6	H39/750-HG	HM30/750	MS30/750	750	870	110	G ¹ / ₈	8	12
	Tr750×7	356	248	H30/750-HG	HM30/750	MS30/750	750	870	110	G ¹ / ₈	8	12
	Tr750×7	460	278	H240/750-HG	HM30/750	MS30/750	750	870	110	G ¹ / ₈	8	12
	Tr750×7	493	432	H31/750-HG	HM31/750	MS31/750	750	950	137	G ¹ / ₈	8	12
	Tr750×7	603	508	H32/750-HG	HM31/750	MS31/750	750	950	137	G ¹ / ₈	8	12
	Tr750×7	622	461	H241/750-HG	HM31/750	MS31/750	750	950	137	G ¹ / ₈	8	12
	Tr750×7	688	574	H33/750-HG	HM31/750	MS31/750	750	950	137	G ¹ / ₈	8	12
750	Tr800×7	303	268,9	H39/800-HG	HM30/800	MS30/750	800	920	110	G ¹ / ₈	10	12
	Tr800×7	366	311,6	H30/800-HG	HM30/800	MS30/750	800	920	110	G ¹ / ₈	10	12
	Tr800×7	475	349	H240/800-HG	HM30/800	MS30/750	800	920	110	G ¹ / ₈	10	12
	Tr800×7	505	515	H31/800-HG	HM31/800	MS31/750	800	1000	137	G ¹ / ₈	10	12
	Tr800×7	618	611	H32/800-HG	HM31/800	MS31/750	800	1000	137	G ¹ / ₈	10	12
	Tr800×7	627	552	H241/800-HG	HM31/800	MS31/750	800	1000	137	G ¹ / ₈	10	12
	Tr800×7	730	716	H33/800-HG	HM31/800	MS31/750	800	1000	137	G ¹ / ₈	10	12
800	Tr850×7	308	298,5	H39/850-HG	HM30/850	MS30/850	850	980	113	G ¹ / ₈	10	12
	Tr850×7	380	350,8	H30/850-HG	HM30/850	MS30/850	850	980	113	G ¹ / ₈	10	12
	Tr850×7	495	393	H240/850-HG	HM30/850	MS30/850	850	980	113	G ¹ / ₈	10	12
	Tr850×7	536	590	H31/850-HG	HM31/850	MS31/850	850	1060	144	G ¹ / ₈	10	12
	Tr850×7	651	696	H32/850-HG	HM31/850	MS31/850	850	1060	144	G ¹ / ₈	10	12
	Tr850×7	658	650,2	H241/850-HG	HM31/850	MS31/850	850	1060	144	G ¹ / ₈	10	12
	Tr850×7	766	814	H33/850-HG	HM31/850	MS31/850	850	1060	144	G ¹ / ₈	10	12
850	Tr900×7	326	335	H39/900-HG	HM30/900	MS30/850	900	1030	122	G ¹ / ₈	10	12
	Tr900×7	400	392	H30/900-HG	HM30/900	MS30/850	900	1030	122	G ¹ / ₈	10	12
	Tr900×7	520	446	H240/900-HG	HM30/900	MS30/850	900	1030	122	G ¹ / ₈	10	12
	Tr900×7	557	674	H31/900-HG	HM31/900	MS31/900	900	1120	150	G ¹ / ₈	10	12
	Tr900×7	660	775	H32/900-HG	HM31/900	MS31/900	900	1120	150	G ¹ / ₈	10	12
	Tr900×7	685	712	H241/900-HG	HM31/900	MS31/900	900	1120	150	G ¹ / ₈	10	12
	Tr900×7	795	923	H33/900-HG	HM31/900	MS31/900	900	1120	150	G ¹ / ₈	10	12
900	Tr950×8	344	369	H39/950-HG	HM30/950	MS30/950	950	1080	122	G ¹ / ₈	10	12
	Tr950×8	420	432	H30/950-HG	HM30/950	MS30/950	950	1080	122	G ¹ / ₈	10	12
	Tr950×8	557	499	H240/950-HG	HM30/950	MS30/950	950	1080	122	G ¹ / ₈	10	12
	Tr950×8	583	738	H31/950-HG	HM31/950	MS31/950	950	1170	151	G ¹ / ₈	10	12
	Tr950×8	675	835	H32/950-HG	HM31/950	MS31/950	950	1170	151	G ¹ / ₈	10	12
	Tr950×8	715	804,8	H241/950-HG	HM31/950	MS31/950	950	1170	151	G ¹ / ₈	10	12
	Tr950×8	815	1000	H33/950-HG	HM31/950	MS31/950	950	1170	151	G ¹ / ₈	10	12

medias ▶ <https://www.schaeffler.de/std/1EA4>



Adapter sleeves

With locknut and retainer

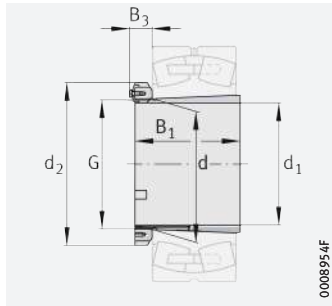

Taper 1:12
(taper 1:30 for H240, H241)
Retaining bracket MS30, MS31

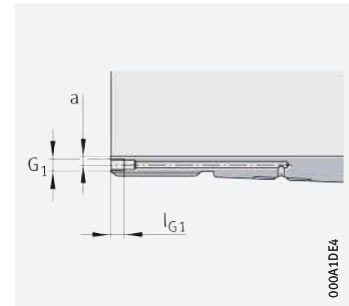

Hydraulic adapter sleeve
(suffix HG)
Mounting dimensions

$d_1 = 950 - 1\,600$ mm

Main dimensions			Mass m ≈ kg	Designation ► 1698 1.4			Dimensions			Mounting dimensions		
d_1	G	B_1		Adapter sleeve Complete	Locknut	Retainer	d	d_2	B_3 ≈	G_1	a	l_{G1}
950	Tr1000×8	358	410	H39/1000-HG	HM30/1000	MS30/1000	1 000	1 140	122	$G^{1/8}$	10	12
	Tr1000×8	430	474	H30/1000-HG	HM30/1000	MS30/1000	1 000	1 140	122	$G^{1/8}$	10	12
	Tr1000×8	562	539	H240/1000-HG	HM30/1000	MS30/1000	1 000	1 140	122	$G^{1/8}$	10	12
	Tr1000×8	609	840	H31/1000-HG	HM31/1000	MS31/1000	1 000	1 240	151	$G^{1/8}$	10	12
	Tr1000×8	707	952	H32/1000-HG	HM31/1000	MS31/1000	1 000	1 240	151	$G^{1/8}$	10	12
	Tr1000×8	755	886	H241/1000-HG	HM31/1000	MS31/1000	1 000	1 240	151	$G^{1/8}$	10	12
	Tr1000×8	857	1 140	H33/1000-HG	HM31/1000	MS31/1000	1 000	1 240	151	$G^{1/8}$	10	12
1 000	Tr1060×8	372	493	H39/1060-HG	HM30/1060	MS30/1000	1 060	1 200	122	$G^{1/4}$	12	15
	Tr1060×8	447	574	H30/1060-HG	HM30/1060	MS30/1000	1 060	1 200	122	$G^{1/4}$	12	15
	Tr1060×8	588	665	H240/1060-HG	HM30/1060	MS30/1000	1 060	1 200	122	$G^{1/4}$	12	15
	Tr1060×8	622	985	H31/1060-HG	HM31/1060	MS31/1000	1 060	1 300	151	$G^{1/4}$	12	15
	Tr1060×8	775	1 060	H241/1060-HG	HM31/1060	MS31/1000	1 060	1 300	151	$G^{1/4}$	12	15
1 060	Tr1120×8	372	521	H39/1120-HG	HM30/1120	MS30/1000	1 120	1 260	122	$G^{1/4}$	12	15
	Tr1120×8	467	631	H30/1120-HG	HM30/1120	MS30/1000	1 120	1 260	122	$G^{1/4}$	12	15
	Tr1120×8	612	728	H240/1120-HG	HM30/1120	MS30/1000	1 120	1 260	122	$G^{1/4}$	12	15
	Tr1120×8	622	1 060	H31/1120-HG	HM31/1120	MS31/1000	1 120	1 360	151	$G^{1/4}$	12	15
	Tr1120×8	805	1 170	H241/1120-HG	HM31/1120	MS31/1000	1 120	1 360	151	$G^{1/4}$	13	15
1 120	Tr1180×8	394	576	H39/1180-HG	HM30/1180	MS30/1000	1 180	1 320	122	$G^{1/4}$	12	15
	Tr1180×8	479	682	H30/1180-HG	HM30/1180	MS30/1000	1 180	1 320	122	$G^{1/4}$	12	15
	Tr1180×8	625	782	H240/1180-HG	HM30/1180	MS30/1000	1 180	1 320	122	$G^{1/4}$	12	15
	Tr1180×8	647	1 160	H31/1180-HG	HM31/1180	MS31/1000	1 180	1 420	151	$G^{1/4}$	12	15
	Tr1180×8	845	1 290	H241/1180-HG	HM31/1180	MS31/1000	1 180	1 420	151	$G^{1/4}$	13	15
1 180	Tr1250×8	407	708	H39/1250-HG	HM30/1250	MS30/1000	1 250	1 390	132	$G^{1/4}$	14	15
	Tr1250×8	509	858	H30/1250-HG	HM30/1250	MS30/1000	1 250	1 390	132	$G^{1/4}$	15	15
	Tr1250×8	660	988	H240/1250-HG	HM30/1250	MS30/1000	1 250	1 390	132	$G^{1/4}$	14	15
	Tr1250×8	677	1 380	H31/1250-HG	HM31/1250	MS31/1000	1 250	1 490	151	$G^{1/4}$	14	15
	Tr1250×8	885	1 549,6	H241/1250-HG	HM31/1250	MS31/1000	1 250	1 490	151	$G^{1/4}$	14	15
1 250	Tr1320×8	430	781	H39/1320-HG	HM30/1320	MS30/1000	1 320	1 460	132	$G^{1/4}$	14	15
	Tr1320×8	534	946	H30/1320-HG	HM30/1320	MS30/1000	1 320	1 460	132	$G^{1/4}$	15	15
	Tr1320×8	690	1 080	H240/1320-HG	HM30/1320	MS30/1000	1 320	1 460	132	$G^{1/4}$	14	15
	Tr1320×8	710	1 510	H31/1320-HG	HM31/1320	MS31/1000	1 320	1 560	151	$G^{1/4}$	14	15
	Tr1320×8	935	1 700	H241/1320-HG	HM31/1320	MS31/1000	1 320	1 560	151	$G^{1/4}$	14	15

medias ► <https://www.schaeffler.de/std/1EA5>



Main dimensions			Mass m ≈ kg	Designation ▶ 1698 1.4			Dimensions			Mounting dimensions		
d_1	G	B_1		Adapter sleeve Complete	Locknut	Retainer	d	d_2	B_3 ≈	G_1	a	l_{G1}
1 320	Tr1400×8	445	924	H39/1400-HG	HM30/1400	MS30/1000	1400	1540	132	$G^{1/4}$	15	15
	Tr1400×8	546	1 110	H30/1400-HG	HM30/1400	MS30/1000	1400	1540	132	$G^{1/4}$	15	15
	Tr1400×8	705	1 290	H240/1400-HG	HM30/1400	MS30/1000	1400	1540	132	$G^{1/4}$	14	15
	Tr1400×8	735	1 790	H31/1400-HG	HM31/1400	MS31/1000	1400	1640	156	$G^{1/4}$	15	15
	Tr1400×8	965	2 030	H241/1400-HG	HM31/1400	MS31/1000	1400	1640	156	$G^{1/4}$	15	15
1 400	Tr1500×8	465	1 210	H39/1500-HG	HM30/1500	MS30/1500	1500	1650	132	$G^{1/4}$	15	15
	Tr1500×8	600	1 530	H30/1500-HG	HM30/1500	MS30/1500	1500	1650	132	$G^{1/4}$	15	15
	Tr1500×8	775	1 790	H240/1500-HG	HM30/1500	MS30/1500	1500	1650	132	$G^{1/4}$	14	15
	Tr1500×8	755	2 230	H31/1500-HG	HM31/1500	MS31/1000	1500	1740	156	$G^{1/4}$	15	15
	Tr1500×8	990	2 560	H241/1500-HG	HM31/1500	MS31/1000	1500	1740	156	$G^{1/4}$	15	15
1 500	Tr1600×8	465	2 480	H39/1600-HG	Z-195077.01.HM	MS30/850	1600	1730	112	$G^{1/4}$	15	15
1 600	Tr1700×8	475	2 620	H39/1700-HG	Z-195078.01.HM	MS30/850	1700	1830	112	$G^{1/4}$	15	15

medias ▶ <https://www.schaeffler.de/std/1EA6>





Withdrawal sleeves

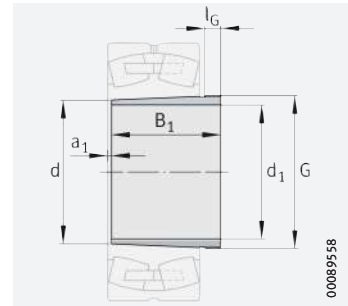

Taper 1:12
(taper 1:30 for AH240, AH241)

d₁ = 35 – 95 mm

Main dimensions			Mass m ≈ kg	Designation ▶ 1698 1.4	Dimensions		
d ₁	G	B ₁			d	a ₁ ≈	l _G
35	M45×1,5	25	0,08	AH208	40	2	6
	M45×1,5	29	0,09	AH308	40	3	6
	M45×1,5	40	0,13	AH2308	40	3	7
	M45×1,5	44	0,15	AH3308	40	3	7
40	M50×1,5	26	0,09	AH209	45	3	6
	M50×1,5	31	0,11	AH309	45	3	6
	M50×1,5	44	0,17	AH2309	45	3	7
	M50×1,5	47	0,18	AH3309	45	3	7
45	M55×2	28	0,12	AH210	50	3	7
	M55×2	35	0,14	AHX310	50	3	7
	M55×2	50	0,22	AHX2310	50	3	9
	M55×2	54	0,24	AH3310	50	3	9
50	M60×2	29	0,13	AH211	55	3	7
	M60×2	37	0,17	AHX311	55	3	7
	M60×2	54	0,26	AHX2311	55	3	10
	M60×2	60	0,3	AH3311	55	3	10
55	M65×2	32	0,16	AH212	60	3	8
	M65×2	40	0,2	AHX312	60	3	8
	M65×2	58	0,32	AHX2312	60	3	11
	M70×2	65	0,41	AH3312	60	3	11
60	M75×2	33	0,21	AH213	65	4	8
	M70×2	33	0,18	AH213G	65	4	8
	M75×2	42	0,27	AH313	65	3	8
	M70×2	42	0,23	AH313G	65	3	8
	M75×2	61	0,42	AH2313	65	3	12
	M70×2	61	0,36	AH2313G	65	3	12
	M75×2	71	0,49	AH3313	65	3	12
65	M80×2	34	0,23	AH214	70	4	8
	M75×2	34	0,2	AH214G	70	4	8
	M80×2	43	0,29	AH314	70	4	8
	M75×2	43	0,26	AH314G	70	4	8
	M80×2	64	0,47	AHX2314	70	4	12
	M75×2	64	0,42	AHX2314G	70	4	12
	M80×2	76	0,57	AH3314	70	4	12

medias ▶ <https://www.schaeffler.de/std/1EA7>



Main dimensions			Mass m ≈ kg	Designation ▶ 1698 1.4	Dimensions		
d_1	G	B_1			d	a_1 ≈	l_G
70	M85×2	35	0,26	AH215	75	4	8
	M80×2	35	0,22	AH215G	75	4	8
	M85×2	45	0,33	AH315	75	4	8
	M80×2	45	0,29	AH315G	75	4	8
	M85×2	68	0,54	AHX2315	75	4	12
	M80×2	68	0,48	AHX2315G	75	4	12
	M85×2	81	0,66	AH3315	75	4	12
75	M90×2	36	0,28	AH216	80	4	8
	M90×2	48	0,38	AH316	80	4	8
	M90×2	71	0,61	AHX2316	80	4	12
	M90×2	81	0,71	AH3316	80	4	12
80	M95×2	39	0,33	AH217	85	4	9
	M95×2	52	0,44	AHX317	85	4	9
	M95×2	60	0,52	AH3217	85	4	10
	M95×2	74	0,68	AHX2317	85	4	13
	M95×2	86	0,81	AH3317	85	4	13
85	M100×2	40	0,36	AH218	90	4	9
	M100×2	53	0,48	AHX318	90	4	9
	M100×2	63	0,58	AHX3218	90	4	10
	M100×2	79	0,78	AHX2318	90	4	14
	M100×2	87	0,88	AH3318	90	4	14
90	M105×2	43	0,42	AH219	95	4	10
	M105×2	57	0,55	AHX319	95	4	10
	M105×2	67	0,67	AHX3219	95	4	11
	M105×2	85	0,91	AHX2319	95	4	16
	M105×2	94	1,03	AH3319	95	4	16
95	M110×2	45	0,46	AH220	100	4	10
	M110×2	59	0,6	AHX320	100	4	10
	M105×2	62	0,5	AH24020	100	9	12
	M110×2	64	0,67	AHX3120	100	4	11
	M110×2	73	0,78	AHX3220	100	4	11
	M105×2	78	0,63	AH24120	100	9	13
	M110×2	90	1,03	AHX2320	100	4	16
	M110×2	99	1,16	AH3320	100	4	16

medias ▶ <https://www.schaeffler.de/std/1EA8>





Withdrawal sleeves

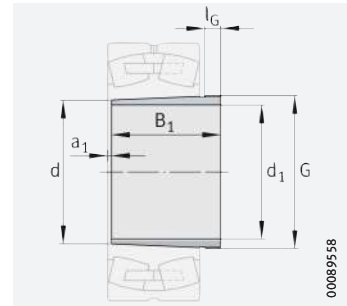

Taper 1:12
(taper 1:30 for AH240, AH241)

$d_1 = 105 - 145 \text{ mm}$

Main dimensions			Mass m ≈ kg	Designation ▶ 1698 1.4	Dimensions		
d_1	G	B_1			d	a_1 ≈	l_G
105	M120×2	50	0,57	AH222	110	4	11
	M120×2	63	0,73	AHX322	110	4	12
	M120×2	68	0,79	AHX3122	110	4	11
	M115×2	73	0,65	AH24022	110	9	13
	M115×2	82	0,73	AH24122	110	9	13
	M120×2	82	0,98	AHX3222A	110	4	11
	M125×2	98	1,38	AHX2322	110	4	16
	M120×2	98	1,26	AHX2322G	110	4	16
	M125×2	108	1,54	AH3322	110	4	16
115	M130×2	53	0,67	AH224	120	4	12
	M130×2	60	0,77	AHX3024	120	4	13
	M130×2	69	0,89	AHX324	120	4	13
	M125×2	73	0,71	AH24024	120	9	13
	M130×2	75	0,97	AHX3124	120	4	12
	M130×2	90	1,22	AHX3224A	120	4	13
	M130×2	93	1,02	AH24124	120	9	13
	M135×2	105	1,64	AHX2324	120	4	17
	M130×2	105	1,5	AHX2324G	120	4	17
	M135×2	123	1,99	AH3324	120	4	17
125	M140×2	53	0,72	AH226	130	4	12
	M140×2	67	0,94	AHX3026	130	4	14
	M140×2	74	1,05	AHX326	130	4	14
	M140×2	78	1,1	AHX3126	130	4	12
	M135×2	83	0,89	AH24026	130	10	14
	M140×2	94	1,13	AH24126	130	10	14
	M145×2	98	1,61	AHX3226	130	4	15
	M140×2	98	1,48	AHX3226G	130	4	15
	M145×2	115	2	AHX2326	130	4	19
	M140×2	115	1,84	AHX2326G	130	4	19
M145×2	131	2,36	AH3326	130	4	19	

medias ▶ <https://www.schaeffler.de/std/1EA9>



Main dimensions			Mass m ≈ kg	Designation ▶ 1698 1.4	Dimensions		
d_1	G	B_1			d	a_1 ≈	l_G
135	M150×2	56	0,83	AH228	140	5	13
	M150×2	68	1,03	AHX3028	140	5	14
	M150×2	77	1,18	AHX328	140	5	14
	M145×2	83	0,96	AH24028	140	10	14
	M150×2	83	1,29	AHX3128	140	5	14
	M150×2	99	1,29	AH24128	140	10	14
	M155×3	104	1,86	AHX3228	140	5	15
	M150×2	104	1,72	AHX3228G	140	5	15
	M155×3	125	2,4	AHX2328	140	5	20
	M150×2	125	2,21	AHX2328G	140	5	20
	M155×3	138	2,72	AH3328	140	5	20
145	M160×3	60	0,97	AH230	150	5	14
	M160×3	72	1,18	AHX3030	150	5	15
	M165×3	83	1,54	AHX330	150	5	15
	M160×3	83	1,39	AHX330G	150	5	15
	M155×3	90	1,12	AH24030	150	11	15
	M165×3	96	1,81	AHX3130	150	5	15
	M160×3	96	1,66	AHX3130G	150	5	15
	M165×3	114	2,25	AHX3230	150	5	17
	M160×3	114	2,09	AHX3230G	150	5	17
	M160×3	115	1,63	AH24130	150	11	15
	M165×3	135	2,88	AHX2330	150	5	24
	M160×3	135	2,64	AHX2330G	150	5	24
	M165×3	152	3,36	AH3330	150	5	24

medias ▶ <https://www.schaeffler.de/std/1EAA>





Withdrawal sleeves

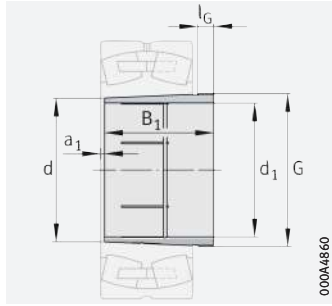

Hydraulic withdrawal sleeve
Taper 1:12
(taper 1:30 for AH240, AH241)

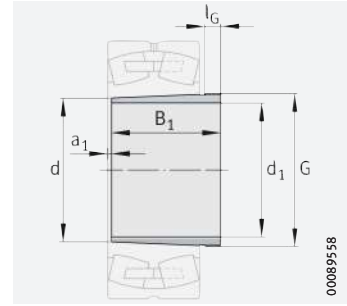

Taper 1:12
(taper 1:30 for AH240, AH241)

$d_1 = 150 - 160$ mm

Main dimensions			Mass m ≈ kg	Designation ▶ 1698 1.4	Dimensions			Mounting dimensions		
d_1	G	B_1			d	a_1 ≈	l_G	G_1	a	l_{G1}
150	M170×3	64	1,71	AH232	160	5	15	–	–	–
	M170×3	77	2,09	AH3032	160	5	16	–	–	–
	M170×3	77	2,09	AH3032-H	160	5	16	M6	4,2	7
	M180×3	88	2,76	AH332	160	5	16	–	–	–
	M170×3	88	2,42	AH332G	160	5	16	–	–	–
	M170×3	95	2,31	AH24032	160	11	15	–	–	–
	M170×3	95	2,27	AH24032-H	160	11	15	M6	4,2	7
	M170×3	103	2,9	AH3132A	160	5	16	–	–	–
	M170×3	103	2,9	AH3132A-H	160	5	16	M6	4,5	7
	M170×3	124	3,04	AH24132	160	11	15	–	–	–
	M180×3	124	4,08	AH3232	160	6	20	–	–	–
	M180×3	124	4,08	AH3232-H	160	6	20	M6	4,5	7
	M170×3	124	3,65	AH3232G	160	6	20	–	–	–
	M170×3	124	3,65	AH3232G-H	160	6	20	M6	4,5	7
	M180×3	140	4,77	AH2332	160	6	24	–	–	–
	M180×3	140	4,77	AH2332-H	160	6	24	M6	4,5	7
	M170×3	140	4,26	AH2332G	160	6	24	–	–	–
	M170×3	140	4,26	AH2332G-H	160	6	24	M6	4,5	7
	M180×3	160	5,58	AH3332	160	6	24	–	–	–
	M180×3	160	5,58	AH3332-H	160	6	24	M6	4,5	7

medias ▶ <https://www.schaeffler.de/std/1EAB>

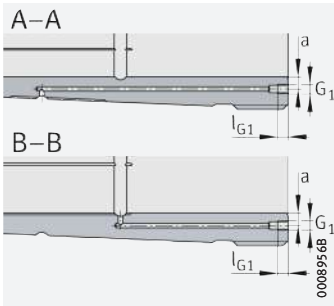

Hydraulic withdrawal sleeve
(suffix H)
Mounting dimensions

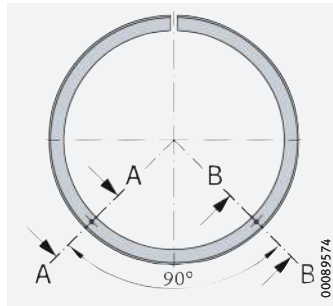

Oil connectors
for hydraulic withdrawal sleeve

Main dimensions			Mass m ≈ kg	Designation ▶ 1698 1.4	Dimensions			Mounting dimensions		
d_1	G	B_1			d	a_1 ≈	l_G	G_1	a	l_{G1}
160	M180×3	59	1,65	AH3934A	170	5	13	–	–	–
	M180×3	69	1,98	AH234	170	5	16	–	–	–
	M180×3	85	2,48	AH3034	170	5	17	–	–	–
	M180×3	85	2,48	AH3034-H	170	5	17	M6	4,2	7
	M190×3	93	3,13	AH334	170	5	17	–	–	–
	M180×3	93	2,75	AH334G	170	5	17	–	–	–
	M190×3	104	3,4	AH3134	170	5	16	–	–	–
	M190×3	104	3,4	AH3134-H	170	5	16	M6	4,5	7
	M180×3	104	3,12	AH3134A	170	5	16	–	–	–
	M180×3	104	3,12	AH3134A-H	170	5	16	M6	4,5	7
	M180×3	106	2,76	AH24034	170	11	16	–	–	–
	M180×3	125	3,27	AH24134	170	11	16	–	–	–
	M190×3	134	4,83	AH3234	170	6	24	–	–	–
	M190×3	134	4,83	AH3234-H	170	6	24	M6	4,5	7
	M180×3	134	4,29	AH3234G	170	6	24	–	–	–
	M180×3	134	4,29	AH3234G-H	170	6	24	M6	4,5	7
	M190×3	146	5,32	AH2334	170	6	24	–	–	–
	M190×3	146	5,32	AH2334-H	170	6	24	M6	4,5	7
	M180×3	146	4,78	AH2334G	170	6	24	–	–	–
	M180×3	146	4,78	AH2334G-H	170	6	24	M6	4,5	7
M190×3	164	6,11	AH3334	170	6	24	–	–	–	
M190×3	164	6,11	AH3334-H	170	6	24	M6	4,5	7	

medias ▶ <https://www.schaeffler.de/std/1EAC>





Withdrawal sleeves

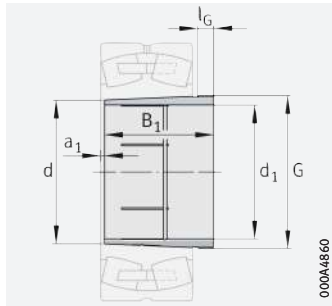

Hydraulic withdrawal sleeve
Taper 1:12
(taper 1:30 for AH240, AH241)

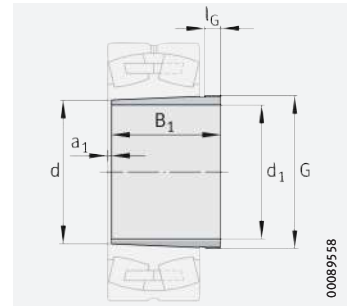

Taper 1:12
(taper 1:30 for AH240, AH241)

$d_1 = 170 - 180 \text{ mm}$

Main dimensions			Mass m ≈ kg	Designation ▶ 1698 1.4	Dimensions			Mounting dimensions		
d_1	G	B_1			d	a_1 ≈	l_G	G_1	a	l_{G1}
170	M190×3	66	1,96	AH3936	180	5	13	–	–	–
	M190×3	69	2,1	AH236	180	5	16	–	–	–
	M190×3	92	2,87	AH3036	180	6	17	–	–	–
	M190×3	92	2,87	AH3036-H	180	6	17	M6	4,2	7
	M200×3	105	3,76	AH2236	180	5	17	–	–	–
	M200×3	105	3,68	AH2236-H	180	5	17	M6	4,5	7
	M190×3	105	3,35	AH2236G	180	5	17	–	–	–
	M190×3	105	3,28	AH2236G-H	180	5	17	M6	4,5	7
	M190×3	116	3,21	AH24036	180	11	16	–	–	–
	M190×3	116	3,79	AH3136A	180	6	19	–	–	–
	M190×3	116	3,79	AH3136A-H	180	6	19	M6	4,5	7
	M190×3	134	3,74	AH24136	180	11	16	–	–	–
	M200×3	140	5,39	AH3236	180	6	25	–	–	–
	M200×3	140	5,39	AH3236-H	180	6	25	M6	4,5	7
	M190×3	140	4,8	AH3236G	180	6	25	–	–	–
	M190×3	140	4,8	AH3236G-H	180	6	25	M6	4,5	7
	M200×3	154	6,04	AH2336	180	6	26	–	–	–
	M200×3	154	6,04	AH2336-H	180	6	26	M6	4,5	7
	M190×3	154	5,42	AH2336G	180	6	26	–	–	–
	M190×3	154	5,42	AH2336G-H	180	6	26	M6	4,5	7
M200×3	176	7,1	AH3336	180	6	26	–	–	–	
M200×3	176	7,1	AH3336-H	180	6	26	M6	4,5	7	

medias ▶ <https://www.schaeffler.de/std/1EAD>

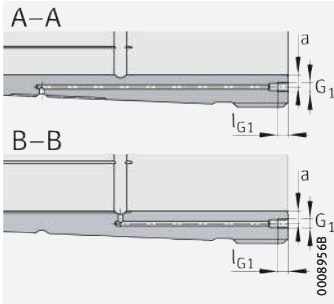

Hydraulic withdrawal sleeve
(suffix H)
Mounting dimensions

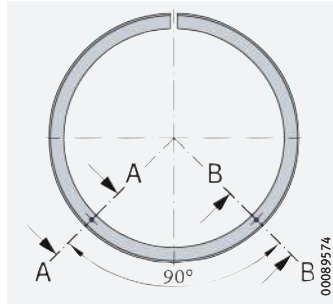

Oil connectors
for hydraulic withdrawal sleeve

Main dimensions			Mass m ≈ kg	Designation ▶ 1698 1.4	Dimensions			Mounting dimensions		
d_1	G	B_1			d	a_1 ≈	l_G	G_1	a	l_{G1}
180	M200×3	66	2,07	AH3938	190	5	13	–	–	–
	Tr205×4	73	2,57	AH238	190	5	17	–	–	–
	M200×3	73	2,36	AH238G	190	5	17	–	–	–
	Tr205×4	96	3,42	AH3038	190	6	18	–	–	–
	Tr205×4	96	3,42	AH3038-H	190	6	18	M6	4,2	7
	M200×3	96	3,19	AH3038G	190	6	18	–	–	–
	M200×3	96	3,19	AH3038G-H	190	6	18	M6	4,2	7
	Tr210×4	112	4,28	AH2238	190	5	18	–	–	–
	Tr210×4	112	4,19	AH2238-H	190	5	18	M6	4,5	7
	M200×3	112	3,83	AH2238G	190	5	18	–	–	–
	M200×3	112	3,75	AH2238G-H	190	5	18	M6	4,5	7
	M200×3	118	3,48	AH24038	190	13	18	–	–	–
	Tr210×4	125	4,89	AH3138	190	6	20	–	–	–
	Tr210×4	125	4,89	AH3138-H	190	6	20	M6	4,5	7
	M200×3	125	4,39	AH3138G	190	6	20	–	–	–
	M200×3	125	4,39	AH3138G-H	190	6	20	M6	4,5	7
	Tr210×4	145	5,92	AH3238	190	7	25	–	–	–
	Tr210×4	145	5,92	AH3238-H	190	7	25	M6	4,5	7
	M200×3	145	5,3	AH3238G	190	7	25	–	–	–
	M200×3	145	5,3	AH3238G-H	190	7	25	M6	4,5	7
	M200×3	146	4,37	AH24138	190	13	18	–	–	–
	Tr210×4	160	6,67	AH2338	190	7	26	–	–	–
	Tr210×4	160	6,67	AH2338-H	190	7	26	M6	4,5	7
	M200×3	160	6,02	AH2338G	190	7	26	–	–	–
M200×3	160	6,02	AH2338G-H	190	7	26	M6	4,5	7	
Tr210×4	181	7,76	AH3338	190	7	26	–	–	–	
Tr210×4	181	7,76	AH3338-H	190	7	26	M6	4,5	7	

medias ▶ <https://www.schaeffler.de/std/1EAE>





Withdrawal sleeves

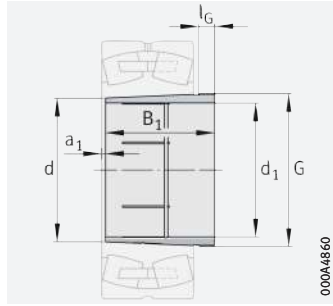

Hydraulic withdrawal sleeve
Taper 1:12
(taper 1:30 for AH240, AH241)

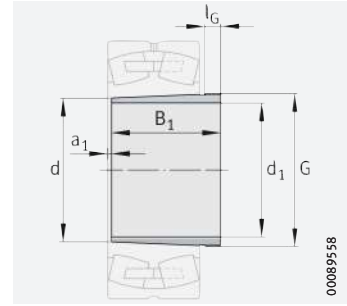

Taper 1:12
(taper 1:30 for AH240, AH241)

$d_1 = 190 - 200 \text{ mm}$

Main dimensions			Mass m ≈ kg	Designation ▶ 1698 1.4	Dimensions			Mounting dimensions		
d_1	G	B_1			d	a_1 ≈	l_G	G_1	a	l_{G1}
190	Tr215×4	77	2,88	AH240	200	5	18	–	–	–
	Tr210×4	77	2,43	AH240G	200	5	18	–	–	–
	Tr210×4	77	2,62	AH3940	200	6	16	–	–	–
	Tr215×4	102	3,86	AH3040	200	6	19	–	–	–
	Tr215×4	102	3,86	AH3040-H	200	6	19	M6	4,2	7
	Tr210×4	102	3,62	AH3040G	200	6	19	–	–	–
	Tr210×4	102	3,62	AH3040G-H	200	6	19	M6	4,2	7
	Tr220×4	118	4,8	AH2240	200	5	19	–	–	–
	Tr220×4	118	4,7	AH2240-H	200	5	19	M6	4,5	7
	Tr210×4	127	3,96	AH24040	200	13	18	–	–	–
	Tr210×4	127	3,93	AH24040-H	200	13	18	M6	8	7
	Tr220×4	134	5,6	AH3140	200	6	21	–	–	–
	Tr220×4	134	5,6	AH3140-H	200	6	21	M6	4,5	7
	Tr220×4	153	6,61	AH3240	200	7	24	–	–	–
	Tr220×4	153	6,61	AH3240-H	200	7	24	M6	4,5	7
	Tr210×4	158	5,02	AH24140	200	13	18	–	–	–
	Tr220×4	170	7,64	AH2340	200	7	30	–	–	–
	Tr220×4	170	7,64	AH2340-H	200	7	30	M6	4,5	7
Tr220×4	195	9,04	AH3340	200	7	30	–	–	–	
Tr220×4	195	9,04	AH3340-H	200	7	30	M6	4,5	7	

medias ▶ <https://www.schaeffler.de/std/1EAF>

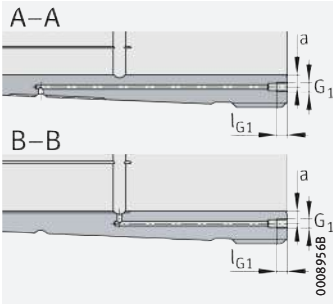

Hydraulic withdrawal sleeve
(suffix H)
Mounting dimensions

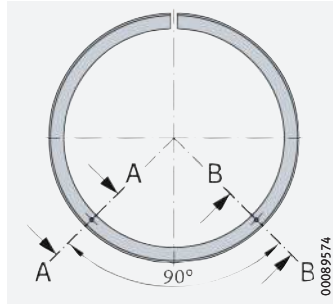

Oil connectors
for hydraulic withdrawal sleeve

Main dimensions			Mass m ≈ kg	Designation ▶ 1698 1.4	Dimensions			Mounting dimensions		
d_1	G	B_1			d	a_1 ≈	l_G	G_1	a	l_{G1}
200	Tr230×4	77	4,81	AH3944	220	6	16	–	–	–
	Tr230×4	77	4,81	AH3944-H	220	6	16	M8	7,5	12
	Tr235×4	85	5,62	AH244	220	6	18	–	–	–
	Tr230×4	85	5,36	AH244G	220	6	18	–	–	–
	Tr235×4	111	7,47	AH3044	220	6	20	–	–	–
	Tr235×4	111	7,47	AH3044-H	220	6	20	$G^{1/8}$	8,5	12
	Tr230×4	111	7,18	AH3044G	220	6	20	–	–	–
	Tr230×4	111	7,18	AH3044G-H	220	6	20	$G^{1/8}$	6,5	12
	Tr240×4	130	9,17	AH2244	220	6	20	–	–	–
	Tr240×4	130	8,99	AH2244-H	220	6	20	$G^{1/8}$	8,5	12
	Tr230×4	138	8,22	AH24044	220	14	18	–	–	–
	Tr230×4	138	8,22	AH24044-H	220	14	18	M6	8	7
	Tr240×4	145	10,4	AH3144	220	6	23	–	–	–
	Tr240×4	145	10,4	AH3144-H	220	6	23	$G^{1/8}$	8,5	12
	Tr230×4	170	10,3	AH24144	220	14	20	–	–	–
	Tr230×4	170	10,3	AH24144-H	220	14	20	M6	8	7
	Tr240×4	181	13,6	AH2344	220	8	30	–	–	–
	Tr240×4	181	13,6	AH2344-H	220	8	30	$G^{1/8}$	8,5	12
	Tr240×4	210	16,2	AH3344	220	8	30	–	–	–
	Tr240×4	210	16,2	AH3344-H	220	8	30	$G^{1/8}$	8,5	12

medias ▶ <https://www.schaeffler.de/std/1EBO>





Withdrawal sleeves

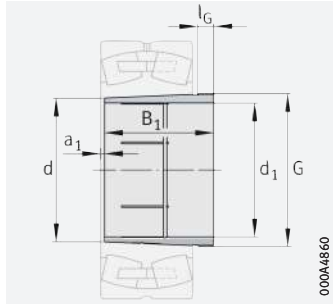

Hydraulic withdrawal sleeve
Taper 1:12
(taper 1:30 for AH240, AH241, AH248)

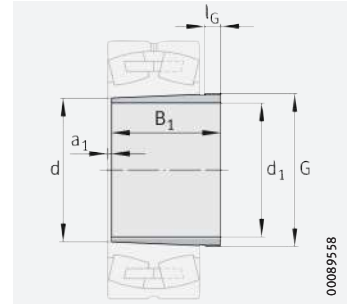

Taper 1:12
(taper 1:30 for AH240, AH241)

$d_1 = 220 - 240 \text{ mm}$

Main dimensions			Mass m ≈ kg	Designation ▶ 1698 1.4	Dimensions			Mounting dimensions		
d_1	G	B_1			d	a_1 ≈	l_G	G_1	a	l_{G1}
220	Tr250×4	77	5,26	AH3948	240	6	16	–	–	–
	Tr250×4	77	5,26	AH3948-H	240	6	16	M8	8,5	12
	Tr260×4	96	7,41	AH248	240	6	22	–	–	–
	Tr260×4	116	8,92	AH3048	240	7	21	–	–	–
	Tr260×4	116	8,92	AH3048-H	240	7	21	$G^{1/8}$	8,5	12
	Tr250×4	138	9,03	AH24048	240	15	20	–	–	–
	Tr250×4	138	9,03	AH24048-H	240	15	20	$G^{1/8}$	8,5	12
	Tr260×4	144	11,3	AH2248	240	6	21	–	–	–
	Tr260×4	144	11	AH2248-H	240	6	21	$G^{1/8}$	8,5	12
	Tr260×4	154	12,3	AH3148	240	7	25	–	–	–
	Tr260×4	154	12,3	AH3148-H	240	7	25	$G^{1/8}$	8,5	12
	Tr260×4	180	12,6	AH24148	240	15	20	–	–	–
	Tr260×4	180	12,6	AH24148-H	240	15	20	$G^{1/8}$	8,5	12
	Tr260×4	189	15,6	AH2348	240	8	30	–	–	–
	Tr260×4	189	15,6	AH2348-H	240	8	30	$G^{1/8}$	8,5	12
	Tr260×4	225	19,3	AH3348	240	8	30	–	–	–
Tr260×4	225	19,3	AH3348-H	240	8	30	$G^{1/8}$	8,5	12	

medias ▶ <https://www.schaeffler.de/std/1EB1>

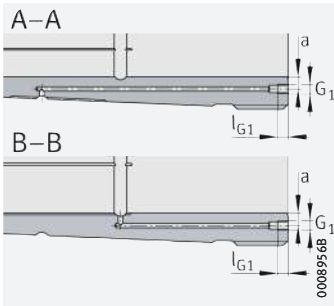

Hydraulic withdrawal sleeve
(suffix H)
Mounting dimensions

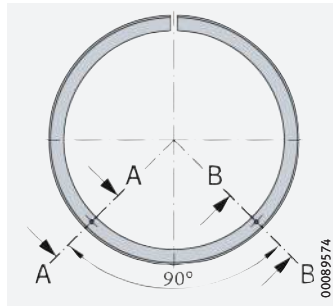

Oil connectors
for hydraulic withdrawal sleeve

Main dimensions			Mass m ≈ kg	Designation ▶ 1698 1.4	Dimensions			Mounting dimensions		
d_1	G	B_1			d	a_1 ≈	l_G	G_1	a	l_{G1}
240	Tr275×4	94	7,39	AH3952	260	6	18	–	–	–
	Tr275×4	94	7,39	AH3952-H	260	6	18	M8	8,5	12
	Tr280×4	94	7,7	AH3952G	260	6	18	–	–	–
	Tr280×4	94	7,7	AH3952G-H	260	6	18	M8	8,5	12
	Tr280×4	105	8,83	AH252	260	6	23	–	–	–
	Tr280×4	128	10,8	AH3052	260	7	23	–	–	–
	Tr280×4	128	10,8	AH3052-H	260	7	23	$G^{1/8}$	8,5	12
	Tr290×4	155	14,1	AH2252	260	6	23	–	–	–
	Tr290×4	155	13,8	AH2252-H	260	6	23	$G^{1/8}$	8,5	12
	Tr280×4	155	13,3	AH2252G	260	6	23	–	–	–
	Tr280×4	155	13,1	AH2252G-H	260	6	23	$G^{1/8}$	8,5	12
	Tr270×4	162	11,6	AH24052	260	16	20	–	–	–
	Tr270×4	162	11,6	AH24052-H	260	16	20	M6	8,5	7
	Tr280×4	162	12,3	AH24052G	260	16	20	–	–	–
	Tr280×4	162	12,3	AH24052G-H	260	16	20	M6	8,5	7
	Tr290×4	172	16	AH3152	260	7	26	–	–	–
	Tr290×4	172	16	AH3152-H	260	7	26	$G^{1/8}$	8,5	12
	Tr280×4	172	15,1	AH3152G	260	7	26	–	–	–
	Tr280×4	172	15,1	AH3152G-H	260	7	26	$G^{1/8}$	8,5	12
	Tr280×4	202	15,5	AH24152	260	16	22	–	–	–
	Tr280×4	202	15,5	AH24152-H	260	16	22	$G^{1/8}$	8,5	12
	Tr290×4	205	19,7	AH2352	260	8	30	–	–	–
	Tr290×4	205	19,7	AH2352-H	260	8	30	$G^{1/8}$	8,5	12
	Tr280×4	205	18,7	AH2352G	260	8	30	–	–	–
Tr280×4	205	18,7	AH2352G-H	260	8	30	$G^{1/8}$	8,5	12	
Tr290×4	236	23,2	AH3352	260	8	30	–	–	–	
Tr290×4	236	23,2	AH3352-H	260	8	30	$G^{1/8}$	8,5	12	

medias ▶ <https://www.schaeffler.de/std/1EB2>





Withdrawal sleeves

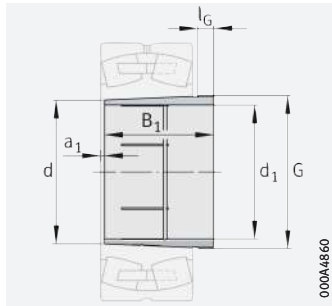

Hydraulic withdrawal sleeve
Taper 1:12
(taper 1:30 for AH240, AH241)

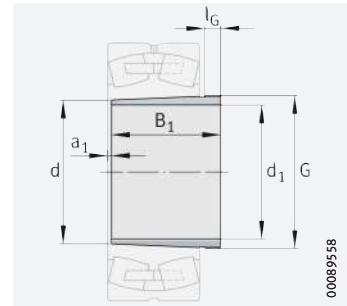

Taper 1:12
(taper 1:30 for AH240, AH241)

$d_1 = 260 - 280 \text{ mm}$

Main dimensions			Mass m ≈ kg	Designation ▶ 1698 1.4	Dimensions			Mounting dimensions		
d_1	G	B_1			d	a_1 ≈	l_G	G_1	a	l_{G1}
260	Tr295×4	94	7,98	AH3956	280	6	18	–	–	–
	Tr295×4	94	7,98	AH3956-H	280	6	18	M8	8,5	12
	Tr300×4	94	8,3	AH3956G	280	6	18	–	–	–
	Tr300×4	94	8,3	AH3956G-H	280	6	18	M8	8,5	12
	Tr300×4	105	9,52	AH256	280	8	23	–	–	–
	Tr300×4	131	12	AH3056	280	8	24	–	–	–
	Tr300×4	131	12	AH3056-H	280	8	24	$G^{1/8}$	8,5	12
	Tr310×5	155	15,3	AH2256	280	8	24	–	–	–
	Tr310×5	155	15	AH2256-H	280	8	24	$G^{1/8}$	8,5	12
	Tr300×4	155	14,4	AH2256G	280	8	24	–	–	–
	Tr300×4	155	14,1	AH2256G-H	280	8	24	$G^{1/8}$	8,5	12
	Tr290×4	162	12,6	AH24056	280	17	22	–	–	–
	Tr290×4	162	12,6	AH24056-H	280	17	22	M6	8,5	7
	Tr300×4	162	13,4	AH24056G	280	17	22	–	–	–
	Tr300×4	162	13,4	AH24056G-H	280	17	22	M6	8,5	7
	Tr310×5	175	17,7	AH3156	280	8	28	–	–	–
	Tr310×5	175	17,7	AH3156-H	280	8	28	$G^{1/8}$	8,5	12
	Tr300×4	175	16,7	AH3156G	280	8	28	–	–	–
	Tr300×4	175	16,7	AH3156G-H	280	8	28	$G^{1/8}$	8,5	12
	Tr300×4	202	16,7	AH24156	280	17	22	–	–	–
	Tr300×4	202	16,7	AH24156-H	280	17	22	$G^{1/8}$	8,5	12
	Tr310×5	212	22,1	AH2356	280	8	30	–	–	–
	Tr310×5	212	22,1	AH2356-H	280	8	30	$G^{1/8}$	8,5	12
	Tr300×4	212	20,9	AH2356G	280	8	30	–	–	–
Tr300×4	212	20,9	AH2356G-H	280	8	30	$G^{1/8}$	8,5	12	
Tr310×5	254	27,4	AH3356	280	8	30	–	–	–	
Tr310×5	254	27,4	AH3356-H	280	8	30	$G^{1/8}$	8,5	12	

medias ▶ <https://www.schaeffler.de/std/1EB3>

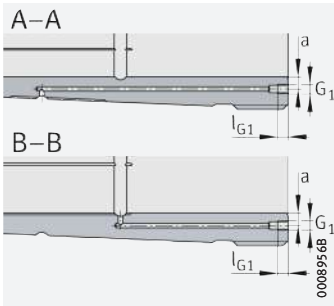

Hydraulic withdrawal sleeve
(suffix H)
Mounting dimensions

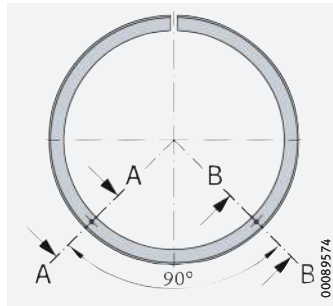

Oil connectors
for hydraulic withdrawal sleeve

Main dimensions			Mass m ≈ kg	Designation ▶ 1698 1.4	Dimensions			Mounting dimensions		
d_1	G	B_1			d	a_1 ≈	l_G	G_1	a	l_{G1}
280	Tr315×5	112	10,4	AH3960	300	7	21	–	–	–
	Tr315×5	112	10,4	AH3960-H	300	7	21	M8	8,5	12
	Tr320×5	112	10,8	AH3960G	300	7	21	–	–	–
	Tr320×5	112	10,8	AH3960G-H	300	7	21	M8	8,5	12
	Tr320×5	145	14,4	AH3060	300	8	26	–	–	–
	Tr320×5	145	14,4	AH3060-H	300	8	26	$G^{1/8}$	8,5	12
	Tr330×5	170	18,3	AH2260	300	8	26	–	–	–
	Tr330×5	170	17,9	AH2260-H	300	8	26	$G^{1/8}$	8,5	12
	Tr320×5	170	17,2	AH2260G	300	8	26	–	–	–
	Tr320×5	170	16,9	AH2260G-H	300	8	26	$G^{1/8}$	8,5	12
	Tr310×5	184	15,5	AH24060	300	18	24	–	–	–
	Tr310×5	184	15,5	AH24060-H	300	18	24	M6	8,5	7
	Tr320×5	184	16,4	AH24060G	300	18	24	–	–	–
	Tr320×5	184	16,4	AH24060G-H	300	18	24	M6	8,5	7
	Tr330×5	192	21,2	AH3160	300	8	30	–	–	–
	Tr330×5	192	21,2	AH3160-H	300	8	30	$G^{1/8}$	8,5	12
	Tr320×5	192	20	AH3160G	300	8	30	–	–	–
	Tr320×5	192	20	AH3160G-H	300	8	30	$G^{1/8}$	8,5	12
	Tr320×5	224	20,1	AH24160	300	18	24	–	–	–
	Tr320×5	224	20,1	AH24160-H	300	18	24	$G^{1/8}$	8,5	12
Tr330×5	228	26	AH3260	300	8	34	–	–	–	
Tr330×5	228	26	AH3260-H	300	8	34	$G^{1/8}$	8,5	12	
Tr320×5	228	24,6	AH3260G	300	8	34	–	–	–	
Tr320×5	228	24,6	AH3260G-H	300	8	34	$G^{1/8}$	8,5	12	
Tr330×5	270	31,8	AH3360	300	8	34	–	–	–	
Tr330×5	270	31,8	AH3360-H	300	8	34	$G^{1/8}$	8,5	12	

medias ▶ <https://www.schaeffler.de/std/1EB4>





Withdrawal sleeves

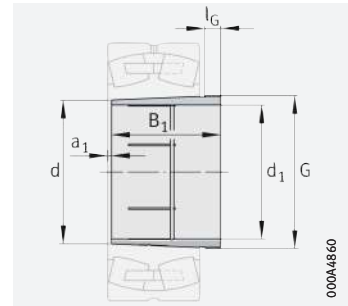

Hydraulic withdrawal sleeve
Taper 1:12
(taper 1:30 for AH240, AH241)

$d_1 = 300 - 380 \text{ mm}$

Main dimensions			Mass m ≈ kg	Designation ▶ 1698 1.4	Dimensions			Mounting dimensions		
d_1	G	B_1			d	a_1 ≈	l_G	G_1	a	l_{G1}
300	Tr335×5	112	11,1	AH3964-H	320	7	21	M8	8,5	12
	Tr340×5	112	11,5	AH3964G-H	320	7	21	M8	8,5	12
	Tr345×5	149	16,5	AH3064-H	320	8	27	G ^{1/8}	8,5	12
	Tr340×5	149	15,9	AH3064G-H	320	8	27	G ^{1/8}	8,5	12
	Tr350×5	180	20,6	AH2264-H	320	10	27	G ^{1/8}	8,5	12
	Tr340×5	180	19,6	AH2264G-H	320	10	27	G ^{1/8}	8,5	12
	Tr330×5	184	16,6	AH24064-H	320	18	24	M6	8,5	7
	Tr340×5	184	17,5	AH24064G-H	320	18	24	M6	8,5	7
	Tr350×5	209	24,9	AH3164-H	320	8	31	G ^{1/8}	8,5	12
	Tr340×5	209	23,6	AH3164G-H	320	8	31	G ^{1/8}	8,5	12
	Tr340×5	242	23,4	AH24164-H	320	18	24	G ^{1/8}	8,5	12
	Tr350×5	246	30,4	AH3264-H	320	8	36	G ^{1/8}	8,5	12
	Tr340×5	246	28,9	AH3264G-H	320	8	36	G ^{1/8}	8,5	12
	Tr350×5	294	37,9	AH3364-H	320	8	36	G ^{1/8}	8,5	12
320	Tr355×5	112	11,8	AH3968-H	340	7	21	M8	8,5	12
	Tr360×5	112	12,3	AH3968G-H	340	7	21	M8	8,5	12
	Tr365×5	162	19,2	AH3068-H	340	9	28	G ^{1/8}	8,5	12
	Tr360×5	162	18,6	AH3068G-H	340	9	28	G ^{1/8}	8,5	12
	Tr360×5	206	21,1	AH24068-H	340	19	26	G ^{1/8}	8,5	12
	Tr370×5	225	28,9	AH3168-H	340	9	33	G ^{1/8}	8,5	12
	Tr360×5	225	27,5	AH3168G-H	340	9	33	G ^{1/8}	8,5	12
	Tr370×5	264	35,3	AH3268-H	340	9	38	G ^{1/8}	8,5	12
	Tr360×5	264	33,6	AH3268G-H	340	9	38	G ^{1/8}	8,5	12
	Tr360×5	269	28	AH24168-H	340	19	26	G ^{1/8}	8,5	12
	Tr370×5	310	43,1	AH3368-H	340	9	38	G ^{1/8}	8,5	12

medias ▶ <https://www.schaeffler.de/std/1EB5>

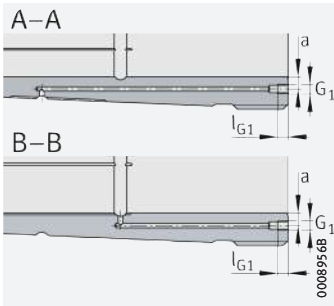

Hydraulic withdrawal sleeve
(suffix H)
Mounting dimensions

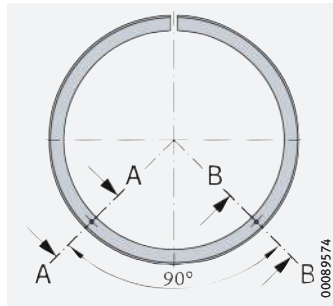

Oil connectors
for hydraulic withdrawal sleeve

Main dimensions			Mass m ≈ kg	Designation ▶ 1698 1.4	Dimensions			Mounting dimensions		
d_1	G	B_1			d	a_1 ≈	l_G	G_1	a	l_{G1}
340	Tr375×5	112	12,5	AH3972-H	360	7	21	M8	8,5	12
	Tr380×5	112	13	AH3972G-H	360	7	21	M8	8,5	12
	Tr385×5	167	21,2	AH3072-H	360	9	30	$G^{1/8}$	8,5	12
	Tr380×5	167	20,5	AH3072G-H	360	9	30	$G^{1/8}$	8,5	12
	Tr380×5	206	22,3	AH24072-H	360	20	26	$G^{1/8}$	8,5	12
	Tr400×5	229	33,1	AH3172-H	360	9	35	$G^{1/8}$	8,5	12
	Tr380×5	229	29,8	AH3172G-H	360	9	35	$G^{1/8}$	8,5	12
	Tr380×5	269	29,7	AH24172-H	360	20	26	$G^{1/8}$	8,5	12
	Tr400×5	274	41,1	AH3272-H	360	9	40	$G^{1/8}$	8,5	12
	Tr380×5	274	37,3	AH3272G-H	360	9	40	$G^{1/8}$	8,5	12
	Tr400×5	330	51,5	AH3372-H	360	9	40	$G^{1/8}$	8,5	12
360	Tr395×5	130	15,6	AH3976-H	380	8	22	M8	8,5	12
	Tr400×5	130	16,1	AH3976G-H	380	8	22	M8	8,5	12
	Tr410×5	170	23,6	AH3076-H	380	10	31	$G^{1/8}$	8,5	12
	Tr400×5	170	22,1	AH3076G-H	380	10	31	$G^{1/8}$	8,5	12
	Tr400×5	208	24	AH24076-H	380	20	28	$G^{1/8}$	8,5	12
	Tr420×5	232	35,6	AH3176-H	380	10	36	$G^{1/8}$	8,5	12
	Tr400×5	232	32	AH3176G-H	380	10	36	$G^{1/8}$	8,5	12
	Tr400×5	271	31,8	AH24176-H	380	20	28	$G^{1/8}$	8,5	12
	Tr420×5	284	45,5	AH3276-H	380	10	42	$G^{1/8}$	8,5	12
	Tr400×5	284	41,3	AH3276G-H	380	10	42	$G^{1/8}$	8,5	12
	Tr420×5	342	57,1	AH3376-H	380	10	42	$G^{1/8}$	8,5	12
380	Tr415×5	130	16,4	AH3980-H	400	8	22	M8	8,5	12
	Tr420×5	130	17	AH3980G-H	400	8	22	M8	8,5	12
	Tr430×5	183	27,1	AH3080-H	400	10	33	$G^{1/8}$	8,5	12
	Tr420×5	183	25,4	AH3080G-H	400	10	33	$G^{1/8}$	8,5	12
	Tr420×5	228	27,8	AH24080-H	400	20	28	$G^{1/8}$	8,5	12
	Tr440×5	240	39,1	AH3180-H	400	10	38	$G^{1/8}$	8,5	12
	Tr420×5	240	35,1	AH3180G-H	400	10	38	$G^{1/8}$	8,5	12
	Tr420×5	278	34,4	AH24180-H	400	20	28	$G^{1/8}$	8,5	12
	Tr440×5	302	51,7	AH3280-H	400	10	44	$G^{1/8}$	8,5	12
	Tr420×5	302	47,1	AH3280G-H	400	10	44	$G^{1/8}$	8,5	12
	Tr440×5	352	62,5	AH3380-H	400	10	44	$G^{1/8}$	8,5	12

medias ▶ <https://www.schaeffler.de/std/1EB6>





Withdrawal sleeves

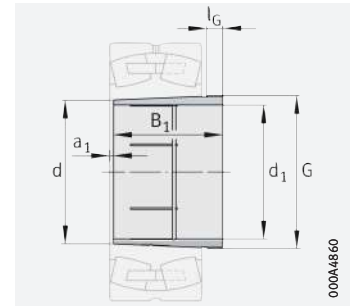

Hydraulic withdrawal sleeve
Taper 1:12
(taper 1:30 for AH240, AH241)

d₁ = 400 – 500 mm

Main dimensions			Mass m ≈ kg	Designation ▶ 1698 1.4	Dimensions			Mounting dimensions		
d ₁	G	B ₁			d	a ₁ ≈	l _G	G ₁	a	l _{G1}
400	Tr435×5	130	17,3	AH3984-H	420	8	22	M8	8,5	12
	Tr440×5	130	17,8	AH3984G-H	420	8	22	M8	8,5	12
	Tr450×5	186	29,1	AH3084-H	420	10	34	G ¹ / ₈	8,5	12
	Tr440×5	186	27,2	AH3084G-H	420	10	34	G ¹ / ₈	8,5	12
	Tr440×5	230	29,6	AH24084-H	420	22	30	G ¹ / ₈	8,5	12
	Tr460×5	266	46,4	AH3184-H	420	10	40	G ¹ / ₈	8,5	12
	Tr440×5	266	42	AH3184G-H	420	10	40	G ¹ / ₈	8,5	12
	Tr440×5	310	41	AH24184-H	420	22	30	G ¹ / ₈	8,5	12
	Tr460×5	321	58,6	AH3284-H	420	10	46	G ¹ / ₈	8,5	12
	Tr440×5	321	53,6	AH3284G-H	420	10	46	G ¹ / ₈	8,5	12
	Tr460×5	361	67,9	AH3384-H	420	10	46	G ¹ / ₈	8,5	12
420	Tr460×5	145	21,2	AH3988-H	440	8	25	G ¹ / ₈	8,5	12
	Tr470×5	194	31,9	AHX3088-H	440	11	35	G ¹ / ₈	8,5	12
	Tr460×5	194	30	AHX3088G-H	440	11	35	G ¹ / ₈	8,5	12
	Tr460×5	242	32,8	AH24088-H	440	22	30	G ¹ / ₈	8,5	12
	Tr480×5	270	49,7	AHX3188-H	440	11	42	G ¹ / ₈	8,5	12
	Tr460×5	270	44,9	AHX3188G-H	440	11	42	G ¹ / ₈	8,5	12
	Tr460×5	310	42,9	AH24188-H	440	22	30	G ¹ / ₈	8,5	12
	Tr480×5	330	63,7	AHX3288-H	440	11	48	G ¹ / ₈	8,5	12
	Tr460×5	330	58,2	AHX3288G-H	440	11	48	G ¹ / ₈	8,5	12
	Tr480×5	393	79,6	AH3388-H	440	11	48	G ¹ / ₈	8,5	12
440	Tr480×5	145	22,2	AH3992-H	460	8	25	G ¹ / ₈	8,5	12
	Tr490×5	202	35,1	AHX3092-H	460	11	37	G ¹ / ₈	8,5	12
	Tr480×5	202	32,9	AHX3092G-H	460	11	37	G ¹ / ₈	8,5	12
	Tr480×5	250	35,6	AH24092-H	460	23	32	G ¹ / ₈	8,5	12
	Tr510×6	285	58	AHX3192-H	460	11	43	G ¹ / ₈	8,5	12
	Tr480×5	285	50,3	AHX3192G-H	460	11	43	G ¹ / ₈	8,5	12
	Tr480×5	332	48,7	AH24192-H	460	23	32	G ¹ / ₈	8,5	12
	Tr510×6	349	74,6	AHX3292-H	460	11	50	G ¹ / ₈	8,5	12
	Tr480×5	349	65,6	AHX3292G-H	460	11	50	G ¹ / ₈	8,5	12
	Tr510×6	415	92,6	AH3392-H	460	11	50	G ¹ / ₈	8,5	12

medias ▶ <https://www.schaeffler.de/std/1EB7>

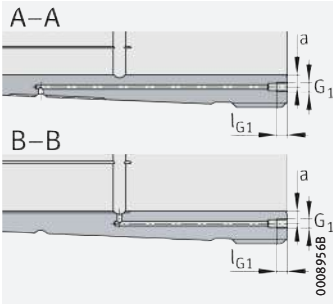

Hydraulic withdrawal sleeve
(suffix H)
Mounting dimensions

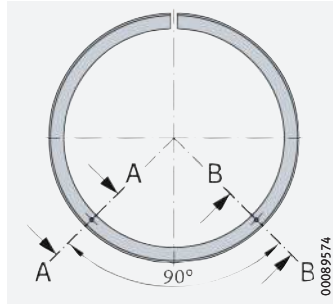

Oil connectors
for hydraulic withdrawal sleeve

Main dimensions			Mass m ≈ kg	Designation ▶ 1698 1.4	Dimensions			Mounting dimensions		
d_1	G	B_1			d	a_1 ≈	l_G	G_1	a	l_{G1}
460	Tr500×5	158	25,7	AH3996-H	480	9	28	$G^{1/8}$	8,5	12
	Tr520×6	205	39,7	AHX3096-H	480	12	38	$G^{1/8}$	8,5	12
	Tr500×5	205	35	AHX3096G-H	480	12	38	$G^{1/8}$	8,5	12
	Tr500×5	250	37,2	AH24096-H	480	23	32	$G^{1/8}$	8,5	12
	Tr530×6	295	63,3	AHX3196-H	480	12	45	$G^{1/8}$	8,5	12
	Tr500×5	295	54,8	AHX3196G-H	480	12	45	$G^{1/8}$	8,5	12
	Tr500×5	340	52,2	AH24196G-H	480	23	32	$G^{1/8}$	8,5	12
	Tr500×5	343	52,9	AH24196-H	480	25	35	$G^{1/8}$	8,5	12
	Tr530×6	364	82,2	AHX3296-H	480	12	52	$G^{1/8}$	8,5	12
	Tr500×5	364	72,4	AHX3296G-H	480	12	52	$G^{1/8}$	8,5	12
	Tr530×6	427	100	AH3396-H	480	12	52	$G^{1/8}$	8,5	12
480	Tr520×6	162	27,7	AH39/500-H	500	10	32	$G^{1/8}$	8,5	12
	Tr530×6	162	29,8	AH39/500G-H	500	10	32	$G^{1/8}$	8,5	12
	Tr540×6	209	42,5	AHX30/500-H	500	12	40	$G^{1/8}$	8,5	12
	Tr530×6	209	39,9	AHX30/500G-H	500	12	40	$G^{1/8}$	8,5	12
	Tr520×6	253	39,5	AH240/500-H	500	23	35	$G^{1/8}$	8,5	12
	Tr530×6	253	41,7	AH240/500G-H	500	23	35	$G^{1/8}$	8,5	12
	Tr550×6	313	70,9	AHX31/500-H	500	12	47	$G^{1/8}$	8,5	12
	Tr530×6	313	64,7	AHX31/500G-H	500	12	47	$G^{1/8}$	8,5	12
	Tr530×6	360	60,5	AH241/500G-H	500	23	35	$G^{1/8}$	8,5	12
	Tr520×6	362	58,8	AH241/500-H	500	25	37	$G^{1/8}$	8,5	12
	Tr550×6	393	94,4	AHX32/500-H	500	12	54	$G^{1/8}$	8,5	12
	Tr530×6	393	87,3	AHX32/500G-H	500	12	54	$G^{1/8}$	8,5	12
	Tr550×6	442	110	AH33/500-H	500	12	54	$G^{1/8}$	8,5	12
500	Tr550×6	175	43,1	AH39/530-H	530	10	37	$G^{1/4}$	10	15
	Tr560×6	175	45,6	AH39/530G-H	530	10	37	$G^{1/4}$	10	15
	Tr560×6	230	61,7	AH30/530A-H	530	12	45	$G^{1/4}$	10	15
	Tr560×6	285	67,5	AH240/530G-H	530	24	35	$G^{1/4}$	10	15
	Tr550×6	290	66,8	AH240/530-H	530	25	40	$G^{1/4}$	10	15
	Tr560×6	325	92,3	AH31/530A-H	530	12	53	$G^{1/4}$	10	15
	Tr560×6	370	89	AH241/530G-H	530	24	35	$G^{1/4}$	10	15
	Tr550×6	375	88,2	AH241/530-H	530	25	40	$G^{1/4}$	10	15
	Tr580×6	412	132	AH32/530A-H	530	12	57	$G^{1/4}$	10	15
	Tr560×6	412	124	AH32/530AG-H	530	12	57	$G^{1/4}$	10	15
	Tr580×6	469	155	AH33/530-H	530	12	57	$G^{1/4}$	10	15

medias ▶ <https://www.schaeffler.de/std/1EB8>





Withdrawal sleeves

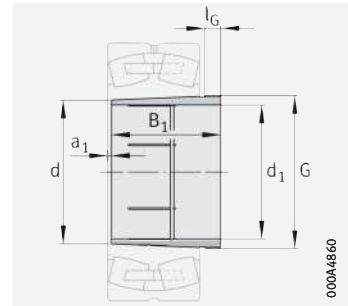

Hydraulic withdrawal sleeve
Taper 1:12
(taper 1:30 for AH240, AH241)

$d_1 = 530 - 670 \text{ mm}$

Main dimensions			Mass m ≈ kg	Designation ▶ 1698 1.4	Dimensions			Mounting dimensions		
d_1	G	B_1			d	a_1 ≈	l_G	G_1	a	l_{G1}
530	Tr580×6	180	47	AH39/560-H	560	10	37	$G^{1/4}$	12	15
	Tr600×6	180	52,3	AH39/560G-H	560	10	37	$G^{1/4}$	12	15
	Tr590×6	240	68,4	AH30/560A-H	560	12	45	$G^{1/4}$	12	15
	Tr600×6	240	71,6	AH30/560AG-H	560	12	45	$G^{1/4}$	12	15
	Tr600×6	296	77,5	AH240/560G-H	560	24	38	$G^{1/4}$	12	15
	Tr580×6	298	72,7	AH240/560-H	560	25	40	$G^{1/4}$	12	15
	Tr590×6	335	101	AH31/560A-H	560	12	55	$G^{1/4}$	12	15
	Tr600×6	335	105	AH31/560AG-H	560	12	55	$G^{1/4}$	12	15
	Tr600×6	393	104	AH241/560G-H	560	24	38	$G^{1/4}$	12	15
	Tr580×6	400	101	AH241/560-H	560	28	45	$G^{1/4}$	12	15
	Tr610×6	422	144	AH32/560A-H	560	12	57	$G^{1/4}$	12	15
	Tr600×6	422	139	AH32/560AG-H	560	12	57	$G^{1/4}$	12	15
	Tr610×6	475	166	AH33/560-H	560	12	57	$G^{1/4}$	12	15
570	Tr625×6	192	55,6	AH39/600-H	600	10	38	$G^{1/4}$	12	15
	Tr630×6	192	57	AH39/600G-H	600	10	38	$G^{1/4}$	12	15
	Tr630×6	245	75	AH30/600A-H	600	14	45	$G^{1/4}$	12	15
	Tr630×6	310	84,1	AH240/600G-H	600	26	38	$G^{1/4}$	12	15
	Tr625×6	317	85,4	AH240/600-H	600	30	45	$G^{1/4}$	12	15
	Tr630×6	355	116	AH31/600A-H	600	14	55	$G^{1/4}$	12	15
	Tr630×6	413	114	AH241/600G-H	600	26	38	$G^{1/4}$	12	15
	Tr625×6	425	118	AH241/600-H	600	30	50	$G^{1/4}$	12	15
	Tr650×6	445	164	AH32/600A-H	600	14	57	$G^{1/4}$	12	15
	Tr630×6	445	155	AH32/600AG-H	600	14	57	$G^{1/4}$	12	15
	Tr650×6	519	200	AH33/600-H	600	14	57	$G^{1/4}$	12	15

medias ▶ <https://www.schaeffler.de/std/1EB9>

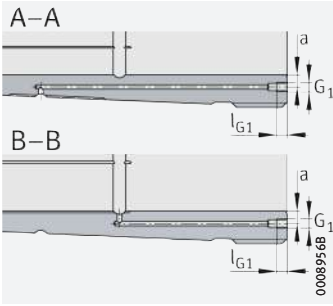

Hydraulic withdrawal sleeve
(suffix H)
Mounting dimensions

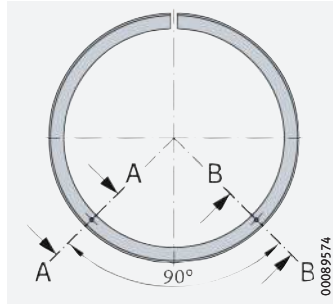

Oil connectors
for hydraulic withdrawal sleeve

Main dimensions			Mass m ≈ kg	Designation ▶ 1698 1.4	Dimensions			Mounting dimensions		
d_1	G	B_1			d	a_1 ≈	l_G	$G_{1/4}$	a	l_{G1}
600	Tr655×6	210	64,5	AH39/630-H	630	12	40	$G_{1/4}$	12	15
	Tr670×6	210	69,4	AH39/630G-H	630	12	40	$G_{1/4}$	12	15
	Tr670×6	258	87,3	AH30/630A-H	630	14	46	$G_{1/4}$	12	15
	Tr670×6	330	97,9	AH240/630G-H	630	26	40	$G_{1/4}$	12	15
	Tr655×6	335	95,1	AH240/630-H	630	30	45	$G_{1/4}$	12	15
	Tr670×6	375	136	AH31/630A-H	630	14	60	$G_{1/4}$	12	15
	Tr670×6	440	133	AH241/630G-H	630	26	40	$G_{1/4}$	12	15
	Tr655×6	450	132	AH241/630-H	630	30	50	$G_{1/4}$	12	15
	Tr680×6	475	188	AH32/630A-H	630	14	63	$G_{1/4}$	12	15
	Tr670×6	475	183	AH32/630AG-H	630	14	63	$G_{1/4}$	12	15
Tr680×6	550	227	AH33/630-H	630	14	62	$G_{1/4}$	12	15	
630	Tr695×6	216	87,7	AH39/670-H	670	12	41	$G_{1/4}$	12	15
	Tr710×7	216	92,9	AH39/670G-H	670	12	41	$G_{1/4}$	12	15
	Tr710×7	280	124	AH30/670A-H	670	14	50	$G_{1/4}$	12	15
	Tr710×7	348	137	AH240/670G-H	670	26	40	$G_{1/4}$	12	15
	Tr695×6	358	137	AH240/670-H	670	30	50	$G_{1/4}$	12	15
	Tr710×7	395	185	AH31/670A-H	670	14	60	$G_{1/4}$	12	15
	Tr710×7	452	180	AH241/670G-H	670	26	40	$G_{1/4}$	12	15
	Tr695×6	467	183	AH241/670-H	670	30	55	$G_{1/4}$	12	15
	Tr720×7	500	252	AH32/670A-H	670	14	63	$G_{1/4}$	12	15
	Tr710×7	500	247	AH32/670AG-H	670	14	63	$G_{1/4}$	12	15
Tr720×7	577	303	AH33/670-H	670	14	62	$G_{1/4}$	12	15	
670	Tr740×7	228	101	AH39/710-H	710	12	43	$G_{1/4}$	15	15
	Tr750×7	228	105	AH39/710G-H	710	12	43	$G_{1/4}$	15	15
	Tr750×7	286	135	AH30/710A-H	710	16	50	$G_{1/4}$	15	15
	Tr750×7	360	152	AH240/710G-H	710	26	45	$G_{1/4}$	15	15
	Tr740×7	365	151	AH240/710-H	710	33	50	$G_{1/4}$	15	15
	Tr750×7	405	202	AH31/710A-H	710	16	60	$G_{1/4}$	15	15
	Tr750×7	483	207	AH241/710G-H	710	26	45	$G_{1/4}$	15	15
	Tr740×7	493	209	AH241/710-H	710	33	55	$G_{1/4}$	15	15
	Tr760×7	515	278	AH32/710A-H	710	16	65	$G_{1/4}$	15	15
	Tr750×7	515	272	AH32/710AG-H	710	16	65	$G_{1/4}$	15	15
Tr760×7	595	334	AH33/710-H	710	16	65	$G_{1/4}$	15	15	

medias ▶ <https://www.schaeffler.de/std/1EBA>



Withdrawal sleeves

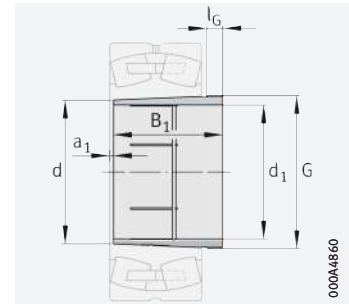

Hydraulic withdrawal sleeve
Taper 1:12
(taper 1:30 for AH240, AH241)

$d_1 = 710 - 1\ 000\ \text{mm}$

Main dimensions			Mass m ≈ kg	Designation ▶ 1698 1.4	Dimensions			Mounting dimensions		
d_1	G	B_1			d	a_1 ≈	l_G	G_1	a	l_{G1}
710	Tr780×7	234	110	AH39/750-H	750	12	44	$G^{1/4}$	15	15
	Tr800×7	234	118	AH39/750G-H	750	12	44	$G^{1/4}$	15	15
	Tr800×7	300	155	AH30/750A-H	750	16	50	$G^{1/4}$	15	15
	Tr800×7	380	174	AH240/750G-H	750	28	45	$G^{1/4}$	15	15
	Tr780×7	385	169	AH240/750-H	750	35	50	$G^{1/4}$	15	15
	Tr800×7	425	232	AH31/750A-H	750	16	60	$G^{1/4}$	15	15
	Tr800×7	520	241	AH241/750G-H	750	28	45	$G^{1/4}$	15	15
	Tr780×7	530	239	AH241/750-H	750	35	55	$G^{1/4}$	15	15
	Tr800×7	540	312	AH32/750A-H	750	16	65	$G^{1/4}$	15	15
	Tr800×7	625	377	AH33/750-H	750	16	65	$G^{1/4}$	15	15
750	Tr830×7	245	146	AH39/800-H	800	12	45	$G^{1/4}$	15	15
	Tr850×7	245	155	AH39/800G-H	800	12	45	$G^{1/4}$	15	15
	Tr850×7	308	198	AH30/800A-H	800	18	50	$G^{1/4}$	15	15
	Tr830×7	395	221	AH240/800-H	800	40	50	$G^{1/4}$	15	15
	Tr850×7	395	232	AH240/800G-H	800	28	50	$G^{1/4}$	15	15
	Tr850×7	438	297	AH31/800A-H	800	18	63	$G^{1/4}$	15	15
	Tr850×7	525	311	AH241/800G-H	800	28	50	$G^{1/4}$	15	15
	Tr830×7	530	304	AH241/800-H	800	40	55	$G^{1/4}$	15	15
	Tr850×7	550	391	AH32/800AG-H	800	18	62	$G^{1/4}$	15	15
	Tr850×7	555	396	AH32/800A-H	800	18	67	$G^{1/4}$	15	15
800	Tr880×7	258	165	AH39/850-H	850	12	50	$G^{1/4}$	15	15
	Tr900×7	258	176	AH39/850G-H	850	12	50	$G^{1/4}$	15	15
	Tr900×7	325	224	AH30/850A-H	850	18	53	$G^{1/4}$	15	15
	Tr900×7	415	259	AH240/850G-H	850	30	50	$G^{1/4}$	15	15
	Tr880×7	418	250	AH240/850-H	850	40	53	$G^{1/4}$	15	15
	Tr900×7	462	336	AH31/850A-H	850	18	63	$G^{1/4}$	15	15
	Tr880×7	560	345	AH241/850-H	850	40	60	$G^{1/4}$	15	15
	Tr900×7	560	358	AH241/850G-H	850	40	60	$G^{1/4}$	15	15
	Tr900×7	585	450	AH32/850A-H	850	18	70	$G^{1/4}$	15	15
	Tr900×7	700	567	AH33/850-H	850	18	70	$G^{1/4}$	15	15

medias ▶ <https://www.schaeffler.de/std/1EBB>

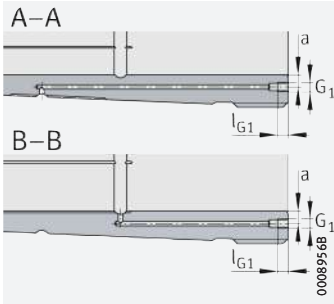

Hydraulic withdrawal sleeve
(suffix H)
Mounting dimensions

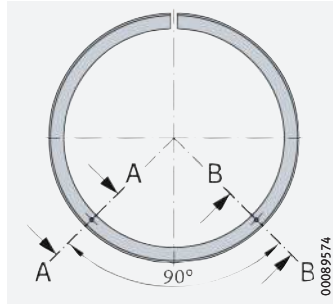

Oil connectors
for hydraulic withdrawal sleeve

Main dimensions			Mass m ≈ kg	Designation ▶ 1698 1.4	Dimensions			Mounting dimensions		
d_1	G	B_1			d	a_1 ≈	l_G	G_1	a	l_{G1}
850	Tr930×8	265	180	AH39/900-H	900	12	51	$G^{1/4}$	15	15
	Tr950×8	265	192	AH39/900G-H	900	12	51	$G^{1/4}$	15	15
	Tr950×8	335	246	AH30/900A-H	900	20	55	$G^{1/4}$	15	15
	Tr930×8	430	274	AH240/900-H	900	45	55	$G^{1/4}$	15	15
	Tr950×8	430	287	AH240/900G-H	900	45	55	$G^{1/4}$	15	15
	Tr950×8	475	368	AH31/900A-H	900	20	63	$G^{1/4}$	15	15
	Tr930×8	575	376	AH241/900-H	900	45	60	$G^{1/4}$	15	15
	Tr950×8	575	390	AH241/900G-H	900	45	60	$G^{1/4}$	15	15
	Tr950×8	585	476	AH32/900A-H	900	20	70	$G^{1/4}$	15	15
	Tr950×8	720	623	AH33/900-H	900	20	70	$G^{1/4}$	15	15
900	Tr980×8	282	203	AH39/950-H	950	15	51	$G^{1/4}$	15	15
	Tr1000×8	282	216	AH39/950G-H	950	15	51	$G^{1/4}$	15	15
	Tr1000×8	355	277	AH30/950A-H	950	20	55	$G^{1/4}$	15	15
	Tr980×8	467	316	AH240/950-H	950	45	55	$G^{1/4}$	15	15
	Tr1000×8	467	329	AH240/950G-H	950	45	55	$G^{1/4}$	15	15
	Tr1000×8	500	414	AH31/950A-H	950	20	63	$G^{1/4}$	15	15
	Tr1000×8	600	519	AH32/950A-H	950	20	70	$G^{1/4}$	15	15
	Tr980×8	605	421	AH241/950-H	950	45	60	$G^{1/4}$	15	15
	Tr1000×8	605	435	AH241/950G-H	950	45	60	$G^{1/4}$	15	15
	Tr1000×8	740	683	AH33/950-H	950	20	70	$G^{1/4}$	15	15
950	Tr1035×8	296	229	AH39/1000-H	1000	15	52	$G^{1/4}$	15	15
	Tr1060×8	296	246	AH39/1000G-H	1000	15	52	$G^{1/4}$	15	15
	Tr1060×8	365	309	AH30/1000A-H	1000	22	57	$G^{1/4}$	15	15
	Tr1035×8	469	339	AH240/1000-H	1000	50	57	$G^{1/4}$	15	15
	Tr1060×8	469	357	AH240/1000G-H	1000	50	57	$G^{1/4}$	15	15
	Tr1060×8	525	471	AH31/1000A-H	1000	22	63	$G^{1/4}$	15	15
	Tr1060×8	630	591	AH32/1000A-H	1000	22	70	$G^{1/4}$	15	15
	Tr1060×8	645	502	AH241/1000-H	1000	50	65	$G^{1/4}$	15	15
	Tr1060×8	780	781	AH33/1000-H	1000	22	70	$G^{1/4}$	15	15
1000	Tr1095×8	310	294	AH39/1060-H	1060	15	52	$G^{1/4}$	15	15
	Tr1120×8	310	312	AH39/1060G-H	1060	15	52	$G^{1/4}$	15	15
	Tr1120×8	385	396	AH30/1060A-H	1060	22	60	$G^{1/4}$	15	15
	Tr1095×8	498	445	AH240/1060-H	1060	50	60	$G^{1/4}$	15	15
	Tr1120×8	498	465	AH240/1060G-H	1060	50	60	$G^{1/4}$	15	15
	Tr1120×8	540	583	AH31/1060A-H	1060	22	65	$G^{1/4}$	15	15
	Tr1120×8	665	632	AH241/1060-H	1060	50	65	$G^{1/4}$	15	15

medias ▶ <https://www.schaeffler.de/std/1EBC>





Withdrawal sleeves

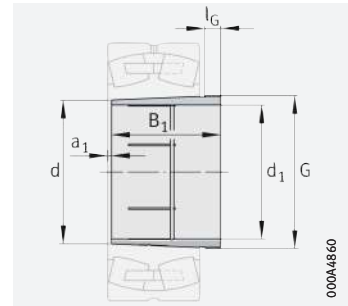

Hydraulic withdrawal sleeve
Taper 1:12
(taper 1:30 for AH240, AH241)

d₁ = 1 060 – 1 450 mm

Main dimensions			Mass m ≈ kg	Designation ▶ 1698 1.4	Dimensions			Mounting dimensions		
d ₁	G	B ₁			d	a ₁ ≈	l _G	G ₁	a	l _{G1}
1 060	Tr1180×8	410	451	AH30/1120A-H	1 120	22	65	G ^{1/4}	15	15
	Tr1155×8	527	501	AH240/1120-H	1 120	50	65	G ^{1/4}	15	15
	Tr1180×8	527	524	AH240/1120G-H	1 120	50	65	G ^{1/4}	15	15
	Tr1180×8	705	717	AH241/1120-H	1 120	50	75	G ^{1/4}	15	15
1 070	Tr1155×8	310	271	AH39/1120-H	1 120	15	52	G ^{1/4}	15	15
	Tr1180×8	310	289	AH39/1120G-H	1 120	15	52	G ^{1/4}	15	15
1 120	Tr1250×8	420	498	AH30/1180A-H	1 180	22	65	G ^{1/4}	15	15
	Tr1215×8	540	543	AH240/1180-H	1 180	50	65	G ^{1/4}	15	15
	Tr1250×8	540	577	AH240/1180G-H	1 180	50	65	G ^{1/4}	15	15
	Tr1250×8	750	824	AH241/1180-H	1 180	50	80	G ^{1/4}	15	15
1 130	Tr1215×8	330	307	AH39/1180-H	1 180	15	55	G ^{1/4}	15	15
	Tr1250×8	330	336	AH39/1180G-H	1 180	15	55	G ^{1/4}	15	15
1 180	Tr1320×8	445	629	AH30/1250A-H	1 250	22	70	G ^{1/4}	15	15
	Tr1285×8	570	694	AH240/1250-H	1 250	50	70	G ^{1/4}	15	15
	Tr1320×8	570	733	AH240/1250G-H	1 250	50	70	G ^{1/4}	15	15
	Tr1320×8	795	1 050	AH241/1250-H	1 250	50	85	G ^{1/4}	15	15
1 200	Tr1285×8	340	336	AH39/1250-H	1 250	18	55	G ^{1/4}	15	15
	Tr1320×8	340	367	AH39/1250G-H	1 250	18	55	G ^{1/4}	15	15

medias ▶ <https://www.schaeffler.de/std/1EBD>

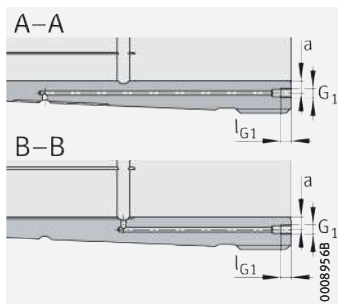

Hydraulic withdrawal sleeve
(suffix H)
Mounting dimensions

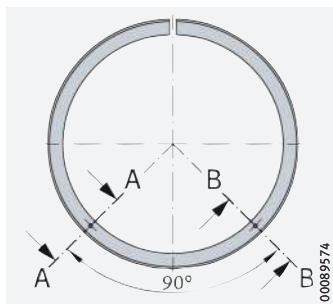

Oil connectors
for hydraulic withdrawal sleeve

Main dimensions			Mass m ≈ kg	Designation ▶ 1698 1.4	Dimensions			Mounting dimensions		
d_1	G	B_1			d	a_1 ≈	l_G	$G_{1/4}$	a	l_{G1}
1 250	Tr1400×8	470	718	AH30/1320A-H	1 320	22	70	$G_{1/4}$	15	15
	Tr1355×8	600	775	AH240/1320-H	1 320	50	70	$G_{1/4}$	15	15
	Tr1400×8	600	828	AH240/1320G-H	1 320	50	70	$G_{1/4}$	15	15
	Tr1400×8	840	1 190	AH241/1320-H	1 320	50	90	$G_{1/4}$	15	15
1 270	Tr1355×8	360	379	AH39/1320-H	1 320	18	55	$G_{1/4}$	15	15
	Tr1400×8	360	421	AH39/1320G-H	1 320	18	55	$G_{1/4}$	15	15
1 320	Tr1500×8	487	902	AH30/1400A-H	1 400	22	75	$G_{1/4}$	15	15
	Tr1435×8	615	944	AH240/1400-H	1 400	50	70	$G_{1/4}$	15	15
	Tr1500×8	615	1 030	AH240/1400G-H	1 400	50	70	$G_{1/4}$	15	15
	Tr1500×8	870	1 500	AH241/1400-H	1 400	50	95	$G_{1/4}$	15	15
1 350	Tr1435×8	380	429	AH39/1400-H	1 400	20	60	$G_{1/4}$	15	15
	Tr1500×8	380	499	AH39/1400G-H	1 400	20	60	$G_{1/4}$	15	15
1 400	Tr1600×8	537	1 260	AH30/1500A-H	1 500	22	75	$G_{1/4}$	15	15
	Tr1600×8	895	1 960	AH241/1500-H	1 500	50	95	$G_{1/4}$	15	15
1 450	Tr1540×8	400	494	AH39/1500-H	1 500	20	60	$G_{1/4}$	15	15
	Tr1600×8	400	563	AH39/1500G-H	1 500	20	60	$G_{1/4}$	15	15

medias ▶ <https://www.schaeffler.de/std/1EBE>





Locknuts

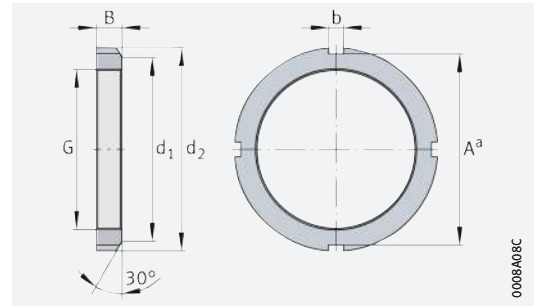

KM0 to KM20

0008A08C

G = M10×0,75 – Tr340×5

Main dimensions			Axial load carrying capacity Static F kN	Mass m ≈ kg	Designation ▶ 1698 1.4		Mounting dimensions			
G	d ₂	B			Nut	Suitable retainer	d ₁	b	A ^a	h
M10×0,75	18	4	6 000	0,005	KM0	MB0	13,5	3	14	–
M12×1	22	4	6 000	0,007	KM1	MB1	17	3	18	–
M15×1	25	5	10 000	0,01	KM2	MB2	21	4	21	–
M17×1	28	5	19 000	0,02	KM3	MB3	24	4	24	–
M20×1	32	6	12 000	0,019	KM4	MB4	26	4	28	–
M25×1,5	38	7	24 000	0,025	KM5	MB5	32	5	34	–
M30×1,5	45	7	29 000	0,043	KM6	MB6	38	5	41	–
M35×1,5	52	8	43 000	0,07	KM7	MB7	44	5	48	–
M40×1,5	58	9	58 000	0,085	KM8	MB8	50	6	53	–
M45×1,5	65	10	77 000	0,119	KM9	MB9	56	6	60	–
M50×1,5	70	11	93 000	0,148	KM10	MB10	61	6	65	–
M55×2	75	11	87 000	0,158	KM11	MB11	67	7	69	–
M60×2	80	11	90 000	0,18	KM12	MB12	73	7	74	–
M65×2	85	12	108 000	0,22	KM13	MB13	79	7	79	–
M70×2	92	12	118 000	0,26	KM14	MB14	85	8	85	–
M75×2	98	13	140 000	0,3	KM15	MB15	90	8	91	–
M80×2	105	15	190 000	0,4	KM16	MB16	95	8	98	–
M85×2	110	16	210 000	0,46	KM17	MB17	102	8	103	–
M90×2	120	16	240 000	0,6	KM18	MB18	108	10	112	–
M95×2	125	17	270 000	0,658	KM19	MB19	113	10	117	–
M100×2	130	18	290 000	0,73	KM20	MB20	120	10	122	–
M105×2	140	18	320 000	0,87	KM21	MB21	126	12	–	5
M110×2	145	19	350 000	0,965	KM22	MB22	133	12	–	5
M120×2	145	20	330 000	0,79	KML24	MBL24	135	12	–	5
M115×2	150	19	360 000	1,01	KM23	MB23	137	12	–	5
M120×2	155	20	400 000	1,08	KM24	MB24	138	12	–	5
M125×2	160	21	430 000	1,22	KM25	MB25	148	12	–	5
M130×2	155	21	370 000	0,9	KML26	MBL26	145	12	–	5
	165	21	440 000	1,24	KM26	MB26	149	12	–	5
M135×2	175	22	500 000	1,55	KM27	MB27	160	14	–	6
M140×2	165	22	410 000	1,01	KML28	MBL28	155	12	–	5
	180	22	510 000	1,56	KM28	MB28	160	14	–	6
M145×2	190	24	610 000	2,05	KM29	MB29	171	14	–	6

medias ▶ <https://www.schaeffler.de/std/1EBF>

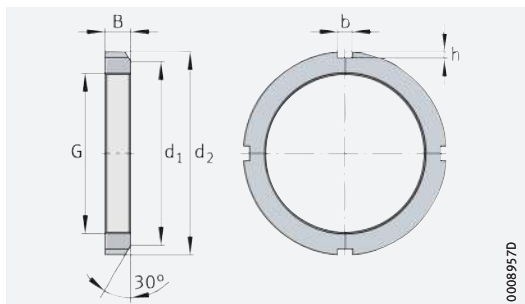

KM21 to KM40, KML, HM..T

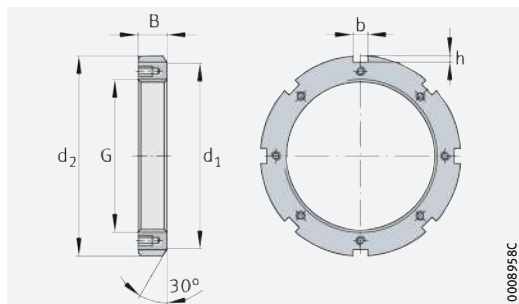

HM30, HM31

Main dimensions			Axial load carrying capacity Static F kN	Mass m ≈ kg	Designation ▶ 1698 1.4		Mounting dimensions		
G	d ₂	B			Nut	Suitable retainer	d ₁	b	h
M150×2	180	24	510 000	1,44	KML30	MBL30	170	14	5
	195	24	620 000	2,06	KM30	MB30	171	14	6
M155×3	200	25	630 000	2,27	KM31	MB31	182	16	7
M160×3	190	25	520 000	1,62	KML32	MBL32	180	14	5
	210	25	670 000	2,52	KM32	MB32	182	16	7
M165×3	210	26	680 000	2,7	KM33	MB33	193	16	7
M170×3	200	26	560 000	1,72	KML34	MBL34	190	16	5
	220	26	730 000	2,8	KM34	MB34	193	16	7
M180×3	210	27	610 000	1,96	KML36	MBL36	200	16	5
	230	27	780 000	3,04	KM36	MB36	203	18	8
M190×3	220	28	650 000	2,13	KML38	MBL38	210	16	5
	240	28	830 000	3,34	KM38	MB38	214	18	8
M200×3	240	29	800 000	2,9	KML40	MBL40	220	18	8
	250	29	900 000	3,69	KM40	MB40	226	18	8
Tr220×4	260	30	1 800 000	3,21	HM3044	MS3044	242	20	9
	280	32	2 000 000	5,3	HM44T	MB44	250	20	10
	280	32	2 300 000	4,93	HM3144	MS3144	250	20	10
Tr240×4	290	34	2 400 000	5,12	HM3048	MS3048	270	20	10
	300	34	2 400 000	6,15	HM48T	MB48	270	20	10
	300	34	2 700 000	5,75	HM3148	MS3144	270	20	10
Tr260×4	310	34	2 600 000	5,54	HM3052	MS3048	290	20	10
	330	35	2 700 000	8,05	HM52T	MB52	300	24	12
	330	36	2 900 000	7,43	HM3152	MS3152	300	24	12
Tr280×4	330	38	3 100 000	6,61	HM3056	MS3056	310	24	10
	350	36	3 000 000	8,9	HM56T	MB56	320	24	12
	350	38	3 300 000	8,26	HM3156	MS3152	320	24	12
Tr300×4	360	42	4 000 000	9,48	HM3060	MS3060	336	24	12
	380	40	3 700 000	11,4	HM3160	MS3160	340	24	12
Tr320×5	380	42	3 400 000	10,1	HM3064	MS3064	356	24	12
	400	42	3 400 000	12,8	HM3164	MS3164	360	24	12
Tr340×5	400	45	4 000 000	11,5	HM3068	MS3064	376	24	12
	440	55	5 300 000	23	HM3168	MS3168	400	28	15

medias ▶ <https://www.schaeffler.de/std/1ECO>





Locknuts

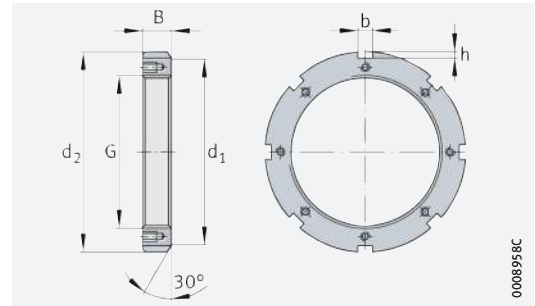

HM30, HM31

0008958C

G = Tr360×5 – Tr1600×8

Main dimensions			Axial load carrying capacity Static F kN	Mass m ≈ kg	Designation ▶ 1698 1.4		Mounting dimensions		
G	d ₂	B			Nut	Suitable retainer	d ₁	b	h
Tr360×5	420	45	4 000	11,9	HM3072	MS3072	394	28	13
	460	58	6 000	25,7	HM3172	MS3168	420	28	15
Tr380×5	450	48	4 900	15,9	HM3076	MS3076	422	28	14
	490	60	6 500	30	HM3176	MS3176	440	32	18
Tr400×5	470	52	5 600	18,2	HM3080	MS3076	442	28	14
	520	62	7 200	35,7	HM3180	MS3180	460	32	18
Tr420×5	490	52	5 700	18,9	HM3084	MS3084	462	32	14
	540	70	8 800	43,4	HM3184	MS3180	490	32	18
Tr440×5	520	60	7 600	26,5	HM3088	MS3088	490	32	15
	560	70	9 200	44,3	HM3188	MS3188	510	36	20
Tr460×5	540	60	7 800	27,7	HM3092	MS3088	510	32	15
	580	75	10 500	53,8	HM3192	MS3188	540	36	20
Tr480×5	560	60	8 000	28,7	HM3096	MS3096	530	36	15
	620	75	10 800	62,2	HM3196	MS3196	560	36	20
Tr500×5	580	68	9 500	34	HM30/500	MS3096	550	36	15
	630	80	12 300	62,1	HM31/500	MS31/500	580	40	23
Tr530×6	630	68	10 200	44,7	HM30/530	MS30/530	590	40	20
	670	80	12 400	71,2	HM31/530	MS31/530	610	40	23
Tr560×6	650	75	11 300	46,2	HM30/560	MS30/560	610	40	20
	710	85	14 000	85,6	HM31/560	MS31/560	650	45	25
Tr600×6	700	75	12 400	55,9	HM30/600	MS30/530	660	40	20
	750	85	15 000	91,7	HM31/600	MS31/560	690	45	25
Tr630×6	730	75	12 700	58,3	HM30/630	MS30/630	690	45	20
	800	95	17 800	122	HM31/630	MS31/630	730	50	28
Tr670×6	780	80	15 000	73,8	HM30/670	MS30/670	740	45	20
	850	106	21 500	156	HM31/670	MS31/670	775	50	28
Tr710×7	830	90	17 800	94,8	HM30/710	MS30/710	780	50	25
	900	106	22 200	173	HM31/710	MS31/710	825	55	30
Tr750×7	870	90	18 200	99,5	HM30/750	MS30/750	820	55	25
	950	112	25 000	202	HM31/750	MS31/750	875	60	34
Tr800×7	920	90	19 000	106	HM30/800	MS30/750	870	55	25
	1 000	112	26 300	215	HM31/800	MS31/750	925	60	34

medias ▶ <https://www.schaeffler.de/std/1EC1>



Main dimensions			Axial load carrying capacity Static	Mass	Designation ▶ 1698 1.4		Mounting dimensions			
G	d ₂	B			F	m	Nut	Suitable retainer	d ₁	b
			kN	≈ kg						
Tr850×7	980	90	20 200	113	HM30/850	MS30/850	925	60	25	
	1 060	118	29 600	246	HM31/850	MS31/850	975	70	38	
Tr900×7	1 030	100	24 000	135	HM30/900	MS30/850	975	60	25	
	1 120	125	33 500	293	HM31/900	MS31/900	1 030	70	38	
Tr950×8	1 080	100	24 000	143	HM30/950	MS30/950	1 025	60	25	
	1 170	125	34 500	310	HM31/950	MS31/950	1 080	70	38	
Tr1000×8	1 140	100	25 500	165	HM30/1000	MS30/1000	1 085	60	25	
	1 240	125	36 000	361	HM31/1000	MS31/1000	1 140	70	38	
Tr1060×8	1 200	100	25 600	175	HM30/1060	MS30/1000	1 145	60	25	
	1 300	125	38 000	386	HM31/1060	MS31/1000	1 210	70	38	
Tr1120×8	1 260	100	27 000	185	HM30/1120	MS30/1000	1 205	60	25	
	1 360	125	40 000	427	HM31/1120	MS31/1000	1 270	70	38	
Tr1180×8	1 320	100	28 000	196	HM30/1180	MS30/1000	1 265	60	25	
	1 420	125	42 000	459	HM31/1180	MS31/1000	1 330	70	38	
Tr1250×8	1 390	110	33 000	233	HM30/1250	MS30/1000	1 335	60	25	
	1 490	125	45 000	485	HM31/1250	MS31/1000	1 400	70	38	
Tr1320×8	1 460	110	34 000	245	HM30/1320	MS30/1000	1 405	60	25	
	1 560	125	47 000	511	HM31/1320	MS31/1000	1 470	70	38	
Tr1400×8	1 540	110	35 000	259	HM30/1400	MS30/1000	1 485	60	25	
	1 640	130	51 500	562	HM31/1400	MS31/1000	1 550	70	38	
Tr1500×8	1 650	110	37 000	297	HM30/1500	MS30/1500	1 595	60	25	
	1 740	130	53 000	601	HM31/1500	MS31/1000	1 650	70	38	
Tr1600×8	1 730	100	33 000	273	Z-195077.01.HM	MS30/850	1 675	60	25	

medias ▶ <https://www.schaeffler.de/std/1EC2>





Shaft nuts

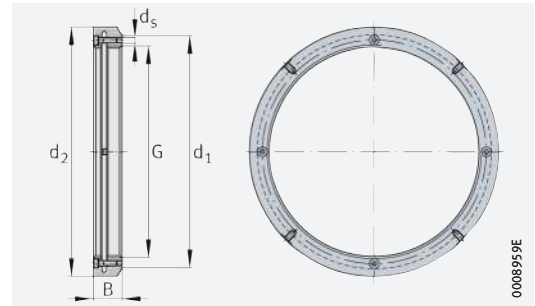

HMZ, HMZ30

0008959E

G = M90×2 – Tr1500×8

Main dimensions			Mass m ≈ kg	Designation	Dimensions		Clamping screw Quantity	Maximum tightening torque per clamping screw M _{aL} Nm
G	d ₂	B			d ₁	d _s		
M90×2	120	16	0,6	HMZ18	108	M5	4	6
M95×2	125	17	0,7	HMZ19	113	M5	4	6
M100×2	130	18	0,8	HMZ20	120	M6	4	11
M105×2	140	18	0,9	HMZ21	126	M6	4	11
M110×2	145	19	1	HMZ22	133	M6	4	11
M115×2	150	19	1,1	HMZ23	137	M6	4	11
M120×2	155	20	1,1	HMZ24	138	M6	4	11
M125×2	160	21	1,3	HMZ25	148	M6	4	11
M130×2	165	21	1,3	HMZ26	149	M6	4	11
M135×2	175	22	1,6	HMZ27	160	M6	4	11
M140×2	180	22	1,6	HMZ28	160	M6	4	11
M145×2	190	24	2,2	HMZ29	171	M6	4	11
M150×2	195	24	2,2	HMZ30	171	M6	4	11
M155×3	200	25	2,4	HMZ31	182	M6	4	11
M160×3	210	25	2,6	HMZ32	182	M6	4	11
M165×3	210	26	2,8	HMZ33	193	M8	4	27
M170×3	220	26	2,9	HMZ34	193	M8	4	27
M180×3	230	27	3,2	HMZ36	203	M8	4	27
M190×3	240	28	3,5	HMZ38	214	M8	4	27
M200×3	250	29	3,9	HMZ40	226	M8	4	27
Tr220×4	260	30	3,4	HMZ3044	242	M8	4	27
Tr240×4	290	34	5,4	HMZ3048	270	M10	4	54
Tr260×4	310	34	5,8	HMZ3052	290	M10	4	54
Tr280×4	330	38	6,9	HMZ3056	310	M10	4	54
Tr300×4	360	42	10	HMZ3060	336	M10	4	54
Tr320×5	380	42	10,6	HMZ3064	356	M10	4	54
Tr340×5	400	45	12,1	HMZ3068	376	M12	4	93
Tr360×5	420	45	12,5	HMZ3072	394	M12	4	93
Tr380×5	450	48	16,7	HMZ3076	422	M12	4	93
Tr400×5	470	52	19,1	HMZ3080	442	M16	4	230
Tr420×5	490	52	19,8	HMZ3084	462	M16	4	230

medias ► <https://www.schaeffler.de/std/1EC3>



Main dimensions			Mass m ≈ kg	Designation	Dimensions		Clamping screw Quantity	Maximum tightening torque per clamping screw M _{aL} Nm
G	d ₂	B			d ₁	d ₅		
Tr440×5	520	60	27,8	HMZ3088	490	M16	4	230
Tr460×5	540	60	29,1	HMZ3092	510	M16	4	230
Tr480×5	560	60	30,1	HMZ3096	530	M16	4	230
Tr500×5	580	68	35,7	HMZ30/500	550	M20	4	464
Tr530×6	630	68	46,9	HMZ30/530	590	M20	4	464
Tr560×6	650	75	48,5	HMZ30/560	610	M20	4	464
Tr600×6	700	75	58,7	HMZ30/600	660	M20	4	464
Tr630×6	730	75	61,2	HMZ30/630	690	M20	4	464
Tr670×6	780	80	77,5	HMZ30/670	740	M20	4	464
Tr710×7	830	90	99,5	HMZ30/710	780	M20	4	464
Tr750×7	870	90	105	HMZ30/750	820	M20	4	464
Tr800×7	920	90	111	HMZ30/800	870	M20	4	464
Tr850×7	980	90	119	HMZ30/850	925	M20	4	464
Tr900×7	1030	100	142	HMZ30/900	975	M24	8	798
Tr950×8	1080	100	150	HMZ30/950	1025	M24	8	798
Tr1000×8	1140	100	173	HMZ30/1000	1085	M24	8	798
Tr1060×8	1200	100	184	HMZ30/1060	1145	M24	8	798
Tr1120×8	1260	100	194	HMZ30/1120	1205	M24	8	798
Tr1180×8	1320	100	206	HMZ30/1180	1265	M24	8	798
Tr1250×8	1390	110	245	HMZ30/1250	1335	M24	8	798
Tr1320×8	1460	110	257	HMZ30/1320	1405	M24	8	798
Tr1400×8	1540	110	272	HMZ30/1400	1485	M24	8	798
Tr1500×8	1650	110	312	HMZ30/1500	1595	M24	8	798

medias ► <https://www.schaeffler.de/std/1EC4>





Tab washers

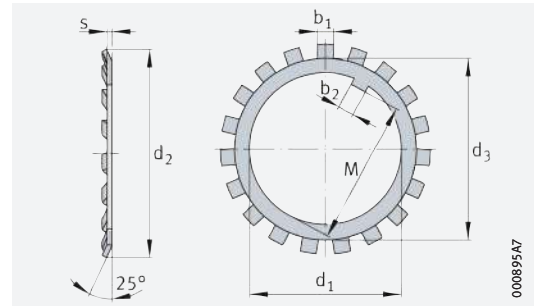

MB, MBL

$d_1 = 10 - 280 \text{ mm}$

Main dimensions			Mass m 100 pieces ≈ kg	Designation	Mounting dimensions			
d_1	d_2 ≈	s			d_3	$b_2^{1)}$	M	b_1
10	21	1	0,13	MB0	13,5	3	8,5	3
12	25	1	0,192	MB1	17	3	10,5	3
15	28	1	0,253	MB2	21	4	13,5	4
17	32	1	0,313	MB3	24	4	15,5	4
20	36	1	0,35	MB4	26	4	18,5	4
25	42	1,25	0,64	MB5	32	5	23	5
30	49	1,25	0,78	MB6	38	5	27,5	5
35	57	1,25	1,04	MB7	44	6	32,5	5
40	62	1,25	1,23	MB8	50	6	37,5	6
45	69	1,25	1,52	MB9	56	6	42,5	6
50	74	1,25	1,6	MB10	61	6	47,5	6
55	81	1,5	1,96	MB11	67	8	52,5	7
60	86	1,5	2,53	MB12	73	8	57,5	7
65	92	1,5	2,9	MB13	79	8	62,5	7
70	98	1,5	3,34	MB14	85	8	66,5	8
75	104	1,5	3,6	MB15	90	8	71,5	8
80	112	1,75	4,64	MB16	95	10	76,5	8
85	119	1,75	5,24	MB17	102	10	81,5	8
90	126	1,75	6,23	MB18	108	10	86,5	10
95	133	1,75	6,7	MB19	113	10	91,5	10
100	142	1,75	7,65	MB20	120	12	96,5	10
105	145	1,75	8,26	MB21	126	12	100,5	12
110	154	1,75	9,4	MB22	133	12	105,5	12
115	159	2	10,8	MB23	137	12	110,5	12
120	151	2	7,7	MBL24	135	14	115	12
	164	2	10,5	MB24	138	14	115	12
125	170	2	11,8	MB25	148	14	120	12
130	161	2	8,7	MBL26	145	14	125	12
	175	2	11,3	MB26	149	14	125	12
135	185	2	14,4	MB27	160	14	130	14

medias ► <https://www.schaeffler.de/std/1EC5>

1) The dimension b_2 can be used as a minimum dimension for the slot width in shafts.



Main dimensions			Mass m 100 pieces ≈ kg	Designation	Mounting dimensions			
d_1	d_2 ≈	s			d_3	$b_2^{1)}$	M	b_1
140	171	2	10,9	MBL28	155	16	135	12
	192	2	14,2	MB28	160	16	135	14
145	202	2	16,8	MB29	171	16	140	14
150	188	2	11,3	MBL30	170	16	145	14
	205	2	15,5	MB30	171	16	145	14
155	212	2,5	20,9	MB31	182	16	147,5	16
160	199	2,5	16,2	MBL32	180	18	154	14
	217	2,5	22,2	MB32	182	18	154	16
165	222	2,5	24,1	MB33	193	18	157,5	16
170	211	2,5	17	MBL34	190	18	164	16
	232	2,5	24,7	MB34	193	18	164	16
180	221	2,5	18	MBL36	200	20	174	16
	242	2,5	26,8	MB36	203	20	174	18
190	231	2,5	20,5	MBL38	210	20	184	16
	252	2,5	27,8	MB38	214	20	184	18
200	248	2,5	21,4	MBL40	222	20	194	18
	262	2,5	29,3	MB40	226	20	194	18
220	292	3	40	MB44	250	24	213	20
240	312	3	40	MB48	270	24	233	20
260	342	3	60	MB52	300	28	253	24
280	362	3	62	MB56	320	28	273	24

medias ► <https://www.schaeffler.de/std/1EC6>

¹⁾ The dimension b_2 can be used as a minimum dimension for the slot width in shafts.





Retaining brackets

With hexagon head cap screw

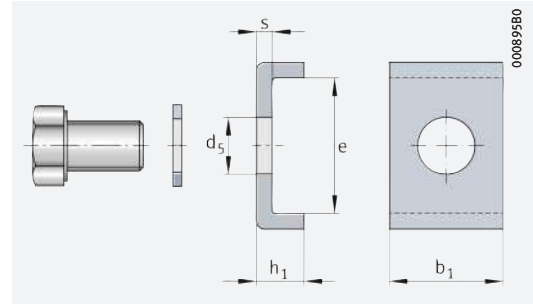

MS30, MS31

b₁ = 20 – 70 mm

Main dimensions			Hexagon head cap screw	Tightening torque	Mass	Designation	Dimensions		Mounting dimensions Shaft slot	
b ₁	e	h ₁					m	s	d ₅	b ₃
				Nm	≈ kg	Complete retaining bracket				
20	13,5	12	M6×10	10	0,026	MS3044	4	7	22	9
	22,5	12	M8×16	25	0,038	MS3144	4	9	22	9
	17,5	12	M8×16	25	0,035	MS3048	4	9	22	9
24	17,5	12	M8×16	25	0,04	MS3056	4	9	26	9
	20,5	12	M8×16	25	0,043	MS3060	4	9	26	9
	25,5	12	M10×20	51	0,056	MS3152	4	11	26	9
	30,5	12	M10×20	51	0,059	MS3160	4	12	26	9
	21	15	M8×16	25	0,057	MS3064	5	9	26	10
	31	15	M10×20	51	0,074	MS3164	5	12	26	10
28	20	15	M8×16	25	0,064	MS3072	5	9	30	10
	24	15	M10×20	51	0,076	MS3076	5	12	30	10
	38	15	M12×22	87	0,115	MS3168	5	14	30	10
32	24	15	M10×20	51	0,085	MS3084	5	12	34	10
	28	15	M12×22	87	0,1	MS3088	5	14	34	10
	40	15	M12×22	87	0,115	MS3176	5	14	34	10
	45	15	M16×25	215	0,154	MS3180	5	18	34	10
36	28	15	M12×22	87	0,109	MS3096	5	14	38	12
	43	15	M16×25	215	0,163	MS3188	5	18	38	10
	53	15	M16×25	215	0,177	MS3196	5	18	38	12
40	45	15	M16×25	215	0,178	MS31/500	5	18	42	12

medias ► <https://www.schaeffler.de/std/1EC7>

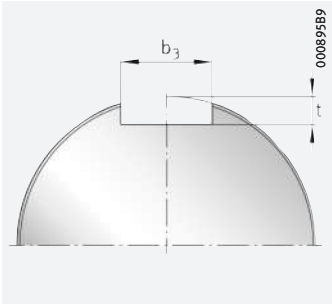

Shaft

Main dimensions			Hexagon head cap screw	Tightening torque	Mass m	Designation	Dimensions		Mounting dimensions Shaft slot	
b_1	e	h_1					s	d_5	b_3	t
40	34	21	M16×25	215	0,223	MS30/530	7	18	42	14
	29	21	M16×25	215	0,212	MS30/560	7	18	42	14
	51	21	M20×40	430	0,347	MS31/530	7	22	42	14
45	34	21	M16×25	215	0,244	MS30/630	7	18	47	14
	39	21	M16×25	215	0,257	MS30/670	7	18	47	14
	54	21	M20×40	430	0,38	MS31/560	7	22	47	14
50	39	21	M16×25	215	0,279	MS30/710	7	18	52	15
	61	21	M20×40	430	0,426	MS31/630	7	22	52	14
	66	21	M20×40	430	0,439	MS31/670	7	22	52	15
55	39	21	M16×25	215	0,301	MS30/750	7	18	57	15
	69	21	M24×45	740	0,58	MS31/710	7	26	57	15
60	51	21	M20×40	430	0,449	MS30/1000	7	22	62	16
	56	21	M20×40	430	0,466	MS30/1500	7	22	62	16
	44	21	M20×40	430	0,426	MS30/850	7	22	62	15
	46	21	M20×40	430	0,433	MS30/950	7	22	62	16
	70	21	M24×45	740	0,614	MS31/750	7	26	62	15
70	88	21	M24×45	740	0,744	MS31/1000	7	26	72	16
	71	21	M24×45	740	0,679	MS31/850	7	26	72	16
	76	21	M24×45	740	0,698	MS31/900	7	26	72	16
	78	21	M24×45	740	0,706	MS31/950	7	26	72	16

medias ► <https://www.schaeffler.de/std/1EC8>



Rolling elements



1	Rolling elements	1750
1.1	Product design	1750
1.2	Dimensions, tolerances	1753
1.3	Design of bearing arrangements	1754



1 Rolling elements



Rolling elements:

- are the connecting elements and contact elements between the stationary and the moving part of a rolling bearing
- essentially determine, due to their geometrical form, the characteristics of the rolling bearing and the bearing type
- are in contact – depending on their shape – with the raceways by means of point contact or line contact ➤ 1750 | ①
- are available as steel balls, cylindrical rollers and needle rollers
 - steel balls are used where moderate to high speeds occur and moderate to high axial forces and radial forces must be supported ➤ 1751 | ②
 - cylindrical rollers are used where bearing arrangements are subjected to radial and axial load ➤ 1752 | ③
 - needle rollers are particularly suitable where the radial design envelope is restricted and the radial loads are lower than those in bearing arrangements with cylindrical rollers ➤ 1753 | ④
- are used in the design of compact bearing arrangements with very high load carrying capacity with a full complement of balls, rollers or needle rollers ➤ 1754 | ⑤.

① 1
Point or line contact

Q = rolling element load

- ① Ball (point contact)
- ② Cylindrical roller (line contact)
- ③ Needle roller (line contact)

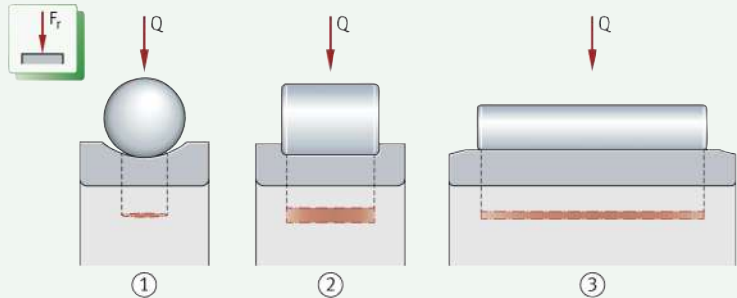

1.1 Product design

Always enquire about the possible supply of rolling elements



The description of the rolling elements in this chapter gives information about the fundamental characteristics and designs of the products.



A specific enquiry must always be placed on Schaeffler regarding the sale and possible supply of loose rolling elements for a specific application.

Basic elements of ball bearings

Steel balls

Steel balls are made from through hardened rolling bearing steel in accordance with DIN EN ISO 683-17 and are the basic elements of ball bearings ► 1751 | 2.

Steel balls

F_r = radial load

F_a = axial load

① Deep groove ball bearing

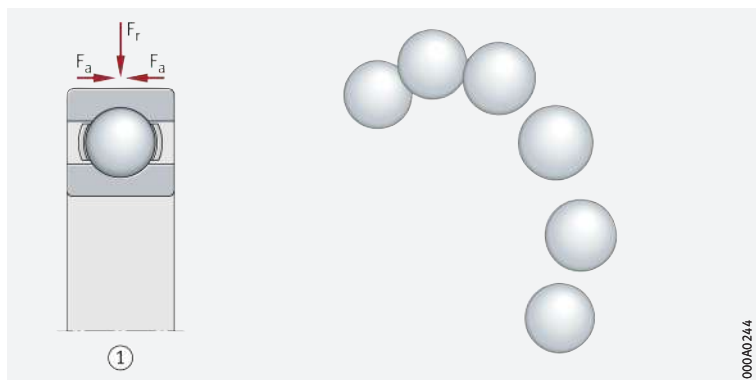

Available grades

Balls are available in the grades G10, G16, G20. The largest and smallest deviation and the geometrical tolerance are defined as a function of the diameter D_w .

Sorting by ball sorts and preferred sort pairs

Balls manufactured under identical conditions (known as batches) are sorted within a class into ball sorts with a very small diameter tolerance according to the mean batch diameter D_{wML} . Each sort is packed separately and the mean deviation is marked on the packaging. One pack contains balls of one sort only. In a delivery of balls of the same nominal dimension and class comprising several packs, the sort may differ from one pack to another. Preferred sort range of grades G10 to G20: +6 to -6.

Designation of sorts

The designation of the ball sort (N, P or M) is printed on the packaging:

- N for zero
- P for a positive value (stating the value)
- M for a negative value (stating the value).



Balls of only one sort should always be used in one bearing arrangement.



By agreement, balls made from other materials, such as special steels or ceramic, can be supplied.

Areas of application

Balls are used:

- in rolling bearings where moderate to high speeds occur and moderate to high axial forces and radial forces must be supported, for example in deep groove ball bearings, slewing rings, rotor bearings and linear guidance systems ► 1751 | 2
- for standard applications
- where the bearing position is required to operate with little noise.



Basic elements of cylindrical roller bearings

Cylindrical rollers

Cylindrical rollers are made from through hardened rolling bearing steel in accordance with DIN EN ISO 683-17 and are the basic elements of cylindrical roller bearings ▶ 1752 | 3. The profile has a logarithmic curve. In conjunction with the profiling of the raceways, this prevents edge stresses.

Cylindrical rollers
 F_r = radial load
 F_a = axial load
 ① Cylindrical roller bearing

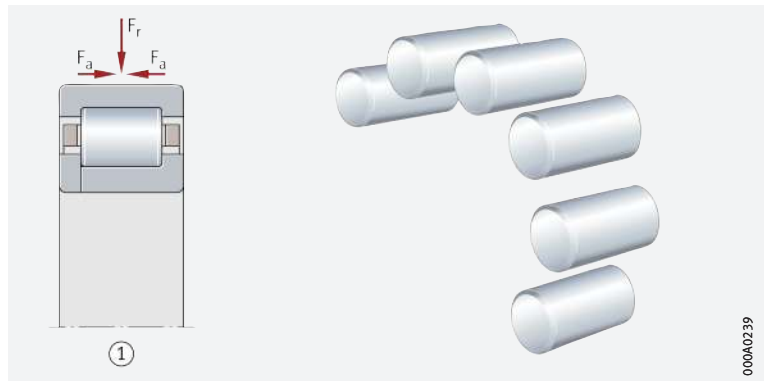

Sorting by sorts

Cylindrical rollers are divided into sorts with very small diameter and length tolerances. The sorting is indicated on the packaging. One pack contains cylindrical rollers of one sort only. In a delivery comprising several packs, the sort may differ from one pack to another.

Designation of sorts

The designation of the sort (0, + or -) is printed on the packaging:

- 0 for zero
- + for a positive value (stating the value)
- - for a negative value (stating the value).



Cylindrical rollers of only one sort should always be used in one bearing arrangement.



For available sizes and possible special designs, please enquire with Schaeffler.

Areas of application



Cylindrical rollers are used:

- where bearing arrangements are subjected to very high radial loads ▶ 1752 | 3. In the case of a bearing arrangement under combined load (axial/radial), the transmission of moderate axial forces is possible taking account of the adjacent construction; axial load carrying capacity of cylindrical roller bearings ▶ 417 | 1.2
- in the automotive industry as well as in machine and gearbox building
- in linear guidance systems.

Basic elements of needle roller bearings

Needle rollers

Needle rollers are made from through hardened rolling bearing steel 100Cr6 in accordance with DIN EN ISO 683-17 and are the basic elements of needle roller bearings ▶ 1753 | 4. The needle rollers have profiled ends with flat end faces (end faces = type B). Due to this profiling, the outside surfaces have a curved transition to the ends. This reduces the edge stresses at the ends of the rolling elements. Needle rollers can only support radial loads.

4
Needle rollers

F_r = radial load

① Needle roller bearing

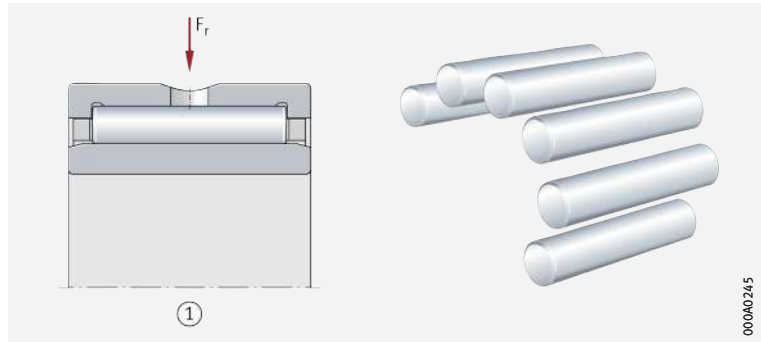

Sorting by sorts

Needle rollers are divided into sorts with very small diameter tolerances. The sorting is indicated on the packaging. One pack contains needle rollers of one sort only. In a delivery comprising several packs, the sort may differ from one pack to another.



Needle rollers of only one sort should always be used in one bearing arrangement.



For available sizes and possible special designs, please enquire with Schaeffler.

Areas of application

Needle rollers are used:

- for full complement needle roller bearing arrangements subjected to radial load (where the loads are not as high as those on cylindrical roller bearings).

1.2 Dimensions, tolerances

Steel balls



The dimensional and geometrical tolerances of steel balls correspond to DIN 5401/ISO 3290-1.

Cylindrical rollers



The standard grade of cylindrical rollers corresponds to GN in accordance with DIN 5402-1. The design of chamfer dimensions, length tolerances and diameter tolerances of cylindrical rollers is based on DIN 5402-1.

Needle rollers



The dimensional and geometrical accuracy of needle rollers corresponds to DIN 5402-3/ISO 3096.



1.3 Design of bearing arrangements

Design of full complement ball, roller and needle roller bearing arrangements

The rolling elements can be used in the design of full complement ball, roller and needle roller bearing arrangements ▶ 1754 | 5. Since these bearing arrangements completely fill the design envelope with rolling elements, they are particularly compact and have high load carrying capacity and high rigidity. Due to the kinematic conditions in the bearing, however, the speed suitability of such bearing arrangements is not as high as that of comparable bearings with cages. The rolling elements described here allow bearing arrangements with high radial runout accuracy and an adjustable internal clearance (depending on the geometrically accurate design of the raceways).

Areas of application

Such bearing arrangements are used in preference:

- in bearing positions with swivel motions
- where high to very high loads occur
- where only a small design envelope is available.



Bearing arrangements with a full complement of balls, rollers or needle rollers require a raceway on the shaft and in the housing that is hardened and ground (which can be used as a rolling element raceway). Bearing arrangements with needle rollers can only be subjected to radial load ▶ 1753.



For information on the design of bearing arrangements and the permissible speeds, please contact Schaeffler.



Full complement needle roller bearing arrangement

- D_w = rolling element diameter
- E = raceway diameter of housing bore
- F = raceway diameter of shaft
- TES = circumferential clearance
- Z = rolling element
- ① Radial operating clearance

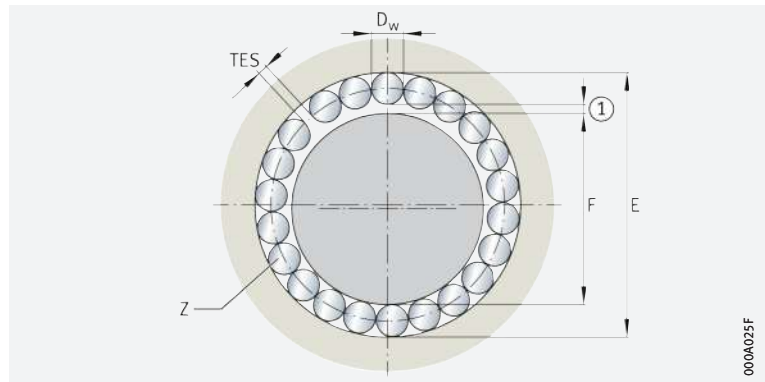



Other products

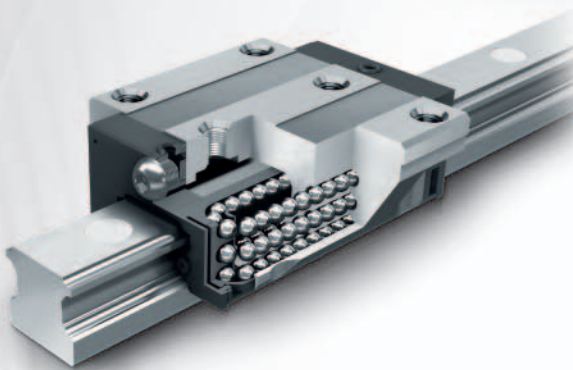

1 Modular sensor bearings **1758**

- 1.1 FAG VarioSense bearings 1758
- 1.2 Further information 1761

2 Slewing rings **1762**

- 2.1 General features 1762
- 2.2 Four point contact bearings 1762
- 2.3 Crossed roller bearings 1763
- 2.4 Printed and electronic product catalogue 1763

3 Thin section bearings **1764**

- 3.1 General features 1764
- 3.2 Deep groove ball bearings, four point contact bearings, angular contact ball bearings 1765
- 3.3 Product catalogue 1765



4 Linear guidance systems and linear systems **1766**

- 4.1 Monorail guidance systems _____ 1766
- 4.2 Hydrostatic compact guidance system _____ 1769
- 4.3 Shaft and track roller guidance systems _____ 1771
- 4.4 Flat cage and recirculating roller guidance systems _____ 1772
- 4.5 Miniature guidance systems _____ 1774
- 4.6 Screw drives _____ 1775
- 4.7 Driven linear units _____ 1777

5 Spherical plain bearings, rod ends **1780**

- 5.1 Spherical plain bearings, maintenance-free _____ 1780
- 5.2 Spherical plain bearings, requiring maintenance _____ 1783
- 5.3 Rod ends, maintenance-free _____ 1785
- 5.4 Rod ends, requiring maintenance _____ 1787
- 5.5 Hydraulic rod ends, requiring maintenance _____ 1789

6 Composite plain bearings with plain bushes **1791**

- 6.1 Metal/polymer composite plain bearings _____ 1791
- 6.2 ELGOTEX filament wound bushes, maintenance-free or water-resistant _ 1796
- 6.3 ELGOGLIDE plain bushes, maintenance-free _____ 1798
- 6.4 Plain bearings for diverse requirements _____ 1800

1 Modular sensor bearings

1.1

FAG VarioSense bearings

🔗 *Newly developed product series*

With the FAG VarioSense bearing, Schaeffler is now introducing a product series that, through the combination of standard rolling bearings and a modular sensor concept, facilitates a flexible, rapid and economical solution for the collection of measurement values such as speeds, displacements or temperatures. Due to the high precision of the rolling bearings and the accuracy of the adjacent construction, the bearing position is often the ideal location for collecting these data.

In a first stage, deep groove ball bearings and the measurement values of speed, bearing temperature and radial displacement are being offered, where the measurement of displacement allows a conclusion to be drawn as to the load on the bearing. The customer can then, depending on his requirements, select a configuration that contains precisely the sensor functions required.

🔗 *Expansion of the product series*

The modular concept of the sensor unit facilitates implementation in the future of further sensor functions, such as vibration measurement, or a variant with wireless signal transmission. Schaeffler is already working on the expansion of the FAG VarioSense bearing to include other bearing types and sizes as well as other sensor functions.



This catalogue describes the FAG VarioSense bearings available at the time of printing. We will be pleased to give you information about the expanded scope of the product range as a result of future developments.

🔗 *Modular sensor concept*

Structure

A fundamental feature of the FAG VarioSense bearing is its modular sensor concept ▶ 1758|📐 1, which allows configuration of the sensors that is flexibly and ideally matched to the application.



Modular sensor concept

- ① Rolling bearing
- ② Measurement ring
- ③ Sensor cluster



The following sections describe the product portfolio available as standard. For requirements extending beyond these or where there is a need for customer-specific product configurations, please consult Schaeffler.

🔗 *Components*

The sensors for the collection of measurement values are integrated in a sensor unit fitted on the side of the bearing ▶ 1759|📐 2. This is connected via a cable by means of a detachable plug connection with an interface unit. This carries out conversion and preparation of the measurement signals resulting from the measurement of temperature, displacement and speed. The interface unit also has an LED for display of the operating mode and a flange plug for customer-side connection.

If a product configuration is selected that includes speed measurement as the only sensor function, the interface unit is not necessary and the plug connection is optional.

2
Components

- ① Sensor unit
- ② Rolling bearing
- ③ Cable
- ④ Detachable plug connection
- ⑤ Interface unit
- ⑥ Customer-side connection
- ⑦ LED for operating mode

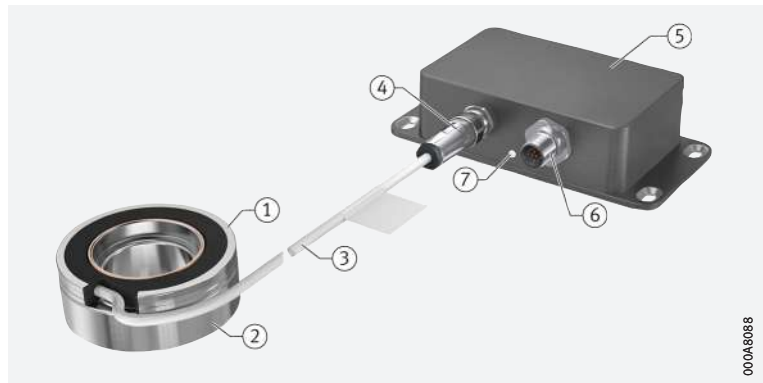

Sensor functions

The FAG VarioSense bearing can be equipped with sensors for speed, temperature and displacement. All the sensors are integrated in the sensor unit.

- Speed measurement
- Temperature measurement
- Displacement measurement

The speed sensor records the signals from a magnetic scale that is connected to the inner ring of the bearing. As an output signal, the sensor delivers two phase-offset signals. With the aid of the signals, speeds of up to 15 000 min⁻¹ as well as the direction of rotation can be determined.

The temperature sensor records the temperature in the vicinity of the bearing outer ring. The resolution is 0,5 K.

In the measurement of displacement, the radial displacement between the inner ring and outer ring is recorded. From this, information can be derived about the load on the bearing and the adjacent construction. The measurement of displacement is subject not only to the radial load but also to a series of other influences such as axial load, tilting and temperature. These influences must be taken into consideration in the interpretation of the measurement results.



In order to ensure correct interpretation of the displacement measurement in relation to the bearing load, we recommend comprehensive analysis of the application and advisory work by Schaeffler.

- Versatile combination of different sensors

Product variants

The concept of the FAG VarioSense bearing allows the versatile combination of different sensors. Each combination of sensors is assigned a product configuration. The product configurations available as standard are shown below ► 1759 | 1.

Further combinations of the available sensor functions are available by agreement.

1
Product configurations

● = component of product configuration

Product configuration	Sensor			Interface unit
	Speed	Temperature	Displacement	
001	●	–	–	Optional
002	●	●	–	●
003	●	●	●	●

- Variation of other product characteristics

In addition to the combination of sensors, the selection of an FAG VarioSense bearing allows the variation of other product characteristics such as the sealing of the bearing or the internal clearance.

Interfaces

The interface unit forms the interface between the sensor unit fitted to the bearing on the one hand and the customer system for processing of the measurement results on the other hand.

☞ Interfaces of interface unit

All product variants that have at least one more sensor function in addition to speed measurement are equipped with an interface unit.

The interface unit has the following interfaces ▶ 1760 | 3:

- flange socket for connection of the sensor unit.
- flange plug for the customer-side connection. This interface is used for the output of measurement signals and status as well as the supply of voltage.
- USB communication interface, integrated in the flange plug for customer-side connection. This interface is provided for installing new software versions and for reading out the error and status memory from service activities.
- RS485 interface, integrated in the flange plug for customer-side connection. This interface is used for the exchange of measurement values.
- LED for display of the operating and error status. Display is carried out by means of different colour and flashing modes.



End face of interface unit

- ① Flange socket for connection of the sensor unit
- ② LED for operating mode
- ③ Flange plug for customer-side connection, with integrated USB communication interface and integrated RS485 interface

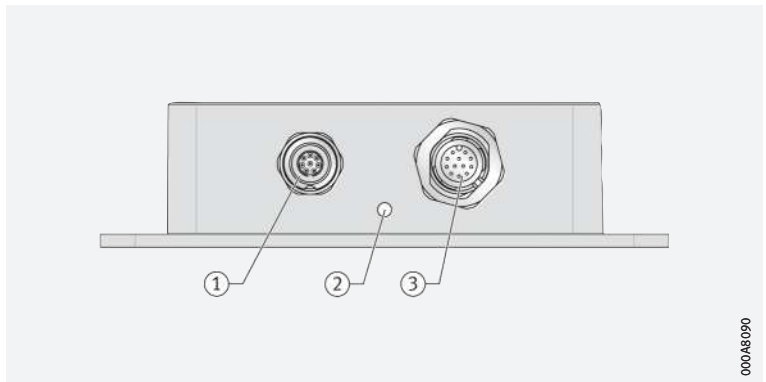

Rolling bearings

The product series FAG VarioSense currently includes the following standard rolling bearings with integrated sensor technology:

- single row deep groove ball bearings of Generation C in the sizes 6205-C to 6210-C.

For the future, the intention is to expand the product series FAG VarioSense to include other rolling bearings.

☞ Deep groove ball bearings of Generation C

Deep groove ball bearings of Generation C correspond in their structure to single row standard deep groove ball bearings but are specially optimised in relation to:

- significantly quieter running
- even more effective sealing
- a further reduction in the already very low frictional torque.

These optimisations were achieved by means of design modifications such as new seals and cages, improvements in bearing kinematics and refined manufacturing processes.

☞ Sealing of bearings

Within the product series FAG VarioSense, deep groove ball bearings are available with the following seals:

- gap seal 2Z on both sides
- lip seal 2HRS on both sides.

Lubricating greases

Within the product series FAG VarioSense, deep groove ball bearings can be supplied with various lubricating greases in accordance with customer requests. Selection of the lubricating grease is based on the information given in the Technical Product Information ►  TPI 165.



Upon customer request, other lubricating greases are also available, however these must be checked in advance in conjunction with the sensor unit. If necessary, please contact Schaeffler.



Detailed information on deep groove ball bearings of Generation C is given in the Technical Product Information ►  TPI 165 and the Rolling Bearings Catalogue HR 1 ► 208.

Temperature limits

The maximum storage and operating temperatures are dependent on the sensors used and therefore differ in accordance with the product configuration ► 1761 |  2.

 2
Temperature limits
of sensor and interface unit

Component		Temperature			
		Storage		Operation	
		min. °C	max. °C	min. °C	max. °C
Sensor unit of product configuration	001	+5	+40	-40	+125
	002	+5	+40	-40	+125
	003	+5	+40	-40	+105
Interface unit		+5	+40	-40	+80



In addition to the temperature limits of the sensor and interface unit, the permissible operating temperature of the bearing must always also be taken into consideration.

1.2 Further information



In the selection of an FAG VarioSense bearing for an application, in the design of the adjacent construction and incorporation in the overall system, not only the information in this chapter but also the information in the following publication must also be observed:

- Technical Product Information ►  TPI 253
- Download and ordering via ► <https://www.schaeffler.de/std/1D56>

2 Slewing rings

☞ *Design variants*

- Slewing rings are available as:
- four point contact bearings ▶ 1762 | ☞ 1
 - crossed roller bearings ▶ 1763 | ☞ 2.

2.1

General features

☞ *Suitable for radial, axial and tilting moment loads*

Schaeffler slewing rings are known worldwide as premium products in the field of rolling bearing technology. They have proved themselves in numerous ways, have high load carrying capacity, a versatile range of applications and are highly cost-effective. Due to their design, a single bearing position can reliably support radial, axial and tilting moment loads. As a result, bearing arrangements comprising a combination of radial and axial bearings can often be reduced to a single bearing position. This reduces, in some cases considerably, the costs and work required in the design of the adjacent construction and the fitting of bearings.

☞ *Sealed on both sides and greased*

Slewing rings are sealed on both sides, lubricated with a high quality grease, can be relubricated via lubrication nipples and are particularly easy to fit.

☞ *Rings with or without gear teeth*

The bearing rings are supplied without gear teeth or – in order to achieve simple drive solutions – are available with external or internal gear teeth.

2.2

Four point contact bearings

☞ *For lower requirements for load carrying capacity, accuracy and rigidity*

Four point contact bearings are available with external teeth, internal teeth or without teeth as well as in the light series 20 and in the standard series 20 and 25 ▶ 1762 | ☞ 1. These slewing rings without preload are robust and proven under very demanding operation; they place only slight demands on the flatness and perpendicularity of the adjacent construction. They are suitable for applications with lower requirements for accuracy and rigidity of the bearing arrangement, for example in simple metalworking machines, wind turbines and construction machinery.



Four point contact bearings

- F_a = axial load
- F_r = radial load
- M = tilting moment

- ① Bearing without gear teeth
- ② Bearing with internal gear teeth

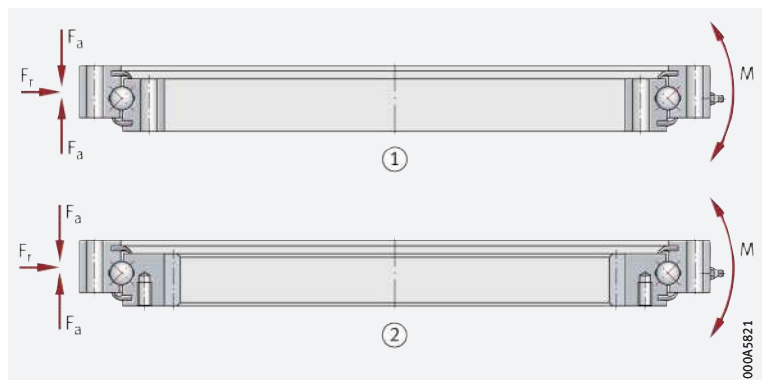

000A5821

2.3 Crossed roller bearings

Higher load carrying capacity than four point contact bearings

Designed for high precision applications

Crossed roller bearings are available with external gear teeth, internal gear teeth and without gear teeth in the standard series 14, as well as in the series XA, XI and XU ▶ 1763 | 2. These preloaded slewing rings can support higher loads than four point contact bearings. They have proved themselves particularly effective where bearings are subjected to high radial forces, as well as to moderate axial and tilting moment loads.

The bearings are suitable for applications with uniform running free from stick-slip, low rotational resistance and high requirements for axial and radial runout accuracy and rigidity, for example in robots, handling systems and machine tools.

2 Crossed roller bearings

F_a = axial load

F_r = radial load

M = tilting moment

① Bearing without gear teeth

② Bearing with external gear teeth

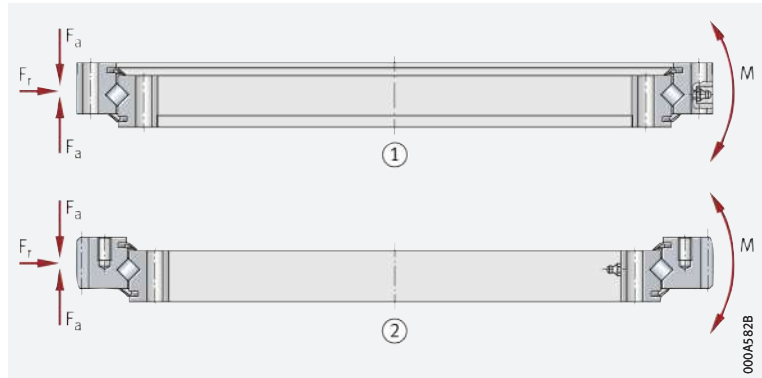

2.4 Printed and electronic product catalogue



The standard range of these four point contact and crossed roller bearings is described in detail in the catalogue Slewing Rings ▶ 404 and in our electronic product catalogue **medias professional**. The printed catalogue can be requested from Schaeffler.



The following link will take you to the electronic product catalogue:
▶ <https://medias.schaeffler.com>

3 Thin section bearings

Design variants

Thin section bearings are available as:

- deep groove ball bearings (type C) ▶ 1764 | 1
- four point contact bearings (type X) ▶ 1764 | 1
- angular contact ball bearings (type E) ▶ 1764 | 1.

3.1 General features

Bearings with an extremely small cross-section for light-weight designs with reduced design envelope

Thin section bearings are high precision products with very little running noise and very high load carrying capacity. These ball bearings are available in three different designs with an extremely small, predominantly square cross-section ▶ 1764 | 1. Within each series, the cross-section remains constant even in the case of larger shaft and housing bore diameters. The bearings are therefore also described as Constant Section (CS) bearings. This feature distinguishes thin section bearings from the conventional bearings that are described in standardised ISO series. In this way, a larger cross-section can be selected in a graduated way and thus a bearing with higher load carrying capacity can be used without the need to change the shaft diameter. Thin section bearings can thus be used to achieve extremely light and compact designs.

Available open or sealed, with cages made from brass or plastic

Thin section bearings are available in designs that are either open or sealed on both sides. The seals are made from synthetic rubber (NBR) and have a steel insert. Sealed bearings are greased. For extreme operating conditions, special lubricants are available. Cages are made from brass or plastic.

Tolerance classes

In addition to the standard tolerance class PL1, the classes PL3 and PL6 are available (with increasingly narrow tolerances).

1 Thin section bearings

F_a = axial load

F_r = radial load

α = nominal contact angle

① Deep groove ball bearing

② Four point contact bearing

③ Angular contact ball bearing

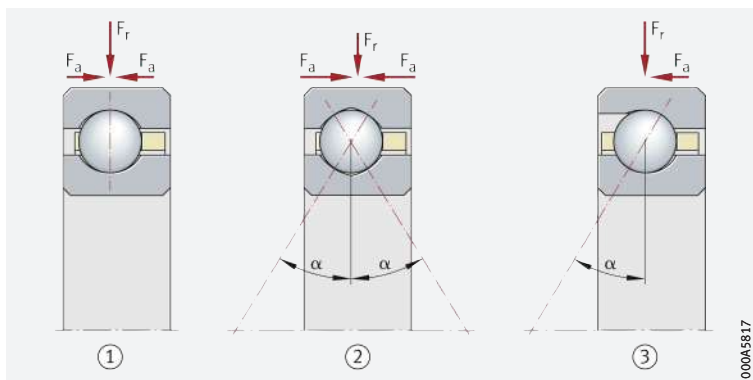

3.2 Deep groove ball bearings, four point contact bearings, angular contact ball bearings

Each of the designs is available in various series. The series correspond to the cross-section sizes. The balls are matched to the series.

Deep groove ball bearings

 *Suitable for radial and axial loads*

Deep groove ball bearings (type C) can support axial loads in both directions as well as radial loads; under axial load, a contact angle ($\alpha > 0^\circ$) is adopted.

Four point contact bearings

 *Action similar to double row angular contact ball bearings*

Four point contact bearings (type X) can support axial loads in both directions as well as radial loads. As a result, they act in the same way as double row angular contact ball bearings.

Angular contact ball bearings

 *Suitable for high radial and axial loads*





















Angular contact ball bearings (type E) can be filled with an increased number of balls and have a nominal contact angle of $\alpha = 30^\circ$. They can support considerably higher radial loads than deep groove ball bearings or four point contact bearings and can support axial loads in one direction. For particular requirements, angular contact ball bearings are also available as matched pairs of bearings. These combinations then have a significantly higher rigidity and load carrying capacity than individual bearing solutions.

3.3 Product catalogue



The standard range of these bearings is described in detail in the product catalogue ►  575. The catalogue can be requested from Schaeffler.

4 Linear guidance systems and linear systems

-  **Design variants** Linear guidance systems and linear systems are available as:
- monorail guidance systems
 - linear recirculating roller bearing and guideway assemblies ► 1767 |  1
 - six-row linear recirculating ball bearing and guideway assemblies ► 1768 |  2
 - four-row linear recirculating ball bearing and guideway assemblies ► 1768 |  3
 - hydrostatic compact guidance system ► 1769 |  4
 - shaft and track roller guidance systems
 - shaft guidance systems ► 1771 |  6
 - track roller guidance systems ► 1772 |  8
 - flat cage and recirculating roller guidance systems
 - flat cage guidance systems ► 1773 |  9
 - linear recirculating roller guidance systems ► 1773 |  10
 - miniature guidance systems
 - two-row miniature linear recirculating ball bearing and guideway assemblies ► 1774 |  11
 - four-row miniature linear recirculating ball bearing and guideway assemblies ► 1774 |  12
 - miniature carriage units ► 1775 |  13
 - screw drives
 - ball screw drives ► 1775 |  14
 - roller screw drives ► 1775 |  14
 - planetary screw drives ► 1775 |  14 and ► 1777 |  15
 - driven linear units
 - linear actuators ► 1778 |  16, ► 1778 |  17, ► 1778 |  18
 - linear tables ► 1779 |  19.

4.1 Monorail guidance systems

 **Features** Monorail guidance systems from Schaeffler are compact linear guidance systems based on rollers or balls and have high rigidity and high load carrying capacity. These guidance systems can support forces from all directions, except for the direction of motion, and moments about all axes. They are available in various accuracy and preload classes and are therefore also suitable for applications with high guidance and positioning requirements.

Monorail guidance systems are based on a modular concept; this means that, within one size, guideways can be combined with all carriage types. This gives more economical stockholding, simpler fitting and more rapid spare parts purchasing.

In order to reduce maintenance intervals and maintenance costs, monorail guidance systems have a lubricant reservoir. Sealing of the carriages on all sides protects the rolling element systems against contamination even under critical ambient conditions.



The complete standard range of monorail guidance systems is described in detail in the catalogue Monorail Guidance Systems ►  PF 1 and in the online version **medias professional** ► <https://medias.schaeffler.com>.

Very high load carrying capacity, very high rigidity

Linear recirculating roller bearing and guideway assemblies

Linear recirculating roller bearing and guideway assemblies RUE are, due to the cylindrical rollers, the monorail guidance systems with the highest load carrying capacity and rigidity from Schaeffler ▶ 1767 | 1. They comprise at least one carriage with a full complement roller system, a guideway, integral elastic wipers on the end faces of the carriage, sealing strips on the upper side and underside of the carriage and closing plugs to close off the fixing holes in the guideway.



Linear recirculating roller bearing and guideway assemblies RUE

F_y, F_z = load-bearing component in y and z direction

M_x, M_y, M_z = moment about x, y and z axis

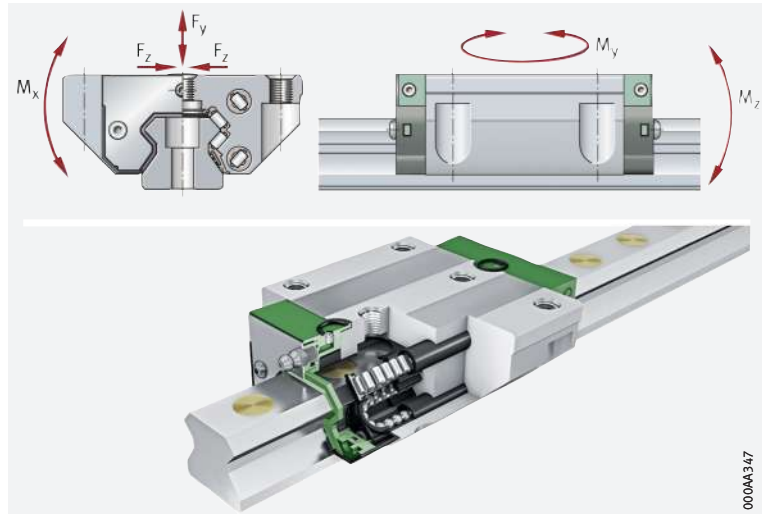

The carriage and guideway of a linear recirculating roller bearing and guideway assembly are matched to each other due to their closely toleranced preload. It may be possible, after consultation, to use carriages and guideways in different combinations.

Suitability

Linear recirculating roller bearing and guideway assemblies are suitable for accelerations up to 100 m/s^2 , velocities up to 180 m/min and operating temperatures between -10 °C and $+100 \text{ °C}$. They are used in applications with long unrestricted strokes, high and very high loads and high to very high rigidity.

Linear recirculating ball guidance systems with high load carrying capacity and high rigidity

Six-row linear recirculating ball bearing and guideway assemblies

Six-row linear recirculating ball bearing and guideway assemblies KUSE are the guidance systems based on balls with the highest load carrying capacity and rigidity ▶ 1768 | 2. They comprise at least one carriage with a full complement ball system, a guideway, integral elastic wipers on the end faces of the carriage, sealing strips on the underside of the carriage and plastic closing plugs.



Six-row linear recirculating ball bearing and guideway assemblies KUSE

F_y, F_z = load-bearing component in y and z direction

M_x, M_y, M_z = moment about x, y and z axis

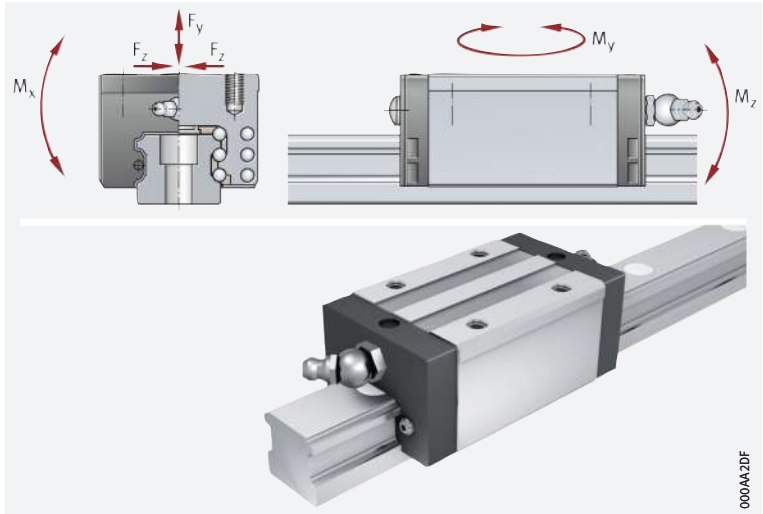

Suitability

Linear recirculating ball bearing and guideway assemblies KUSE are suitable for accelerations up to 150 m/s^2 , velocities up to 300 m/min and operating temperatures between $-10 \text{ }^\circ\text{C}$ and $+100 \text{ }^\circ\text{C}$. They are used in applications with long unrestricted strokes, high and very high loads and high to very high rigidity.

Very extensive range

Four-row linear recirculating ball bearing and guideway assemblies

Four-row linear recirculating ball bearing and guideway assemblies KUBE are the most versatile and most extensively developed range of monorail guidance systems available from Schaeffler ▶ 1768 | 3. These units comprise at least one carriage with a full complement ball system, a guideway, integral elastic wipers on the end faces of the carriage, sealing strips on the upper and lower sides of the carriage and plastic closing plugs.



Four-row linear recirculating ball bearing and guideway assemblies KUBE

F_y, F_z = load-bearing component in y and z direction

M_x, M_y, M_z = moment about x, y and z axis

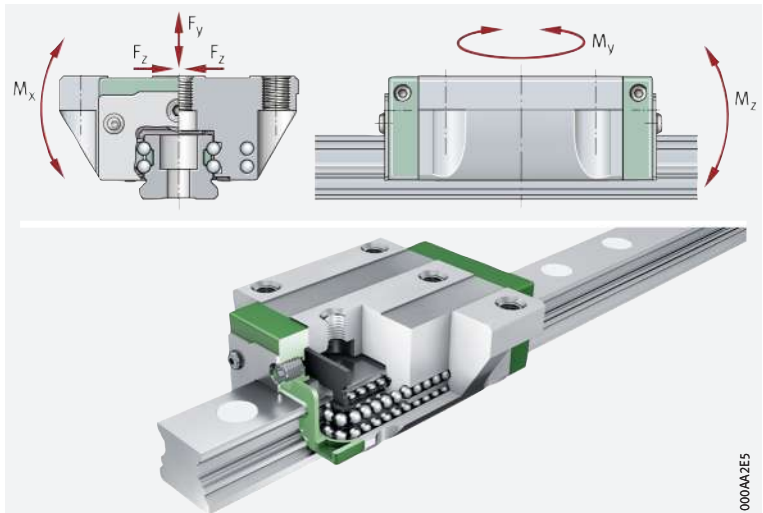

Suitability

Linear recirculating ball bearing and guideway assemblies KUBE are suitable for accelerations up to 150 m/s^2 , velocities up to 300 m/min and operating temperatures between $-10 \text{ }^\circ\text{C}$ and $+100 \text{ }^\circ\text{C}$. They are used in applications with long unrestricted strokes, high loads, high rigidity and low friction.

Four-row linear recirculating ball bearing and guideway assembly of High-Speed design

Interchangeable with comparable KUVE units

X-life

High dynamic characteristics

High-Speed for highly dynamic requirements

The four-row, full complement linear recirculating ball bearing and guideway assembly KUVE..-B-HS of the High-Speed design represents a further expansion of the extensive KUVE range in the field of highly dynamic applications. This variant is extremely robust and is one of the fastest four-row linear recirculating ball bearing and guideway assemblies on the market. Depending on the operating conditions, velocities of up to 10 m/s are possible.

In order to achieve these values, the end piece and ball return system in the High-Speed design were redesigned, as a result of which the total length of the carriage is slightly larger in comparison with the standard design. The design envelope corresponds to DIN 645-1.

The loads are supported by standard steel rolling elements. The linear recirculating ball bearing and guideway assembly of the High-Speed design is interchangeable with the comparable KUVE-B units.

The linear recirculating ball bearing and guideway assemblies are supplied in X-life premium quality. These bearings are characterised by improved technological features, increased robustness and longer operating life. Further information on X-life ► 10.

Linear recirculating ball bearing and guideway assemblies of the High-Speed design are used in applications with very high dynamic requirements. Since hybrid technology has not been used in this case, the full performance capacity of the rolling contact can be implemented – with the associated advantages in terms of load carrying capacity, rigidity, robustness and crash safety.



The High-Speed linear recirculating ball bearing and guideway assemblies are described in detail in the Technical Product Information ► TPI 145 and in the online version *medias professional*.

4.2

Hydrostatic compact guidance system

The carriages in monorail guidance systems cannot accommodate vibration damping. In order to allow appropriate damping of vibrations from the adjacent construction, additional elements such as the passive damping carriage RUDS-D for linear recirculating roller bearing and guideway assemblies RUE-E are necessary, which is positioned between the carriages. In order to have the greatest effect when bending vibrations occur, however, the damping element must be positioned at the point of largest deflection. A good knowledge of the vibration patterns is therefore required.

Hydrostatic vibration damping by means of oil cushion

For applications with very high demands on damping, dynamic rigidity and load carrying capacity, there is now a hydrostatic compact guidance system based on our proven linear recirculating roller bearing and guideway assemblies RUE..-E for size 45 ► 1769 | 4.



Hydrostatic compact guidance system HLE45-A-XL



000874E

Functional principle A chamber system in the carriage is charged with hydraulic oil. The oil is fed to the pressure side under continuous pressure, thus filling the pressure pockets [▶ 1770](#) | [□ 5](#). The integrated chokes are set such that the pressure pockets in the carriage are subjected uniformly to pressure. The unpressurised oil is extracted from the compact guidance system on the suction side and fed back to the oil circuit.

[□ 5](#)
Functional parts

- ① Pressure side
- ② Integrated choke
- ③ Pressure pockets
- ④ Extraction side (unpressurised area)

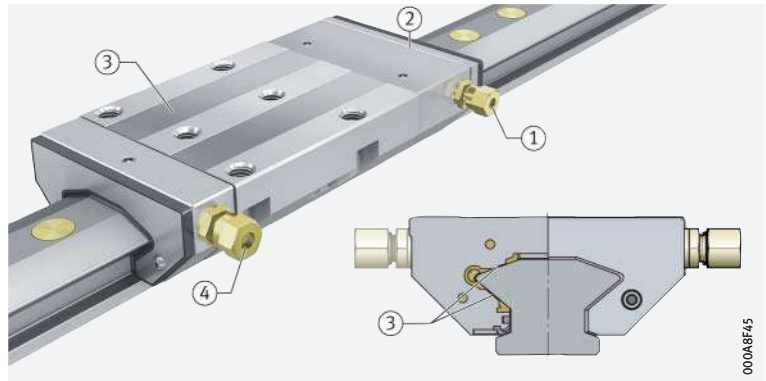

X-life premium quality



Hydrostatic compact guidance systems HLE45-A-XL are supplied in X-life quality. Further information on X-life [▶ 10](#).

Increased customer benefits due to X-life

The guidance systems combine damping values of more than 470 000 kg/s with levels of tensile/compressive rigidity that are almost as high as the rigidity of the corresponding rolling element guidance systems. When used in machine tools, this gives higher cutting output, better surface quality and longer tool life.

A special bronze coating in the pressure pockets of the saddle plate gives excellent emergency running characteristics, which means that the guidance system is not damaged even when overloaded or during operation without hydraulic pressure.

Performance characteristics

There is approximately zero friction between the guideway and the carriage. The compressive rigidity corresponds to the normal linear recirculating roller bearing and guideway assembly RUE-E. The operating load in machine tools is similar to the standard monorail guidance system. The guidance system can support loads from all directions, apart from the direction of motion, and moments about all axes. It is suitable for accelerations of 100 m/s² and velocities up to 120 m/min.



The hydrostatic compact guidance systems are described in detail in the Technical Product Information [▶ □ TPI 149](#).

4.3 Shaft and track roller guidance systems

Shaft guidance systems

Linear guidance systems based on ball bearings or plain bearings

Shaft guidance systems from Schaeffler are linear guidance systems based on ball bearings or plain bearings for various areas of use and applications. Linear ball bearings are available as a light range, compact range and machined range. The mating tracks may be in the form of solid shafts, hollow shafts or supported shaft and support rail units ▶ 1771 | 6 and ▶ 1771 | 7.

6 Shaft guidance system WL, closed housing

F_y = load-bearing component in y direction

- ① Linear ball bearing in closed housing
- ② Closed linear ball bearing
- ③ Shaft guidance system with linear ball bearing and solid shaft

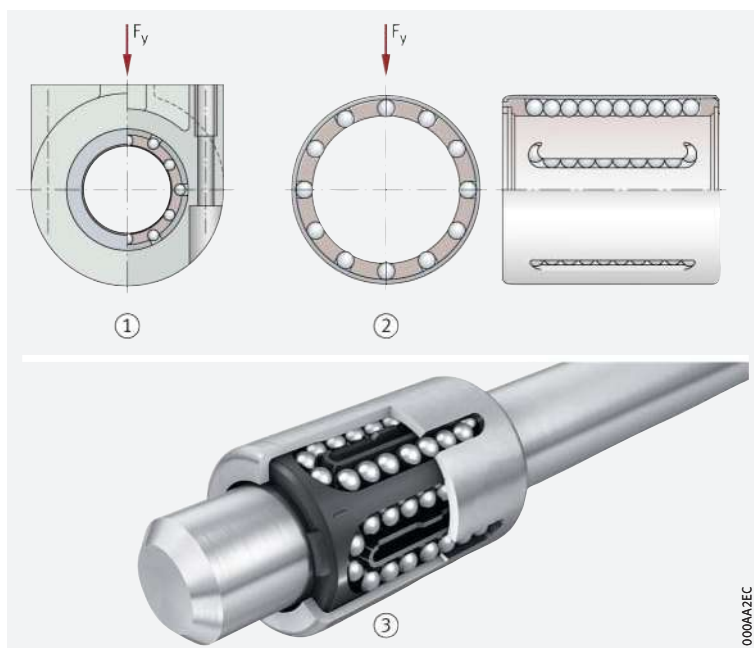

7 Shaft guidance system WL, housing with segment cutout, supported shaft and support rail unit

F_y = load-bearing component in y direction

- ① Linear ball bearing in housing, segment cutout for supported shafts
- ② Shaft and support rail unit with solid shaft

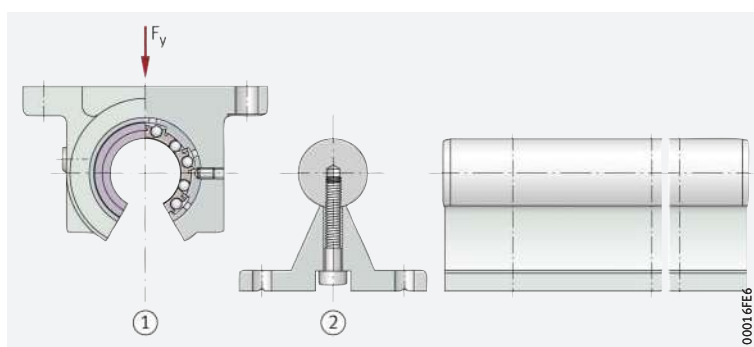

The range is rounded off by a large selection of linear ball bearing and housing units and linear plain bearing units. In this case, the linear ball bearings or linear plain bearings are already mounted in ready-to-fit housings.

A large number of shafts (with and without machined features), shaft and support rail units and a versatile range of accessories allow a wide spectrum of applications.

Linear guidance systems with a modular configuration facility

Possible combinations

Guideways of various designs

Track roller guidance systems

Track roller guidance systems from Schaeffler are linear guidance systems that can be configured on a modular basis for an extremely wide variety of applications. Due to their lightweight construction, they are highly suitable for use in handling systems. They are characterised in particular by quiet running, high traverse velocities, long travel distances and the modular concept.

Track roller guidance systems comprise one or more carriages made from aluminium, profiled track rollers and a straight or curved guideway ► 1772 | 8. The carriages are available as hollow section carriages, open carriages, compact carriages and bogie carriages for curved, oval and circular guidance systems.

The guideways are made from aluminium with rolled-in raceway shafts made from rolling bearing steel. The guideways are available in numerous different designs, including a solid profile guideway, hollow section guideway, flat guideway, guideway with slot etc. They are selected as appropriate to the intended purpose of the track roller guidance system.



Track roller guidance systems LF

F_y, F_z = load-bearing component in y and z direction

M_x, M_y, M_z = moment about x, y and z axis

- ① Guideway with hollow section profile
- ② Profiled track roller
- ③ Hollow section carriage

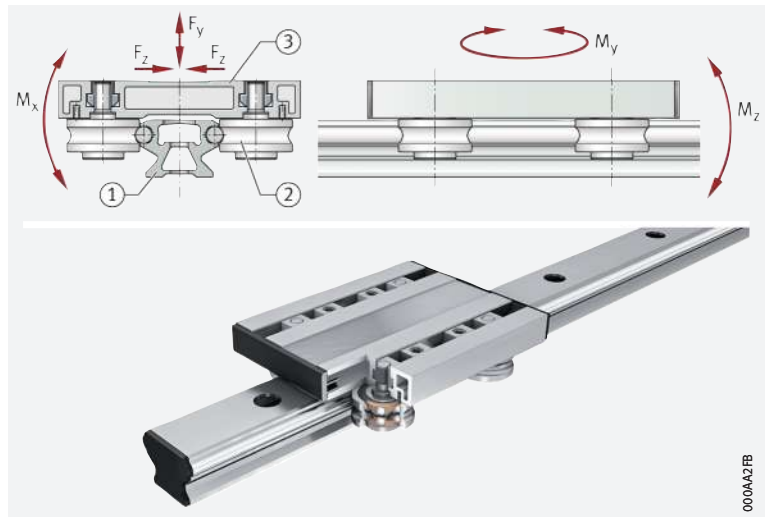

The standard range is described in detail in the catalogue Track Roller Guidance Systems ► 1772 | 8, in the catalogue Shaft Guidance Systems ► 1773 | 9 and in the online version **medias professional** ► <https://medias.schaeffler.com>.

4.4

Flat cage and recirculating roller guidance systems

Flat cage guidance systems

Where linear locating or non-locating bearings with extremely high load carrying capacity, very smooth running and low, uniform friction are required for limited stroke lengths, for example, flat cage guidance systems are used ► 1773 | 9. These guidance systems comprise a guideway arrangement separated by needle or cylindrical roller flat cages. The guidance systems have particularly high rigidity, high accuracy and low friction and require significantly less space than other linear guidance systems.

9

Flat cage guidance systems M/V,
ML/V, MVZ, J/S

F_y, F_z = load directions

- ① M/V guideways
- ② J/S guideways
- ③ Angled needle roller flat cage
- ④ Needle roller flat cage

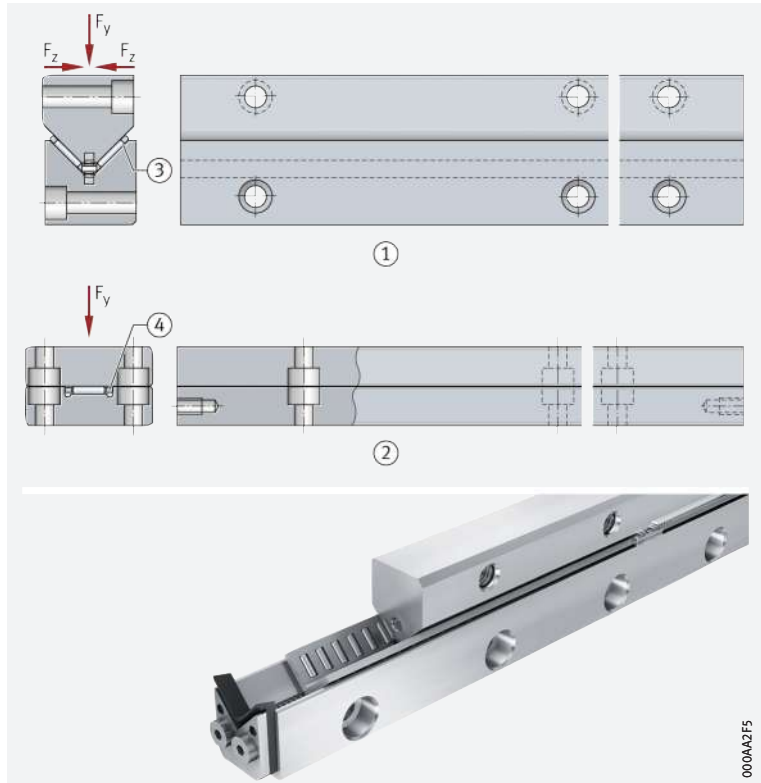

Linear recirculating roller guidance systems

Linear recirculating roller guidance systems comprise a bearing arrangement system for linear motion with unlimited stroke ▶ 1773 | 10. Since the guidance elements have a versatile range of possible arrangements, linear recirculating roller guidance systems are suitable for numerous applications in general machine building, especially for linear guidance systems in machine tools where high guidance and positioning accuracies are required over long traverse distances.

10

Linear recirculating roller
guidance systems RUS, RUS.-KS,
PR, RUSW

- ① Carriage
- ② Rolling element
- ③ Return of rolling elements
- ④ Rolling element in load zone
- ⑤ Guideway

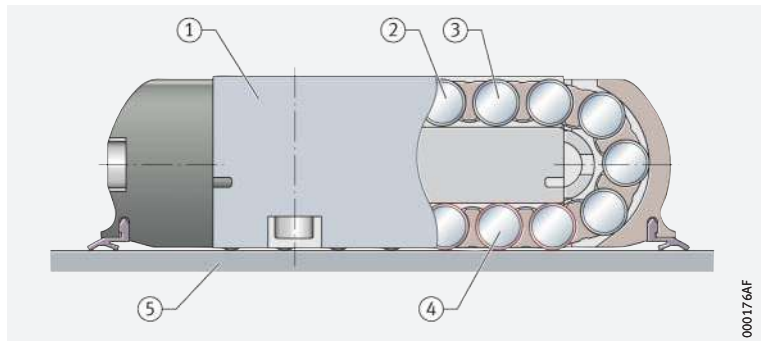

The range of recirculating guidance systems is complemented by:

- adjusting gibs for precise setting of preload
- setting devices for measuring the deformation of the adjacent construction where preload forces must be supported
- adapters for the easy mounting of linear recirculating roller bearings in a 45° arrangement.



The standard range is described in detail in the catalogue Flat Cage Guidance Systems and Linear Recirculating Roller Guidance Systems

▶ □ FR 1 and in the online version **medias professional**

▶ <https://medias.schaeffler.com>.

4.5 Miniature guidance systems

Features Miniature guidance systems from Schaeffler are not standard linear guidance systems that have simply been reduced in size, but were specially developed for very small design envelopes. Due to their compact design, they can often be used to replace bearing arrangements that require significantly more space. The guidance systems are preloaded linear locating bearings for limited and unlimited stroke lengths.

Two-row miniature linear recirculating ball bearing and guideway assemblies

Modular concept These units have moderate load carrying capacity and moderate to high moment load carrying capacity. Due to their modular concept, guideways and carriages can be interchanged within each interchangeability and accuracy class. This simplifies the fitting of guidance systems, gives easier spare parts purchasing and allows very economical stock-holding. The saddle plates and guideways are corrosion-resistant. Seals on the end faces of the carriages protect the rolling element system against contamination. The carriages are greased and can be relubricated. The guideways and carriages are also available in a wide version
▶ 1774 | 11.

11
Two-row miniature linear recirculating ball bearing and guideway assemblies KWEM, TKDM

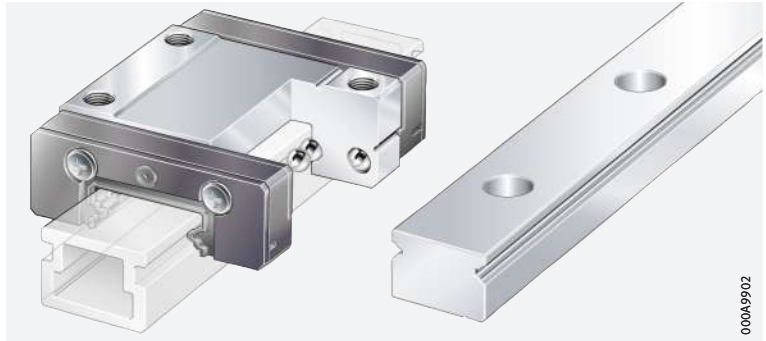

Information on the units is given in the Technical Product Information Corrosion-resistant Miniature Linear Recirculating Ball Bearing and Guideway Assemblies ▶ 163 as well as the online version *medias professional* ▶ <https://medias.schaeffler.com>.

Four-row miniature linear recirculating ball bearing and guideway assemblies

Four-row miniature linear recirculating ball bearing and guideway assemblies are ready-to-fit guidance systems for unlimited stroke lengths ▶ 1774 | 12. They have high to very high load carrying capacity and rigidity. Due to the lubricant reservoir, the relubrication intervals can be extended. The saddle plates and guideways are corrosion-resistant. Seals on the end faces of the carriages protect the rolling element system against contamination. The carriages are greased and can be relubricated.

12
Four-row miniature linear recirculating ball bearing and guideway assemblies KUME...-C

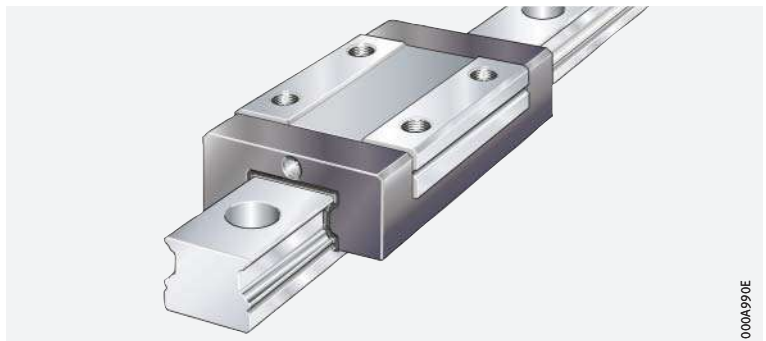



Information on the units is given in the Technical Product Information Corrosion-resistant Miniature Linear Recirculating Ball Bearing and Guideway Assemblies ► □ TPI 163 as well as the online version **medias professional** ► <https://medias.schaeffler.com>.

Miniature carriage units

Miniature carriage units with cylindrical roller flat cages are corrosion-resistant, ready-to-fit cage guidance systems for limited stroke lengths ► 1775 | □ 13. They have a high load carrying capacity, high rigidity and high accuracy whilst requiring very little space.

□ 13
Miniature carriage
units RMWE...VA

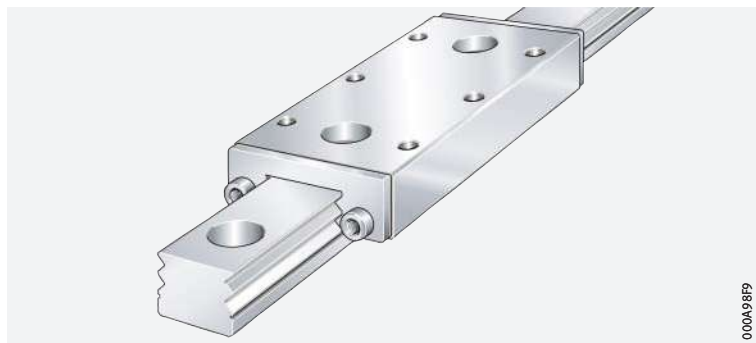

000498F9



Information on the units is given in the Technical Product Information Corrosion-resistant Miniature Carriage Units ► □ TPI 160 as well as the online version **medias professional** ► <https://medias.schaeffler.com>.

4.6 Screw drives

Ball screw, roller screw and planetary screw drives

For a wide range of application areas in machine building and automotive engineering, as well as in handling and automation technology, Schaeffler offers a comprehensive portfolio of ball screw, roller screw and planetary screw drives ► 1775 | □ 14.

□ 14
Screw drives

- ① Ball screw drive KGT
- ② Roller screw drive RGT
- ③ Planetary screw drive PWG



000481F5A

The function of screw drives

Screw drives comprise a threaded spindle and a threaded nut. Due to the rotation of the spindle, the nut moves in a translational manner on the spindle and thus converts the rotational motion of the drive into translational motion. It is rigidly connected to the adjacent construction and gives axial displacement or positioning of the component. The main load direction of screw drives is axial, radial load is not permissible. The screw drive can be subjected to high dynamic axial load.



Information on the Schaeffler screw drive range is given in the Product Data Sheet ►  *PDB 35*.

Ball screw drives

In ball screw drives KGT, the load is transmitted from the spindle by means of balls to the nut. The nut (cylindrical nut or flanged nut) has a return system for recirculating the rolling elements.

Characteristics

Ball screw drives are characterised by:

- high load carrying capacity due to the large number of balls
- quiet, uniform running
- reliable function and operational security due to the internal return and recirculation system
- easy-to-fit nut design
- sealed nuts (optional).

Roller screw screws

In roller screw drives RGT, force is transmitted via the thread flanks of the rollers. Since the number of contact surfaces here is significantly higher than in ball screw drives, roller screw drives have significantly higher load carrying capacity. Roller screw drives have significantly smaller pitch values than ball screw drives. Since there is no recirculation of balls, in contrast to KGT, very quiet running is achieved. In the case of preloaded double threaded nuts, the load carrying capacity is lower due to the load-bearing length of the threaded rollers – smaller pitch – than for single preloaded nuts.

Design of roller screw drives

Roller screw drives comprise, as in the case of ball screw drives, a threaded spindle and a threaded nut. However, the threaded nut contains threaded rollers arranged parallel to the axis. As the threaded spindle rotates, the threaded rollers rotate in planetary motion about the threaded spindle without axial displacement. The rotational motion of the nut and planets is synchronised by means of gear rings in order to prevent axial displacement. As a result, a high positional accuracy is achieved. Schaeffler roller screw drives are available, in various series and with corresponding bearing components, as ready-to-fit units. Roller screw drives differ essentially in terms of the threaded nut design.

Characteristics

Roller screw drives are characterised by:

- high axial load carrying capacity
- high axial rigidity
- small thread pitch values
- low running noise
- simple mounting and dismantling of the spindle nut
- high operational security
- high positional accuracy.

Areas of application

Due to their high rigidity and axial load carrying capacity, roller screw drives are used particularly in high precision machine tools, measuring machinery and industrial robots as well as in electronic component manufacture and precision engineering.

Planetary screw drives

Planetary screw drives PWG are characterised by a very high performance density. In these planetary screw drives, force is transmitted via the flanks of the rollers, spindle and nut ► 1777 | 15. Due to the large number of contact points, a very high axial load carrying capacity is achieved. Due to the very small pitch values, high axial operating forces can be achieved with small drive units (without a gearbox).

15
Planetary screw drive PWG,
exploded view



Structure Planetary screw drives PWG comprise a threaded spindle and cylindrical nut or flanged nut. The cylindrical nut and flanged nut differ only in the method by which they are fixed to the table.

The nut contains planets arranged parallel to the axis. The planets roll uniformly on the threaded spindle and the nut. Planetary screw drives are designed for temperatures between -10 °C and $+80\text{ °C}$.

Characteristics Advantages of planetary screw drives:

- very economical drive
- very high load carrying capacity due to the large number of rolling contacts
- high axial rigidity
- preloaded clearance-free
- very small pitch values ($< 1\text{ mm}$)
- very quiet running (no rotating rolling elements)
- simple, robust design
- very high performance density
- high reliability and operational security.



Detailed information on planetary screw drives is given in the Technical Product Information Planetary Screw Drives ► TPI 254.

4.7 Driven linear units

Features Rapid progress in the automation of production and assembly processes has pushed forward the development of complete, driven assemblies. These comprise a high precision guidance system, a rigid support rail, a wear-free servomotor drive and a user-friendly control system.

Linear actuators

Linear actuators from Schaeffler are integral modular systems containing all the components required for operation. The linear actuators are guided by linear recirculating ball bearing and guideway assemblies of series KUVE or by track roller guidance systems LF. The drive function is carried out by a ball screw drive, direct drive or toothed belt ▶ 1778 | 16 to ▶ 1778 | 18.

16

Linear actuators with linear recirculating ball bearing and guideway assemblies and toothed belt drive

MKU..-ZR

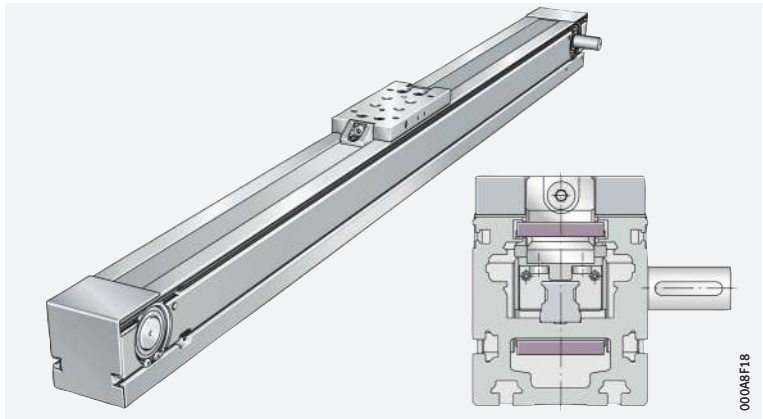

17

Linear actuators with linear recirculating ball bearing and guideway assemblies and ball screw drive

MKU..-KGT

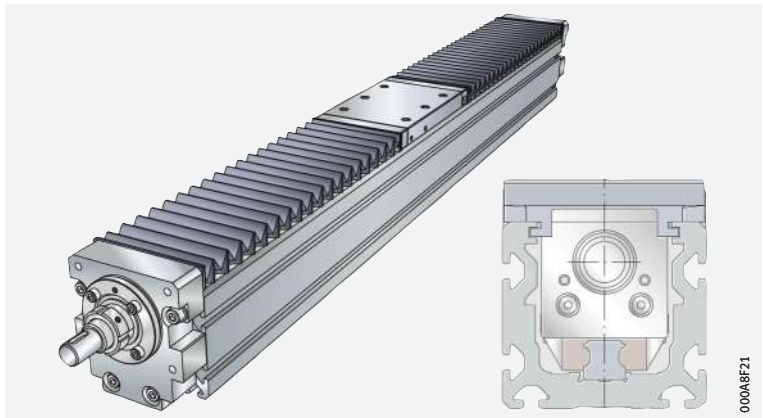

18

Linear actuators with linear recirculating ball bearing and guideway assemblies and ball screw drive

MKUVS32-KGT

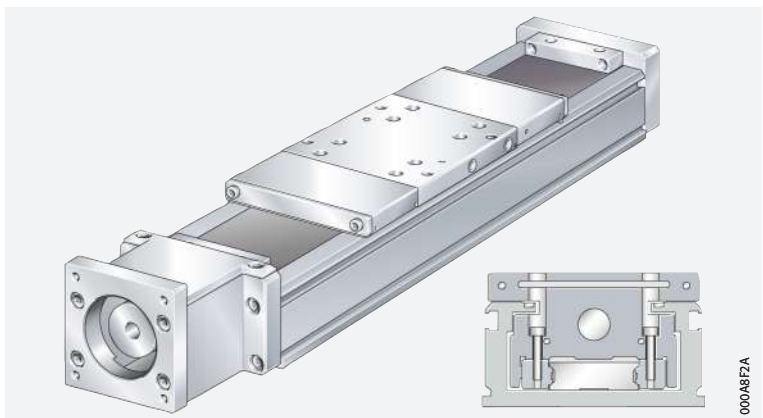

Linear tables

Linear tables from Schaeffler are used where larger masses are moved in one or more axes. Due to the large distances between support points, linear tables are also capable of supporting high torques. The guidance systems used are linear ball bearings or linear recirculating ball bearing and guideway assemblies.

Linear tables are available without a drive mechanism, with a ball screw drive, with a trapezoidal lead screw drive or a direct drive ► 1779 | ☐ 19 and ► 1779 | ☐ 20. They are available with an open or closed shaft guidance system.

☐ 19
Linear tables
without drive

LT

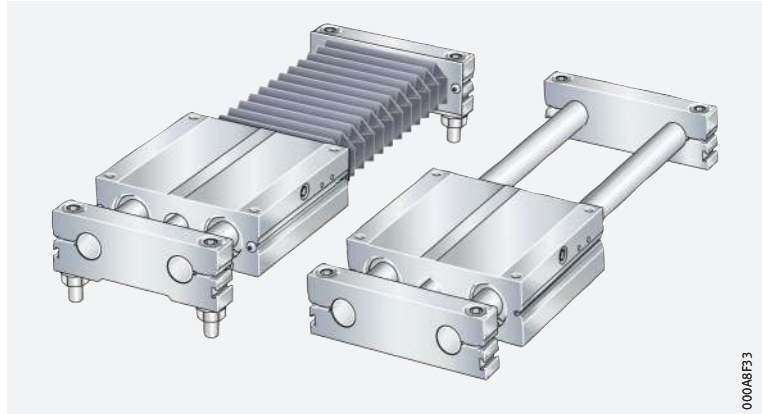

☐ 20
Linear tables
with trapezoidal lead screw drive

LT

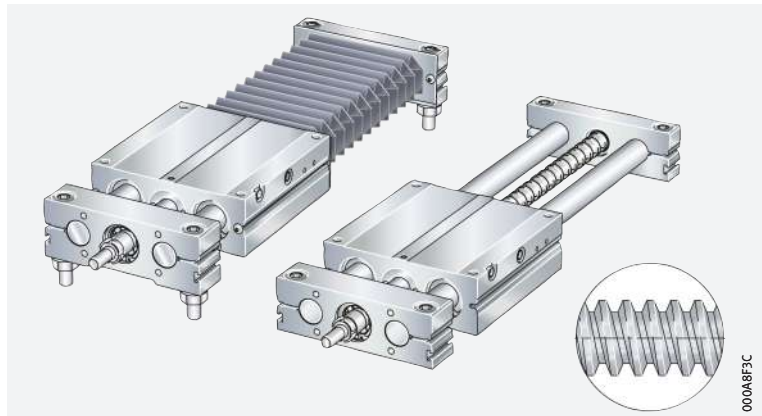

The INA range of driven linear units is complemented by suitable controllers, motors and gearboxes which are optimally matched to each other.



Detailed information on these units is given in the catalogue Driven Linear Units ► ☐ AL 1.

5 Spherical plain bearings, rod ends

5.1 Spherical plain bearings, maintenance-free

-  **Features** Maintenance-free spherical plain bearings are used where:
- there are particular requirements for operating life under maintenance-free operation
 - for reasons of lubrication, bearings with a metallic sliding contact surface are not suitable, for example under unilateral load.

Spherical plain bearings allow spatial adjustment movements and, depending on the bearing type, are preferably used to support radial, combined or axial loads.



The complete range is described in the catalogue Plain Bearings ►  HG 1 and in the online version **medias professional** ► <https://medias.schaeffler.com>.

Sliding layers

Maintenance-free spherical plain bearings have special sliding layers based on PTFE (polytetrafluoroethylene). In terms of performance capability, these are:

- ELGOGLIDE, the highest performance sliding layer
- ELGOGLIDE-W11, the sliding layer for low contact pressures and minimal friction
- PTFE-bronze film
- PTFE composite material.

These materials form the slideway of the outer ring or the housing locating washer. They transmit the forces occurring and perform the lubrication function. Maintenance-free bearings must not be lubricated.

ELGOGLIDE

The sliding layer comprises a 0,5 mm thick layer of ELGOGLIDE, is embedded in synthetic resin and is attached by a high strength bond to the support body. The flow behaviour of the sliding layer is, in conjunction with the support body, almost negligible even under very high load. The adhesive bond is resistant to moisture and swelling.

ELGOGLIDE is a registered trademark and product of Schaeffler.

-  **ELGOGLIDE designs** For differing requirements, the following are available:

- ELGOGLIDE the standard material for very high dynamic contact pressures from 25 N/mm² to 300 N/mm² and a long operating life
- ELGOGLIDE-W11 the material for dynamic contact pressures from 1 N/mm² to 100 N/mm² and with low coefficients of friction even at low contact pressures.

-  **PTFE-bronze film** The PTFE-bronze film (metal lattice material) is fixed to the outer ring curved surface. The metal lattice is made from high strength bronze and acts as a stabiliser for the sintered PTFE composite material.

-  **PTFE composite material** The PTFE composite material comprises sheet steel with bronze attached by sintering and an embedded plastic composite material made from PTFE. The composite material is embedded with form contact between the inner ring curved surface and the outer steel surface.

Radial spherical plain bearings, radial large spherical plain bearings

Radial spherical plain bearings comprise inner and outer rings with maintenance-free sliding layers made from ELGOGLIDE, PTFE composite material or PTFE-bronze film.

Sealed spherical plain bearings are protected by lip seals against contamination and water spray. These bearings have the suffix 2RS, 2TS or 2RS2.

**Radial spherical plain bearings, maintenance-free**

- ① Sliding contact surface hard chromium/PTFE composite material, open: GE..-UK
- ② Sliding contact surface hard chromium/PTFE composite material, open: GE..-FW
- ③ Sliding contact surface hard chromium/ELGOGLIDE, with lip seal: GE..-UK-2RS
- ④ Sliding contact surface hard chromium/ELGOGLIDE, with high performance seal: GE..-UK-2TS
- ⑤ Sliding contact surface steel/PTFE-bronze film, open: GE..-PW



000A813D

**Radial large spherical plain bearings, maintenance-free, X-life design**

- ① Sliding contact surface hard chromium/ELGOGLIDE, open: GE..-DW
- ② Sliding contact surface hard chromium/ELGOGLIDE, with lip seal: GE..-DW-2RS2



000A8146



Radial large spherical plain bearings from $d = 320$ mm are X-life bearings.

1
Series and design

Series	Sliding layer	DIN ISO	Dimension series	Shaft d mm	
				from	to
GE...UK-2RS	ELGOGLIDE	12240-1	E	17	300
GE...UK-2TS	ELGOGLIDE	12240-1	E	30	300
GE...FW-2RS	ELGOGLIDE	12240-1	G	25	280
GE...FW-2TS	ELGOGLIDE	12240-1	G	25	280
GE...DW	ELGOGLIDE (X-life)	12240-1	C	320	1000
GE...DW-2RS2	ELGOGLIDE (X-life)	12240-1	C	320	1000
GE...UK	PTFE composite material	12240-1	E	6	30
GE...FW	PTFE composite material	12240-1	G	6	25
GE...PW	PTFE-bronze film	12240-1	K	6	30

Angular contact spherical plain bearings

Angular contact spherical plain bearings comprise inner and outer rings with ELGOGLIDE. In addition to radial forces, they can also support axial forces and are suitable for alternating dynamic loads.

3
Angular contact spherical plain bearing, maintenance-free

① Sliding contact surface hard chromium/ELGOGLIDE, open: GE...SW



2
Series and design

Series	Sliding layer	DIN ISO	Shaft d mm	
			from	to
GE...SW	ELGOGLIDE	12240-2	25	200

Axial spherical plain bearings, axial large spherical plain bearings

Axial spherical plain bearings comprise shaft locating and housing locating washers with ELGOGLIDE. They are preferably used to support axial forces and are suitable as support or base bearings.

4
Axial spherical plain bearing, maintenance-free

① Sliding contact surface hard chromium/ELGOGLIDE, open: GE...AW



X-life



Series and design
Axial large spherical plain bearings from $d = 220$ mm are X-life bearings.

Series	Sliding layer	DIN ISO	Shaft d mm	
			from	to
GE..-AW	ELGOGLIDE	12240-3	10	360

5.2 Spherical plain bearings, requiring maintenance

Radial spherical plain bearings

Radial spherical plain bearings comprise inner and outer rings with steel/steel or steel/bronze sliding contact surfaces and are lubricated via the inner and outer ring. They can support radial forces, transmit motion and loads with low moment levels and thus keep bending stresses away from the construction elements.



Radial spherical plain bearings,
requiring maintenance

- ① Sliding contact surface steel/steel, metric or inch sizes, open: GE..-DO, GE..-ZO
- ② Sliding contact surface steel/steel, open: GE..-FO
- ③ Sliding contact surface steel/steel, cylindrical extensions on inner ring, open: GE..-LO
- ④ Sliding contact surface steel/bronze, open: GE..-PB
- ⑤ Sliding contact surface steel/steel, with lip seal or high performance seal: GE..-DO-2RS, GE..-DO-2TS
- ⑥ Sliding contact surface steel/steel, with lip seal or high performance seal: GE..-FO-2RS, GE..-FO-2TS
- ⑦ Sliding contact surface steel/steel, cylindrical extensions on inner ring, with lip seal: GE..-HO-2RS
- ⑧ Radial large spherical plain bearing, sliding contact surface steel/steel, with lip seal: GE..-DO-2RS4



000A8161



The bearings are particularly suitable for alternating loads with impact and shock type stresses and support axial loads in both directions. Sealed spherical plain bearings are protected against contamination and water spray by lip seals and have the suffix 2RS, 2TS or 2RS4.

 4
 Series and design

Series ¹⁾	Sliding layer	DIN ISO	Dimension series	Shaft d mm	
				from	to
GE...DO	Steel/steel	12240-1	E	6	300
			C	320	1000
GE...DO-2RS			E	17	300
GE...DO-2TS			E	30	140
GE...DO-2RS4			C	320	1000
GE...HO		-	-	20	120
GE...HO-2RS		-	-	20	120
GE...FO		12240-1	G	6	280
GE...FO-2RS	G		15	280	
GE...FO-2TS	G		25	120	
GE...LO	W		12	320	
GE...PB	Steel/bronze		K	6	30

¹⁾ Radial spherical plain bearings GE...ZO are available in inch sizes and with a shaft diameter from 0,75 inch to 5 inch.

Angular contact spherical plain bearings

Angular contact spherical plain bearings GE...SX correspond to DIN ISO 12240-2. They have inner rings with a curved outer slideway and outer rings with a concave inner slideway, where a steel/steel sliding contact surface is present. The bearings are available for shaft diameters from 25 mm to 200 mm. Other sizes are available by agreement.

 6
 Angular contact spherical plain bearing, requiring maintenance

① Sliding contact surface steel/steel, open: GE...SX



Angular contact spherical plain bearings can support axial forces as well as radial forces. As a result, they are suitable for alternating dynamic loads.

They transmit motion and loads with low moment levels, keep bending stresses away from the adjacent structure and are lubricated with grease via the outer ring.

Axial spherical plain bearings

Axial spherical plain bearings GE...AX correspond to DIN ISO 12240-3. In these units, the shaft locating washer is supported in the ball socket-shaped sliding zone of the housing locating washer, where a steel/steel sliding contact surface is present. The bearings are available for shaft diameters from 10 mm to 200 mm. Other sizes are available by agreement.

7 Axial spherical plain bearing, requiring maintenance

- ① Sliding contact surface steel/steel, open: GE..-AX

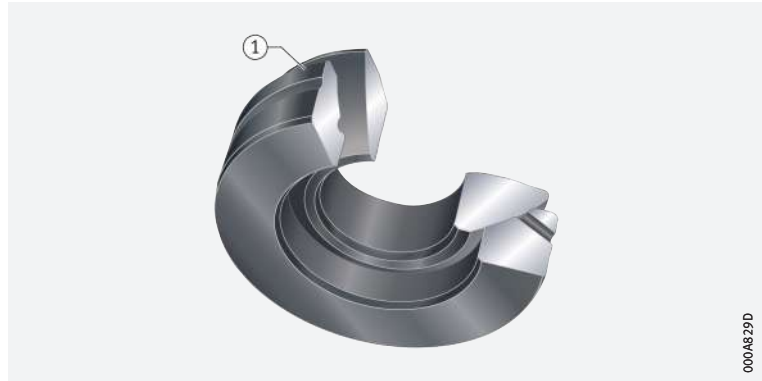

The bearings can support axial forces and transmit support forces with low moment levels into the adjacent construction. In order to support radial forces, they can be combined with radial spherical plain bearings of dimension series E in accordance with DIN ISO 12240-1. The bearings are lubricated via the housing locating washer.

5.3 Rod ends, maintenance-free

Features

Maintenance-free rod ends and maintenance-free corrosion-resistant rod ends comprise a housing with integral shank and a maintenance-free spherical plain bearing. The shank has an internal or external thread, the spherical plain bearing is firmly seated and located in the housing.

Depending on their type, the rod ends are available either open or sealed on both sides. The rod ends are protected against corrosion by a zinc coating.

The sliding layer between the inner ring and outer ring is PTFE composite material, ELGOGLIDE or PTFE-bronze film.

Area of application

Maintenance-free rod ends can support radial loads in a tensile or compressive direction. They are particularly suitable for slow movements with small to moderate swivel angles and unilateral loads. For alternating loads, rod ends with bearings of series GE..-UK-2RS(-2TS) and GE..-FW-2RS(-2TS) can be used.

Dimension series E

Rod ends to DIN ISO 12240-4, dimension series E, incorporate radial spherical plain bearings GE..-UK or GE..-UK-2RS(-2TS) and a right or left hand internal or external thread ▶ 1785 | 8. The sliding contact surfaces are hard chromium/PTFE composite material or hard chromium/ELGOGLIDE. The thin walled design of the eye housing allows compact adjacent constructions.

These rod ends are also available by agreement with radial spherical plain bearings GE..-FW or GE..-FW-2RS(-2TS) of dimension series G.

8 Rod ends, maintenance-free, dimension series E

- ① With internal thread
② With external thread



Dimension series K

Rod ends to DIN ISO 12240-4, dimension series K, incorporate radial spherical plain bearings GE..-PW and a right or left hand internal or external thread ▶ 1786 | 9. The sliding contact surface is steel/PTFE-bronze film.

 9
Rod ends, maintenance-free,
dimension series K

- ① With internal thread
- ② With external thread

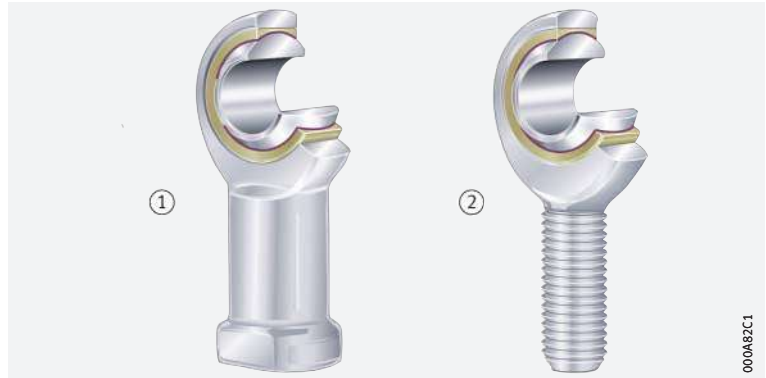

Corrosion-resistant rod ends

Corrosion-resistant rod ends to DIN ISO 12240-4, dimension series K, incorporate radial spherical plain bearings GE..-PS and a right or left hand internal or external thread ▶ 1786 | 10. The sliding contact surface comprises corrosion-resistant steel and corrosion-resistant PTFE-bronze film which is attached to the curved outer ring surface.

The shank has a thread to DIN 13 and the diameter range extends from 5 mm to 30 mm. The bore tolerance of the spherical plain bearings is H7 ⑥.

Corrosion-resistant rod ends with an internal thread are also available with CETOP mounting dimensions to ISO 8139 for pneumatic cylinders. These are used in preference in control and automation engineering.

 10
Corrosion-resistant rod ends,
maintenance-free,
dimension series K

- ① With internal thread
- ② With external thread



Series, sliding layer, standard

Maintenance-free rod ends are designed, according to their specific series, with different sliding layers ➤ 1787 | 5 and ➤ 1787 | 6.

 **5**
Series and design for sliding layer
ELGOGLIDE or PTFE composite
material

Series	Thread	DIN ISO	Dimension series	Shaft d mm	
				from	to
GIR...UK	Internal, right hand	12240-4	E, type F	6	30
GIR...UK-2RS				17	80
GIR...UK-2TS				30	80
GIL...UK	Internal, left hand			6	30
GIL...UK-2RS				17	80
GIL...UK-2TS				30	80
GAR...UK	External, right hand	12240-4	E, type M	6	30
GAR...UK-2RS				17	80
GAR...UK-2TS				30	80
GAL...UK	External, left hand			6	30
GAL...UK-2RS				17	80
GAL...UK-2TS				30	80

 **6**
Series and design for sliding layer
PTFE-bronze film

Series	Thread	DIN ISO	Dimension series	Shaft d mm			
				from	to		
GIKR...PW	Internal, right hand	12240-4	K, type F	6	30		
GIKSR...PS				5	30		
GIKPR...PW	Internal, right hand, fine pitch thread for standard pneumatic cylinders to DIN ISO 15552			12240-4	K, type M	6	30
GIKPSR...PS						5	30
GIL...PW	Internal, left hand					6	30
GIKSL...PS						5	30
GAKR...PW	External, right hand	12240-4	K, type M			6	30
GAKSR...PS						5	30
GAKL...PW	External, left hand			6	30		
GAKSL...PS				5	30		

5.4 Rod ends, requiring maintenance

Rod ends requiring maintenance comprise a housing with integral shank and a spherical plain bearing requiring maintenance. The shank has an internal or external thread, the spherical plain bearing is firmly seated and located in the housing.

Depending on their type, the rod ends are available either open or sealed on both sides. The rod ends are protected against corrosion by a zinc coating.

Area of application

Rod ends requiring maintenance can support radial forces in a tensile or compressive direction and can transmit motions and forces with low moment levels. They are particularly suitable for alternating radial loads and, in certain circumstances, for unilateral loads. The thin walled design of the eye housing allows compact adjacent constructions.

Dimension series E

Rod ends to DIN ISO 12240-4, dimension series E, incorporate radial spherical plain bearings GE...DO or GE...DO-2RS(-2TS) and a right or left hand internal or external thread. The sliding contact surface is formed by steel inner and outer rings ▶ 1788 | 11. They can be relubricated (with the exception of series d = 6 mm to d = 12 mm) via the lubrication nipple or the housing bore.



11
Rod ends requiring maintenance,
dimension series E,
sliding contact surface steel/steel

- ① With internal thread
- ② With external thread



Dimension series K

Rod ends to DIN ISO 12240-4, dimension series K, incorporate radial spherical plain bearings GE...PB and a right or left hand internal or external thread. The sliding contact surface is formed by steel inner rings and bronze outer rings ▶ 1788 | 12. They can be relubricated via funnel type lubrication nipples in accordance with DIN 3405 in the eye housing.



12
Rod ends requiring maintenance,
dimension series K,
sliding contact surface
steel/bronze

- ① With internal thread
- ② With external thread

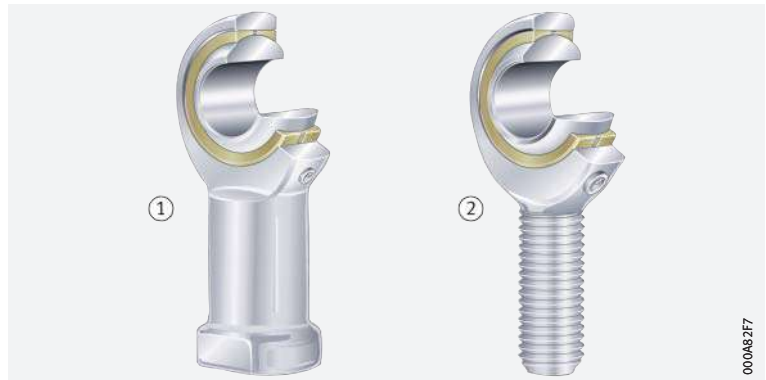



Sealing

Sealed rod ends have the suffix 2RS or 2TS. They are protected by lip seals on both sides against contaminants and water spray.

Rod ends GIR...DO-2TS, GIL...DO-2TS, GAR...DO-2TS and GAL...DO-2TS are sealed on both sides by means of integrated, triple lip high performance seals. Rod ends of dimension series K are not sealed.

Series, sliding contact surface, standard

Rod ends requiring maintenance are designed, according to their specific series, with different sliding contact surfaces ► 1789 |  7.

 7
Series and design

Series	Sliding contact surface	Thread	DIN ISO	Dimension series	Shaft d mm			
					from	to		
GIR...DO	Steel/ steel	Internal, right hand	12240-4	E, type F	6	30		
GIR...DO-2RS					17	80		
GIR...DO-2TS					30	80		
GIL...DO		Internal, left hand			6	30		
GIL...DO-2RS					17	80		
GIL...DO-2TS					30	80		
GAR...DO		External, right hand		External, right hand	E, type M	6	30	
GAR...DO-2RS						17	80	
GAR...DO-2TS						30	80	
GAL...DO						External, left hand	6	30
GAL...DO-2RS							17	80
GAL...DO-2TS							30	80
GIKR...PB	Steel/ bronze	Internal, right hand	12240-4	K, type F	6	30		
GIKL...PB		Internal, left hand						
GAKR...PB		External, right hand		K, type M				
GAKL...PB		External, left hand						

5.5 Hydraulic rod ends, requiring maintenance

Features

Hydraulic rod ends are fitted with radial spherical plain bearings GE...LO or GE...DO. They have steel/steel sliding contact surfaces, can support radial forces in a tensile or compressive direction, transmit movements and forces at low moment levels and are suitable for alternating loads. The rod ends can be screw mounted using a thread in the shank or welded in place by means of circular or rectangular welding faces.

Rod ends with a circular welding face have a 45° welding chamfer and a centring facility by means of a concentric locating pin.

They are particularly suitable for piston rods. Hydraulic rod ends with a rectangular cross-section are particularly suitable for cylinder bases.

The rod ends are slotted on both sides up to $d \leq 50$ mm and on one side from $d > 50$ mm; they can be relubricated via taper type lubrication nipples.

Hydraulic rod ends with thread clamping device

Rod ends GIHNRK..-LO conform to DIN 24338, ISO 6982 for standard hydraulic cylinders in accordance with CETOP recommendation RP 58 H and to DIN 24333, DIN 24336, DIN ISO 6020-1 and DIN ISO 6022.

The spherical plain bearings are located in the rod end by means of retaining rings. The thread clamping device comprises two hexagonal socket head screws to DIN EN ISO 4762.

Rod ends GIHRK..-DO are particularly suitable for hydraulic cylinders. They have very small linkage distances with maximum stroke utilisation. These rod ends are also available with maintenance-free spherical plain bearings GE..-UK-2RS(-2TS) and GE..-FW-2RS(-2TS).

 **8**
Series, thread type, standard

Series	Thread	DIN ISO	Shaft d mm	
			from	to
GIHNRK..-LO	Right hand	6982	12	250
GIHRK..-DO	Right hand	–	20	120

Features

Hydraulic rod ends with welding face

Rod ends GK..-DO are designed to DIN ISO 12240-4, dimension series E, type S, with a circular welding face, a centring pin on the shank base and a 45° welding chamfer. They are suitable for fixing to piston rod ends and cylinder bases.

The spherical plain bearings are located in the housing by staking on both sides.

Rod ends GF..-DO are available in a heavy-duty design with a rectangular welding face. The spherical plain bearings are located in the housing by retaining rings and can be dismantled. These rod ends are suitable for fixing to hydraulic cylinder bases.



By agreement, hydraulic rod ends GF and GK are also available with radial spherical plain bearings GE..-UK-2RS (-2TS) or alternatively with GE..-FW-2RS (-2TS).

 **9**
Series, thread type, standard

Series	Welding face	DIN ISO 12240-4	Shaft d mm	
			from	to
GK..-DO	Circular	Dimension series E, type S	10	80
GF..-DO	Rectangular	–	20	120

6 Composite plain bearings with plain bushes

 **Product range** Schaeffler supplies plain bushes and metal/polymer composite plain bearings for diverse requirements ► 1800 | 9.

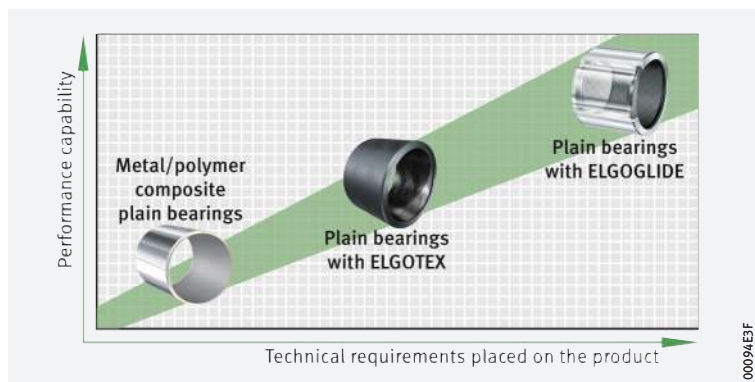

6.1 Metal/polymer composite plain bearings

General features

These plain bearings are suitable for very small radial or axial design envelopes. They are available as bushes, flanged bushes, thrust washers and strips. The bushes are available in metric sizes and in inch sizes.

The bushes and flanged bushes are rolled from a cut section of strip and have a butt joint over the entire width of the bearing.

The plain bearings are supplied with either steel backing or bronze backing. Bearings with a bronze backing have high corrosion resistance and very good thermal conductivity and are antimagnetic.



There are different materials for metal/polymer composite plain bearings, the maintenance-free E40 and E40-B or the low-maintenance E50.

The maintenance-free and low-maintenance materials conform to the regulations for lead-free plain bearings.

They thus fulfil the Directive 2000/53/EC (End-Of-Life Vehicles Directive) and the Directive 2011/65/EU (RoHS-II) for the restriction of hazardous substances.



Further information:

- Catalogue Plain Bearings ►  HG 1
- Metal/polymer Composite Plain Bearings ►  TPI 211
- Product selection and information system **medias professional** ► <https://medias.schaeffler.com>
- Download and ordering via ► <https://www.schaeffler.de/std/1D64>.

Plain bearings – material E40, maintenance-free

The maintenance-free plain bearing material E40 is, due to the dry lubricant PTFE, intended for dry running. These bearings are thus particularly suitable where the bearing position must be maintenance-free, there is a risk of lubricant starvation or where lubricant is unacceptable or undesirable. The material E40 can be used not only for rotary and oscillating motion but also for short stroke linear motion.

For maintenance-free metal/polymer composite plain bearings from Schaeffler, the sliding material E40 or E40-B is used. The basis of the dry lubricant is polytetrafluoroethylene PTFE with embedded chemically non-reactive additives.

The low-wear material has good sliding characteristics (no stick-slip), a low coefficient of friction and high resistance to chemicals. It does not absorb water (it is highly resistant to swelling), does not tend to weld to metal and is also suitable for hydrodynamic operation.

1
 Bushes and flanged bushes – material E40

- ① Bushes
 EGB...-E40,
 EGBZ...-E40,
 EGB...-E40-B
- ② Flanged bushes
 EGF...-E40,
 EGF...-E40-B

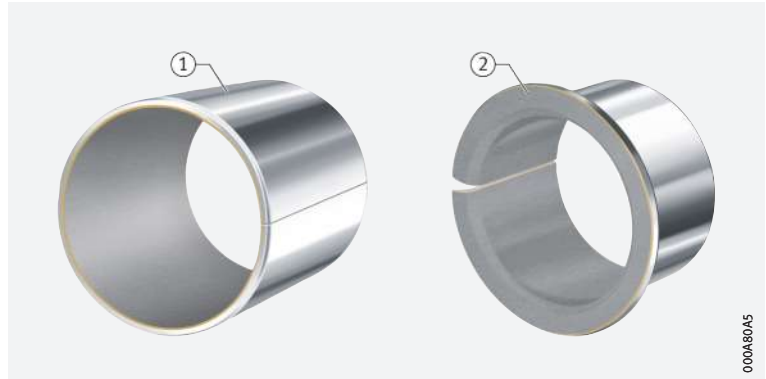

2
 Thrust washers and strips – material E40

- ① Thrust washers
 EGW...-E40,
 EGW...-E40-B
- ② Strips
 EGS...-E40
 EGS...-E40-B (available by agreement)

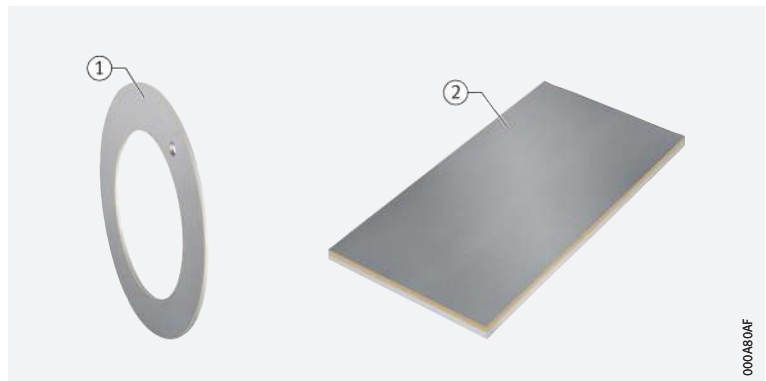

Areas of application

Typical areas of application can be found, for example, in fluid technology, in sports gear, in medical or electrical equipment as well as in automotive engineering.

Technical data

The maintenance-free plain bearing materials are available in the variants E40 and E40-B with the following mechanical and physical characteristics ► 1792 | 1.

1
 Characteristics of E40 and E40-B

Characteristic	Load		
Maximum pv value for dry running	Continuous operation	p _v	1,8 N/mm ² · m/s
	Short periods		3,6 N/mm ² · m/s
Permissible specific bearing load	Static	p _{max}	250 N/mm ²
	Rotary, oscillating		140 N/mm ²
Permissible sliding velocity	Dry running	v _{max}	2,5 m/s
	Hydrodynamic operation		>2,5 m/s
Permissible operating temperature		ϑ	-200 °C to +280 °C
Coefficient of thermal expansion	Steel backing	α _{St}	11 · 10 ⁻⁶ K ⁻¹
	Bronze backing	α _{Bz}	17 · 10 ⁻⁶ K ⁻¹
Coefficient of thermal conductivity	Steel backing	λ _{St}	>42 Wm ⁻¹ K ⁻¹
	Bronze backing	λ _{Bz}	>70 Wm ⁻¹ K ⁻¹
Relative electrical resistance after running-in		R _{rel min}	>1 Ω · cm ²

Available designs

Available standard dimension ranges for bushes, washers and strips with E40 material ▶ 1793 | 2.

 **2**
Product and size range

Plain bearings made from material E40	Designation	For shafts with the following dimensions
Bushes	EGB...-E40	3 mm to 300 mm
	EGBZ...-E40	3/16 inch to 2 inch
	EGB...-E40-B	4 mm to 100 mm
Flanged bushes	EGF...-E40	6 mm to 40 mm
	EGF...-E40-B	6 mm to 40 mm
Thrust washers	EGW...-E40	10 mm to 62 mm
	EGW...-E40-B	10 mm to 62 mm
Strips	EGS...-E40-S3E	Length 500 mm, width 260 mm, thicknesses from 1,5 mm to 3,06 mm

The plain bearings are not sealed, but can be protected against the ingress of contamination and moisture by the use of external seals.

Plain bearings – material E50, low-maintenance

For low-maintenance metal/polymer composite plain bearings from Schaeffler, the sliding material E50 is used. The basis of the sliding layer is polyoxymethylene POM.

E50 is a low-wear material with good damping characteristics and long relubrication intervals. It can be used for rotary and oscillating motion and is recommended for long-stroke linear motions. E50 is only slightly sensitive to edge loads and is insensitive to shocks.

 **3**
Bushes – material E50

- ① Bushes
EGB...-E50

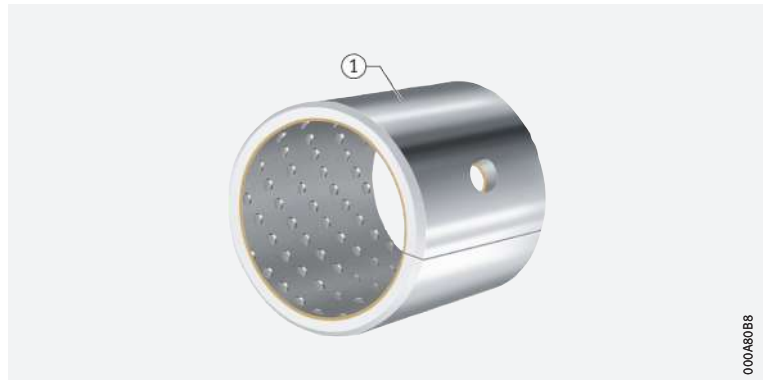

000A90B8

 **4**
Thrust washers and strips – material E50

- ① Thrust washers
EGW...-E50
- ② Strips
EGS...-E50

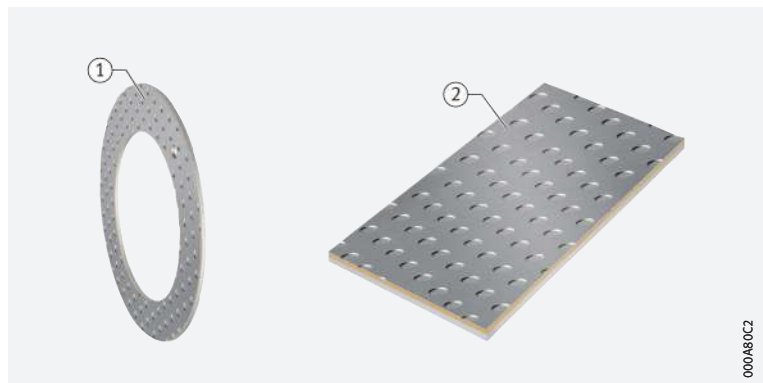

000A80C2

 **Areas of application**

Application examples can be found in particular in the area of production machinery, construction and agricultural equipment as well as commercial vehicles.

Technical data

Important mechanical and physical characteristics of the low-maintenance plain bearing material ► 1794 | 3.

 3
Characteristics of E50

Characteristics	Load		
Maximum pv value		pv	3 N/mm ² · m/s
Permissible specific bearing load	Static	p _{max}	140 N/mm ²
	Rotary, oscillating		70 N/mm ²
Permissible sliding velocity		v _{max}	2,5 m/s
Permissible operating temperature		ϑ	-40 °C to +110 °C
Coefficient of thermal expansion	Steel backing	α _{St}	11 · 10 ⁻⁶ K ⁻¹
Coefficient of thermal conductivity	Steel backing	λ _{St}	<4 Wm ⁻¹ K ⁻¹
Friction coefficient		μ	0,02 to 0,2

Available designs

Available standard dimension ranges for bushes, washers and strips with E50 material ► 1794 | 4.

 4
Product and size range

Plain bearings made from material E50	Designation	For shafts with the following dimensions
Bushes	EGB..-E50	8 mm to 100 mm
Thrust washers	EGW..-E50	12 mm to 52 mm
Strips	EGS..-E50	Length up to 500 mm, width from 80 mm to 200 mm, thickness from 0,99 mm to 2,46 mm

Special designs

In addition to the catalogue range of metal/polymer composite plain bearings, there are numerous special designs which are run in either a predominantly rotary direction or a predominantly linear direction. Schaeffler can produce further special designs by agreement.

In addition to the materials named, there are further materials such as the sliding material E60 for film bearings.

For special designs or special materials, please contact the Schaeffler engineering service.

Examples

A small selection of special designs already produced is shown below ► 1795 | 5 to ► 1795 | 7.

Special designs are possible:

- made from any plain bearing material
- with different dimensions from the catalogue products
- as combined components:
 - pressed into rings
 - with plastic moulded parts
- in different shapes:
 - bushes with windows and holes
 - bushes with stamped oil grooves
 - blanked components
 - ball cups
 - bearing shells
- with the sliding layer on the outside
- with different butt joint geometries.
- Linear plain bearings PAB comprising an outer ring with pressed-in plain bearing bushes EGB..-E50. In the design PABO, they have a segment cut out for supported shafts
- Linear plain bearing units PAGH and PAGBA comprising a housing and a pressed-in linear plain bearing PAB or PABO.

 Linear plain bearings

5

Plain bearings for swivel motion or rotation

- ① Pivoting cradle bearing
- ② Plain bush with lubrication groove and recess

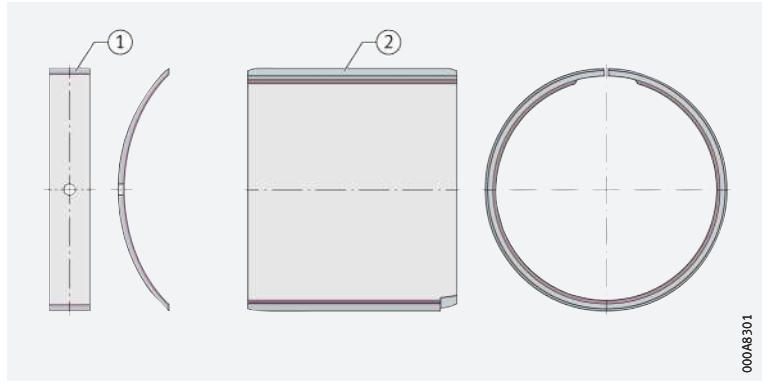

6

Ball cups

- ① Maintenance-free
- ② Low-maintenance

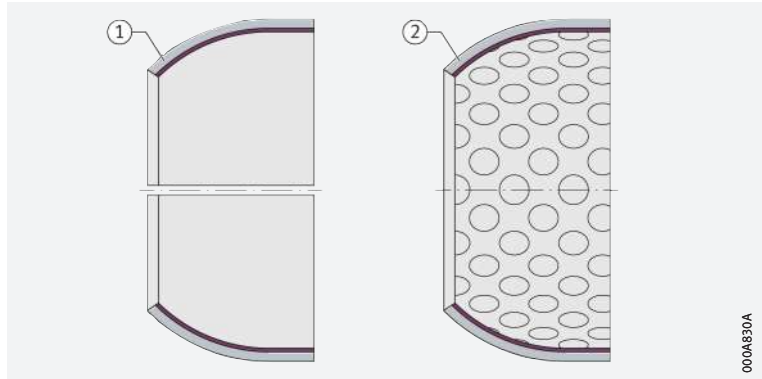

7

Linear plain bearings

- ① Linear plain bearing PAB...-PP-AS
- ② Linear plain bearing unit PAGBAO...-PP-AS

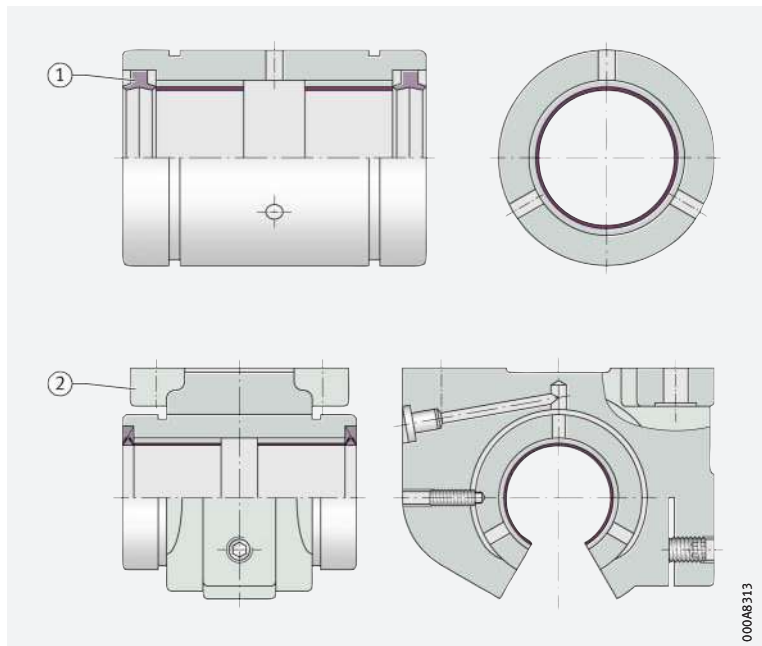

Check feasibility as early as possible

The feasibility of special designs should be checked as early as possible. This applies to the geometry and also to the costs.

Special materials

By agreement, Schaeffler can supply film bearings with the material E60. This maintenance-free special material also conforms to the stated regulations for lead-free plain bearings ► 1791.

Film bearings E60 E60 is the plain bearing material from Schaeffler for maintenance-free film bearings. The metal/polymer composite comprises a bronze rib mesh that is filled with a dry lubricant made from polytetrafluoroethylene PTFE with embedded chemically non-reactive additives.

6.2 ELGOTEX filament wound bushes, maintenance-free or water-resistant

Features The maintenance-free wound bushes ZWB made from filament composite material are non-metallic and thus resistant to numerous media. They have low mass, are resistant to shocks and vibration and have a low coefficient of friction.

In contrast to the standard design of ELGOTEX, ELGOTEX-WA is specially developed for use in water as well as salt water and sea water.



Filament wound bushes, open

- ① ELGOTEX filament wound bush, open ZWB
- ② ELGOTEX-WA filament wound bush, open ZWB..-WA



000A8103



Filament wound bushes, sealed

- ① ELGOTEX filament wound bush, sealed ZWB...-2RS
- ② ELGOTEX-WA filament wound bush, sealed ZWB...-2RS-WA



000A810C



Further information:

- Catalogue Plain Bearings > [HG 1](#)
- Plain bearings with ELGOTEX > [TPI 194](#)
- Product selection and information system **medias professional** > <https://medias.schaeffler.com>
- Download and ordering via > <https://www.schaeffler.de/std/1D64>.

Maintenance-free plain bearing material

The radial dry plain bearings have a twin layer structure > 1797 | [10](#):

- The outer layer (the backing) ensures the strength of the bush. It comprises continuous glass fibres that are additionally stabilised by means of a specific winding angle, giving an increase in strength. The fibres are bound in epoxy resin
- The inner layer (sliding layer) contains a polymer/PTFE yarn that is embedded together with fillers and solid lubricants in a resin matrix.

10

Microsection of an ELGOTEX filament wound bush

- ① Backing
- ② Sliding layer

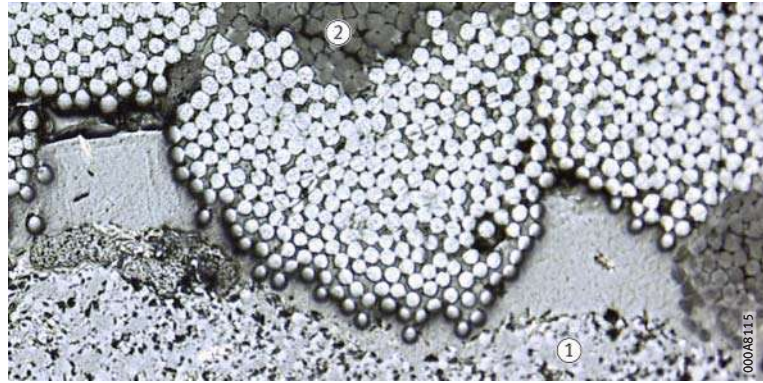

Water-resistant design ELGOTEX-WA

The specific characteristic of ELGOTEX-WA lies in the specific matching of fibre and matrix to the particular operating conditions. The inner sliding layer contains a polymer/PTFE sliding yarn that is embedded together with fillers and solid lubricants in a resin matrix. It is hydrophobic and dimensionally stable. The backing, which is reinforced by means of glass fibre, ensures the necessary strength of the bush. The thickness of the sliding layer and backing layer is specifically designed in accordance with the requirements of the application and thus of the wear limit.

Areas of application



ELGOTEX filament wound bushes are particularly suitable for use in construction machinery, conveying equipment, transportation vehicles, hydraulic applications and solar energy plant. They are also suitable as an environmentally-friendly and maintenance-free bearing type for replacing lubricated solid-section plain bearings.



ELGOTEX-WA is used in shipbuilding, marine engineering, hydromechanical steel structures, water power generation as well as in turbines and waste water treatment.

Dimension range

Available standard dimension ranges ► 1797 | 5. ELGOTEX filament wound bushes are available by agreement with integrated lip seals, on one side in design LS or on both sides in design 2RS. ELGOTEX-WA filament wound bushes have the suffix WA. ELGOTEX filament wound bushes with special dimensions up to an outside diameter $D_0 = 1\,200$ mm, special tolerance classes or in the form of segment bearings, are possible and may be available by agreement from Schaeffler.



Dimension range

ELGOTEX filament wound bush	Dimensions	
	mm	
	from	to
Inside diameter	20	200
Outside diameter	24	220
Width	15	250

Technical data for ELGOTEX

Maintenance-free ELGOTEX filament wound bushes have the following mechanical and physical characteristics ► 1798 | 6.



In underwater use, there is a considerable reduction in the rating life. In this case, the coefficient of friction may increase significantly. In the production of ELGOTEX filament wound bushes, defects (pores) and fraying may occur in the PTFE due to the production process. These cannot be prevented by technological measures and do not represent any impairment of the function.

6
 Characteristics of ELGOTEX

- 1) Bearing load as a function of velocity ► 1798 | 11.
 2) For static loads $\geq 180 \text{ N/mm}^2$, the design of ELGOTEX filament wound bushes must be checked by the Schaeffler engineering service. For values at or above this load range, we alternatively recommend ELGOGLIDE plain bushes ► 1798 | 6.3.

Characteristics		Load	
+++ = very good + = adequate			
Maximum pv value ¹⁾		pv	2,8 N/mm ² · m/s
Permissible specific bearing load ²⁾	Static	p _{max}	200 N/mm ²
	Rotary, oscillating		140 N/mm ²
Permissible sliding velocity		v _{max}	0,18 m/s
Permissible operating temperature		∅	-20 °C to +130 °C
Friction coefficient		μ	0,03 to 0,2
Operating life behaviour with:			
Dry running		+++	
Grease and oil lubrication		+	
Media lubrication, water lubrication		+	

11
 pv diagram

p = specific bearing load
 v = sliding velocity

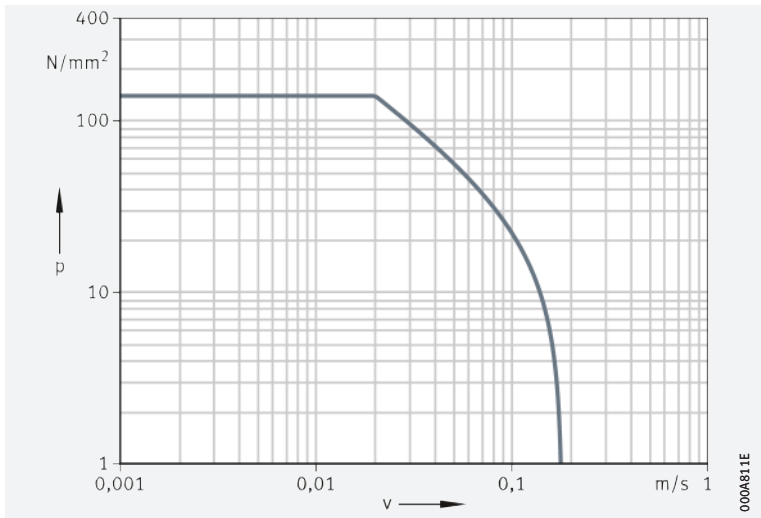

6.3 ELGOGLIDE plain bushes, maintenance-free

Features

Maintenance-free ELGOGLIDE plain bushes ZGB are radial dry plain bearings and comprise a cylindrical steel backing with a sliding layer with very long life and low friction made from ELGOGLIDE. They can support very high radial loads with unilateral load direction and high static loads. In addition, they are highly suitable for high alternating loads and swivel motions.

12
 ELGOGLIDE plain bushes, maintenance-free

- ① ELGOGLIDE plain bush, with steel backing, open ZGB
 ② ELGOGLIDE plain bush, with steel backing, with seal lips ZGB...-2RS

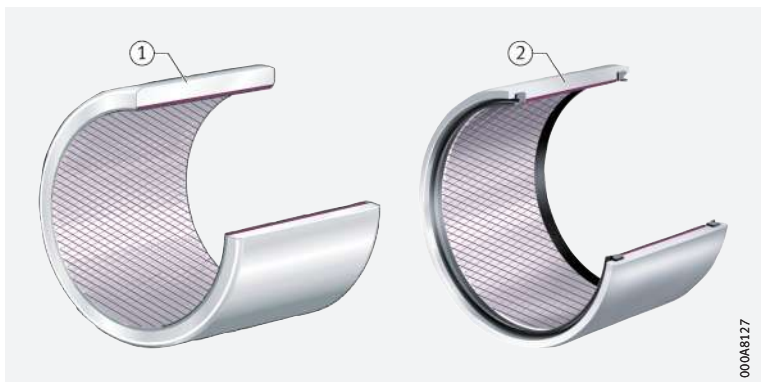



Further information:

- Catalogue Plain Bearings ►  HG 1
- Product selection and information system *medias professional* ► <https://medias.schaeffler.com>
- Download and ordering via ► <https://www.schaeffler.de/std/1D64>.

Maintenance-free plain bearing material

The sliding layer comprises a 0,5 mm thick layer of ELGOGLIDE, is embedded in synthetic resin and is attached by a high strength bond to the support body. The flow behaviour of the sliding layer can be, in conjunction with the supporting body, almost negligible even under very high load. The adhesive bond is resistant to moisture and swelling.

 *ELGOGLIDE designs*

For differing requirements, the following are available:

- ELGOGLIDE
the standard material for very high dynamic contact pressures from 25 N/mm² to 300 N/mm² and a long operating life
- ELGOGLIDE-W11
the material for dynamic contact pressures from 1 N/mm² to 150 N/mm² and with low coefficients of friction even at low contact pressures.

Areas of application

ELGOGLIDE plain bushes can support higher forces than conventional plain bushes and can therefore be used to replace steel, bronze and plastic plain bearings.

Typical areas of application include construction and agricultural machinery as well as conveying equipment, civil engineering and shipbuilding.

Available designs

Available standard dimension ranges ► 1799  7. ELGOGLIDE filament wound bushes are available by agreement with integrated lip seals, on one side in design RS or on both sides in design 2RS.



ELGOGLIDE plain bushes with special dimensions or special tolerance classes are possible and may be available by agreement with Schaeffler.

 7
Dimension range

ELGOGLIDE plain bush	Dimensions mm	
	from	to
Inside diameter	30	200
Outside diameter	36	220
Width	30	180

Suffixes

Suffixes for available designs ► 1799  8.



 8
Available designs

Suffix	Description	Design
W1	Support body made from corrosion-resistant steel	Special design, available by agreement
W11	By agreement, for low contact pressures (starting as low as 1 N/mm ²) and minimal friction	
2RS	Standard lip seal on both sides	
RS	Standard lip seal on one side	

6.4 Plain bearings for diverse requirements

The table gives a compilation of the design features of plain bushes.

 **9**
 Composite plain bearings
 with plain bushes









Plain bearings		Metal/polymer composite plain bearings	
<ul style="list-style-type: none"> ■ Standard design □ Optional ✓ Suitable – Not suitable/not applicable 		E40, E40-B 	
detailed information 		1791	
Type of maintenance			
Maintenance-free		✓	
Low-maintenance		–	
Water-resistant		□	
Technical data			
Permissible specific bearing load	Static	N/mm ²	250
	Dynamic	N/mm ²	140
Permissible sliding velocity		m/s	2,5
Maximum permissible pv value in continuous operation		N/mm ² · m/s	1,8
Permissible operating temperature ⁴⁾		°C	–200 to +280
Friction coefficient			0,03 to 0,25
Lubrication			
Dry running			✓
Grease and oil lubrication			–
Hydrodynamic operation			✓
Media lubrication			✓
Possible application			
Increased corrosion resistance			E40-B ■ E40 □
Use in water			E40-B □
Integrated sealing possible			–
Standard designs			EGB, EGF, EGW, EGS 

¹⁾ For static loads of more than 180 N/mm², the design of ELGOTEX filament wound bushes must be checked by the Schaeffler engineering service.

²⁾ Standard bushes have a static load carrying capacity of 300 N/mm². If a material of higher strength is used for the steel support body, this value can be increased to 500 N/mm².

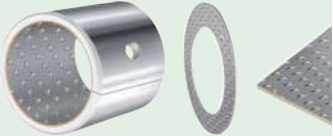
³⁾ Certified specific bearing load $p_{max} = 15 \text{ N/mm}^2$ for use in rudder carrier bearings in accordance with MCM-0112 (Germanischer Lloyd).

⁴⁾ Valid for open design (without seals).

E50	Filament wound bushes		Plain bushes
	ELGOTEX	ELGOTEX-WA	ELGOGLIDE
			
1793	1796	1797	1798
-	✓	-	✓
✓	-	-	-
-	-	✓	-
140	200 ¹⁾	150	500 ²⁾
70	140	50 ³⁾	300
2,5	0,18	0,024	0,3
3	2,8	1,2	7
-40 to +110	-20 to +130	-20 to +130	-50 to +150
0,02 to 0,2	0,03 to 0,2	0,05 to 0,15	0,02 to 0,2
-	✓	✓	✓
✓	✓	✓	-
-	-	-	-
-	✓	✓	-
□	■	■	□
-	□	■	-
-	□	□	□
EGB, EGW, EGS	ZWB	ZWB...WA	ZGB
			

Product index

Series	Description	Page
10	Self-aligning ball bearings with cylindrical bore	386
112	Self-aligning ball bearings with extended inner ring	400
12	Self-aligning ball bearings with cylindrical bore	386
12...-K	Self-aligning ball bearings with tapered bore, taper 1:12	386
13	Self-aligning ball bearings with cylindrical bore	386
13...-K	Self-aligning ball bearings with tapered bore, taper 1:12	388
160	Deep groove ball bearings	238
2...-KRR	Deep groove ball bearings with extended inner ring (radial insert ball bearings), cylindrical outer ring and R type seal	1538
2...-NPP-B	Self-aligning deep groove ball bearings (radial insert ball bearings), spherical outer ring and P type seal	1536
202	Barrel roller bearings with cylindrical bore	654
202...-K	Barrel roller bearings with tapered bore, taper 1:12	654
203	Barrel roller bearings with cylindrical bore	654
203...-K	Barrel roller bearings with tapered bore, taper 1:12	654
213...-E1	Spherical roller bearings with cylindrical bore	696
213...-E1-K	Spherical roller bearings with tapered bore, taper 1:12	696
22	Self-aligning ball bearings with cylindrical bore	386
22...-2RS	Self-aligning ball bearings with cylindrical bore, contact seal on both sides	386
22...-K	Self-aligning ball bearings with tapered bore, taper 1:12	388
22...-K-2RS	Self-aligning ball bearings with tapered bore, taper 1:12, contact seal on both sides	388
222...-BEA	Spherical roller bearings with cylindrical bore	726
222...-BEA-K	Spherical roller bearings with tapered bore, taper 1:12	726
222...-E1	Spherical roller bearings with cylindrical bore	696

Series	Description	Page
222...-E1-K	Spherical roller bearings with tapered bore, taper 1:12	696
223...-BEA	Spherical roller bearings with cylindrical bore	726
223...-BEA-K	Spherical roller bearings with tapered bore, taper 1:12	726
223...-E1	Spherical roller bearings with cylindrical bore	696
223...-E1-K	Spherical roller bearings with tapered bore, taper 1:12	696
223...-E1-K-T41A	Spherical roller bearings, for oscillating load with restricted diameter tolerances, with tapered bore	788
223...-E1-T41A	Spherical roller bearings, for oscillating load with restricted diameter tolerances, with cylindrical bore	788
23	Self-aligning ball bearings with cylindrical bore	386
23...-2RS	Self-aligning ball bearings with cylindrical bore, contact seal on both sides	386
23...-K	Self-aligning ball bearings with tapered bore, taper 1:12	388
230	Spherical roller bearings with cylindrical bore	740
230...-E1	Spherical roller bearings with cylindrical bore	704
230...-E1A	Spherical roller bearings with cylindrical bore	704
230...-E1A-K	Spherical roller bearings with tapered bore, taper 1:12	704
230...-E1-K	Spherical roller bearings with tapered bore, taper 1:12	704
230...-K	Spherical roller bearings with tapered bore, taper 1:12	740
231	Spherical roller bearings with cylindrical bore	738
231...-2RSR	Spherical roller bearings with cylindrical bore, lip seal on both sides	754
231...-E1	Spherical roller bearings with cylindrical bore	702
231...-E1A	Spherical roller bearings with cylindrical bore	702
231...-E1A-K	Spherical roller bearings with tapered bore, taper 1:12	702
231...-E1-K	Spherical roller bearings with tapered bore, taper 1:12	702
231...-K	Spherical roller bearings with tapered bore, taper 1:12	740
232	Spherical roller bearings with cylindrical bore	738
232...-E1	Spherical roller bearings with cylindrical bore	700
232...-E1A	Spherical roller bearings with cylindrical bore	700
232...-E1A-K	Spherical roller bearings with tapered bore, taper 1:12	700
232...-E1-K	Spherical roller bearings with tapered bore, taper 1:12	700
232...-K	Spherical roller bearings with tapered bore, taper 1:12	738
233...-A-MA-T41A	Spherical roller bearings, for oscillating load with restricted diameter tolerances, with cylindrical bore	788
2344	Super precision axial angular contact ball bearings, double direction	1262
238	Spherical roller bearings with cylindrical bore	738
238...-K	Spherical roller bearings with tapered bore, taper 1:12	738
239	Spherical roller bearings with cylindrical bore	718
239...-K	Spherical roller bearings with tapered bore, taper 1:12	718
240	Spherical roller bearings with cylindrical bore	740
240...-BE	Spherical roller bearings with cylindrical bore	706
240...-BE-2VSR	Spherical roller bearings with cylindrical bore, lip seal on both sides	752
240...-BEA	Spherical roller bearings with cylindrical bore	728
240...-BEA-K30	Spherical roller bearings with tapered bore, taper 1:30	728
240...-BE-K30	Spherical roller bearings with tapered bore, taper 1:30	706
240...-K30	Spherical roller bearings with tapered bore, taper 1:30	740
241	Spherical roller bearings with cylindrical bore	738
241...-BE	Spherical roller bearings with cylindrical bore	704
241...-BE-2VSR	Spherical roller bearings with cylindrical bore, lip seal on both sides	752
241...-BEA	Spherical roller bearings with cylindrical bore	734
241...-BEA-K30	Spherical roller bearings with tapered bore, taper 1:30	734
241...-BE-K30	Spherical roller bearings with tapered bore, taper 1:30	704
241...-K30	Spherical roller bearings with tapered bore, taper 1:30	740
248	Spherical roller bearings with cylindrical bore	734
249	Spherical roller bearings with cylindrical bore	740
249...-K30	Spherical roller bearings with tapered bore, taper 1:30	740
292...-E1	Axial spherical roller bearings, single direction	1130

Series	Description	Page
293..-E1	Axial spherical roller bearings, single direction	1130
294..-E1	Axial spherical roller bearings, single direction	1130
30..-B	Angular contact ball bearings, double row, contact angle $\alpha = 25^\circ$	330
30..-B-2RS	Angular contact ball bearings, double row, lip seal on both sides, contact angle $\alpha = 25^\circ$	330
30..-B-2RSR	Angular contact ball bearings, double row, lip seal on both sides, contact angle $\alpha = 25^\circ$	330
30..-B-2RZ	Angular contact ball bearings, double row, non-contact radial seal on both sides, contact angle $\alpha = 25^\circ$	330
30..-B-2Z	Angular contact ball bearings, double row, sheet metal gap seal on both sides, contact angle $\alpha = 25^\circ$	330
302	Tapered roller bearings, single row to DIN/ISO	586
302..-DF	Two tapered roller bearings, single row to DIN/ISO, matched in pairs in an X arrangement	632
303	Tapered roller bearings, single row to DIN/ISO	586
313	Tapered roller bearings, single row to DIN/ISO	586
313..-DF	Two tapered roller bearings, single row to DIN/ISO, matched in pairs in an X arrangement	632
32	Angular contact ball bearings, double row, with filling slots, contact angle $\alpha = 35^\circ$	342
32..-B	Angular contact ball bearings, double row, contact angle $\alpha = 25^\circ$	330
32..-B-2RS	Angular contact ball bearings, double row, contact seal on both sides, axial contact, contact angle $\alpha = 25^\circ$	330
32..-B-2RSR	Angular contact ball bearings, double row, lip seal on both sides, contact angle $\alpha = 25^\circ$	342
32..-B-2Z	Angular contact ball bearings, double row, sheet metal gap seal on both sides, contact angle $\alpha = 25^\circ$	330
32..-BD	Angular contact ball bearings, double row, contact angle $\alpha = 30^\circ$	332
32..-BD-2HRS	Angular contact ball bearings, double row, lip seal on both sides, contact angle $\alpha = 30^\circ$	332
32..-BD-2Z	Angular contact ball bearings, double row, sheet metal gap seal on both sides, contact angle $\alpha = 30^\circ$	332
320	Tapered roller bearings, single row to DIN/ISO	586
320..-DF	Two tapered roller bearings, single row to DIN/ISO, matched in pairs in an X arrangement	632
322	Tapered roller bearings, single row to DIN/ISO	586
322..-DF	Two tapered roller bearings, single row to DIN/ISO, matched in pairs in an X arrangement	632
323	Tapered roller bearings, single row to DIN/ISO	586
329	Tapered roller bearings, single row to DIN/ISO	586
33	Angular contact ball bearings, double row, with filling slots, contact angle $\alpha = 35^\circ$	342
33..-B	Angular contact ball bearings, double row, contact angle $\alpha = 25^\circ$	330
33..-B-2RS	Angular contact ball bearings, double row, lip seal on both sides, contact angle $\alpha = 25^\circ$	330
33..-B-2RSR	Angular contact ball bearings, double row, lip seal on both sides, contact angle $\alpha = 25^\circ$	340
33..-B-2Z	Angular contact ball bearings, double row, sheet metal gap seal on both sides, contact angle $\alpha = 25^\circ$	330
33..-BD	Angular contact ball bearings, double row, contact angle $\alpha = 30^\circ$	332
33..-BD-2HRS	Angular contact ball bearings, double row, lip seal on both sides, contact angle $\alpha = 30^\circ$	332

Series	Description	Page
33..-BD-ZZ	Angular contact ball bearings, double row, sheet metal gap seal on both sides, contact angle $\alpha = 30^\circ$	332
33..-DA	Angular contact ball bearings, double row, separable, with split inner ring, contact angle $\alpha = 45^\circ$	334
330	Tapered roller bearings, single row to DIN/ISO	586
330..-DF	Two tapered roller bearings, single row to DIN/ISO, matched in pairs in X arrangement	634
331	Tapered roller bearings, single row to DIN/ISO	590
332	Tapered roller bearings, single row to DIN/ISO	586
38..-B	Angular contact ball bearings, double row, contact angle $\alpha = 25^\circ$	330
38..-B-2RS	Angular contact ball bearings, double row, lip seal on both sides, contact angle $\alpha = 25^\circ$	330
38..-B-2RZ	Angular contact ball bearings, double row, non-contact radial seal on both sides, contact angle $\alpha = 25^\circ$	330
42..-B	Deep groove ball bearings, double row	276
43..-B	Deep groove ball bearings, double row	276
511	Axial deep groove ball bearings, single direction	1052
512	Axial deep groove ball bearings, single direction	1052
513	Axial deep groove ball bearings, single direction	1052
514	Axial deep groove ball bearings, single direction	1052
522	Axial deep groove ball bearings, double direction	1064
523	Axial deep groove ball bearings, double direction	1064
524	Axial deep groove ball bearings, double direction	1064
532	Axial deep groove ball bearings, single direction, with spherical housing locating washer	1052
533	Axial deep groove ball bearings, single direction, with spherical housing locating washer	1052
542	Axial deep groove ball bearings, double direction, with spherical housing locating washer	1064
543	Axial deep groove ball bearings, double direction, with spherical housing locating washer	1064
60	Deep groove ball bearings	240
60..-2RSR	Deep groove ball bearings, lip seal on both sides	240
60..-ZZ	Deep groove ball bearings, sheet metal gap seal on both sides	232
60..-C	Deep groove ball bearings, modified internal construction (Generation C)	234
60..-C-2BRS	Deep groove ball bearings, modified internal construction (Generation C), labyrinth seal on both sides	234
60..-C-2HRS	Deep groove ball bearings, modified internal construction (Generation C), lip seal on both sides	234
60..-C-ZZ	Deep groove ball bearings, modified internal construction (Generation C), sheet metal gap seal on both sides	234
618	Deep groove ball bearings	234
618..-2RSR	Deep groove ball bearings, lip seal on both sides	234
618..-2RZ	Deep groove ball bearings, non-contact radial seal on both sides	252
618..-ZZ	Deep groove ball bearings, sheet metal gap seal on both sides	234
619	Deep groove ball bearings	234
619..-2RSR	Deep groove ball bearings, lip seal on both sides	234
619..-2RZ	Deep groove ball bearings, non-contact radial seal on both sides	252
619..-ZZ	Deep groove ball bearings, sheet metal gap seal on both sides	234
62	Deep groove ball bearings	256
62..-2RSR	Deep groove ball bearings, lip seal on both sides	256
62..-ZZ	Deep groove ball bearings, sheet metal gap seal on both sides	232

Series	Description	Page
62..-C	Deep groove ball bearings, modified internal construction (Generation C)	232
62..-C-2BRS	Deep groove ball bearings, modified internal construction (Generation C), labyrinth seal on both sides	232
62..-C-2HRS	Deep groove ball bearings, modified internal construction (Generation C), lip seal on both sides	232
62..-C-2Z	Deep groove ball bearings, modified internal construction (Generation C), sheet metal gap seal on both sides	232
622..-2RSR	Deep groove ball bearings, lip seal on both sides	234
623..-2RSR	Deep groove ball bearings, lip seal on both sides	234
63	Deep groove ball bearings	234
63..-2RSR	Deep groove ball bearings, lip seal on both sides	234
63..-2Z	Deep groove ball bearings, sheet metal gap seal on both sides	232
63..-C	Deep groove ball bearings, modified internal construction (Generation C)	236
63..-C-2BRS	Deep groove ball bearings, modified internal construction (Generation C), labyrinth seal on both sides	236
63..-C-2HRS	Deep groove ball bearings, modified internal construction (Generation C), lip seal on both sides	236
63..-C-2Z	Deep groove ball bearings, modified internal construction (Generation C), sheet metal gap seal on both sides	236
64	Deep groove ball bearings	240
68..-2Z	Deep groove ball bearings, sheet metal gap seal on both sides	232
69..-2Z	Deep groove ball bearings, sheet metal gap seal on both sides	232
70..-B	Angular contact ball bearings, single row, contact angle $\alpha = 40^\circ$	304
70..-B-2RS	Angular contact ball bearings, single row, contact angle $\alpha = 40^\circ$, lip seal on both sides	304
718..-B	Angular contact ball bearings, single row, contact angle $\alpha = 40^\circ$	306
72..-B	Angular contact ball bearings, single row, contact angle $\alpha = 40^\circ$	304
72..-B-2RS	Angular contact ball bearings, single row, contact angle $\alpha = 40^\circ$, lip seal on both sides	304
73..-B	Angular contact ball bearings, single row, contact angle $\alpha = 40^\circ$	304
73..-B-2RS	Angular contact ball bearings, single row, contact angle $\alpha = 40^\circ$, lip seal on both sides	304
74..-B	Angular contact ball bearings, single row, contact angle $\alpha = 40^\circ$	306
7602	Axial angular contact ball bearings, single direction, contact angle $\alpha = 60^\circ$, restricted tolerances	1300
7602..-2RS	Axial angular contact ball bearings, single direction, contact angle $\alpha = 60^\circ$, restricted tolerances, lip seal on both sides	1310
7603	Axial angular contact ball bearings, single direction, contact angle $\alpha = 60^\circ$, restricted tolerances	1300
7603..-2RS	Axial angular contact ball bearings, single direction, contact angle $\alpha = 60^\circ$, restricted tolerances, lip seal on both sides	1310
811	Axial cylindrical roller bearings, single direction, comprising K811, GS, WS	1088
812	Axial cylindrical roller bearings, single direction, comprising K812, GS, WS	1088
893	Axial cylindrical roller bearings, single direction, comprising K893, GS, WS	1088
894	Axial cylindrical roller bearings, single direction, comprising K894, GS, WS	1088

Series	Description	Page
AH(X)23	Withdrawal sleeves, taper 1:12	1714
AH(X)3	Withdrawal sleeves, taper 1:12	1714
AH(X)30	Withdrawal sleeves, taper 1:12	1716
AH(X)31	Withdrawal sleeves, taper 1:12	1715
AH(X)32	Withdrawal sleeves, taper 1:12	1715
AH2	Withdrawal sleeves, taper 1:12	1714
AH22	Withdrawal sleeves, taper 1:12	1720
AH240	Withdrawal sleeves, taper 1:30	1716
AH241	Withdrawal sleeves, taper 1:30	1716
AH33	Withdrawal sleeves, taper 1:12	1714
AH39	Withdrawal sleeves, taper 1:12	1720
AM	Precision locknuts, segments for clamping	1346
AMS	Sockets for precision locknuts AM	1349
AS	Axial bearing washers, suitable for AXK and AXW	1111
AXK	Axial needle roller and cage assemblies	1111
AXW	Axial needle roller bearings with centring spigot, single direction	1112
AY..-NPP-B	Radial insert ball bearings, spherical outer ring, grub screws in inner ring and P type seal	1520
B70..-C	Super precision angular contact ball bearings, contact angle $\alpha = 15^\circ$, restricted tolerances	1178
B70..-E	Super precision angular contact ball bearings, contact angle $\alpha = 25^\circ$, restricted tolerances	1178
B719..-C	Super precision angular contact ball bearings, contact angle $\alpha = 15^\circ$, restricted tolerances	1178
B719..-E	Super precision angular contact ball bearings, contact angle $\alpha = 25^\circ$, restricted tolerances	1178
B72..-C	Super precision angular contact ball bearings, contact angle $\alpha = 15^\circ$, restricted tolerances	1178
B72..-E	Super precision angular contact ball bearings, contact angle $\alpha = 25^\circ$, restricted tolerances	1178
BAX	Super precision angular contact ball bearings	1264
BE	Radial insert ball bearings, cylindrical outer ring, with steel aligning ring and P type seal	1548
BK	Drawn cup needle roller bearings with closed end	900
BK..-RS	Drawn cup needle roller bearings with closed end, sealed on one side	907
BSB	Axial angular contact ball bearings, single direction, contact angle $\alpha = 60^\circ$, restricted tolerances	1304
BSB..-ZZ-SU	Axial angular contact ball bearings, single direction, contact angle $\alpha = 60^\circ$, restricted tolerances, gap seal on both sides, greased	1310
BSB..-SU	Axial angular contact ball bearings, single direction, contact angle $\alpha = 60^\circ$, restricted tolerances	1300
BSB..-SU-L055	Axial angular contact ball bearings, single direction, contact angle $\alpha = 60^\circ$, restricted tolerances, greased	1300
C	Toroidal roller bearings, cylindrical bore, with sheet steel cage, guided by rollers	832
C..-K	Toroidal roller bearings, tapered bore, taper 1:12, with sheet steel cage, guided by rollers	832
C..-K30-M1B	Toroidal roller bearings, tapered bore, taper 1:30, with brass cage, guided on inner ring	842
C..-K30-V	Toroidal roller bearings, tapered bore, taper 1:30, full complement	832
C..-K-M	Toroidal roller bearings, tapered bore, taper 1:12, with brass cage, guided by rollers	842
C..-K-M1B	Toroidal roller bearings, tapered bore, taper 1:12, with brass cage, guided on inner ring	838
C..-K-V	Toroidal roller bearings, tapered bore, taper 1:12, full complement	832
C..-M	Toroidal roller bearings, cylindrical bore, with brass cage, guided by rollers	842
C..-M1B	Toroidal roller bearings, cylindrical bore, with brass cage, guided on inner ring	838

Series	Description	Page
C...V	Toroidal roller bearings, cylindrical bore, full complement	832
CRB	Radial insert ball bearings, with rubber interliner, eccentric locking collar and P type seal	1546
DKLFA...2RS	Triple row angular contact ball bearings with flange, with fixing holes, lip seal on both sides	1320
DRS	Seal carrier assemblies, for ZARF, ZARF...L, with integral rotary shaft seal	1344
E...KLL	Radial insert ball bearings, cylindrical outer ring, eccentric locking collar and L type seal	1516
E...KRR	Radial insert ball bearings, cylindrical outer ring, eccentric locking collar and R type seal	1516
E...KRR-B	Radial insert ball bearings, spherical outer ring, eccentric locking collar and R type seal	1508
G	Sealing rings, NBR elastomer, single lip	1036
G...KRR-B-AS2/V	Radial insert ball bearings, spherical outer ring, eccentric locking collar and R type seal, inch size bore, relubrication facility	1524
GAY...NPP-B	Radial insert ball bearings, spherical outer ring, grub screws in inner ring and P type seal, inch size bore	1520
GAY...NPP-B-AS2/V	Radial insert ball bearings, spherical outer ring, grub screws in inner ring and P type seal, inch size bore	1524
GAY...NPP-B-FA164	Radial insert ball bearings, spherical outer ring, grub screws in inner ring and P type seal, for high temperatures, relubrication facility	1520
GE...KLL-B	Radial insert ball bearings, spherical outer ring, eccentric locking collar and L type seal, relubrication facility	1508
GE...KRR-B	Radial insert ball bearings, spherical outer ring, eccentric locking collar and R type seal, relubrication facility	1508
GE...KRR-B-2C	Radial insert ball bearings, spherical outer ring, eccentric locking collar and R type seal, flinger shields, relubrication facility	1508
GE...KRR-B-FA101	Radial insert ball bearings, spherical outer ring, eccentric locking collar and R type seal, for high and low temperatures, relubrication facility	1508
GE...KRR-B-FA125	Radial insert ball bearings, spherical outer ring, eccentric locking collar and R type seal, Corrotect, relubrication facility	1556
GE...KRR-B-FA164	Radial insert ball bearings, spherical outer ring, eccentric locking collar and R type seal, for high temperatures, relubrication facility	1508
GE...KTT-B	Radial insert ball bearings, spherical outer ring, eccentric locking collar and T type seal, relubrication facility	1508
GLE...KRR-B	Radial insert ball bearings, spherical outer ring, drive slot in inner ring and R type seal, relubrication facility	1534
GNE...KRR-B	Radial insert ball bearings, spherical outer ring, eccentric locking collar and R type seal, heavy series, relubrication facility	1510
GR	Sealing rings, NBR elastomer, single lip, external steel reinforcement	1036
GRA...NPP-B-AS2/V	Radial insert ball bearings, spherical outer ring, eccentric locking collar and P type seal, inch size bore, relubrication facility	1524
GRAE...NPP-B	Radial insert ball bearings, spherical outer ring, eccentric locking collar and P type seal, relubrication facility	1508
GRAE...NPP-B-FA125	Radial insert ball bearings, spherical outer ring, eccentric locking collar and P type seal, Corrotect, relubrication facility	1556
GS811	Housing locating washers	1089
GS812	Housing locating washers	1089
GS893	Housing locating washers	1089

Series	Description	Page
GS894	Housing locating washers	1089
GSH...2RSR-B	Radial insert ball bearings, spherical outer ring, adapter sleeve and RSR type seal, relubrication facility	1532
GVK...KTT-B	Self-aligning deep groove ball bearings, spherical outer ring, square bore and T type seal, relubrication facility	1540
GVKE...KRR-B	Self-aligning deep groove ball bearings, spherical outer ring, square bore and R type seal	1540
GY...KRR-B-AS2/V	Radial insert ball bearings, spherical outer ring, grub screws in inner ring and R type seal, inch size bore, relubrication facility	1524
GYE...KRR-B	Radial insert ball bearings, spherical outer ring, grub screws in inner ring and R type seal, relubrication facility	1520
H2	Adapter sleeves, with locknut and retainer, taper 1:12	1700
H23	Adapter sleeves, with locknut and retainer, taper 1:12	1700
H240	Adapter sleeves, with locknut and retainer, taper 1:30	1701
H241	Adapter sleeves, with locknut and retainer, taper 1:30	1701
H3	Adapter sleeves, with locknut and retainer, taper 1:12	1700
H30	Adapter sleeves, with locknut and retainer, taper 1:12	1702
H31	Adapter sleeves, with locknut and retainer, taper 1:12	1701
H32	Adapter sleeves, with locknut and retainer, taper 1:12	1707
H33	Adapter sleeves, with locknut and retainer, taper 1:12	1700
H39	Adapter sleeves, with locknut and retainer, taper 1:12	1704
HC70...-E	Super precision angular contact ball bearings, contact angle $\alpha = 25^\circ$, with ceramic balls, restricted tolerances	1178
HC70...-EDLR	Super precision angular contact ball bearings, contact angle $\alpha = 25^\circ$, with ceramic balls, restricted tolerances, in Direct Lube design	1236
HC719...-E	Super precision angular contact ball bearings, contact angle $\alpha = 25^\circ$, with ceramic balls, restricted tolerances	1178
HC719...-EDLR	Super precision angular contact ball bearings, contact angle $\alpha = 25^\circ$, with ceramic balls, restricted tolerances, in Direct Lube design	1236
HCB70...-C	Super precision angular contact ball bearings, contact angle $\alpha = 15^\circ$, with ceramic balls, restricted tolerances	1178
HCB70...-CDLR	Super precision angular contact ball bearings, contact angle $\alpha = 15^\circ$, with ceramic balls, restricted tolerances, in Direct Lube design	1236
HCB70...-E	Super precision angular contact ball bearings, contact angle $\alpha = 25^\circ$, with ceramic balls, restricted tolerances	1178
HCB70...-EDLR	Super precision angular contact ball bearings, contact angle $\alpha = 25^\circ$, with ceramic balls, restricted tolerances, in Direct Lube design	1236
HCB719...-C	Super precision angular contact ball bearings, contact angle $\alpha = 15^\circ$, with ceramic balls, restricted tolerances	1178
HCB719...-CDLR	Super precision angular contact ball bearings, contact angle $\alpha = 15^\circ$, with ceramic balls, restricted tolerances, in Direct Lube design	1236
HCB719...-E	Super precision angular contact ball bearings, contact angle $\alpha = 25^\circ$, with ceramic balls, restricted tolerances	1178
HCB719...-EDLR	Super precision angular contact ball bearings, contact angle $\alpha = 25^\circ$, with ceramic balls, restricted tolerances, in Direct Lube design	1236
HCB72...-C	Super precision angular contact ball bearings, contact angle $\alpha = 15^\circ$, with ceramic balls, restricted tolerances	1178

Series	Description	Page
HCB72...-E	Super precision angular contact ball bearings, contact angle $\alpha = 25^\circ$, with ceramic balls, restricted tolerances	1178
HCN10...-K-PVPA1-SP	Super precision cylindrical roller bearings, non-locating bearings, with tapered bore, taper 1:12, separable, with cage, with ceramic rollers	1248
HF	Drawn cup roller clutches, without bearing arrangement, with steel springs	1021
HF...-KF	Drawn cup roller clutches, without bearing arrangement, with plastic springs	1021
HF...-KF-R	Drawn cup roller clutches without bearing arrangement, with plastic springs, with knurling	1021
HF...-R	Drawn cup roller clutches without bearing arrangement, with steel springs, with knurling	1021
HFL	Drawn cup roller clutches, with plain or rolling bearings, steel springs	1023
HFL...-KF	Drawn cup roller clutches, with plain or rolling bearings, plastic springs	1023
HFL...-KF-R	Drawn cup roller clutches, with plain or rolling bearings, plastic springs, with knurling	1023
HFL...-R	Drawn cup roller clutches, with plain or rolling bearings, steel springs, with knurling	1023
HJ	L-section rings	452
HJ...-E	L-section rings	450
HK	Drawn cup needle roller bearings with open ends	900
HK...-2RS	Drawn cup needle bearings with open ends, sealed on both sides	906
HK...-RS	Drawn cup needle bearings with open ends, sealed on one side	906
HM	Locknuts	1739
HM30	Locknuts	1739
HM31	Locknuts	1739
HMZ	Shaft nuts, metric fine pitch thread, with clamping screws	1742
HMZ30	Shaft nuts, trapezoidal thread, with clamping screws	1742
HN	Drawn cup needle roller bearings, full complement	908
HS70...-C	Super precision angular contact ball bearings, contact angle $\alpha = 15^\circ$, restricted tolerances	1178
HS70...-E	Super precision angular contact ball bearings, contact angle $\alpha = 25^\circ$, restricted tolerances	1178
HS719...-C	Super precision angular contact ball bearings, contact angle $\alpha = 15^\circ$, restricted tolerances	1178
HS719...-E	Super precision angular contact ball bearings, contact angle $\alpha = 25^\circ$, restricted tolerances	1178
IR	Inner rings without lubrication hole, precision machined	998
IR...-IS1	Inner rings with lubrication hole, precision machined	1004
JK05	Integral tapered roller bearings, sealed on one side	636
K	Needle roller and cage assemblies	872
K...-ZW	Needle roller and cage assemblies, double row	874
K811	Axial cylindrical roller and cage assemblies, single row	1088
K812	Axial cylindrical roller and cage assemblies, single row	1088
K893	Axial cylindrical roller and cage assemblies, single row	1088
K894	Axial cylindrical roller and cage assemblies, single row	1088
KLR	Track rollers with plastic tyre, sealed on both sides	1447
KM	Locknuts	1738
KML	Locknuts	1738
KR	Stud type needle roller bearing track rollers with axial guidance, gap seal on both sides	1422
KR...-PP	Stud type needle roller bearing track rollers with axial guidance, plastic axial plain washer on both sides	1422
KR52...-2RS	Stud type ball bearing track rollers, double row, lip seal on both sides	1444

Series	Description	Page
KRE..-PP	Stud type needle roller bearing track rollers with axial guidance, with eccentric collar, plastic axial plain washer on both sides	1422
KRV..-PP	Stud type needle roller bearing track rollers with axial guidance, full complement, plastic axial plain washer on both sides	1422
K-Series	Tapered roller bearings, single row to ANSI/ABMA	614
LR	Inner rings without lubrication hole, increased tolerances	901
LR2	Yoke type ball bearing track rollers, sealed on both sides	1440
LR50	Yoke type ball bearing track rollers, double row, sealed on both sides	1441
LR52	Yoke type ball bearing track rollers, double row, sealed on both sides	1442
LR53	Yoke type ball bearing track rollers, double row, sealed on both sides	1442
LR6	Yoke type ball bearing track rollers, sealed on both sides	1440
LSL1923	Cylindrical roller bearings with disc cage, semi-locating bearings	494
MB	Tab washers	1744
MBL	Tab washers	1744
MS30	Retaining brackets, with hexagon head cap screw	1746
MS31	Retaining brackets, with hexagon head cap screw	1746
N10..-K-M1-SP	Super precision cylindrical roller bearings, non-locating bearings, with tapered bore, taper 1:12, separable, with cage, with steel rollers	1254
N10..-K-PVPA1-SP	Super precision cylindrical roller bearings, non-locating bearings, with tapered bore, taper 1:12, separable, with cage, with steel rollers	1248
N10..-K-TVP-SP	Super precision cylindrical roller bearings, non-locating bearings, with tapered bore, taper 1:12, separable, with cage, with steel rollers	1248
N2..-E	Cylindrical roller bearings with cage, non-locating bearings	434
N3..-E	Cylindrical roller bearings with cage, non-locating bearings	434
NA22...-2RSR	Yoke type roller bearing track rollers without axial guidance, lip seal on both sides	1417
NA48	Needle roller bearings with ribs, with inner ring	952
NA49	Needle roller bearings with ribs, with inner ring	948
NA49...-2RSR	Needle roller bearings with ribs, with inner ring, lip seal on both sides	955
NA49...-RSR	Needle roller bearings with ribs, with inner ring, lip seal on one side	955
NA69	Needle roller bearings with ribs, with inner ring	948
NA69...-ZW	Needle roller bearings with ribs, double row, with inner ring	949
NAO	Needle roller bearing without ribs, with inner ring	960
NAO...-ZW-ASR1	Needle roller bearings without ribs, double row, with inner ring	960
NATR	Yoke type roller bearing track rollers with axial guidance, gap seal on both sides	1418
NATR..-PP	Yoke type roller bearing track rollers with axial guidance, axial plain washer on both sides	1418
NATV	Yoke type roller bearing track rollers with axial guidance, full complement needle roller set, gap seal on both sides	1418
NATV..-PP	Yoke type roller bearing track rollers with axial guidance, full complement needle roller set, axial plain washer on both sides	1418
NE..-KRR-B	Radial insert ball bearings, spherical outer ring, location by eccentric locking collar, R type seal on both sides	1512

Series	Description	Page
NJ2..-E	Cylindrical roller bearings with cage, semi-locating bearings	450
NJ22..-E	Cylindrical roller bearings with cage, semi-locating bearings	450
NJ23..-E	Cylindrical roller bearings with cage, semi-locating bearings	450
NJ3..-E	Cylindrical roller bearings with cage, semi-locating bearings	450
NJ4	Cylindrical roller bearings with cage, semi-locating bearings	452
NK	Needle roller bearings with ribs, without inner ring	936
NK..-D	Needle roller bearings with ribs, without inner ring, with improved steel cage	936
NK..-TW	Needle roller bearings with ribs, without inner ring, with plastic cage, two short needle rollers per cage pocket	940
NKI	Needle roller bearings with ribs, with inner ring	948
NKI..-TW	Needle roller bearings with ribs, with inner ring, with plastic cage, two short needle rollers per cage pocket	949
NKIA	Needle roller/angular contact ball bearings with inner ring, single direction axial component	990
NKIB	Needle roller/angular contact ball bearings with inner ring, double direction axial component	990
NKIS	Needle roller bearings with ribs, with inner ring	948
NKS	Needle roller bearings with ribs, without inner ring	938
NKX	Axial deep groove ball bearings, single direction axial component, without end cap, for oil lubrication	986
NKX..-Z	Needle roller/axial deep groove ball bearings, single direction axial component, with end cap, for grease lubrication	986
NKXR	Needle roller/axial cylindrical roller bearings, single direction axial component, without end cap, for oil lubrication	988
NKXR..-Z	Needle roller/axial cylindrical roller bearings, single direction axial component, with end cap, for grease lubrication	988
NN30..-AS-K-M-SP	Super precision cylindrical roller bearings, double row, non-locating bearings, with tapered bore, taper 1:12	1258
NN30..-K-TVP	Super precision cylindrical roller bearings, double row, non-locating bearings, with tapered bore, taper 1:12	1256
NNTR..-ZZL	Yoke type roller bearing track rollers with axial guidance, full complement cylindrical roller set, central rib, contact washers with lamellar ring on both sides	1419
NUU49..-S-K-M-SP	Super precision cylindrical roller bearings, double row, non-locating bearings, with tapered bore, taper 1:12	1256
NU10	Cylindrical roller bearings with cage, non-locating bearings	434
NU19	Cylindrical roller bearings with cage, non-locating bearings	448
NU2..-E	Cylindrical roller bearings with cage, non-locating bearings	434
NU22..-E	Cylindrical roller bearings with cage, non-locating bearings	434
NU23..-E	Cylindrical roller bearings with cage, non-locating bearings	434
NU3..-E	Cylindrical roller bearings with cage, non-locating bearings	434
NU4	Cylindrical roller bearings with cage, non-locating bearings	434
NUKR	Stud type cylindrical roller bearing track rollers with axial guidance, full complement, labyrinth seal on both sides	1426

Series	Description	Page
NUKRE	Stud type cylindrical roller bearing track rollers with axial guidance, full complement, with eccentric collar, labyrinth seal on both sides	1426
NUP2...-E	Cylindrical roller bearings with cage, locating bearings	450
NUP22...-E	Cylindrical roller bearings with cage, locating bearings	450
NUP23...-E	Cylindrical roller bearings with cage, locating bearings	450
NUP3...-E	Cylindrical roller bearings with cage, locating bearings	450
NUTR	Yoke type roller bearing track rollers with optimised INA profile and axial guidance, labyrinth seal on both sides	1420
NX	Needle roller/axial deep groove ball bearings, single direction axial component, for oil lubrication	984
NX...-Z	Needle roller/axial deep groove ball bearings, single direction axial component, for grease lubrication	984
PE	Radial insert ball bearings, cylindrical outer ring, with steel aligning ring, location by eccentric locking collar, P type seal on both sides	1548
PNA	Aligning needle roller bearings, with inner ring	963
PWKR...-2RS	Stud type cylindrical roller bearing track rollers with axial guidance, full complement, protected lip seal on both sides	1426
PWKRE...-2RS	Stud type cylindrical roller bearing track rollers with axial guidance, full complement, with eccentric collar, protected lip seal on both sides	1426
PWTR...-2RS	Yoke type roller bearing track rollers with optimised INA profile and axial guidance, protected lip seal on both sides	1420
QJ10	Four point contact bearings, without retaining slots	362
QJ10...-N2	Four point contact bearings, with two retaining slots	362
QJ2	Four point contact bearings, without retaining slots	362
QJ2...-N2	Four point contact bearings, with two retaining slots	364
QJ3	Four point contact bearings, without retaining slots	362
QJ3...-N2	Four point contact bearings, with two retaining slots	362
RA...-NPP	Radial insert ball bearings, cylindrical outer ring, eccentric locking collar and P type seal, inch size bore	1530
RA...-NPP-B	Radial insert ball bearings, spherical outer ring, eccentric locking collar and P type seal, inch size bore	1524
RABR	Radial insert ball bearings, with rubber interliner, eccentric locking collar and P type seal	1546
RAE...-NPP	Radial insert ball bearings, cylindrical outer ring, eccentric locking collar and P type seal	1516
RAE...-NPP-B	Radial insert ball bearings, spherical outer ring, eccentric locking collar and P type seal	1508
RAE...-NPP-NR	Radial insert ball bearings, cylindrical outer ring, eccentric locking collar and P type seal, snap ring	1516
RAL...-NPP	Radial insert ball bearings, cylindrical outer ring, eccentric locking collar and P type seal, inch size bore, light series	1530
RALE...-NPP	Radial insert ball bearings, cylindrical outer ring, eccentric locking collar and P type seal, light series	1516
RALE...-NPP-B	Radial insert ball bearings, spherical outer ring, eccentric locking collar and P type seal, light series	1508
RCR	Radial insert ball bearings, with rubber interliner, eccentric locking collar and P type seal, no relubrication facility	1546
RCSM	Radial insert ball bearings, with rubber interliner, eccentric locking collar and P type seal	1546
RNA22...-2RSR	Yoke type roller bearing track rollers without axial guidance, without inner ring, lip seal on both sides	1417
RNA48	Needle roller bearings with ribs, without inner ring	945
RNA49	Needle roller bearings with ribs, without inner ring	936
RNA49...-2RSR	Needle roller bearings with ribs, without inner ring, lip seal on both sides	954

Series	Description	Page
RNA49..-RSR	Needle roller bearings with ribs, without inner ring, lip seal on one side	954
RNA69	Needle roller bearings with ribs, without inner ring	936
RNA69..-ZW	Needle roller bearings with ribs, double row, without inner ring	940
RNAO	Needle roller bearings without ribs, without inner ring	956
RNAO..-ZW-ASR1	Needle roller bearings without ribs, double row, without inner ring	956
RPNA	Aligning needle roller bearings, without inner ring	962
RSTO	Yoke type roller bearing track rollers without axial guidance, without inner ring	1416
SD	Sealing rings, polyamide and PU elastomer, double lip	1036
SK..-KRR	Self-aligning deep groove ball bearings, cylindrical outer ring, hexagonal bore and R type seal	1544
SK..-KRR-B	Self-aligning deep groove ball bearings, spherical outer ring, hexagonal bore and R type seal	1542
SK..-KTT	Self-aligning deep groove ball bearings, cylindrical outer ring, hexagonal bore and T type seal	1544
SK..-KTT-B	Self-aligning deep groove ball bearings, spherical outer ring, hexagonal bore and T type seal	1542
SL0148	Double row full complement cylindrical roller bearings, locating bearings	544
SL0149	Double row full complement cylindrical roller bearings, locating bearings	542
SL0248	Double row full complement cylindrical roller bearings, non-locating bearings	544
SL0249	Double row full complement cylindrical roller bearings, non-locating bearings	542
SL04..-PP	Double row full complement cylindrical roller bearings, locating bearings, light series, with annular slots, lip seal on both sides	550
SL0450..-PP	Double row full complement cylindrical roller bearings, locating bearings, dimension series 50, with annular slots, lip seal on both sides	550
SL1818	Single row full complement cylindrical roller bearings, semi-locating bearings	520
SL1822	Single row full complement cylindrical roller bearings, semi-locating bearings	514
SL1829	Single row full complement cylindrical roller bearings, semi-locating bearings	514
SL1830	Single row full complement cylindrical roller bearings, semi-locating bearings	514
SL1850	Double row full complement cylindrical roller bearings, semi-locating bearings	542
SL1923	Single row full complement cylindrical roller bearings, semi-locating bearings, self-retaining roller set	514
SNS..-H-D	Plummer block housings, split, for bearings with tapered bore	1650
SNS..-H-D	Plummer block housings, split, for bearings with cylindrical bore	1660
SNS..-Z-D	Plummer block housings, split, for bearings with cylindrical bore	1660
SNV..-F-L	Plummer block housings, split, for bearings with tapered bore	1598
SNV..-F-L	Plummer block housings, split, for bearings with cylindrical bore	1610
STO	Yoke type roller bearing track rollers without axial guidance, with inner ring	1416
SUB	Radial insert ball bearings, spherical outer ring, grub screws in narrow inner ring and RSR type seal, corrosion-resistant VA design	1550
SUC	Radial insert ball bearings, spherical outer ring, grub screws in inner ring and RSR type seal, flinger shields, corrosion-resistant VA design	1552

Series	Description	Page
SUG	Radial insert ball bearings, spherical outer ring, eccentric locking collar and RSR type seal, corrosion-resistant VA design	1554
SX	Crossed roller bearings	1168
T	Tapered roller bearings, single row	586
U	Support washer	1052
UC	Radial insert ball bearings JIS range, spherical outside surface, grub screws in inner ring, Durotect BS coating, relubrication facility	1558
UK	Radial insert ball bearings JIS range, spherical outside surface, with adapter sleeve, Durotect BS coating, relubrication facility	1564
VK...-KTT-B	Self-aligning deep groove ball bearings, spherical outer ring, square bore and T type seal	1540
WS222...-E1	Spherical roller bearings with cylindrical bore, lip seal on both sides	752
WS223...-E1	Spherical roller bearings with cylindrical bore, lip seal on both sides	752
WS811	Shaft locating washers	1089
WS812	Shaft locating washers	1089
WS893	Shaft locating washers	1089
WS894	Shaft locating washers	1089
XC70...-E	Super precision angular contact ball bearings, contact angle $\alpha = 25^\circ$, with ceramic balls, restricted tolerances, with Cronidur rings	1178
XC70...-EDLR	Super precision angular contact ball bearings, contact angle $\alpha = 25^\circ$, with ceramic balls, restricted tolerances, with Cronidur rings, in Direct Lube design	1236
XC719...-E	Super precision angular contact ball bearings, contact angle $\alpha = 25^\circ$, with ceramic balls, restricted tolerances, with Cronidur rings	1178
XC719...-EDLR	Super precision angular contact ball bearings, contact angle $\alpha = 25^\circ$, with ceramic balls, restricted tolerances, with Cronidur rings, in Direct Lube design	1236
YRT	Axial/radial bearings, double direction	1358
YRTC	Axial/radial bearings, double direction	1360
YRTCM	Axial/radial bearings with incremental angular measuring system, double direction	1366
YRTM	Axial/radial bearings with incremental angular measuring system, double direction	1366
YRTCMA	Axial/radial bearings with absolute value angular measuring system, double direction	1370
YRTS	Axial/radial bearings, double direction, for higher speeds	1362
YRTSM	Axial/radial bearings with incremental angular measuring system, double direction, for higher speeds	1368
YRTSMA	Axial/radial bearings with absolute value angular measuring system, double direction, for higher speeds	1372
ZARF	Needle roller/axial cylindrical roller bearings, double direction, with fixing holes	1324
ZARF...-L	Needle roller/axial cylindrical roller bearings, double direction, with fixing holes, long shaft locating washer	1324
ZARN	Needle roller/axial cylindrical roller bearings, double direction, without fixing holes	1334
ZARN...-L	Needle roller/axial cylindrical roller bearings, double direction, without fixing holes, long shaft locating washer	1334
ZKLDf	Axial angular contact ball bearings, double direction	1364
ZKLF...-2RS	Axial angular contact ball bearings, double direction, with fixing holes, lip seal on both sides	1276

Series	Description	Page 
ZKLF..-2RS-2AP	Axial angular contact ball bearings, matched pair, double direction, with fixing holes, lip seal on both sides	1286
ZKLF..-2RS-PE	Axial angular contact ball bearings, less stringent tolerances, double direction, with fixing holes, lip seal on both sides	1284
ZKLF..-2Z	Axial angular contact ball bearings, double direction, with fixing holes, gap seal on both sides	1276
ZKLFA..-2RS	Double row axial angular contact ball bearings with flange, double direction, with fixing holes, lip seal on both sides	1316
ZKLFA..-2Z	Double row axial angular contact ball bearings with flange, double direction, with fixing holes, gap seal on both sides	1316
ZKLN..-2RS	Axial angular contact ball bearings, double direction, without fixing holes, lip seal on both sides	1288
ZKLN..-2RS-2AP	Axial angular contact ball bearings, matched pair, double direction, without fixing holes, lip seal on both sides	1298
ZKLN..-2RS-PE	Axial angular contact ball bearings, less stringent tolerances, double direction, without fixing holes, lip seal on both sides	1296
ZKLN..-2Z	Axial angular contact ball bearings, double direction, without fixing holes, gap seal on both sides	1288
ZKLR..-2RS	Angular contact ball bearing units, double direction, for screw mounting, lip seal on both sides	1314
ZKLR..-2Z	Angular contact ball bearing units, double direction, for screw mounting, gap seal on both sides	1314
ZL2..-DRS	Stud type ball bearing track rollers, single row, sealed	1444
ZL52..-DRS	Stud type ball bearing track rollers, double row, sealed	1444
ZLE52..-2Z	Stud type track rollers with eccentric collar, double row, gap seal on both sides	1446
ZM	Precision locknuts, locking pegs arranged radially	1347
ZMA	Precision locknuts, locking pegs arranged radially, heavy series	1347
ZSL1923	Cylindrical roller bearings with spacers, semi-locating bearings	496

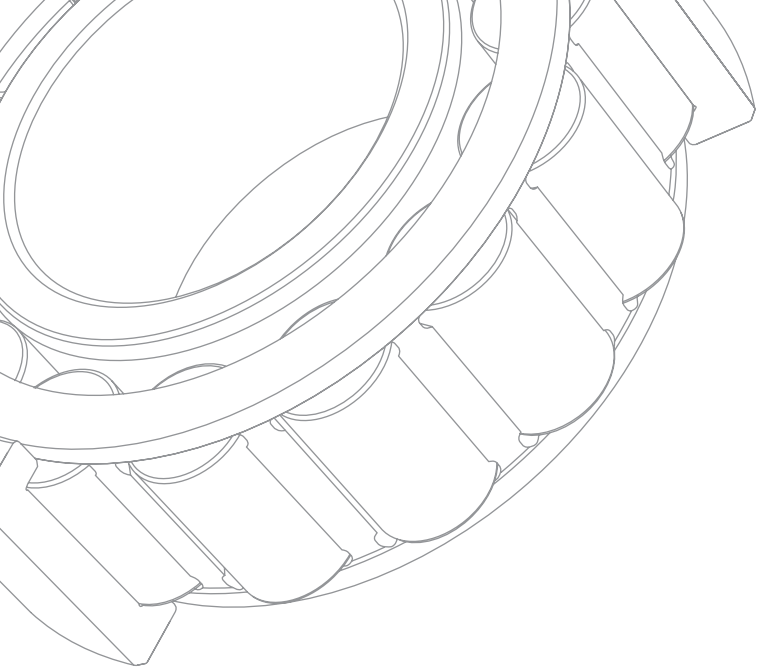

Schaeffler Technologies AG & Co. KG

Georg-Schäfer-Straße 30

97421 Schweinfurt

Germany

Internet www.schaeffler.de/en

E-mail info.de@schaeffler.com

In Germany:

Phone 0180 5003872

Fax 0180 5003873

From other countries:

Phone +49 9721 91-0

Fax +49 9721 91-3435